

Hall Ticket No

--	--	--	--	--	--	--	--	--	--

Question Paper Code: AME001



INSTITUTE OF AERONAUTICAL ENGINEERING
(Autonomous)

B.Tech I Semester End Examinations (Regular) - December, 2016

Regulation: IARE-R16

ENGINEERING DRAWING
(Common for CE/ME)

Time: 3 Hours

Max Marks: 70

Answer ONE Question from each Unit

All Questions Carry Equal Marks

All parts of the question must be answered in one place only

UNIT – I

- (a) Construct a scale of 1:50 to read metres and decimeters and long enough to measure up to 6 m. Mark on it a distance of 5.5 m. [7M]
(b) Construct an ellipse with its foci 40 mm apart and the major axis (distance between the vertices) as 70 mm. Draw a tangent to the curve at a point 20 mm from the focus. [7M]
- A circle of 40 mm diameter rolls on a horizontal line for one complete revolution without slipping. Trace the path of a point on the circumference of circle. Name the curve. [14M]

UNIT – II

- A line PQ 80 mm long is inclined at 30° to VP and 45° to HP. The point P is 10 mm above HP and 20 mm in front of VP. Draw the projection of the line and find the apparent angle of the line with both HP and VP. Also locate the traces. [14M]
- A hexagonal lamina of 30 mm side rests with one of its corners on HP, such that the two edges passing through the corner make equal inclinations with HP. The surface of the lamina is inclined at 30° to HP. The diagonal passing through the corner on which the lamina rests, appears to be inclined at 45° to VP. Draw the front and top views of the lamina in its final position. Also determine the true inclination of the diagonal with VP. [14M]

UNIT – III

- A triangular pyramid of 30 mm base side and axis 50 mm long rests with one of its base edges on HP. Its axis is inclined at 30° to HP and top view of the axis appears to be inclined at 45° to VP. Draw the projections of the pyramid and determine the true inclination of the axis with VP. [14M]
- A right cylinder of 30 mm base diameter and height 70 mm is resting on a point in the base circumference, on HP, such that the axis of the cylinder is inclined at 60° to HP and the top view of the axis appears to be inclined at 45° to VP. Draw the projection of the cylinder and determine the true inclination of the axis with VP. [14M]

UNIT – IV

7. A pentagonal prism of 30 mm base side and height 65 mm is resting on its base on HP, such that one of its base edges is parallel and near to VP. A section plane passes through a point on the axis 30 mm above the HP and is inclined at 45° to HP. Draw the development of the lateral surface of the truncated prism. [14M]
8. Draw the isometric projection of the block shown in Figure 1 [14M]

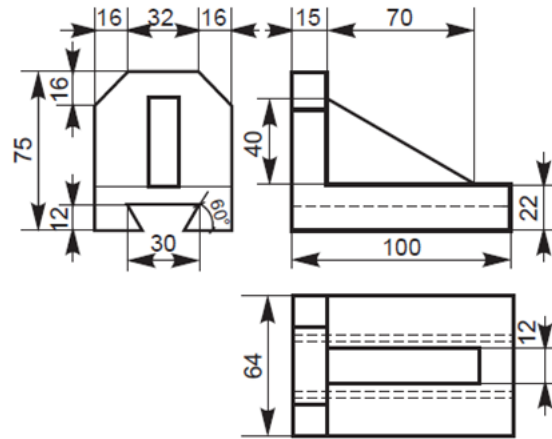

Figure 1

UNIT – V

9. Draw the front view, top view and left side view of the block shown in Figure 2 [14M]

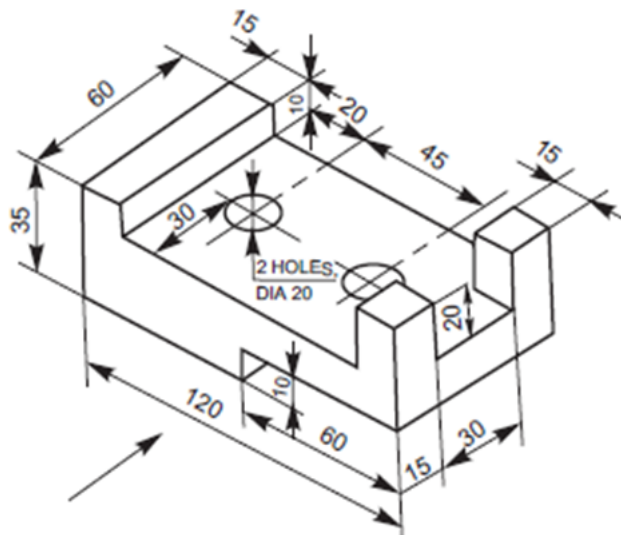

Figure 2

10. Draw the plan, elevation and side view viewed from left side of the block shown in Figure 3 [14M]

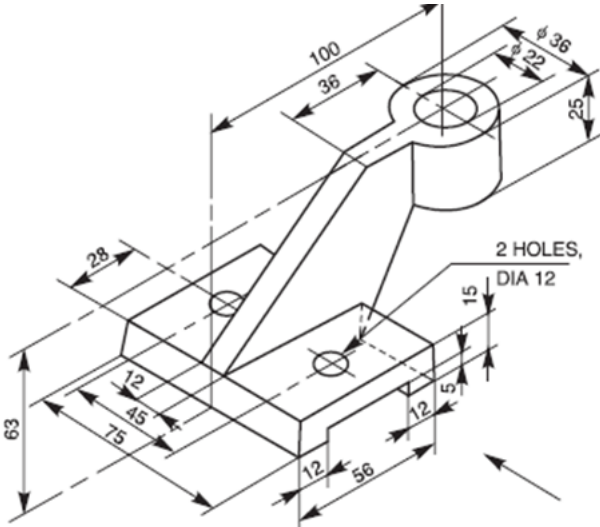

Figure 3