



INSTITUTE OF AERONAUTICAL ENGINEERING
(Autonomous)
Dundigal, Hyderabad -500 043
AERONAUTICAL ENGINEERING

COURSE LECTURE NOTES

Course Name	FLUID MECHANICS AND MACHINES
Course Code	AMEB08
Programme	B.Tech
Semester	IV
Course Coordinator	Dr. CH V K N S N Moorthy, Professor
Course Faculty	Dr. CH V K N S N Moorthy, Professor Mr. G. Sarath Raju, Assistant Professor
Lecture Numbers	1-67
Topic Covered	All

COURSE OBJECTIVES (COs):

The course should enable the students to:	
I	Learn about the application of mass and momentum conservation laws for fluid flows.
II	Understand the importance of dimensional analysis.
III	Obtain the velocity and pressure variations in various types of simple flows.
IV	Analyze the flow in water pumps and turbines.

COURSE LEARNING OUTCOMES (CLOs):

Students, who complete the course, will have demonstrated the ability to do the following:

CLO Code	At the end of the course, the student will have the ability to:
AMEB08.01	Define the properties of fluids and its characteristics.
AMEB08.02	Explain the hydrostatic forces on submerged bodies.
AMEB08.03	Define different types of manometers.
AMEB08.04	Apply the law of conservation of mass and derive continuity equation.
AMEB08.05	Demonstrate practical understanding of friction losses in internal flows.
AMEB08.06	Compare the results of analytical models introduced in lecture to the actual behavior of real fluid flows and draw correct and sustainable conclusions.
AMEB08.07	Calculate the performance analysis in turbines can be used in power plants.
AMEB08.08	Calculate the performance analysis in pumps.
AMEB08.09	Draw and analysis of performance characteristic curves of pumps.
AMEB08.10	Draw and analysis of performance characteristic curves of turbines.
AMEB08.11	Draw and analysis of characteristic curves of flow meters.

CLO Code	At the end of the course, the student will have the ability to:
AMEB08.12	Determine the coefficient of impact of different types of vanes.
AMEB08.13	Determine the coefficient of discharge of different types of flow meters.
AMEB08.14	Determine the friction factor of different types of cross section of pipes.
AMEB08.15	Draw the characteristic curves of friction apparatus.
AMEB08.16	Determine the friction factor using moody's chart.
AMEB08.17	Applying the Darcy's Weisbach equation for the measurement of coefficient of friction.
AMEB08.18	Evaluate the performance of hydraulic turbines.
AMEB08.19	Evaluate the performance of hydraulic pumps.
AMEB08.20	Analyze flow in closed pipes, and design and selection of pipes including sizes.
AMEB08.21	Explain the working principle of various types of hydro turbines and know their application range
AMEB08.22	Demonstrate the various types of major and minor losses in pipes and explain flow between parallel plates.

SYLLABUS

MODULE-I	FLUID STATICS	Classes: 09
Definition of fluid, Newton's law of viscosity, Units and dimension -Properties of fluids, mass density, specific volume, specific gravity, viscosity, compressibility and surface tension, Control volume- application of continuity equation and momentum equation, Incompressible flow.		
MODULE-II	FLUID KINEMATICS AND DYNAMICS	Classes: 09
Fluid Kinematics: Kinematics of fluid flow- Eulerian and Lagrangian descriptions, Stream line, path line, streak line and stream tube, classification and description of flows for one and three dimensions. Fluid Dynamics: Euler's equation of motion, Bernoulli equation for flow along a stream line and applications, Measurement of flow.		
MODULE-III	BOUNDARY LAYER CONCEPTS AND CLOSED CONDUIT FLOW	Classes: 09
Concept of boundary layer, Definition, characteristics along thin plate, laminar, transition and turbulent boundary layers, separation of boundary layer, measures of boundary layer thickness. Closed conduit flow: Darcy Weisbach equation, friction factor, Head loss in pipe flow, Exact flow solutions in channels and ducts, Couette and Poiseuille flow, laminar flow through circular conduits and circular annuli.		
MODULE-IV	FLUID MACHINES	Classes: 09
Classification of water turbines, heads and efficiencies, velocity triangles- Axial, radial and mixed flow turbines- Pelton wheel, Francis turbine and Kaplan turbines, working principles draft tube- Specific speed, unit quantities, performance curves for turbines, governing of turbines.		
MODULE-V	DIMENSIONAL ANALYSIS AND PUMPS	Classes: 09
Dimensional Analysis: Need for dimensional analysis methods of dimension analysis, Similitude, types of similitude Dimensionless parameters application of dimensionless parameters, Model analysis. Pumps: Theory of Roto dynamic machines , various efficiencies , velocity components at entry and exit of the rotor, velocity triangles, Centrifugal pumps, working principle, work done by the impeller, performance curves Cavitation in pumps- Reciprocating pump working principle.		

Text Books:

1. Rajput, “ Fluid Mechanics and Hydraulic Machines”, S.Chand & Co, 6th Edition, 1998
2. H Modi, Seth, “Hydraulics, Fluid Mechanics and Hydraulic Machinery”, Rajsons Publications, 20th Edition, 2013.
3. M. White, Fluid Mechanics, 8th Edition, Tata McGraw Hill, 2016.
4. V. Gupta and S. K. Gupta, Fundamentals of Fluid Mechanics, 4th Edition, New Age International 2011.
5. W. L. McCabe, J. C. Smith and P. Harriot, Unit Operations of Chemical Engineering, 7th Edition, McGraw Hill International Edition 2005.
6. O. Wilkes, Fluid Mechanics for Chemical Engineers, Prentice Hall of India, 2005.
7. R. W. Fox, P. J. Pritchard and A. T. McDonald, Introduction to Fluid Mechanics, 7th Edition, Wiley-India 2010.
8. R. Welty, C. E. Wicks, R. E. Wilson, G. Rorrer, Fundamentals of Momentum, Heat and Mass Transfer, 4th Edition, 2007.

Reference Books:

1. D.S. Kumar, “Fluid Mechanics and Fluid Power Engineering”, Kotaria & Sons, 9th Edition 2013.
2. Dr. R K Bansal, “ A Text Book of Fluid Mechanics and Hydraulic Machines”, Laxmi Publications, 9th Edition, 2015.
3. B. R. Munson, D. F. Young, T. H. Okiishi and W. W. Huebsch, Wiley-India, 6th Edition, 2010.
4. R. L. Panton, Incompressible Flow, Wiley-India, 3rd Edition, 2005.
5. R. B. Bird, W. E. Stewart and E. N. Lightfoot, Transport Phenomena, 2nd Edition, Wiley- India 2002.

Web Reference:

1. <https://nptel.ac.in/courses/112105171/>

E-Book:

1. <https://vscht.cz/uchi/ped/hydrroteplo/materialy/introduction.fluid.mech.pdf>

Module-I

FLUID STATICS

Mechanics: Deals with action of forces on bodies at rest or in motion.

State of rest and Motion: They are relative and depend on the frame of reference. If the position with reference to frame of reference is fixed with time, then the body is said to be in a state of rest. Otherwise, it is said to be in a state of motion.

Scalar and vector quantities: Quantities which require only magnitude to represent them are called scalar quantities. Quantities which acquire magnitudes and direction to represent them are called vector quantities.

Eg: Mass, time interval, Distance traveled _ Scalars

Weight, Displacement, Velocity _ Vectors

Velocity and Speed: Rate of displacement is called velocity and Rate and distance travelled is called Speed.

Unit: m/s

Acceleration: Rate of change of velocity is called acceleration. Negative acceleration is called retardation.

Momentum: The capacity of a body to impart motion to other bodies is called momentum.

The momentum of a moving body is measured by the product of mass and velocity the moving body

Momentum = Mass x Velocity

Unit: Kg·m/s

Newton's first law of motion: Every body continues to be in its state of rest or uniform motion unless compelled by an external agency.

Inertia: It is the inherent property the body to retain its state of rest or uniform motion.

Force: It is an external agency which overcomes or tends to overcome the inertia of a body.

Newton's second law of motion: The rate of change of momentum of a body is directly proportional to the magnitudes of the applied force and takes place in the direction of the applied force.

Measurement of force:

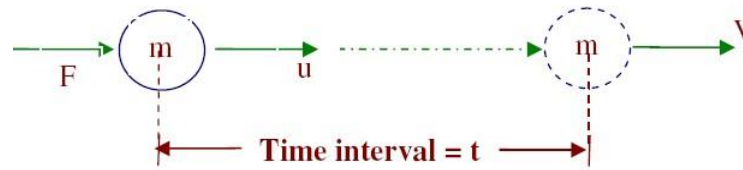

Change in momentum in time 't' = $mv - mu$

$$\text{Rate of change of momentum} = \frac{mv - mu}{t}$$

$$F \propto \frac{mv - mu}{t}$$

$$F \propto m \left(\frac{v - u}{t} \right)$$

$$F \propto ma$$

$$F = K ma$$

If $F = 1$ When $m = 1$ and $u = 1$

Then $K = 1$

$$F = ma.$$

Unit: Newton (N)

Mass: Measure of amount of matter contained by the body it is a scalar quantity. Unit:

Kg.

Weight: Gravitational force on the body. It is a vector quantity.

$$F = ma$$

$$W = mg$$

Unit: Newton (N) $g = 9.81 \text{ m/s}^2$

Volume: Measure of space occupied by the body.

Unit: m³

m³ = 1000 liters

Work: Work done = Force x Displacement _ Linear motion.

Work done = Torque x Angular displacement _ Rotatory motion.

Unit: Nm or J

Energy: Capacity of doing work is called energy.

Unit: Nm or J

Potential energy = mgh

Kinetic energy = $\frac{1}{2} mv^2$

Power: Rate of doing work is called Power.

$$\text{Power:} = \frac{\text{Force x displacement}}{\text{time}}$$

$$= \text{Force x Velocity} \rightarrow \text{Linear Motion.}$$

$$P = \frac{2\pi NT}{60} \rightarrow \text{Rotatory Motion.}$$

Matter: Anything which possesses mass and requires space to occupy is called matter.

States of matter:

Matter can exist in the following states

Solid state.

Solid state: In case of solids intermolecular force is very large and hence molecules

are not free to move. Solids exhibit definite shape and volume. Solids undergo certain amount of deformation and then attain state of equilibrium when subjected to tensile, compressive and shear

Fluid State: Liquids and gases together are called fluids. In case of liquids

Intermolecular force is comparatively small. Therefore liquids exhibit definite volume. But they assume the shape of the container

Liquids offer very little resistance against tensile force. Liquids offer maximum resistance against compressive forces. Therefore, liquids are also called incompressible fluids. Liquids undergo continuous or prolonged angular deformation or shear strain when subjected to tangential force or shear force. This property of the liquid is called flow of liquid. Any substance which exhibits the property of flow is called fluid. Therefore liquids are considered as fluids.

In case of gases intermolecular force is very small. Therefore the molecules are free to move along any direction. Therefore gases will occupy or assume the shape as well as the volume of the container.

Gases offer little resistance against compressive forces. Therefore gases are called compressible fluids. When subjected to shear force gases undergo continuous or prolonged angular deformation or shear strain. This property of gas is called flow of gases. Any substance which exhibits the property of flow is called fluid. Therefore gases are also considered as fluids.

Branches of Mechanics:

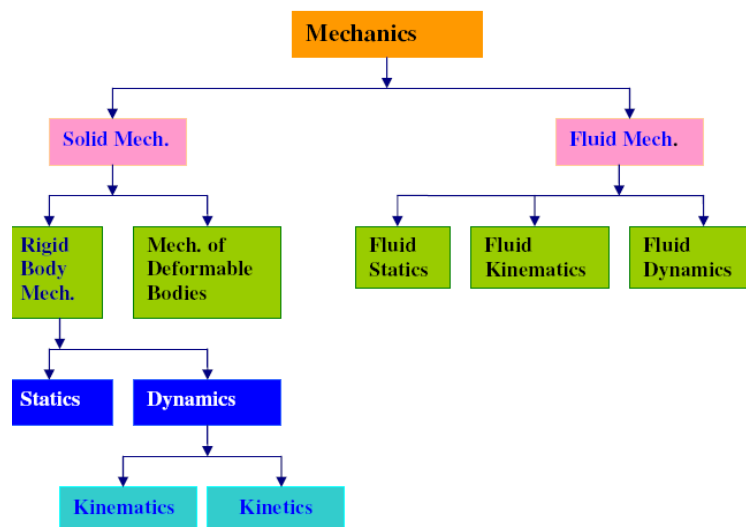

I.Fluid Statics deals with action of forces on fluids at rest or in equilibrium.

II.Fluid Kinematics deals with geometry of motion of fluids without considering the cause of motion

Properties of fluids:

1. Mass density or Specific mass (ρ):

Mass density or specific mass is the mass per unit volume of the fluid.

$$\rho = \frac{\text{Mass}}{\text{Volume}}$$

$$\rho = \frac{M}{V} \text{ or } \frac{dM}{dV}$$

2. Weight density or Specific weight (Υ):

Weight density or Specific weight of a fluid is the weight per unit volume.

Unit: kg/m³ or kgm³

With the increase in temperature volume of fluid increases and hence mass density decreases.

In case of fluids as the pressure increases volume decreases and hence mass density increase

3. Specific gravity or Relative density (S):

It is the ratio of specific weight of the fluid to the specific weight of a standard fluid.

$$S = \frac{\gamma \text{ of fluid}}{\gamma \text{ of standard fluid}}$$

Unit: It is a dimensionless quantity and has no unit.

In case of liquids water at 4°C is considered as standard liquid.

γ (specific weight) of water at 4°C (standard liquid) is $9.81 \frac{kN}{m^3}$ or $9.81 \times 10^3 \frac{kN}{m^3}$

Note: We have

$$1. S = \frac{\gamma}{\gamma_{\text{standard}}}$$
$$\therefore \gamma = S \times \gamma_{\text{standard}}$$

$$2. S = \frac{\gamma}{\gamma_{\text{standard}}}$$
$$S = \frac{\rho \times g}{\rho_{\text{standard}} \times g}$$
$$S = \frac{\rho}{\rho_{\text{standard}}}$$

Specific gravity or relative density of a fluid can also be defined as the ratio of mass density of the fluid to mass density of the standard fluid. Mass density of standard water is 1000 kg/m³.

4. Specific volume (∇): It is the volume per unit mass of the fluid.

$$\therefore \nabla = \frac{\text{Volume}}{\text{mass}}$$
$$\nabla = \frac{V}{M} \text{ or } \frac{dV}{dM}$$

Unit: m³/kg

As the temperature increases volume increases and hence specific volume increases. As the pressure increases volume decreases and hence specific volume decreases.

Effect of temperature on surface tension of liquids:

In case of liquids, surface tension decreases with increase in temperature. Pressure has no or very little effect on surface tension of liquids.

Problems:

1. What is the pressure inside the droplet of water 0.05 mm in diameter at 20°C if the pressure outside the droplet is 103 kPa Take $\sigma = 0.0736 \text{ N/m}$ at 20°C.

$$p = \frac{4\sigma}{D}$$

$$= \frac{4 \times 0.0736}{0.05 \times 10^{-3}}$$

$$p = 5.888 \times 10^3 \text{ N/m}^2$$

$$p = p_{\text{inside}} - p_{\text{outside}}$$

$$p_{\text{inside}} = (5.888 + 103) \times 10^3$$

$$p_{\text{inside}} = 108.88 \times 10^3 \text{ Pa}$$

$$p_{\text{inside}} = ?$$

$$D = 0.05 \times 10^{-3} \text{ m}$$

$$p_{\text{outside}} = 103 \text{ kPa}$$

$$= 103 \times 10^3 \text{ N/m}^2$$

$$\sigma = 0.0736 \text{ N/m}$$

2. liquid bubble 2cm in radius has an internal pressure of 13Pa. Calculate the surface tension of liquid film.

$$p = \frac{8\sigma}{D}$$

$$\sigma = \frac{13 \times 4 \times 10^{-2}}{8}$$

$$\sigma = 0.065 \text{ N/m}$$

$$R = 2 \text{ cm}$$

$$D = 4 \text{ cm}$$

$$= 4 \times 10^{-2} \text{ m}$$

$$p = 13 \text{ Pa (N/m}^2)$$

Compressibility:

It is the property by virtue of which there will be change in volume of fluid due to change in pressure.

Rheological classification of fluids: (Rheology _ Study of stress – strain behavior).

1. **Newtonian fluids:** A fluid which obeys Newton's law of viscosity i.e., $\tau = \mu \cdot \frac{du}{dy}$ is called Newtonian fluid. In such fluids shear stress varies directly as shear strain.

In this case the stress strain curve is a stress line passing through origin the slope of the line gives dynamic viscosity of the fluid.

Eg: Water, Kerosene.

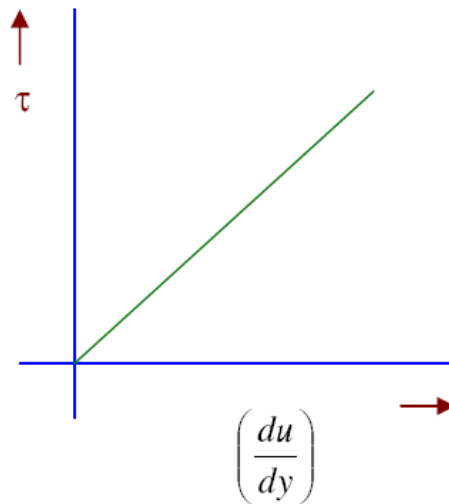

3. **Non-Newtonian fluid:** A fluid which does not obey Newton's law of viscosity is called non-Newton fluid. For such fluids,

$$\tau = \mu \cdot \left(\frac{du}{dy}\right)^n$$

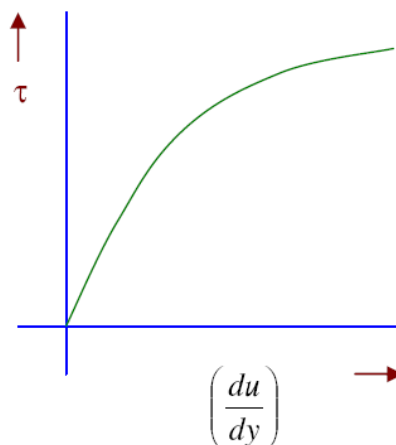

3. Ideal Plastic fluids:

In this case the strain starts after certain initial stress (τ_0) and then the stress strain relationship will be linear. τ_0 is called initial yield stress. Sometimes they are also called Bingham's Plastics.

Eg: Industrial sludge.

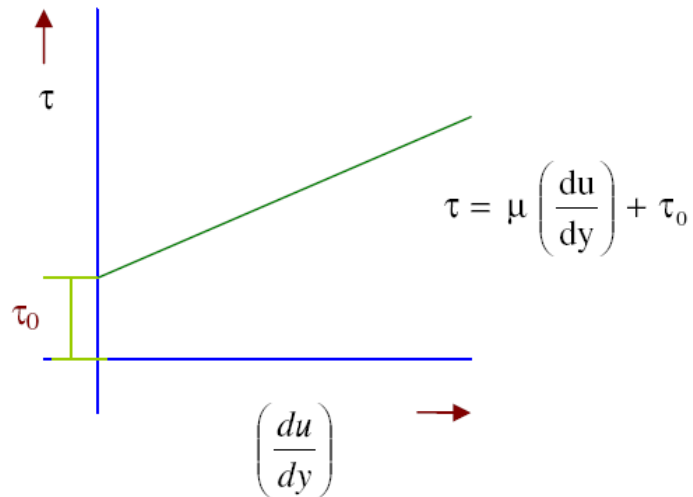

4. Thixotropic fluids:

These require certain amount of yield stress to initiate shear strain. After wards stress-strain relationship will be non – linear.

Eg; Printers ink.

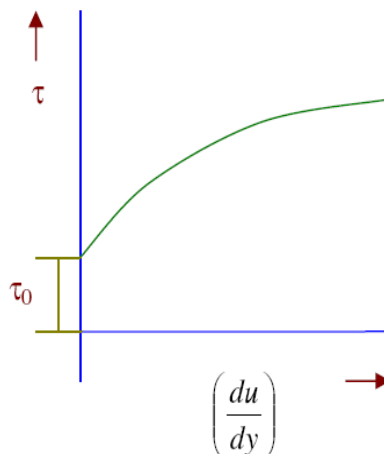

Ideal fluid: Any fluid for which viscosity is assumed to be zero is called Ideal fluid. For ideal fluid $\tau = 0$ for all values of $\frac{du}{dy}$

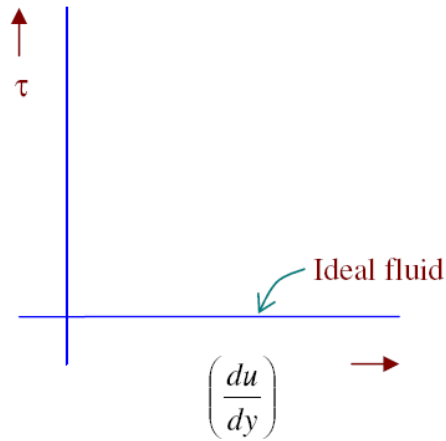

5. Real fluid :

Any fluid which possesses certain viscosity is called real fluid. It can be Newtonian or non-Newtonian, thixotropic or ideal plastic.

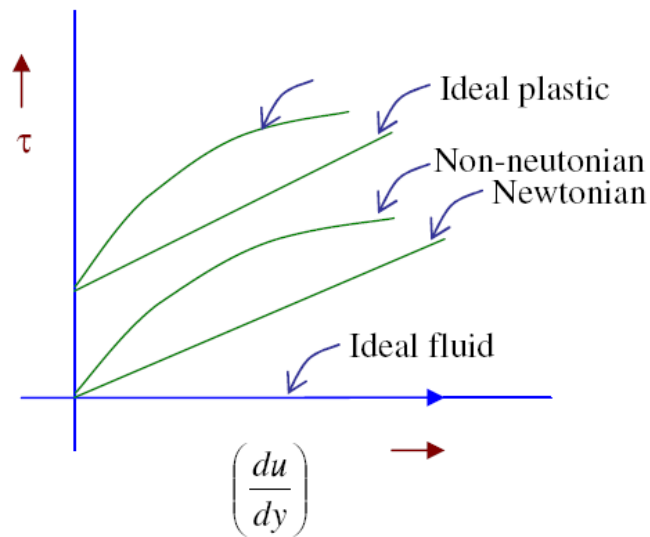

PRESSURE AND ITS MEASUREMENTS:

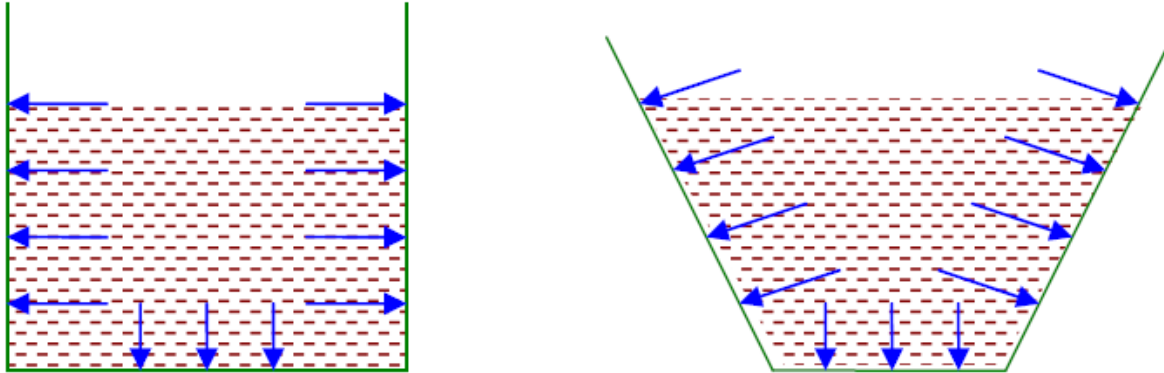

Fluid is a state of matter which exhibits the property of flow. When a certain mass of fluids is held in static equilibrium by confining it within solid boundaries, it exerts force along direction perpendicular to the boundary in contact. This force is called fluid pressure.

• Pressure distribution:

It is the variation of pressure over the boundary in contact with the fluid.

There are two types of pressure distribution.

- a) Uniform Pressure distribution.
- b) Non-Uniform Pressure distribution.

(a) Uniform Pressure distribution:



If the force exerted by the fluid is same at all the points of contact boundary then the pressure distribution is said to be uniform.

(b) Non –Uniform Pressure distribution:

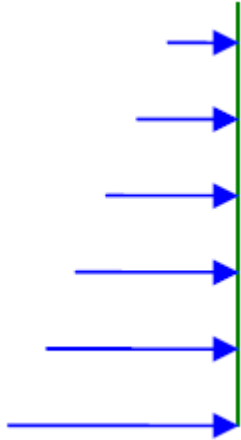

If the force exerted by the fluid is not same at all the points then the pressure distribution is said to be non-uniform.

Intensity of pressure or unit pressure or Pressure:

Intensity of pressure at a point is defined as the force exerted over unit area considered around that point. If the pressure distribution is uniform then intensity of pressure will be same at all the points.

Calculation of Intensity of Pressure:

When the pressure distribution is uniform, intensity of pressure at any points is given by the ratio of total force to the total area of the boundary in contact.

Intensity of Pressure 'p' = F/A

When the pressure distribution is non- uniform, then intensity of pressure at a point is given by dF/dA .

Unit of Intensity of Pressure: N/m^2 or pascal (Pa).

Note: $1\text{ MPa} = 1N/mm^2$

- **Atmospheric pressure**

Air above the surface of liquids exerts pressure on the exposed surface of the liquid and normal to the surface.

This pressure exerted by the atmosphere is called atmospheric pressure.

Atmospheric pressure at a place depends on the elevation of the place and the temperature.

Atmospheric pressure is measured using an instrument called 'Barometer' and hence atmospheric pressure is also called Barometric pressure.

Unit: kPa .

'bar' is also a unit of atmospheric pressure $1\text{bar} = 100\text{ kPa}$.

Absolute pressure and Gauge Pressure:

Absolute pressure at a point is the intensity of pressure at that point measured with reference to absolute vacuum or absolute zero pressure.

Absolute pressure at a point can never be negative since there can be no pressure less than absolute zero pressure.

Absolute pressure at 'A'

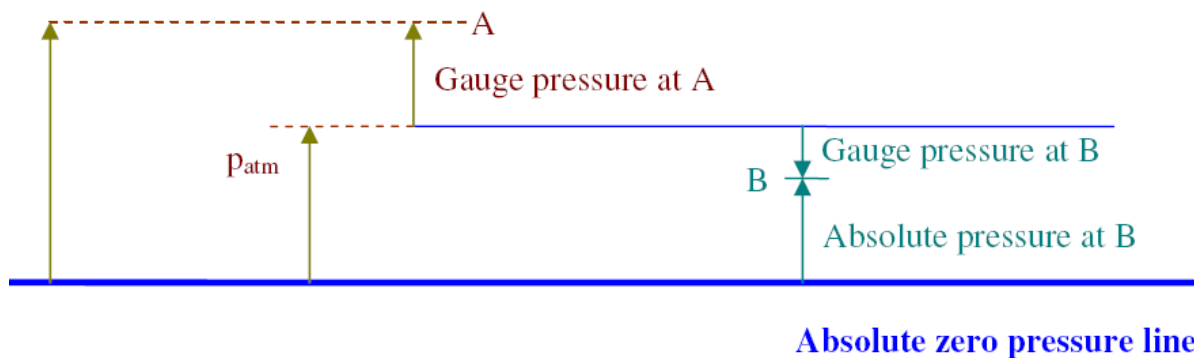

Absolute pressure at a point is the intensity of pressure at that point measured with reference to absolute vacuum or absolute zero pressure.

Absolute pressure at a point can never be negative since there can be no pressure less than absolute zero pressure.

If the intensity of pressure at a point is measured with reference to atmospheric pressure, then it is called gauge pressure at that point.

Gauge pressure at a point may be more than the atmospheric pressure or less than the atmospheric pressure. Accordingly gauge pressure at the point may be positive or negative.

Negative gauge pressure is also called vacuum pressure.

From the figure, It is evident that, Absolute pressure at a point = Atmospheric pressure \pm Gauge pressure.

NOTE: If we measure absolute pressure at a Point below the free surface of the liquid, then,

$$p = \rho \cdot Y + p_{atm}$$

If gauge pressure at a point is required, then atmospheric pressure is taken as zero, then,

$$p = \rho \cdot Y$$

Pressure Head

It is the depth below the free surface of liquid at which the required pressure intensity is available.

$$P = \rho gh$$

$$h = P / \rho g$$

For a given pressure intensity 'h' will be different for different liquids since, 'g' will be different for different liquids. Whenever pressure head is given, liquid or the property of liquid like specify gravity, specific weight, mass density should be given.

Eg:

(i) 3m of water

(ii) 10m of oil of S = 0.8.

(iii) 3m of liquid of $\rho = 15 \text{ kN/m}^3$

(iv) 760mm of Mercury.

(v) 10m _ not correct.

NOTE:

1. To convert head of a liquid to head of another liquid.

$$S = \frac{\gamma}{\gamma_{\text{Standard}}}$$

$$S_1 = \frac{\gamma_1}{\gamma_{\text{Standard}}}$$

$$p = \gamma_1 h_1$$

$$\therefore \gamma_1 = S_1 \gamma_{\text{Standard}}$$

$$p = \gamma_2 h_2$$

$$\gamma_2 = S_2 \gamma_{\text{Standard}}$$

$$\gamma_1 h_1 = \gamma_2 h_2$$

$$\therefore S_1 \gamma_{\text{Standard}} h_1 = S_2 \gamma_{\text{Standard}} h_2$$

$$S_1 h_1 = S_2 h_2$$

2. $S_{\text{water}} \times h_{\text{water}} = S_{\text{liquid}} \times h_{\text{liquid}}$

$1 \times h_{\text{water}} = S_{\text{liquid}} \times h_{\text{liquid}}$

$h_{\text{water}} = S_{\text{liquid}} \times h_{\text{liquid}}$

Pressure head in meters of water is given by the product of pressure head in meters of liquid and specific gravity of the liquid.

Eg: 10meters of oil of specific gravity 0.8 is equal to $10 \times 0.8 = 8$ meters of water.

Eg: Atmospheric pressure is 760mm of Mercury.

NOTE:

$$P = g h$$

kPa kN/m^3 m

Problem:

1. Calculate intensity of pressure due to a column of 0.3m of (a) water (b) Mercury

(c) Oil of specific gravity-0.8.

a) $h = 0.3$ m of water

$$\gamma = 9.81 \frac{\text{kN}}{\text{m}^3}$$

$$p = ?$$

$$p = \gamma h$$

$$p = 2.943 \text{ kPa}$$

c) $h = 0.3$ of Hg

$$\gamma = 13.6 \times 9.81$$

$$\gamma = 133.416 \text{ kN/m}^3$$

$$p = \gamma h$$

$$= 133.416 \times 0.3$$

$$p = 40.025 \text{ kPa}$$

2. Intensity of pressure required at a points is 40kPa. Find corresponding head in

(a) water (b) Mercury (c) oil of specific gravity-0.9.

$$\begin{aligned} \text{(a) } p &= 40 \text{ kPa} & h &= \frac{p}{\gamma} \\ & & h &= 4.077 \text{ m of water} \end{aligned}$$

$$\gamma = 9.81 \frac{\text{kN}}{\text{m}^3}$$

$$h = ?$$

(b) $p = 40 \text{ kPa}$

$$\gamma = (13.6 \times 9.81 \text{ N/m}^3)$$

$$\gamma = 133.416 \frac{\text{KN}}{\text{m}^3}$$

$$h = \frac{p}{\gamma}$$

$$h = 0.299 \text{ m of Mercury}$$

$$h = \frac{p}{\gamma}$$

c) $p = 40 \text{ kPa}$

$$h = 4.53 \text{ m of oil } S = 0.9$$

$$\gamma = 0.9 \times 9.81$$

$$\gamma = 8.829 \frac{\text{KN}}{\text{m}^3}$$

4. Standard atmospheric pressure is 101.3 kPa Find the pressure head in (i) Meters of water (ii) mm of mercury (iii) m of oil of specific gravity 0.8.

(i) $p = \gamma h$

$$101.3 = 9.81 \times h$$

$$h = 10.3 \text{ m of water}$$

(ii) $p = \gamma h$

$$101.3 = (13.6 \times 9.81) \times h$$

$$h = 0.76 \text{ m of mercury}$$

(iii) $p = \gamma h$

$$101.3 = (0.8 \times 9.81) \times h$$

$$h = 12.9 \text{ m of oil of } S = 0.8$$

5. An open container has water to a depth of 2m and above this an oil of $S = 0.9$ for a depth of 1m. Find the intensity of pressure at the interface of two liquids and at the bottom of the tank.

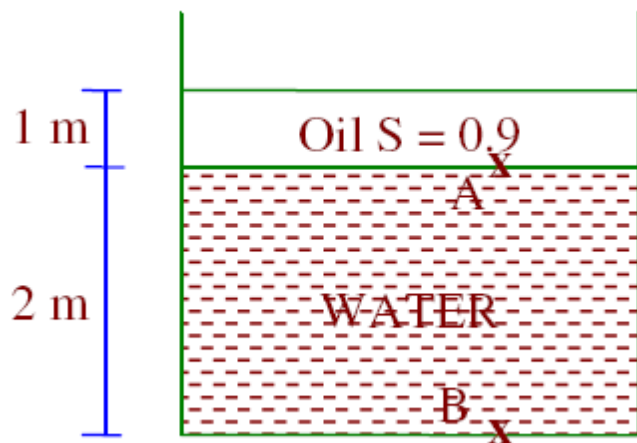

$$p_A = \gamma_{\text{oil}} h_{\text{oil}}$$

$$= (0.9 \times 9.81) \times 1$$

$$p_A = 8.829 \text{ kPa}$$

$$p_B = \gamma_{\text{oil}} x h_{\text{oil}} + \gamma_{\text{water}} + h_{\text{water}}$$

$$p_A = 8.829 \text{ kPa} + 9.81 \times 2$$

$$p_B = 28.45 \text{ kPa}$$

6. Convert the following absolute pressure to gauge pressure (a) 120kPa (b) 3kPa (c) 15m of H₂O (d) 800mm of Hg.

$$(a) p_{\text{abs}} = p_{\text{atm}} + p_{\text{gauge}}$$

$$\therefore p_{\text{gauge}} = p_{\text{abs}} - p_{\text{atm}} = 120 - 101.3 = 18.7 \text{ kPa}$$

$$(b) p_{\text{gauge}} = 3 - 101.3 = -98.3 \text{ kPa}$$

$$p_{\text{gauge}} = 98.3 \text{ kPa (vacuum)}$$

$$(c) h_{\text{abs}} = h_{\text{atm}} + h_{\text{gauge}}$$

$$15 = 10.3 + h_{\text{gauge}}$$

$$h_{\text{gauge}} = 4.7 \text{ m of water}$$

$$(d) h_{\text{abs}} = h_{\text{atm}} + h_{\text{gauge}}$$

$$800 = 760 + h_{\text{gauge}}$$

$$h_{\text{gauge}} = 40 \text{ mm of mercury}$$

Measurement of Pressure

Various devices used to measure fluid pressure can be classified into,

1. Manometers
2. Mechanical gauges.

Manometers are the pressure measuring devices which are based on the principal of balancing the column of the liquids whose pressure is to be measured by the same liquid or another liquid.

Mechanical gauges consist of an elastic element which deflects under the action of applied pressure and this movement will operate a pointer on a graduated scale.

Classification of Manometers:

Manometers are broadly classified into

- a) Simple Manometers
- b) Differential Manometers.

a) Simple Manometers

Simple monometers are used to measure intensity of pressure at a point.

They are connected to the point at which the intensity of pressure is required. Such a point is called gauge point.

b) Differential Manometers

Differential manometers are used to measure the pressure difference between two points. They are connected to the two points between which the intensity of pressure is required.

Types of Simple Manometers

Common types of simple manometers are

- a) Piezometers
- b) U-tube manometers
- c) Single tube manometers
- d) Inclined tube manometers

a) Piezometers:

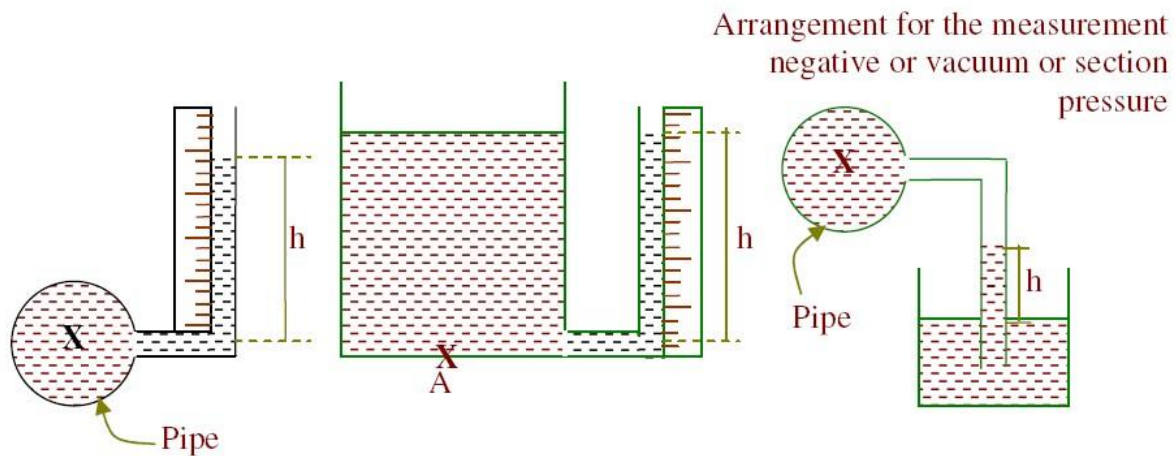

Piezometer consists of a glass tube inserted in the wall of the vessel or pipe at the level of point at which the intensity of pressure is to be measured. The other end of the piezometer is exposed to air. The height of the liquid in the piezometer gives the pressure head from which the intensity of pressure can be calculated.

To minimize capillary rise effects the diameters of the tube is kept more than 12mm.

Merits

- _ Simple in construction
- _ Economical

Demerits

- _ Not suitable for high pressure intensity.
- _ Pressure of gases cannot be measured.

(b) U-tube Manometers:

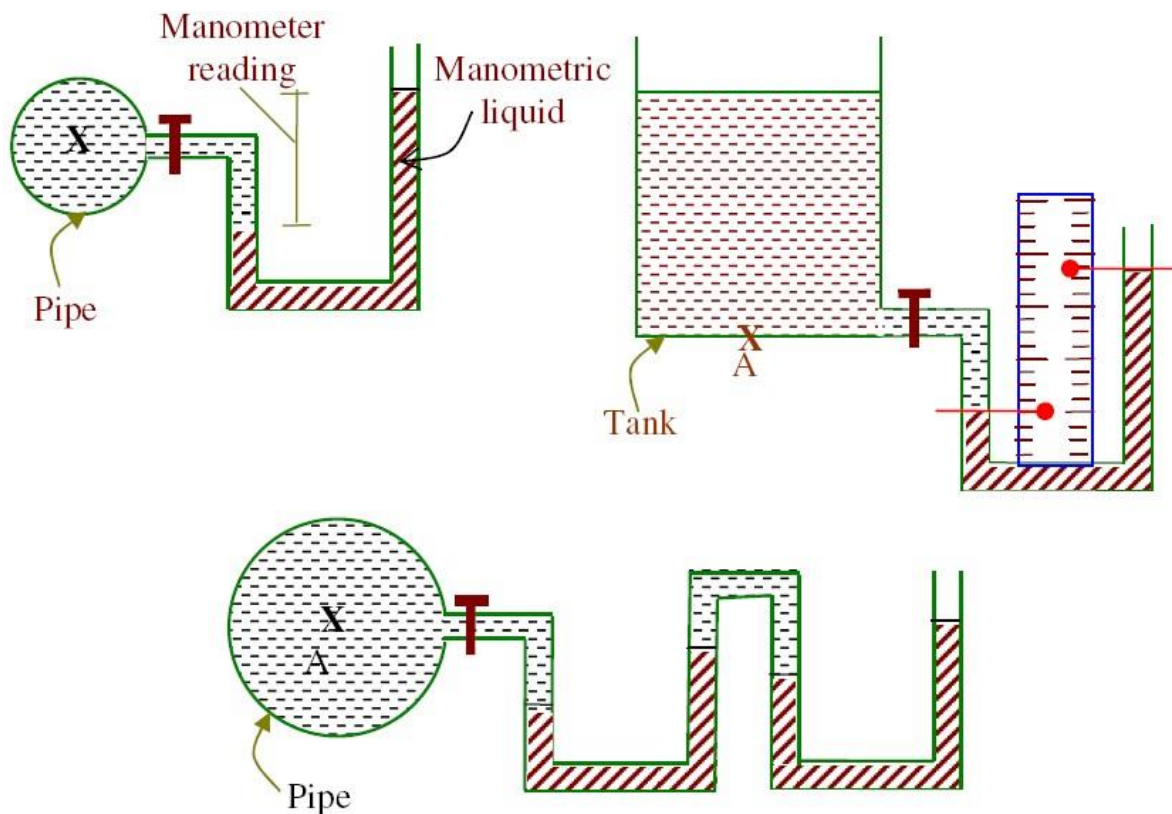

A U-tube manometers consists of a glass tube bent in U-Shape, one end of which is connected to gauge point and the other end is exposed to atmosphere. U-tube consists of a liquid of specific of gravity other than that of fluid whose pressure intensity is to be measured and is called manometric liquid.

- **Manometric liquids**

- “ Manometric liquids should neither mix nor have any chemical reaction with the fluid whose pressure intensity is to be measured.

- “ It should not undergo any thermal variation.

- “ Manometric liquid should have very low vapour pressure.

- “ Manometric liquid should have pressure sensitivity depending upon the magnitude of pressure to be measured and accuracy requirement.

- **To write the gauge equation for manometers**

Gauge equations are written for the system to solve for unknown quantities.

Steps:

1. Convert all given pressure to meters of water and assume unknown pressure in meters of waters.

2. Starting from one end move towards the other observing the following points.

“ Any horizontal movement inside the same liquid will not cause change in pressure.

“ Vertically downward movement causes increase in pressure and upward motion causes decrease in pressure.

“ Convert all vertical columns of liquids to meters of water by multiplying them by corresponding specify gravity.

“ Take atmospheric pressure as zero (gauge pressure computation).

3. Solve for the unknown quantity and convert it into the required unit.

4. If required calculate absolute pressure.

Problem:

1. Determine the pressure at A for the U- tube manometer shown in fig. Also calculate the absolute pressure at A in kPa.

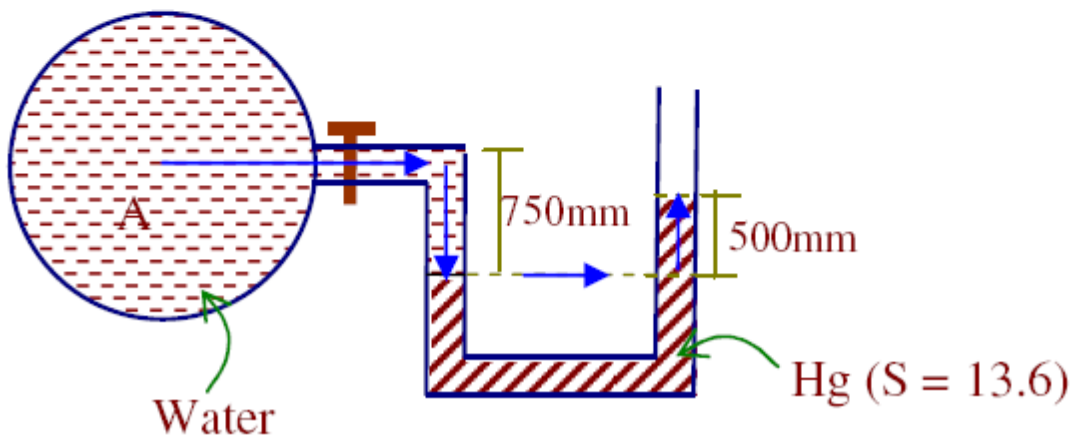
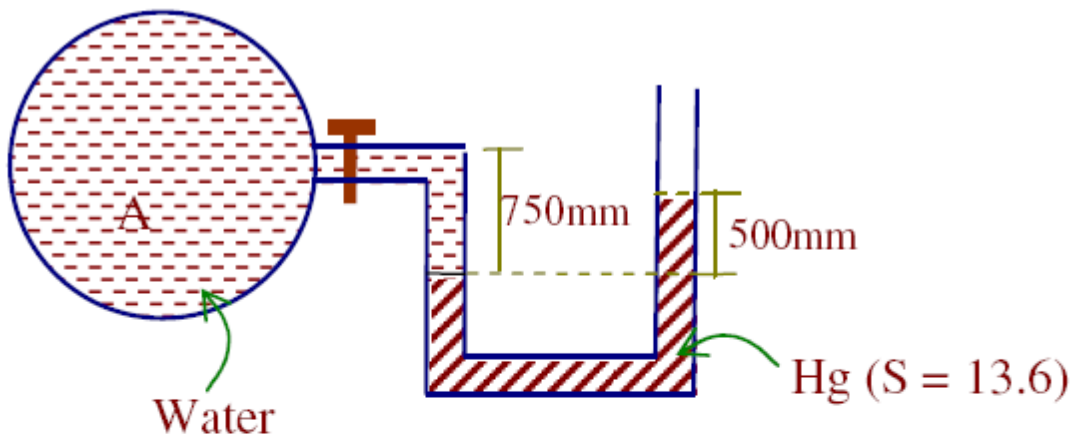

Let 'h_A' be the pressure head at 'A' in 'meters of water'.

$$h_A + 0.75 - 0.5 \times 13.6 = 0$$

$$h_A = 6.05 \text{ m of water}$$

$$p = \gamma h$$

$$= 9.81 \times 6.05$$

$$p = 59.35 \text{ kPa (gauge pressure)}$$

$$p_{abs} = p_{atm} + p_{gauge}$$

$$= 101.3 + 59.35$$

$$p_{abs} = 160.65 \text{ kPa}$$

2. For the arrangement shown in figure, determine gauge and absolute pressure at the point M.

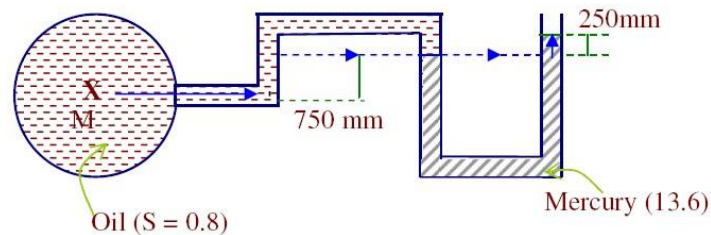

Let 'h_M' be the pressure head at the point 'M' in m of water,

$$h_M - 0.75 \times 0.8 - 0.25 \times 13.6 = 0$$

$$h_M = 4 \text{ m of water}$$

$$p = \gamma h$$

$$p = 39.24 \text{ kPa}$$

$$p_{abs} = 101.3 + 39.24$$

$$p_{abs} = 140.54 \text{ kPa}$$

3. If the pressure at 'At' is 10 kPa (Vacuum) what is the value of 'x'?

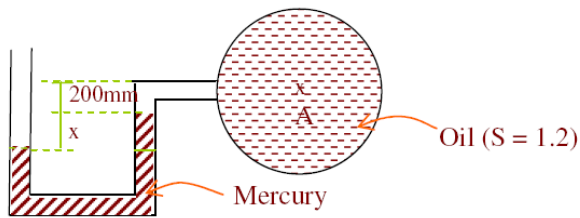

$$p_A = 10 \text{ kPa (Vacuum)}$$

$$p_A = -10 \text{ kPa}$$

$$\frac{p_A}{\gamma} = \frac{-10}{9.81} = -1.019 \text{ m of water}$$

$$h_A = -1.019 \text{ m of water}$$

$$-1.019 + 0.2 \times 1.2 + x(13.6) = 0$$

$$x = 0.0572 \text{ m}$$

4. The tank in the accompanying figure consists of oil of $S = 0.75$. Determine the pressure gauge reading in kN/m^2 .

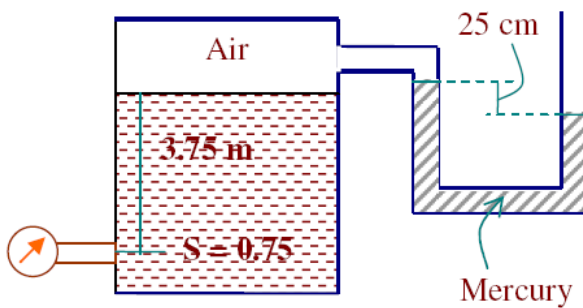

Let the pressure gauge reading be 'h' m of water

$$h - 3.75 \times 0.75 + 0.25 \times 13.6 = 0$$

$$h = -0.5875 \text{ m of water}$$

$$p = \gamma h$$

$$p = -5.763 \text{ kPa}$$

$$p = 5.763 \text{ kPa (Vacuum)}$$

5. A closed tank is 8m high. It is filled with Glycerine up to a depth of 3.5m and linseed oil to another 2.5m. The remaining space is filled with air under a pressure of 150 kPa. If a pressure gauge is fixed at the bottom of the tank what will be its reading.

Also calculate absolute pressure. Take relative density of Glycerine and Linseed oil as 1.25 and 0.93 respectively.

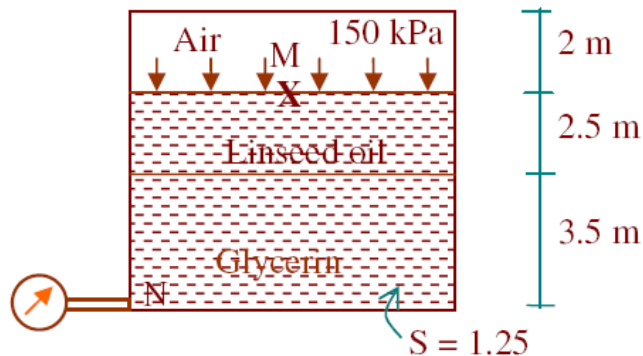

$$P_H = 150 \text{ kPa}$$

$$h_M = \frac{150}{9.81}$$

$$h_M = 15.29 \text{ m of water}$$

Let 'h_N' be the pressure gauge reading in m of water.

$$h_N - 3.5 \times 1.25 - 2.5 \times 0.93 = 15.29$$

$$h_N = 21.99 \text{ m of water}$$

$$p = 9.81 \times 21.99$$

$$p = 215.72 \text{ kPa (gauge)}$$

$$p_{\text{abs}} = 317.02 \text{ kPa}$$

DIFFERENTIAL MANOMETERS

Differential manometers are used to measure pressure difference between any two points. Common varieties of differential manometers are:

- (a) Two piezometers.
- (b) Inverted U-tube manometer.
- (c) U-tube differential manometers.
- (d) Micromanometers.

(a) Two Pizometers

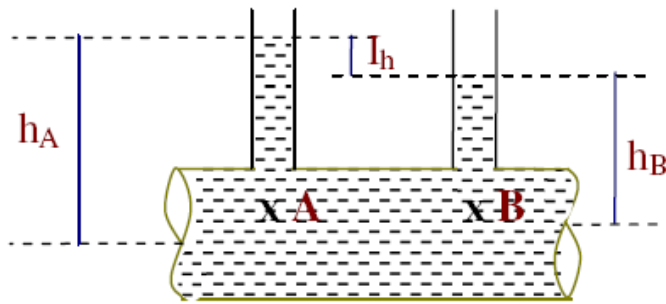

The arrangement consists of two piezometers at the two points between which the pressure difference is required. The liquid will rise in both the piezometers. The difference in elevation of liquid levels can be recorded and the pressure difference can be calculated.

It has all the merits and demerits of piezometer.

(b) Inverted U-tube manometers

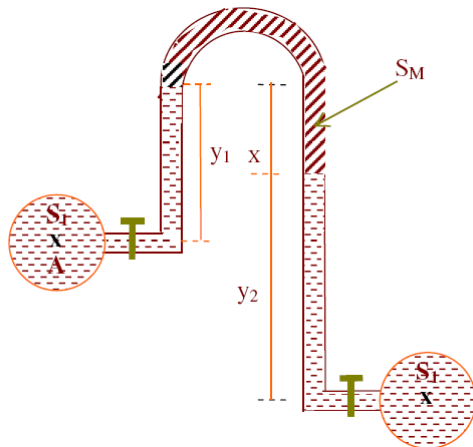

Inverted U-tube manometer is used to measure small difference in pressure between any two points. It consists of an inverted U-tube connecting the two points between which the pressure difference is required. In between there will be a lighter manometric liquid. Pressure difference between the two points can be calculated by writing the gauge equations for the system.

Let 'hA' and 'hB' be the pressure head at 'A' and 'B' in meters of water

$$h_A - (y_1 S_1) + (x S_M) + (y_2 S_2) = h_B$$

$$h_A - h_B = S_1 y_1 - S_M x - S_2 y_2,$$

$$p_A - p_B = \rho g (h_A - h_B)$$

(c) U-tube Differential manometers

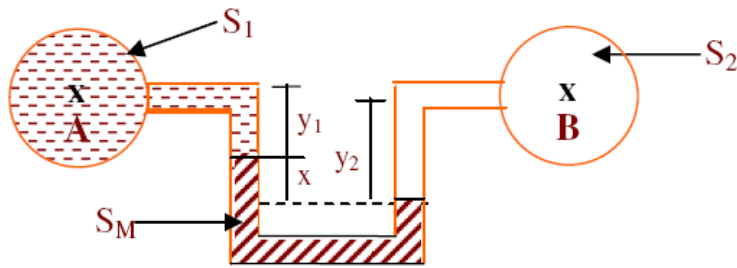

A differential U-tube manometer is used to measure pressure difference between any two points. It consists of a U-tube containing heavier manometric liquid, the two limbs of which are connected to the gauge points between which the pressure difference is required. U-tube differential manometers can also be used for gases. By writing the gauge equation for the system pressure difference can be determined.

Let 'hA' and 'hB' be the pressure head of 'A' and 'B' in meters of water

$$h_A + S_1 Y_1 + x S_M - Y_2 S_2 = h_B$$

$$h_A - h_B = Y_2 S_2 - Y_1 S_1 - x S_M$$

Problems

(1) An inverted U-tube manometer is shown in figure. Determine the pressure difference between A and B in N/m^2

Let hA and hB be the pressure heads at A and B in meters of water.

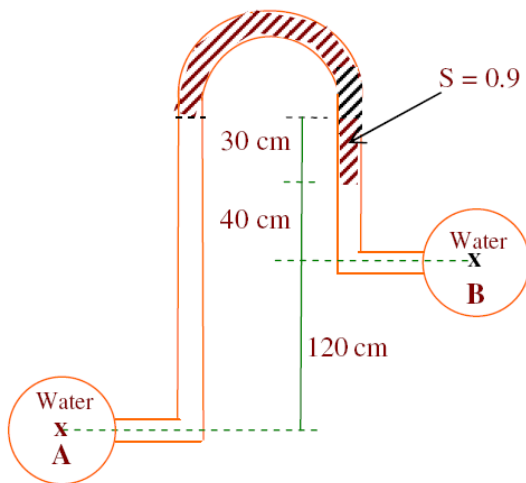

$$h_A - (190 \times 10^{-2}) + (0.3 \times 0.9) + (0.4) 0.9 = h_B$$

$$h_A - h_B = 1.23 \text{ meters of water}$$

$$p_A - p_B = \gamma (h_A - h_B) = 9.81 \times 1.23$$

$$p_A - p_B = 12.06 \text{ kPa}$$

$$p_A - p_B = 12.06 \times 10^3 \text{ N/m}^2$$

2. In the arrangements shown in figure. Determine the ho 'h'.

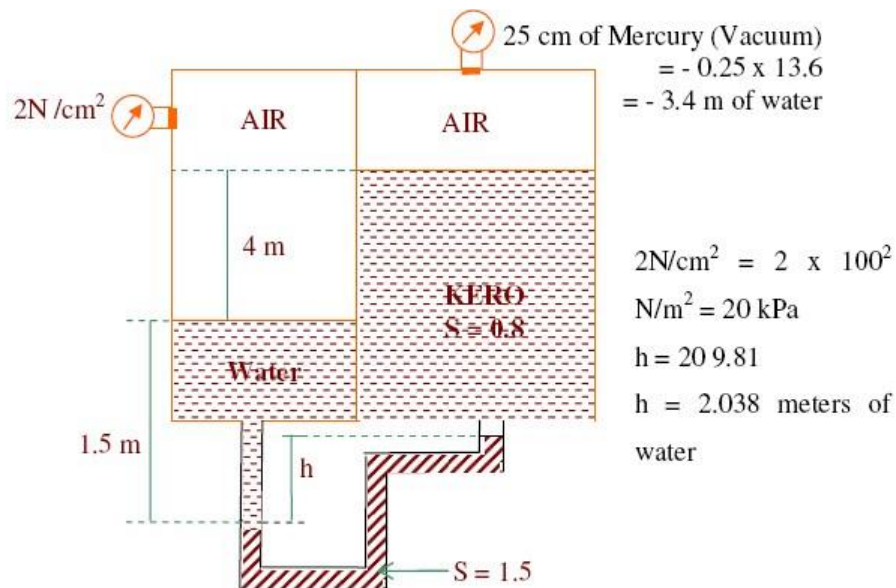

$$2.038 + 1.5 - (4 + 1.5 - h) 0.8 = -3.4$$

$$h = 3.6 \text{ m}$$

3. Compute the pressure different between 'M' and 'N' for the system shown in figure.

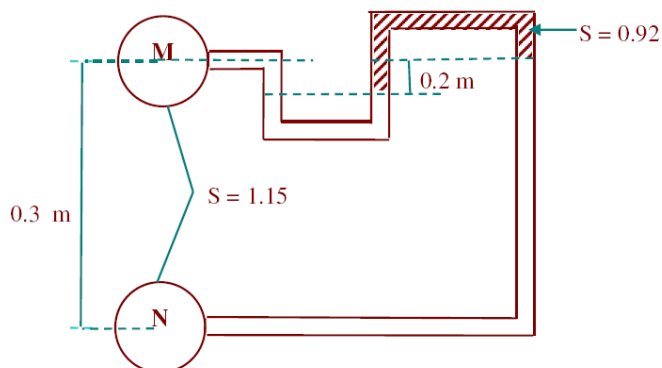

Let 'h_M' and 'h_N' be the pressure heads at M and N in m of water.

$$h_m + y \times 1.15 - 0.2 \times 0.92 + (0.3 - y + 0.2) \times 1.15 = h_n$$

$$h_m + 1.15y - 0.184 + 0.3 \times 1.15 - 1.15y + 0.2 \times 1.15 = h_n$$

$$h_m + 0.391 = h_n$$

$$h_n - h_m = 0.391 \text{ meters of water}$$

$$p_n - p_m = \gamma (h_n - h_m)$$

$$= 9.81 \times 0.391$$

$$p_n - p_m = 3.835 \text{ kPa}$$

4. Petrol of specific gravity 0.8 flows up through a vertical pipe. A and B are the two points in the pipe, B being 0.3 m higher than A. Connection are led from A and B to a U-tube containing Mercury. If the pressure difference between A and B is 18 kPa, find the reading of manometer.

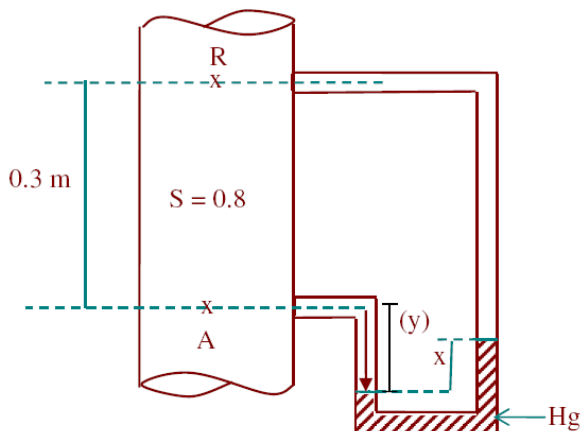

$$p_A - p_B = 18 \text{ kPa}$$

$$\frac{P_A - P_B}{\gamma}$$

$$h_A - h_B = \frac{18}{9.81}$$

$$h_A - h_B = 1.835 \text{ m of water}$$

$$h_A + y \times 0.8 - x \times 13.6 - (0.3 + y - x) \times 0.8 = h_B$$

$$h_A - h_B = -0.8y + 13.6x + 0.24 + 0.8y - 0.8x$$

$$h_A - h_B = 12.8x + 0.24$$

$$1.835 = 12.8x + 0.24$$

$$x = 0.1246 \text{ m}$$

4. What is the pressure p_A in the fig given below? Take specific gravity of oil as 0.8.

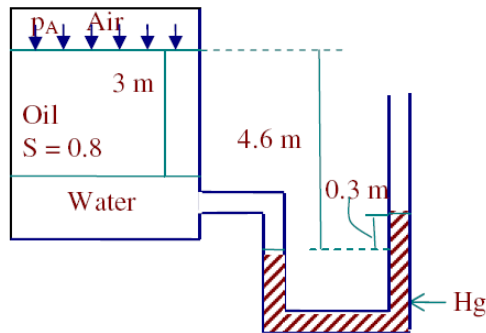

$$h_A + (3 \times 0.8) + (4.6 - 0.3) (13.6) = 0$$

$$h_A = 2.24 \text{ m of oil}$$

$$p_A = 9.81 \times 2.24$$

$$p_A = 21.97 \text{ kPa}$$

SINGLE COLUMN MANOMETER:

Single column manometer is used to measure small pressure intensities.

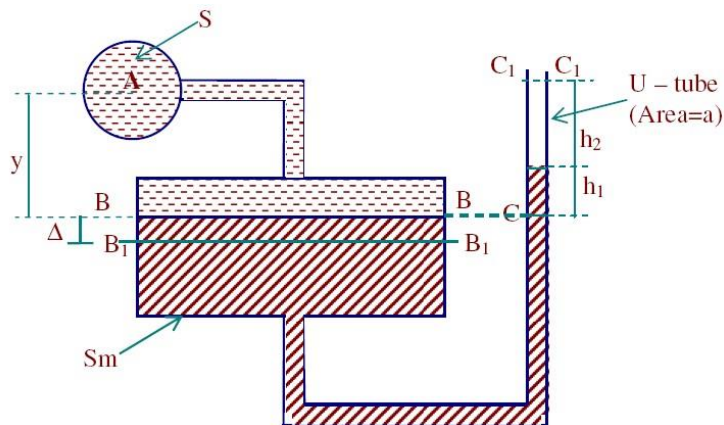

A single column manometer consists of a shallow reservoir having large cross sectional area when compared to cross sectional area of U – tube connected to it. For any change in pressure, change in the level of manometric liquid in the reservoir is small and change in level of manometric liquid in the U- tube is large.

To derive expression for pressure head at A:

BB and CC are the levels of manometric liquid in the reservoir and U-tube before connecting the point A to the manometer, writing gauge equation for the system we have,

$$+ y \times S - h_1 \times S_m = 0$$

$$S y = S_m h_1$$

Let the point A be connected to the manometer. B1B1 and C1 C1 are the levels of manometric liquid. Volume of liquid between B1B1 = Volume of liquid between

Let the point A be connected to the manometer. B1B1 and C1 C1 are the levels of manometric liquid. Volume of liquid between B1B1 = Volume of liquid between

C1C1

$$A \Delta = a h_2$$

$$\Delta = \frac{a h_2}{A}$$

Let 'h_A' be the pressure head at A in m of water.

$$h_A + (y + \Delta) S - (\Delta + h_1 + h_2) S_m = 0$$

$$h_A = (\Delta + h_1 + h_2) S_m - (y + \Delta) S$$

$$= \Delta S_m + h_1 S_m + h_2 S_m - y S - \Delta S$$

$$h_A = \Delta (S_m - S) + h_2 S_m$$

$$h_A = \frac{a h_2}{A} (S_m - S) + h_2 S_m$$

∴ It is enough if we take one reading to get 'h₂' If 'a/A' is made very small (by increasing

'A') then the 1 term on the RHS will be negligible.

$$\text{Then } h_A = h_2 S_m$$

MECHANICAL GAUGES:

Pressure gauges are the devices used to measure pressure at a point.

They are used to measure high intensity pressures where accuracy requirement is less.

Pressure gauges are separate for positive pressure measurement and negative pressure measurement. Negative pressure gauges are called Vacuum gauges.

BASIC PRINCIPLE:

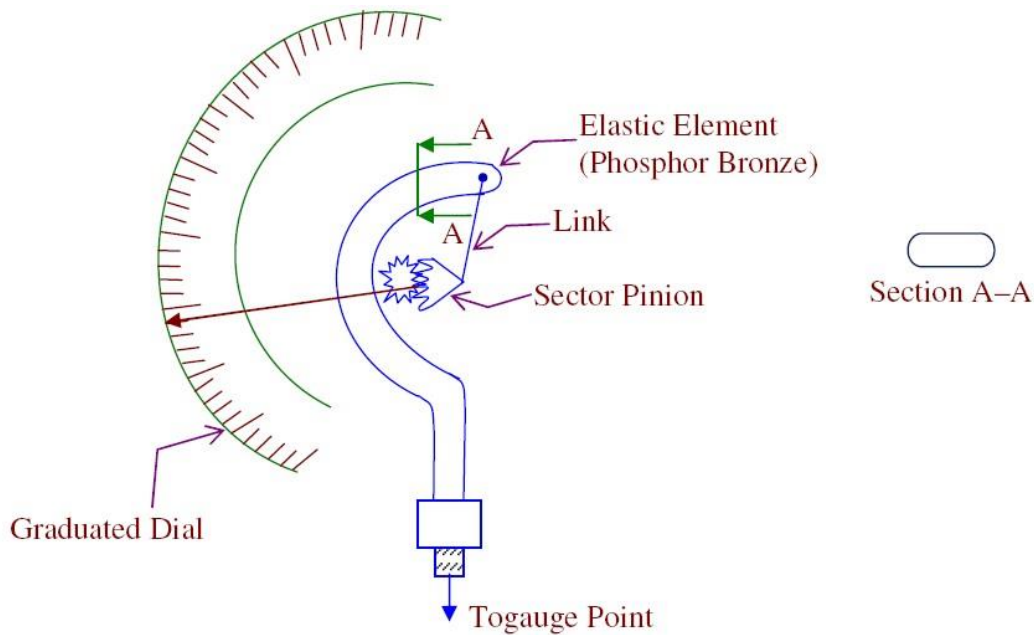

Mechanical gauge consists of an elastic element which deflects under the action of applied pressure and this deflection will move a pointer on a graduated dial leading to the measurement of pressure. Most popular pressure gauge used is Bordon pressure gauge.

The arrangement consists of a pressure responsive element made up of phosphor bronze or special steel having elliptical cross section. The element is curved into a circular arc, one end of the tube is closed and free to move and the other end is connected to gauge point. The changes in pressure cause change in section leading to the movement. The movement is transferred to a needle using sector pinion mechanism. The needle moves over a graduated dial.

Module-II

FLUID KINEMATICS AND DYNAMICS

FLUID KINEMATICS

Fluid Kinematics gives the geometry of fluid motion. It is a branch of fluid mechanics, which describes the fluid motion, and its consequences without consideration of the nature of forces causing the motion. Fluid kinematics is the study of velocity as a function of space and time in the flow field. From velocity, pressure variations and hence, forces acting on the fluid can be determined.

VELOCITY FIELD

Velocity at a given point is defined as the instantaneous velocity of the fluid particle, which at a given instant is passing through the point. It is represented by $V=V(x,y,z,t)$. Vectorially, $V=ui+vj+wk$ where u,v,w are three scalar components of velocity in x,y and z directions and (t) is the time. Velocity is a vector quantity and velocity field is a vector field.

Fluid Mechanics is a visual subject. Patterns of flow can be visualized in several ways. Basic types of line patterns used to visualize flow are streamline, path line, streak line and time line.

- (a) Stream line is a line, which is everywhere tangent to the velocity vector at a given instant.
- (b) Path line is the actual path traversed by a given particle.
- (c) Streak line is the locus of particles that have earlier passed through a prescribed point.
- (d) Time line is a set of fluid particles that form a line at a given instant.

Streamline is convenient to calculate mathematically. Other three lines are easier to obtain experimentally. Streamlines are difficult to generate experimentally. Streamlines and Time lines are instantaneous lines. Path lines and streak lines are generated by passage of time. In a steady flow situation, streamlines, path lines and streak lines are identical. In Fluid Mechanics, the most common mathematical result for flow visualization is the streamline pattern – It is a common method of flow pattern presentation.

Streamlines are everywhere tangent to the local velocity vector. For a stream line, $(dx/u) = (dy/v) = (dz/w)$. Stream tube is formed by a closed collection of streamlines. Fluid within the stream tube is confined there because flow cannot cross streamlines. Stream tube walls need not be solid, but may be fluid surfaces

METHOD OF DESCRIBING FLUID MOTION

Two methods of describing the fluid motion are: (a) Lagrangian method and (b) Eulerian method. A single fluid particle is followed during its motion and its velocity, acceleration etc. are described with respect to time. Fluid motion is described by tracing the kinematics behavior of each and every individual particle constituting the flow. We follow individual fluid particle as it moves through the flow. The particle is identified by its position at some instant and the time elapsed since that instant. We identify and follow small, fixed masses of fluid. To describe the fluid flow where there is a relative motion, we need to follow many particles and to resolve details of the flow; we need a large number of particles. Therefore, Lagrangian method is very difficult and not widely used in Fluid Mechanics.

EULARIAN METHOD

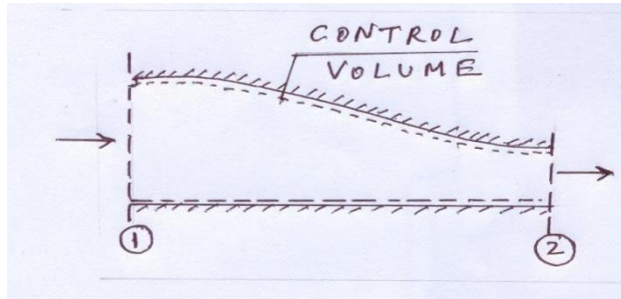

Fig. Eulerian Method

The velocity, acceleration, pressure etc. are described at a point or at a section as a function of time. This method commonly used in Fluid Mechanics. We look for field description, for Ex.; seek the velocity and its variation with time at each and every location in a flow field. Ex., $V=V(x,y,z,t)$. This is also called control volume approach. We draw an imaginary box around a fluid system. The box can be large or small, and it can be stationary or in motion.

TYPES OF FLUID FLOW

1. Steady and Un-steady flows
2. Uniform and Non-uniform flows
3. Laminar and Turbulent flows
4. Compressible and Incompressible flows
5. Rotational and Irrotational flows
6. One, Two and Three dimensional flows

STEADY AND UNSTEADY FLOW

Steady flow is the type of flow in which the various flow parameters and fluid properties at any point do not change with time. In a steady flow, any property may vary from point to point in the field, but all properties remain constant with time at

every point. [$\frac{\partial V}{\partial t} = 0$; $\frac{\partial p}{\partial t} = 0$] $x,y,z = 0$. Ex.: $V=V(x,y,z)$; $p=p(x,y,z)$. Time is a criterion.

Unsteady flow is the type of flow in which the various flow parameters and

fluid properties at any point change with time. [$\frac{\partial V}{\partial t} \neq 0$; $\frac{\partial p}{\partial t} \neq 0$] $x,y,z \neq 0$.

Eg.: $V=V(x,y,z,t)$, $p=p(x,y,z,t)$ or $V=V(t)$, $p=p(t)$. Time is a criterion

UNIFORM AND NON-UNIFORM FLOWS

Uniform Flow is the type of flow in which velocity and other flow parameters at any instant of time do not change with respect to space. Eg., $V=V(x)$ indicates that the flow is uniform in 'y' and 'z' axis. $V=V(t)$ indicates that the flow is uniform in 'x', 'y' and 'z' directions. Space is a criterion.

Uniform flow field is used to describe a flow in which the magnitude and direction of the velocity vector are constant, i.e., independent of all space coordinates throughout the entire flow field (as opposed to uniform flow at a cross

section). That is, [$\frac{\partial V}{\partial s} = 0$, that is 'V' has unique value in entire flow

$\frac{\partial V}{\partial s}$]

field.

Non-uniform flow is the type of flow in which velocity and other flow parameters at any instant change with respect to space.

[$\frac{\partial V}{\partial s} \neq 0$, that is 'V' has different values in different parts of the flow field at any instant of time. Distance or space is a criterion

constant is not equal to zero. Distance or space is a criterion

LAMINAR AND TURBULANT FLOWS

Laminar Flow is a type of flow in which the fluid particles move along well-defined paths or stream-lines. The fluid particles move in laminas or layers gliding

smoothly over one another. The behavior of fluid particles in motion is a criterion. Turbulent Flow

is a type of flow in which the fluid particles move in zigzag way

in the flow field. Fluid particles move randomly from one layer to another. Reynolds number is a criterion. We can assume that for a flow in pipe, for Reynolds No. less than 2000, the flow is laminar; between 2000-4000, the flow is transitional; and greater than 4000, the flow is turbulent.

COMPRESSIBLE AND INCOMPRESSIBLE FLOWS

Incompressible Flow is a type of flow in which the density (ρ) is constant in the flow field. This assumption is valid for flow Mach numbers with in 0.25. Mach number is used as a criterion. Mach Number is the ratio of flow velocity to velocity of sound waves in the fluid medium

Compressible Flow is the type of flow in which the density of the fluid changes in the flow field. Density is not constant in the flow field. Classification of flow based on Mach number is given below:

$M < 0.25$ – Low speed

$M < \text{unity}$ – Subsonic

M around unity – Transonic

$M > \text{unity}$ – Supersonic

$M \gg \text{unity}$, (say 7) – Hypersonic

ROTATIONAL AND IRROTATIONAL FLOWS

Rotational flow is the type of flow in which the fluid particles while flowing along stream-lines also rotate about their own axis.

Ir-rotational flow is the type of flow in which the fluid particles while flowing along stream-lines do not rotate about their own axis.

ONE, TWO AND THREE DIMENSIONAL FLOWS

The number of space dimensions needed to define the flow field completely governs dimensionality of flow field. Flow is classified as one, two and three- dimensional depending upon the number of space co-ordinates required to specify the velocity fields.

One-dimensional flow is the type of flow in which flow parameters such as velocity is a function of time and one space coordinate only.

For Ex., $V=V(x,t)$ – 1-D, unsteady ; $V=V(x)$ – 1-D, steady

Two-dimensional flow is the type of flow in which flow parameters describing the flow vary in two space coordinates and time.

For Ex., $V=V(x,y,t)$ – 2-D, unsteady; $V=V(x,y)$ – 2-D, steady

Three-dimensional flow is the type of flow in which the flow parameters describing the flow vary in three space coordinates and time.

For Ex., $V=V(x,y,z,t)$ – 3-D, unsteady ; $V=V(x,y,z)$ – 3D, steady

CONTINUITY EQUATION

Rate of flow or discharge (Q) is the volume of fluid flowing per second. For incompressible fluids flowing across a section,

Volume flow rate, $Q = A \times V$ m³/s where A=cross sectional area and V= average velocity.

For compressible fluids, rate of flow is expressed as mass of fluid flowing across a section per second.

Mass flow rate (m) = (ρAV) kg/s where ρ = density.

Continuity equation is based on Law of Conservation of Mass. For a fluid flowing through a pipe, in a steady flow, the quantity of fluid flowing per second at all cross-sections is a constant.

Let v_1 = average velocity at section [1], ρ_1 = density of fluid at [1], A_1 = area of flow at [1]; Let v_2, ρ_2, A_2 be corresponding values at section [2].

$$\text{Rate of flow at section [1]} = \rho_1 A_1 v_1$$

$$\text{Rate of flow at section [2]} = \rho_2 A_2 v_2$$

$$\rho_1 A_1 v_1 = \rho_2 A_2 v_2$$

This equation is applicable to steady compressible or incompressible fluid flows and is called Continuity Equation. If the fluid is incompressible, $\rho_1 = \rho_2$ and the continuity equation reduces to $A_1 v_1 = A_2 v_2$

For steady, one dimensional flow with one inlet and one outlet,

$$\rho_1 A_1 v_1 - \rho_2 A_2 v_2 = 0$$

For control volume with N inlets and outlets

$$\sum_{i=1}^N (\rho_i A_i v_i) = 0 \text{ where inflows are positive and outflows are negative.}$$

Velocities are normal to the areas. This is the continuity equation for steady one dimensional flow through a fixed control volume

When density is constant, $\rho = \rho_0$

Problem 1.0

Given the velocity field $V = (4+xy+2t)i + 6x^3j + (3xt^2+z)k$. Find acceleration of a fluid particle at (2,4,-4) at $t=3$.

$$[dV/dt] = [\partial V/\partial t] + u[\partial V/\partial x] + v[\partial V/\partial y] + w[\partial V/\partial z]$$

$$u = (4+xy+2t); v = 6x^3; w = (3xt^2+z)$$

$$[\partial V/\partial x] = (yi + 18x^2j + 3t^2k); [\partial V/\partial y] = xi; [\partial V/\partial z] = k; [\partial V/\partial t] = 2i + 6xtk. \text{ Substituting,}$$

$$[dV/dt] = (2+4y+xy^2+2ty+6x^4)i + (72x^2+18x^3y+36tx^2)j + (6xt+12t^2+3xyt^2+6t^3+z+3xt^2)k$$

The acceleration vector at the point (2,4,-4) and time $t=3$ is obtained by substitution,

$$a. \quad 170i + 1296j + 572k; \text{ Therefore, } a_x = 170, a_y = 1296, a_z = 572$$

$$b. \quad \text{Resultant } |a| = [170^2 + 1296^2 + 572^2]^{1/2} \text{ units} = 1426.8 \text{ units.}$$

VELOCITY POTENTIAL AND STREAM FUNCTION

Velocity Potential Function is a Scalar Function of space and time co-ordinates such that its negative derivatives with respect to any direction give the fluid velocity in that direction.

$\phi = \phi(x, y, z)$ for steady flow.

$u = -(\partial \phi / \partial x)$; $v = -(\partial \phi / \partial y)$; $w = -(\partial \phi / \partial z)$ where u, v, w are the components of velocity in x, y and z directions.

In cylindrical co-ordinates, the velocity potential function is given by $u = -(\partial \phi / \partial r)$,

$v = (1/r)(\partial \phi / \partial \theta)$

The continuity equation for an incompressible flow in steady state is

$$(\partial u / \partial x + \partial v / \partial y + \partial w / \partial z) = 0$$

Substituting for u, v and w and simplifying,

$$(\partial^2 \phi / \partial x^2 + \partial^2 \phi / \partial y^2 + \partial^2 \phi / \partial z^2) = 0$$

Which is a Laplace Equation. For 2-D Flow, $(\partial^2 \phi / \partial x^2 + \partial^2 \phi / \partial y^2) = 0$

If any function satisfies Laplace equation, it corresponds to some case of steady incompressible fluid flow.

IRROTATIONAL FLOW AND VELOCITY POTENTIAL

Assumption of Ir-rotational flow leads to the existence of velocity potential. Consider the rotation of the fluid particle about an axis parallel to z-axis. The rotation component is defined as the average angular velocity of two infinitesimal linear segments that are mutually perpendicular to each other and to the axis of rotation.

Consider two-line segments \underline{x} , \underline{y} . The particle at P(x,y) has velocity components u,v in the x-y plane.

The angular velocities of \underline{x} and \underline{y} are sought.

The angular velocity of (\underline{x}) is $\{[v + (\partial v / \partial x) \underline{x} - v] / \underline{x}\} = (\partial v / \partial x)$ rad/sec

The angular velocity of (\underline{y}) is $- \{[u + (\partial u / \partial y) \underline{y} - u] / \underline{y}\} = -(u/y)$ rad/sec Counter clockwise direction is taken positive. Hence, by definition, rotation

component ($\underline{\omega}$) is $\underline{\omega} = 1/2 \{(\partial v / \partial x) - (\partial u / \partial y)\}$. The other two components are

$$x. \quad 1/2 \{(\partial w / \partial y) - (\partial v / \partial z)\}$$

$$y. \quad 1/2 \{(\partial u / \partial z) - (\partial w / \partial x)\}$$

The rotation vector $\underline{\omega} = \underline{i} \omega_x + \underline{j} \omega_y + \underline{k} \omega_z$.

The vorticity vector ($\underline{\Omega}$) is defined as twice the rotation vector $= 2 \underline{\omega}$

PROPERTIES OF POTENTIAL FUNCTION

$$\underline{\omega}_z = 1/2 \{(\partial v / \partial x) - (\partial u / \partial y)\}$$

$$\underline{\omega}_x = 1/2 \{(\partial w / \partial y) - (\partial v / \partial z)\}$$

$$y. \quad 1/2 \{(\partial u / \partial z) - (\partial w / \partial x)\};$$

Substituting $u = -(\partial \phi / \partial x)$; $v = -(\partial \phi / \partial y)$; $w = -(\partial \phi / \partial z)$; we get

$$\underline{\omega}_z = 1/2 \{(\partial^2 \phi / \partial x^2) - (\partial^2 \phi / \partial y^2) - (\partial^2 \phi / \partial x^2) - (\partial^2 \phi / \partial y^2)\} \\ = 1/2 \{-(\partial^2 \phi / \partial x \partial y) + (\partial^2 \phi / \partial y \partial x)\} = 0 \text{ since } \phi \text{ is a continuous function.}$$

Similarly, $\underline{\omega}_x = 0$ and $\underline{\omega}_y = 0$

All rotational components are zero and the flow is irrotational. – Therefore, irrotational flow is also called as Potential Flow.

If the velocity potential (ϕ) exists, the flow should be irrotational. If velocity potential function satisfies Laplace Equation, It represents the possible case of steady, incompressible, irrotational flow. Assumption of a velocity potential is equivalent to the assumption of irrotational flow.

Laplace equation has several solutions depending upon boundary conditions.

If ϕ_1 and ϕ_2 are both solutions, $\phi_1 + \phi_2$ is also a solution

$$\nabla^2(\phi_1) = 0, \nabla^2(\phi_2) = 0, \nabla^2(\phi_1 + \phi_2) = 0$$

Also if ϕ

is a solution, $C\phi$ is also a solution (where C=Constant)

STREAM FUNCTION (ψ)

Stream Function is defined as the scalar function of space and time such that its partial derivative with respect to any direction gives the velocity component at right angles to that direction. Stream function is defined only for two dimensional flows and 3-D flows with axial symmetry.

$$\left(\frac{\partial \psi}{\partial x}\right) = v ; \left(\frac{\partial \psi}{\partial y}\right) = -u$$

In Cylindrical coordinates, $u_r = (1/r) \left(\frac{\partial \psi}{\partial \theta}\right)$ and $u_\theta = \left(\frac{\partial \psi}{\partial r}\right)$

$$z = 0. \text{ Hence for 2-D flow, } \left(\frac{\partial^2 \psi}{\partial x^2}\right) + \left(\frac{\partial^2 \psi}{\partial y^2}\right)$$

Module-III

BOUNDARY LAYER CONCEPT AND CLOSED CONDUIT FLOW

FLOW PAST IMMERSED BODIES

Whenever a body is placed in a stream, forces are exerted on the body. Similarly, if the body is moving in a stationary fluid, force is exerted on the body.

Therefore, when there is a relative motion between the body and the fluid, force is exerted on the body.

Example: Wind forces on buildings, bridges etc., Force experienced by automobiles, aircraft, propeller etc.,

FORCE EXERTED BY FLOWING FLUID ON A STATIONARY BODY

Consider a stationary body placed in a stream of real fluid.

Let U = Free stream velocity.

Fluid will exert a Force F_R on the body.

The force is inclined at an angle to the direction of velocity.

The Force F_R can be resolved into TWO components – One in the direction of flow

(F_D) and the other perpendicular to it

(F_L).

$$R = F_L + F_D$$

Drag: The component of the total force (F_D)

(F_D)

F_D in the direction of motion is called as

) Drag is the force exerted by the fluid on the body in the direction of motion. Drag resists motion of the body or fluid.

Example: Wind resistance to a moving car, water resistance to torpedoes etc., Power is required to overcome drag and hence drag has to be reduced to a possible minimum.

Lift: The component of the total force in the direction perpendicular to the direction of motion. Lift is the force exerted by the fluid normal to the direction of motion.

Lift is zero for symmetrical flow.

Lift = Weight (in the case of an airplane in cruise)

Consider an elemental area (dA) on the surface of the body.

1. Pressure force (PdA) acts normal to the area dA .
2. Shear force (τdA) acts along the tangent to dA

□
3. (θ) = Angle made by force pdA with horizontal.

$$dF_D = (pdA)\cos(\theta) + (\tau dA)\sin(\theta)$$

Therefore, Total drag on the body
= F_D

$$D = \int (pdA)\cos(\theta) + \int (\tau dA)\sin(\theta) \text{ -----Equation (1)}$$

Total drag (or Profile drag) = Pressure drag (or form drag) + Friction drag.

The quantity $\int (pdA)\cos(\theta)$ is called the pressure drag or form drag and depends upon the form or shape of the body as well as the location of the separation point.

The quantity $\int (\tau dA)\sin(\theta)$ is called as the friction drag or skin friction drag and

□

depends upon the extent and character of the boundary layer. The sum of the pressure drag and the friction drag is called as total drag or profile drag.

In the case of a flat plate (Fig. a), $(\theta) = 90^\circ$. Hence, F_D is only the friction drag

If the plate is held normal to the plane (Fig. b), $(\theta) = 0^\circ$, Hence F_D is only the pressure drag

Lift = Force due to Pressure in the normal direction + Force due to shear in the normal direction.

$$= -(\rho p dA) \sin(\theta) + (\tau_0 dA) \cos(\theta) \text{ OR } F_L = -(\rho p dA) \sin(\theta) + (\tau_0 dA) \cos(\theta)$$

(Equation 2)

Equations (1) and (2) require detailed information regarding pressure distributions and shear stress distributions to determine F_D and F_L on the body.

As a simple alternative, Drag and Lift Forces are expressed as

$$F_D = C_D A (\rho U^2 / 2)$$

$$F_L = C_L A (\rho U^2 / 2)$$

Where C_D and C_L are called Coefficient of Drag and Coefficient of Lift respectively,

ρ = Density of fluid, U = Velocity of body relative to fluid

A = Reference area or projected area of the body perpendicular to the direction of flow or it is the largest projected area in the in the case of submerged body.

$(\rho U^2 / 2)$ = Dynamic pressure.

GENERAL EQUATIONS FOR DRAG AND LIFT

Let force 'F' is exerted by fluid on the body.

$F = F(L, \rho, \mu, k, U, g)$ where L = Length, ρ = Density, μ = Viscosity, k = Bulk modulus of elasticity, U = Velocity and g = Acceleration due to gravity. From dimensional analysis, we get,

$$F = \rho L^2 U^2 f(\text{Re}, \text{Fr}, \text{M})$$

Where Re = Reynolds Number = $(\rho UL / \mu)$,

Fr = Froude Number = (U / \sqrt{gL})

M = Mach Number = $(U / \sqrt{k/\rho}) = (U/a)$; a = Sonic velocity

If the body is completely submerged, Fr is not important. If Mach number is relatively low (say, < 0.25), M can be neglected.

Then, $F = \rho L^2 U^2 f(\text{Re})$ or

$$F = C_D L^2 (\rho U^2 / 2) = C_D (\rho U^2 / 2)$$

$$F = C_L L^2 (\rho U^2 / 2) = C_L$$

C_L and C_D are the coefficients of Lift and Drag respectively

TYPES OF DRAG

The type of drag experienced by the body depends upon the nature of fluid and the shape of the body:

1. Skin friction drag
2. Pressure drag
3. Profile drag
4. Wave drag
5. Induced drag

Skin Friction Drag: The part of the total drag that is due to the tangential shear stress (τ) acting on the surface of the body is called the skin friction drag. It is also

called as friction drag or shear drag or viscous drag.

Pressure Drag: The part of the total drag that is due to pressure on the body is called as Pressure Drag. It is also called as Form Drag since it mainly depends on the shape or form of the body

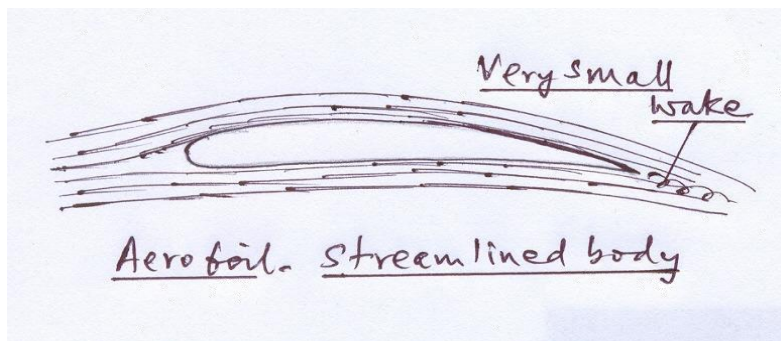

Fig. Flow over Bodies – Pressure Drag and Skin Friction Drag

For a streamlined body, pressure drag is small. Large part of drag is due to friction. Ex., Aerofoils, modern cars etc., - Streamlines match with the surface and there is very small wake behind the body.

For a bluff body, streamlines don't match with the surface. Flow separates and gives rise to large wake zone. Pressure drag is predominant compared to friction drag – Ex., Bus body.

Profile Drag or Total Drag is the sum of Pressure or Form drag and Skin Friction drag.

Wave Drag: When a body like ship moves through a fluid, waves are produced on the surface of the liquid. The drag caused due to these waves is called as wave drag. The wave drag is obtained by subtracting all other drags from the total drag measurements. The drag, which is caused by change in pressure due to a shock wave in supersonic flow, is also called as wave drag.

Induced Drag: When a body has a finite length (Ex., Wing of an airplane), the pattern of flow is affected due to the conditions of flow at the ends. The flow cannot be treated as two-dimensional, but has to be treated as three-dimensional flow. Due to this, body is subjected to additional drag. This drag, due to the three dimensional nature of flow and finite length of the body is called as Induced Drag.

Deformation Drag: If the body with a very small length (Ex., Sphere) moves at very low velocity through a fluid with high kinematics viscosity ($Re = (\rho UL / \mu)$ less than 0.1), the body experiences a resistance to its motion due to the wide spread deformation of fluid particles. This drag is known as Deformation Drag.

Problem –1.

A circular disc 3m in diameter is held normal to 26.4m/s wind velocity. What force is required to hold it at rest? Assume density of air = 1.2kg/m³, and $C_D = 1.1$.

$$\text{Force required to hold the disc} = \text{Drag} = F_D = C_D A (\rho U^2 / 2)$$

$$= 1.1 \times (0.32/4) \times (1.2 \times 26.42^2 / 2) = 3251.5 \text{ N}$$

Problem-2.

Calculate the power required to overcome the aerodynamic drag for the two cars both traveling at 90km/h using the following data.

Car (A) – $C_D = 0.8$, A (frontal) = 2m²,

Car (B) – $C_D = 0.4$, A (frontal) = 1.8m². Take $\rho = 1.164 \text{ kg/m}^3$.

For Car (A)

$$\text{Power} = \text{Force} \times \text{Velocity} = F \times U$$

$$= 90\text{km/hr} = 25\text{m/s.}$$

$$\text{Power} = C_D A (\rho U^2 / 2) \times U$$

$$= 0.8 \times 2 \times (1.164 \times 25^2 / 2) \times 25 = 14550\text{W} = 14.55\text{kW}$$

Similarly for Car (B),

$$\text{Power} = 0.4 \times 1.8 \times (1.164 \times 25^2 / 2) \times 25 = 6.55\text{kW}$$

Problem-3.

Experiments were conducted in a wind tunnel with a wind speed of 50km/h. on a flat plate of size 2m long and 1m wide. The plate is kept at such an angle that the co-efficient of lift and drag are 0.75 and 0.15 respectively. Determine (a) Lift force

(b) Drag force (c) Resultant force (d) Power required to maintain flow.

Take $\rho = 1.2 \text{ kg/m}^3$.

Given: $A = 2\text{m}^2$; $C_L = 0.75$; $C_D = 0.15$; $\rho = 1.2 \text{ kg/m}^3$; $U = 13.89\text{m/s}$

$$\text{Drag force} = F_D = C_D A (\rho U^2 / 2) = 34.72\text{N}$$

force = F

$$L = C_L A (\rho U^2 / 2) = 173.6\text{N}$$

$$\text{Resultant force} = F_R = (F_D^2 + F_L^2)^{1/2} = 177.03 \text{ N}$$

Power = F

$$D \times \dots$$

BOUNDARY LAYER CONCEPT

Ideal fluid theory assumes that fluid is ideal, zero viscosity and constant density. Results obtained don't match with experiments.

With ideal fluid, there is no drag force. However, in practice, drag force exists. In practice, fluids adhere to the boundary.

At wall, fluid velocity = wall velocity- this is called No Slip Condition. The velocity of the fluid is zero at the wall and goes on increasing as we go away from the wall if the wall is stationary.

This variation in velocity near the wall gives rise to shear stresses resulting in resistance to motion of bodies.

CONCEPT OF BOUNDARY LAYER

L.Prandtl developed Boundary Layer Theory

Boundary layer theory explains the drag force experienced by the body. The fluid in the vicinity of the surface of the body may be divided into two regions – (1) Boundary layer and (2) Potential flow or Irrotational flow region.

7

BOUNDARY LAYER

Boundary layer is a very thin layer of fluid in the immediate vicinity of the wall (or boundary). When a real fluid flows past a solid boundary, there develops a thin layer very close to the boundary in which the velocity rapidly increases from zero at the boundary (due to no slip condition) to the nearly uniform velocity in the free stream. This region is called Boundary layer. In this region, the effect of viscosity is predominant due to the high values of (du/dy) and most of the energy is lost in this zone due to viscous shear.

The layer of fluid which has its velocity affected by the boundary shear is called as Boundary Layer. A thin layer of fluid in the vicinity of the boundary, whose velocity is affected due to viscous shear, is called as the Boundary layer

1

2

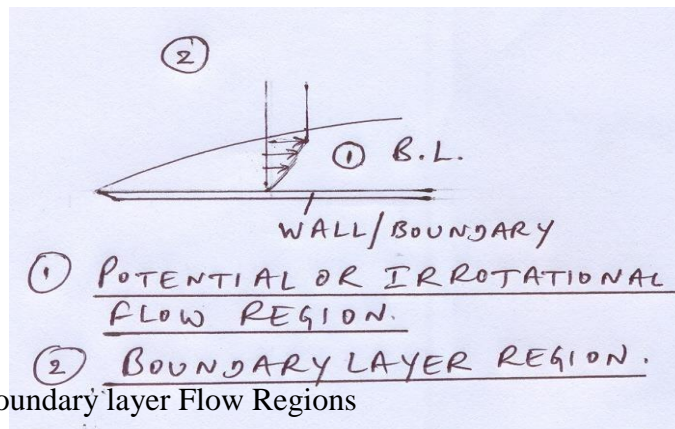

Fig. Potential and Boundary layer Flow Regions

POTENTIAL FLOW OR IRROTATIONAL FLOW REGION

The portion of the fluid outside the boundary layer where viscous effects are negligible is called potential flow or ir-rotational flow region. The flow in this region can be treated as Ideal Fluid Flow.

BOUNDARY LAYER ALONG A FLAT PLATE AND IT'S uCHARECTERISTICS

Consider a steady, uniform stream of fluid moving with velocity (U) on a flat plate. Let U = Free stream velocity or Ambient velocity. At the leading edge, the thickness of the boundary layer is zero. In the down stream direction, the thickness of the boundary layer (δ) goes on increasing as shown.

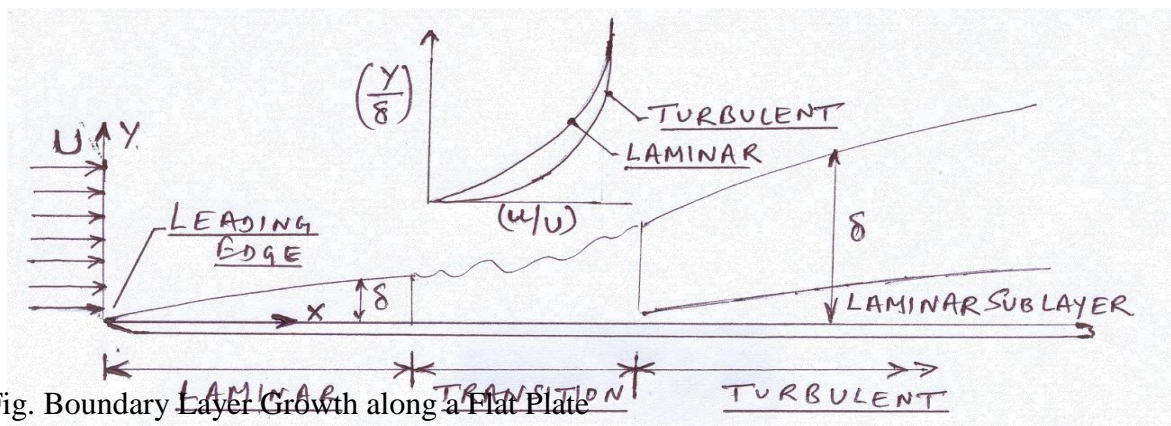

Fig. Boundary Layer Growth along a Flat Plate

Up to a certain length along the plate from the leading edge, boundary layer thickness increases and the boundary layer exhibits the characteristics of a laminar flow irrespective of whether the incoming flow is laminar or turbulent. – This is known as laminar boundary layer.

The thickness of the laminar boundary layer (δ) is given by (δ) = y (at $(u/U) = 0.99$) where u = local velocity.

The thickness of the laminar boundary layer is given by (δ) = $[5x/(Rex)^{0.5}]$

Where Rex = Reynolds number based on distance from the leading edge (x)

$Rex = (Ux/\nu)$; Therefore, (δ) = $5(x\nu/U)^{0.5}$

In the laminar boundary layer, the Newton's law of viscosity ($\tau = \mu (du/dy)$) is valid and the velocity distribution is parabolic in nature.

Beyond some distance from the leading edge, the laminar boundary layer becomes unstable and the flow in the boundary layer exhibits the characteristics between laminar and turbulent flows. This region is known as the transition region. After this region, the thickness of the boundary layer increases rapidly and the flow in the boundary layer exhibits the characteristics of the turbulent flow

This region is known as the turbulent boundary layer. In the turbulent boundary layer, the boundary layer thickness is given by

(δ) = $[0.377x/(Rex)^{0.2}]$

The velocity profile is logarithmic in the turbulent boundary layer.

The change from laminar to turbulent boundary layer depends mainly on $R_x = \frac{Ux}{\nu}$. The value of critical Reynolds number varies from 3×10^5 to 6×10^5 (for a flat plate). For all practical purposes, we can take $R_x = 5 \times 10^5$.

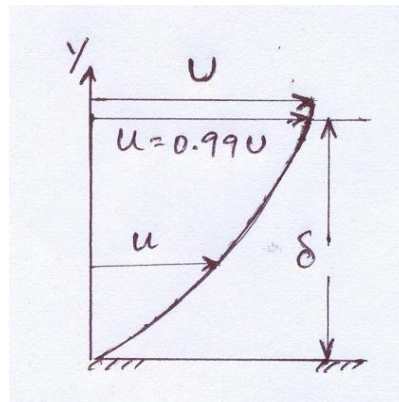

If the plate is smooth, the turbulent boundary layer consists of a thin layer adjacent to the boundary in which the flow is laminar. This thin layer is known as the laminar sub-layer.

The thickness of the laminar sub-layer (δ') is given by the laminar sub-layer, although very thin is an important factor in deciding whether a surface is hydro-dynamically smooth or rough surface.

FACTORS AFFECTING THE GROWTH OF BOUNDARY LAYERS

1. Distance (x) from the leading edge – Boundary layer thickness varies directly with the distance (x). More the distance (x), more is the thickness of the boundary layer.
2. Free stream velocity – Boundary layer thickness varies inversely as free stream velocity.
3. Viscosity of the fluid – Boundary layer thickness varies directly as viscosity.
4. Density of the fluid – Boundary layer thickness varies inversely as density.

THICKNESSES OF THE BOUNDARY LAYER

Boundary layer thickness (δ) - It is the distance from the boundary in which the local velocity reaches 99% of the main stream velocity and is denoted by (δ).

$$y = \delta \text{ when } u = 0.99U$$

Displacement Thickness (δ^*): It is defined as the distance perpendicular to the boundary by which the boundary will have to be displaced outward so that the actual discharge would be same as that of the ideal fluid past the displaced boundary. It is also defined as the distance measured perpendicular from the actual boundary such that the mass flux through this distance is equal to the deficit of mass flux due to boundary layer formation.

$$\text{Deficit of mass flow (discharge)} = \int_0^\delta (b \cdot dy)(U - u)$$

Total deficit of mass flow:

$$\Delta \dot{m} \propto \rho \int_0^\delta (b \cdot dy)(U - u) = \rho b \delta^* U$$

$$\delta^* =$$

$$\int_0^\delta (1 - u/U) dy$$

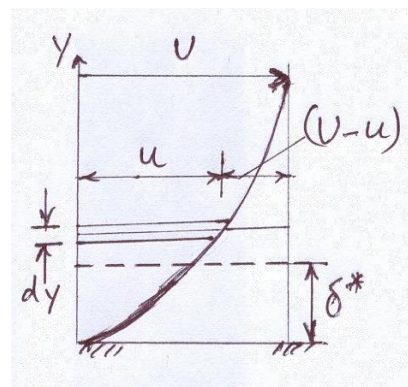

Fig. Displacement Thickness

Momentum thickness (θ): It is defined as the distance measured

perpendicular from the actual boundary such that the momentum flux through this distance is equal to the deficit of the momentum flux due to the boundary layer formation.

$$\text{Momentum deficit} = \int_0^\delta (b \cdot dy)(U - u)u$$

Total momentum deficit = Momentum through thickness (θ)

$$\Delta \dot{m} \propto \rho \int_0^\delta (b \cdot dy)(U - u)u = \rho b \theta U^2$$

$$\theta = \int_0^\delta \frac{u}{U} (1 - \frac{u}{U}) dy$$

Module-IV

FLUID MACHINES

Introduction and Working principle of hydraulic turbines

- Hydraulic turbines are the machines which convert the hydraulic energy of water into mechanical energy. Therefore, these may be considered as hydraulic motors or prime movers.
- Pump: it converts mechanical energy into hydraulic energy. The mechanical energy developed by the turbine is used in running an electric generator which is directly coupled to the shaft of the turbine. The electric generator thus generates electric power which is known as hydroelectric power.
- Electric Motor: Electric motor converts electrical energy to mechanical energy.

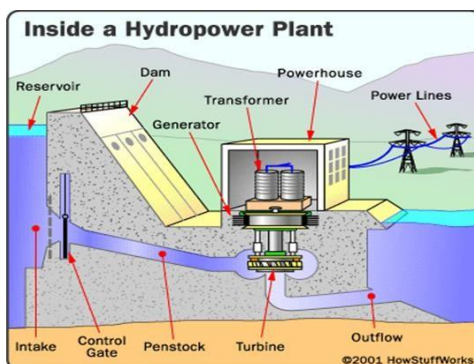

DEVELOPMENT OF TURBINES

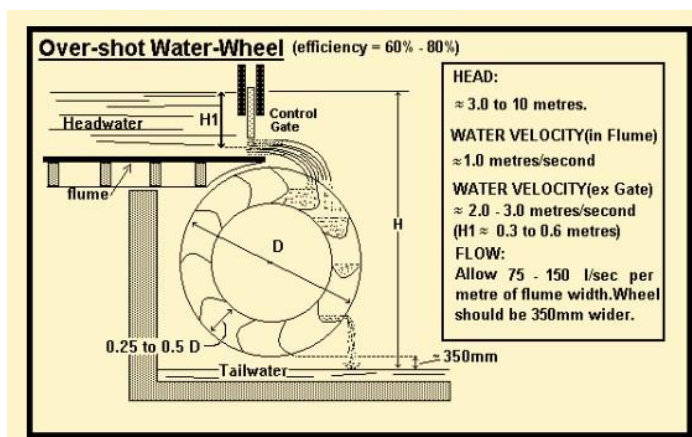

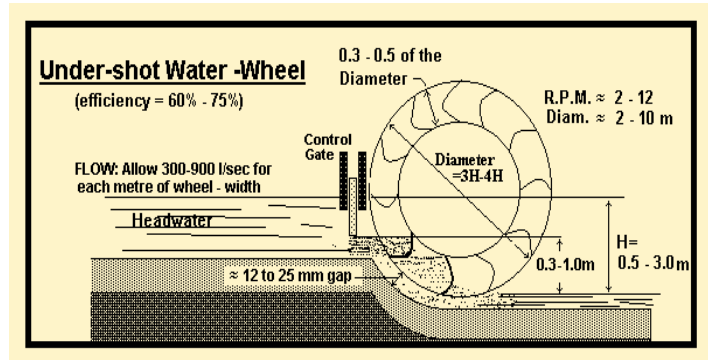

□ In the early days of water, pump development water wheels made of wood are widely used which uses either (falling water) potential energy or kinetic energy of the flowing stream of water. The wheel consists of series of straight vanes on its periphery, water was permitted to enter at the top and imbalance created by the weight of the water causes wheel to rotate (over shot wheel uses potential energy, under short wheel uses kinetic energy). Since, the low efficiency and low power generation and these could not be directly coupled to modern fast electric generators for the purpose of power generation. Therefore, the water wheels are completely replaced by modern hydraulic turbines, which will run at any head and desired speed enabling the generator to be coupled directly.

□ In general turbine consists of wheel called runner or rotor having a number of specially developed vanes or blades or buckets. The water possessing large amount of hydro energy when strikes the runner, it does the work on runner and causes it to rotate.

Classification of Hydraulic Turbines

1. According to the type of energy at the inlet
2. According to the direction of flow through runner
3. According to head at inlet
4. According to specific speed of turbine
5. According to Position of the shaft

1. According to the type of energy at the inlet

a) *Impulse turbine:*

□ All the available energy of the water is converted into kinetic energy by passing it through a contracting nozzle provided at the end of penstock

Ex: Pelton wheel turbine, Turgo-impulse turbine, Girard turbine, Bank turbine, Jonval turbine etc.

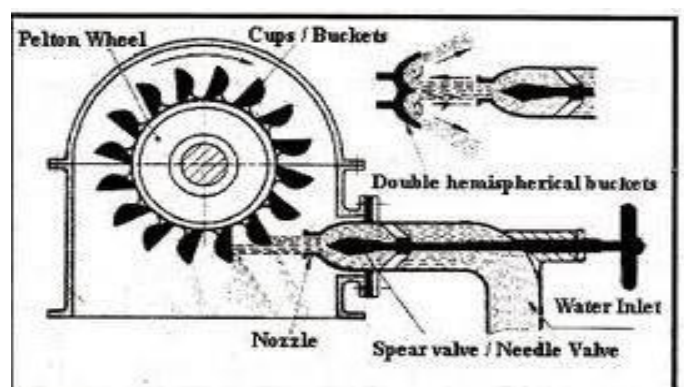

b) Reaction Turbine:

- At the entrance of the runner, only a part of the available energy of water is converted into kinetic energy and a substantial part remains in the form of pressure energy.
- As the water flow through the turbine pressure energy converts into kinetic energy gradually. Therefore the pressure at inlet of runner is higher than the pressure at outlet and it varies through out the passage of the turbine.
- For this gradual change of pressure to the possible the runner must be completely enclosed in a air-tight casing and the passage is entirely full of water throughout the operation of turbine
- The difference of pressure between the inlet and outlet of the runner is called reaction pressure and hence the turbines are known as reaction turbines.
- Ex: Francis turbine, Kaplan turbine, Thomson Turbine, Fourneyron turbine, Propeller turbine, etc

2. According to the direction of flow through runner:

- a) Tangential flow turbine
- b) Radial flow turbine
- c) Axial flow turbine
- d) Mixed flow turbine

a) Tangential flow turbine:

The water flows along the tangent to the path of rotation of the runner
Ex: Pelton wheel turbine

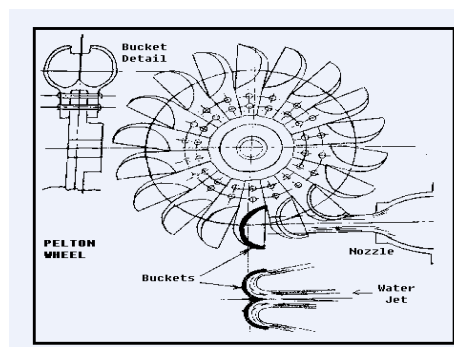

b) Radial flow Turbine

- The water flows in the radial direction through the runner.
- Inward radial flow turbine: The water enters the outer circumference and flows radially inwards towards the centre of the runner.
- Ex: Old Francis turbine, Thomson turbine, Girard turbine etc

- **Outward radial flow turbine:** The water enters at the centre and flows radially outwards towards the outer periphery of the runner.
- Ex: Fourneyron turbine.



c) Axial flow turbine:

■ The water flow through runner wholly and mainly along the direction parallel to the axis of rotation of the runner.

■ Ex: Kaplan turbine, Jonval, Girard axial flow turbine, Propeller turbine, etc

d) Mixed flow turbines

The water enters the runner at the outer periphery in the radial direction and leaves it at the centre of the axial direction parallel to the rotation of the runner.

Ex: Modern Francis turbine.

3. According to head at inlet:

a) High head turbines: These turbines work under very high heads 255m - 1770m and above. Requires relatively less quantity of water.

Ex: Pelton wheel turbine or impulse turbine.

b) Medium head turbines: These turbines are capable of working under medium heads ranging from 60m - 250m These turbines requires large quantity of water.

Ex: Francis Turbine

c) Low head turbines: these turbines are capable of working under the heads less than 60mts. These turbines requires large quantity of water.

Ex: Kaplan turbine, propeller turbine.

a) Low specific speed turbines: specific speed turbine varies from 8.5 to 30.

Ex: Pelton wheel turbine

b) Medium specific speed turbines: specific speed varies from 50 to 340

Ex: Francis turbine.

c) High specific speed turbines: specific speed varies from 255-860.

Ex: Kaplan and propeller turbine.

5) According to the position of the shaft:

a) Horizontal disposition of shaft

b) Vertical disposition of shaft.
Turbine Shaft

PELTON WHEEL TURBINE

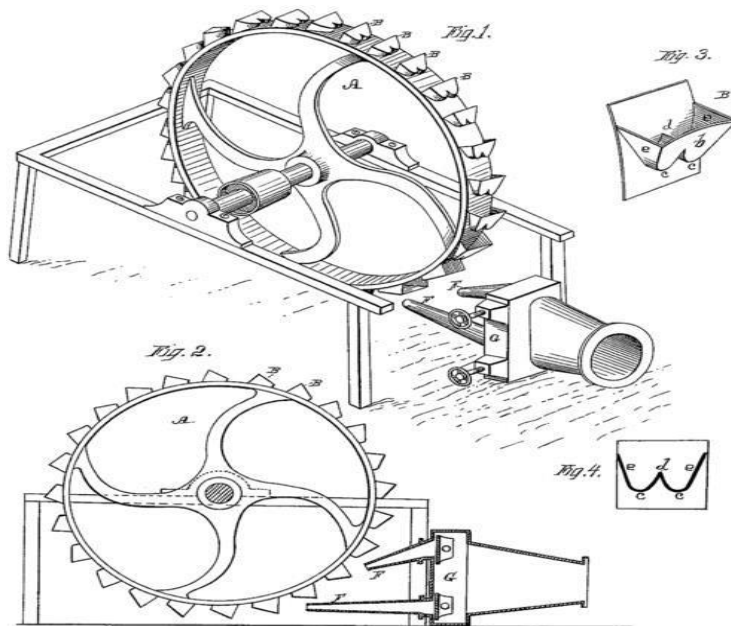

- This is named after Lester A. Pelton, American engineer who contributed much to its development in about 1880. It is well suited for operating under high heads.
- It's an impulse, high head, low specific speed and tangential flow turbine.
- The runner consists of a circular disc with a number of buckets evenly spaced around its periphery.
- The buckets have a shape of double semi-ellipsoidal cups. Each bucket is divided into 2 symmetrical parts by sharp edged ridge known as splitter.
- One or more nozzles are mounted so that each directs a jet along a tangential to the pitch circle of runner or axis of blades.
- The jet of water impinges on the splitter, which divides jet into equal halves, each of which after flowing around the smooth inner surface of the bucket leaves at its outer edge.
- The buckets are so shaped that the angle at the outlet lip varies from 10 to 20 degrees. So that the jet of outer deflects through 160 to 170. The advantage of having double cup-shaped bucket is that

the axial thrust neutralizes each other being equal and opposite and having bearing supporting the wheel shaft are not supported to any axial thrust or end thrust.

■ The back of the bucket is shaped that as it swings downward into the jet no water is wasted by splashing.

■ At the lower tips of the bucket a notch is cut which prevents the jet striking the preceding bucket and also avoids the deflection of water towards the centre of the wheel.

■ For low heads buckets are made of C.I, for high heads buckets are made of Cast Steel ,bronze, stainless steel.

■ In order to control the quantity of water striking the runner, the nozzle is fitted at the end of the penstock is provided with a spear valve having streamlined head which is fixed at the end of the rod.

■ When the shaft of pelton wheel is horizontal, not more than two jets are used if the shaft vertical six number of jets are possible.

■ A casing is made of C.I or fabricated steel plates is usually provided for a pelton wheel to prevent splashing of water, to lead water to the tail race and also act as safeguard against accidents.

■ Large pelton wheels are usually equipped with a small break nozzle which when opened directs a jet of water on the back of the buckets, thereby bringing the wheel quickly to rest after it is shut down, otherwise it takes considerable time to come to rest.

REACTION TURBINES:

■ In reaction turbines, the available energy of water at inlet of the turbine is sum of pressure energy and kinetic energy and during the flow of water through the runner a part of pressure energy is converted into kinetic energy, such type of turbine is reaction turbine. Ex: Francis Turbine, Kaplan Turbine, Propeller Turbine, etc

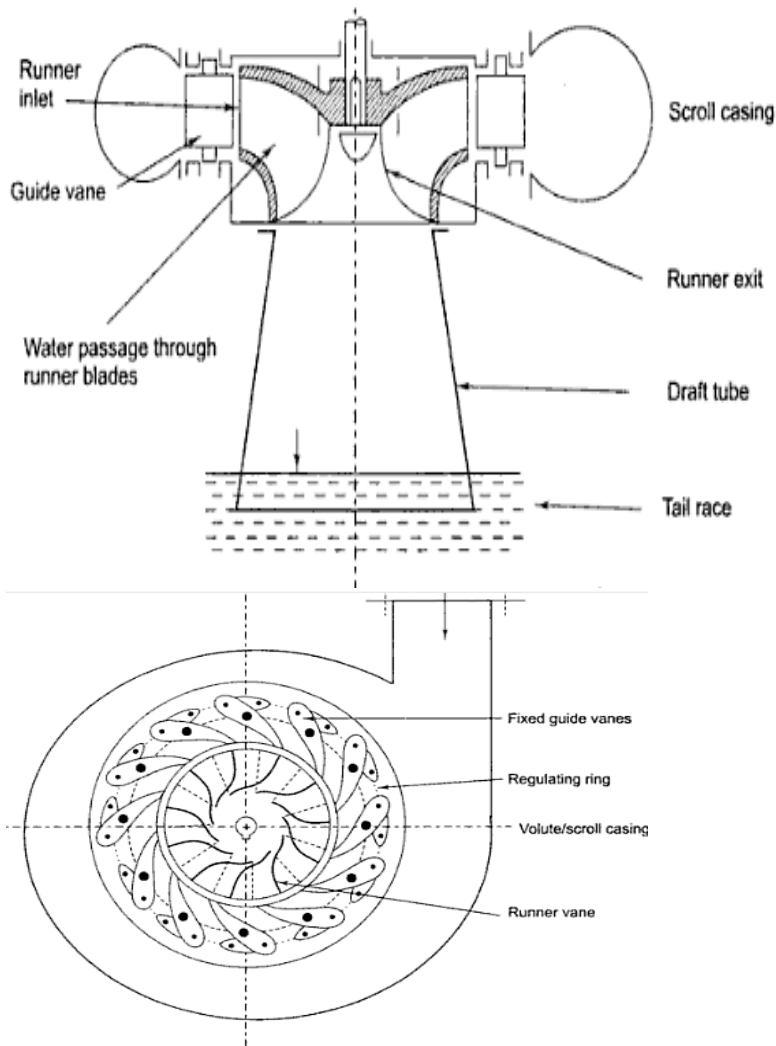

Sectional view of Francis Turbine

The main components of Francis Turbine:

Scroll Casing:

- The water from the penstock enters the scroll casing or spiral casing which completely surrounds the runner. The purpose of casing is to provide even distribution of water around the circumference of the runner and to maintain constant velocity of water so distributed.

- In order to maintain constant velocity of water through out its path around the runner, the cross-sectional area of casing is gradually decreased. The casing is made of cast steel or plate steel.

2. Stay Ring:

-From the scroll casing the water passes through a speed ring or stray ring. Stay ring consists of outer and lower ring held together by series of fixed vanes called stay vanes.

- Number of stay vanes usually half of the number of guide vanes. Stay vane performs two functions, one is to direct the water from the scroll casing to the guide vanes and other is to rest the load imposed upon it by the internal pressure of water and the weight of the turbine and electrical generator and transmits the same to the foundation. Speed ring is made of C.I or C.S.

3. Guide Vanes:

-From the stay ring water passes through a series of guide vanes provided around the periphery of the runner. The function of guide vanes is to regulate the quantity of water supplied to the runner and to direct the water on to the runner with design angle.

- The guide vanes are airfoil shaped and made of C.S or S.S or P.S. Each guide vane is provided with two stems; the upper stem passes through head cover and lower stem seats in bottom ring. By a system of levers and links all the guide vanes may be turned about their stems, so as to alter the width of the passage between the adjacent guide vanes, thereby allowing a variable quantity of water to strike the runner. The guide vanes are operated either by means of a wheel or automatically by a governor.

4. RUNNER:

-The runner of a Francis turbine consists of a series of a curved vanes (from 16 to 24) evenly arranged around the circumference in the annular space between two plates.

-The vanes are so shaped that water enters the runner radially at the outer periphery and leaves it axially at the inner periphery.

-The change in the direction of flow of water from radial to axial, as it passes through the runner, produces a circumferential force on the runner which makes the runner to rotate and thus contributes to the useful output of the runner.

-Runner vanes are made of SS and other parts are made of CI or CS

- The runner is keyed to a shaft which is usually of forged steel. The torque produced by the runner is transmitted to the generator through the shaft which is usually connected to the generator shaft by a bolted flange connection.

and requires large quantity of water to develop large amount of power. Since it is a reaction turbine, it operates in an entirely closed conduit from head race to tail race.

The main components of a Kaplan turbine

Scroll Casing

Guide vanes Mechanism

Hub with vanes or runner of turbine, and

Draft Tube

The function of above components is same as that of Francis turbine

The water from the penstock enters the scroll casing and then moves to the guide vanes. From the guide vanes, the water turns through 90° and flows axially through the runner.

The runner of a Kaplan turbine has four or six blades (eight in exceptional cases). The blades attached to a hub are so shaped that water flows axially through the runner.

The adjustment of the runner blades is usually carried out automatically by means of a servomotor operating inside the hollow coupling of turbine and generator shaft.

When both guide vane angle and runner blade angle may varied, a high efficiency can be maintained. Even at part load, when a lower discharge is flowing through the runner, a high efficiency can be attained in case of Kaplan turbine.

Simultaneously the guide vane and runner vane angles are adjusted the water under all the working conditions flows through the runner blades without shock. as such the eddy losses which inevitable in Francis turbine and propeller turbines are almost completely eliminated in a Kaplan turbine.

Module-V
DIMENSIONAL ANALYSIS AND PUMPS

CENTRIFUGAL PUMPS

A pump is a hydraulic machine which converts mechanical energy into hydraulic energy or pressure energy.

A centrifugal pump is also known as a Rotodynamic pump or dynamic pressure pump. It works on the principle of centrifugal force. In this type of pump the liquid is subjected to whirling motion by the rotating impeller which is made of a number of backward curved vanes. The liquid enters this impeller at its center or the eye and gets discharged into the casing enclosing the outer edge of the impeller. The rise in the pressure head at any point/outlet of the impeller is Proportional to the square of the tangential velocity of the liquid at that point.

Hence at the outlet of the impeller where the radius is more the rise In pressure head will be more and the liquid will be discharged at the outlet with a high pressure head. Due to this high pressure head, the liquid can be lifted to a higher level. Generally centrifugal pumps are made of the radial flow type only. But there are also axial flow or propeller pumps which are particularly adopted for low heads. Advantages of centrifugal pumps:-

1. Its initial cost is low
2. Efficiency is high.
3. Discharge is uniform and continuous
4. Installation and maintenance is easy.
5. It can run at high speeds, without the risk of separation of flow

Classification of centrifugal pumps

Centrifugal pumps may be classified

Into the following types

1. According to casing design

- a. Volute pump b) diffuser or turbine pump
2. According to number of impellers
- a. Single stage pump b) multistage or multi impeller pump
3. According to number of entrances

to the impeller:

- a. Single suction pump
- b. Double suction pump
4. According to disposition of shaft
- a. Vertical shaft pump
- b. Horizontal shaft pump
5. According to liquid handled
- a. Semi open impeller
- b. Open impel

6. According to specific speed

- a. Low specific speed or radial flow impeller pump
- b. Shrouded impeller
- c. Medium specific speed or mixed flow impeller pump
- c. High specific speed or axial flow type or propeller pump.

7. According to head (H) Low

head if $H < 15\text{m}$

Medium head if $15 < H < 40\text{m}$

High head if $H > 40\text{m}$

In the case of a volute pump a spiral casing is provided around

the impeller. The water which leaves the vanes is directed to flow in the volute chamber circumferentially. The area of the volute chamber gradually increases in the direction flow. Thereby the velocity reduces and hence the pressure increases. As the water reaches the delivery pipe a considerable part of kinetic energy is converted into pressure energy. However, the eddies are not completely avoided, therefore some loss of energy takes place due to the continually increasing quantity of water through the volute chamber. In the case of a diffuser pump the guide wheel containing a series of guide vanes or diffuser is the additional component. The diffuser blades which provides gradually enlarging passages surround the impeller periphery. They serve to augment the process of pressure built up that is normally achieved in the volute casing. Diffuser pumps are also called turbine pumps in view of their resemblance to a reaction turbine.

Multistage pumps and vertical shaft deep-well pumps fall under this category. Centrifugal pumps can normally develop pressures upto 1000kpa (100m). If higher pressures are required there are three options. a) Increase of impeller diameter. b) Increase of Rpm. c) Use of two or more impellers in series.

The pump looks clumsy in option (a). The impeller material is heavily stressed in option (b) The third choice is the best and is generally adopted, the impellers which are usually of the same size are mounted on the same shaft. The unit is called a multistage pump. It discharges the same quantity of fluid as a single stage pump but the head developed is high. There are centrifugal pumps upto 54 stages. However, generally not more than 10 stages are required. In the case of the double suction impeller, two impellers are set back to back. The two suction eyes together reduce the intake. The two suction eyes together reduce the intake velocity reduce the risk of cavitations.

Mixed flow type double suction axial flow pumps besides are capable of developing higher heads. For convenience of operation and maintenance, horizontal shaft settings are the preferred setups for centrifugal pumps. The exceptions are deep-well turbine pumps and axial flow pumps, these have vertical shafts. Restricted space conditions usually require a vertical shaft setting. Centrifugal impellers usually have vanes fitted between the shroudes or plate. The crown plate has the suction eye and the base plate is mounted on a sleeve which is keyed to the shaft.

An impeller without the crown plate is called the non-clog or semi- open impeller. In an open impeller both crown plate and the base plate are absent.

Only clear liquids, can be safely pumped by a shrouded impeller pump. The semi-open impeller is useful for pumping liquids containing suspended solids, such as sewage, molasses or paper pulp. The open-vane impeller pump is employed for dredging operations in harbours and rivers. Shrouded and semi open impellers may be made of cast iron Or cast steel. Open vane impellers are usually made of forged steel. If the liquid pumped are corrosive, brass, bronze or gun metal are the best materials for making the impellers.

A radial flow impeller has small specific speeds (300 to 1000) & is suitable for discharging relatively small quantities of flow against high heads. The direction of flow at exit of the impeller is radial. The mixed flow type of impellers has a high specific speed (2500 to 5000), has large inlet diameter D and impeller width B to handle relatively large discharges against medium heads. The axial flow type or propeller impellers have the highest speed range (5000 to 10,000). They are capable of pumping large discharges against small heads. The specific speed of radial pump will be $10 < N_s < 80$, Axial pump $100 < N_s < 450$, Mixed flow pump $80 < N_s < 160$.

Components of a centrifugal pump

The main components of a centrifugal pump are:

- i. Impeller
- ii) Casing
- iii) Suction pipe
- iv) Foot valve with strainer,
- v) Delivery pipe
- vi) Delivery valve.

Impeller is the rotating component of the pump. It is made up of a series of curved vanes. The impeller is mounted on the shaft connecting an electric motor.

Casing is an air tight chamber surrounding the impeller. The shape of the casing is designed in such a way that the kinetic energy of the impeller is gradually changed to potential energy. This is achieved by gradually increasing the area of cross section in the direction of flow.

Suction pipe It is the pipe connecting the pump to the sump, from where the liquid has to be lifted up.

Foot valve with strainer the foot valve is a non-return valve which permits the flow of the liquid from the sump towards the pump. In other words the foot valve opens only in the upward direction.

The strainer is a mesh surrounding the valve, it prevents the entry of debris and silt into the pump.

Delivery pipe is a pipe connected to the pump to the overhead tank.

Delivery valve is a valve which can regulate the flow of liquid from the pump.

Priming of a centrifugal pump

Priming is the process of filling the suction pipe, casing of the pump and the delivery pipe upto the delivery valve with the liquid to be pumped.

If priming is not done the pump cannot deliver the liquid due to the fact that the head generated by the Impeller will be in terms of meters of air which will be very small (because specific weight of air is very much smaller than that of water).

Priming of a centrifugal pump can be done by any one of the following methods:

- i. Priming with suction/vacuum pump.
- ii) Priming with a jet pump.
- iii) Priming with separator.
- iv) Automatic or self priming.

Heads on a centrifugal pump:

Suction head (hs): it is the vertical distance between the liquid level in the sump and the centre line of the pump. It is expressed as meters.

Delivery head (hd): It is the vertical distance between the centre line of the pump and the liquid level in the overhead tank or the supply point. It is expressed in meters.

Static head (Hs): It is the vertical difference between the liquid levels in the overhead tank and the sump, when the pump is not working. It is expressed as meters.

Therefore, $H_S = (h_s + h_d)$

Friction head (hf): It is the sum of the head loss due to the friction in the suction and delivery pipes. The friction loss in both the pipes is calculated using the Darcys equation, $h_f = (fLV^2/2gD)$.

Total head (H): It is the sum of the static head H_s , friction head (h_f) and the velocity head in the delivery pipe ($V_d^2/2g$). Where, V_d =velocity in the delivery pipe.