

**PPTs on**  
**Probability Theory and Stochastic Process**  
**B.TECH III SEM-ECE**  
**IARE-R16**

By

- Dr. M V Krishna Rao, Professor
- Mrs. G Ajitha, Assistant Professor

# SOURCES



1. Probability, Random Variables and Random Signal Principles-by Peyton Z. Peebles, McGraw-Hill (2<sup>nd</sup> Indian edition)
2. IARE – PTSP Lectures Notes AY2018-19.
3. IARE – PTSP Lectures Notes AY2019-20.
4. Unknown Web sources.

# **MODULE-I**

# **Probability and Random Variable**

# Introduction to Set



- Set: A set is a well defined collection of objects. These objects are called elements or members of the set. Usually uppercase letters are used to denote sets.
- The set theory was developed by George Cantor in 1845-1918. Today, it is used in almost every branch of mathematics and serves as a fundamental part of present-day mathematics.
- In everyday life, we often talk of the collection of objects such as a bunch of keys, flock of birds, pack of cards, etc.
- In mathematics, we come across collections like natural numbers, whole numbers, prime and composite numbers.

# Laws in set theory



- $A \cap B = B \cap A$  (Commutative law)
- $(A \cap B) \cap C = A \cap (B \cap C)$  (Associative law)
- $\Phi \cap A = \Phi$  (Law of  $\Phi$ )
- $U \cap A = A$  (Law of  $U$ )
- $A \cap A = A$  (Idempotent law)
- $A \cap (B \cup C) = (A \cap B) \cup (A \cap C)$  (Distributive law) Here  $\cap$  distributes over  $\cup$
- Also,  $A \cup (B \cap C) = (A \cup B) \cap (A \cup C)$  (Distributive law) Here  $\cup$  distributes over  $\cap$

# Probability



- Experiment:

In probability theory, an experiment or trial (see below) is any procedure that can be infinitely repeated and has a well-defined set of possible outcomes, known as the sample space.

- An experiment is said to be random if it has more than one possible outcome, and deterministic if it has only one.
- A random experiment that has exactly two (mutually exclusive) possible outcomes is known as a Bernoulli trial.

# Experiment

<b>Experiment</b>	<b>Outcomes</b>
Flip a coin	Heads, Tails
Exam Marks	Numbers: 0, 1, 2, ..., 100
Assembly Time	$t > 0$ seconds
Course Grades	F, D, C, B, A, A+

# Random Experiment



- An experiment is a random experiment if its outcome cannot be predicted precisely. One out of a number of outcomes is possible in a random experiment.
- A single performance of the random experiment is called a trial. Random experiments are often conducted repeatedly, so that the collective results may be subjected to statistical analysis.
- A fixed number of repetitions of the same experiment can be thought of as a composed experiment, in which case the individual repetitions are called trials.
- For example, if one were to toss the same coin one hundred times and record each result, each toss would be considered a trial within the experiment composed of all hundred tosses.



# Relative frequency, Experiments



- Relative Frequency:

Random experiment with sample space  $S$ . we shall assign non-negative number called probability to each event in the sample space. Let  $A$  be a particular event in  $S$ . then “the probability of event  $A$ ” is denoted by  $P(A)$ .

- Suppose that the random experiment is repeated  $n$  times, if the event  $A$  occurs  $n_A$  times, then the probability of event  $A$  is defined as “Relative frequency
- Event  $A$  is defined as

$$P(A) = \lim_{n \rightarrow \infty} \frac{n_A}{n}$$

# Sample Space



- Sample Space: The sample space is the collection of all possible outcomes of a random experiment. The elements of are called sample points. A sample space may be finite, countable infinite or uncountable.
- A list of exhaustive [don't leave anything out] and mutually exclusive outcomes [impossible for 2 different events to occur in the same experiment] is called a sample space and is denoted by  $S$ .
- The outcomes are denoted by  $O_1, O_2, \dots, O_k$
- Using notation from set theory, we can represent the sample space and its outcomes as:

$$S = \{O_1, O_2, \dots, O_k\}$$

# Sample Space



- Given a sample space  $S = \{O_1, O_2, \dots, O_k\}$ , the probabilities assigned to the outcome must satisfy these requirements:
  - (1) The probability of any outcome is between 0 and 1  
i.e.  $0 \leq P(O_i) \leq 1$  for each  $i$ , and
  - (2) The sum of the probabilities of all the outcomes equals 1  
i.e.  $P(O_1) + P(O_2) + \dots + P(O_k) = 1$

# Discrete and Continuous Sample Spaces



- Probability assignment in a discrete sample space: Consider a finite sample space  $S$ . Then the sigma algebra is defined by the power set of  $S$ . For any elementary event  $s$ , we can assign a probability  $P(s)$  such that, For any event  $A$ , we can define the probability

# Continuous sample space



- Suppose the sample space  $S$  is continuous and uncountable. Such a sample space arises when the outcomes of an experiment are numbers. For example, such sample space occurs when the experiment consists in measuring the voltage, the current or the resistance.

# Events



- The probability of an event is the sum of the probabilities of the simple events that constitute the event.
- E.g. (assuming a fair die)  $S = \{1, 2, 3, 4, 5, 6\}$  and  $P(1) = P(2) = P(3) = P(4) = P(5) = P(6) = 1/6$
- Then:  $P(\text{EVEN}) = P(2) + P(4) + P(6) = 1/6 + 1/6 + 1/6 = 3/6 = 1/2$

# Types of Events

## 1. Exhaustive Events:

A set of events is said to be exhaustive, if it includes all the possible events. Ex. In tossing a coin, the outcome can be either Head or Tail and there is no other possible outcome. So, the set of events  $\{ H , T \}$  is exhaustive.

## 2. Mutually Exclusive Events:

Two events, A and B are said to be mutually exclusive if they cannot occur together. i.e. if the occurrence of one of the events precludes the occurrence of all others, then such a set of events is said to be mutually exclusive. If two events are mutually exclusive then the probability of either occurring is

# Types of Events

## 3. Equally Likely Events:

If one of the events cannot be expected to happen in preference to another, then such events are said to be Equally Likely Events. ( Or) Each outcome of the random experiment has an equal chance of occurring.

Ex. In tossing a coin, the coming of the head or the tail is equally likely

## 4. Independent Events:

Two events are said to be independent, if happening or failure of one does not affect the happening or failure of the other. Otherwise, the events are said to be dependent.



# Probability Definitions and Axioms



Relative frequency Definition:

Consider that an experiment  $E$  is repeated  $n$  times, and let  $A$  and  $B$  be two events associated with  $E$ . Let  $n_A$  and  $n_B$  be the number of times that the event  $A$  and the event  $B$  occurred among the  $n$  repetitions respectively. The relative frequency of the event  $A$  in the ' $n$ ' repetitions of  $E$  is defined as

$$f(A) = n_A / n$$

# Axioms of Probability



- The Relative frequency has the following properties:
- $0 \leq f(A) \leq 1$
- $f(A) = 1$  if and only if  $A$  occurs every time among the  $n$  repetitions.
- If an experiment is repeated  $n$  times under similar conditions and the event  $A$  occurs in  $n_A$  times, then the probability of the event  $A$  is defined as

# Joint probability

- Joint probability:

Joint probability is defined as the probability of both A and B taking place, and is denoted by  $P(AB)$  or  $P(A \cap B)$ .

- probability notation:  $P(AB) = P(A | B) * P(B)$

# Conditional Probability



- Conditional probability is used to determine how two events are related; that is, we can determine the probability of one event given the occurrence of another related event.
- Experiment: random select one student in class.
- $P(\text{randomly selected student is male})$
- $P(\text{randomly selected student is male/student is on 3}^{\text{rd}} \text{ row})$
- Conditional probabilities are written as  $P(A | B)$  and read as “the probability of A given B” and is calculated as

$$P(A | B) = \frac{P(A \text{ and } B)}{P(B)}$$

# Bayes' Theorem



- Bayes' Law is named for Thomas Bayes, an eighteenth century mathematician.
- In its most basic form, if we know  $P(B | A)$ ,
- we can apply Bayes' Law to determine  $P(A | B)$
- Bayes' theorem centers on relating different conditional probabilities. A conditional probability is an expression of how probable one event is given that some other event occurred (a fixed value).
- For a joint probability distribution over events  $A$  and  $B$  ,  $P(A \wedge B)$ , the conditional probability of given is defined as

# Bayes' theorem



$$P(A|B) = \frac{P(A \cap B)}{P(B)}$$

- Note that  $P(A \cap B)$  is the probability of both A and B occurring, which is the same as the probability of A occurring times the probability that B occurs given that A occurred  $P(B|A) \cdot P(A)$
- Using the same reasoning  $P(A \cap B)$ , is *also* the probability that B occurs times the probability that A occurs given that B occurs:  $P(A|B) \cdot P(B)$  The fact that these two expressions are equal leads to Bayes' Theorem. Expressed mathematically, this is:

$$\begin{aligned} P(A|B) &= \frac{P(A \cap B)}{P(B)}, \text{ if } P(B) \neq 0, \\ P(B|A) &= \frac{P(B \cap A)}{P(A)}, \text{ if } P(A) \neq 0, \\ \Rightarrow P(A \cap B) &= P(A|B) \times P(B) = P(B|A) \times P(A), \\ \Rightarrow P(A|B) &= \frac{P(B|A) \times P(A)}{P(B)}, \text{ if } P(B) \neq 0. \end{aligned}$$

# Bayes' theorem



- The probabilities  $P(A)$  and  $P(A^c)$  are called prior probabilities because they are determined prior to the decision about taking the preparatory course.
- The conditional probability  $P(A | B)$  is called a posterior probability (or revised probability), because the prior probability is revised after the decision about taking the preparatory course.

# Random variable

- A (real-valued) random variable, often denoted by  $X$  (or some other capital letter), is a function mapping a probability space  $(S, P)$  into the real line  $R$ . This is shown in next slide.
- Associated with each point  $s$  in the domain  $S$  the function  $X$  assigns one and only one value  $X(s)$  in the range  $R$ . (The set of possible values of  $X(s)$  is usually a proper subset of the real line; i.e., not all real numbers need occur. If  $S$  is a finite set with  $m$  elements, then  $X(s)$  can assume at most  $m$  different values as  $s$  varies in  $S$ .)



# RV in graphical representation

A random variable: a function

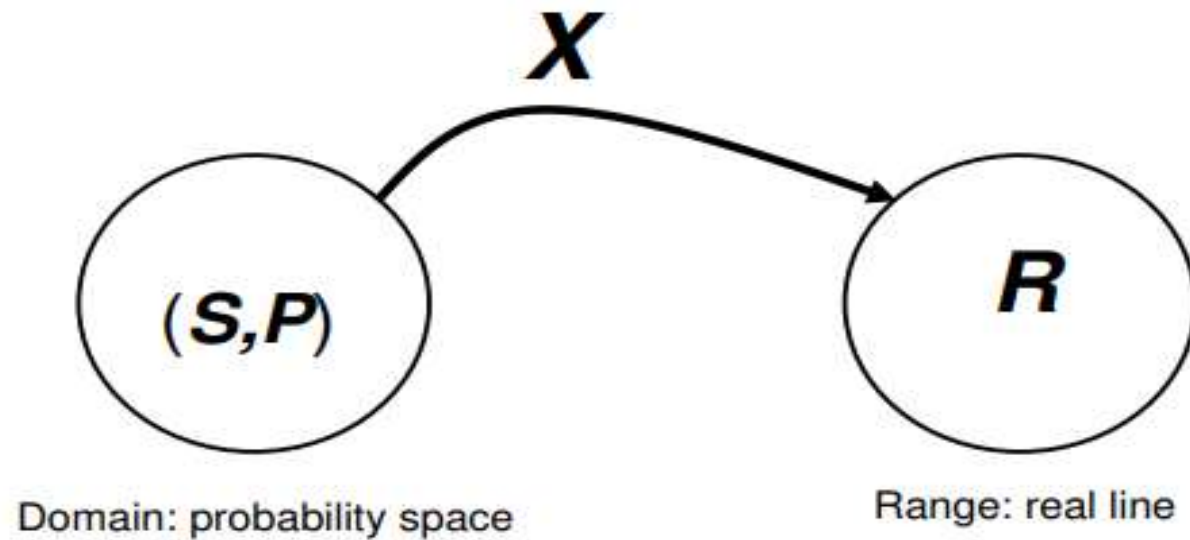

# RV in graphical representation

## Random variable

- A numerical value to each outcome of a particular experiment

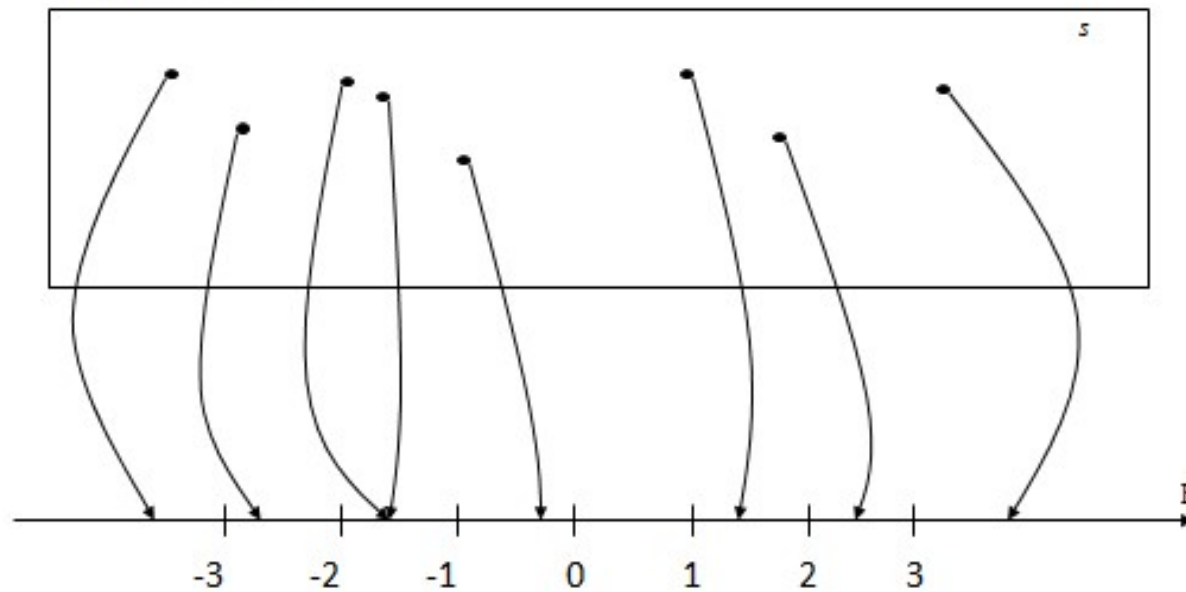

# Discrete random variable

- A random variable is called a discrete random variable if it is piece-wise constant. Thus it is flat except at the points of jump discontinuity. If the sample space is discrete the random variable defined on it is always discrete.

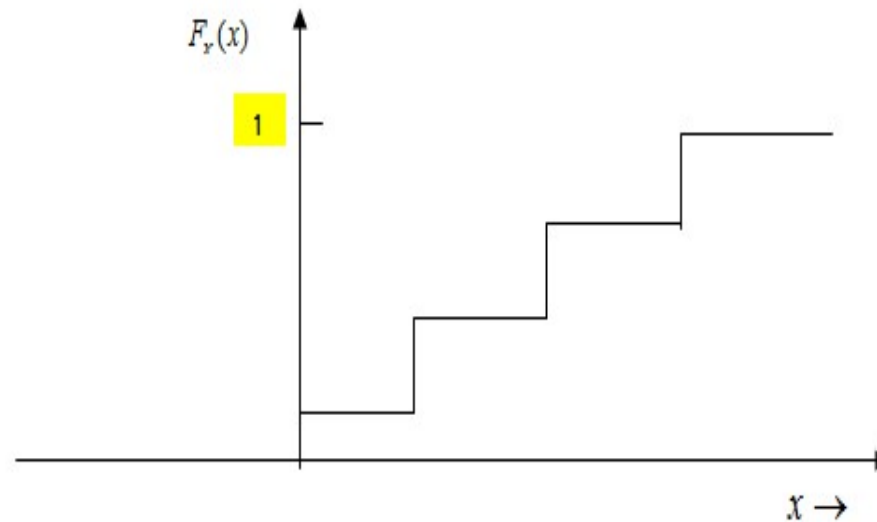

# Continuous random variable

- $X$  is called a continuous random variable if it is an absolutely continuous function of  $x$ . Thus  $F_x(x)$  is continuous everywhere on  $\mathbb{R}$  and exists everywhere except at finite or countable infinite points.

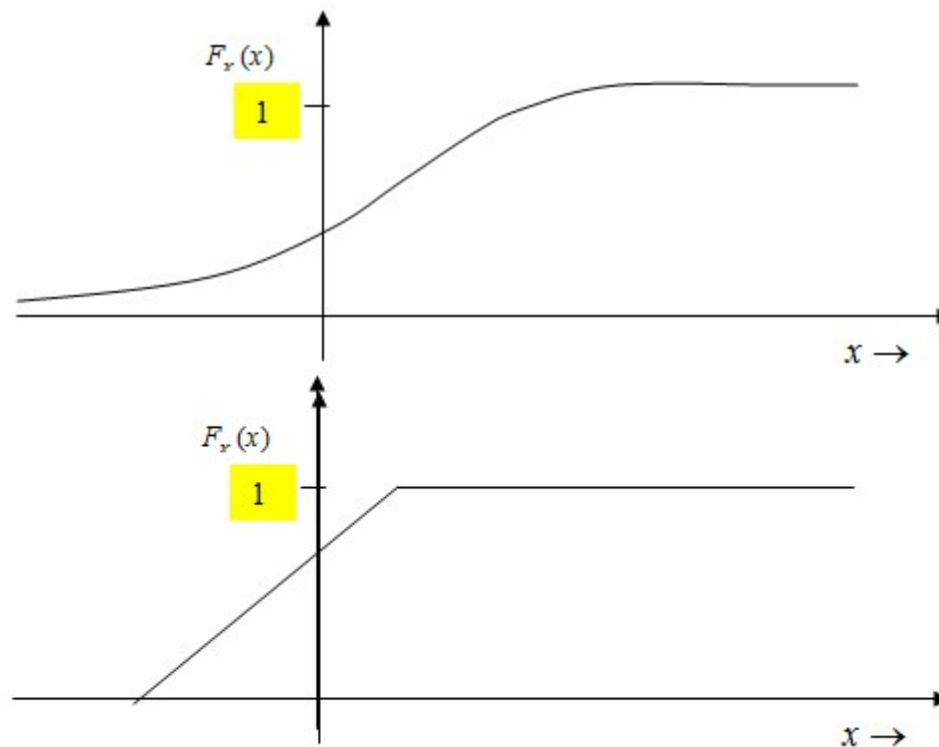

# Mixed random variable

- $X$  is called a mixed random variable if has jump discontinuity at countable number of points and it increases continuously at least at one interval of values of  $x$ . For a such type RV  $X$ .

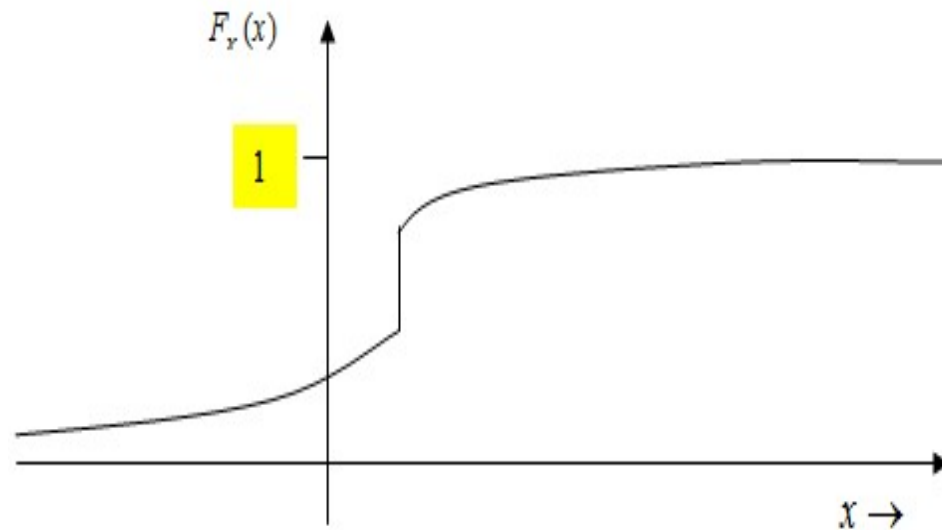

# **MODULE-II**

# **Distribution and Density Functions**

# Random Variable



## Review of the concepts

1. Random Experiment
2. Random Event
3. Outcomes
4. Sample Space
5. Random Variable:

Mapping of sample space to a real line

# Random Variable

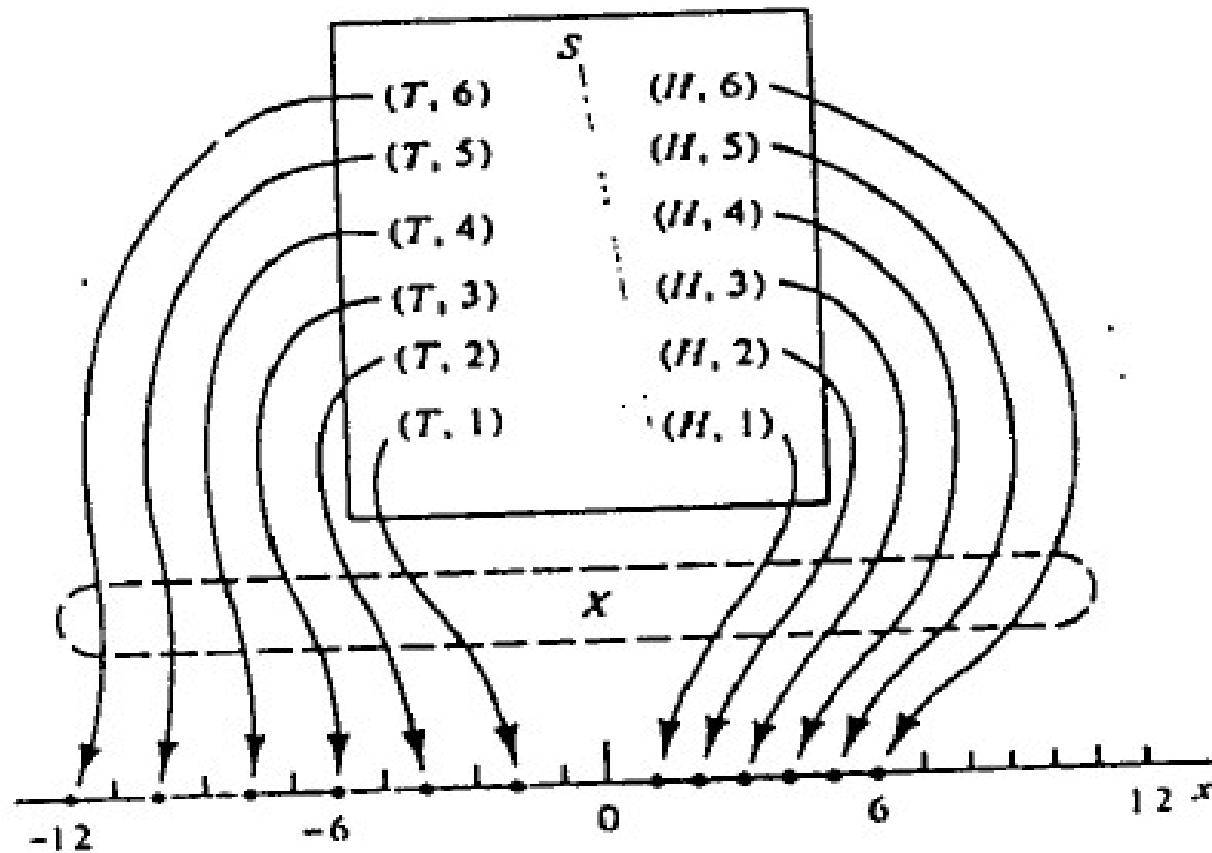

Mapping of sample space to a real line



# Distribution function



## Probability Distribution Function

The probability  $P(X \leq x)$  is the probability of the event  $\{X \leq x\}$ . i.e

$$F_x(x) = P\{X \leq x\}, \quad -\infty \leq x \leq \infty$$

# Properties of CDF



The properties of a distribution function:

- $F_x(-\infty) = 0$
- $F_x(\infty) = 1$
- $0 \leq F_x(x) \leq 1$
- $F_x(x_1) \leq F_x(x_2)$ , if  $x_1 < x_2$  (**Non-decreasing function**)
- $P\{x_1 < X < x_2\} = F_x(x_2) - F_x(x_1)$
- $F_x(x^+) = F_x(x)$  (**Continuous from the right**)

# Properties of CDF (contd..)



## Proof for $F_x(x_2) - F_x(x_1)$

- The events  $\{X \leq x_1\}$  and  $\{x_1 < X < x_2\}$  are mutually exclusive, i.e.  $\{X < x_2\} = \{X \leq x_1\} \cup \{x_1 < X < x_2\}$
- $P\{X < x_2\} = P\{X \leq x_1\} + P\{x_1 < X < x_2\}$
- $P\{x_1 < X < x_2\} = P\{X < x_2\} - P\{X \leq x_1\}$   
 $= F_x(x_2) - F_x(x_1)$

# Properties of CDF (contd..)



If  $X$  is a discrete random variable taking values  $x_i$ ,  $i = 1, 2, \dots, N$ , then  $F_x(x)$  must have a staircase function given by

$$\begin{aligned} F_x(x) &= \sum_{i=1}^N P\{X = x_i\} u(x - x_i) \\ &= \sum_{i=1}^N P(x_i) u(x - x_i) \end{aligned}$$

where  $u(\cdot)$  is the unit-step function defined by:

$$u(x) = \begin{cases} 1, & x \geq 0 \\ 0, & x < 0 \end{cases}$$

If  $N$  is infinite, then

$$P(x_i) = P\{X = x_i\}$$

# Probability density function



## Probability Density Function

The probability density function of the random variable  $X$  is defined as the derivative of the distribution function:

$$f_x(x) = \frac{dF_x(x)}{dx}$$

# Probability density function (contd..)



1. If the derivative of  $F_x(x)$  exists then  $f_x(x)$  exists
2. There may be places where  $\frac{dF_x(x)}{dx}$  is not defined at points of abrupt change, then we shall assume that the number of points where  $F_x(x)$  is not differentiable is countable.
3. For discrete random variables having a stair step form of distribution function.

$$f_x(x) = \sum_{i=1}^N P(x_1) \delta(x - x_1)$$

# Properties of PDF



## Properties of Density Functions.

- $0 \leq f_x(x)$  all  $x$
- $\int_{-\infty}^{\infty} f_x(x) dx = 1$
- $F_x(x) = \int_{-\infty}^x f_x(x) dx = 1$
- $P\{x_1 < X < x_2\} = \int_{x_1}^{x_2} f_x(x) dx$

# Gaussian Probability density function

## Gaussian Density Function

A random variable  $X$  is called Gaussian if its density function has the form

$$f_x(x) = \frac{1}{\sqrt{2\pi\sigma_x^2}} e^{-(x-a_x)^2/2\sigma_x^2}$$

Where  $\sigma_x > 0$  and  $-\infty < a_x < \infty$  are real constants.

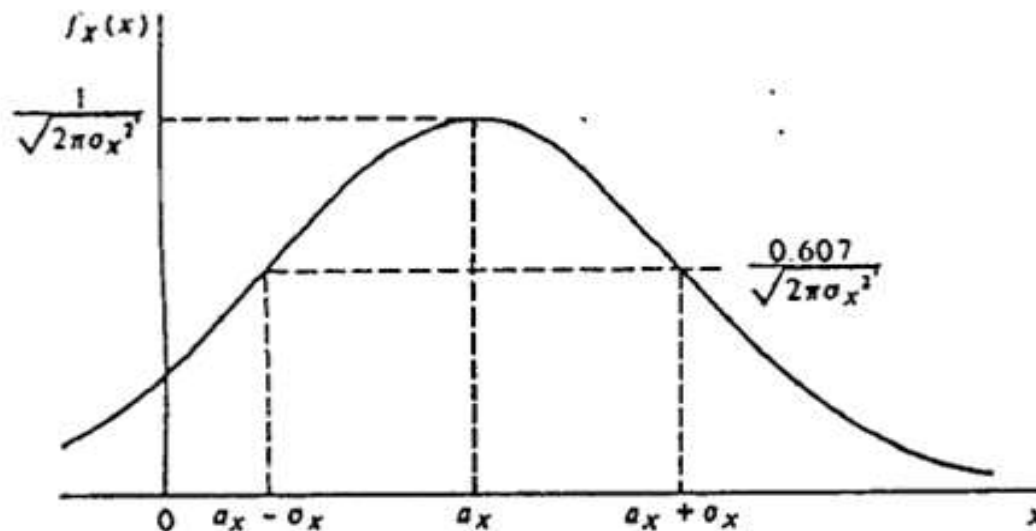



# Gaussian Probability density function (contd.)

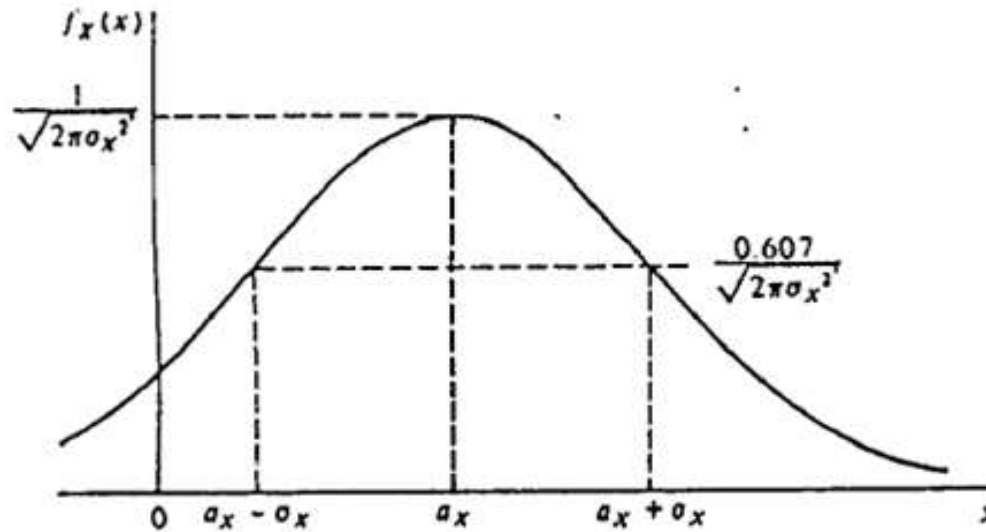

1. Its maximum value  $(2\pi\sigma_x^2)^{-\frac{1}{2}}$  occurs at  $x = a_x$ .
2. Its “spread” about the point  $x = a_x$  is related to  $\sigma_x$ .
3. The function decreases to 0.607 times its maximum at  $x = a_x + \sigma_x$  and  $x = a_x - \sigma_x$ .
4. The Gaussian density is the most important of all densities. It enters into nearly all areas of engineering

# Gaussian Probability density function (contd.)

$$F_x(x) = \frac{1}{\sqrt{2\pi\sigma_x^2}} \int_{-\infty}^x e^{-(\xi - \mu_x)^2 / 2\sigma_x^2} d\xi$$

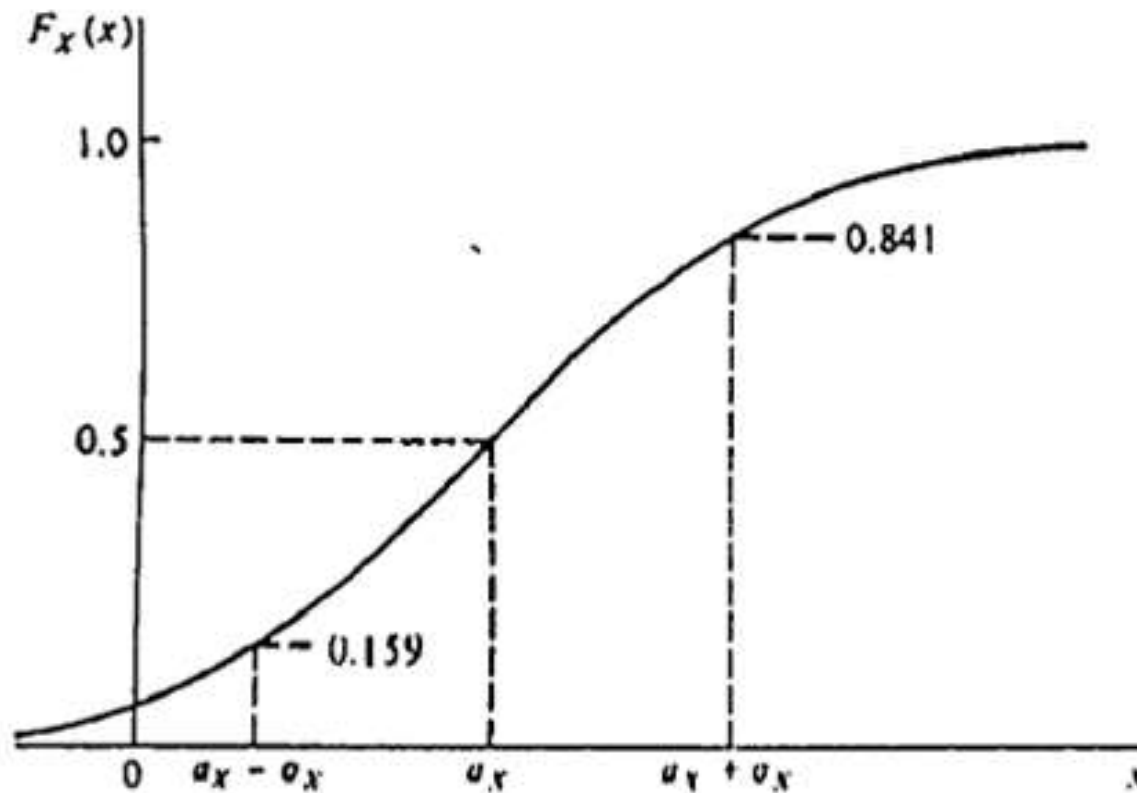

# Gaussian Probability density function (contd.)



- This integral has no known closed-form solution and must be evaluated by numerical methods.
- We could develop a set of tables of  $F_x(x)$  for various  $x$  and  $\alpha_x$  and  $\sigma_x$  as parameters (infinite number of tables).
- Only one table of  $F_x(x)$  for the normalized (specific) values  $\alpha_x = 0$  and  $\sigma_{x=1}$  given by

$$F(x) = \frac{1}{\sqrt{2\pi}} \int_{-\infty}^x e^{-\xi^2/2} d\xi$$

which is a function of  $x$  only & tabulated for  $x \geq 0$ .

- For negative values of  $x$  we have

$$F(-x) = 1 - F(x)$$

# Gaussian Probability density function (contd.)



- Making the variable change  $u = \frac{\xi - a_x}{\sigma_x}$ , we get

$$F_x(x) = \frac{1}{\sqrt{2\pi}} \int_{-\infty}^{(x-a_x)/\sigma_x} e^{-u^2/2} du = F\left(\frac{x - a_x}{\sigma_x}\right)$$

# Binomial Probability density function

## Binomial Density Function

$$f_x(x) = \sum_{k=0}^N \binom{N}{k} p^k (1-p)^{N-k} \delta(x-k)$$

where  $\binom{N}{k}$  is the binomial coefficient defined as

$$\binom{N}{k} = \frac{N!}{k!(N-k)!}$$

and  $0 < p < 1$ ,  $N = 1, 2, \dots$

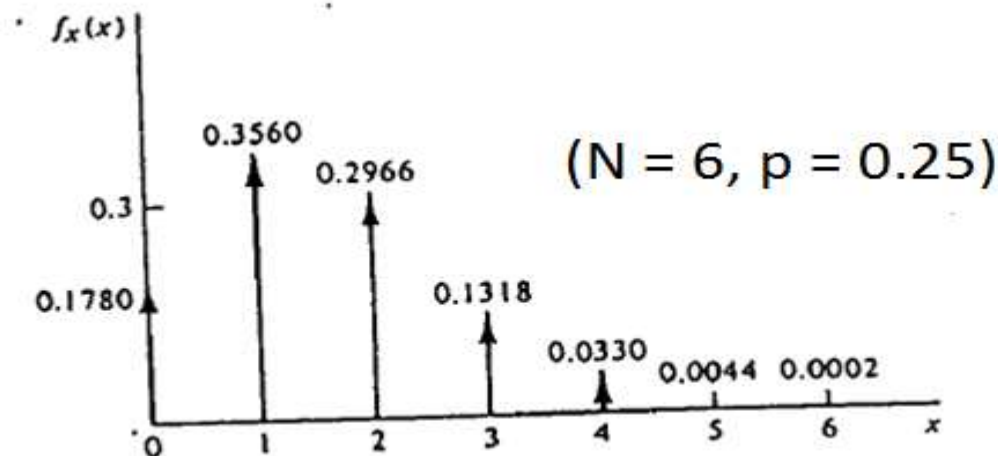

# Binomial Probability density function (contd)



1. The binomial density is applied to Bernoulli trial experiment, having only two possible outcomes on any given trial.
2. It applies to many games of chance, detection problems in radar and sonar, and many experiments

# Binomial Probability density function (contd.)



By integration, the binomial distribution function is found:

$$F_x(x) = \sum_{k=0}^N \binom{N}{k} p^k (1-p)^{N-k} \delta(x-k)$$

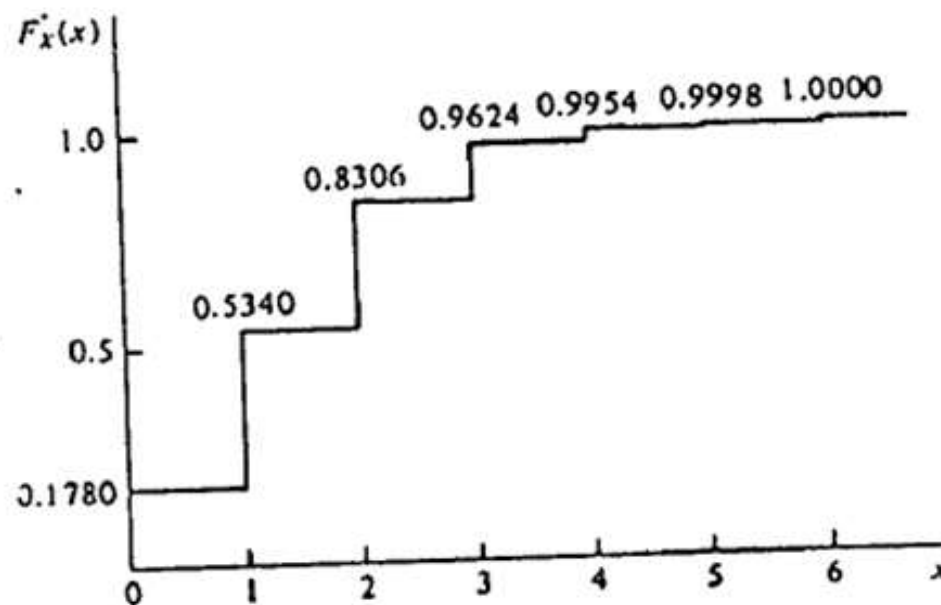

**Figure:** Binomial distribution function ( $N = 6$ ,  $p = 0.25$ )

# Poisson Probability density function



## Poisson Density Function

$$f_x(x) = e^{-b} \sum_{k=0}^{\infty} \frac{b^k}{k!} \delta(x - k)$$

$$F_x(x) = e^{-b} \sum_{k=0}^{\infty} \frac{b^k}{k!} u(x - k)$$

where  $b > 0$  is a real constant.

- These functions appear quite similar to binomial
- If  $N \rightarrow \infty$  and  $p \rightarrow 0$  for the binomial case in such a way that  $Np = b$ , a constant, the Poisson case results.
- The Poisson random variable applies to a wide variety of counting-type applications.



# Poisson Probability density function (contd)



- It describes
  - the number of defective units in a sample taken from a production line,
  - the number of telephone calls during a period of time,
  - the number of electrons emitted from a small section of a cathode in a given time interval, etc.
  - If the time interval of interest has duration  $T$ , and the events being counted are known to occur at an average rate  $\lambda$  and have a Poisson distribution, then  $b = \lambda T$

# Uniform Probability density function



## Uniform Density Function

$$f_x(x) = \begin{cases} \frac{1}{b-a}, & a \leq x \leq b \\ 0, & \text{elsewhere} \end{cases}$$

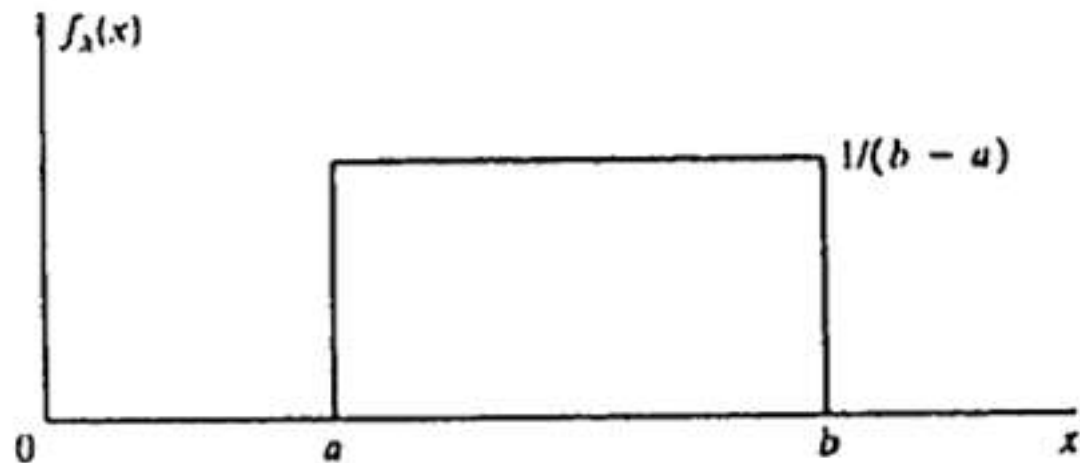

for real constants  $-\infty < a < \infty$  and  $b > a$ .

# Uniform Probability density function (contd)



$$F_x(x) = \begin{cases} 0, & x < a \\ \frac{x - a}{b - a}, & a \leq x \leq b \\ 1, & b \leq x \end{cases}$$

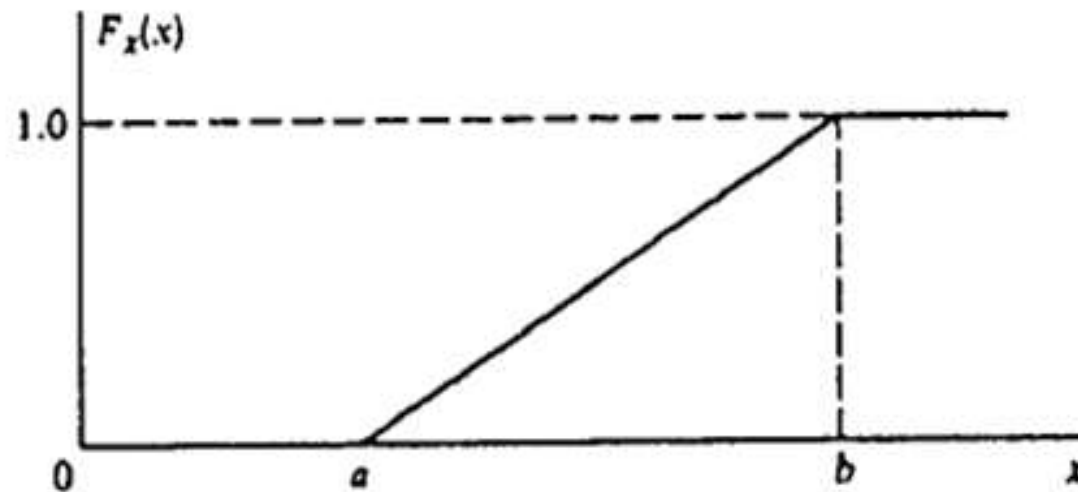

# Uniform Probability density function (contd)



- The error of quantization of signal samples prior to encoding in digital communication systems.
- Quantization amounts to “rounding off” the actual sample to the nearest of discrete quantum level.
- The quantization error introduced in the round-off process are uniformly distributed.

# Exponential Probability density function

## Exponential Density Function

$$f_x(x) = \begin{cases} \frac{1}{b} e^{-(x-a)/b} & x > a \\ 0, & x < a \end{cases}$$

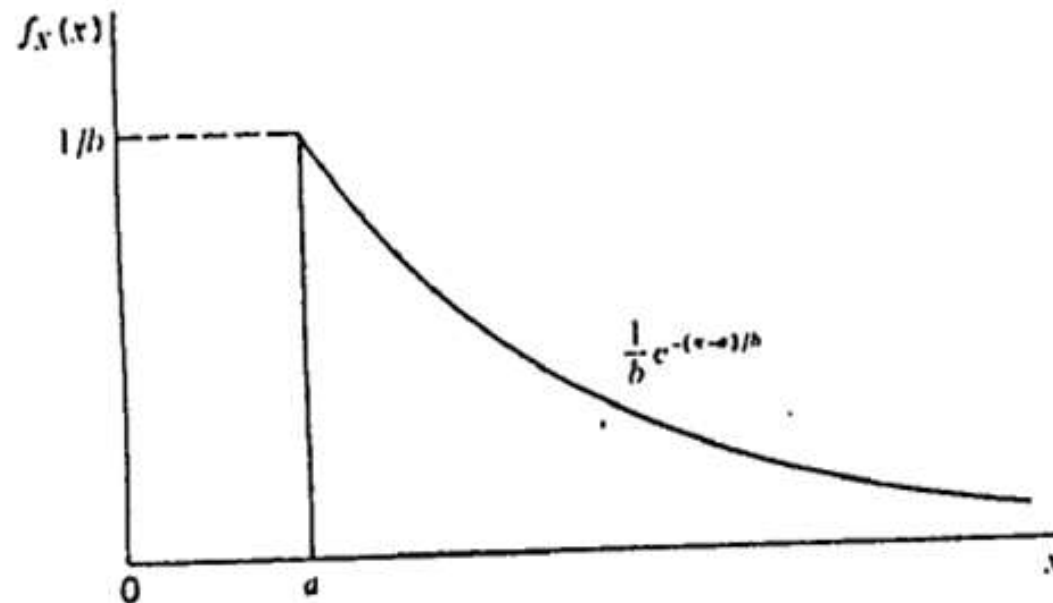

for real numbers  $-\infty < a < \infty$  and  $b > 0$

# Exponential Pdf (contd..)

$$F_x(x) = \begin{cases} 1 - e^{-(x-a)/b} & x > a \\ 0, & x < a \end{cases}$$

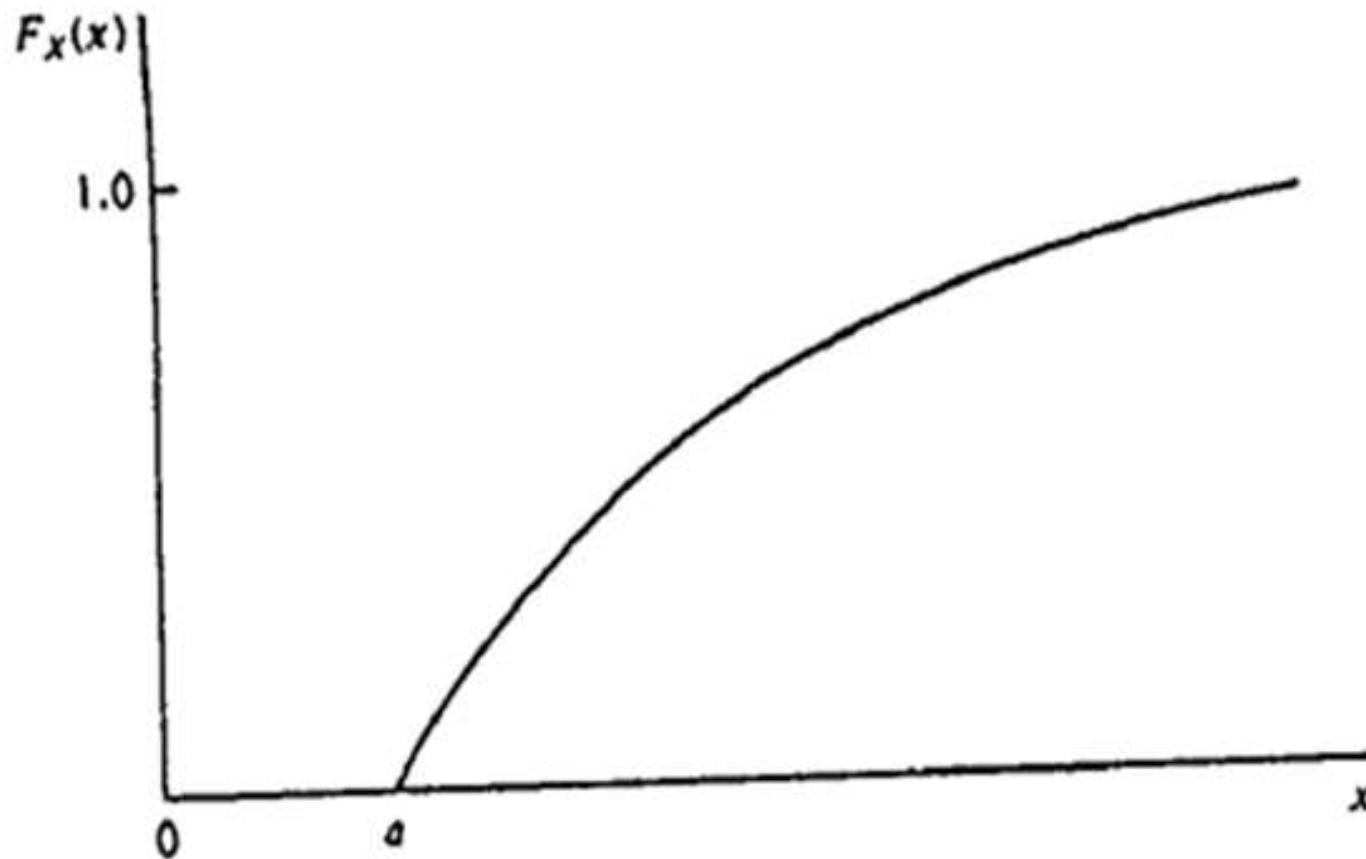

# Exponential Pdf (contd..)



- The exponential density is useful in describing raindrop sizes when a large number of rainstorm measurements are made.
- It is also known to approximately describe the fluctuations in signal strength received by radar from certain types of aircraft.

# Rayleigh Probability density function

## Rayleigh Density Function

$$f_x(x) = \begin{cases} \frac{2}{b}(x - a)e^{-(x-a)^2/b}, & x \geq a \\ 0, & x < a \end{cases}$$

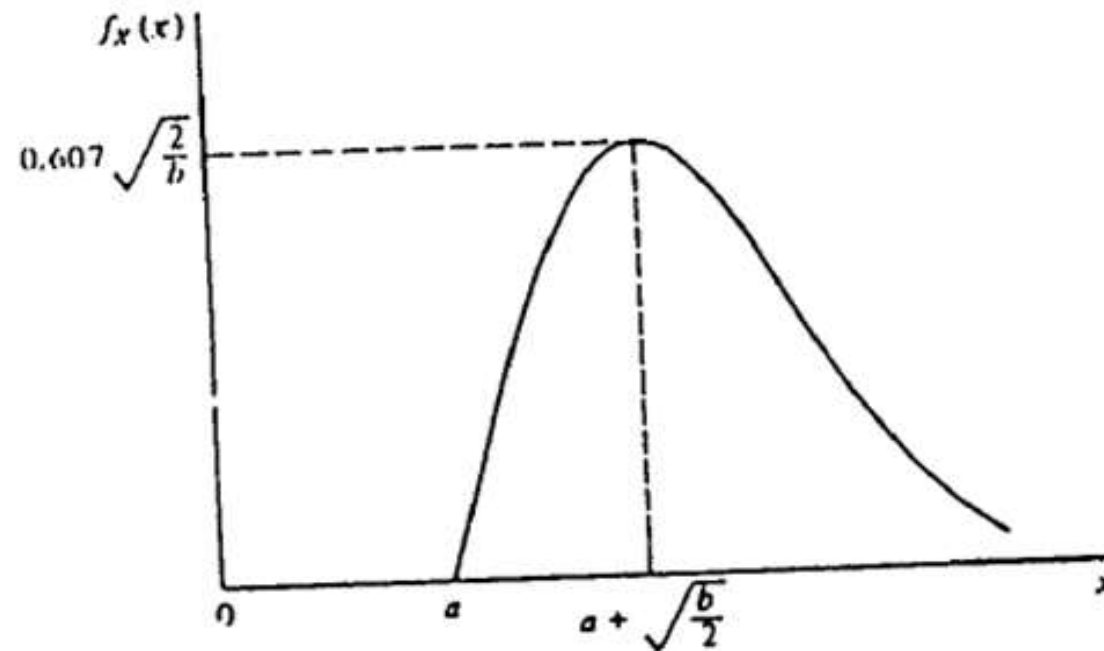

for the real constants  $-\infty < a < \infty$  and  $b > 0$



# Rayleigh Probability density function (contd)

$$F_x(x) = \begin{cases} 1 - e^{-(x-a)^2/b} & x \geq a \\ 0, & x < a \end{cases}$$

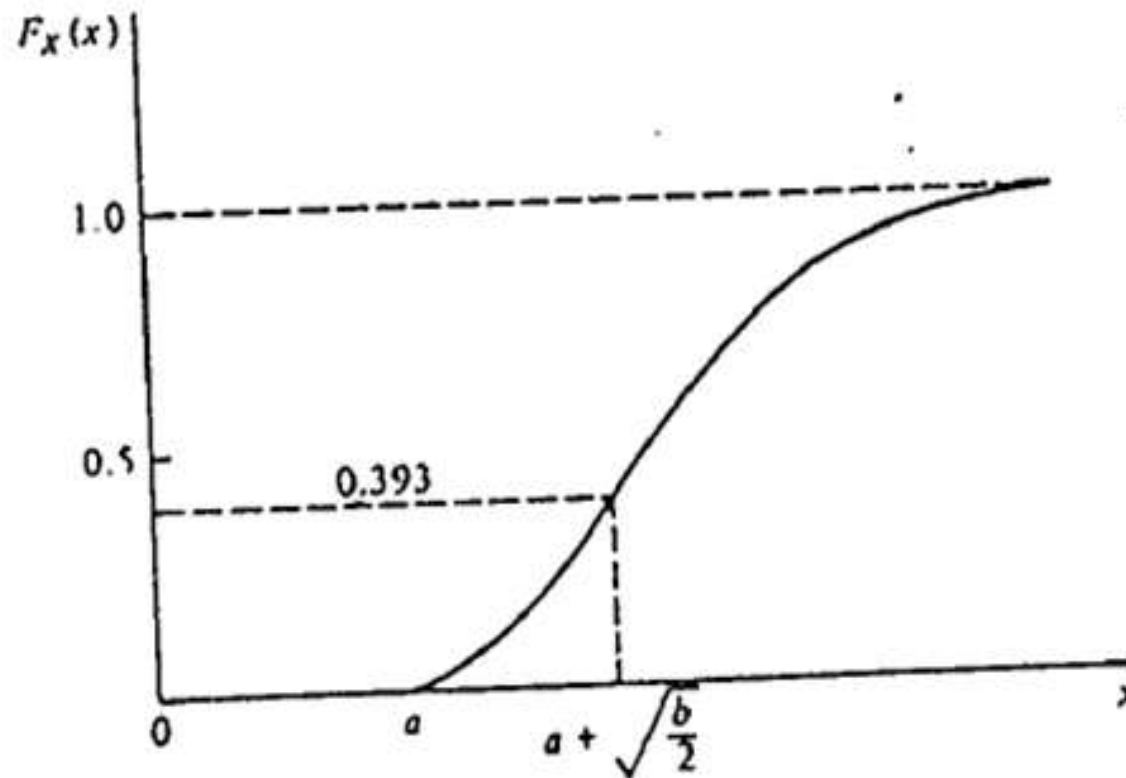

# Rayleigh Probability density function (contd)



- The Rayleigh density describes the envelope of white gaussian noise when passed through a band-pass filter.
- It is also is important in analysis of errors in various measurement systems.

# Conditional distribution function



## Conditional Distribution Function

- Let  $A$  and  $B$  be the two events &  $P(B) \neq 0$ , then

$$P(A|B) = \frac{P\{A \cap B\}}{P(B)}$$

- Let  $A$  be defined as the event  $\{X \leq x\}$  for the random variable  $X$ .
- The resulting probability  $P\{X \leq x|B\}$  is defined as the conditional distribution function of  $X$ , which is denoted by

$$F_x(x|B) = P\{X \leq x|B\} = \frac{P\{X \leq x \cap B\}}{P(B)}$$

where  $\{X \leq x \cap B\}$  is the joint event  $\{X \leq x\} \cap B$ . This joint event consists of all outcomes  $\mathbf{s}$  such that  $X(\mathbf{s}) \leq x$  and  $\mathbf{s} \in B$

# Properties of Conditional distribution function



## Properties of Conditional Distribution Function

- $F_x(-\infty|B) = 0$
- $F_x(\infty|B) = 1$
- $0 \leq F_x(x|B) \leq 1$
- $F_x(x_1|B) \leq F_x(x_2|B)$  if  $x_1 < x_2$
- $P\{x_1 < X \leq x_2|B\} = F_x(x_2|B) - F_x(x_1|B)$
- $F_x(x^+|B) = F_x(x|B)$

# Conditional density function



## Conditional Density Function

The conditional density function of the random variable  $X$  is defined as the derivative of the conditional distribution function, and is given by

$$f_x(x|B) = \frac{dF_x(x|B)}{dx}$$

If  $F_x(x|B)$  contains step discontinuities (when  $X$  is a discrete or mixed random variable), we assume that impulse functions are present in  $f_x(x|B)$  to account for the derivatives at the discontinuities.

## Properties of Conditional Density Function

- $f_x(x|B) \geq 0$
- $\int_{-\infty}^{\infty} f_x(x|B) dx = 1$
- $F_x(x|B) = \int_{-\infty}^x f_x(\xi|B) d\xi$
- $P\{x_1 < X < x_2|B\} = \int_{x_1}^{x_2} f_x(x|B) dx$

# Methods of conditioning event



## Methods of Defining Conditioning Event

If event  $B$  is defined in terms of the random variable  $X$  as  $B = \{X \leq b\}$ , where  $b$  is some real number  $-\infty < b < \infty$  &  $P\{X \leq b\} \neq 0$ , then we have

$$\begin{aligned} F_x(x|B) &= P\{X \leq x|B\} \\ &= P\{X \leq x|X \leq b\} \\ &= \frac{P\{X \leq x \cap X \leq b\}}{P\{X \leq b\}} \end{aligned}$$

# Methods of conditioning event (contd..)



## Case (i):

If  $b \leq x$ , then the event  $\{X \leq b\}$  is an subset of the event  $\{X \leq x\}$ , so  $\{X \leq x\} \cap \{X \leq b\} = \{X \leq b\}$ . Then we have

$$\begin{aligned} F_x(x|X \leq b) &= \frac{P\{X \leq x \cap X \leq b\}}{P\{X \leq b\}} \\ &= \frac{P\{X \leq b\}}{P\{X \leq b\}} = 1 \quad x \geq b \end{aligned}$$



# Methods of conditioning event (contd..)



## Case (ii):

$$\begin{aligned} F_x(x|X \leq b) &= \frac{P\{X \leq x \cap X \leq b\}}{P\{X \leq b\}} \\ &= \frac{P\{X \leq x\}}{P\{X \leq b\}} = \frac{F_x(x)}{F_x(b)} \quad x < b \end{aligned}$$

# Methods of conditioning event (contd..)



By combining the last two expressions, we have

$$F_x(x|X \leq b) = \begin{cases} \frac{F_x(x)}{F_x(b)} & x < b \\ 1, & x \geq b \end{cases}$$

From our assumption that the conditioning event has nonzero probability,  $0 < F_x(b) \leq 1$ , so the conditional distribution function is never smaller than the ordinary distribution function  $F_x(x|X \leq b) \geq F_x(x)$

# Methods of conditioning event (contd..)



Similarly the conditional density function is

$$f_x(x|X \leq b) = \begin{cases} \frac{f_x(x)}{F_x(x)} = \frac{f_x(x)}{\int_{-\infty}^b f_x(x)dx} & x < b \\ 0, & x \geq b \end{cases}$$

From our assumption  $0 < f_x(x) \leq 1$ , so the conditional density function is never smaller than the ordinary density function

$$f_x(x|X \leq b) \geq f_x(x) \quad x < b$$

The result can be extended to more general event

$$B = \{a < X \leq b\}$$

# Moments about origin



## Moments About the Origin

The expected value of  $X^n$ ,  $n = 0, 1, 2, \dots$  is given by

$$E[X^n] = \int_{-\infty}^{\infty} x^n f_x(x) dx$$

gives the moments about the origin of the random variable  $X$ . These are also called standard moments and are denoted as  $m_n$

# Moments about mean



## Moments About the Mean

The expected value of  $(X - \bar{X})^n$ ,  $n = 0, 1, 2, \dots$  is given by

$$E[(X - \bar{X})^n] = \int_{-\infty}^{\infty} (x - \bar{X})^n f_x(x) dx$$

gives the moments about the mean of the random variable  $X$ . These are also called central moments and are denoted as  $\mu_n$

# Characteristic function



## Characteristic Function

The *characteristic function* of a random variable  $X$  is defined by

$$\Phi_x(\omega) = E[e^{j\omega x}] = \int_{-\infty}^{\infty} e^{j\omega x} f_x(x) dx$$

where  $j = \sqrt{-1}$ . It is a function of the real number  $-\infty < \omega < \infty$ .

$\Phi_x(\omega)$  is seen as the *Fourier transform* (with the sign of  $\omega$  reversed) of  $f_x(x)$

# Moment generating function



## Moment Generating Function

The *moment generating function* of a random variable  $X$  is defined by

$$M_x(v) = E[e^{vx}] = \int_{-\infty}^{\infty} f_x(x)e^{vx} dx$$

Where  $v$  is a real number  $-\infty < v < \infty$ .

# Moment generating function



- Moments are related to  $M_x(v)$  by the expression

$$m_x = (-j)^n \frac{d^n M_x(v)}{dv^n} \Big|_{v=0}$$

- The main disadvantage of the moment generating function is that it may not exist for all random variables.
- In fact,  $M_x(v)$  exists only if all the moments exist



# Monotonically increasing RV



## Transformations of A Random Variable

- Quite often one may wish to transform one random variable  $X$  into a new random variable  $Y$  by means of a transformation

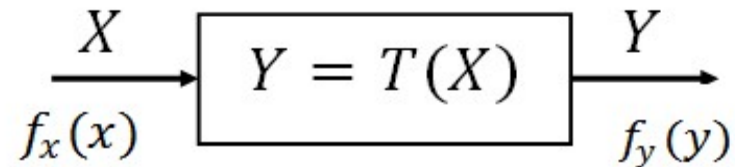

- Typically, the density function  $f_x(x)$  or distribution function  $F_x(x)$  of  $X$  is known, and the problem is to determine either the density function  $f_y(y)$  or distribution function  $F_y(y)$  of  $Y$ .
- The transformation  $T$  can be linear, nonlinear, segmented, staircase, etc

# Monotonically increasing RV (contd..)

## Monotonic Transformation of a Continuous Random variable

- A transformation  $T$  is called *monotonically increasing* if  $T(x_1) < T(x_2)$  for any  $x_1 < x_2$ .

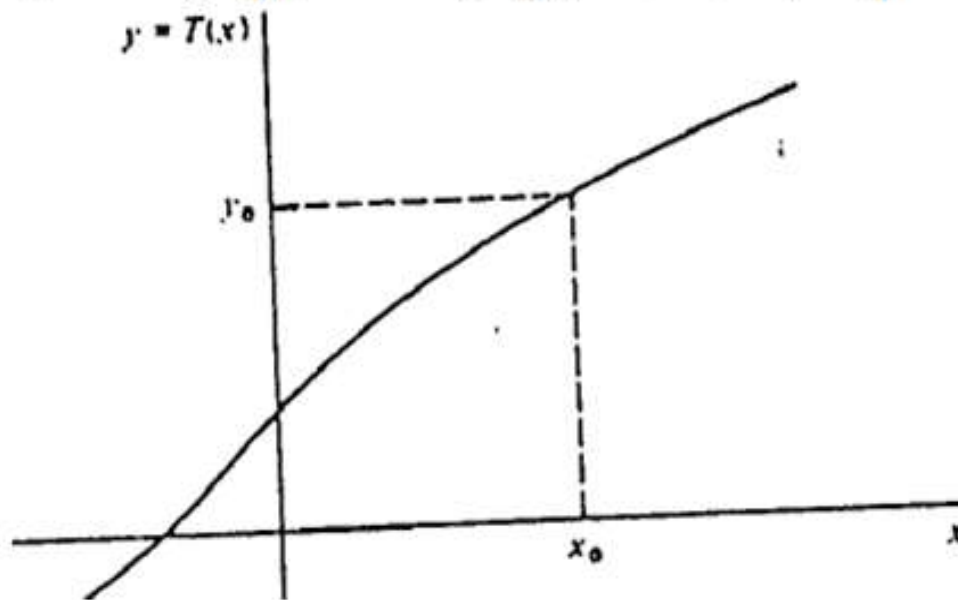

# Nonmonotonic Transformation of a RV

## Nonmonotonic transformations of a continuous random variable

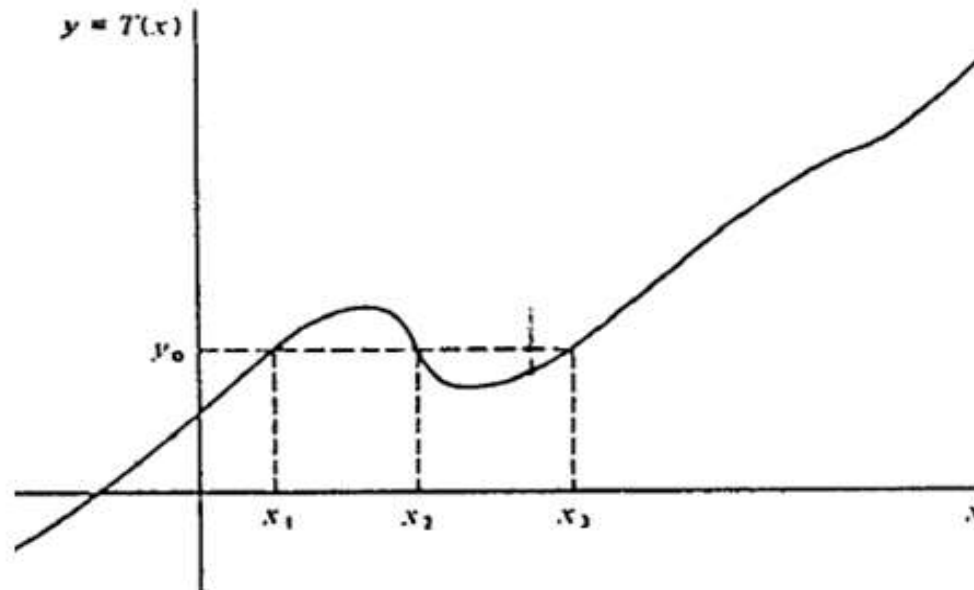

- In this case, there may be more than one interval of values of  $X$  that correspond to the event  $\{Y \leq y_0\}$  corresponds to the event  $\{X \leq x_1 \text{ and } x_2 \leq X \leq x_3\}$

# Nonmonotonic Transformation of a RV (contd.)



- Thus, the probability of the event  $\{Y \leq y_0\}$  now equals the probability of the event  $\{x \text{ values yielding } Y \leq y_0\}$ , which we shall write as  $\{x|Y \leq y_0\}$  i.e.,

$$F_y(y_0) = p\{Y \leq y_0\} = p\{x|Y \leq y_0\} = \int_{\{x|Y \leq y_0\}} f_x(x) dx$$

- Differentiating we get the density function of  $Y$  as

$$f_y(y_0) = \frac{d}{dy_0} \int_{\{x|Y \leq y_0\}} f_x(x) dx$$

# Nonmonotonic Transformation of a RV (contd.)



- The density function is also given by

$$f_y(y) = \sum_n \frac{f_x(x_n)}{\left| \frac{dT(x)}{dx} \right|_{x=x_n}}$$

where the sum is taken so as to include all the roots  $x_n, n = 1, 2, \dots$ , which are the real solutions of the equation

$$y = T(x)$$

# Transformation of a DiscreteRV



## Transformation of a Discrete Random Variable

- If  $X$  is a discrete random variable

$$f_x(x) = \sum_n p(x_n) \delta(x - x_n)$$
$$F_x(x) = \sum_n p(x_n) u(x - x_n)$$

where the sum is taken to include all the possible values  $x_n, n = 1, 2, \dots, \dots$ , of  $X$ .

- If the transformation  $Y = T(X)$  is continuous and monotonic, there is a one-to-one correspondence between  $X$  and  $Y$  so that a set  $\{x_n\}$ , through the equation  $y_n = T\{x_n\}$  so that  $P\{y_n\} = P\{x_n\}$ .

# Transformation of a DiscreteRV (contd..)



- If the transformation  $Y = T(X)$  is continuous and monotonic, there is a one-to-one correspondence between  $X$  and  $Y$  so that a set  $\{x_n\}$ , through the equation  $y_n = T\{x_n\}$  so that  $P\{y_n\} = P\{x_n\}$ .
- Thus, we have

$$f_y(y) = \sum_n p(y_n) \delta(y - y_n)$$

$$F_y(y) = \sum_n p(y_n) u(y - y_n) \text{ where } y_n = T(x_n)$$

- If  $T$  is not monotonic, the above procedure remains same, but  $P(y_n)$  will equal the sum of the probabilities of the various  $x_n$  for which  $y_n = T(x_n)$

# Expected value of a RV



## Expected Value of a Random variable

In general, the expected value of any random variable  $X$  is defined by

$$E[X] = \bar{X} = \int_{-\infty}^{\infty} x f_x(x) dx$$



# Expected value of a RV (contd..)



If  $X$  is discrete with  $N$  possible values  $x_i$  having probabilities  $P(x_i)$  of occurrence, then

$$f_x(x) = \sum_{i=1}^N x_i P(x_i) \delta(x - x_i)$$

Then we have

$$E[x] = \sum_{i=1}^N x_i P(x_i)$$

If the density is symmetrical about a line  $x = a$  i.e.

$$f_x(x + a) = f_x(-x + a)$$

then

$$E[x] = a$$

# Conditional Expected value of a RV



## Conditional Expected Value

If  $f_x(x|B)$  is the conditional density where  $B$  is any event defined on the sample space of  $X$ , then the *conditional expected value* of  $X$ , is given by

$$E[X|B] = \int_{-\infty}^{\infty} x f_x(x|B) dx$$

# Conditional Expected value of a RV (contd.)



If the event  $B = \{X \leq b\}$ ,  $-\infty < b < \infty$

$$f_x(x|X \leq b) = \begin{cases} \frac{f_x(x)}{\int_{-\infty}^b f_x(x)dx} & x < b \\ 0 & x \geq b \end{cases}$$

Then, the conditional expected value is given by

$$E[x|X \leq b] = \frac{\int_{-\infty}^b x f_x(x)dx}{\int_{-\infty}^b f_x(x)dx}$$

which is the mean value of  $X$  when  $X$  is constrained to the set  $\{X \leq b\}$ .

# Moments about origin



## Moments About the Origin

The expected value of  $X^n$ ,  $n = 0, 1, 2, \dots$  is given by

$$E[X^n] = \int_{-\infty}^{\infty} x^n f_x(x) dx$$

gives the moments about the origin of the random variable  $X$ . These are also called standard moments and are denoted as  $m_n$

# Moments about origin (contd..)



For  $n = 0$ ,

$$m_0 = E[X^0] = \int_{-\infty}^{\infty} x^0 f_x(x) dx = \int_{-\infty}^{\infty} f_x(x) dx$$

is the area of under the function  $f_x(x)$ .

For  $n = 1$ ,

$$m_1 = E[X] = \int_{-\infty}^{\infty} x f_x(x) dx = \bar{X}$$

is the expected value of  $X$ .

# Moments about mean



## Moments About the Mean

The expected value of  $(X - \bar{X})^n$ ,  $n = 0, 1, 2, \dots$  is given by

$$E[(X - \bar{X})^n] = \int_{-\infty}^{\infty} (x - \bar{X})^n f_x(x) dx$$

gives the moments about the mean of the random variable  $X$ . These are also called central moments and are denoted as  $\mu_n$

# Moments about mean (contd..)



For  $n = 0$ ,

$$\mu_n = E[(X - \bar{X})^n] = \int_{-\infty}^{\infty} (x - \bar{X})^n f_x(x) dx$$

$$\mu_0 = E[(X - \bar{X})^0] = \int_{-\infty}^{\infty} f_x(x) dx$$

is the area of under the function  $f_x(x)$ .

For  $n = 1$ ,

$$\mu_1 = E[(X - \bar{X})] = E[X] - \bar{X} = 0$$

# Variance



## Variance

The second central moment  $\mu_2$  is given by

$$\mu_2 = E[(X - \bar{X})^2] = \int_{-\infty}^{\infty} (X - \bar{X})^2 f_x(x) dx$$

1. It is popularly known as the *variance*  $\sigma_x^2$  of the random variable  $X$ .
2. The positive square root  $\sigma_x$  of variance is called the standard deviation of  $X$ .
3. It is a measure of the spread in the function  $f_x(x)$  about the mean.



# Variance (contd..)



The second central moment is given by

$$\mu_2 = E[(X - \bar{X})^2]$$

By expanding we get

$$\begin{aligned}\mu_2 &= E[X^2 - 2\bar{X}X + \bar{X}^2] \\ &= E[X^2] - 2\bar{X}E[X] + \bar{X}^2 \\ &= E[X^2] - \bar{X}^2 = m_2 - \mu_1^2\end{aligned}$$

## Skew

The third central moment is given by

$$\begin{aligned}\mu_3 &= E[(X - \bar{X})^3] \\ \mu_3 &= E[X^3 - 3X^2\bar{X} + 3X\bar{X}^2 - \bar{X}^3] \\ &= E[X^3] - 3E[X^2]\bar{X} + 3\bar{X}^2E[X] - \bar{X}^3 \\ &= m_3 - 3m_2\mu_1 + 3\mu_1^3 - \mu_1^3 \\ &= m_3 - 3m_2\mu_1 + 2\mu_1^3\end{aligned}$$

# Skew (contd..)



- $\mu_3$  is a measure of asymmetry of  $f_x(x)$  about the mean.
- It will be called the *skew* of the density function.
- If a density is symmetric about  $x = \bar{X}$ , it has zero skew. For this case,  $\mu_n = 0$  for all odd values of  $n$ .
- The normalized third central moment  $\mu_3/\sigma_x^3$  is known as the coefficient of *skewness*.

# **MODULE-III**

## **Multiple Random Variables and Operations**

# Vector random variables

- There are many cases where the outcome is a vector of numbers. We have already seen one such experiment, in, where a dart is thrown at random on a dartboard of radius  $r$ . The outcome is a pair  $(X, Y)$  of random variables that are such that  $X^2 + Y^2 \leq r^2$ .
- we measure voltage and current in an electric circuit with known resistance. Owing to random fluctuations and measurement error, we can view this as an outcome  $(V, I)$  of a pair of random variables.
- Mapping the sample space to joint sample space

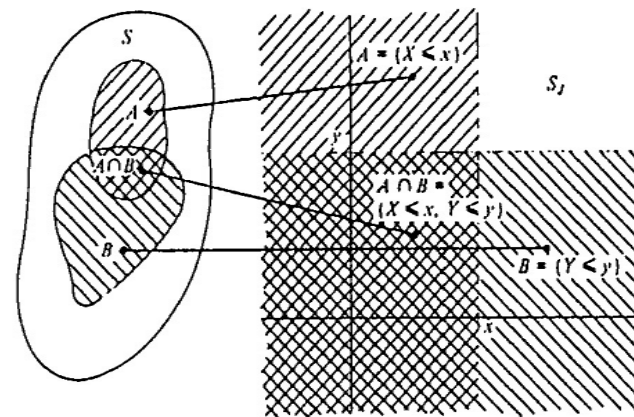
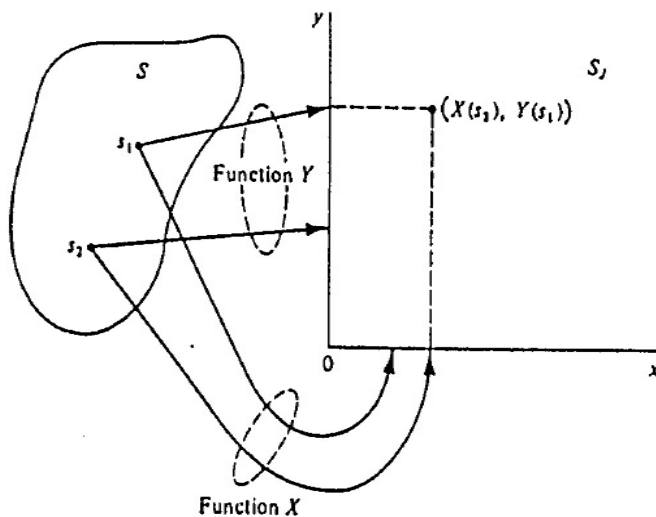

Comparison of sample space  $s$  with  $s_j$

# Joint distribution function



- Let  $X$  and  $Y$  be random variables. The pair  $(X, Y)$  is then called a (two-dimensional) random vector.
- The joint distribution function (joint cdf) of  $(X, Y)$  is defined as  $F(x, y) = P(X \leq x, Y \leq y)$  for  $x, y \in \mathbb{R}$ .
- Assume the joint sample space  $S_j$  has only three possible elements  $(1,1), (2,1), (3,3)$ . The probabilities of the elements are to be  $P(1,1)=0.2, P(2,1)=0.3, P(3,3)=0.5$ . We find  $F_{X,Y}(X,Y)$
- In constructing joint distribution function we observe that has no elements for  $x < 1, y < 1$ . only at the point  $(1,1)$  does the function assume a step value.
- So long as  $x \geq 1, y \geq 1$  this probability is maintained. For larger  $x$  and  $y$  the point  $(2,1)$  produces a second stair step of 0.3 which holds the region  $x \geq 2, y \geq 1$ . The second step is added to the first. Finally third step of 0.5 is added to the two for  $x \geq 3, y \geq 3$

# Properties of Joint Distribution



- Properties:

1)  $F_{X,Y}(-\infty, y) = F_{X,Y}(x, -\infty) = 0$

Note that  $\{X \leq -\infty, Y \leq y\} \subseteq \{X \leq -\infty\}$

2)  $F_{X,Y}(x_1, y_1) \leq F_{X,Y}(x_2, y_2)$  if  $x_1 \leq x_2$  and  $y_1 \leq y_2$

If  $x_1 < x_2$  and  $y_1 < y_2$ ,

$$\{X \leq x_1, Y \leq y_1\} \subseteq \{X \leq x_2, Y \leq y_2\}$$

$$\therefore P\{X \leq x_1, Y \leq y_1\} \leq P\{X \leq x_2, Y \leq y_2\}$$

$$\therefore F_{X,Y}(x_1, y_1) \leq F_{X,Y}(x_2, y_2)$$

3)  $F_{X,Y}(\infty, \infty) = 1$

4)  $F_{X,Y}(x, y)$  is right continuous in both the variables

$$F_X(x) = F_{XY}(x, +\infty)$$

# Properties of joint distribution



5) If  $x_1 < x_2$  and  $y_1 < y_2$

$$P(\{x_1 < X \leq x_2, y_1 < Y \leq y_2\}) = F_{X,Y}(x_2, y_2) - F_{X,Y}(x_1, y_2) - F_{X,Y}(x_2, y_1) + F_{X,Y}(x_1, y_1)$$
$$F_{X,Y}(x, y), \quad -\infty < x < \infty, -\infty < y < \infty$$

6)

$$F_X(x) = F_{XY}(x, +\infty)$$

$$\{X \leq x\} = \{X \leq x\} \cap \{Y \leq +\infty\}$$

$$\therefore F_X(x) = P(\{X \leq x\}) = P(\{X \leq x, Y \leq \infty\}) = F_{X,Y}(x, +\infty)$$

$$F_Y(y) = F_{XY}(\infty, y)$$

$$F_{X,Y}(x, y), \quad -\infty < x < \infty, -\infty < y < \infty$$

$F_X(x)$  and  $F_Y(y)$     Called marginal cumulative distribution function



# Marginal distribution functions



- The distribution of one random variable can be obtained by setting the other value to infinity in  $F_{X,Y}(x,y)$ . The functions obtained in this manner  $F_X(x), F_Y(y)$  are called marginal distribution functions.

- Example:

$$F_{X,Y}(x,y) = P(1,1)u(x-1)u(y-1) + P(2,1)u(x-2)u(y-1) + P(3,3)u(x-3)u(y-3)$$

$P(1,1)=0.2, P(2,1)=0.3, P(3,3)=0.5$  if we set  $y=\infty$  then

$$F_X(x) = 0.2u(x-1) + 0.3u(x-2) + 0.5u(x-3)$$

similarly

$$\begin{aligned} F_Y(y) &= 0.2u(y-1) + 0.3u(y-1) + 0.5u(y-3) \\ &= 0.5u(y-1) + 0.5u(y-3) \end{aligned}$$

# Marginal distribution functions



- Consider two jointly distributed random variables  $X$  and  $Y$  with the joint CDF

$$F_{X,Y}(x, y) = \begin{cases} (1 - e^{-2x})(1 - e^{-y}) & x \geq 0, y \geq 0 \\ 0 & \text{otherwise} \end{cases}$$

- 1) Find the marginal CDFs
- 2) Find the probability  $P(1 < X \leq 2, 1 < Y \leq 2)$

# Marginal distribution functions



$$a) \quad F_X(x) = \lim_{y \rightarrow \infty} F_{X,Y}(x, y) = \begin{cases} 1 - e^{-2x} & x \geq 0 \\ 0 & \text{elsewhere} \end{cases}$$

$$F_Y(y) = \lim_{x \rightarrow \infty} F_{X,Y}(x, y) = \begin{cases} 1 - e^{-y} & y \geq 0 \\ 0 & \text{elsewhere} \end{cases}$$

$$\begin{aligned} P\{1 < X \leq 2, 1 < Y \leq 2\} &= F_{X,Y}(2,2) + F_{X,Y}(1,1) - F_{X,Y}(1,2) - F_{X,Y}(2,1) \\ &= (1 - e^{-4})(1 - e^{-2}) + (1 - e^{-2})(1 - e^{-1}) - (1 - e^{-2})(1 - e^{-2}) - (1 - e^{-4})(1 - e^{-1}) \\ &= 0.0272 \end{aligned}$$

# Joint Probability Density Function



- If  $X$  and  $Y$  are two continuous random variables and their joint distribution function is continuous in both  $x$  and  $y$  then we can define joint probability density function by

$$f_{X,Y}(x,y) = \frac{\partial^2}{\partial x \partial y} F_{X,Y}(x,y),$$

provided it exists.

Clearly

$$F_{X,Y}(x,y) = \int_{-\infty}^x \int_{-\infty}^y f_{X,Y}(u,v) dv du$$

# Marginal density function



- The marginal CDF and pdf are same as the CDF and pdf of the concerned single random variable. The marginal term simply refers that it is derived from the corresponding joint distribution or density function of two or more jointly random variables.
- With the help of the two-dimensional Dirac Delta function, we can define the joint pdf of two discrete jointly random variables. Thus for discrete jointly random variables and

$$f_{X,Y}(x,y) = \sum_{(x_i,y_j) \in R_X \times R_Y} \sum p_{X,Y}(x,y) \delta(x-x_i, y-y_j)$$

# Marginal density function



- The joint density function

$$F_{X,Y}(x, y) = \begin{cases} (1 - e^{-2x})(1 - e^{-y}) & x \geq 0, y \geq 0 \\ 0 & \text{otherwise} \end{cases}$$

$$\begin{aligned} f_{X,Y}(x, y) &= \frac{\partial^2}{\partial x \partial y} F_{X,Y}(x, y) \\ &= \frac{\partial^2}{\partial x \partial y} [(1 - e^{-2x})(1 - e^{-y})] \quad x \geq 0, y \geq 0 \\ &= 2e^{-2x}e^{-y} \quad x \geq 0, y \geq 0 \end{aligned}$$

# Conditional distribution



- We discussed the conditional CDF and conditional PDF of a random variable conditioned on some events defined in terms of the same random variable. We observed that

$$F_X(x|B) = \frac{P(\{X \leq x\} \cap B)}{P(B)} \quad P(B) \neq 0$$

$$f_X(x|B) = \frac{d}{dx} F_X(x|B)$$

# Conditional density function



- Suppose  $X$  and  $Y$  are two discrete jointly random variable with the joint PMF  $f_{XY}(x,y)$ . The conditional PMF of  $Y$  given  $X=x$  is denoted by  $f_{Y/X}(y/x)$  and defined as

$$f_{Y/X}(y/x)$$

$$\begin{aligned} P_{Y/X}(y/x) &= P(\{Y = y\} | \{X = x\}) \\ &= \frac{P(\{X = x\} \cap \{Y = y\})}{P\{X = x\}} \\ &= \frac{P_{X,Y}(x,y)}{P_X(x)} \quad \text{provided } P_X(x) \neq 0 \end{aligned}$$

Thus,

$$P_{Y/X}(y/x) = \frac{P_{X,Y}(x,y)}{P_X(x)} \quad \text{provided } P_X(x) \neq 0$$



# Conditional Probability Distribution Function



- Consider two continuous jointly random variables and with the joint probability distribution function We are interested to find the conditional distribution function of one of the random variables on the condition of a particular value of the other random variable.
- We cannot define the conditional distribution function of the random variable on the condition of the event by the relation

$$\begin{aligned} F_{Y/X}(y/x) &= P(Y \leq y / X = x) \\ &= \frac{P(Y \leq y, X = x)}{P(X = x)} \end{aligned}$$

# Point conditioning



- First consider the case when  $X$  and  $Y$  are both discrete. Then the marginal pdf's
- $f_Y(y)=P(Y=y)$        $f_X(x)=P(X=x)$
- The joint pdf is, similarly  
 $f_{X,Y}(x,y)=P(X\leq x,Y\leq y)$
- Conditional density function is given by  
 $f_X(x/B)=\frac{dFX(x|B)}{dx}$

# Point conditioning (contd..)



- The conditional pdf of the conditional distribution  $Y|X$  is

$$f_{Y|X}(y|x) = P(Y \leq y | X = x) \\ = \frac{P(Y \leq y, X = x)}{P(X = x)}$$

- Distribution function of one random variable  $X$  conditioned by that second variable  $Y$  has some specific values of  $y$ . This is called point conditioning
- $B = \{y - \Delta y < Y \leq y + \Delta y\}$   
Where  $\Delta y$  is a small quantity that we eventually let approach 0.

# Point conditioning (contd..)



$$F_X(x / y - \Delta y < Y \leq y + \Delta y) = \frac{\int_{y - \Delta y}^{y + \Delta y} \int_{-\infty}^x f_{X,Y}(\xi_1, \xi_2) d\xi_1 d\xi_2}{\int_{y - \Delta y}^{y + \Delta y} f_Y(\xi) d\xi}$$

$$F_{X,Y}(x, y) = \sum_{i=1}^N \sum_{j=1}^M P(x_i, y_j) \delta(x - x_i) \delta(y - y_j)$$

Now the specific value of  $y$  of interest is  $y_k$

$$F_X(x / Y = y_k) = \sum_{i=1}^N \frac{P(x_i, y_k)}{P(y_k)} u(x - x_i)$$

$$f_X(x / Y = y_k) = \sum_{i=1}^N \frac{P(x_i, y_k)}{P(y_k)} \delta(x - x_i)$$

# Interval Conditioning

- Distribution function of one random variable  $X$  conditioned by that second variable  $Y$  has some specific values of  $y$ . This is called point conditioning  $B = \{y_a < Y \leq y_b\}$
- $P(x_1, y_1) = 2/15, P(x_2, y_1) = 3/15$ . etc. since  $P(y_3) = 4/15 + 5/15 = 9/15$  find  $f_x(x/y=y_3)$

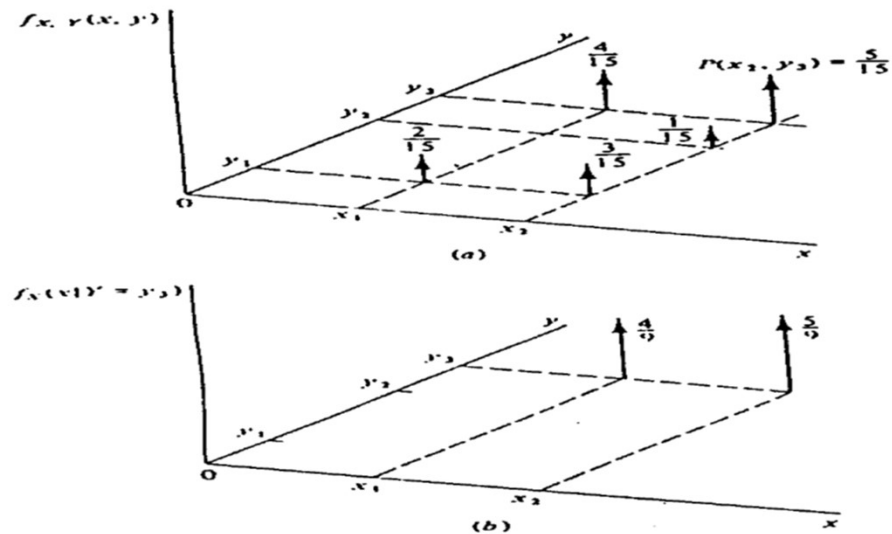

# Statistical independence



- Let  $X$  and  $Y$  be two random variables characterized by the joint distribution function

$$F_{X,Y}(x,y) = P\{X \leq x, Y \leq y\}$$

and the corresponding joint density function

$$f_{X,Y}(x,y) = \frac{\partial^2}{\partial x \partial y} F_{X,Y}(x,y)$$

# Sum of two random variables

- We are often interested in finding out the probability density function of a function of two or more RVs
- The received signal by a communication receiver is given by

$$Z = X + Y$$

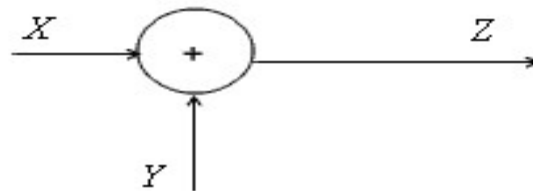

- where  $Z$  is received signal which is the superposition of the message signal and the noise.

# Sum of two random variables

corresponding to each  $z$ .  $\{Z \leq z\}$  We can find a variable subset  $D_z = \{(x, y) \mid g(x, y) \leq z\}$

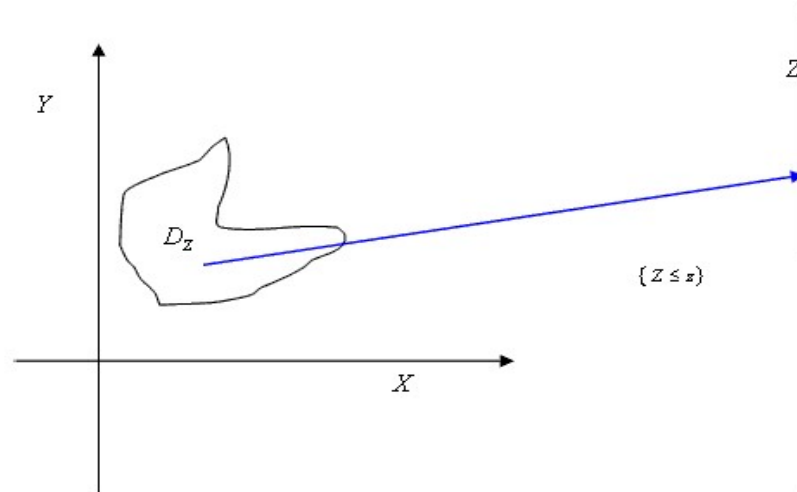

$$\begin{aligned} \therefore F_Z(z) &= P(\{Z \leq z\}) \\ &= P\{(x, y) \mid (x, y) \in D_z\} \\ &= \iint_{(x, y) \in D_z} f_{X, Y}(x, y) \, dy \, dx \end{aligned}$$



# Central Limit Theorem



- Consider  $n$  **independent** random variables  $x_1, x_2, x_3, \dots, x_n$ , The mean and variance of each of the random variables are assumed to be known. Suppose  $E[x] = \mu_x$   $\text{var}(x) = \sigma_x^2$  and . Form a random variable

$$Y_N = X_1 + X_2 + \dots + X_N$$

The mean and variance of  $Y_N$  are given by

$$E[y_n] = \mu_{x_1} + \mu_{x_2} + \mu_{x_3} + \dots + \mu_{x_n}$$

$$\begin{aligned} \text{var}(Y_n) &= \sigma_{Y_n}^2 = E\left\{\sum_{i=1}^n (X_i - \mu_{X_i})\right\}^2 \\ &= \sum_{i=1}^n E(X_i - \mu_{X_i})^2 + \sum_{i=1}^n \sum_{j=1, j \neq i}^n E(X_i - \mu_i)(X_j - \mu_j) \\ &= \sigma_{X_1}^2 + \sigma_{X_2}^2 + \dots + \sigma_{X_n}^2 \\ &\quad \because X_i \text{ and } X_j \text{ are independent for } i \neq j. \end{aligned}$$

# Central Limit Theorem (contd..)



The CLT states that under very general conditions  $\left\{ Y_n = \sum_{i=1}^n X_i \right\}$  converges in distribution to  $Y \sim N(\mu_Y, \sigma_Y^2)$  as  $n \rightarrow \infty$

1. The random variables are independent and identically distributed.
2. The random variables are independent with same mean and variance, but not identically distributed.
3. The random variables are independent with different means and same variance and not identically distributed.
4. The random variables are independent with different means and each variance being neither too small nor too large.

# Expected Values of Random Variables

- If  $g(x,y)$  is a function of a continuous random variables  $X$  and  $Y$  then then the expected value of is given by

$$\bar{g} = E[g(X,Y)] = \begin{cases} \int_{-\infty}^{\infty} \int_{-\infty}^{\infty} g(x,y) f_{X,Y}(x,y) dx dy & \text{Continuous} \\ \sum_i \sum_k g(x_i, y_k) P_{X,Y}(x_i, y_k) & \text{Discrete} \end{cases}$$

# Example

- Consider the discrete random variables  $x$  and  $y$ . The joint probability mass function of the random variables are tabulated in Table . Find the joint expectation of  $g(x,y)=xy$ .

$\begin{matrix} X \\ Y \end{matrix}$	0	1	2	$p_Y(y)$
0	0.25	0.1	0.15	0.5
1	0.14	0.35	0.01	0.5
$p_X(x)$	0.39	0.45	0.16	

$$\begin{aligned}
 E[XY] &= \sum_x \sum_y g(x, y) p_{XY}(x, y) \\
 &= 1 \times 1 \times 0.35 + 1 \times 2 \times 0.01 \\
 &= 0.37
 \end{aligned}$$

# Properties



- Expectation is a linear operator. We can generally write  
 $E[a_1g_1(x,y)+a_2g_2(x,y)]=a_1E(g_1(x,y))+a_2E(g_2(x,y))$   
 $E[xy+5\log_e xy]=E[xy]+5E[\log_e xy]$
- If  $x$  and  $y$  are independent random variables and  
 $g(x,y)=g_1(x,y)\times g_2(x,y)$  then  $E[g(x,y)]=E[g_1(x,y)]\times E[g_2(x,y)]$

$$\begin{aligned}Eg(X, Y) &= Eg_1(X)g_2(Y) \\ &= \int_{-\infty}^{\infty} \int_{-\infty}^{\infty} g_1(X)g_2(Y)f_{X,Y}(x,y)dx \\ &= \int_{-\infty}^{\infty} \int_{-\infty}^{\infty} g_1(X)g_2(Y)f_X(x)f_Y(y)dx dy \\ &= \int_{-\infty}^{\infty} g_1(X)f_X(x)dx \int_{-\infty}^{\infty} g_2(Y)f_Y(y)dy \\ &= Eg_1(X)Eg_2(Y)\end{aligned}$$

# Joint moments about the origin



For two continuous random variables  $X$  and  $Y$ , the joint moment of order  $m+n$  is defined as

$$E(X^m Y^n) = \int_{-\infty}^{\infty} \int_{-\infty}^{\infty} x^m y^n f_{XY}(x, y) dx dy$$

And the joint central moment of order  $m+n$  is defined as

$$E(X - \mu_x)^m E(Y - \mu_y)^n = \int_{-\infty}^{\infty} \int_{-\infty}^{\infty} (x - \mu_x)^m (y - \mu_y)^n f_{XY}(x, y) dx dy$$

$$\mu_x = E[x]$$

$$\mu_y = E[y]$$

# Covariance of two random variables

The covariance of two random variables  $X$  and  $Y$  is defined as

$$\text{Cov}(X, Y) = E(X - \mu_x)(Y - \mu_y)$$

$\text{Cov}(X, Y)$  is also denoted as  $\sigma_{XY}$ .

$$\begin{aligned} \text{Cov}(X, Y) &= E(X - \mu_x)(Y - \mu_y) \\ &= E(XY - \mu_y X - \mu_x Y + \mu_x \mu_y) \\ &= E(XY) - \mu_y E(X) - \mu_x E(Y) + \mu_x \mu_y \\ &= E(XY) - \mu_x \mu_y \end{aligned}$$

# Uncorrelated random variables



Two random variables are called *uncorrelated* if

$$\text{Cov}(X,Y)=0$$

Which also means  $E(XY)=\mu_x\mu_y$

If are independent random variables, then

$$f_{XY}(x,y)=f_X(x)f_Y(y)$$

Thus two independent random variables are always uncorrelated.



# joint characteristic function



The joint characteristic function of two random variables  $X$  and  $Y$  is defined by

$$\phi_{XY}(\omega_1, \omega_2) = E[e^{j\omega_1 x + j\omega_2 y}]$$

If  $X$  and  $Y$  are jointly continuous random variables, then

$$\phi_{X,Y}(\omega_1, \omega_2) = \int_{-\infty}^{\infty} \int_{-\infty}^{\infty} f_{XY}(x, y) e^{j\omega_1 x + j\omega_2 y} dx dy$$

# Joint moments about the origin



For two discrete random variables  $X$  and  $Y$ , the joint moment of order  $m+n$  is defined as

$$E(X^m Y^n) = \sum_x \sum_y x^m y^n f_{XY}(x, y) dx dy$$

And the joint central moment of order  $m+n$  is defined as

$$E(X - \mu_x)^m E(Y - \mu_y)^n = \sum_x \sum_y (x - \mu_x)^m (y - \mu_y)^n f_{XY}(x, y)$$

$$\mu_x = E[x]$$

$$\mu_y = E[y]$$

# Covariance of two random variables



The covariance of two random variables  $X$  and  $Y$  is defined as

$$\text{Cov}(X,Y)=E(X-\mu_x)E(Y-\mu_y)$$

$\text{Cov}(X, Y)$  is also denoted as  $\sigma_{XY}$ .

$$\begin{aligned}\text{Cov}(X, Y) &= E(X - \mu_x)^m E(Y - \mu_y)^n \\ &= E(XY - \mu_y X - \mu_x Y + \mu_x \mu_y) \\ &= E(XY) - \mu_y E(X) - \mu_x E(Y) + \mu_x \mu_y \\ &= E(XY) - \mu_x \mu_y\end{aligned}$$

# Two Random variables



Two random variables  $X$  and  $Y$  are called jointly Gaussian if their joint probability density

$$f_{X,Y}(x,y) = \frac{1}{2\pi\sigma_x\sigma_y\sqrt{1-\rho_{XY}^2}} e^{-\frac{1}{2(1-\rho_{XY}^2)} \left[ \frac{(x-\mu_x)^2}{\sigma_x^2} - 2\rho_{XY} \frac{(x-\mu_x)(y-\mu_y)}{\sigma_x\sigma_y} + \frac{(y-\mu_y)^2}{\sigma_y^2} \right]}$$

$-\infty < x < \infty, -\infty < y < \infty$

means  $\mu_x$  and  $\mu_y$

variances  $\sigma_x^2$   $\sigma_y^2$

correlation coefficient  $\rho_{XY}$

We denote the jointly Gaussian random variables and

with these parameters as  $(X,Y) \sim N(\mu_x, \mu_y, \sigma_x^2, \sigma_y^2, \rho_{XY})$

# Transformations of multiple random variables



The joint density function of new random variable  $Y_i = T(X_1, X_2, \dots, X_N)$   
 $i = 1, 2, 3, \dots, n$

The random variable  $X_j$  can be obtained from inverse transformation

$$X_j = T_j^{-1}(Y_1, Y_2, \dots, Y_N)$$

$$\left. \begin{array}{l} x_1 = g_1^{-1}(y_1, y_2, \dots, y_k) \\ x_2 = g_2^{-1}(y_1, y_2, \dots, y_k) \\ \vdots \\ x_n = g_n^{-1}(y_1, y_2, \dots, y_{k=n}) \end{array} \right\} **$$

# Transformations of multiple random variables



- Assuming that the partial derivatives  $\partial g_i^{-1} / \partial y_i$  exist at every point  $(y_1, y_2, \dots, y_{k=n})$ . Under these assumptions, we have the following determinant J

$$J = \det \begin{bmatrix} \frac{\partial g_1^{-1}}{\partial y_1} & \dots & \frac{\partial g_1^{-1}}{\partial y_n} \\ \vdots & \ddots & \vdots \\ \frac{\partial g_n^{-1}}{\partial y_1} & \dots & \frac{\partial g_n^{-1}}{\partial y_n} \end{bmatrix}$$

called as the Jacobian of the transformation specified by (\*\*). Then, the joint pdf of  $Y_1, Y_2, \dots, Y_k$  can be obtained by using the change of variable technique of multiple variables.

# Transformations of multiple random variables



- As a result, the new p.d.f. is defined as follows:

$$g(y_1, y_2, \dots, y_n) = \begin{cases} f_{X_1, \dots, X_n}(g_1^{-1}, g_2^{-1}, \dots, g_n^{-1}) |J|, & \text{for } (y_1, y_2, \dots, y_n) \in \Psi \\ 0, & \text{otherwise} \end{cases}$$

# Linearly transformation of Gaussian RV



- Linearly transforming set of Gaussian random variables  $X_1, X_2, \dots, X_N$  for which the joint density function exists. The new variables  $Y_1, Y_2, \dots, Y_N$  are
- $Y_1 = a_{11}X_1 + a_{12}X_2 + \dots + a_{1N}X_N$
- $Y_2 = a_{21}X_1 + a_{22}X_2 + \dots + a_{2N}X_N$ .
- $Y_N = a_{N1}X_1 + a_{N2}X_2 + \dots + a_{NN}X_N$

$$[T] = \begin{bmatrix} a_{11} & a_{12} \dots & a_{1N} \\ a_{21} & a_{22} \dots & a_{2N} \\ a_{N1} & a_{N2} \dots & a_{NN} \end{bmatrix}$$

$$[Y] = \begin{bmatrix} Y_1 \\ \vdots \\ Y_N \end{bmatrix}$$

$$X_i = T_i^{-1}(Y_1, \dots, Y_N) = a^{i1}Y_1 + a^{i2}Y_2 + \dots + a^{iN}Y_N$$

$$[Y] = [T][X]$$



# **MODULE-IV**

## **Stochastic Processes: Temporal Characteristics**

# Random Process

□ The concept of random variable was defined previously as mapping from the **Sample Space S** to the real line as shown below

□ A random process is a process (i.e., variation in time or one dimensional space) whose behavior is not completely predictable and can be characterized by statistical laws.

□ Examples of random processes

Daily stream flow

Hourly rainfall of storm events

Stock index

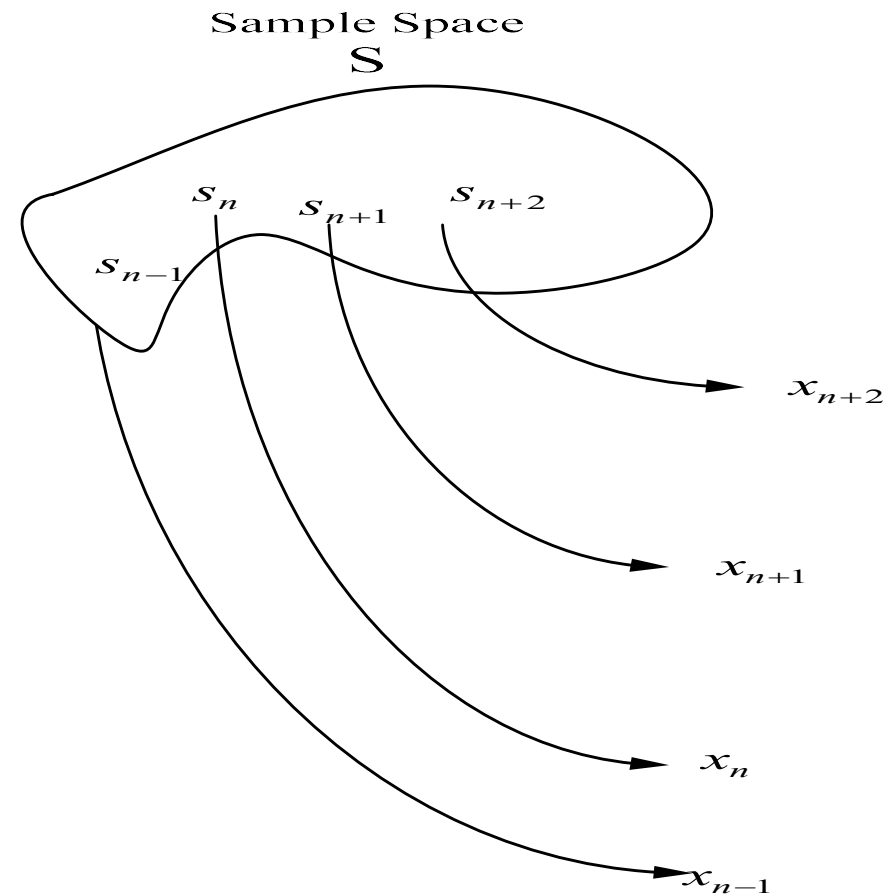

# Random Process (Contd..)

□ The concept of random process can be extended to include time and the outcome will be random functions of time as shown beside  $x(t, s)$

□ Where  $s$  is the outcome of an experiment

□ The functions

$\cdots x_{n+2}(t), x_{n+1}(t), x_n(t), x_{n-1}(t), \cdots$   
are one realizations of many of the random process  $X(t)$

□ A random process also represents a random variable when time is fixed  
 $X(t_1)$  is a random variable

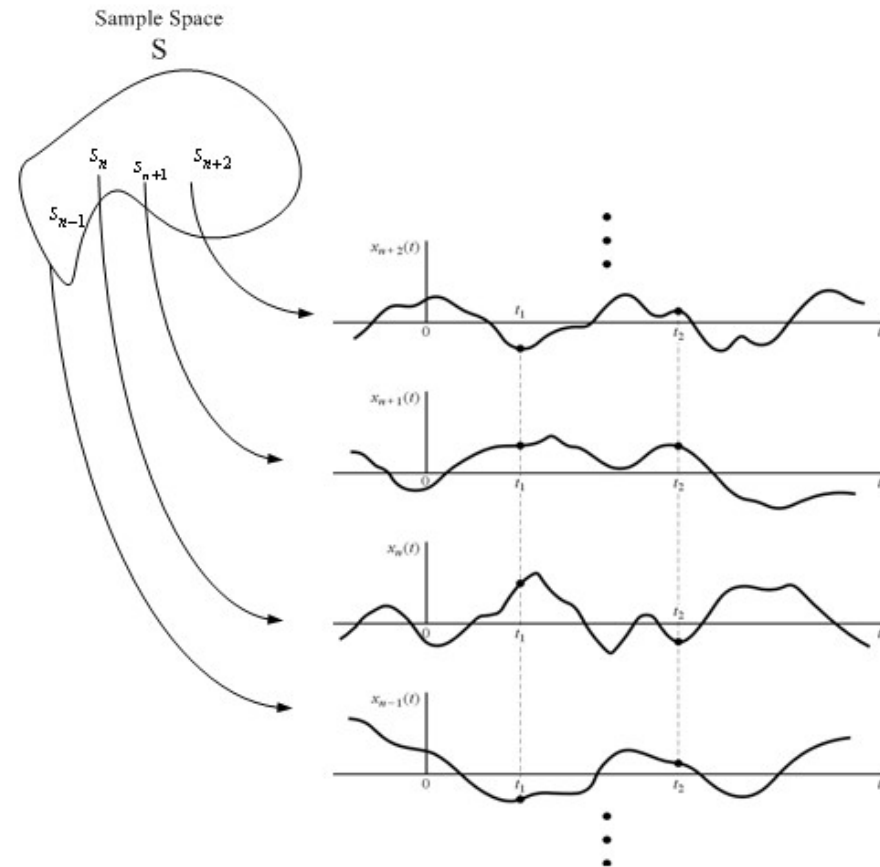

# Classification of Random Process



- ❑ Classification of random process

  - ❑ Continuous random process

  - ❑ Discrete random process

  - ❑ Continuous random sequence

  - ❑ Discrete random sequence

Continuous time  $t \Rightarrow x(t) = \text{Random process}$

Discrete time  $n \Rightarrow x[n] = \text{Random sequence}$

# Continuous Random Process

□ Continuous random process

Continuous time  $t$

$x(t)$  = Continuous  
Random process

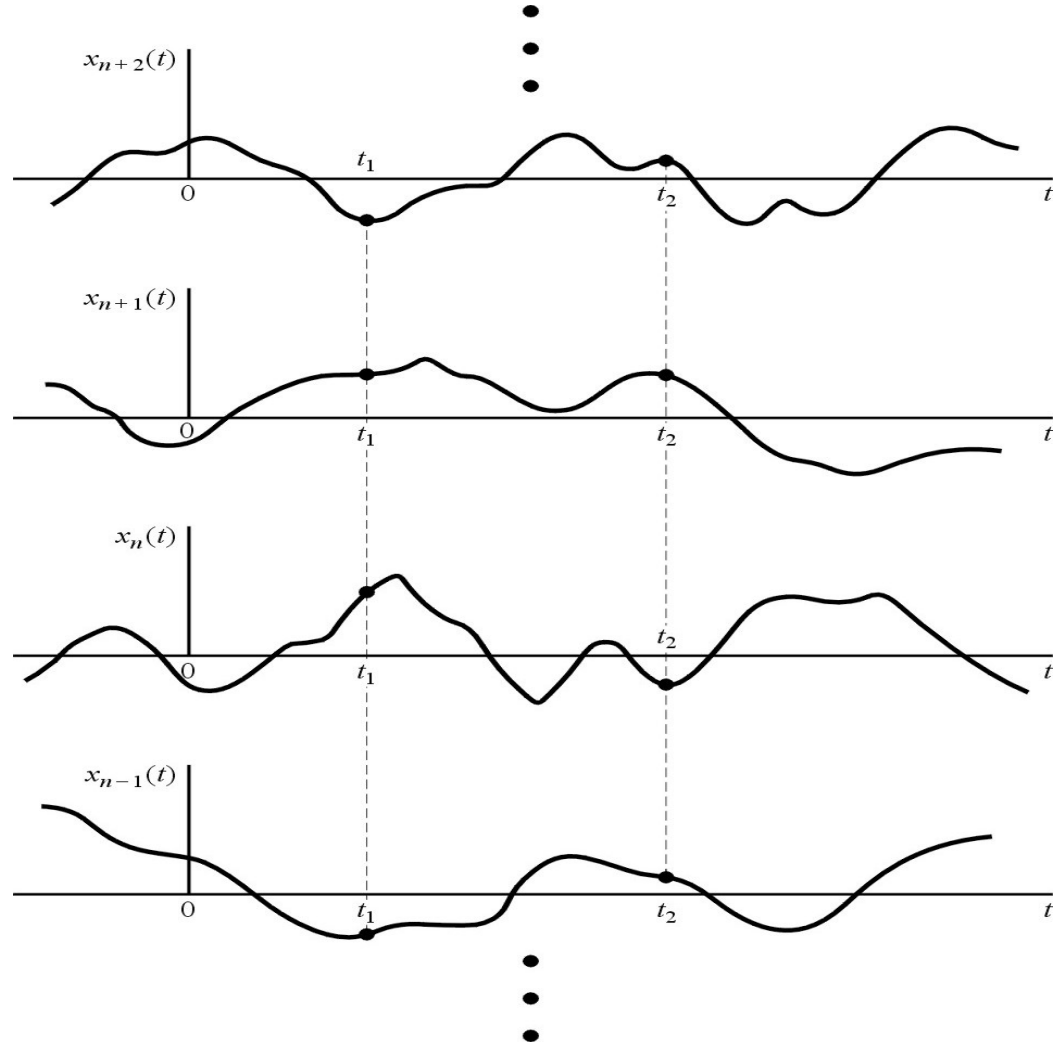

# Discrete Random Process

□ Discrete random process

Continuous time  $t$

$x(t) =$  Discrete Random process

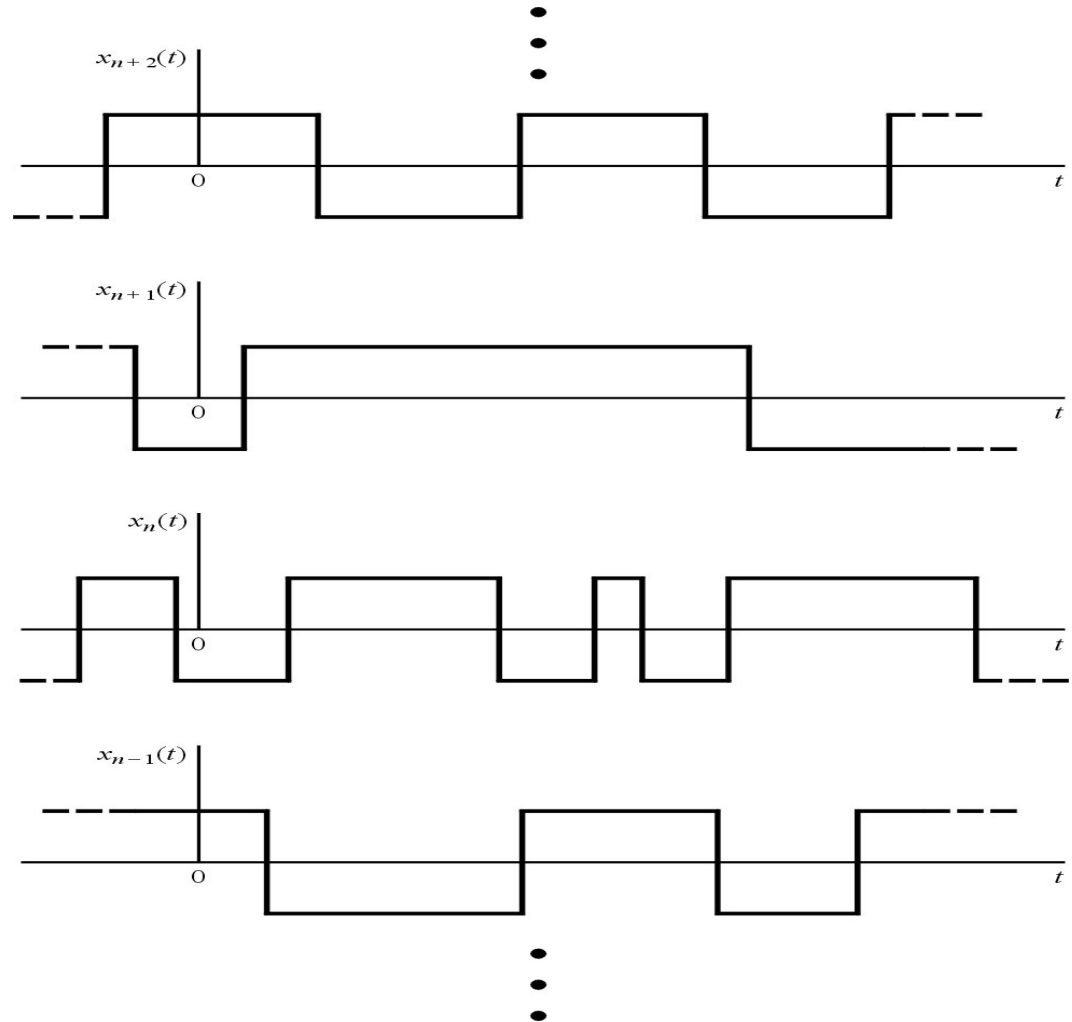

# Continuous Random Sequence

## □ Continuous random sequence

discrete time  $n$

$x(n) =$  Continuous  
Random sequence

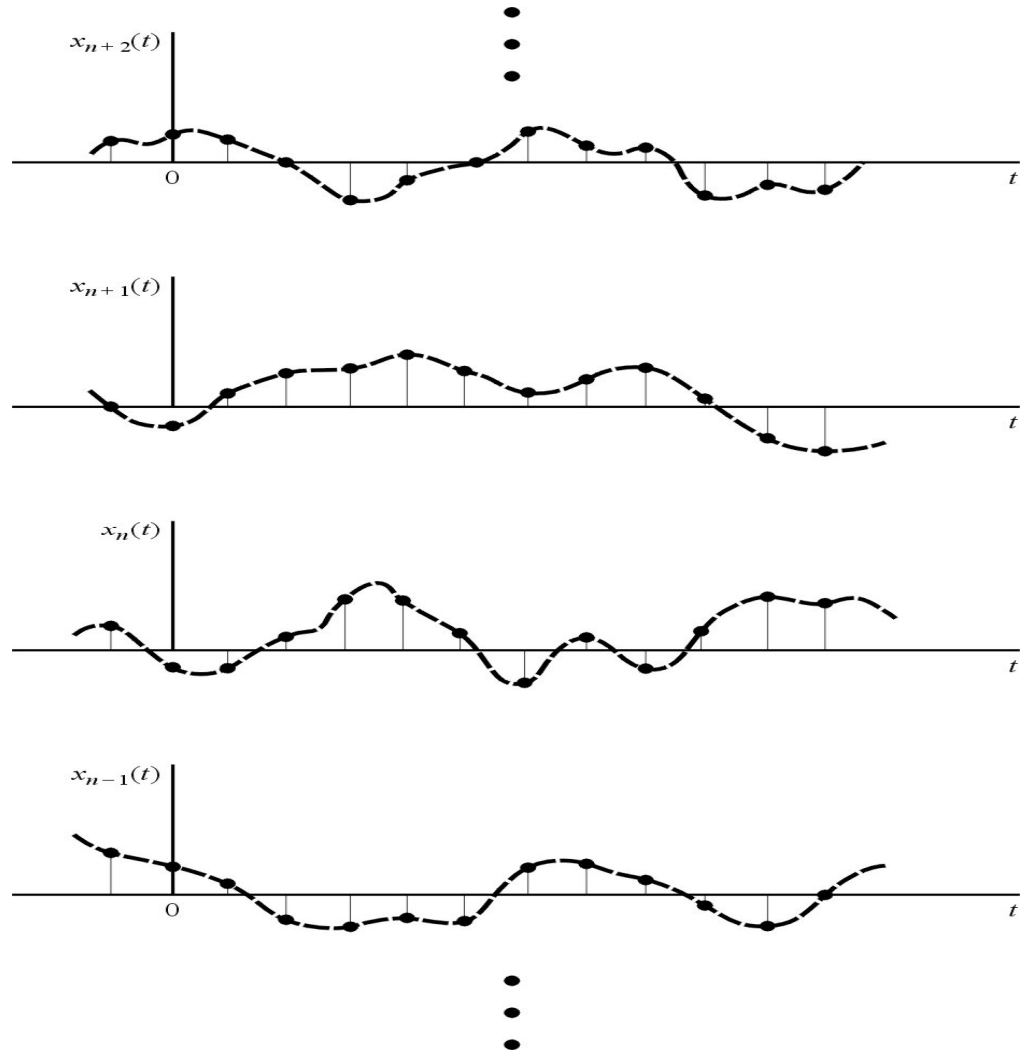

# Discrete Random Sequence

## □ Discrete random sequence

discrete time  $n$

$x(n)$  = discrete Random  
sequence

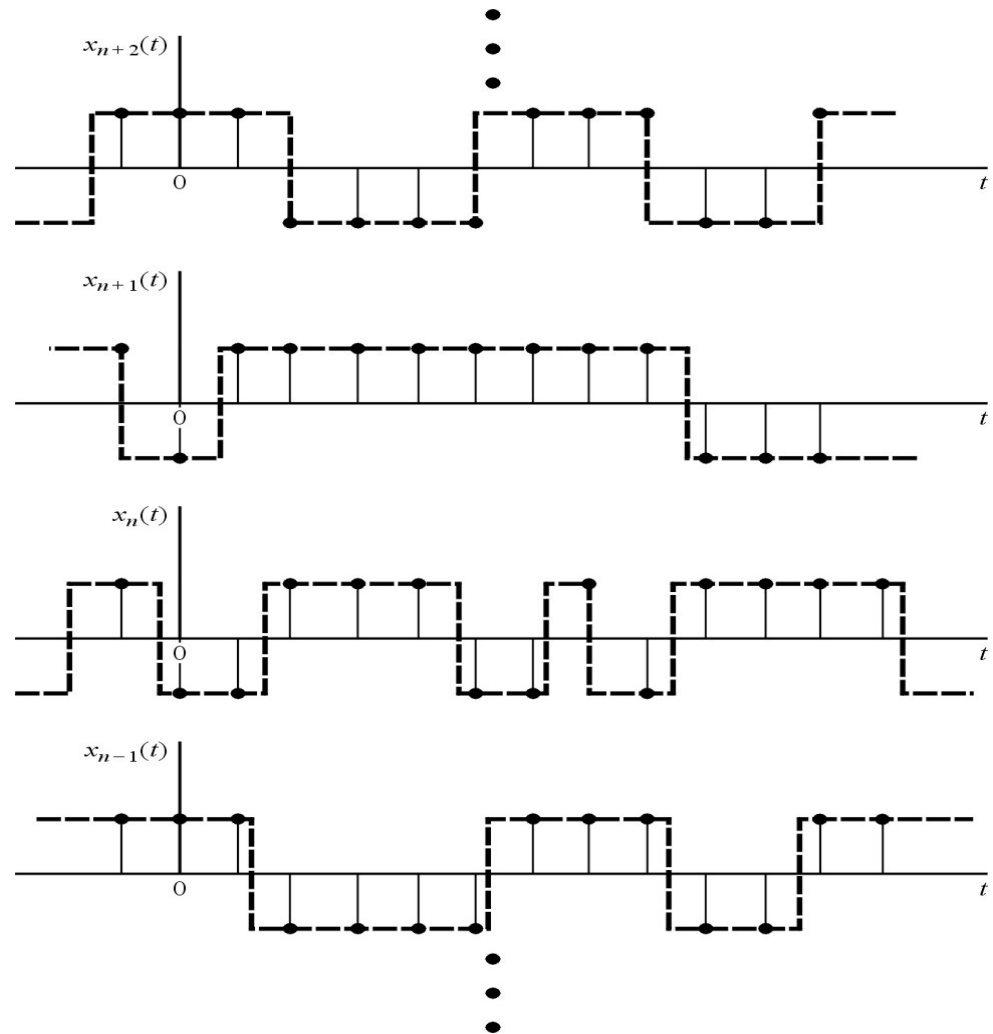



# Random Process Concept



- Deterministic random process
  - Future values of any sample function can be predicted exactly from the past values

$$X(t) = A\cos(\omega_0 t + \theta), \quad A, \omega_0, \theta: \text{ r.v.'s}$$

- Non deterministic random process
  - Future values of any sample function can not be predicted exactly from the past values

# What is a distribution and density?



- ❑ A distribution characterises the probability (mass) associated with each possible outcome of a stochastic process
- ❑ Distributions of discrete data characterised by **probability mass functions**

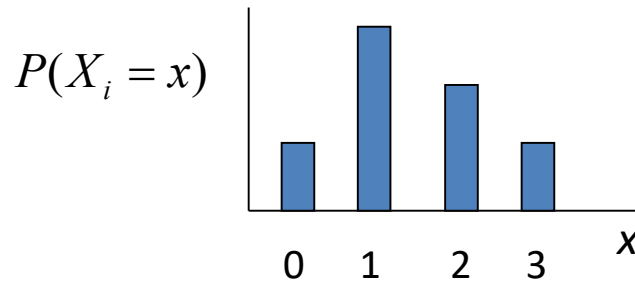

$$\sum_i P(X = x_i) = 1$$

- ❑ Distributions of continuous data are characterised by **probability density functions (pdf)**

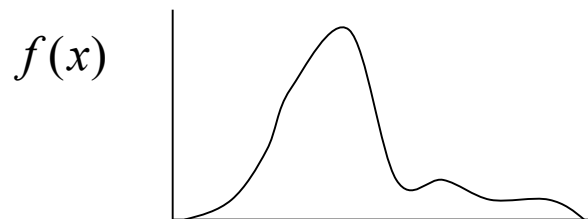

$$\int_{-\infty}^{\infty} f(x) dx = 1$$

- ❑ For RVs that map to the integers or the real numbers, the **cumulative density function (cdf)** is a useful alternative representation

# Stationary and Independence

- ❑ Stationary Random Process
  - ❑ all its statistical properties do not change with time
  
- ❑ Non Stationary Random Process
  - ❑ not stationary

One particular realization of the random process  $\{X(t)\}$

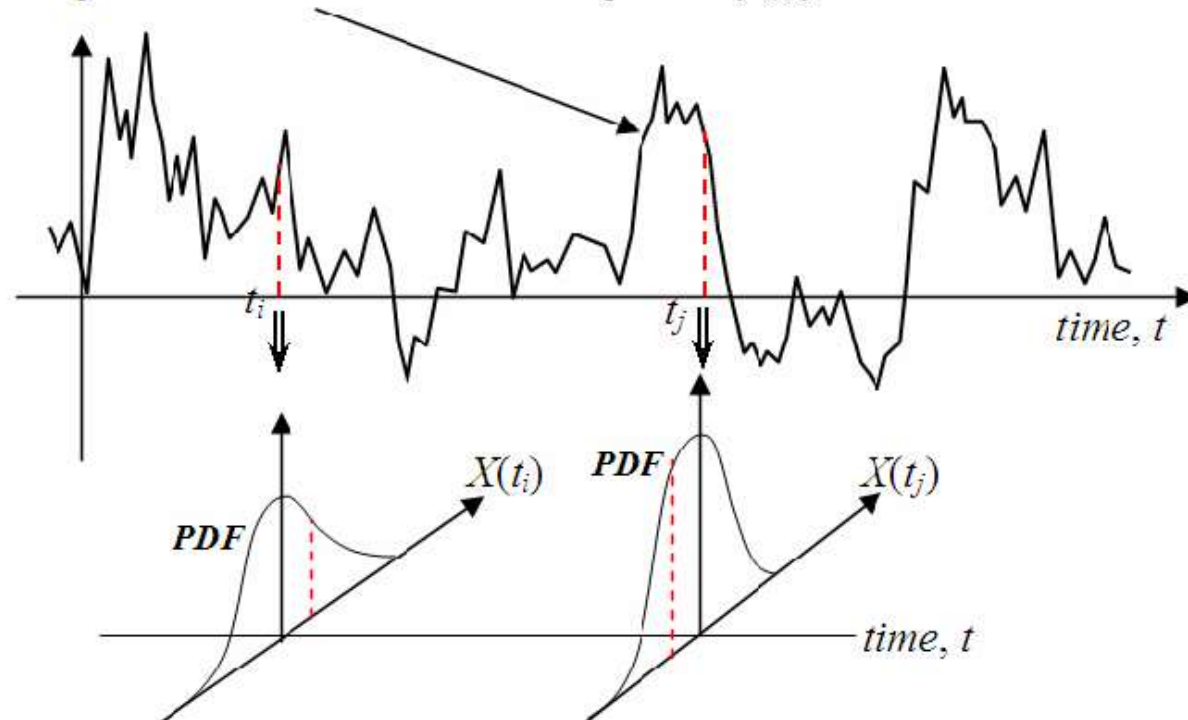

# Stationary and Independence (Contd..)



- ❑ First-order densities of a random process
  - ❑ A stochastic process is defined to be completely or totally characterized if the joint densities for the random variables  $X(t_1), X(t_2), \dots, X(t_n)$  are known for all times  $t_1, t_2, \dots, t_n$  and all  $n$ .

- ❑ For a specific  $t$ ,  $X(t)$  is a random variable with distribution

$$F(x, t) = p[X(t) \leq x]$$

- ❑ The function  $F(x, t)$  is defined as the first-order distribution of the random variable  $X(t)$ . Its derivative with respect to  $x$

$$f(x, t) = \frac{\partial F(x, t)}{\partial x}$$

is the first-order density of  $X(t)$ .

# Stationary and Independence (Contd..)



- ❑ If the first-order densities defined for all time  $t$ , i.e.  $f(x,t)$ , are all the same, then  $f(x,t)$  does not depend on  $t$  and we call the resulting density the first-order density of the random process  $\{x(t)\}$ ; otherwise, we have a family of first-order densities.
- ❑ The first-order densities (or distributions) are only a partial characterization of the random process as they do not contain information that specifies the joint densities of the random variables defined at two or more different times.

# Stationary and Independence (Contd..)



□ For  $t = t_1$  and  $t = t_2$ ,  $X(t)$  represents two different random variables  $X_1 = X(t_1)$  and  $X_2 = X(t_2)$  respectively. Their joint distribution is given by

$$F_x(x_1, x_2, t_1, t_2) = P\{X(t_1) \leq x_1, X(t_2) \leq x_2\}$$

and

$$f_x(x_1, x_2, t_1, t_2) = \frac{\partial^2 F_x(x_1, x_2, t_1, t_2)}{\partial x_1 \partial x_2}$$

represents the second-order density function of the process  $X(t)$ .

□ Similarly  $f_x(x_1, x_2, \dots, x_n, t_1, t_2, \dots, t_n)$  represents the  $n^{\text{th}}$  order density function of the process  $X(t)$ .

## Mean and variance of a random process

□ The first-order density of a random process,  $f(x,t)$ , gives the probability density of the random variables  $X(t)$  defined for all time  $t$ . The mean of a random process,  $m_X(t)$ , is thus a function of time specified by

$$m_X(t) = E[X(t)] = E[X_t] = \int_{-\infty}^{+\infty} x_t f(x_t, t) dx_t$$

□ For the case where the mean of  $X(t)$  does not depend on  $t$ , we have

$$m_X(t) = E[X(t)] = m_X \quad (\text{a constant})$$

□ The variance of a random process, also a function of time, is defined by

$$\sigma_X^2(t) = E\{[X(t) - m_X(t)]^2\} = E[X_t^2] - [m_X(t)]^2$$

# Stationary and Independence



□ The random process  $X(t)$  can be classified as follows:

□ **First-order stationary**

□ A random process is classified as **first-order stationary** if its first-order probability density function remains equal regardless of any shift in time to its time origin.

□ If we let  $X_{t_1}$  represent a given value at time  $t_1$  then we define a first-order stationary as one that satisfies the following equation:

$$f_X(x_{t_1}) = f_X(x_{t_1} + \tau)$$

□ The physical significance of this equation is that our density function,

$f_X(x_{t_1})$  is completely independent of  $t_1$   
and thus any time shift  $t$

□ For first-order stationary the mean is a constant, independent of any time shift



# Stationary and Independence (Contd..)



## ❑ Second-order stationary

❑ A random process is classified as **second-order stationary** if its second-order probability density function does not vary over any time shift applied to both values.

❑ In other words, for values  $X_{t_1}$  and  $X_{t_2}$  then we will have the following be equal for an arbitrary time shift  $t$

$$f_X(x_{t_1}, x_{t_2}) = f_X(x_{t_1+t}, x_{t_2+t})$$

❑ From this equation we see that the absolute time does not affect our functions, rather it only really depends on the time difference between the two variables.

# Stationary and Independence (Contd..)



- ❑ For a second-order stationary process, we need to look at the **autocorrelation function** ( will be presented later) to see its most important property.
- ❑ Since we have already stated that a second-order stationary process depends only on the time difference, then all of these types of processes have the following property:

$$\begin{aligned} R_{XX}(t, t+\tau) &= E[X(t)X(t+\tau)] \\ &= R_{XX}(\tau) \end{aligned}$$

# Wide-Sense Stationary (WSS)



- ❑ A process that satisfies the following:
- ❑ The mean is a constant and the autocorrelation function depends only on the difference between the time indices

$$E[X(t)] = \bar{X} = \text{constant}$$

$$E[X(t)X(t + \tau)] = R_{XX}(\tau)$$

is a Wide-Sense Stationary (WSS)

Second-order stationary



Wide-Sense Stationary

The converse is not true in general

# Wide-Sense Stationary (Example)



$$X(t) = a \cos(\omega_0 t + \varphi), \quad \varphi \sim U(0, 2\pi).$$

This gives

$$\begin{aligned} \mu_x(t) &= E\{X(t)\} = aE\{\cos(\omega_0 t + \varphi)\} \\ &= a \cos \omega_0 t E\{\cos \varphi\} - a \sin \omega_0 t E\{\sin \varphi\} = 0, \quad \text{Constant} \end{aligned}$$

since  $E\{\cos \varphi\} = \frac{1}{2\pi} \int_0^{2\pi} \cos \varphi d\varphi = 0 = E\{\sin \varphi\}$ .

Similarly

$$\begin{aligned} R_{xx}(t_1, t_2) &= a^2 E\{\cos(\omega_0 t_1 + \varphi) \cos(\omega_0 t_2 + \varphi)\} \\ &= \frac{a^2}{2} E\{\cos \omega_0(t_1 - t_2) + \cos(\omega_0(t_1 + t_2) + 2\varphi)\} \\ &= \frac{a^2}{2} \cos \omega_0(t_1 - t_2). \quad \text{So given } X(t) \text{ is WSS} \end{aligned}$$

# Nth order and Strict-Sense Stationary



□ In strict terms, the statistical properties are governed by the joint probability density function. Hence a process is  $n^{\text{th}}$ -order **Strict-Sense Stationary (S.S.S)** if

$$f_x(x_1, x_2, \dots, x_n, t_1, t_2, \dots, t_n) \equiv f_x(x_1, x_2, \dots, x_n, t_1 + c, t_2 + c, \dots, t_n + c) \rightarrow (1)$$

□ For *any*  $c$ , where the left side represents the joint density function of the random variables  $X_1 = X(t_1), X_2 = X(t_2), \dots, X_n = X(t_n)$  and the right side corresponds to the joint density function of the random variables  $X'_1 = X(t_1 + c), X'_2 = X(t_2 + c), \dots, X'_n = X(t_n + c)$ .

□ A process  $X(t)$  is said to be **strict-sense stationary** if equation (1) true for all  $t_i, i = 1, 2, \dots, n, n = 1, 2, \dots$  and *any*  $c$ .

# Ergodic Process



A stationary random process for which time averages equal ensemble averages is called an ergodic process:

$$\langle x [n] \rangle = m_x$$

$$\langle x [n + m] x [n]^* \rangle = \phi_{xx} [m]$$

# Ergodic Process (Contd..)



It is common to assume that a given sequence is a sample sequence of an ergodic random process, so that averages can be computed from a single sequence.

In practice, we cannot compute with the limits, but instead the quantities.

Similar quantities are often computed as estimates of the mean, variance, and autocorrelation.

$$\hat{m}_x = \frac{1}{L} \sum_{n=0}^{L-1} x[n]$$

$$\sigma_x^2 = \frac{1}{L} \sum_{n=0}^{L-1} (x[n] - \hat{m}_x)^2$$

$$\langle x[n+m]x^*[n] \rangle_L = \frac{1}{L} \sum_{n=0}^{L-1} x[n+m]x^*[n]$$

# Time Average and Ergodicity



- The time average of a quantity is defined as

$$A[\bullet] = \lim_{T \rightarrow \infty} \frac{1}{2T} \int_{-T}^T [\bullet] dt$$

Here A is used to denote time average in a manner analogous to E for the statistical average.

- The time average is taken over all time because, as applied to random processes, sample functions of processes are presumed to exist for all time.



# Time Average and Ergodicity (Contd..)



□ Let  $x(t)$  be a sample of the random process  $X(t)$  where the lower case letter imply a sample function.

□ We define the mean value  $\bar{x} = A[x(t)]$

( a lowercase letter is used to imply a sample function)

and the time autocorrelation function  $\mathcal{R}_{XX}(\tau)$  as follows:

$$\bar{x} = A[x(t)] = \lim_{T \rightarrow \infty} \frac{1}{2T} \int_{-T}^T x(t) dt$$

$$\mathcal{R}_{XX}(\tau) = A[x(t)x(t + \tau)] = \lim_{T \rightarrow \infty} \frac{1}{2T} \int_{-T}^T x(t)x(t + \tau) dt$$

□ For any one sample function ( i.e.,  $x(t)$  ) of the random process  $X(t)$ , the last two integrals simply produce two numbers.

□ A number for the average  $\bar{x}$  and a number for  $\mathcal{R}_{XX}(\tau)$  for a specific value of  $\tau$

# Time Average and Ergodicity (Contd..)



- Since the sample function  $x(t)$  is one out of other samples functions of the random process  $X(t)$ ,
- The average  $\bar{x}$  and the autocorrelation  $\mathcal{R}_{XX}(\tau)$  are random variables
- By taking the expected value for  $\bar{X}$  and  $\mathcal{R}_{XX}(\tau)$ , we obtain

$$E[\bar{x}] = E[A[x(t)]] = E\left[\lim_{T \rightarrow \infty} \frac{1}{2T} \int_{-T}^T x(t) dt\right] = \lim_{T \rightarrow \infty} \frac{1}{2T} \int_{-T}^T E[x(t)] dt$$

$$= \lim_{T \rightarrow \infty} \frac{1}{2T} \int_{-T}^T \bar{X} dt = \lim_{T \rightarrow \infty} \bar{X}(1) = \bar{X}$$

$$E[\mathcal{R}_{XX}(\tau)] = E[A[x(t)x(t+\tau)]] = E\left[\lim_{T \rightarrow \infty} \frac{1}{2T} \int_{-T}^T x(t)x(t+\tau) dt\right]$$

$$= \lim_{T \rightarrow \infty} \frac{1}{2T} \int_{-T}^T E[x(t)x(t+\tau)] dt = \lim_{T \rightarrow \infty} \frac{1}{2T} \int_{-T}^T \mathcal{R}_{XX}(\tau) dt = \mathcal{R}_{XX}(\tau)$$

# Time Average and Ergodicity (Contd..)



- Time cross correlation

$$\mathfrak{R}_{xy}(\tau) = A[x(t)y(t+\tau)] = \lim_{T \rightarrow \infty} \frac{1}{2T} \int_{-T}^T x(t)y(t+\tau)dt$$

- Ergodic  $\Rightarrow \bar{x} = \bar{X}$

$$\mathfrak{R}_{xx}(\tau) = R_{XX}(\tau)$$

- Jointly Ergodic  $\Rightarrow$  Ergodic  $X(t)$  and  $Y(t)$

$$\mathfrak{R}_{xy}(\tau) = R_{XY}(\tau)$$

# Introduction to Autocorrelation



- ❑ Autocorrelation occurs in time-series studies when the errors associated with a given time period carry over into future time periods.
- ❑ For example, if we are predicting the growth of stock dividends, an overestimate in one year is likely to lead to overestimates in succeeding years.
- ❑ Times series data follow a natural ordering over time.
- ❑ It is likely that such data exhibit intercorrelation, especially if the time interval between successive observations is short, such as weeks or days.

# Introduction (contd..)



- ❑ We expect stock market prices to move or move down for several days in succession.
- ❑ We experience autocorrelation when
$$E(u_i u_j) \neq 0$$
- ❑ Tintner defines autocorrelation as 'lag correlation of a given series within itself, lagged by a number of times MODULES' whereas serial correlation is the 'lag correlation between two different series'.

# Autocorrelation and its Properties



- The autocorrelation function of a random process  $X(t)$  is the correlation  $E[X_1 X_2]$  of two random variables  $X_1 = X(t_1)$  and  $X_2 = X(t_2)$  by the process at times  $t_1$  and  $t_2$

$$R_{XX}(t_1, t_2) = E[X(t_1)X(t_2)]$$

- Assuming a second-order stationary process

$$R_{XX}(t, t + \tau) = E[X(t)X(t + \tau)] \quad R_{XX}(\tau) = E[X(t)X(t + \tau)]$$

# Autocorrelation and its Properties (Contd.)



## Autocorrelation :

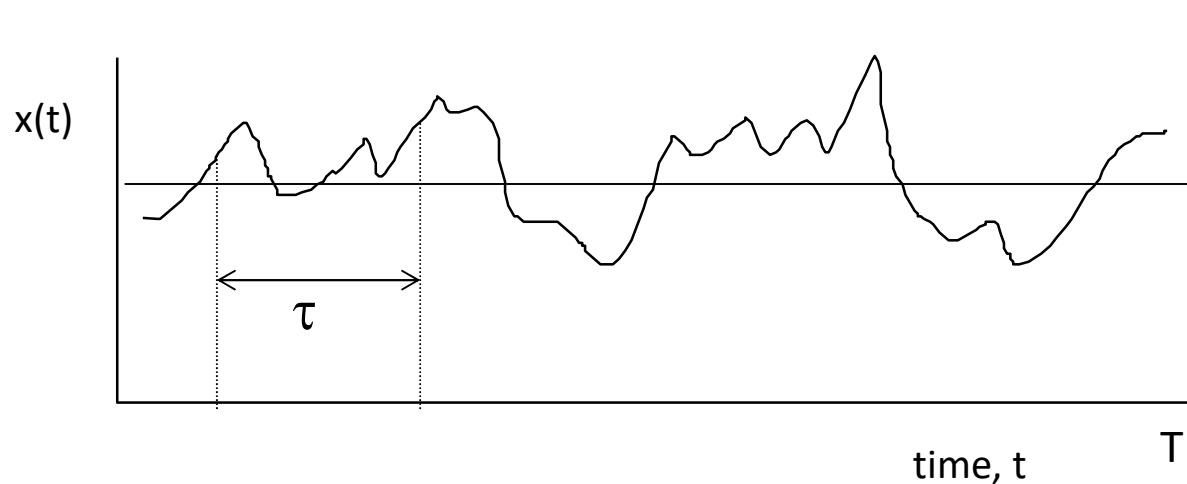

- The autocorrelation, or auto covariance, describes the general dependency of  $x(t)$  with its value at a short time later,  $x(t+\tau)$

$$\rho_x(\tau) = \lim_{T \rightarrow \infty} \frac{1}{T} \int_0^T [x(t) - \bar{x}][x(t + \tau) - \bar{x}] dt$$

- The value of  $\rho_x(\tau)$  at  $\tau$  equal to 0 is the variance,  $\sigma_x^2$
- Normalized auto-correlation :  $R(\tau) = \rho_x(\tau) / \sigma_x^2$   $R(0) = 1$

# Autocorrelation and its Properties (Contd.)

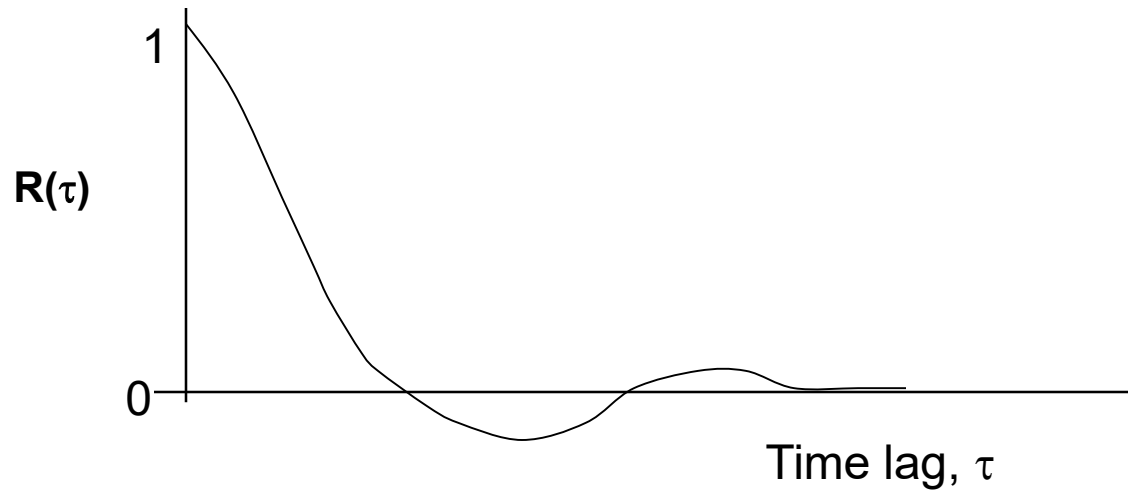

- The autocorrelation for a random process eventually decays to zero at large  $\tau$
- The autocorrelation for a sinusoidal process (deterministic) is a cosine function which does not decay to zero



# Autocorrelation and its Properties (Contd.)

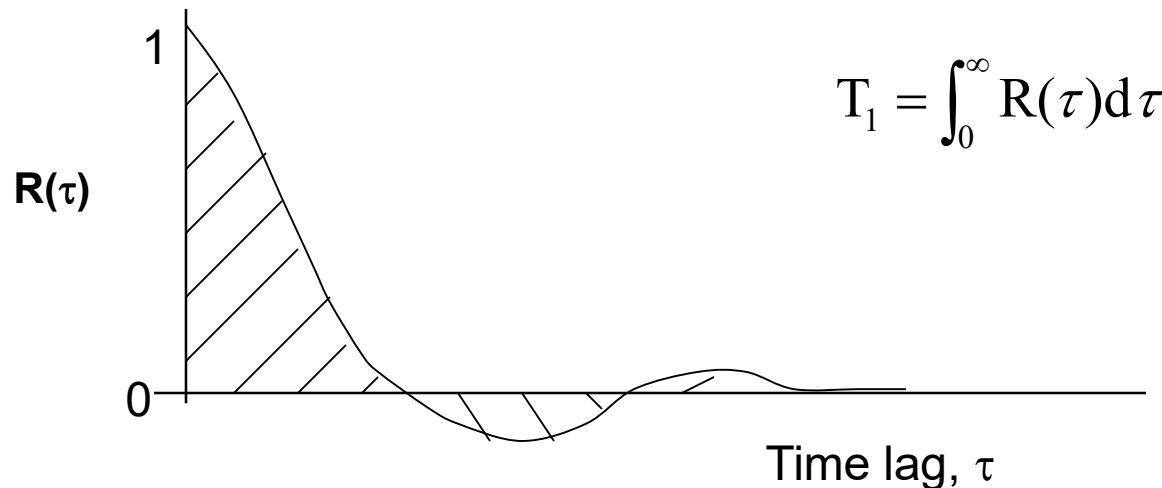

- ❑ The area under the normalized autocorrelation function for the fluctuating wind velocity measured at a point is a measure of the average time scale of the eddies being carried passed the measurement point, say  $T_1$
- ❑ If we assume that the eddies are being swept passed at the mean velocity,  $\bar{U} \cdot T_1$  is a measure of the average length scale of the eddies. This is known as the 'integral length scale', denoted by  $l_u$

# Autocorrelation and its Properties (Contd.)



## □ Properties of Autocorrelation function

$$R_{XX}(t, t + \tau) = E[X(t)X(t + \tau)] = R_{XX}(\tau)$$

(1)  $|R_{XX}(\tau)| \leq R_{XX}(0)$

(2)  $R_{XX}(-\tau) = R_{XX}(\tau)$

(3)  $R_{XX}(0) = E[X(t)^2]$

(4) stationary & ergodic  $X(t)$  with no periodic components

$$\Rightarrow \lim_{|\tau| \rightarrow \infty} R_{XX}(\tau) = \overline{X}^2$$

(5) stationary  $X(t)$  has a periodic component

$\Rightarrow R_{XX}(\tau)$  has a periodic component with the same period.

# Cross-correlation

## □ Cross-correlation

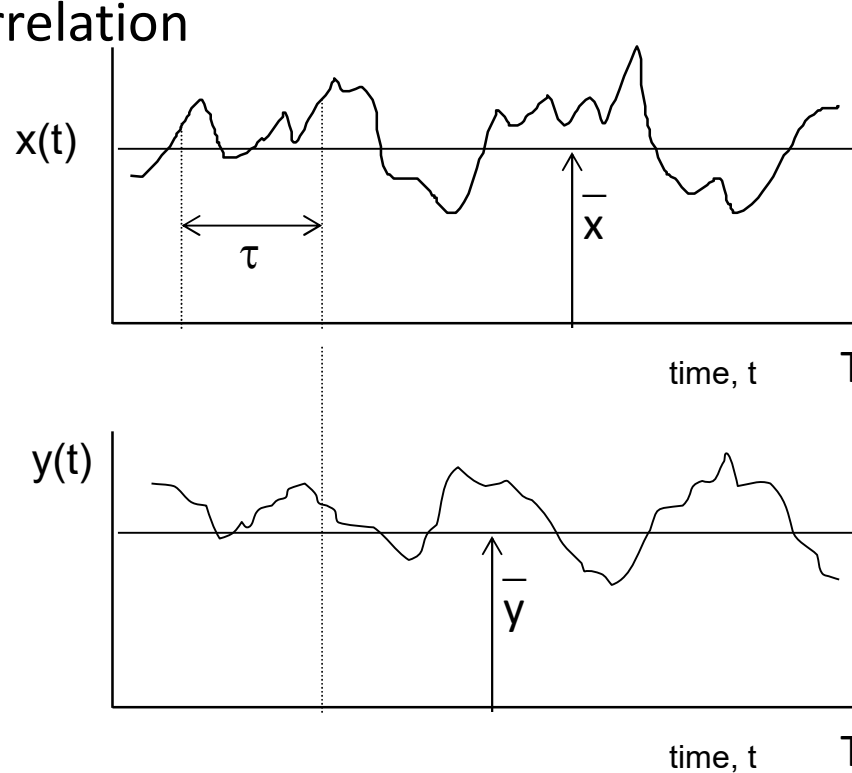

- The cross-correlation function describes the general dependency of  $x(t)$  with another random process  $y(t+\tau)$ , delayed by a time delay,  $\tau$

$$c_{xy}(\tau) = \lim_{T \rightarrow \infty} \frac{1}{T} \int_0^T [x(t) - \bar{x}][y(t+\tau) - \bar{y}] dt$$

# Correlation coefficient



## □ Correlation coefficient

- The correlation coefficient,  $\rho$ , is the covariance normalized by the standard deviations of  $x$  and  $y$

$$\rho = \frac{\overline{x'(t).y'(t)}}{\sigma_x \cdot \sigma_y}$$

When  $x$  and  $y$  are identical to each other, the value of  $\rho$  is +1 (full correlation)

When  $y(t)=-x(t)$ , the value of  $\rho$  is  $-1$

In general,  $-1 < \rho < +1$

# Application of correlation

□ Correlation - application :

- The fluctuating wind loading of a tower depends on the correlation coefficient between wind velocities and hence wind loads, at various heights

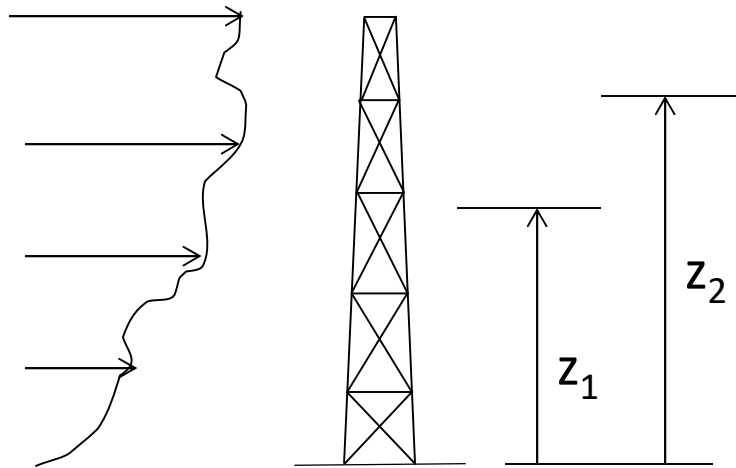

For heights,  $z_1$ , and  $z_2$   
:

$$\rho(z_1, z_2) = \frac{\overline{u'(z_1) \cdot u'(z_2)}}{\sigma_u(z_1) \cdot \sigma_u(z_2)}$$

# Properties of Cross Correlation



Properties of cross-correlation function of jointly w.s.s. r.p.'s:

$$R_{XY}(\tau) = E[X(t)Y(t + \tau)]$$

$$(1) \quad R_{XY}(-\tau) = R_{YX}(\tau)$$

$$(2) \quad |R_{XY}(\tau)| \leq \sqrt{R_{XX}(0)R_{YY}(0)}$$

$$(3) \quad |R_{XY}(\tau)| \leq \frac{1}{2}[R_{XX}(0) + R_{YY}(0)]$$

$$E[\{Y(t + \tau) + \alpha X(t)\}^2] \geq 0, \quad \forall \alpha$$

$$\sqrt{R_{XX}(0)R_{YY}(0)} \leq \frac{1}{2}[R_{XX}(0) + R_{YY}(0)]$$

# Example of Cross Correlation



$$A, B : \text{r.v.'s} \quad \omega_0 = \text{const}$$

$$E[A] = E[B] = 0, \quad E[AB] = 0, \quad E[A^2] = E[B^2] = \sigma^2$$

$$X(t) = A \cos(\omega_0 t) + B \sin(\omega_0 t), \quad Y(t) = B \cos(\omega_0 t) - A \sin(\omega_0 t)$$

$$E[X(t)] = E[A \cos(\omega_0 t) + B \sin(\omega_0 t)] = E[A] \cos(\omega_0 t) + E[B] \sin(\omega_0 t) = 0$$

$$R_{XX}(t, t + \tau) = E[X(t)X(t + \tau)]$$

$$= E[A^2 \cos(\omega_0 t) \cos(\omega_0 t + \omega_0 \tau) + AB \cos(\omega_0 t) \sin(\omega_0 t + \omega_0 \tau) \\ + AB \sin(\omega_0 t) \cos(\omega_0 t + \omega_0 \tau) + B^2 \sin(\omega_0 t) \sin(\omega_0 t + \omega_0 \tau)]$$

$$= \sigma^2 \{ \cos(\omega_0 t) \cos(\omega_0 t + \omega_0 \tau) + \sin(\omega_0 t) \sin(\omega_0 t + \omega_0 \tau) \} = \sigma^2 \cos(\omega_0 \tau)$$

$\Rightarrow X(t) : \text{w.s.s.}$

# Example of Cross Correlation



$Y(t)$ : w.s.s.

$$\begin{aligned}R_{XY}(\tau) &= E[X(t)Y(t+\tau)] \\&= E\{[A\cos(\omega_0 t) + B\sin(\omega_0 t)][B\cos(\omega_0(t+\tau)) - A\sin(\omega_0(t+\tau))]\} \\&= E[AB\cos(\omega_0 t)\cos(\omega_0 t + \omega_0 \tau) + B^2\sin(\omega_0 t)\cos(\omega_0 t + \omega_0 \tau) \\&\quad - A^2\cos(\omega_0 t)\sin(\omega_0 t + \omega_0 \tau) - AB\sin(\omega_0 t)\sin(\omega_0 t + \omega_0 \tau)] \\&= \sigma^2[\sin(\omega_0 t)\cos(\omega_0 t + \omega_0 \tau) - \cos(\omega_0 t)\sin(\omega_0 t + \omega_0 \tau)] \\&= -\sigma^2\sin(\omega_0 \tau)\end{aligned}$$

$\Rightarrow X(t)$  &  $Y(t)$ : jointly w.s.s.



# Covariance



## □ Covariance

- The covariance is the cross correlation function with the time delay,  $\tau$ , set to zero

$$c_{xy}(0) = \overline{x'(t).y'(t)} = \lim_{T \rightarrow \infty} \frac{1}{T} \int_0^T [x(t) - \bar{x}][y(t) - \bar{y}] dt$$

- Note that here  $x'(t)$  and  $y'(t)$  are used to denote the fluctuating parts of  $x(t)$  and  $y(t)$  (mean parts subtracted)

# Auto Covariance



- ❑ The auto covariance  $C_x(t_1, t_2)$  of a random process  $X(t)$  is defined as the covariance of  $X(t_1)$  and  $X(t_2)$

$$C_x(t_1, t_2) = E[\{X(t_1) - m_x(t_1)\}\{X(t_2) - m_x(t_2)\}]$$

$$C_x(t_1, t_2) = R_x(t_1, t_2) - m_x(t_1)m_x(t_2)$$

- ❑ The variance of  $X(t)$  can be obtained from  $C_x(t_1, t_2)$

$$\text{VAR}[X(t)] = E[(X(t) - m_x(t))^2] = C_x(t, t)$$

- ❑ The correlation coefficient of  $X(t)$  is given by

$$\rho_x(t_1, t_2) = \frac{C_x(t_1, t_2)}{\sqrt{C_x(t_1, t_1)}\sqrt{C_x(t_2, t_2)}}$$

$$|\rho_x(t_1, t_2)| \leq 1$$

# Auto Covariance Example#1



## Example:

Let  $X(t) = A \cos 2\pi t$ , where  $A$  is some random variable

The mean of  $X(t)$  is given by

$$m_X(t) = E[A \cos 2\pi t] = E[A] \cos 2\pi t$$

The autocorrelation is

$$R_X(t_1, t_2) = E[A \cos(2\pi t_1) A \cos(2\pi t_2)]$$

$$R_X(t_1, t_2) = E[A^2] \cos(2\pi t_1) \cos(2\pi t_2)$$

And the autocovariance

$$C_X(t_1, t_2) = R_X(t_1, t_2) - m_X(t_1)m_X(t_2)$$

$$C_X(t_1, t_2) = \{E[A^2] - E[A]^2\} \cos(2\pi t_1) \cos(2\pi t_2)$$

$$C_X(t_1, t_2) = VAR[A] \cos(2\pi t_1) \cos(2\pi t_2)$$

# Auto Covariance Example#2



## Example:

Let  $X(t) = \cos(\omega t + \theta)$ , where  $\theta$  is uniformly distributed in the interval  $(-\pi, \pi)$ .

The mean of  $X(t)$  is given by

$$m_X(t) = E[\cos(\omega t + \theta)] = \frac{1}{2\pi} \int_{-\pi}^{\pi} \cos(\omega t + \theta) = 0$$

The autocorrelation and autocovariance are then

$$C_X(t_1, t_2) = R_X(t_1, t_2) = E[\cos(\omega t_1 + \theta) \cos(\omega t_2 + \theta)]$$

$$C_X(t_1, t_2) = \frac{1}{2\pi} \int_{-\pi}^{\pi} \frac{1}{2} \{ \cos(\omega(t_1 - t_2)) + \cos(\omega(t_1 + t_2) + 2\theta) \} d\theta$$

$$C_X(t_1, t_2) = \frac{1}{2} \cos(\omega(t_1 - t_2))$$

# Cross Covariance



- ❑ The cross covariance  $C_{x,y}(t_1,t_2)$  of a random process  $X(t)$  and  $Y(t)$  is defined as

$$C_{x,y}(t_1,t_2) = E[\{X(t_1) - m_x(t_1)\}\{Y(t_2) - m_y(t_2)\}]$$

$$C_{x,y}(t_1,t_2) = R_{x,y}(t_1,t_2) - m_x(t_1)m_y(t_2)$$

- ❑ The process  $X(t)$  and  $Y(t)$  are said to be uncorrelated if  
 $C_{x,y}(t_1,t_2) = 0$  for all  $t_1, t_2$

# Random sequence



Random Sequence (=Discrete-time R.P)

$$X(nT_s) = X[n]$$

$$\text{Mean} = E(X[n])$$

$$R_{XX}(n, n+k) = E(X[n]X[n+k])$$

$$\begin{aligned} C_{XX}(n, n+k) &= E\{(X[n] - \bar{X}[n])(X[n+k] - \bar{X}[n+k])\} \\ &= R_{XX}(n, n+k) - \bar{X}[n]\bar{X}[n+k] \end{aligned}$$

$$R_{XY}(n, n+k) = E(X[n]Y[n+k])$$

$$\begin{aligned} C_{XY}(n, n+k) &= E\{(X[n] - \bar{X}[n])(Y[n+k] - \bar{Y}[n+k])\} \\ &= R_{XY}(n, n+k) - \bar{X}[n]\bar{Y}[n+k] \end{aligned}$$

# Gaussian Random Process



□ Let  $X(t)$  be a random process and let  $X(t_1), X(t_2), \dots, X(t_n)$  be the random variables obtained from  $X(t)$  at  $t=t_1, t_2, \dots, t_n$  sec respectively

□ Let all these random variables be expressed in the form of a matrix

$$X = \begin{bmatrix} X(t_1) \\ X(t_2) \\ \vdots \\ X(t_n) \end{bmatrix}$$

□ Then,  $X(t)$  is referred to as normal or Gaussian process if all the elements of  $X$  are jointly Gaussian

# Gaussian Random Process



- continuous r.p.  $X(t)$ ,  $-\infty < t < \infty$

$$f_X(x_1, \dots, x_N; t_1, \dots, t_N) = \frac{1}{\sqrt{(2\pi)^N |C_X|}} \exp\left\{-\frac{1}{2}[x - \bar{X}]^t C_X^{-1}[x - \bar{X}]\right\}$$

$$\bar{X}_i = E[X(t_i)] \quad C_{ik} = C_{XX}(t_i, t_k)$$

stationary  $\Rightarrow E[X(t)] = \bar{X}$  (const) &  $R_{XX}(t_i, t_k) = R_{XX}(t_k - t_i)$

$$C_{XX}(t_i, t_k) = C_{XX}(t_k - t_i)$$

w.s.s. Gaussian  $\Rightarrow$  strictly stationary



# Gaussian Random Process



w.s.s. gaussian r.p.  $X(t)$

$$\bar{X} = 4 \quad R_{XX}(\tau) = 25e^{-3|\tau|} \quad t_i = t_0 + \frac{i-1}{2}, \quad i = 1, 2, 3.$$

$$C_{ik} = C_{XX}(t_i, t_k) = R_{XX}(t_i, t_k) - \bar{X}^2 = 25e^{-3\frac{|k-i|}{2}} - 16$$

$$C_X = \begin{bmatrix} C_{11} & C_{12} & C_{13} \\ C_{21} & C_{22} & C_{23} \\ C_{31} & C_{32} & C_{33} \end{bmatrix} = \begin{bmatrix} 25-16 & 25e^{-\frac{3}{2}}-16 & 25e^{-3}-16 \\ 25e^{-\frac{3}{2}}-16 & 25-16 & 25e^{-\frac{3}{2}}-16 \\ 25e^{-3}-16 & 25e^{-\frac{3}{2}}-16 & 25-16 \end{bmatrix}$$

# Properties of Gaussian Process



- ❑ If a gaussian process  $X(t)$  is applied to a stable linear filter, then the random process  $Y(t)$  developed at the output of the filter is also gaussian.
- ❑ Considering the set of random variables or samples  $X(t_1), X(t_2), \dots, X(t_n)$  obtained by observation of a random process  $X(t)$  at instants  $t_1, t_2, \dots, t_n$ , if the process  $X(t)$  is gaussian, then this set of random variables are jointly gaussian for any  $n$ , with their  $n$ -fold joint p.d.f. being completely determined by the set of means.

$$m_x(t_i) = E[X(t_i)] \text{ for } i=1,2,\dots,n$$

and the set of auto covariance function

$$C_{xx}(t_1, t_2) = E[\{X(t_1) - E[X(t_1)]\}\{X(t_2) - E[X(t_2)]\}]$$

- ❑ If a gaussian process is wide sense stationary, then the process is also stationary in the strict sense
- ❑ If the set of random variables  $X(t_1), X(t_2), \dots, X(t_n)$  are uncorrelated then they are statistically independent

# Poisson Random Process



□ we introduced Poisson arrivals as the limiting behavior of Binomial random variables

where

$$P \left\{ \begin{array}{l} "k \text{ arrivals occur in an} \\ \text{interval of duration } \Delta" \end{array} \right\} = e^{-\lambda} \frac{\lambda^k}{k!}, \quad k = 0, 1, 2, \dots$$

$$\lambda = np = \mu T \cdot \frac{\Delta}{T} = \mu \Delta$$

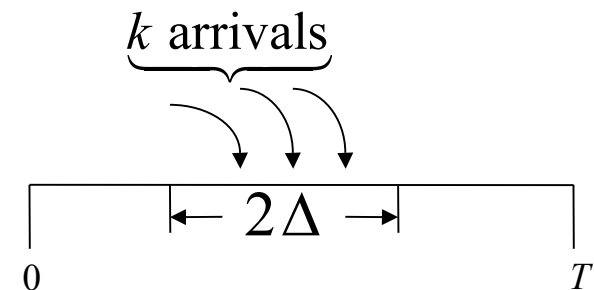
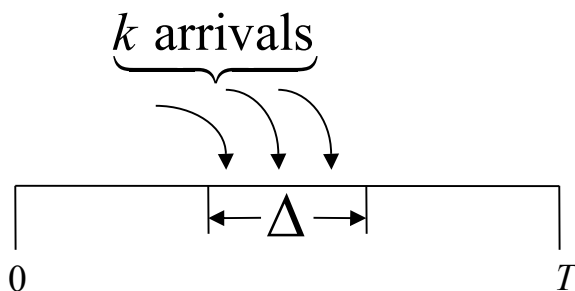

# Poisson Random Process (contd..)



□ It follows that

$$P \left\{ \begin{array}{l} "k \text{ arrivals occur in an} \\ \text{interval of duration } 2\Delta" \end{array} \right\} = e^{-2\lambda} \frac{(2\lambda)^k}{k!}, \quad k = 0, 1, 2, \dots,$$

since in that case

$$np_1 = \mu T \cdot \frac{2\Delta}{T} = 2\mu\Delta = 2\lambda.$$

□ From the above equations, Poisson arrivals over an interval form a Poisson random variable whose parameter depends on the duration of that interval.

□ The Bernoulli nature of the underlying basic random arrivals, events over non overlapping intervals are independent. We shall use these two key observations to define a Poisson process formally.

# Poisson Random Process (contd..)



□ **Definition:**  $X(t) = n(0, t)$  represents a Poisson process if

(i) the number of arrivals  $n(t_1, t_2)$  in an interval  $(t_1, t_2)$  of length  $t = t_2 - t_1$  is a Poisson random variable with parameter  $\lambda t$ .

Thus

$$P\{n(t_1, t_2) = k\} = e^{-\lambda t} \frac{(\lambda t)^k}{k!}, \quad k = 0, 1, 2, \dots, \quad t = t_2 - t_1$$

and

(ii) If the intervals  $(t_1, t_2)$  and  $(t_3, t_4)$  are non overlapping, then the random variables  $n(t_1, t_2)$  and  $n(t_3, t_4)$  are independent.

Since  $n(0, t) \sim P(\lambda t)$ , we have

$$E[X(t)] = E[n(0, t)] = \lambda t$$

and

$$E[X^2(t)] = E[n^2(0, t)] = \lambda t + \lambda^2 t^2.$$

# Poisson Random Process (contd..)



□ To determine the autocorrelation function  $R_{xx}(t_1, t_2)$ , let  $t_2 > t_1$ , then from (ii) above  $n(0, t_1)$  and  $n(t_1, t_2)$  are independent Poisson random variables with parameters  $\lambda t_1$  and  $\lambda(t_2 - t_1)$  respectively.

Thus

$$E[n(0, t_1)n(t_1, t_2)] = E[n(0, t_1)]E[n(t_1, t_2)] = \lambda^2 t_1 (t_2 - t_1).$$

But

$$n(t_1, t_2) = n(0, t_2) - n(0, t_1) = X(t_2) - X(t_1)$$

and hence the left side of above equation can be rewritten as

$$E[X(t_1)\{X(t_2) - X(t_1)\}] = R_{xx}(t_1, t_2) - E[X^2(t_1)].$$

$$\begin{aligned} R_{xx}(t_1, t_2) &= \lambda^2 t_1 (t_2 - t_1) + E[X^2(t_1)] \\ &= \lambda t_1 + \lambda^2 t_1 t_2, \quad t_2 \geq t_1. \end{aligned}$$

Similarly

$$R_{xx}(t_1, t_2) = \lambda t_2 + \lambda^2 t_1 t_2, \quad t_2 < t_1.$$

Thus

$$R_{xx}(t_1, t_2) = \lambda^2 t_1 t_2 + \lambda \min(t_1, t_2).$$

# Poisson Random Process (contd..)

❑ Notice that the Poisson process  $X(t)$  does not represent a wide sense stationary process.

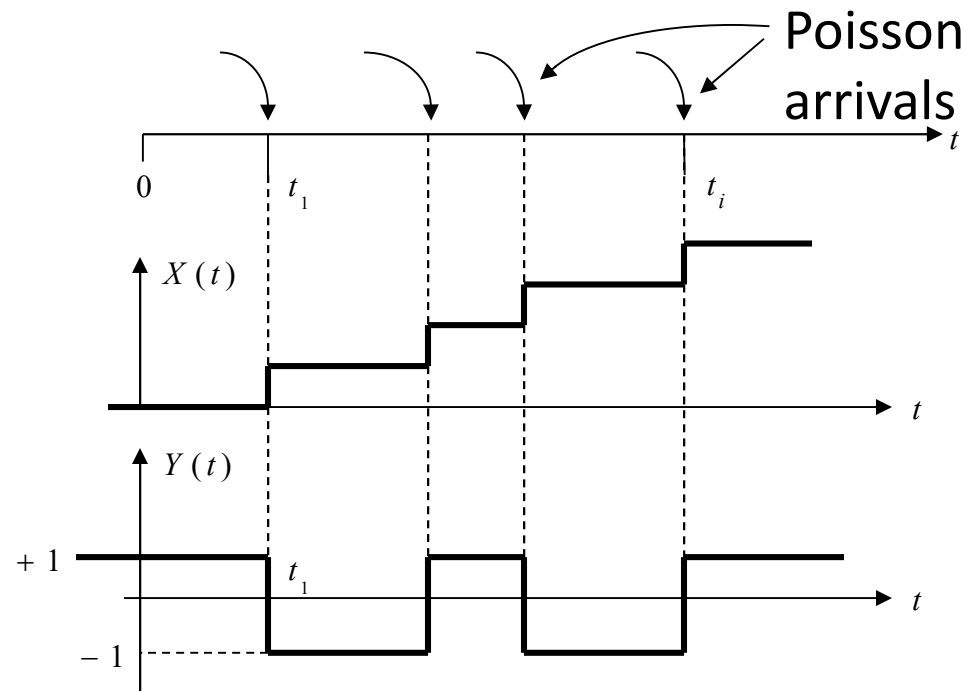

❑ Define a binary level process

$$Y(t) = (-1)^{X(t)}$$

that represents a telegraph signal. Notice that the transition instants  $\{t_i\}$  are random. Although  $X(t)$  does not represent a wide sense stationary process,

# Poisson Random Process (contd..)



its derivative  $X'(t)$  does represent a wide sense stationary process.

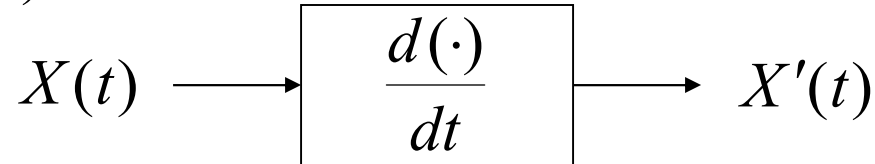

(Derivative as a LTI system)

From there

$$\mu_{X'}(t) = \frac{d\mu_X(t)}{dt} = \frac{d\lambda t}{dt} = \lambda, \quad \text{a constant}$$

and

$$R_{XX'}(t_1, t_2) = \frac{\partial R_{XX}(t_1, t_2)}{\partial t_2} = \begin{cases} \lambda^2 t_1 & t_1 \leq t_2 \\ \lambda^2 t_1 + \lambda & t_1 > t_2 \end{cases}$$

and

$$R_{XX'}(t_1, t_2) = \lambda^2 t_1 + \lambda U(t_1 - t_2)$$
$$R_{XX'}(t_1, t_2) = \frac{\partial R_{XX'}(t_1, t_2)}{\partial t_1} = \lambda^2 + \lambda \delta(t_1 - t_2).$$



# Poisson Random Process (contd..)



Define the processes

$$Y(t) = \sum_{i=1}^{X(t)} N_i \quad ; \quad Z(t) = \sum_{i=1}^{X(t)} (1 - N_i) = X(t) - Y(t)$$

we claim that both  $Y(t)$  and  $Z(t)$  are independent Poisson processes with parameters  $\lambda pt$  and  $\lambda qt$  respectively.

**Proof:**

$$Y(t) = \sum_{n=k}^{\infty} P\{Y(t) = k \mid X(t) = n\} P\{X(t) = n\}.$$

But given  $X(t) = n$ , we have  $Y(t) = \sum_{i=1}^n N_i \sim B(n, p)$  so that

$$P\{Y(t) = k \mid X(t) = n\} = \binom{n}{k} p^k q^{n-k}, \quad 0 \leq k \leq n,$$

and

$$P\{X(t) = n\} = e^{-\lambda t} \frac{(\lambda t)^n}{n!}.$$

# Poisson Random Process (contd..)



$$\begin{aligned}
 P\{Y(t) = k\} &= e^{-\lambda t} \sum_{n=k}^{\infty} \frac{n!}{(n-k)!k!} p^k q^{n-k} \frac{(\lambda t)^n}{n!} = \frac{p^k e^{-\lambda t}}{k!} (\lambda t)^k \underbrace{\sum_{n=k}^{\infty} \frac{(q\lambda t)^{n-k}}{(n-k)!}}_{e^{q\lambda t}} \\
 &= (\lambda pt)^k \frac{e^{-(1-q)\lambda t}}{k!} = e^{-\lambda pt} \frac{(\lambda pt)^k}{k!}, \quad k = 0, 1, 2, \dots \\
 &\sim P(\lambda pt).
 \end{aligned}$$

More generally,

$$\begin{aligned}
 P\{Y(t) = k, Z(t) = m\} &= P\{Y(t) = k, X(t) - Y(t) = m\} \\
 &= P\{Y(t) = k, X(t) = k + m\} \\
 &= P\{Y(t) = k \mid X(t) = k + m\} P\{X(t) = k + m\} \\
 &= \binom{k+m}{k} p^k q^m \cdot e^{-\lambda t} \frac{(\lambda t)^{k+m}}{(k+m)!} = \underbrace{e^{-\lambda pt} \frac{(\lambda pt)^k}{k!}}_{P\{Y(t)=k\}} \underbrace{e^{-\lambda qt} \frac{(\lambda qt)^m}{m!}}_{P\{Z(t)=m\}} \\
 &= P\{Y(t) = k\} P\{Z(t) = m\}, \quad \text{which completes the proof.}
 \end{aligned}$$

# Poisson Random Process (contd..)



-- integer-valued discrete r.p.  $X(t)$ ,  $-\infty < t < \infty$

$$X(0) = 0 \qquad t_b < t_a \Rightarrow X(t_b) \leq X(t_a)$$

$$P[X(t_a) - X(t_b) = k] = \frac{[\lambda(t_a - t_b)]^k}{k!} e^{-\lambda(t_a - t_b)}, \quad k = 0, 1, 2, \dots$$

$t_d < t_c \leq t_b < t_a \Rightarrow X(t_a) - X(t_b)$  &  $X(t_c) - X(t_d)$  are indep.

$$\bar{X}(t) = E[X(t)] = \lambda t \qquad R_{XX}(t, t) = E[X(t)^2] = \lambda t + (\lambda t)^2$$

$$C_{XX}(t, t) = \lambda t$$

# Poisson Random Process (contd..)



$$0 < t_1 < t_2 \Rightarrow$$

$$P[X(t_1) = k_1, X(t_2) = k_2] = P[X(t_1) = k_1, X(t_2) - X(t_1) = k_2 - k_1]$$

$$= \begin{cases} \frac{(\lambda t_1)^{k_1}}{k_1!} e^{-\lambda t_1} \frac{[\lambda(t_2 - t_1)]^{(k_2 - k_1)}}{(k_2 - k_1)!} e^{-\lambda(t_2 - t_1)}, & k_2 \geq k_1 \geq 0 \\ 0, & \text{otherwise} \end{cases}$$

$$= \begin{cases} \frac{(\lambda t_1)^{k_1} [\lambda(t_2 - t_1)]^{(k_2 - k_1)}}{k_1!(k_2 - k_1)!} e^{-\lambda t_2}, & k_2 \geq k_1 \geq 0 \\ 0, & \text{otherwise} \end{cases}$$

# Poisson Random Process (contd..)



$$0 < t_1 < t_2 \Rightarrow$$

$$\begin{aligned} P[X(t_2) = k_2 | X(t_1) = k_1] &= P[X(t_2) - X(t_1) = k_2 - k_1 | X(t_1) = k_1] \\ &= P[X(t_2) - X(t_1) = k_2 - k_1] \\ &= \begin{cases} \frac{[\lambda(t_2 - t_1)]^{(k_2 - k_1)}}{(k_2 - k_1)!} e^{-\lambda(t_2 - t_1)}, & k_2 \geq k_1 \\ 0, & \text{otherwise} \end{cases} \end{aligned}$$

# Example



$X(t) = \text{Poisson r.p.}$

$$0 < t_1 < t_2 < t_3$$

$$0 \leq k_1 \leq k_2 \leq k_3 \Rightarrow$$

$$\begin{aligned} & P[X(t_1) = k_1, X(t_2) = k_2, X(t_3) = k_3] \\ &= P[X(t_1) = k_1, X(t_2) - X(t_1) = k_2 - k_1, X(t_3) - X(t_2) = k_3 - k_2] \\ &= P[X(t_1) = k_1]P[X(t_2) - X(t_1) = k_2 - k_1]P[X(t_3) - X(t_2) = k_3 - k_2] \\ &= \frac{(\lambda t_1)^{k_1}}{k_1!} e^{-\lambda t_1} \frac{[\lambda(t_2 - t_1)]^{(k_2 - k_1)}}{(k_2 - k_1)!} e^{-\lambda(t_2 - t_1)} \frac{[\lambda(t_3 - t_2)]^{(k_3 - k_2)}}{(k_3 - k_2)!} e^{-\lambda(t_3 - t_2)} \\ &= \frac{(\lambda t_1)^{k_1} [\lambda(t_2 - t_1)]^{(k_2 - k_1)} [\lambda(t_3 - t_2)]^{(k_3 - k_2)}}{k_1!(k_2 - k_1)!(k_3 - k_2)!} e^{-\lambda t_3} \end{aligned}$$

# **MODULE-V**

## **Stochastic Processes: Spectral Characteristics**

# Introduction to Power density spectrum

- Fourier integral

$$x(t) = \frac{1}{2\pi} \int_{-\infty}^{\infty} \left[ \int_{-\infty}^{\infty} x(\tau) e^{-j\omega\tau} d\tau \right] e^{j\omega t} d\omega$$

- Fourier transform

$$X(\omega) = \int_{-\infty}^{\infty} x(t) e^{-j\omega t} dt$$

- Inverse Fourier transform

$$x(t) = \frac{1}{2\pi} \int_{-\infty}^{\infty} X(\omega) e^{j\omega t} d\omega$$



# Introduction (Contd..)



$$x_T(t) = \begin{cases} x(t), & -T < t < T \\ 0, & \text{o/w} \end{cases}$$

Assume  $\int_{-T}^T |x_T(t)| dt < \infty$ , for all finite  $T$ .

$$X_T(\omega) = \int_{-\infty}^{\infty} x_T(t) e^{-j\omega t} dt = \int_{-T}^T x(t) e^{-j\omega t} dt$$

□ Energy contained in  $x(t)$  in the interval  $(-T, T)$

$$E(T) = \int_{-\infty}^{\infty} x_T(t)^2 dt = \int_{-T}^T x(t)^2 dt = \frac{1}{2\pi} \int_{-\infty}^{\infty} |X_T(\omega)|^2 d\omega$$

# Introduction (Contd..)



- Average power in  $x(t)$  in the interval  $(-T, T)$

$$P(T) = \frac{1}{2T} \int_{-T}^T x(t)^2 dt = \frac{1}{2\pi} \int_{-\infty}^{\infty} \frac{|X_T(\omega)|^2}{2T} d\omega$$

$x(t) \rightarrow X(t)$ , take expectation, let  $T \rightarrow \infty$ .

- Average power in random process  $x(t)$

$$P_{XX} = \lim_{T \rightarrow \infty} \frac{1}{2T} \int_{-T}^T E[X(t)^2] dt = \frac{1}{2\pi} \int_{-\infty}^{\infty} \lim_{T \rightarrow \infty} \frac{E[|X_T(\omega)|^2]}{2T} d\omega$$

$$P_{XX} = A\{E[X(t)^2]\} \qquad P_{XX} = \frac{1}{2\pi} \int_{-\infty}^{\infty} S_{XX}(\omega) d\omega$$

$$S_{XX} = \lim_{T \rightarrow \infty} \frac{E[|X_T(\omega)|^2]}{2T} \quad \text{power density spectrum}$$

# Example-1



$$P_{XX} = A\{E[X(t)^2]\}$$

$$\text{w.s.s.} \Rightarrow P_{XX} = R_{XX}(0)$$

□ **Example-**  $X(t) = A_0 \cos(\omega_0 t + \Theta)$      $\Theta$  -- uniformly distributed on  $(0, \frac{\pi}{2})$   
1

$$\begin{aligned} E[X(t)^2] &= E[A_0^2 \cos^2(\omega_0 t + \Theta)] = E\left[\frac{A_0^2}{2} + \frac{A_0^2}{2} \cos(2\omega_0 t + 2\Theta)\right] \\ &= \frac{A_0^2}{2} + \frac{A_0^2}{2} \int_0^{\frac{\pi}{2}} \frac{2}{\pi} \cos(2\omega_0 t + 2\theta) d\theta = \frac{A_0^2}{2} + \frac{A_0^2}{2\pi} \sin(2\omega_0 t + 2\theta) \Big|_{\theta=0}^{\frac{\pi}{2}} \\ &= \frac{A_0^2}{2} - \frac{A_0^2}{\pi} \sin(2\omega_0 t) \end{aligned}$$

$$P_{XX} = A\{E[X(t)^2]\} = \lim_{T \rightarrow \infty} \frac{1}{2T} \int_{-T}^T \left[ \frac{A_0^2}{2} - \frac{A_0^2}{\pi} \sin(2\omega_0 t) \right] dt = \frac{A_0^2}{2}$$

# Example-2

□ Example-  $X(t) = A_0 \cos(\omega_0 t + \Theta)$

$$X_T(\omega) = \int_{-T}^T A_0 \cos(\omega_0 t + \Theta) e^{-j\omega t} dt = \int_{-T}^T A_0 \frac{1}{2} [e^{j\Theta} e^{j\omega_0 t} + e^{-j\Theta} e^{-j\omega_0 t}] e^{-j\omega t} dt$$

$$= \frac{A_0}{2} e^{j\Theta} \int_{-T}^T e^{j(\omega_0 - \omega)t} dt + \frac{A_0}{2} e^{-j\Theta} \int_{-T}^T e^{-j(\omega_0 + \omega)t} dt$$

$$= A_0 T e^{j\Theta} \frac{\sin[(\omega - \omega_0)T]}{(\omega - \omega_0)T} + A_0 T e^{-j\Theta} \frac{\sin[(\omega + \omega_0)T]}{(\omega + \omega_0)T}$$

$$\int_{-T}^T e^{j\beta t} dt = \frac{1}{j\beta} e^{j\beta t} \Big|_{t=-T}^T = \frac{e^{j\beta T} - e^{-j\beta T}}{j\beta} = 2T \frac{\sin(\beta T)}{\beta T}$$

$$S_{XX} = \lim_{T \rightarrow \infty} \frac{E[|X_T(\omega)|^2]}{2T} \quad \text{power density spectrum}$$

## Example-2 (Contd..)



$$X_T(\omega) = A_0 T e^{j\Theta} \frac{\sin[(\omega - \omega_0)T]}{(\omega - \omega_0)T} + A_0 T e^{-j\Theta} \frac{\sin[(\omega + \omega_0)T]}{(\omega + \omega_0)T}$$

$$X_T(\omega)^* = A_0 T e^{-j\Theta} \frac{\sin[(\omega - \omega_0)T]}{(\omega - \omega_0)T} + A_0 T e^{j\Theta} \frac{\sin[(\omega + \omega_0)T]}{(\omega + \omega_0)T}$$

$$\begin{aligned} |X_T(\omega)|^2 &= X_T(\omega) X_T(\omega)^* = A_0^2 \left[ T^2 \frac{\sin^2[(\omega - \omega_0)T]}{(\omega - \omega_0)^2 T^2} + T^2 \frac{\sin^2[(\omega + \omega_0)T]}{(\omega + \omega_0)^2 T^2} \right] \\ &\quad + A_0^2 T^2 (e^{j2\Theta} + e^{-j2\Theta}) \frac{\sin[(\omega - \omega_0)T]}{(\omega - \omega_0)T} \frac{\sin[(\omega + \omega_0)T]}{(\omega + \omega_0)T} \end{aligned}$$

$$E[e^{j2\Theta} + e^{-j2\Theta}] = E[2 \cos 2\Theta] = \int_0^{\pi/2} \frac{2}{\pi} 2 \cos 2\theta d\theta = \frac{2}{\pi} \sin 2\theta \Big|_0^{\pi/2} = 0$$

$$\frac{E[|X_T(\omega)|^2]}{2T} = \frac{A_0^2 \pi}{2} \left[ \frac{T}{\pi} \frac{\sin^2[(\omega - \omega_0)T]}{(\omega - \omega_0)^2 T^2} + \frac{T}{\pi} \frac{\sin^2[(\omega + \omega_0)T]}{(\omega + \omega_0)^2 T^2} \right]$$

## Example-2 (Contd..)

$$\int_{-\infty}^{\infty} \frac{\sin^2 x}{x^2} dx = \pi$$

$$\int_{-\infty}^{\infty} \frac{T \sin^2(\alpha T)}{\pi (\alpha T)^2} d\alpha = \int_{-\infty}^{\infty} \frac{T \sin^2 x}{\pi x^2} \frac{1}{T} dx = 1 \quad (\text{a})$$

$$\lim_{T \rightarrow \infty} \frac{T \sin^2(\alpha T)}{\pi (\alpha T)^2} = \begin{cases} \infty, & \text{if } \alpha = 0 \\ 0, & \text{if } \alpha \neq 0 \end{cases} \quad (\text{b})$$

$$(\text{a}) \ \& \ (\text{b}) \ \Rightarrow \ \lim_{T \rightarrow \infty} \frac{T \sin^2(\alpha T)}{\pi (\alpha T)^2} = \delta(\alpha)$$

$$S_{XX}(\omega) = \lim_{T \rightarrow \infty} \frac{E[|X_T(\omega)|^2]}{2T} = \frac{A_0^2 \pi}{2} [\delta(\omega - \omega_0) + \delta(\omega + \omega_0)]$$

$$P_{XX} = \frac{1}{2\pi} \int_{-\infty}^{\infty} S_{XX}(\omega) d\omega = \frac{1}{2\pi} \int_{-\infty}^{\infty} \frac{A_0^2 \pi}{2} [\delta(\omega - \omega_0) + \delta(\omega + \omega_0)] d\omega = \frac{A_0^2}{2}$$

# Properties Power density spectrum



Properties of the power density spectrum:

$$(1) \quad S_{XX}(\omega) \geq 0$$

$$(2) \quad X(t) \text{ real} \Rightarrow S_{XX}(-\omega) = S_{XX}(\omega)$$

$$(3) \quad S_{XX}(\omega) \text{ is real}$$

$$(4) \quad \frac{1}{2\pi} \int_{-\infty}^{\infty} S_{XX}(\omega) d\omega = A\{E[X(t)^2]\}$$

$$S_{XX}(\omega) = \lim_{T \rightarrow \infty} \frac{E[|X_T(\omega)|^2]}{2T}$$

$$\text{PF of (2):} \quad X_T(\omega) = \int_{-T}^T X(t) e^{-j\omega t} dt$$

$$X_T(\omega)^* = \int_{-T}^T X(t)^* e^{j\omega t} dt = \int_{-T}^T X(t) e^{j\omega t} dt = X_T(-\omega)$$

$$S_{XX}(-\omega) = \lim_{T \rightarrow \infty} \frac{E[X_T(-\omega) X_T(-\omega)^*]}{2T} = \lim_{T \rightarrow \infty} \frac{E[X_T(\omega)^* X_T(\omega)]}{2T} = S_{XX}(\omega)$$

# Properties Power density spectrum



Properties of the power density spectrum

$$(5) \quad S_{\dot{X}\dot{X}}(\omega) = \omega^2 S_{XX}(\omega) \quad \frac{d}{dt} X(t) = \lim_{\varepsilon \rightarrow 0} \frac{X(t+\varepsilon) - X(t)}{\varepsilon}$$

PF of (5):

$$\dot{X}_T(t) = \begin{cases} \lim_{\varepsilon \rightarrow 0} \frac{X(t+\varepsilon) - X(t)}{\varepsilon}, & -T < t < T \\ 0, & \text{o/w} \end{cases}$$

$$f(t-a) \xleftrightarrow{FT} F(\omega)e^{-j\omega a}$$

$$\dot{X}_T(t) \xleftrightarrow{FT} \lim_{\varepsilon \rightarrow 0} \frac{X_T(\omega)e^{j\omega\varepsilon} - X_T(\omega)}{\varepsilon} = j\omega X_T(\omega)$$

$$S_{\dot{X}\dot{X}}(\omega) = \lim_{T \rightarrow \infty} \frac{E[|\dot{X}_T(\omega)|^2]}{2T} = \lim_{T \rightarrow \infty} \frac{E[|j\omega X_T(\omega)|^2]}{2T} = \omega^2 \lim_{T \rightarrow \infty} \frac{E[|X_T(\omega)|^2]}{2T} = \omega^2 S_{XX}(\omega)$$



# Properties Power density spectrum



Bandwidth of the power density spectrum

$$X(t) \text{ real} \Rightarrow S_{XX}(\omega) \text{ even}$$

$$S_{XX}(\omega) \text{ lowpass form} \Rightarrow W_{\text{rms}}^2 = \frac{\int_{-\infty}^{\infty} \omega^2 S_{XX}(\omega) d\omega}{\int_{-\infty}^{\infty} S_{XX}(\omega) d\omega}$$

root mean square Bandwidth

$$S_{XX}(\omega) \text{ bandpass form} \Rightarrow \bar{\omega}_0 = \frac{\int_0^{\infty} \omega S_{XX}(\omega) d\omega}{\int_0^{\infty} S_{XX}(\omega) d\omega} \quad \text{mean frequency}$$

$$W_{\text{rms}}^2 = \frac{4 \int_0^{\infty} (\omega - \bar{\omega}_0)^2 S_{XX}(\omega) d\omega}{\int_0^{\infty} S_{XX}(\omega) d\omega} \quad \text{rms BW}$$

# Example



$$S_{XX}(\omega) = \frac{10}{[1+(\omega/10)^2]^2} \quad S_{XX}(\omega) \text{ lowpass form}$$

$$\begin{aligned} \int_{-\infty}^{\infty} S_{XX}(\omega) d\omega &= \int_{-\infty}^{\infty} \frac{10}{[1+(\omega/10)^2]^2} d\omega = \int_{-\pi/2}^{\pi/2} \frac{10}{[1+\tan^2 \theta]^2} 10 \sec^2 \theta d\theta \\ &= \int_{-\pi/2}^{\pi/2} \frac{100}{\sec^2 \theta} d\theta = \int_{-\pi/2}^{\pi/2} 100 \cos^2 \theta d\theta = \int_{-\pi/2}^{\pi/2} 100 \frac{1+\cos 2\theta}{2} d\theta = 50\pi \end{aligned}$$

$$\omega = 10 \tan \theta \Rightarrow d\omega = 10 \sec^2 \theta d\theta$$

$$\begin{aligned} \int_{-\infty}^{\infty} \omega^2 S_{XX}(\omega) d\omega &= \int_{-\infty}^{\infty} \frac{10\omega^2}{[1+(\omega/10)^2]^2} d\omega = \int_{-\pi/2}^{\pi/2} \frac{10^3 \tan^2 \theta}{[1+\tan^2 \theta]^2} 10 \sec^2 \theta d\theta \\ &= \int_{-\pi/2}^{\pi/2} \frac{10^4 \tan^2 \theta}{\sec^2 \theta} d\theta = \int_{-\pi/2}^{\pi/2} 10^4 \sin^2 \theta d\theta = \int_{-\pi/2}^{\pi/2} 10^4 \frac{1-\cos 2\theta}{2} d\theta = 5000\pi \end{aligned}$$

# Example



$$W_{\text{rms}}^2 = \frac{\int_{-\infty}^{\infty} \omega^2 S_{XX}(\omega) d\omega}{\int_{-\infty}^{\infty} S_{XX}(\omega) d\omega} = 100$$

rms BW  $W_{\text{rms}} = 10 \text{ rad/sec}$

$$S_{XX}(\omega) = \frac{10}{[1 + (\omega/10)^2]^2}$$

# Relationship between PSD and autocorrelation



$$\frac{1}{2\pi} \int_{-\infty}^{\infty} S_{XX}(\omega) e^{j\omega\tau} d\omega = A[R_{XX}(t, t + \tau)]$$

$$S_{XX}(\omega) = \int_{-\infty}^{\infty} A[R_{XX}(t, t + \tau)] e^{-j\omega\tau} d\tau$$

$$S_{XX}(\omega) = \lim_{T \rightarrow \infty} \frac{E[X_T(\omega)^* X_T(\omega)]}{2T} = \lim_{T \rightarrow \infty} \frac{1}{2T} E\left[\int_{-T}^T X(t_1) e^{j\omega t_1} dt_1 \int_{-T}^T X(t_2) e^{-j\omega t_2} dt_2\right]$$

$$= \lim_{T \rightarrow \infty} \frac{1}{2T} \int_{-T}^T \int_{-T}^T E[X(t_1) X(t_2)] e^{j\omega(t_1 - t_2)} dt_2 dt_1$$

$$= \lim_{T \rightarrow \infty} \frac{1}{2T} \int_{-T}^T \int_{-T}^T R_{XX}(t_1, t_2) e^{j\omega(t_1 - t_2)} dt_2 dt_1$$

$$\frac{1}{2\pi} \int_{-\infty}^{\infty} S_{XX}(\omega) e^{j\omega\tau} d\omega = \frac{1}{2\pi} \int_{-\infty}^{\infty} \lim_{T \rightarrow \infty} \frac{1}{2T} \int_{-T}^T \int_{-T}^T R_{XX}(t_1, t_2) e^{j\omega(t_1 - t_2)} dt_2 dt_1 e^{j\omega\tau} d\omega$$

$$= \lim_{T \rightarrow \infty} \frac{1}{2T} \int_{-T}^T \int_{-T}^T R_{XX}(t_1, t_2) \frac{1}{2\pi} \int_{-\infty}^{\infty} e^{j\omega(\tau + t_1 - t_2)} d\omega dt_2 dt_1$$

# Relationship between PSD and autocorrelation



$$\delta(t) \xleftrightarrow{FT} 1$$
$$\int_{-\infty}^{\infty} \delta(t) e^{-j\omega t} dt = 1$$
$$\delta(t) = \frac{1}{2\pi} \int_{-\infty}^{\infty} e^{j\omega t} d\omega$$

$$\frac{1}{2\pi} \int_{-\infty}^{\infty} S_{XX}(\omega) e^{j\omega\tau} d\omega = \lim_{T \rightarrow \infty} \frac{1}{2T} \int_{-T}^T \int_{-T}^T R_{XX}(t_1, t_2) \delta(\tau + t_1 - t_2) dt_2 dt_1$$
$$= \lim_{T \rightarrow \infty} \frac{1}{2T} \int_{-T}^T R_{XX}(t_1, t_1 + \tau) dt_1 = \lim_{T \rightarrow \infty} \frac{1}{2T} \int_{-T}^T R_{XX}(t, t + \tau) dt$$
$$= A[R_{XX}(t, t + \tau)]$$

$$A[R_{XX}(t, t + \tau)] \xleftrightarrow{FT} S_{XX}(\omega)$$

$$S_{XX}(\omega) = \int_{-\infty}^{\infty} A[R_{XX}(t, t + \tau)] e^{-j\omega\tau} d\tau$$

# Relationship between PSD and autocorrelation



$$\square X(t) \text{ w.s.s.} \Rightarrow A[R_{XX}(t, t + \tau)] = R_{XX}(\tau)$$

$$R_{XX}(\tau) \xleftrightarrow{FT} S_{XX}(\omega)$$

$$S_{XX}(\omega) = \int_{-\infty}^{\infty} R_{XX}(\tau) e^{-j\omega\tau} d\tau$$

$$R_{XX}(\tau) = \frac{1}{2\pi} \int_{-\infty}^{\infty} S_{XX}(\omega) e^{j\omega\tau} d\omega$$

# Cross-power density spectrum



$$W(t) = X(t) + Y(t)$$

$$\begin{aligned} R_{WW}(t, t + \tau) &= E[W(t)W(t + \tau)] = E\{[X(t) + Y(t)][X(t + \tau) + Y(t + \tau)]\} \\ &= R_{XX}(t, t + \tau) + R_{YY}(t, t + \tau) + R_{XY}(t, t + \tau) + R_{YX}(t, t + \tau) \end{aligned}$$

$$S_{WW}(\omega) = S_{XX}(\omega) + S_{YY}(\omega) + F\{A[R_{XY}(t, t + \tau)]\} + F\{A[R_{YX}(t, t + \tau)]\}$$

# Cross-power density spectrum



$$x_T(t) = \begin{cases} x(t), & -T < t < T \\ 0, & o/w \end{cases} \quad y_T(t) = \begin{cases} y(t), & -T < t < T \\ 0, & o/w \end{cases}$$

Assume  $\int_{-T}^T |x_T(t)| dt < \infty$  &  $\int_{-T}^T |y_T(t)| dt < \infty$ , for all finite  $T$ .

$$x_T(t) \xleftrightarrow{\text{FT}} X_T(\omega) \quad y_T(t) \xleftrightarrow{\text{FT}} Y_T(\omega)$$

Cross Power contained in  $x(t), y(t)$  in the interval  $(-T, T)$

$$P_{XY}(T) = \frac{1}{2T} \int_{-\infty}^{\infty} x_T(t) y_T(t) dt = \frac{1}{2T} \int_{-T}^T x(t) y(t) dt = \frac{1}{2\pi} \int_{-\infty}^{\infty} \frac{X_T(\omega)^* Y_T(\omega)}{2T} d\omega$$

Parseval's theorem



# Cross-power density spectrum



average Cross Power contained in  $X(t), Y(t)$  in the interval  $(-T, T)$

$$\bar{P}_{XY}(T) = \frac{1}{2T} \int_{-T}^T R_{XY}(t, t) dt = \frac{1}{2\pi} \int_{-\infty}^{\infty} \frac{E[X_T(\omega)^* Y_T(\omega)]}{2T} d\omega$$

total average Cross Power contained in  $X(t), Y(t)$

$$P_{XY} = \lim_{T \rightarrow \infty} \frac{1}{2T} \int_{-T}^T R_{XY}(t, t) dt = \frac{1}{2\pi} \int_{-\infty}^{\infty} \lim_{T \rightarrow \infty} \frac{E[X_T(\omega)^* Y_T(\omega)]}{2T} d\omega$$

cross-power density spectrum  $S_{XY}(\omega) = \lim_{T \rightarrow \infty} \frac{E[X_T(\omega)^* Y_T(\omega)]}{2T}$

# Cross-power density spectrum



$$P_{XY} = \frac{1}{2\pi} \int_{-\infty}^{\infty} S_{XY}(\omega) d\omega$$

$$S_{YX}(\omega) = \lim_{T \rightarrow \infty} \frac{E[Y_T(\omega)^* X_T(\omega)]}{2T}$$

$$P_{YX} = \frac{1}{2\pi} \int_{-\infty}^{\infty} S_{YX}(\omega) d\omega = P_{XY}^*$$

$$\text{Total cross power} = P_{XY} + P_{YX}$$

$$X(t), Y(t) \text{ orthogonal} \Rightarrow P_{XY} = P_{YX} = 0$$

# Properties of cross-power density spectrum



$X(t), Y(t)$  real

Properties of the cross-power density spectrum:

$$(1) \quad S_{XY}(\omega) = S_{YX}(-\omega) = S_{YX}(\omega)^*$$

$$\text{PF of (1):} \quad X_T(\omega) = \int_{-T}^T X(t) e^{-j\omega t} dt$$

$$X_T(\omega)^* = \int_{-T}^T X(t)^* e^{j\omega t} dt = \int_{-T}^T X(t) e^{j\omega t} dt = X_T(-\omega)$$

$$S_{YX}(-\omega) = \lim_{T \rightarrow \infty} \frac{E[Y_T(-\omega)^* X_T(-\omega)]}{2T} = \lim_{T \rightarrow \infty} \frac{E[Y_T(\omega) X_T(\omega)^*]}{2T} = S_{XY}(\omega)$$

$$S_{YX}(-\omega) = \lim_{T \rightarrow \infty} \frac{E[Y_T(-\omega)^* X_T(-\omega)]}{2T} = \lim_{T \rightarrow \infty} \frac{E[Y_T(\omega) X_T(\omega)^*]}{2T} = S_{YX}(\omega)^*$$

# Properties of cross-power density spectrum



(2)  $\text{Re}[S_{XY}(\omega)]$  &  $\text{Re}[S_{YX}(\omega)]$  -- even

(3)  $\text{Im}[S_{XY}(\omega)]$  &  $\text{Im}[S_{YX}(\omega)]$  -- odd

$$A[R_{XY}(t, t + \tau)] \xleftrightarrow{FT} S_{XY}(\omega)$$

$$A[R_{YX}(t, t + \tau)] \xleftrightarrow{FT} S_{YX}(\omega)$$

(4)  $X(t)$  &  $Y(t)$  orthogonal  $\Rightarrow S_{XY}(\omega) = S_{YX}(\omega) = 0$

$$X(t) \text{ & } Y(t) \text{ orthogonal} \Rightarrow R_{XY}(t, t + \tau) = 0 \Rightarrow A[R_{XY}(t, t + \tau)] = 0$$

(5)  $X(t)$  &  $Y(t)$  uncorrelated & have constant mean  $\bar{X}, \bar{Y}$

$$\Rightarrow S_{XY}(\omega) = S_{YX}(\omega) = 2\pi \bar{X}\bar{Y} \delta(\omega)$$

# Properties of cross-power density spectrum



$$\text{PF of (5): } R_{XY}(t, t + \tau) = \overline{XY} \Rightarrow A[R_{XY}(t, t + \tau)] = \overline{XY}$$

$$\Rightarrow S_{XY}(\omega) = 2\pi \overline{XY} \delta(\omega) = S_{YX}(\omega)^*$$

$$X(t), Y(t) \text{ -- jointly w.s.s. } \Rightarrow R_{XY}(\tau) \xleftrightarrow{\text{FT}} S_{XY}(\omega)$$

$$R_{YX}(\tau) \xleftrightarrow{\text{FT}} S_{YX}(\omega)$$

# Relationship between C-PSD and cross-correlation



$$\frac{1}{2\pi} \int_{-\infty}^{\infty} S_{XY}(\omega) e^{j\omega\tau} d\omega = A[R_{XY}(t, t + \tau)]$$

$$S_{XY}(\omega) = \int_{-\infty}^{\infty} A[R_{XY}(t, t + \tau)] e^{-j\omega\tau} d\tau$$

$$S_{XY}(\omega) = \lim_{T \rightarrow \infty} \frac{E[X_T(\omega)^* Y_T(\omega)]}{2T} = \lim_{T \rightarrow \infty} \frac{1}{2T} E\left[\int_{-T}^T X(t_1) e^{j\omega t_1} dt_1 \int_{-T}^T Y(t_2) e^{-j\omega t_2} dt_2\right]$$

$$= \lim_{T \rightarrow \infty} \frac{1}{2T} \int_{-T}^T \int_{-T}^T E[X(t_1) Y(t_2)] e^{j\omega(t_1 - t_2)} dt_2 dt_1$$

$$= \lim_{T \rightarrow \infty} \frac{1}{2T} \int_{-T}^T \int_{-T}^T R_{XY}(t_1, t_2) e^{j\omega(t_1 - t_2)} dt_2 dt_1$$

$$\frac{1}{2\pi} \int_{-\infty}^{\infty} S_{XY}(\omega) e^{j\omega\tau} d\omega = \frac{1}{2\pi} \int_{-\infty}^{\infty} \lim_{T \rightarrow \infty} \frac{1}{2T} \int_{-T}^T \int_{-T}^T R_{XY}(t_1, t_2) e^{j\omega(t_1 - t_2)} dt_2 dt_1 e^{j\omega\tau} d\omega$$

$$= \lim_{T \rightarrow \infty} \frac{1}{2T} \int_{-T}^T \int_{-T}^T R_{XY}(t_1, t_2) \frac{1}{2\pi} \int_{-\infty}^{\infty} e^{j\omega(\tau + t_1 - t_2)} d\omega dt_2 dt_1$$

# Relationship between C-PSD and cross-correlation



$$\delta(t) \xleftrightarrow{FT} 1 \quad \int_{-\infty}^{\infty} \delta(t) e^{-j\omega t} dt = 1$$
$$\delta(t) = \frac{1}{2\pi} \int_{-\infty}^{\infty} e^{j\omega t} d\omega$$

$$\begin{aligned} \frac{1}{2\pi} \int_{-\infty}^{\infty} S_{XY}(\omega) e^{j\omega\tau} d\omega &= \lim_{T \rightarrow \infty} \frac{1}{2T} \int_{-T}^T \int_{-T}^T R_{XY}(t_1, t_2) \delta(\tau + t_1 - t_2) dt_2 dt_1 \\ &= \lim_{T \rightarrow \infty} \frac{1}{2T} \int_{-T}^T R_{XY}(t_1, t_1 + \tau) dt_1 = \lim_{T \rightarrow \infty} \frac{1}{2T} \int_{-T}^T R_{XY}(t, t + \tau) dt \\ &= A[R_{XY}(t, t + \tau)] \end{aligned}$$

$$A[R_{XY}(t, t + \tau)] \xleftrightarrow{FT} S_{XY}(\omega)$$

$$S_{XY}(\omega) = \int_{-\infty}^{\infty} A[R_{XY}(t, t + \tau)] e^{-j\omega\tau} d\tau$$

# Example



Example:

$$R_{XY}(t, t + \tau) = \frac{AB}{2} \{ \sin(\omega_0 \tau) + \cos[\omega_0(2t + \tau)] \}$$

$$A[R_{XY}(t, t + \tau)] = \lim_{T \rightarrow \infty} \frac{1}{2T} \int_{-T}^T R_{XY}(t, t + \tau) dt$$

$$= \frac{AB}{2} \sin(\omega_0 \tau) + \frac{AB}{2} \lim_{T \rightarrow \infty} \frac{1}{2T} \int_{-T}^T \cos[\omega_0(2t + \tau)] dt$$

$$= \frac{AB}{2} \sin(\omega_0 \tau) = \frac{AB}{4j} [e^{j\omega_0 \tau} - e^{-j\omega_0 \tau}]$$

$$S_{XY}(\omega) = \frac{AB}{4j} [2\pi\delta(\omega - \omega_0) - 2\pi\delta(\omega + \omega_0)] = \frac{-j\pi AB}{2} [\delta(\omega - \omega_0) - \delta(\omega + \omega_0)]$$



# Linear system fundamentals



Linear System

$$y(t) = \int_{-\infty}^{\infty} x(\xi)h(t, \xi)d\xi$$

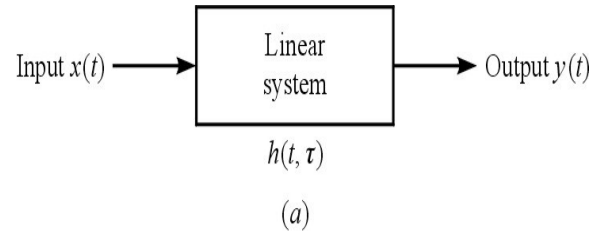

$$\delta(t - \xi) \rightarrow h(t, \xi)$$

impulse response

Linear Time-Invariant System (LTI system)

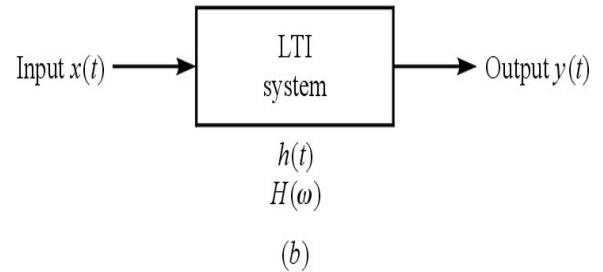

$$y(t) = \int_{-\infty}^{\infty} x(\xi)h(t - \xi)d\xi = \int_{-\infty}^{\infty} h(\xi)x(t - \xi)d\xi$$

$$y(t) = x(t) * h(t) = h(t) * x(t) \quad \text{convolution integral}$$

$$Y(\omega) = X(\omega)H(\omega)$$

$$x(t) = e^{j\omega t} \Rightarrow \frac{y(t)}{x(t)} = \frac{\int_{-\infty}^{\infty} h(\xi)e^{j\omega(t-\xi)} d\xi}{e^{j\omega t}} = \int_{-\infty}^{\infty} h(\xi)e^{-j\omega\xi} d\xi = H(\omega)$$

# Linear system fundamentals

Example-1: 
$$H(s) = \frac{R}{sL + R}$$

$$H(\omega) = \frac{R}{j\omega L + R}$$

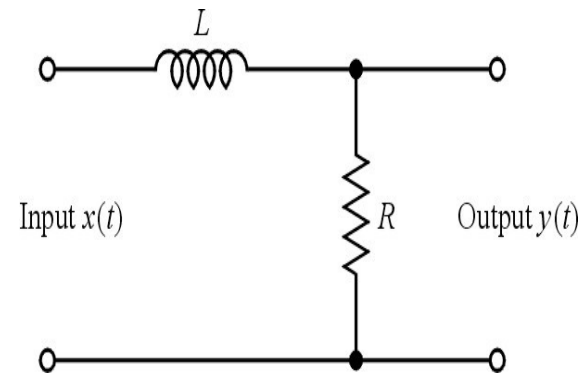

LTI      causal     $\Leftrightarrow$   $h(t) = 0$  for  $t < 0$

LTI      stable     $\Leftrightarrow$   $\int_{-\infty}^{\infty} |h(t)| dt < \infty$

# Linear system fundamentals

## Ideal lowpass filter

$$H(\omega) = \begin{cases} e^{-jt_0\omega}, & |\omega| < W \\ 0, & \text{o/w} \end{cases}$$

$$h(t) = \frac{1}{2\pi} \int_{-W}^W e^{-jt_0\omega} e^{j\omega t} d\omega = \frac{1}{2\pi} \int_{-W}^W e^{j(t-t_0)\omega} d\omega$$

$$= \frac{1}{2\pi} \frac{1}{j(t-t_0)} e^{j(t-t_0)\omega} \Big|_{-W}^W$$

$$= \frac{1}{2\pi} \frac{e^{j(t-t_0)W} - e^{-j(t-t_0)W}}{j(t-t_0)}$$

$$= \frac{W \sin[(t-t_0)W]}{\pi (t-t_0)W}$$

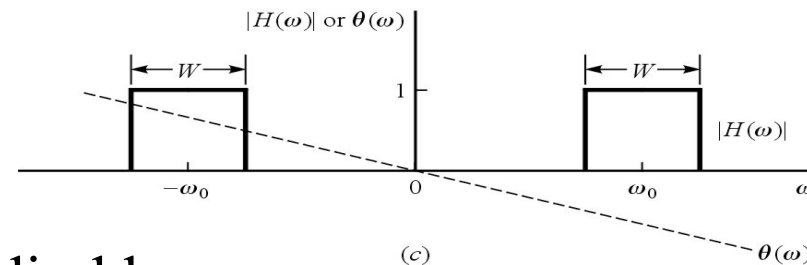
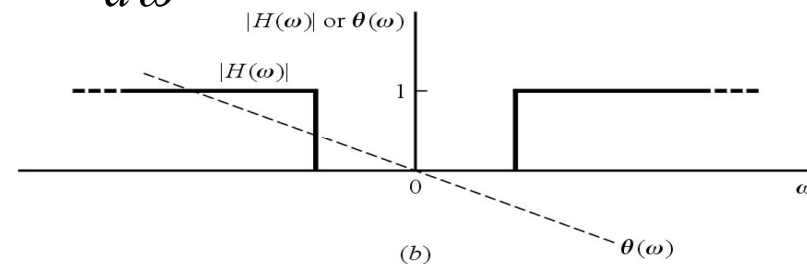
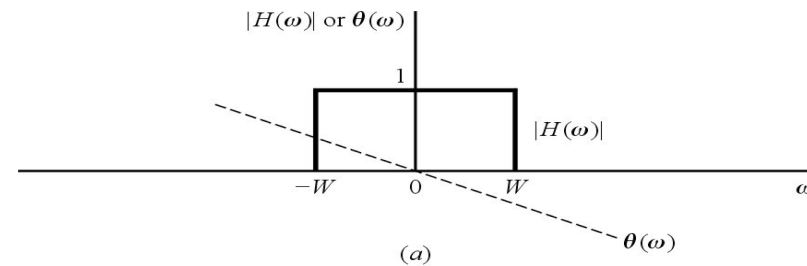

Not causal  $\Rightarrow$  Not physically realizable

# Random signal response of linear systems



$$X(t) \quad \text{-- w.s.s. random input} \qquad Y(t) = \int_{-\infty}^{\infty} h(\xi)X(t-\xi)d\xi$$

$$\begin{aligned} E[Y(t)] &= E\left[\int_{-\infty}^{\infty} h(\xi)X(t-\xi)d\xi\right] = \int_{-\infty}^{\infty} h(\xi)E[X(t-\xi)]d\xi \\ &= \bar{X} \int_{-\infty}^{\infty} h(\xi)d\xi = \bar{Y} \end{aligned}$$

$$\begin{aligned} R_{YY}(t, t+\tau) &= E[Y(t)Y(t+\tau)] \\ &= E\left[\int_{-\infty}^{\infty} h(\xi_1)X(t-\xi_1)d\xi_1 \int_{-\infty}^{\infty} h(\xi_2)X(t+\tau-\xi_2)d\xi_2\right] \\ &= \int_{-\infty}^{\infty} \int_{-\infty}^{\infty} E[X(t-\xi_1)X(t+\tau-\xi_2)]h(\xi_1)h(\xi_2)d\xi_1d\xi_2 \\ &= \int_{-\infty}^{\infty} \int_{-\infty}^{\infty} R_{XX}(\tau+\xi_1-\xi_2)h(\xi_1)h(\xi_2)d\xi_1d\xi_2 \end{aligned}$$

$$X(t) \text{ w.s.s.} \quad \Rightarrow \quad Y(t) \text{ w.s.s.}$$

# Random signal response of linear systems



$$\begin{aligned}R_{YY}(\tau) &= \int_{-\infty}^{\infty} \left[ \int_{-\infty}^{\infty} R_{XX}(\tau + \xi_1 - \xi_2) h(\xi_1) d\xi_1 \right] h(\xi_2) d\xi_2 \\&= \int_{-\infty}^{\infty} \left[ \int_{-\infty}^{\infty} R_{XX}(\tau - \xi_2 - \xi_1) h(-\xi_1) d\xi_1 \right] h(\xi_2) d\xi_2 \\&= \int_{-\infty}^{\infty} R_{XX}(\xi_1) * h(-\xi_1) \Big|_{\xi_1=\tau-\xi_2} h(\xi_2) d\xi_2 \\&= R_{XX}(\tau) * h(-\tau) * h(\tau)\end{aligned}$$

$$E[Y(t)^2] = \int_{-\infty}^{\infty} \int_{-\infty}^{\infty} R_{XX}(\xi_1 - \xi_2) h(\xi_1) h(\xi_2) d\xi_1 d\xi_2$$

Example-1: white noise  $X(t)$

$$R_{XX}(\tau) = (N_0/2)\delta(\tau)$$

$$\begin{aligned}E[Y(t)^2] &= \int_{-\infty}^{\infty} \int_{-\infty}^{\infty} (N_0/2)\delta(\xi_1 - \xi_2) h(\xi_1) h(\xi_2) d\xi_1 d\xi_2 \\&= (N_0/2) \int_{-\infty}^{\infty} h(\xi_2)^2 d\xi_2\end{aligned}$$

# Random signal response of linear systems



$$\begin{aligned}R_{XY}(t, t + \tau) &= E[X(t)Y(t + \tau)] = E\left[X(t) \int_{-\infty}^{\infty} h(\xi) X(t + \tau - \xi) d\xi\right] \\&= \int_{-\infty}^{\infty} E[X(t)X(t + \tau - \xi)] h(\xi) d\xi \\&= \int_{-\infty}^{\infty} R_{XX}(\tau - \xi) h(\xi) d\xi \\&= R_{XX}(\tau) * h(\tau) = R_{XY}(\tau)\end{aligned}$$

$$\begin{aligned}R_{YX}(\tau) &= R_{XY}(-\tau) = R_{XX}(-\tau) * h(-\tau) = R_{XX}(\tau) * h(-\tau) \\&= \int_{-\infty}^{\infty} R_{XX}(\tau - \xi) h(-\xi) d\xi\end{aligned}$$

$X(t)$  w.s.s.  $\Rightarrow X(t)$  &  $Y(t)$  jointly w.s.s.

$$R_{YY}(\tau) = R_{XY}(\tau) * h(-\tau) = R_{YX}(\tau) * h(\tau)$$

# Random signal response of linear systems



Example-2: white noise  $X(t)$        $R_{XX}(\tau) = (N_0/2)\delta(\tau)$

$$\begin{aligned} R_{XY}(\tau) &= R_{XX}(\tau) * h(\tau) = \int_{-\infty}^{\infty} R_{XX}(\tau - \xi)h(\xi)d\xi \\ &= \int_{-\infty}^{\infty} (N_0/2)\delta(\tau - \xi)h(\xi)d\xi = (N_0/2)h(\tau) \end{aligned}$$

$$R_{YX}(\tau) = R_{XY}(-\tau) = (N_0/2)h(-\tau)$$

# Spectral characteristics of system response



$$R_{XY}(\tau) = R_{XX}(\tau) * h(\tau) \qquad S_{XY}(\omega) = S_{XX}(\omega)H(\omega)$$

$$R_{YX}(\tau) = R_{XX}(\tau) * h(-\tau) \qquad S_{YX}(\omega) = S_{XX}(\omega)H(-\omega) = S_{XX}(\omega)H(\omega)^*$$

$$R_{YY}(\tau) = R_{XY}(\tau) * h(-\tau) = R_{XX}(\tau) * h(\tau) * h(-\tau)$$

$$S_{YY}(\omega) = S_{XY}(\omega)H(\omega)^* = S_{XX}(\omega)H(\omega)H(\omega)^* = S_{XX}(\omega)|H(\omega)|^2$$

$$h(\tau) \xleftrightarrow{FT} H(\omega)$$

$$h(\tau) \text{ real} \Rightarrow h(-\tau) \xleftrightarrow{FT} H(-\omega) = H(\omega)^*$$



# Spectral characteristics of system response



average power  $P_{YY} = \frac{1}{2\pi} \int_{-\infty}^{\infty} S_{YY}(\omega) d\omega = \frac{1}{2\pi} \int_{-\infty}^{\infty} S_{XX}(\omega) |H(\omega)|^2 d\omega$

Example-1:  $S_{XX}(\omega) = \frac{N_0}{2}$   $H(\omega) = \frac{1}{1 + (j\omega L/R)}$

$$S_{YY}(\omega) = S_{XX}(\omega) |H(\omega)|^2 = \frac{N_0/2}{1 + (\omega L/R)^2}$$

$$\begin{aligned} P_{YY} &= \frac{1}{2\pi} \int_{-\infty}^{\infty} S_{YY}(\omega) d\omega = \frac{N_0}{4\pi} \int_{-\infty}^{\infty} \frac{1}{1 + (\omega L/R)^2} d\omega \\ &= \frac{N_0}{4\pi} \int_{-\pi/2}^{\pi/2} \frac{1}{1 + \tan^2 \theta} \frac{R}{L} \sec^2 \theta d\theta = \frac{N_0 R}{4\pi L} \int_{-\pi/2}^{\pi/2} d\theta = \frac{N_0 R}{4L} \end{aligned}$$

# Spectral characteristics of system response



$$h(t) = (R/L)u(t)e^{-Rt/L} \quad \xleftrightarrow{FT} \quad H(\omega) = \frac{1}{1 + (j\omega L/R)}$$

By Example-1,

$$P_{YY} = \frac{N_0}{2} \int_{-\infty}^{\infty} h(t)^2 dt = \frac{N_0}{2} \int_0^{\infty} (R/L)^2 e^{-2Rt/L} dt = \frac{N_0 R}{4L} e^{-2Rt/L} \Big|_0^{\infty} = \frac{N_0 R}{4L}$$

# Random process through a LTI System

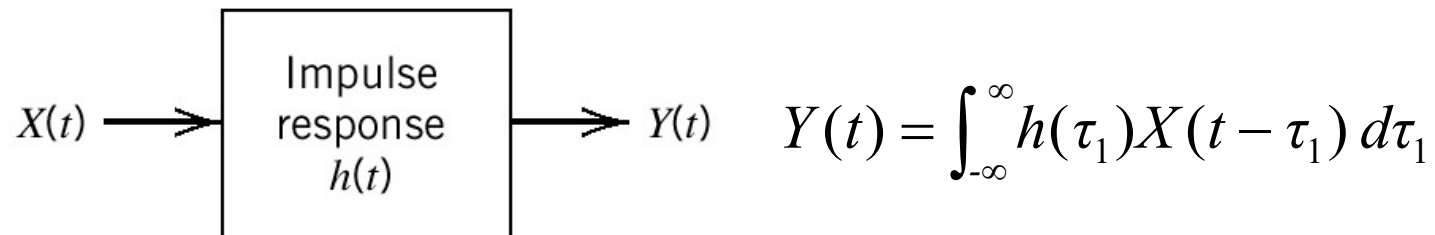

where  $h(t)$  is the impulse response of the system

$$\mu_Y(t) = E[Y(t)]$$

If  $E[X(t)]$  is finite

and system is stable

$$= E \left[ \int_{-\infty}^{\infty} h(\tau_1) X(t - \tau_1) d\tau_1 \right]$$

$$= \int_{-\infty}^{\infty} h(\tau_1) E[x(t - \tau_1)] d\tau_1$$

If  $X(t)$  is stationary,

$H(0)$  : System DC response.

$$= \int_{-\infty}^{\infty} h(\tau_1) \mu_X(t - \tau_1) d\tau_1$$

$$\mu_Y = \mu_X \int_{-\infty}^{\infty} h(\tau_1) d\tau_1 = \mu_X H(0),$$

# Random process through a LTI System



Consider autocorrelation function of  $Y(t)$ :

$$R_Y(t, \mu) = E [Y(t)Y(\mu)]$$
$$= E \left[ \int_{-\infty}^{\infty} h(\tau_1)X(t - \tau_1) d\tau_1 \int_{-\infty}^{\infty} h(\tau_2)X(\mu - \tau_2) d\tau_2 \right]$$

If  $E[X^2(t)]$  is finite and the system is stable,

$$R_Y(t, \mu) = \int_{-\infty}^{\infty} d\tau_1 h(\tau_1) \int_{-\infty}^{\infty} d\tau_2 h(\tau_2) R_X(t - \tau_1, \mu - \tau_2)$$

If  $R_X(t - \tau_1, \mu - \tau_2) = R_X(t - \mu - \tau_1 + \tau_2)$  (stationary)

$$R_Y(\tau) = \int_{-\infty}^{\infty} \int_{-\infty}^{\infty} h(\tau_1)h(\tau_2)R_X(\tau - \tau_1 + \tau_2) d\tau_1 d\tau_2$$

Stationary input, Stationary output

$$R_Y(0) = E [Y^2(t)] = \int_{-\infty}^{\infty} \int_{-\infty}^{\infty} h(\tau_1)h(\tau_2)R_X(\tau_2 - \tau_1) d\tau_1 d\tau_2$$

# Power Spectral Density (PSD)



Consider the Fourier transform of  $g(t)$ ,

$$G(f) = \int_{-\infty}^{\infty} g(t) \exp(-j2\pi ft) dt$$

$$g(t) = \int_{-\infty}^{\infty} G(f) \exp(j2\pi ft) df$$

Let  $H(f)$  denote the frequency response,

$$\tau = \tau_2 - \tau_1$$

$$h(\tau_1) = \int_{-\infty}^{\infty} H(f) \exp(j2\pi f\tau_1) df$$

$$E[Y^2(t)] = \int_{-\infty}^{\infty} \int_{-\infty}^{\infty} \left[ \int_{-\infty}^{\infty} H(f) \exp(j2\pi f\tau_1) df \right] h(\tau_2) R_X(\tau_2 - \tau_1) d\tau_1 d\tau_2$$

$$= \int_{-\infty}^{\infty} df H(f) \int_{-\infty}^{\infty} d\tau_2 h(\tau_2) \int_{-\infty}^{\infty} R_X(\tau_2 - \tau_1) \exp(j2\pi f\tau_1) d\tau_1$$

$$= \int_{-\infty}^{\infty} df H(f) \int_{-\infty}^{\infty} d\tau_2 h(\tau_2) \exp(j2\pi f\tau_2) \int_{-\infty}^{\infty} R_X(\tau) \exp(-j2\pi f\tau) d\tau$$

$H^*(f)$  (complex conjugate response of the filter)

# Power Spectral Density (PSD)



$$E[Y^2(t)] = \int_{-\infty}^{\infty} df |H(f)|^2 \int_{-\infty}^{\infty} R_X(\tau) \exp(-j2\pi f \tau) d\tau$$

$|H(f)|$  : the magnitude response  $S_X(f) = \int_{-\infty}^{\infty} R_X(\tau) \exp(-2\pi f \tau) d\tau$

$$E[Y^2(t)] = \int_{-\infty}^{\infty} |H(f)|^2 S_X(f) df$$

Define: Power Spectral Density ( Fourier Transform of  $R(\tau)$ )

$$E[Y^2(t)] = \int_{-\infty}^{\infty} \int_{-\infty}^{\infty} h(\tau_1) R_X(\tau_2 - \tau_1) d\tau_1 d\tau_2$$

Recall  $|H(f)| = \begin{cases} 1, & |f \pm f_c| < \frac{1}{2} \Delta f \\ 0, & |f \pm f_c| > \frac{1}{2} \Delta f \end{cases}$

Let  $|H(f)|$  be the magnitude response of an ideal narrowband filter

$\Delta f$  : Filter Bandwidth

If  $\Delta f \ll f_c$  and  $S_X(f)$  is continuous,

$$E[Y^2(t)] \approx 2\Delta f S_X(f_c) \text{ in W/Hz}$$

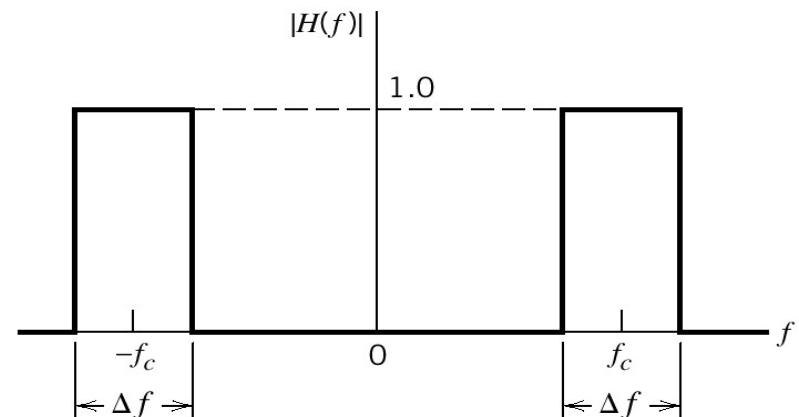

# The PSD of the Input and Output Random Processes

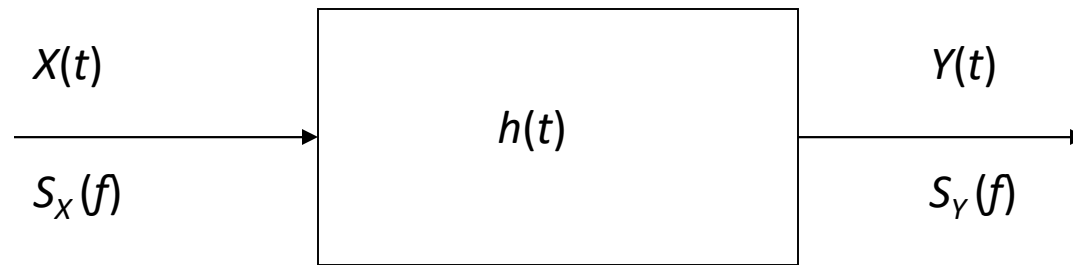

$$R_Y(\tau) = \int_{-\infty}^{\infty} \int_{-\infty}^{\infty} h(\tau_1)h(\tau_2)R_X(\tau - \tau_1 + \tau_2) d\tau_1 d\tau_2$$

$$S_Y(f) = \int_{-\infty}^{\infty} \int_{-\infty}^{\infty} \int_{-\infty}^{\infty} h(\tau_1)h(\tau_2)R_X(\tau - \tau_1 + \tau_2) \exp(-j2\pi f\tau) d\tau_1 d\tau_2 d\tau$$

Let  $\tau - \tau_1 + \tau_2 = \tau_0$  , or  $\tau = \tau_0 + \tau_1 - \tau_2$

$$\begin{aligned} S_Y(f) &= \int_{-\infty}^{\infty} \int_{-\infty}^{\infty} \int_{-\infty}^{\infty} h(\tau_1)h(\tau_2)R_X(\tau_1) \exp(j2\pi f\tau_0) \exp(-j2\pi f\tau_2) \exp(-j2\pi f\tau_0) d\tau_1 d\tau_2 d\tau_0 \\ &= S_X(f)H(f)H^*(f) \\ &= |H(f)|^2 S_X(f) \end{aligned}$$

# Relation Among The PSD and The Magnitude Spectrum of a Sample Function



Let  $x(t)$  be a sample function of a stationary and ergodic Process  $X(t)$ .  
In general, the condition for Fourier transformable is

$$\int_{-\infty}^{\infty} |x(t)| dt < \infty$$

This condition can never be satisfied by any stationary  $x(t)$  with infinite duration.

We may write  $X(f, T) = \int_{-T}^T x(t) \exp(-j2\pi ft) dt$

Ergodic  $\Rightarrow$  Take time average

$$R_X(\tau) = \lim_{T \rightarrow \infty} \frac{1}{2T} \int_{-T}^T x(t + \tau)x(t) dt$$

If  $x(t)$  is a power signal (finite average power)

$$\frac{1}{2T} \int_{-T}^T x(t + \tau)x(t) dt \Leftrightarrow \frac{1}{2T} |X(f, T)|^2$$

Time-averaged autocorrelation      periodogram function



# Relation Among The PSD and The Magnitude Spectrum of a Sample Function



Take inverse Fourier Transform

$$\frac{1}{2\pi} \int_{-T}^T x(t + \tau)x(t)dt = \int_{-\infty}^{\infty} \frac{1}{2T} |X(f, T)|^2 \exp(j2\pi fT)df$$

we have

$$R_X(\tau) = \lim_{T \rightarrow \infty} \int_{-\infty}^{\infty} \frac{1}{2T} |X(f, T)|^2 \exp(j2\pi f\tau)df$$

Note that for any given  $x(t)$  periodogram does not converge as  $T \rightarrow \infty$

Since  $x(t)$  is ergodic

$$E[R_X(\tau)] = R_X(\tau) = \lim_{T \rightarrow \infty} \int_{-\infty}^{\infty} \frac{1}{2T} E[|X(f - T)|^2] \exp(j2\pi f\tau)df$$

$$R_X(\tau) = \int_{-\infty}^{\infty} \left\{ \lim_{T \rightarrow \infty} \frac{1}{2T} E[|X(f - T)|^2] \right\} \exp(j2\pi f\tau)df$$

$$R_X(\tau) = \int_{-\infty}^{\infty} S_X(f) \exp(j2\pi f\tau)df$$

$$S_X(f) = \lim_{T \rightarrow \infty} \frac{1}{2T} E[|X(f, T)|^2]$$

is used to estimate the PSD of  $x(t)$

$$= \lim_{T \rightarrow \infty} \frac{1}{2T} E \left[ \left| \int_{-T}^T x(t) \exp(-j2\pi ft) dt \right|^2 \right]$$

# Cross-Spectral Densities



$$S_{XY}(f) = \int_{-\infty}^{\infty} R_{XY}(\tau) \exp(-j2\pi f\tau) d\tau$$

$$S_{YX}(f) = \int_{-\infty}^{\infty} R_{YX}(\tau) \exp(-j2\pi f\tau) d\tau$$

$S_{XY}(f)$  and  $S_{YX}(f)$  may not be real.

$$R_{XY}(\tau) = \int_{-\infty}^{\infty} S_{XY}(f) \exp(j2\pi f\tau) df$$

$$R_{YX}(\tau) = \int_{-\infty}^{\infty} S_{YX}(f) \exp(j2\pi f\tau) df$$

$$\therefore R_{XY}(\tau) = R_{YX}(-\tau)$$

$$S_{XY}(f) = S_{YX}(-f) = S_{YX}^*(f)$$

# Cross-Spectral Densities Example

Example:  $X(t)$  and  $Y(t)$  are jointly stationary.

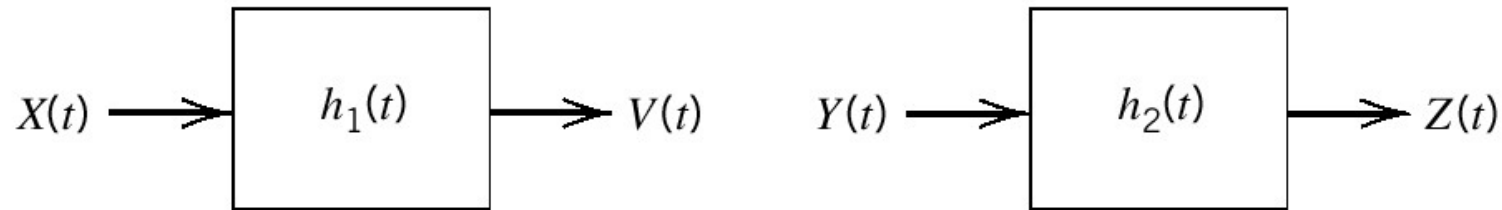

$$\begin{aligned} R_{VZ}(t, u) &= E[V(t)Z(u)] \\ &= E\left[\int_{-\infty}^{\infty} h_1(\tau_1)X(t-\tau_1)d\tau_1 \int_{-\infty}^{\infty} h_2(\tau_2)Y(u-\tau_2)d\tau_2\right] \\ &= \int_{-\infty}^{\infty} \int_{-\infty}^{\infty} h_1(\tau_1)h_2(\tau_2)R_{XY}(t-\tau_1, u-\tau_2)d\tau_1d\tau_2 \end{aligned}$$

Let  $\tau = t - u$

$$R_{VZ}(\tau) = \int_{-\infty}^{\infty} \int_{-\infty}^{\infty} h_1(\tau_1)h_2(\tau_2)R_{XY}(\tau - \tau_1 + \tau_2)d\tau_1d\tau_2$$

$$\xrightarrow{F} S_{VZ}(f) = H_1(f)H_2^*(f)S_{XY}(f)$$

# Cross-Spectral Densities



**Output Statistics:** the mean of the output process

is given by

$$\begin{aligned}\mu_Y(t) &= E\{Y(t)\} = \int_{-\infty}^{+\infty} E\{X(\tau)h(t-\tau)d\tau\} \\ &= \int_{-\infty}^{+\infty} \mu_X(\tau)h(t-\tau)d\tau = \mu_X(t) * h(t).\end{aligned}$$

Similarly the cross-correlation function between the input and output processes is given by

$$\begin{aligned}R_{XY}(t_1, t_2) &= E\{X(t_1)Y^*(t_2)\} \\ &= E\{X(t_1)\int_{-\infty}^{+\infty} X^*(t_2 - \alpha)h^*(\alpha)d\alpha\} \\ &= \int_{-\infty}^{+\infty} E\{X(t_1)X^*(t_2 - \alpha)\}h^*(\alpha)d\alpha \\ &= \int_{-\infty}^{+\infty} R_{XX}(t_1, t_2 - \alpha)h^*(\alpha)d\alpha \\ &= R_{XX}(t_1, t_2) * h^*(t_2).\end{aligned}$$

Finally the output autocorrelation function is given by

# Cross-Spectral Densities

$$\begin{aligned}
 R_{YY}(t_1, t_2) &= E\{Y(t_1)Y^*(t_2)\} \\
 &= E\left\{\int_{-\infty}^{+\infty} X(t_1 - \beta)h(\beta)d\beta Y^*(t_2)\right\} \\
 &= \int_{-\infty}^{+\infty} E\{X(t_1 - \beta)Y^*(t_2)\}h(\beta)d\beta \\
 &= \int_{-\infty}^{+\infty} R_{XY}(t_1 - \beta, t_2)h(\beta)d\beta \\
 \text{or} \\
 &= R_{XY}(t_1, t_2) * h(t_1),
 \end{aligned}$$

$$R_{YY}(t_1, t_2) = R_{XX}(t_1, t_2) * h^*(t_2) * h(t_1).$$

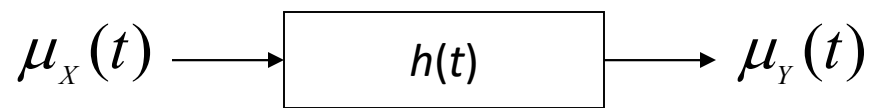

(a)

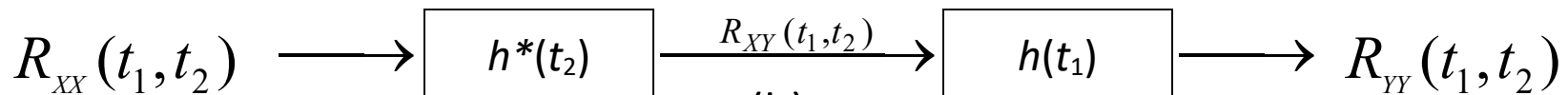

(b)

# Cross-Spectral Densities



In particular if  $X(t)$  is wide-sense stationary, then we have  $\mu_X(t) = \mu_X$  so that  $\mu_Y(t) = \mu_X \int_{-\infty}^{+\infty} h(\tau) d\tau = \mu_X c$ , a constant.

Also  $R_{XX}(t_1, t_2) = R_{XX}(t_1 - t_2)$  so that reduces to

$$\begin{aligned} R_{XY}(t_1, t_2) &= \int_{-\infty}^{+\infty} R_{XX}(t_1 - t_2 + \alpha) h^*(\alpha) d\alpha \\ &= R_{XX}(\tau) * h^*(-\tau) \triangleq R_{XY}(\tau), \quad \tau = t_1 - t_2. \end{aligned}$$

Thus  $X(t)$  and  $Y(t)$  are jointly w.s.s. Further, the output autocorrelation simplifies to

$$\begin{aligned} R_{YY}(t_1, t_2) &= \int_{-\infty}^{+\infty} R_{XY}(t_1 - \beta - t_2) h(\beta) d\beta, \quad \tau = t_1 - t_2 \\ &= R_{XY}(\tau) * h(\tau) = R_{YY}(\tau). \end{aligned}$$

we obtain

$$R_{YY}(\tau) = R_{XX}(\tau) * h^*(-\tau) * h(\tau).$$

# Cross-Spectral Densities



the output process is also wide-sense stationary. This gives rise to the following representation

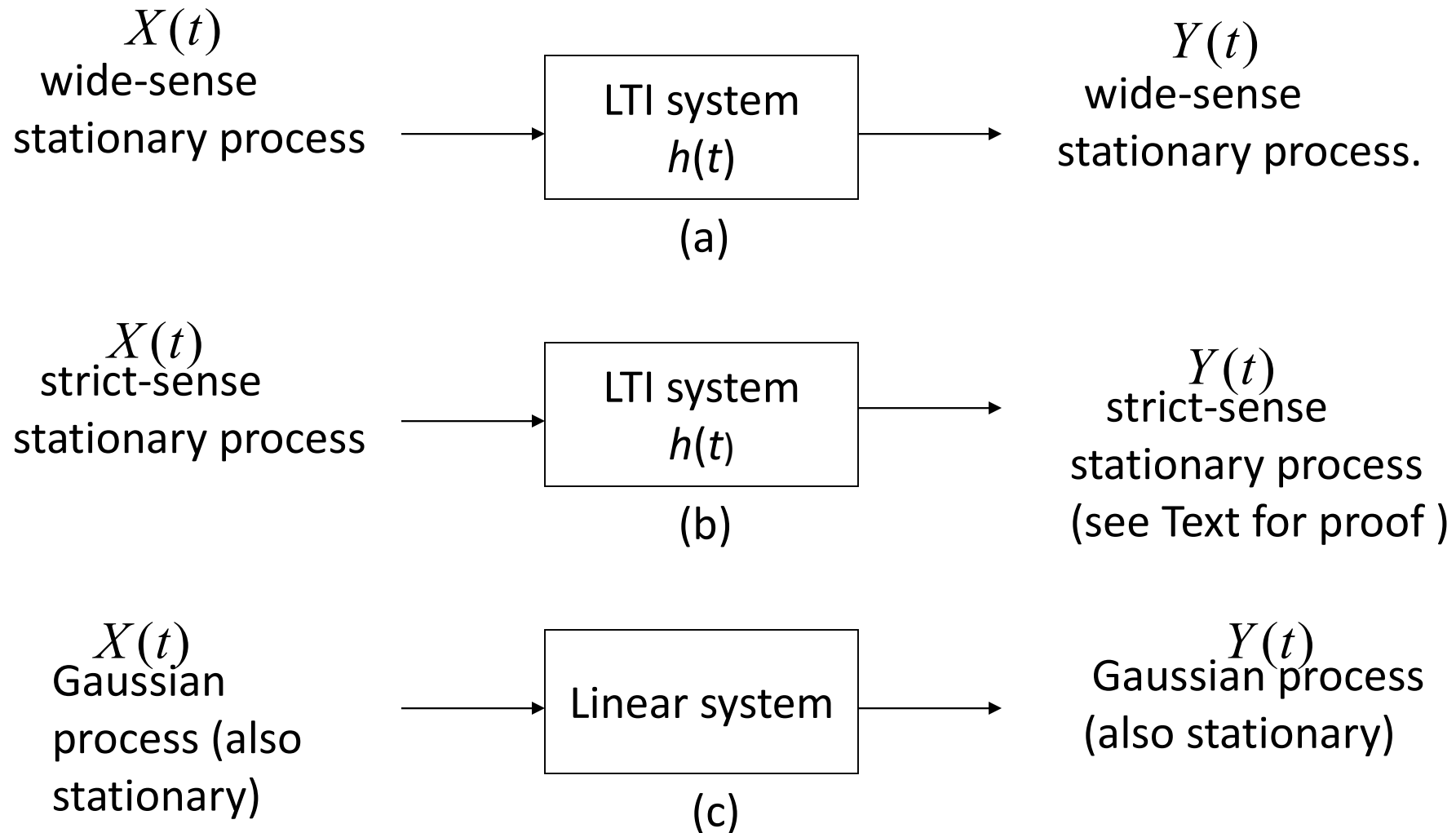

# White Noise Process



$W(t)$  is said to be a white noise process if

$$R_{ww}(t_1, t_2) = q(t_1)\delta(t_1 - t_2),$$

i.e.,  $E[W(t_1) W^*(t_2)] = 0$  unless  $t_1 = t_2$ .

$W(t)$  is said to be wide-sense stationary (w.s.s) white noise if  $E[W(t)] = \text{constant}$ , and

$$R_{ww}(t_1, t_2) = q\delta(t_1 - t_2) = q\delta(\tau).$$

If  $W(t)$  is also a Gaussian process (white Gaussian process), then all of its samples are independent random variables

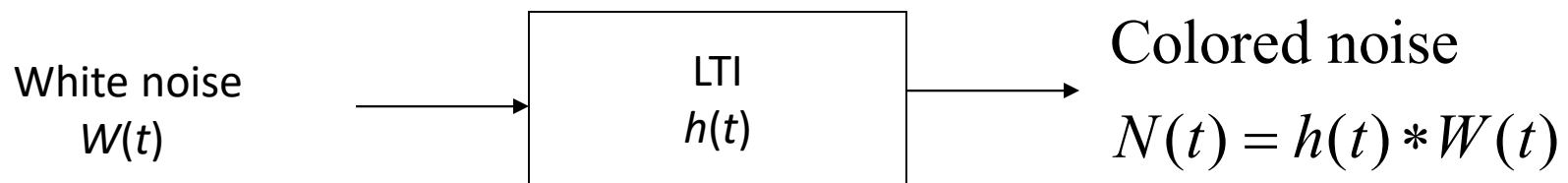

For w.s.s. white noise input  $W(t)$ , we have



# White Noise Process



$$E[N(t)] = \mu_w \int_{-\infty}^{+\infty} h(\tau) d\tau, \quad a \text{ constant}$$

and

$$\begin{aligned} R_m(\tau) &= q\delta(\tau) * h^*(-\tau) * h(\tau) \\ &= qh^*(-\tau) * h(\tau) = q\rho(\tau) \end{aligned}$$

where

$$\rho(\tau) = h(\tau) * h^*(-\tau) = \int_{-\infty}^{+\infty} h(\alpha) h^*(\alpha + \tau) d\alpha.$$

Thus the output of a white noise process through an LTI system represents a (colored) noise process.

Note: White noise need not be Gaussian.

“White” and “Gaussian” are two different concepts!

# Noise

Shot noise

Thermal noise

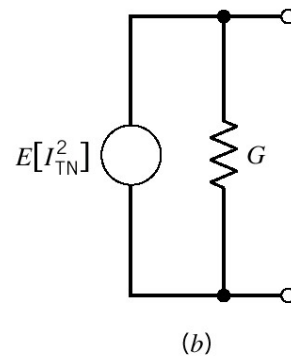
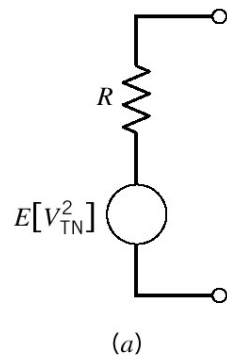

$$E[V_{TN}^2] = 4kTR\Delta f \quad \text{volts}^2$$

$$E[I_{TN}^2] = \frac{1}{R^2} E[V_{TN}^2] = 4kT \frac{1}{R} \Delta f = 4kTG\Delta f \quad \text{amps}^2$$

$k$ : Boltzmann's constant =  $1.38 \times 10^{-23}$  joules/K,  $T$  is the absolute temperature in degree Kelvin.

# White noise

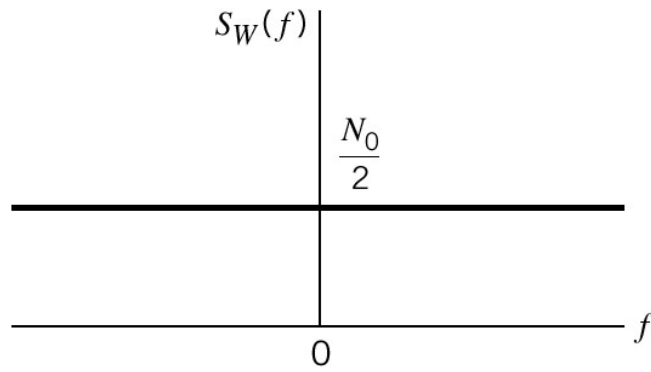

(a)

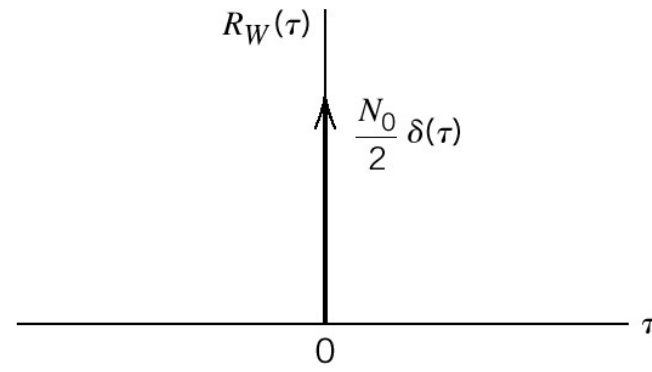

(b)

$$S_W(f) = \frac{N_0}{2}$$

$$N_0 = kT_e$$

$T_e$  : equivalent noise temperature of the receiver

$$R_W(\tau) = \frac{N_0}{2} \delta(\tau)$$

# Ideal Low-Pass Filtered White Noise

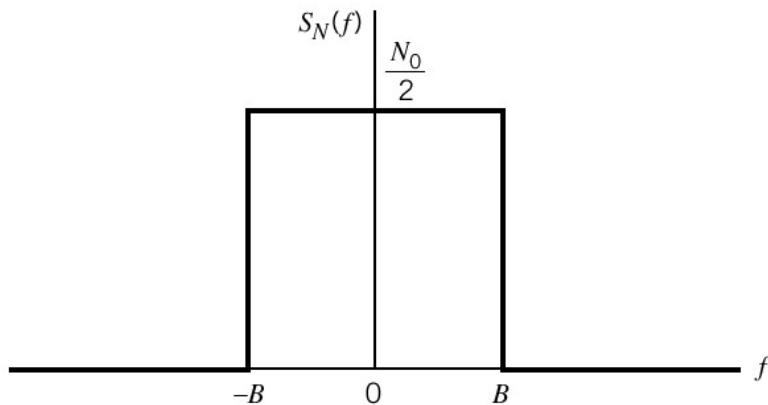

(a)

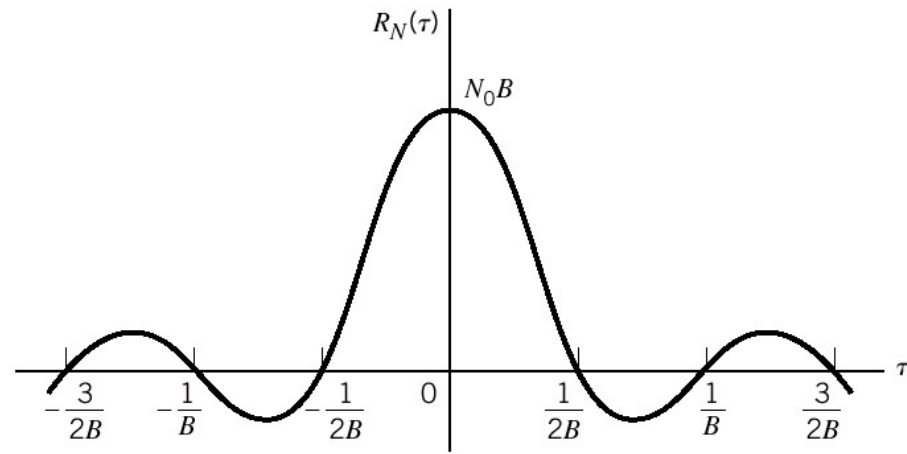

(b)

$$S_N(f) = \begin{cases} \frac{N_0}{2} & -B < f < B \\ 0 & |f| > B \end{cases}$$

$$\begin{aligned} R_N(\tau) &= \int_{-B}^B \frac{N_0}{2} \exp(j2\pi f\tau) df \\ &= N_0 B \operatorname{sinc}(2B\tau) \end{aligned}$$

# Correlation of White Noise with a Sinusoidal Wave

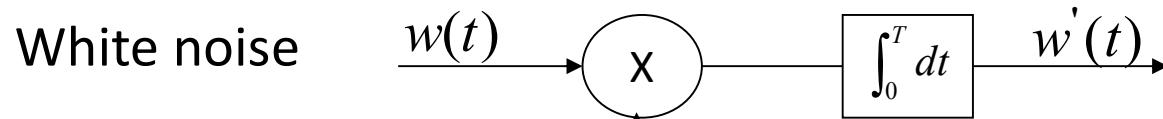

$$\sqrt{\frac{2}{T}} \cos(2\pi f_c t) \quad , \quad f_c = \frac{k}{T} \quad , \quad k \text{ is integer}$$

$$w'(t) = \sqrt{\frac{2}{T}} \int_0^T w(t) \cos(2\pi f_c t) dt$$

The variance of  $w'(t)$  is

$$\sigma^2 = E \left[ \frac{2}{T} \int_0^T \int_0^T w(t_1) \cos(2\pi f_c t_1) w(t_2) \cos(2\pi f_c t_2) dt_1 dt_2 \right]$$

$$= \frac{2}{T} \int_0^T \int_0^T E[w(t_1)w(t_2)] \cos(2\pi f_c t_1) \cos(2\pi f_c t_2) dt_1 dt_2$$

$$= \frac{2}{T} \int_0^T \int_0^T R_w(t_1, t_2) \cos(2\pi f_c t_1) \cos(2\pi f_c t_2) dt_1 dt_2$$

$$\sigma^2 = \frac{2}{T} \int_0^T \int_0^T \frac{N_0}{2} \delta(t_1 - t_2) \cos(2\pi f_c t_1) \cos(2\pi f_c t_2) dt_1 dt_2$$

$$= \frac{N_0}{T} \int_0^T \cos^2(2\pi f_c t) dt = \frac{N_0}{2}$$

# Narrowband Noise

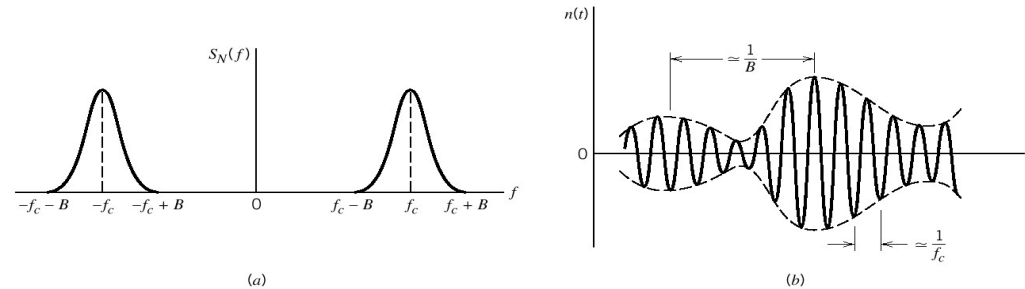

Two representations

a. in-phase and quadrature components ( $\cos(2\pi f_c t)$ ,  $\sin(2\pi f_c t)$ )

b. envelope and phase

## In-phase and quadrature representation

$$n(t) = n_I(t) \cos(2\pi f_c t) - n_Q(t) \sin(2\pi f_c t)$$

$n_I(t)$  and  $n_Q(t)$  are low - pass signals

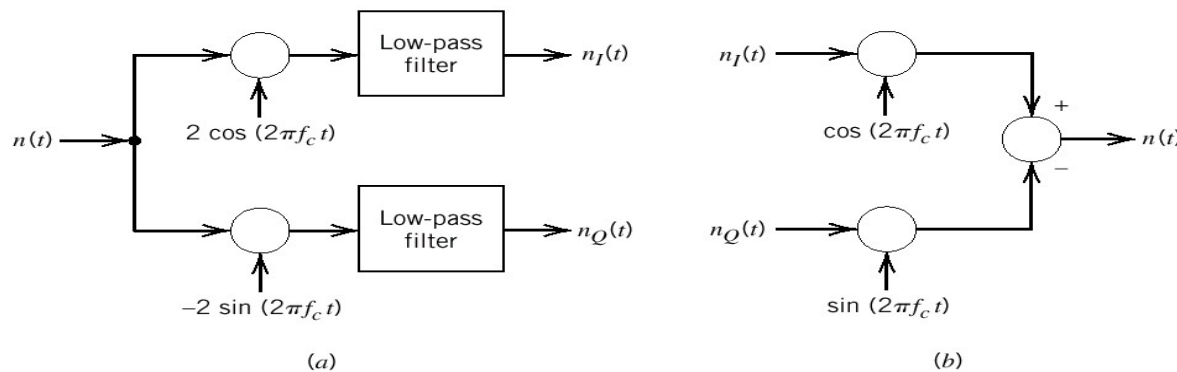

# Important Properties



1.  $n_I(t)$  and  $n_Q(t)$  have zero mean.

2. If  $n(t)$  is Gaussian then  $n_I(t)$  and  $n_Q(t)$  are jointly Gaussian.

3. If  $n(t)$  is stationary then  $n_I(t)$  and  $n_Q(t)$  are jointly stationary.

$$4. \quad S_{N_I}(f) = S_{N_Q}(f) = \begin{cases} S_N(f - f_c) + S_N(f + f_c), & -B \leq f \leq B \\ 0 & \text{otherwise} \end{cases}$$

5.  $n_I(t)$  and  $n_Q(t)$  have the same variance  $\frac{N_0}{2}$

6. Cross-spectral density is purely imaginary.

$$\begin{aligned} S_{N_I N_Q}(f) &= -S_{N_Q N_I}(f) \\ &= \begin{cases} j[S_N(f + f_c) - S_N(f - f_c)], & -B \leq f \leq B \\ 0 & \text{otherwise} \end{cases} \end{aligned}$$

7. If  $n(t)$  is Gaussian, its PSD is symmetric about  $f_c$ , then  $n_I(t)$  and  $n_Q(t)$  are statistically independent.

# Ideal Band-Pass Filtered White Noise

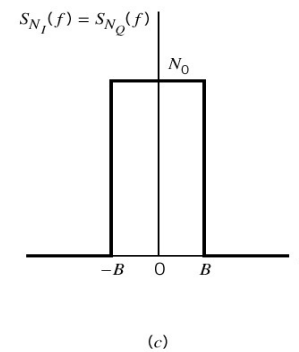
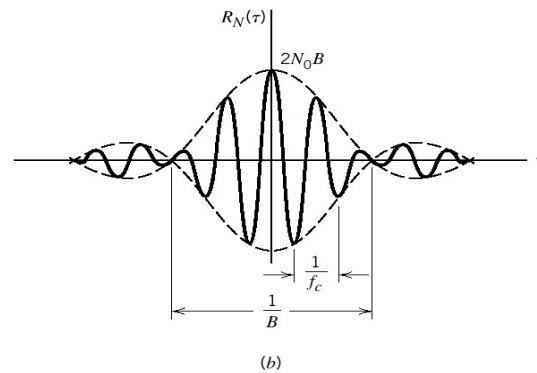
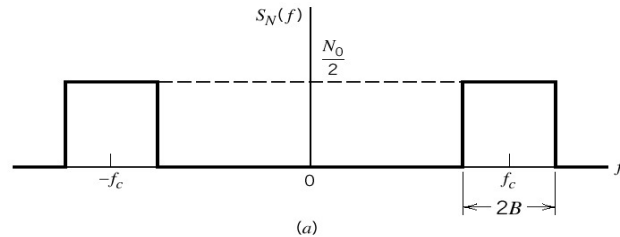

$$\begin{aligned}
 R_N(\tau) &= \int_{-f_c-B}^{-f_c+B} \frac{N_0}{2} \exp(j2\pi f\tau) df + \int_{f_c-B}^{f_c+B} \frac{N_0}{2} \exp(j2\pi f\tau) df \\
 &= N_0 B \operatorname{sinc}(2B\tau) [\exp(-j2\pi f_c\tau) \exp(j2\pi f_c\tau)] \\
 &= 2N_0 B \operatorname{sinc}(2B\tau) \cos(2\pi f_c\tau)
 \end{aligned}$$

Compare (a factor of  $\tau$ ),

$$R_{N_I}(\tau) = R_{N_Q}(\tau) = 2N_0 B \operatorname{sinc}(2B\tau).$$