

**LECTURE NOTES**  
**ON**  
**DYNAMICS OF MACHINERY**  
**(AME011)**

**B.Tech V Semester**

Prepared by

Dr. K.Viswanath Allamraju



**MECHANICAL ENGINEERING**

**Institute of Aeronautical Engineering**

(Autonomous)  
Dundigal, Hyderabad

## UNIT – I

### PRECISIONAL MOTION AND FORCE ANALYSIS

#### Introduction

Whilst Gyroscopes are used extensively in aircraft instrumentation and have been utilised in monorail trains, the everyday impact of gyroscopic forces on our lives is unappreciated and significant. The simple example is a child's top which would not work but for the gyroscopic couple which keeps it upright. On a slightly different level, the gyroscopic couple helps us to keep a bicycle upright. It is interesting and instructive to remove a bicycle wheel from its frame, hold it by the axle, spin the wheel and then try to change the orientation of the axle. The force required to do so is considerable! However these gyroscopic forces are not always beneficial and it will be shown that the effect on the wheels of a car rounding a corner is to increase the tendency for the vehicle to turn over.

#### Gyroscopic Couple

Without an understanding of Angular movement it is difficult to understand Gyroscopic Couples. For this reason the Paragraph on Angular Displacement; Velocity and Acceleration shown in The Theory of Machines - Mechanisms, has been reproduced here.

If a uniform disc of polar moment of inertia  $I$  is rotated about its axis with an angular velocity  $\omega$ , its **Angular Momentum**  $I\omega$  is a vector and can be represented in diagram (c), by the line  $op$  which is drawn in the direction of the axis of rotation. The sense of the rotation is clockwise when looking in the direction of the arrow.

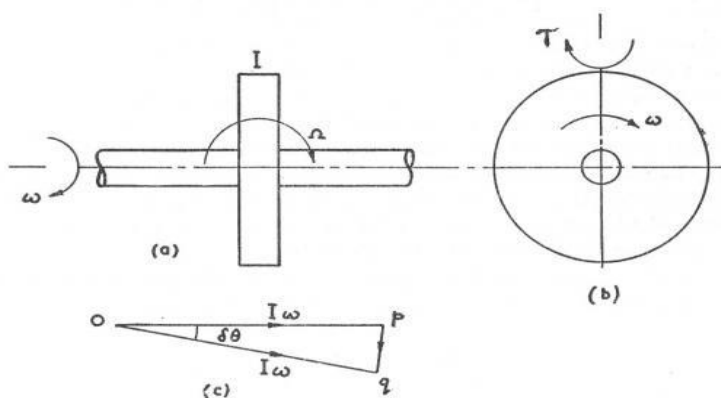

If now the axis of rotation is **precessing** with a uniform angular velocity  $\Omega$  about an axis perpendicular to that of  $\omega$ , then after a time  $\delta t$ , the axis of rotation will have turned through an angle  $\delta\theta = \Omega t$  and the momentum vector will be  $oq$ . The **Gyroscopic Couple**  $\tau$  is given by:-

$$\tau = \text{The rate of change of angular momentum} = \frac{pq}{\delta t}$$

$$= \frac{I\omega \delta\theta}{\delta t} = I\omega\Omega \quad \text{In the limit}$$

- The direction of the couple acting on the gyroscope is that of a clockwise rotation when looking in the direction pq.
- In the limit the direction of the couple is perpendicular to the axe of both  $\omega$  and  $\Omega$
- The reaction couple exerted by the gyroscope on its frame is in the **reverse sense**( It is advisable to draw the vector triangle opq in each case.

### Angular Displacement, Velocity And Acceleration

Let:- The line OP in the diagram rotates around O

- Its inclination relative to OX be  $\phi$  radians.

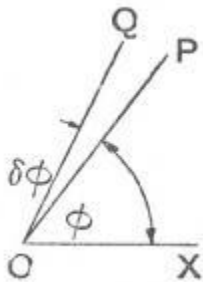

Then if after a short period of time the line has moved to lie along OQ, then the angle  $\delta\theta$  is **The Angular Displacement** of the line.

- **Angular Displacement** is a vector quantity since it has both magnitude and direction.

Angular Displacement:

In order to completely specify and angular displacement by a vector, the vector must fix:-

- The direction of the axis of rotation in space.
- The sense of the angular displacement. i.e. whether clockwise or anti-clockwise.
- The magnitude of the angular displacement.

In order to fix the vector can be drawn at right angles to the plane in which the angular displacement

takes place, say along the axis of rotation and its length will be , to a convenient scale, the magnitude of the displacement.

The conventional way of representing the sense of the vector , is to use the right-hand screw rule. i.e.,

- The arrow head points along the vector in the same direction as a right handed screw would move, relative to a fixed nut.
- Using the above convention, the angular displacement  $\delta\theta$  shown in the diagram would be represented by a vector perpendicular to the plane of the screen and the arrow head would point away from the screen.

Angular Velocity:

- This is defined as the rate of change of angular displacement with respect to time.
- As angular velocity has both magnitude and direction it is a **vector quantity** and may be represented in the same way as angular displacement.
- If the direction of the angular displacement vector is constant. i.e. The plane of the angular displacement does not change its direction,. Then the angular velocity is merely the change in magnitude of the angular displacement with respect to time.

Angular Acceleration:

- Defined as the rate of change of angular velocity with respect to time.
- A Vector quantity.
- The direction of the acceleration vector is not necessarily the same as the displacement and velocity vectors.

Assume that a given instant a disc is spinning with an angular velocity of  $\omega$  in a plane at right angles to the screen and that after a short interval of  $\delta t$  its speed has increased to  $\omega + \delta\omega$ .

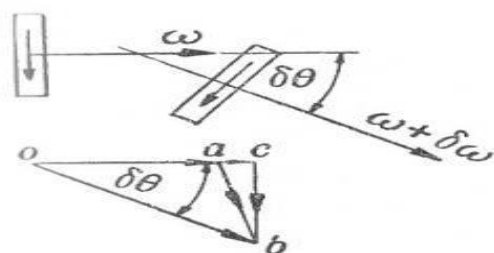



Then applying the right-hand rule:-

- The angular velocities at the two instants are represented by the vectors **oa** and **ob**
- The change of angular velocity in a time of  $\delta t$  is represented by the vector **ab**. This can be resolved into two components **ac** and **cb** which are respectively parallel and perpendicular to **oa**

- The component parallel to oa is given by:-  $\alpha_T = \frac{d\omega}{dt}$

- The component perpendicular to oa is given by  $\alpha_C = \omega \frac{d\theta}{dt} = \omega \times \omega_P$

The subject Dynamics of Machines may be defined as that branch of Engineering-science, which deals with the study of relative motion between the various parts of a machine, and forces which act on them. The knowledge of this subject is very essential for an engineer in designing the various parts of a machine. A machine is a device which receives energy in some available form and utilises it to do some particular type of work. If the acceleration of moving links in a mechanism is running with considerable amount of linear and/or angular accelerations, inertia forces are generated and these inertia forces also must be overcome by the driving motor as an addition to the forces exerted by the external load or work the mechanism does.

## **NEWTON'S LAW :**

### **First Law:**

Everybody will persist in its state of rest or of uniform motion (constant velocity) in a straight line unless it is compelled to change that state by forces impressed on it. This means that in the absence of a non-zero net force, the center of mass of a body either is at rest or moves at a constant velocity.

### **Second Law**

A body of mass  $m$  subject to a force **F** undergoes an acceleration **a** that has the same direction as the force and a magnitude that is directly proportional to the force and inversely proportional to the mass, i.e.,  $\mathbf{F} = m\mathbf{a}$ . Alternatively, the total force applied on a body is equal to the time derivative of linear momentum of the body.

### **Third Law**

The mutual forces of action and reaction between two bodies are equal, opposite and collinear. This means that whenever a first body exerts a force  $\mathbf{F}$  on a second body, the second body exerts a force  $-\mathbf{F}$  on the first body.  $\mathbf{F}$  and  $-\mathbf{F}$  are equal in magnitude and opposite in direction. This law is sometimes referred to as the *action-reaction law*, with  $\mathbf{F}$  called the "action" and  $-\mathbf{F}$  the "reaction".

### **Principle of Super Position:**

Sometimes the number of external forces and inertial forces acting on a mechanism are too much for graphical solution. In this case we apply the method of superposition. Using superposition the entire system is broken up into (n) problems, where n is the number of forces, by considering the external and inertial forces of each link individually. Response of a linear system to several forces acting simultaneously is equal to the sum of responses of the system to the forces individually. This approach is useful because it can be performed by graphically.

### **Free Body Diagram:**

A free body diagram is a pictorial representation often used by physicists and engineers to analyze the forces acting on a body of interest. A free body diagram shows all forces of all types acting on this body. Drawing such a diagram can aid in solving for the unknown forces or the equations of motion of the body. Creating a free body diagram can make it easier to understand the forces, and torques or moments, in relation to one another and suggest the proper concepts to apply in order to find the solution to a problem. The diagrams are also used as a conceptual device to help identify the internal forces—for example, shear forces and bending moments in beams—which are developed within structures.

### **DYNAMIC ANALYSIS OF FOUR BAR MECHANISM:**

A **four-bar linkage** or simply a **4-bar** is the simplest movable linkage. It consists of four rigid bodies (called bars or links), each attached to two others by single joints or pivots to form closed loop. Four- bars are simple mechanisms common in mechanical engineering machine design and fall under the study of kinematics.

### **D'Alembert's Principle**

Consider a rigid body acted upon by a system of forces. The system may be reduced to a single resultant force acting on the body whose magnitude is given by the product of the mass of the body

and the linear acceleration of the centre of mass of the body. According to Newton's second law of motion,

$$F = m.a$$

$F$  = Resultant force acting on the body,

$m$  = Mass of the body, and

$a$  = Linear acceleration of the centre of mass of the  $a$  body.

The equation (i) may also be written as:  $F - m.a = 0$

A little consideration will show, that if the quantity  $-m.a$  be treated as a force, equal, opposite and with the same line of action as the resultant force  $F$ , and include this force with the system of forces of which  $F$  is the resultant, then the complete system of forces will be in equilibrium. This principle is known as D- Alembert's principle. The equal and opposite force  $-m.a$  is known as reversed effective force or the inertia force (briefly written as  $F_I$ ). The equation (ii) may be written as  $F + F_I = 0$ ...(iii)

Thus, D-Alembert's principle states that the resultant force acting on a body together with the reversed effective force (or inertia force), are in equilibrium. This principle is used to reduce a dynamic problem into an equivalent static problem.

### **Velocity and Acceleration of the Reciprocating Parts in Engines**

The velocity and acceleration of the reciprocating parts of the steam engine or internal combustion engine (briefly called as I.C. engine) may be determined by graphical method or analytical method. The velocity and acceleration, by graphical method, may be determined by one of the following constructions: **1.** Klien's construction, **2.** Ritterhaus's construction, and **3.** Bennett's construction.

### **SOLVED PROBLEMS**

The crank and connecting rod of a reciprocating engine are 200 mm and 700 mm respectively. The crank is rotating in clockwise direction at 120 rad/s. Find with the help of Klein's construction: **1.** Velocity and acceleration of the piston, **2.** Velocity and acceleration of the mid point of the connecting rod, and **3.** Angular velocity and angular acceleration of the connecting rod, at the instant when the crank is at  $30^\circ$  to I.D.C. (inner dead centre).

**Solution.** Given:  $OC = 200 \text{ mm} = 0.2 \text{ m}$  ;  $PC = 700 \text{ mm} = 0.7 \text{ m}$  ;  $\omega = 120 \text{ rad/s}$

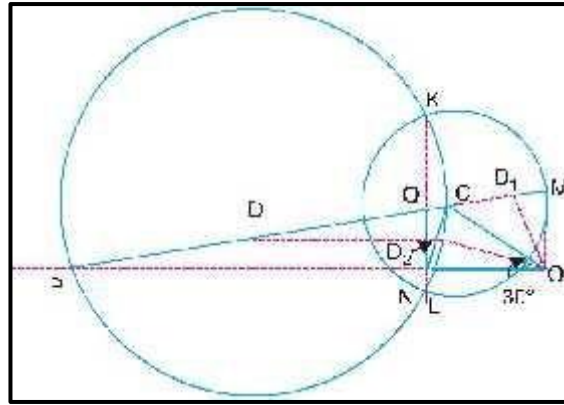

**Fig. 1**

The Klein's velocity diagram  $OCM$  and Klein's acceleration diagram  $CQNO$  as shown in Fig. 1 is drawn to some suitable scale, in the similar way as discussed in Art. 15.5. By measurement, we find that  $OM = 127 \text{ mm} = 0.127 \text{ m}$  ;  $CM = 173 \text{ mm} = 0.173 \text{ m}$  ;  $QN = 93 \text{ mm} = 0.093 \text{ m}$  ;  $NO = 200 \text{ mm}$

***Velocity and acceleration of the piston***

We know that the velocity of the piston  $P$ ,  $v_p = \omega \times OM = 120 \times 0.127 = 15.24 \text{ m/s}$  **Ans.**

Acceleration of the piston  $P$ ,  $a_p = \omega^2 \times NO = (120)^2 \times 0.2 = 2880 \text{ m/s}^2$  **Ans.**

***Velocity and acceleration of the mid-point of the connecting rod***

In order to find the velocity of the mid-point  $D$  of the connecting rod, divide  $CM$  at  $D_1$  in the same ratio as  $D$  divides  $CP$ . Since  $D$  is the mid-point of  $CP$ , therefore  $D_1$  is the mid-point of  $CM$ , i.e.  $CD_1 = D_1M$ . Join  $OD_1$ . By measurement,  $OD_1 = 140 \text{ mm} = 0.14 \text{ m}$

Velocity of  $D$ ,  $v_D = \omega \times OD_1 = 120 \times 0.14 = 16.8 \text{ m/s}$  **Ans.**

In order to find the acceleration of the mid-point of the connecting rod, draw a line  $DD_2$  parallel to the line of stroke  $PO$  which intersects  $CN$  at  $D_2$ . By measurement,

$OD_2 = 193 \text{ mm} = 0.193 \text{ m}$

$\therefore$  Acceleration of  $D$ ,

$a_D = \omega^2 \times OD_2 = (120)^2 \times 0.193 = 2779.2 \text{ m/s}^2$  **Ans.**

***1. Angular velocity and angular acceleration of the connecting rod***

We know that the velocity of the connecting rod  $PC$  (i.e. velocity of  $P$  with respect to

$$C), v_{PC} = \omega \times CM = 120 \times 0.173 = 20.76 \text{ m/s}$$



## EQUIVALENT DYNAMICAL SYSTEM

In order to determine the motion of a rigid body, under the action of external forces, it is usually convenient to replace the rigid body by two masses placed at a fixed distance apart, in such a way that,

1. the sum of their masses is equal to the total mass of the body ;
2. the centre of gravity of the two masses coincides with that of the body ; and
3. the sum of mass moment of inertia of the masses about their centre of gravity is equal to the mass moment of inertia of the body.

When these three conditions are satisfied, then it is said to be an *equivalent dynamical system*.

Consider a rigid body, having its centre of gravity at  $G$ ,

Let  $m$  = Mass of the body,  $k_G$  = Radius of gyration about its centre of gravity  $G$ ,

$m_1$  and  $m_2$  = Two masses which form a dynamical equivalent system,

## CORRECTION COUPLE TO BE APPLIED TO MAKE TWO MASS SYSTEM

### DYNAMICALLY EQUIVALENT

In Art.2 , we have discussed the conditions for equivalent dynamical system of two bodies. A little consideration will show that when two masses are placed arbitrarily\*, then the conditions (i) and (ii) as given in Art. 2 will only be satisfied. But the condition (iii) is not possible to satisfy. This means that the mass moment of inertia of these two masses placed arbitrarily, will differ than that of mass moment of inertia of the rigid body.

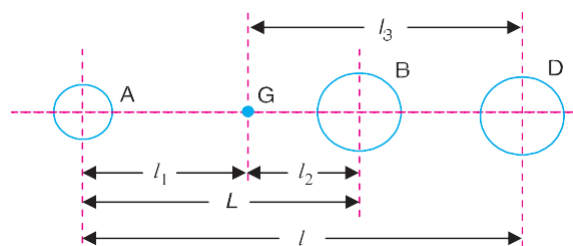

**Fig. 2.** Correction couple to be applied to make the two-mass system dynamically equivalent.

## INERTIA FORCES IN A RECIPROCATING ENGINE, CONSIDERING THE WEIGHT OFCONNECTING ROD

In a reciprocating engine, let  $OC$  be the crank and  $PC$ , the connecting rod whose centre of gravity lies at  $G$ . The inertia forces in a reciprocating engine may be obtained graphically as discussed



between the crosshead and the guide bars ( $F_N$ ) acting at  $P$  and right angles to line of stroke  $PO$ ,

The weight of the connecting rod ( $W_C = m_C \cdot g$ ),

Inertia force of the connecting rod ( $F_C$ ),

(a) The radial force ( $F_R$ ) acting through  $O$  and parallel to the crank  $OC$ ,

(b) The force ( $F_T$ ) acting perpendicular to the crank  $OC$ .

Now, produce the lines of action of  $F_R$  and  $F_N$  to intersect at a point  $I$ , known as instantaneous centre. From  $I$  draw  $IX$  and  $IY$ , perpendicular to the lines of action of  $F_C$  and  $W_C$ . Taking moments about  $I$ ,

$$F_T \times IC = F_I \times IP + F_C \times IX + W_C \times IY \quad \dots(ii)$$

The value of  $F_T$  may be obtained from this equation and from the force polygon as shown in Fig. 15.22, the forces  $F_N$  and  $F_R$  may be calculated. We know that, torque exerted on the crankshaft to overcome the inertia of the moving parts =  $F_T \times OC$

## UNIT-II

### CLUTCH, BRAKE & DYNAMOMETER

#### CLUTCH:

It is the device used in the transmission system of the vehicle to engage and disengage the engine to the transmission, thus the clutch is located between the engine and gearbox. When the clutch is engaged the power flows from the engine to the gearbox.

Types of clutches

1. Single plate clutch
2. Cone clutch

#### SINGLE PLATE CLUTCH:

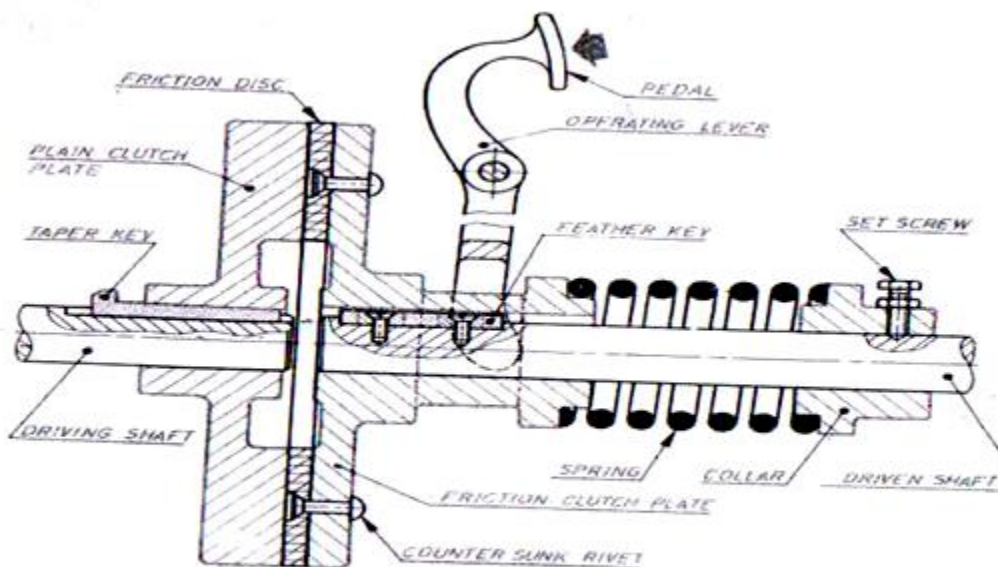

**Single Plate Clutch**

It is the most common type of clutch used in the motor vehicles. The driving shaft is connected to the clutch plate by means of taper key and the driven shaft is connected to the clutch plate by means of feather key. The friction disc is secured between 2 clutch plates and fastened by the rivet. The clutch plate is still extended to accommodate the operating lever. The spring is held by a collar by means of external source the collar slides in the shaft which applies the pressure to the clutch plate through the spring. As the pressure is applied the friction disc and the clutch plate comes more closer there by it starts rotating by means of a shaft. However when it is desired to disengage, the lever is pushed which moves the clutch plate by compressing the spring over the driven shaft to disengage the driving and driven shaft.

## CONE FRICTION CLUTCH:

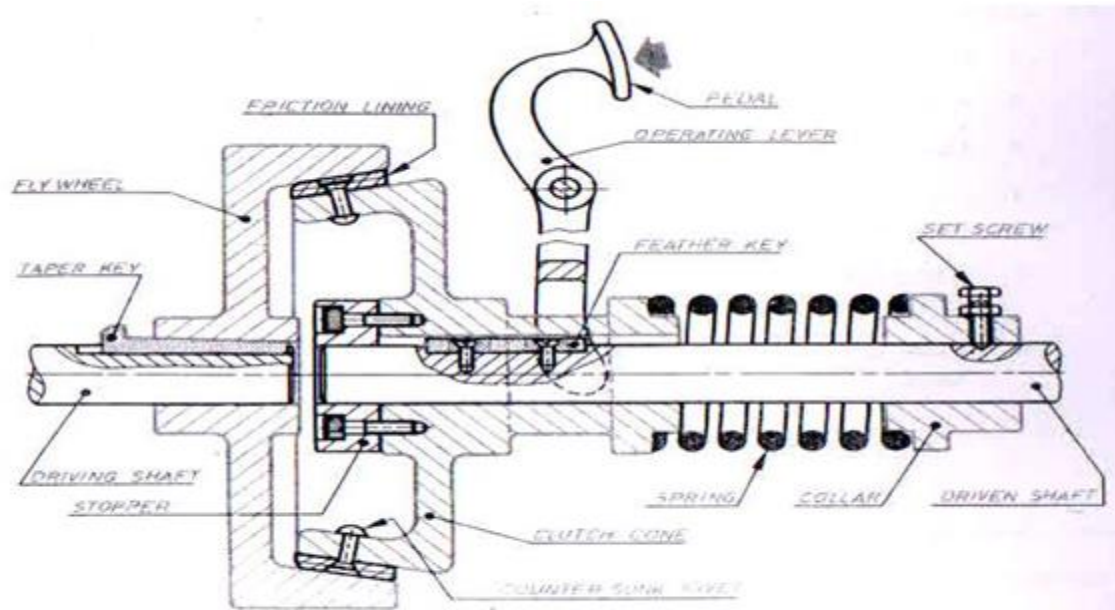

Cone Friction Clutch

The driving shaft is connected to the flywheel by means of taper key and driven shaft is connected to the cone clutch by means of feather key. The cone clutch comes in contact with the flywheel by means of friction lining. The cone clutch is extended to accommodate the operating lever. The spring is held by a collar. When the clutch is engaged the collar is pushed the cone clutch and applies the pressure through the spring. When the clutch has to be disengaged, the operating lever is pressed which prevents the contact from the clutch plate to the flywheel there by disengaging the driving and driven shafts.

## FUNCTIONS OF CLUTCH

The clutch is located between the engine and the gearbox

1. When the clutch is engaged the power flows from the engine to the wheels through the gear box and vehicle moves.
2. When the clutch is disengaged the power is not flown to the wheels from the engine through the gear box.
3. The clutch will be disengaged when starting the engine, stopping the engine.
4. The clutch permits the vehicle to take up the gradual load.
5. When properly operated, it prevents the jerky motion of the vehicle thus preventing the strain applied to the transmission system.

## DYNAMOMETER

It is the device used to measure the frictional forces in the steam engines, IC engines, steam turbines etc.

### CLASSIFICATION

1. Absorption dynamometer
2. Transmission dynamometer

### ABSORPTION DYNAMOMETER:

It absorbs the available power while working against the friction. It is of 2 types. They are:

- a. Mechanical friction dynamometer
- b. Hydraulic dynamometer
- c. Electrical friction dynamometer

Mechanical friction dynamometer is again classified as

- a. Prony brake dynamometer
- b. Rope brake dynamometer

### TRANSMISSION DYNAMOMETER:

It transmits the power at the mechanical joints of the parts of the dynamometer. It is of 2 types:

Belt transmission dynamometer

Epicyclic transmission dynamometer

Torsion transmission dynamometer

### PRONY DYNAMOMETER:

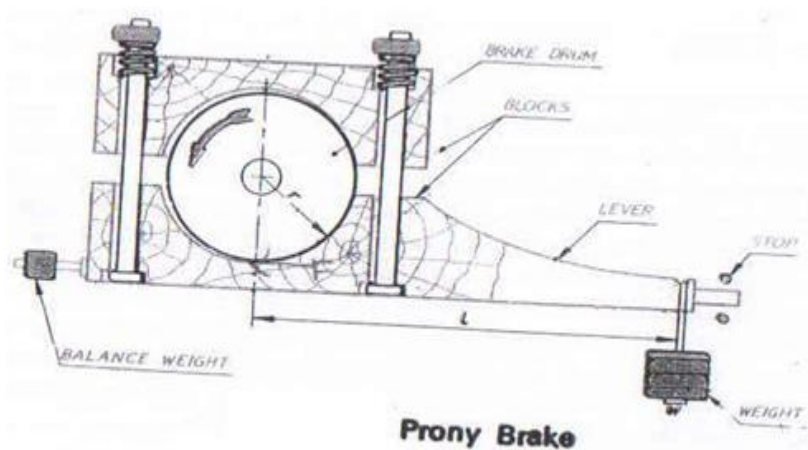

It is the simplest type of the absorption dynamometer. It consists of 2 blocks of wood which are

clamped by means of a bolt. The upper block is bolted with the help of a spring so as to increase the pressure on a revolving brake drum. The lower block is connected to the lever carrying the dead weight. However the balance weight balances the brake when unloaded. During the rotation of the brake drum, the block starts vibrating which is controlled by means of a dead weight. The friction pressure on the brake drum is adjusted by means of the bolts until the brake drum runs at the required speed. The power transmitted is calculated using the formula

$$HP = \frac{2 \pi NT}{60 \times 1000} W$$

N= RPM, T= torque applied on the net load on the brake drum, kNm

$$T = W \cdot R \quad W = \text{net load acting on the brake drum, kg}$$

$$R = \text{radius of the brake drum, m}$$

### ROPE BRAKE DYNAMOMETER:

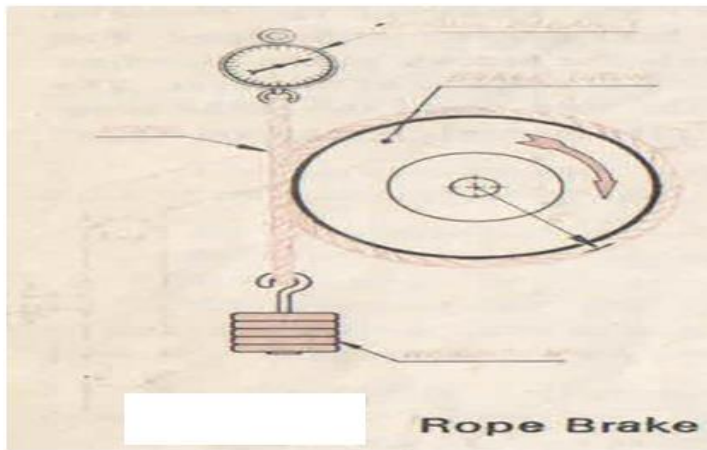

This brake consists of a brake drum over which the rope is being attached and wound. The upper ends being connected together and attached to the spring balance which is hung from a support and the lower ends are connected to the external weight W. the external weight W is adjusted until the brake drum rotates at the desired speed. The power transmitted is calculated using the formula

$$HP = \frac{2 \pi NT}{60 \times 1000} W$$

$$= \frac{2 \pi N(W-S)r}{60 \times 1000} W$$

W= external weight, N      S= spring balance reading, N      r=radius of a brake drum, m      N= RPM

## BELT TRANSMISSION DYNAMOMETER:

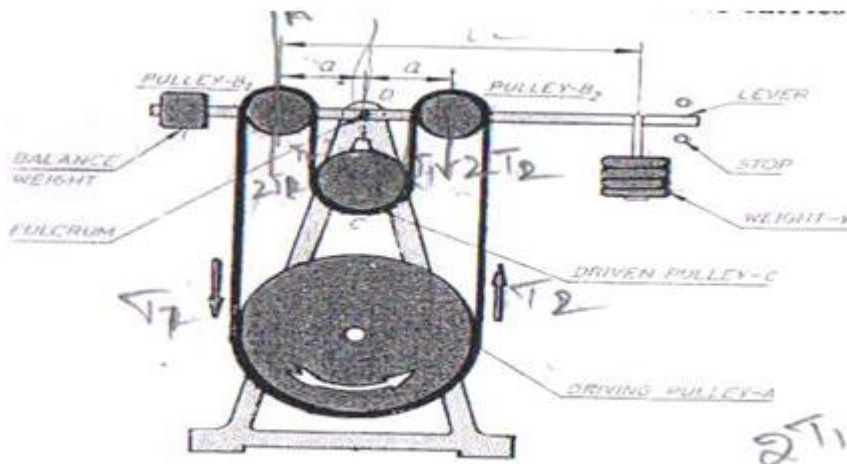

**Belt Transmission Dynamometer**

It consists of a frame mounted with a driving pulley A and driven pulley C. A lever pivoted at the junction D carries the balance weight at one end and the external weight W at the other end. The lever carries 2 intermediate pulleys B1 and B2. an endless belt passes from the driving pulley A, over the intermediate pulleys B1 and B2 to the driven pulley C. if the driven pulley revolves in the anticlockwise direction, the tight and the slack sides of the belt are shown. The power transmitted is calculated using the formula

$$HP = \frac{2\pi NT}{60 \times 1000} W$$

N= RPM, T= torque applied on the net load on the brake drum, kNm

## BRAKES

It is the device used to bring the rotating body to the rest.

### CLASSIFICATION:

- a. Block brake
- b. Band brakes
- c. Block and band brake
- d. External and internal expanding shoe brake



**BLOCK BRAKE:** used in railway carriages, road rollers etc

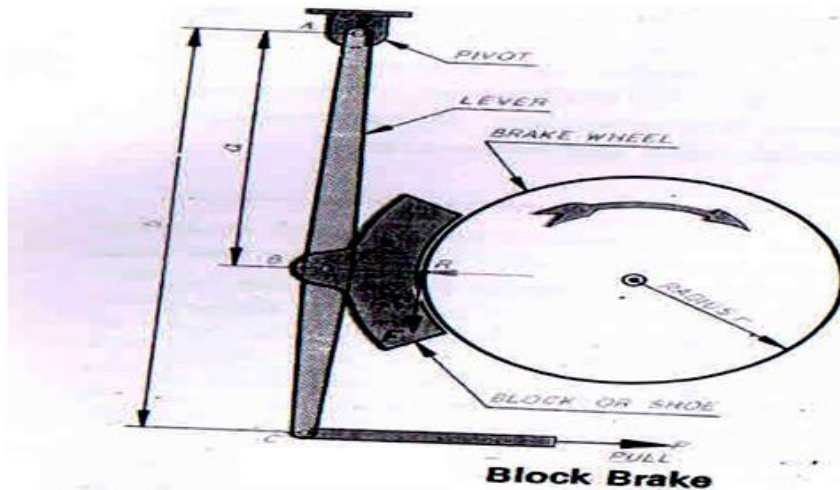

The block brake consists of a lever pivoted at A, connected at B to a block which may be held pressed against the rim of a rotating wheel by applying a pull at the other end C of a lever. When the brake is applied by applying a pull P, the friction between the block and the rim of the wheel causes the tangential force F to act on the rim against its motion.

Work done against friction = friction force \* S

$$= ((\mu P b) a) * S$$

$\mu$  = coefficient of friction, P = external pull, S = linear distance travelled, Tangential force  $F = \mu R$ .

**BAND BRAKE:** The band is tightened round the drum and the friction between the band and the drum provides the tangential braking torque. The two types of brakes are...

1. Simple band brake
2. Differential band brake

**SIMPLE BAND BRAKE:**

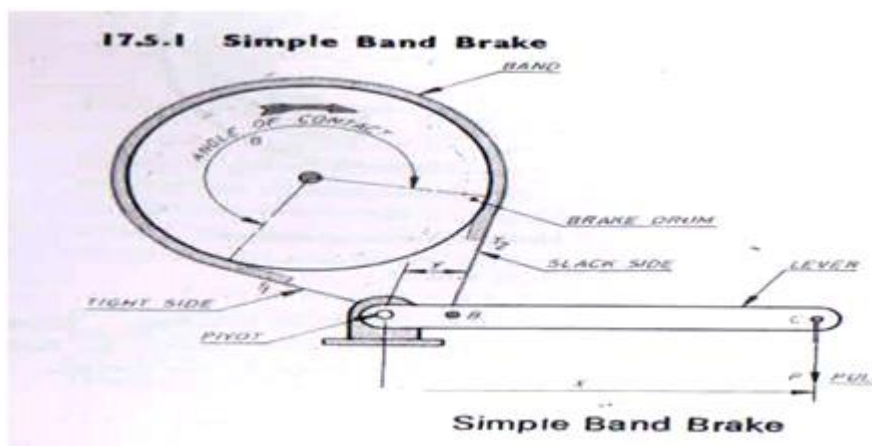

One end of band is connected to the pivot end of the lever and the other end is connected to intermediate point of the lever. The pull P applied at the end of the lever as shown, produces tensions

$T_1$  and  $T_2$  in the band and these cause a frictional force between the band and the drum.  $T_1$ = tension in the tight side of the band,  $T_2$ = tension in the slack side of the band,  $\Theta$ = angle of contact in radians,  $\mu$ = coefficient of friction. The braking force  $P = (T_2y)/x$

**DIFFERENTIAL BAND BRAKE:**

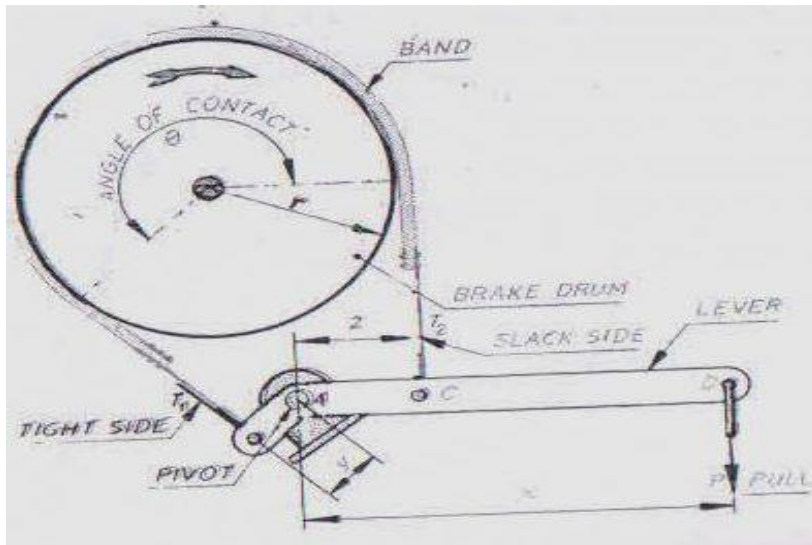

One end of the band is connected to the end of the short bent lever. The other end is connected to the pin on a point on the long lever. Applying the pull  $P$  at the end of the lever as shown  $T_1$  and  $T_2$  are produced in the band and these cause the frictional force between the band and the drum.

**BAND AND BLOCK BRAKE:**

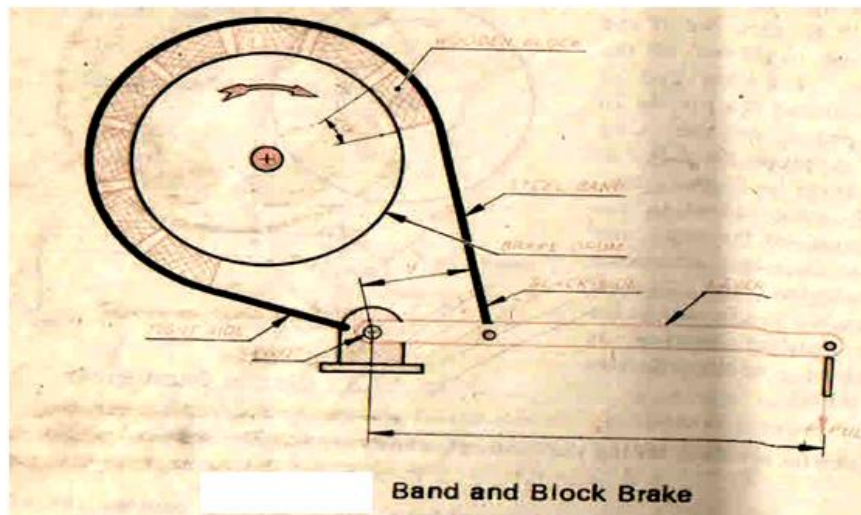

This is the modification of band brake. It consists of number of wooden blocks fixed to a steel band. Both the band and block are the part of the wheel.

## INTERNAL EXPANDING SHOE BRAKE:

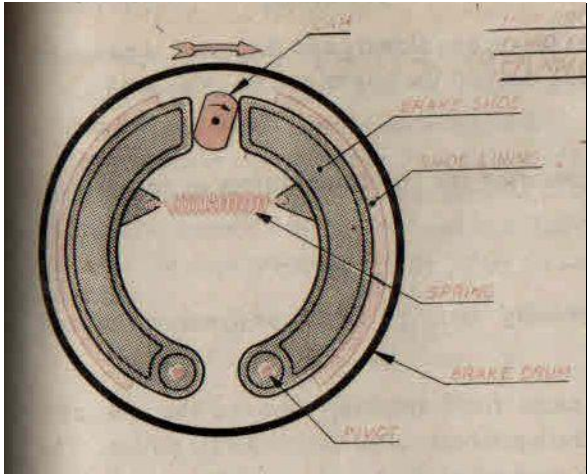

In mechanically operated brakes, as soon as the brake pedal is depressed, the cam rotates partly which thrusts the shoes against the inner flanges of the drum to stop it from rotating. When the brake pedal is released the cam rotates back and the 2 shoes are drawn back by the spring. In hydraulically operated brakes, as soon as the brake pedal is depressed, a piston in the master cylinder moves which increases the pressure of the fluid, the fluid is then passed to the wheel cylinder. The pressure of the fluid in the wheel cylinder forces the 2 pistons in the wheel cylinder apart against the tension of the spring which connects the 2 shoes. As a result the shoes thrust against the brake drum so as to stop it from rotating. When the brake pedal is released the pressure in the master cylinder reduces which in turn reduces the pressure in wheel cylinder and the 2 shoes are drawn back by the spring.

## UNIT-III

### TURNING MOMENT DIAGRAM, GOVERNORS

The turning moment diagram (also known as *crank-effort diagram*) is the graphical representation of the turning moment or crank-effort for various positions of the crank. It is plotted on cartesian co-ordinates, in which the turning moment is taken as the ordinate and crank angle as abscissa

#### Turning Moment Diagram for a Single Cylinder Double Acting Steam Engine

A turning moment diagram for a single cylinder double acting steam engine is shown in Fig. The vertical ordinate represents the turning moment and the horizontal ordinate represents the crank angle.

$$T = F_p \times r \left( \sin \theta + \frac{\sin 2\theta}{2\sqrt{n^2 - \sin^2 \theta}} \right)$$

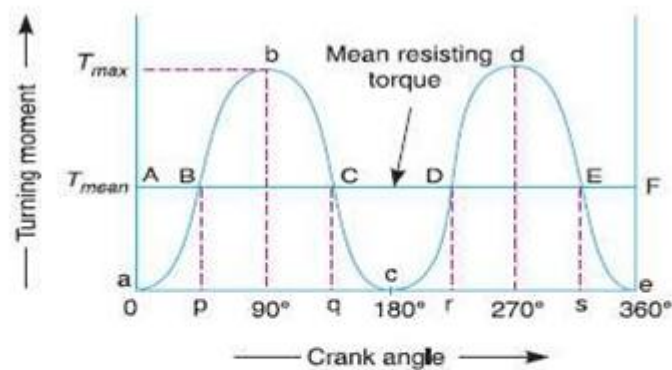

**Fig.** Turning moment diagram for a single cylinder, double acting steam engine.

where

$F_p$  = Piston effort,

$r$  = Radius of crank,

$n$  = Ratio of the connecting rod length and radius of crank, and

$\theta$  = Angle turned by the crank from inner dead centre.

From the above expression, we see that the turning moment ( $T$ ) is zero, when the crank angle ( $\theta$ ) is zero. It is maximum when the crank angle is  $90^\circ$  and it is again zero when crank angle is  $180^\circ$ . This is shown by the curve  $abc$  in Fig. 16.1 and it represents the turning moment diagram for outstroke. The curve  $cde$  is the turning moment diagram for instroke and is somewhat similar to the curve  $abc$ . Since the work done is the product of the turning moment and the angle turned, therefore the area of the turning moment diagram represents the work done per revolution. In actual practice, the engine is assumed to work against the mean resisting torque, as shown by a horizontal line  $AF$ . The height of the ordinate  $a$  represents the mean height of the turning moment diagram. Since it is assumed that the work done by the turning moment per revolution is equal to the work done against the mean

resisting torque, therefore the area of the rectangle  $aAFe$  is proportional to the work done against the mean resisting torque.

### Turning Moment Diagram for 4s IC Engine

A turning moment diagram for a four stroke cycle internal combustion engine is shown in Fig.2. We know that in a four stroke cycle internal combustion engine, there is one working stroke after the crank has turned through two revolutions, *i.e.*  $720^\circ$  (or  $4\pi$  radians).

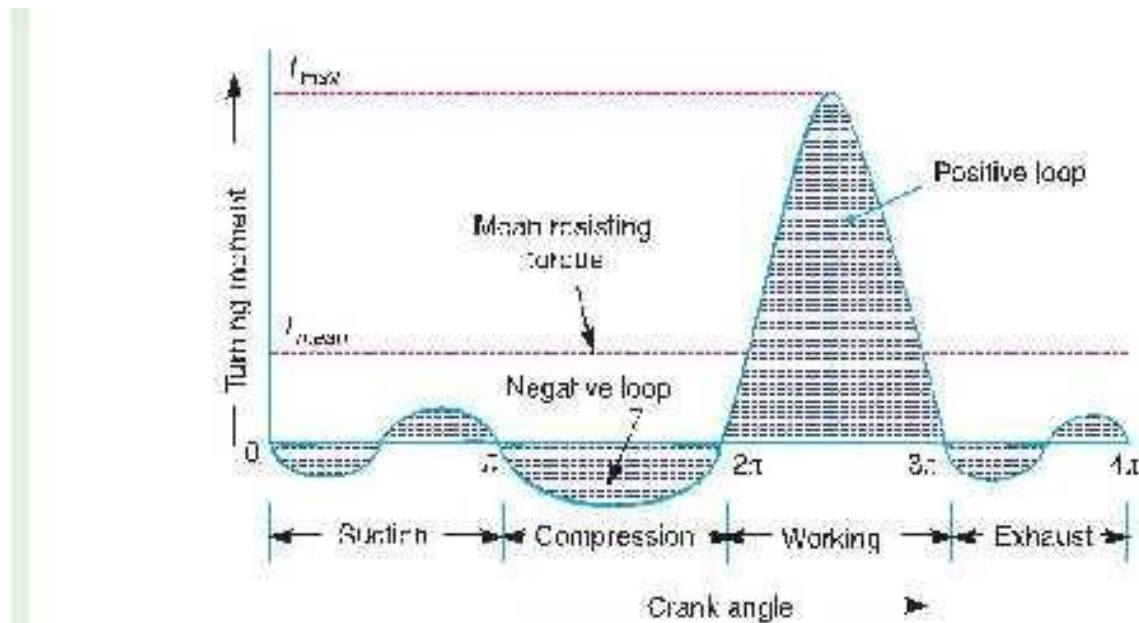

**Fig. 2.** Turning moment diagram for a four stroke cycle internal combustion engine.

Since the pressure inside the engine cylinder is less than the atmospheric pressure during the suction stroke, therefore a negative loop is formed as shown in Fig. 16.2. During the compression stroke, the work is done on the gases, therefore a higher negative loop is obtained. During the expansion or working stroke, the fuel burns and the gases expand, therefore a large positive loop is obtained. In this stroke, the work is done by the gases. During exhaust stroke, the work is done on the gases, therefore a negative loop is formed. It may be noted that the effect of the inertia forces on the piston is taken into account in Fig. 2.

### Turning Moment Diagram for a Multi-cylinder Engine

A separate turning moment diagram for a compound steam engine having three cylinders and the resultant turning moment diagram is shown in Fig. 16.3. The resultant turning moment diagram is the sum of the turning moment diagrams for the three cylinders. It may be noted that the first cylinder is the high pressure cylinder, second cylinder is the intermediate cylinder and the third cylinder is the

low pressure cylinder. The cranks, in case of three cylinders, are usually placed at  $120^\circ$  to each other.

## FLUCTUATION OF ENERGY

The fluctuation of energy may be determined by the turning moment diagram for one complete cycle

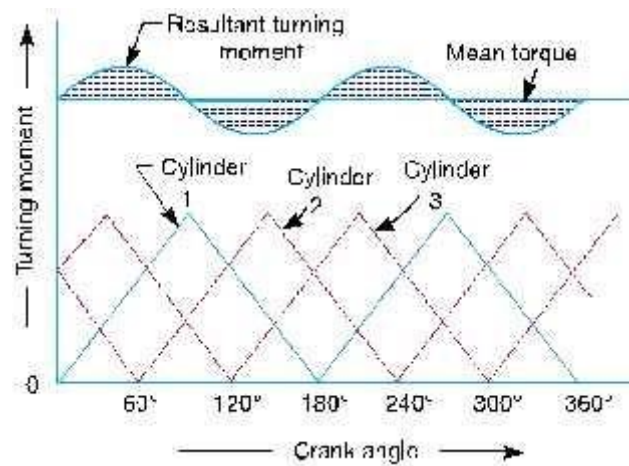

of operation. Consider the turning moment diagram for a single cylinder double acting steam engine as shown in Fig. 16.1. We see that the mean resisting torque line  $AF$  cuts the turning moment diagram at points  $B, C, D$  and  $E$ . When the crank moves from  $a$  to  $p$ , the work done by the engine is equal to the area  $aBp$ , whereas the energy required is represented by the area  $aABp$ . In other words, the engine has done less work (equal to the area  $aAB$ ) than the requirement. This amount of energy is taken from the flywheel and hence the speed of the flywheel decreases. Now the crank moves from  $p$  to  $q$ , the work done by the engine is equal to the area  $pBbCq$ , whereas the requirement of energy is represented by the area  $pBCq$ . Therefore, the engine has done more work than the requirement. This excess work (equal to the area  $BbC$ ) is stored in the flywheel and hence the speed of the flywheel increases while the crank moves from  $p$  to  $q$ .

Similarly, when the crank moves from  $q$  to  $r$ , more work is taken from the engine than is developed. This loss of work is represented by the area  $CcD$ . To supply this loss, the flywheel gives up some of its energy and thus the speed decreases while the crank moves from  $q$  to  $r$ . As the crank moves from  $r$  to  $s$ , excess energy is again developed given by the area  $DdE$  and the speed again increases. As the piston moves from  $s$  to  $e$ , again there is a loss of work and the speed decreases. The variations of energy above and below the mean resisting torque line are called **fluctuations of energy**. The areas  $BbC, CcD, DdE$ , etc. represent fluctuations of energy.

A little consideration will show that the engine has a maximum speed either at  $q$  or at  $s$ . This is due to the fact that the flywheel absorbs energy while the crank moves from  $p$  to  $q$  and from  $r$  to  $s$ . On the

other hand, the engine has a minimum speed either at  $p$  or at  $r$ . The reason is that the flywheel gives out some of its energy when the crank moves from  $a$  to  $p$  and  $q$  to  $r$ . The difference between the maximum and the minimum energies is known as *maximum fluctuation of energy*.

### Determination of Maximum Fluctuation of Energy

A turning moment diagram for a multi-cylinder engine is shown by a wavy curve in Fig. 4. The horizontal line  $A G$  represents the mean torque line. Let  $a_1, a_3, a_5$  be the areas above the mean torque line and  $a_2, a_4$  and  $a_6$  be the areas below the mean torque line. These areas represent some quantity of energy which is either added or subtracted from the energy of the moving parts of the engine

Let the energy in the flywheel at  $A = E$ , then from Fig. 16.4, we have Energy at  $B = E + a_1$

Energy at  $C = E + a_1 - a_2$

Energy at  $D = E + a_1 - a_2 + a_3$  Energy at  $E = E + a_1 - a_2 + a_3 - a_4$

Energy at  $F = E + a_1 - a_2 + a_3 - a_4 + a_5$  Energy at  $G = E + a_1 - a_2 + a_3 - a_4 + a_5 - a_6$

= Energy at  $A$  (*i.e.* cycle repeats after  $G$ )

Let us now suppose that the greatest of these energies is at  $B$  and least at  $E$ . Therefore, Maximum energy in flywheel

=  $E + a_1$  Minimum energy in the flywheel

=  $E + a_1 - a_2 + a_3 - a_4$

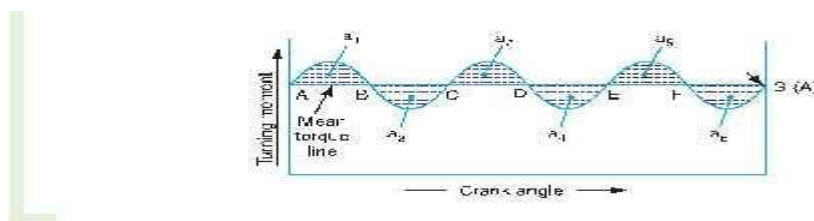

**Fig. 4.** Determination of maximum fluctuation of energy.

### FLYWHEEL

A flywheel used in machines serves as a reservoir, which stores energy during the period when the supply of energy is more than the requirement, and releases it during the period when the requirement of energy is more than the supply.

In case of steam engines, internal combustion engines, reciprocating compressors and pumps, the energy is developed during one stroke and the engine is to run for the whole cycle on the energy produced during this one stroke. For example, in internal combustion engines, the energy is developed only during expansion or power stroke which is much more than the engine load and no energy is being developed during suction, compression and exhaust strokes in case of four stroke engines and during compression in case of two stroke engines. The excess energy developed during power stroke is absorbed by the flywheel and releases it to the crankshaft during other strokes in which no energy is developed, thus rotating the crankshaft at a uniform speed. A little consideration will show that when the flywheel absorbs energy, its speed increases and when it releases energy, the speed decreases. Hence a flywheel does not maintain a constant speed, it simply reduces the fluctuation of speed. In other words, a flywheel controls the speed variations caused by the fluctuation of the engine turning moment during each cycle of operation.

In machines where the operation is intermittent like \*punching machines, shearing machines, rivetting machines, crushers, etc., the flywheel stores energy from the power source during the greater portion of the operating cycle and gives it up during a small period of the cycle. Thus, the energy from the power source to the machines is supplied practically at a constant rate throughout the operation.

### COEFFICIENT OF FLUCTUATION OF SPEED

The difference between the maximum and minimum speeds during a cycle is called the maximum fluctuation of speed. The ratio of the maximum fluctuation of speed to the mean speed is called the coefficient of fluctuation of speed.

Let  $N_1$  and  $N_2$  = Maximum and minimum speeds in r.p.m. during the cycle

$$N - \text{Mean speed in r.p.m.} = \frac{N_1 + N_2}{2}$$

∴ Coefficient of fluctuation of speed,

$$C_s = \frac{N_1 - N_2}{N} = \frac{2(N_1 - N_2)}{N_1 + N_2}$$

$$= \frac{\omega_1 - \omega_2}{\omega} = \frac{2(\omega_1 - \omega_2)}{\omega_1 + \omega_2} \quad \dots(\text{In terms of angular speeds})$$

$$= \frac{v_1 - v_2}{v} = \frac{2(v_1 - v_2)}{v_1 + v_2} \quad \dots(\text{In terms of linear speeds})$$

The coefficient of fluctuation of speed is a limiting factor in the design of flywheel. It varies



depending upon the nature of service to which the flywheel is employed.

### ENERGY STORED IN A FLYWHEEL

$I$  = Mass moment of inertia of the flywheel about its axis of rotation  
in  $\text{kg}\cdot\text{m}^2 = m\cdot k^2$ ,

$N_1$  and  $N_2$  = Maximum and minimum speeds during the cycle in r.p.m.,

$\omega_1$  and  $\omega_2$  = Maximum and minimum angular speeds during the cycle in rad/s,

$$N = \text{Mean speed during the cycle in r.p.m.} = \frac{N_1 + N_2}{2},$$

$$\omega = \text{Mean angular speed during the cycle in rad/s} = \frac{\omega_1 + \omega_2}{2},$$

$$C_s = \text{Coefficient of fluctuation of speed} = \frac{N_1 - N_2}{N} \text{ or } \frac{\omega_1 - \omega_2}{\omega}$$

Let  $m$  = Mass of the flywheel in kg,

$k$  = Radius of gyration of the flywheel in metres,

The turning moment diagram for a multi-cylinder engine has been drawn to a scale of 1 mm to 500 N-m torque and 1 mm to  $6^\circ$  of crank displacement. The intercepted areas between output torque curve and mean resistance line taken in order from one end, in sq. mm are  $-30, +410, -280, +320, -330, +250, -360, +280, -260$  sq. mm, when the engine is running at 800 r.p.m. The engine has a stroke of 300 mm and the fluctuation of speed is not to exceed  $\pm 2\%$  of the mean speed. Determine a suitable diameter and cross-section of the flywheel rim for a limiting value of the safe centrifugal stress of 7 MPa. The material density may be assumed as  $7200 \text{ kg/m}^3$ . The width of the rim is to be 5 times the thickness.

and coefficient of fluctuation of speed,

$$C_s = \frac{\omega_1 - \omega_2}{\omega} = 0.04$$

*Diameter of the flywheel rim*

Let  $D$  = Diameter of the flywheel rim in metres, and  
 $v$  = Peripheral velocity of the flywheel rim in m/s.

We know that centrifugal stress ( $\sigma$ ),

$$7 \times 10^6 = \rho \cdot v^2 = 7200 v^2 \text{ or } v^2 = 7 \times 10^6 / 7200 = 972.2$$

$$\therefore v = 31.2 \text{ m/s}$$

We know that  $v = \pi D N / 60$

$$\therefore D = v \times 60 / \pi N = 31.2 \times 60 / \pi \times 800 = 0.745 \text{ m Ans.}$$

**Solution.** Given :  $N = 800$  r.p.m. or  $\omega = 2\pi \times 800 / 60 = 83.8$  rad/s; \*Stroke = 300 mm ;

$$\sigma = 7 \text{ MPa} = 7 \times 10^6 \text{ N/m}^2 ; \rho = 7200 \text{ kg/m}^3$$

Since the fluctuation of speed is  $\pm 2\%$  of mean speed, therefore total fluctuation of

**Cross-section of the flywheel rim**

Let  $t$  = Thickness of the flywheel rim in metres, and  
 $b$  = Width of the flywheel rim in metres =  $5t$  ... (Given)  
 $\therefore$  Cross-sectional area of flywheel rim,  
 $A = b \cdot t = 5t \times t = 5t^2$

First of all, let us find the mass ( $m$ ) of the flywheel rim. The turning moment diagram is shown in Fig 16.18.

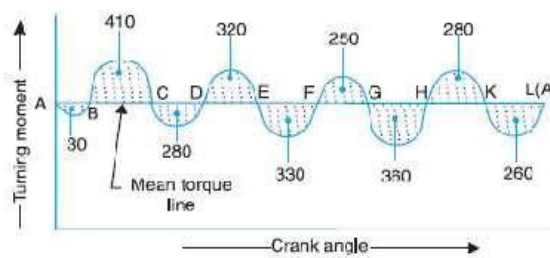

Fig. 16.18

Since the turning moment scale is  $1 \text{ mm} = 500 \text{ N-m}$  and crank angle scale is  $1 \text{ mm} = 6^\circ = \pi/30 \text{ rad}$ , therefore

$$\omega_1 - \omega_2 = 4\% \omega = 0.04 \omega$$

The turning moment diagram of a four stroke engine may be assumed for the sake of simplicity to be represented by four triangles in each stroke. The areas of these triangles are as follows:

Suction stroke =  $5 \times 10^{-5} \text{ m}^2$ . Compression stroke =  $21 \times 10^{-5} \text{ m}^2$ . Expansion stroke =  $21 \times 10^{-5} \text{ m}^2$ . Exhaust stroke =  $5 \times 10^{-5} \text{ m}^2$ .  
 Let the energy at  $A = E$ , then referring to Fig 16.18,

Energy at  $B = E - 30$  (Minimum energy)  
 Energy at  $C = E - 30 + 410 = E + 380$   
 Energy at  $D = E + 380 - 280 = E + 100$   
 Energy at  $E = E + 100 + 320 = E + 420$  (Maximum energy)  
 Energy at  $F = E + 420 - 330 = E + 90$   
 Energy at  $G = E + 90 + 250 = E + 340$   
 Energy at  $H = E + 340 - 360 = E - 20$

$$\Delta E = \text{Maximum energy} - \text{Minimum energy} \\ = (E + 420) - (E - 30) = 450 \text{ mm}^2 \\ = 450 \times 52.37 = 23566 \text{ N-m}$$

We also know that maximum fluctuation of energy ( $\Delta E$ ),

$$23566 = m \cdot v^2 \cdot C_s = m \times (31.2)^2 \times 0.04 = 39 m$$

$$\therefore m = 23566 / 39 = 604 \text{ kg}$$

We know that mass of the flywheel rim ( $m$ ),

$$604 = \text{Volume} \times \text{density} = \pi D A \rho \\ = \pi \times 0.745 \times 5t^2 \times 7200 = 84268 t^2$$

$$\therefore t^2 = 604 / 84268 = 0.00717 \text{ m}^2 \text{ or } t = 0.085 \text{ m} = 85 \text{ mm Ans.}$$

and

$$b = 5t = 5 \times 85 = 425 \text{ mm Ans.}$$

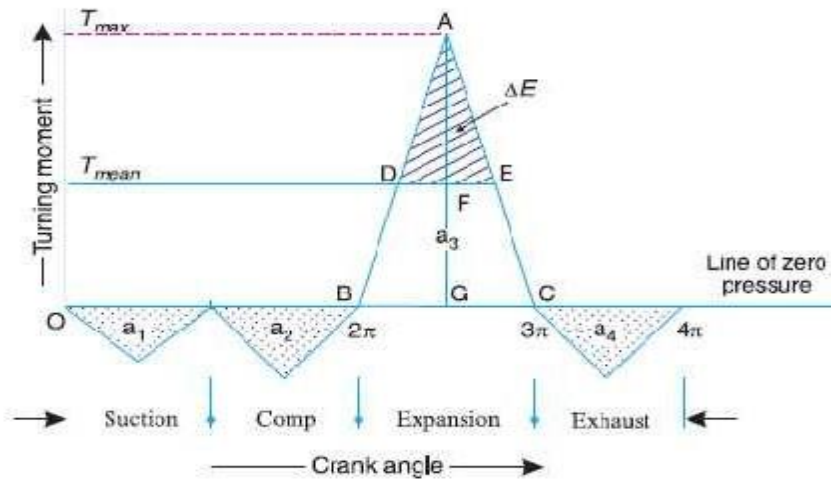

Fig. 16.20

$$\begin{aligned} \therefore \text{Net area} &= a_3 - (a_1 + a_2 + a_4) \\ &= 85 \times 10^5 - (5 \times 10^5 + 21 \times 10^5 + 8 \times 10^5) = 51 \times 10^5 \text{ m}^2 \end{aligned}$$

Since  $1 \text{ m}^2 = 14 \text{ MN-m} = 14 \times 10^6 \text{ N-m}$  of work, therefore

Net work done per cycle

$$= 51 \times 10^5 \times 14 \times 10^6 = 7140 \text{ N-m} \quad \dots(i)$$

We also know that work done per cycle

$$= T_{\text{mean}} \times 4\pi \text{ N-m} \quad \dots(ii)$$

From equation (i) and (ii),

$$T_{\text{mean}} = FG = 7140 / 4\pi = 568 \text{ N-m}$$

Work done during expansion stroke

$$= a_3 \times \text{Work scale} = 85 \times 10^5 \times 14 \times 10^6 = 11900 \text{ N-m} \quad \dots(iii)$$

Also, work done during expansion stroke

$$= \frac{1}{2} \times BC \times AG = \frac{1}{2} \times \pi \times AG = 1.571 AG \quad \dots(iv)$$

From equations (iii) and (iv),

$$AG = 11900 / 1.571 = 7575 \text{ N-m}$$

$$\therefore \text{Excess torque} = AF = AG - FG = 7575 - 568 = 7007 \text{ N-m}$$

Now from similar triangles  $ADE$  and  $ABC$ ,

$$\frac{DE}{BC} = \frac{AF}{AG} \quad \text{or} \quad DE = \frac{AF}{AG} \times BC = \frac{7007}{7575} \times \pi = 2.9 \text{ rad}$$

We know that maximum fluctuation of energy,

$$\begin{aligned} \Delta E &= \text{Area of } \triangle ADE = \frac{1}{2} \times DE \times AI' \\ &= \frac{1}{2} \times 2.9 \times 7007 = 10\,160 \text{ N-m} \end{aligned}$$

### Moment of Inertia of the flywheel

Let  $I$  = Moment of inertia of the flywheel in  $\text{kg-m}^2$ .

We know that mean speed during the cycle

$$N = \frac{N_1 + N_2}{2} = \frac{102 + 98}{2} = 100 \text{ r.p.m.}$$

$\therefore$  Corresponding angular mean speed,

$$\omega = 2\pi N / 60 = 2\pi \times 100 / 60 = 10.47 \text{ rad/s}$$

and coefficient of fluctuation of speed,

$$C_s = \frac{N_1 - N_2}{N} = \frac{102 - 98}{100} = 0.04$$

We know that maximum fluctuation of energy ( $\Delta E$ ),

$$10\,160 = I\omega^2 C_s = I(10.47)^2 \times 0.04 = 4.385 I$$

$$\therefore I = 10160 / 4.385 = 2317 \text{ kg m}^2 \text{ Ans.}$$

### Size of flywheel

Let  $t$  = Thickness of the flywheel rim in metres,

$b$  = Width of the flywheel rim in metres =  $4t$  ... (Given)

$D$  = Mean diameter of the flywheel in metres, and

$v$  = Peripheral velocity of the flywheel in m/s.

We know that hoop stress ( $\sigma$ ),

$$7.5 \times 10^6 = \rho \cdot v^2 = 8150 v^2$$

$$\therefore v^2 = \frac{7.5 \times 10^6}{8150} = 920 \quad \text{or} \quad v = 30.3 \text{ m/s}$$

and  $v = \pi DN / 60$  or  $D = v \times 60 / \pi N = 30.3 \times 60 / \pi \times 100 = 5.786 \text{ m}$

Also  $m = \text{Volume} \times \text{density} = \pi D \times A \times \frac{\rho}{g} = \pi D \times b \times t \times \frac{\rho}{g}$

$$276.7 = \pi \times 5.786 \times 4t \times t \times \frac{8 \times 10^4}{9.81} = 59.3 \times 10^4 t^2$$

$$\therefore t^2 = 276.7 / 59.3 \times 10^4 = 0.0216 \text{ m or } 21.6 \text{ mm Ans.}$$

and  $b = 4t = 4 \times 21.6 = 86.4 \text{ mm Ans.}$

## **INTRODUCTION TO GOVERNOR:**

A **centrifugal governor** is a specific type of governor that controls the speed of an engine by regulating the amount of fuel (or working fluid) admitted, so as to maintain a near constant speed whatever the load or fuel supply conditions. It uses the principle of proportional control.

It is most obviously seen on steam engines where it regulates the admission of steam into the cylinder(s). It is also found on internal combustion engines and variously fuelled turbines, and in some modern striking clocks.

## **PRINCIPLE OF WORKING:**

Power is supplied to the governor from the engine's output shaft by (in this instance) a belt or chain (not shown) connected to the lower belt wheel. The governor is connected to a throttle valve that regulates the flow of working fluid (steam) supplying the prime mover (prime mover not shown). As the speed of the prime mover increases, the central spindle of the governor rotates at a faster rate and the kinetic energy of the balls increases. This allows the two masses on lever arms to move outwards and upwards against gravity. If the motion goes far enough, this motion causes the lever arms to pull down on a thrust bearing, which moves a beam linkage, which reduces the aperture of a throttle valve. The rate of working-fluid entering the cylinder is thus reduced and the speed of the prime mover is controlled, preventing over speeding.

Mechanical stops may be used to limit the range of throttle motion, as seen near the masses in the image at right.

The direction of the lever arm holding the mass will be along the vector sum of the reactive centrifugal force vector and the gravitational force.

## **UNIT –IV**

### **BALANCING**

#### **INTRODUCTION:**

Balancing is the process of eliminating or at least reducing the ground forces and/or moments. It is achieved by changing the location of the mass centres of links. Balancing of rotating parts is a well known problem. A rotating body with fixed rotation axis can be fully balanced i.e. all the inertia forces and moments. For mechanism containing links rotating about axis which are not fixed, force balancing is possible, moment balancing by itself may be possible, but both not possible. We generally try to do force balancing. A fully force balance is possible, but any action in force balancing severe the moment balancing.

#### **BALANCING OF ROTATING MASSES:**

The process of providing the second mass in order to counteract the effect of the centrifugal force of the first mass is called balancing of rotating masses.

#### **Static balancing:**

The net dynamic force acting on the shaft is equal to zero. This requires that the line of action of three centrifugal forces must be the same. In other words, the centre of the masses of the system must lie on the axis of the rotation. This is the condition for static balancing.

#### **Dynamic balancing:**

The net couple due to dynamic forces acting on the shaft is equal to zero. The algebraic sum of the moments about any point in the plane must be zero.

#### **Various cases of balancing of rotating masses:**

- i. Balancing of a single rotating mass by single mass rotating in the same plane.
- ii. Balancing of a single rotating mass by two masses rotating in the different plane.
- iii. Balancing of a several masses rotating in single plane.
- iv. Balancing of a several masses rotating in different planes.

## BALANCING OF A SINGLE ROTATING MASS BY SINGLE MASS ROTATING IN THE

### SAME PLANE:

Consider a disturbing mass  $m_1$  attached to a shaft rotating at  $\omega$  rad/s as shown in Fig. Let  $r_1$  be the radius of rotation of the mass  $m_1$  (i.e. distance between the axis of rotation of the shaft and the centre of gravity of the mass  $m_1$ ).

We know that the centrifugal force exerted by the mass  $m_1$  on the shaft,

$$F_{C1} = m_1 \cdot \omega^2 \cdot r_1 \quad \dots (i)$$

This centrifugal force acts radially outwards and thus produces bending moment on the shaft. In order to counteract the effect of this force, a balancing mass ( $m_2$ ) may be attached in the same plane of rotation as that of disturbing mass ( $m_1$ ) such that the centrifugal forces due to the two masses are equal and opposite.

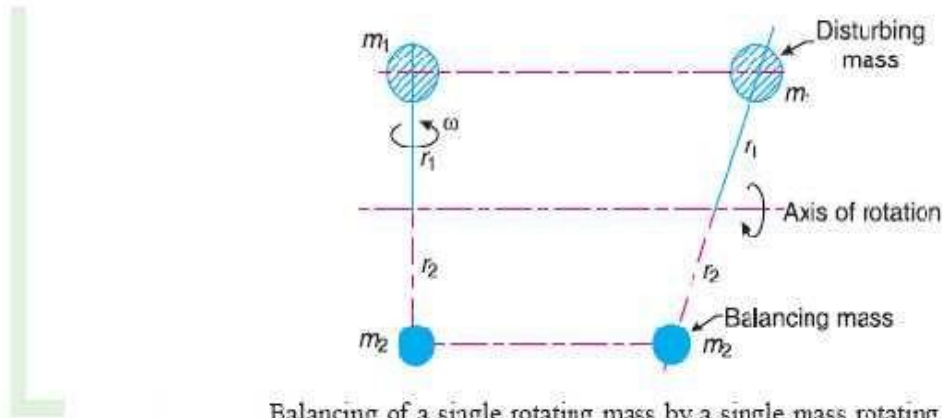

Balancing of a single rotating mass by a single mass rotating in the same plane.

Let  $r_2$  – Radius of rotation of the balancing mass  $m_2$  (i.e. distance between the axis of rotation of the shaft and the centre of gravity of mass  $m_2$ ).

$\therefore$  Centrifugal force due to mass  $m_2$ ,

$$F_{C2} = m_2 \cdot \omega^2 \cdot r_2 \quad \dots (ii)$$

Equating equations (i) and (ii),

$$m_1 \cdot \omega^2 \cdot r_1 = m_2 \cdot \omega^2 \cdot r_2 \quad \text{or} \quad m_1 \cdot r_1 = m_2 \cdot r_2$$

**Notes :** 1. The product  $m_2 \cdot r_2$  may be split up in any convenient way. But the radius of rotation of the balancing mass ( $m_2$ ) is generally made large in order to reduce the balancing mass  $m_2$ .

2. The centrifugal forces are proportional to the product of the mass and radius of rotation of respective masses, because  $\omega^2$  is same for each mass.

## BALANCING OF A SINGLE ROTATING MASS BY TWO MASSES ROTATING IN THE DIFFERENT PLANE:

We have discussed in the previous article that by introducing a single balancing mass in the same plane of rotation as that of disturbing mass, the centrifugal forces are balanced. In other words, the two forces are equal in magnitude and opposite in direction. But this type of arrangement for balancing gives rise to a couple which tends to rock the shaft in its bearings. Therefore in order to put the system in complete balance, two balancing masses are placed in two different planes, parallel to the plane of rotation of the disturbing mass, in such a way that they satisfy the following two conditions of equilibrium.

1. The net dynamic force acting on the shaft is equal to zero. This requires that the line of action of three centrifugal forces must be the same. In other words, the centre of the masses of the system must lie on the axis of rotation. This is the condition for *static balancing*.
2. The net couple due to the dynamic forces acting on the shaft is equal to zero. In other words, the algebraic sum of the moments about any point in the plane must be zero.

The conditions (1) and (2) together give *dynamic balancing*. The following two possibilities-

Let

$l_1$  = Distance between the planes  $A$  and  $L$ ,

$l_2$  = Distance between the planes  $A$  and  $M$ , and

$l$  = Distance between the planes  $L$  and  $M$ .

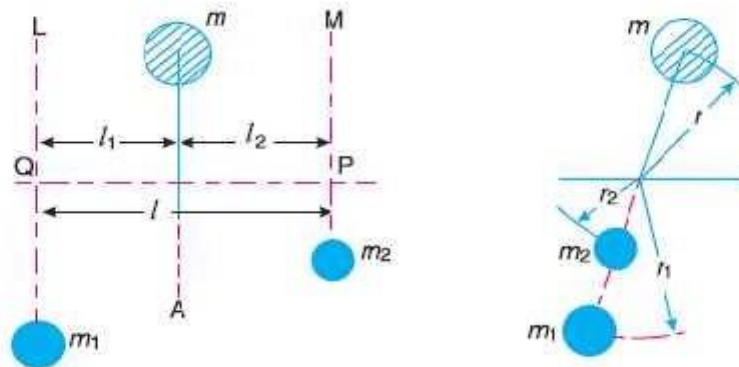

**Fig. 21.2.** Balancing of a single rotating mass by two rotating masses in different planes when the plane of single rotating mass lies in between the planes of two balancing masses.

We know that the centrifugal force exerted by the mass  $m$  in the plane  $A$ ,

$$F_C = m \cdot \omega^2 \cdot r$$

Similarly, the centrifugal force exerted by the mass  $m_1$  in the plane  $L$ ,

$$F_{C1} = m_1 \cdot \omega^2 \cdot r_1$$

and, the centrifugal force exerted by the mass  $m_2$  in the plane  $M$ ,

$$F_{C2} = m_2 \cdot \omega^2 \cdot r_2$$

Since the net force acting on the shaft must be equal to zero, therefore the centrifugal force on the disturbing mass must be equal to the sum of the centrifugal forces on the balancing masses, therefore



## BALANCING OF A SEVERAL MASSES ROTATING IN SAME PLANE:

The magnitude and position of the balancing mass may be found out analytically or graphically as discussed below :

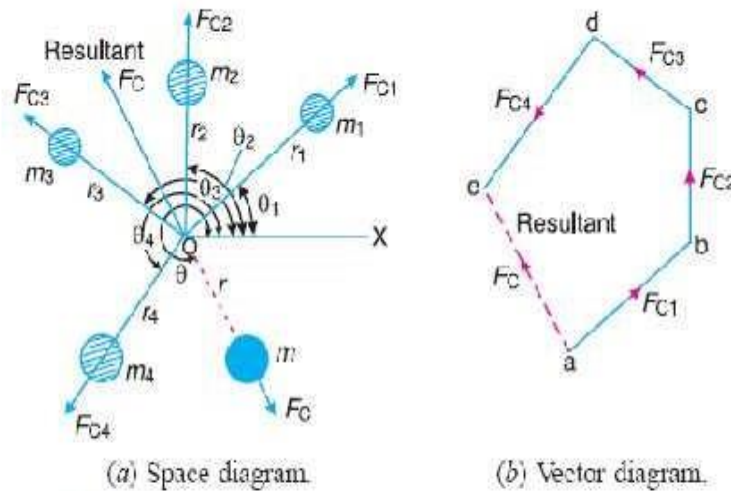

Fig. 21.4. Balancing of several masses rotating in the same plane.

### 1. Analytical method

The magnitude and direction of the balancing mass may be obtained, analytically, as discussed below :

1. First of all, find out the centrifugal force\* (or the product of the mass and its radius of rotation) exerted by each mass on the rotating shaft.

2. Resolve the centrifugal forces horizontally and vertically and find their sums, i.e.  $\Sigma H$  and  $\Sigma V$ . We know that

Sum of horizontal components of the centrifugal forces,

$$\Sigma H = m_1 \cdot r_1 \cos \theta_1 + m_2 \cdot r_2 \cos \theta_2 + \dots$$

and sum of vertical components of the centrifugal forces,

$$\Sigma V = m_1 \cdot r_1 \sin \theta_1 + m_2 \cdot r_2 \sin \theta_2 + \dots$$

3. Magnitude of the resultant centrifugal force,

$$F_C = \sqrt{(\Sigma H)^2 + (\Sigma V)^2}$$

4. If  $\theta$  is the angle, which the resultant force makes with the horizontal, then

$$\tan \theta = \Sigma V / \Sigma H$$

5. The balancing force is then equal to the resultant force, but in *opposite direction*.

6. Now find out the magnitude of the balancing mass, such that

$$F_C = m \cdot r$$

where

$m$  = Balancing mass, and

$r$  = Its radius of rotation.

## 2. Graphical method

The magnitude and position of the balancing mass may also be obtained graphically as discussed below :

1. First of all, draw the space diagram with the positions of the several masses, as shown in Fig.
2. Find out the centrifugal force (or product of the mass and radius of rotation) exerted by each mass on the rotating shaft.
3. Now draw the vector diagram with the obtained centrifugal forces (or the product of the masses and their radii of rotation), such that  $ab$  represents the centrifugal force exerted by the mass  $m_1$  (or  $m_1 \cdot r_1$ ) in magnitude and direction to some suitable scale. Similarly, draw  $bc$ ,  $cd$  and  $de$  to represent centrifugal forces of other masses  $m_2$ ,  $m_3$  and  $m_4$  (or  $m_2 \cdot r_2$ ,  $m_3 \cdot r_3$  and  $m_4 \cdot r_4$ ).
4. Now, as per polygon law of forces, the closing side  $ae$  represents the resultant force in magnitude and direction, as shown in Fig.
5. The balancing force is, then, equal to the resultant force, but in *opposite direction*.
6. Now find out the magnitude of the balancing mass ( $m$ ) at a given radius of rotation ( $r$ ), such that

$$m \cdot \omega^2 \cdot r = \text{Resultant centrifugal force}$$

or

$$m \cdot r = \text{Resultant of } m_1 \cdot r_1, m_2 \cdot r_2, m_3 \cdot r_3 \text{ and } m_4 \cdot r_4$$

## BALANCING OF SEVERAL MASSES ROTATING DIFFERENT PLANE:

When several masses revolve in different planes, they may be transferred to a *reference plane* (briefly written as *R.P.*), which may be defined as the plane passing through a point on the axis of rotation and perpendicular to it. The effect of transferring a revolving mass (in one plane) to a reference plane is to cause a force of magnitude equal to the centrifugal force of the revolving mass to act in the reference plane, together with a couple of magnitude equal to the product of the force and the distance between the plane of rotation and the reference plane. In order to have a complete balance of the several revolving masses in different planes, the following two conditions must be satisfied :

1. The forces in the reference plane must balance, *i.e.* the resultant force must be zero.
2. The couples about the reference plane must balance, *i.e.* the resultant couple must be zero.

Let us now consider four masses  $m_1$ ,  $m_2$ ,  $m_3$  and  $m_4$  revolving in planes 1, 2, 3 and 4 respectively as shown in

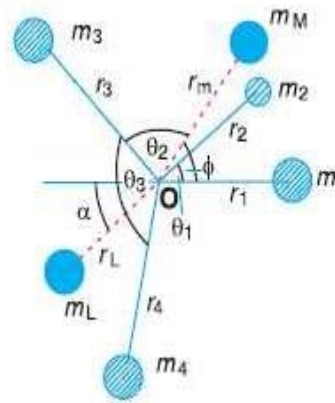
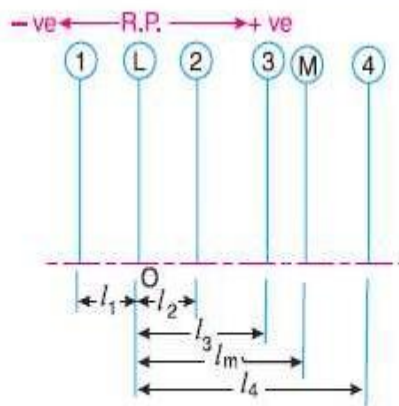

Fig. (a). The relative angular positions of these masses are shown in the end view [Fig. 21.7 (b)]. The magnitude of the balancing masses  $m_L$  and  $m_M$  in planes  $L$  and  $M$  may be obtained as discussed below :

1. Take one of the planes, say  $L$  as the reference plane (*R.P.*). The distances of all the other planes to the left of the reference plane may be regarded as *negative*, and those to the right as *positive*.
  2. Tabulate the data as shown in Table 21.1. The planes are tabulated in the same order in which they occur, reading from left to right.
-

**Table 21.1**

Plane	Mass ( $m$ )	Radius( $r$ )	Cent.force $\div \omega^2$	Distance from Plane L ( $l$ )	Couple $\div \omega^2$
(1)	(2)	(3)	( $m.r$ ) (4)	(5)	( $m.r.l$ ) (6)
1	$m_1$	$r_1$	$m_1.r_1$	$-l_1$	$-m_1.r_1.l_1$
L(R.P.)	$m_L$	$r_L$	$m_L.r_L$	0	0
2	$m_2$	$r_2$	$m_2.r_2$	$l_2$	$m_2.r_2.l_2$
3	$m_3$	$r_3$	$m_3.r_3$	$l_3$	$m_3.r_3.l_3$
M	$m_M$	$r_M$	$m_M.r_M$	$l_M$	$m_M.r_M.l_M$
4	$m_4$	$r_4$	$m_4.r_4$	$l_4$	$m_4.r_4.l_4$



(a) Position of planes of the masses. (b) Angular position of the masses.

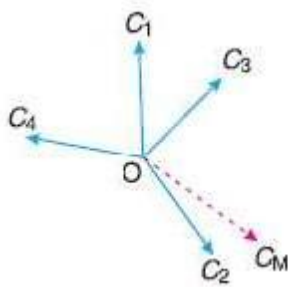

(c) Couple vector.

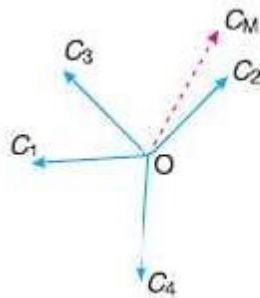

(d) Couple vectors turned counter clockwise through a right angle.

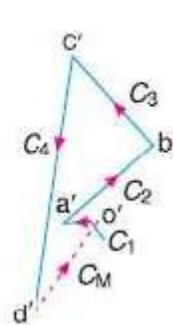

(e) Couple polygon.

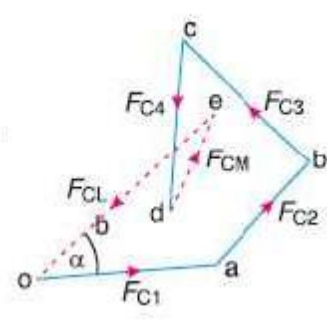

(f) Force polygon.

**Fig.** Balancing of several masses rotating in different planes.

3. A couple may be represented by a vector drawn perpendicular to the plane of the couple. The couple  $C_1$  introduced by transferring  $m_1$  to the reference plane through O is propor-

tional to  $m_1 r_1 l_1$  and acts in a plane through  $Om_1$  and perpendicular to the paper. The vector representing this couple is drawn in the plane of the paper and perpendicular to  $Om_1$  as shown by  $OC_1$  in Fig. (c). Similarly, the vectors  $OC_2$ ,  $OC_3$  and  $OC_4$  are drawn perpendicular to  $Om_2$ ,  $Om_3$  and  $Om_4$  respectively and in the plane of the paper.

4. The couple vectors as discussed above, are turned counter clockwise through a right angle for convenience of drawing as shown in Fig. 21.7 (d). We see that their relative positions remains unaffected. Now the vectors  $OC_2$ ,  $OC_3$  and  $OC_4$  are parallel and in the same direction as  $Om_2$ ,  $Om_3$  and  $Om_4$ , while the vector  $OC_1$  is parallel to  $Om_1$  but in opposite direction. Hence the *couple vectors are drawn radially outwards for the masses on one side of the reference plane and radially inward for the masses on the other side of the reference plane.*

5. Now draw the couple polygon as shown in Fig. (e). The vector  $d'o'$  represents the balanced couple. Since the balanced couple  $C_M$  is proportional to  $m_M r_M l_M$ , therefore

$$C_M = m_M \cdot r_M \cdot l_M = \text{vector } d'o' \quad \text{or} \quad m_M = \frac{\text{vector } d'o'}{r_M \cdot l_M}$$

From this expression, the value of the balancing mass  $m_M$  in the plane  $M$  may be obtained, and the angle of inclination  $\phi$  of this mass may be measured from Fig. 21.7 (b).

6. Now draw the force polygon as shown in Fig. (f). The vector  $eo$  (in the direction from  $e$  to  $o$ ) represents the balanced force. Since the balanced force is proportional to  $m_L r_L$ , therefore,

$$m_L \cdot r_L = \text{vector } eo \quad \text{or} \quad m_L = \frac{\text{vector } eo}{r_L}$$

From this expression, the value of the balancing mass  $m_L$  in the plane  $L$  may be obtained the angle of inclination  $\alpha$  of this mass with the horizontal may be measured from Fig. (b).

### BALANCING OF RECIPROCATING MASSES:

Mass balancing encompasses a wide array of measures employed to obtain partial or complete compensation for the inertial forces and moments of inertia emanating from the crankshaft assembly. All masses are externally balanced when no free inertial forces or moments of inertia are transmitted through the block to the outside. However, the remaining internal forces and moments subject the engine mounts and block to various loads as well as deformities and vibratory stresses. The basic loads imposed by gas-based and inertial forces.

**Primary and secondary unbalanced forces of reciprocating parts:**

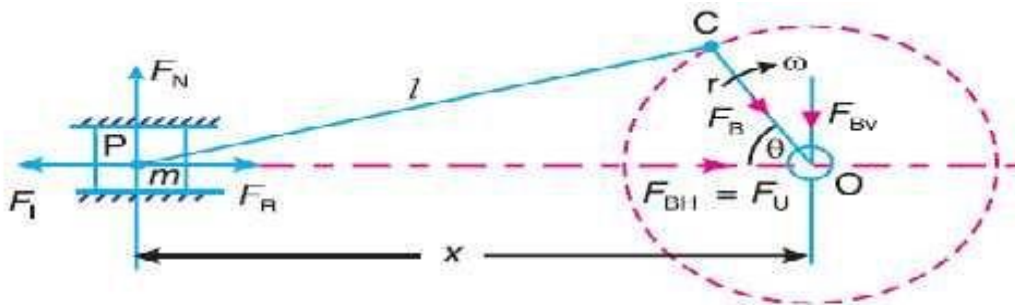

**Reciprocating engine mechanism.**

Let  $F_R$  = Force required to accelerate the reciprocating parts.

- Let
- $m$  – Mass of the reciprocating parts,
  - $l$  = Length of the connecting rod  $PC$ ,
  - $r$  = Radius of the crank  $OC$ ,
  - $\theta$  = Angle of inclination of the crank with the line of stroke  $PO$ ,
  - $\omega$  = Angular speed of the crank,
  - $n$  = Ratio of length of the connecting rod to the crank radius =  $l/r$ .

We have already discussed in Art. 15.8 that the acceleration of the reciprocating parts is approximately given by the expression,

$$a_R = \omega^2 \cdot r \left( \cos \theta + \frac{\cos 2\theta}{n} \right)$$

$\therefore$  Inertia force due to reciprocating parts or force required to accelerate the reciprocating parts,

$$F_I = F_R = \text{Mass} \times \text{acceleration} = m \cdot \omega^2 \cdot r \left( \cos \theta + \frac{\cos 2\theta}{n} \right)$$

We have discussed in the previous article that the horizontal component of the force exerted on the crank shaft bearing (*i.e.*  $F_{BH}$ ) is equal and opposite to inertia force ( $F_I$ ). This force is an unbalanced one and is denoted by  $F_U$ .

$\therefore$  Unbalanced force,

$$F_U = m \cdot \omega^2 \cdot r \left( \cos \theta + \frac{\cos 2\theta}{n} \right) = m \cdot \omega^2 \cdot r \cos \theta + m \cdot \omega^2 \cdot r \times \frac{\cos 2\theta}{n} = F_P + F_S$$

The expression  $(m \cdot \omega^2 \cdot r \cos \theta)$  is known as *primary unbalanced force* and  $\left( m \cdot \omega^2 \cdot r \times \frac{\cos 2\theta}{n} \right)$  is called *secondary unbalanced force*.

## **BALANCING OF SINGLE CYLINDER ENGINE:**

A single cylinder engine produces three main vibrations. In describing them we will assume that the cylinder is vertical. Firstly, in an engine with no balancing counterweights, there would be an enormous vibration produced by the change in momentum of the piston, gudgeon pin, connecting rod and crankshaft once every revolution. Nearly all single-cylinder crankshafts incorporate balancing weights to reduce this. While these weights can balance the crankshaft completely, they cannot completely balance the motion of the piston, for two reasons. The first reason is that the balancing weights have horizontal motion as well as vertical motion, so balancing the purely vertical motion of the piston by a crankshaft weight adds a horizontal vibration. The second reason is that, considering now the vertical motion only, the smaller piston end of the connecting rod (little end) is closer to the larger crankshaft end (big end) of the connecting rod in mid-stroke than it is at the top or bottom of the stroke, because of the connecting rod's angle. So during the 180° rotation from mid-stroke through top-dead-center and back to mid-stroke the minor contribution to the piston's up/down movement from the connecting rod's change of angle has the same direction as the major contribution to the piston's up/down movement from the up/down movement of the crank pin. By contrast, during the 180° rotation from mid-stroke through bottom-dead-center and back to mid-stroke the minor contribution to the piston's up/down movement from the connecting rod's change of angle has the opposite direction of the major contribution to the piston's up/down movement from the up/down movement of the crank pin. The piston therefore travels faster in the top half of the cylinder than it does in the bottom half, while the motion of the crankshaft weights is sinusoidal. The vertical motion of the piston is therefore not quite the same as that of the balancing weight, so they can't be made to cancel out completely.

Secondly, there is a vibration produced by the change in speed and therefore kinetic energy of the piston. The crankshaft will tend to slow down as the piston speeds up and absorbs energy, and to speed up again as the piston gives up energy in slowing down at the top and bottom of the stroke. This vibration has twice the frequency of the first vibration, and absorbing it is one function of the flywheel.

Thirdly, there is a vibration produced by the fact that the engine is only producing power during the power stroke. In a four-stroke engine this vibration will have half the frequency of the first vibration,

as the cylinder fires once every two revolutions. In a two-stroke engine, it will have the same frequency as the first vibration. This vibration is also absorbed by the flywheel.

### PARTIAL BALANCING OF LOCOMOTIVES:

The locomotives, usually, have two cylinders with cranks placed at right angles to each other in order to have uniformity in turning moment diagram. The two cylinder locomotives may be classified as :

1. Inside cylinder locomotives ; and
2. Outside cylinder locomotives.

In the *inside cylinder locomotives*, the two cylinders are placed in between the planes of two driving wheels as shown in Fig. (a) ; whereas in the *outside cylinder locomotives*, the two cylinders are placed outside the driving wheels, one on each side of the driving wheel, as shown in Fig. (b). The locomotives may be

- (a) Single or uncoupled locomotives ; and
- (b) Coupled locomotives.

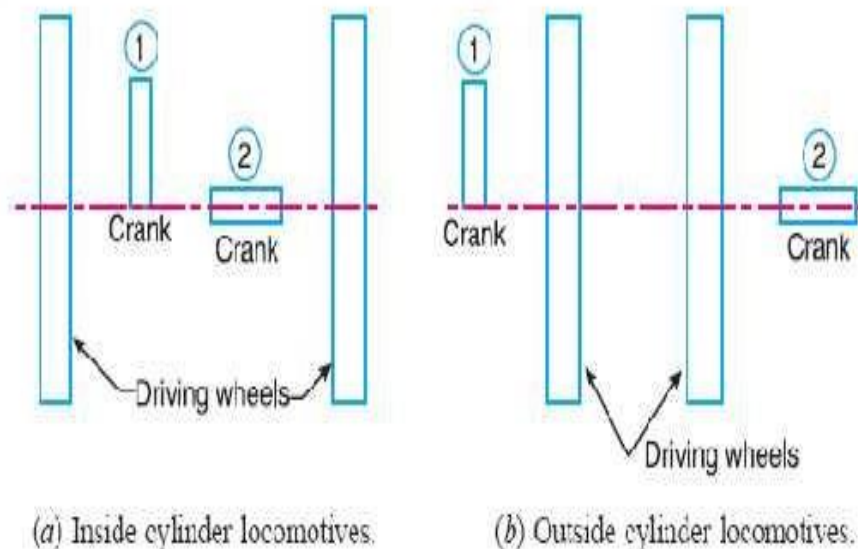

### Variation of Tractive force:

The resultant unbalanced force due to the cylinders, along the line of stroke, is known as tractive force.

### Swaying Couple:

The couple has swaying effect about a vertical axis, and tends to sway the engine alternately in clockwise and anticlockwise directions. Hence the couple is known as swaying couple.



The unbalanced forces along the line of stroke for the two cylinders constitute a couple about the centre line  $YY$  between the cylinders as shown in Fig. 22.5.

This couple has swaying effect about a vertical axis, and tends to sway the engine alternately in clockwise and anticlockwise directions. Hence the couple is known as *swaying couple*.

Let  $a$  = Distance between the centre lines of the two cylinders.

∴ Swaying couple

$$= (1-c)m\omega^2 r \cos \theta \times \frac{a}{2}$$

$$- (1-c)m\omega^2 r \cos (90^\circ + \theta) \frac{a}{2}$$

$$= (1-c)m\omega^2 r \times \frac{a}{2} (\cos \theta + \sin \theta)$$

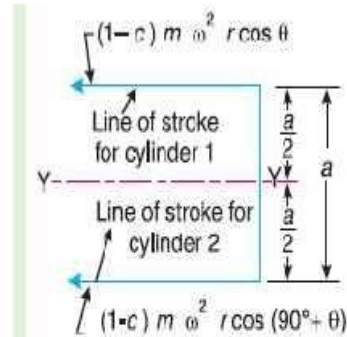

Fig. Swaying couple.

The swaying couple is maximum or minimum when  $(\cos \theta + \sin \theta)$  is maximum or minimum. For  $(\cos \theta + \sin \theta)$  to be maximum or minimum,

$$\frac{d}{d\theta} (\cos \theta + \sin \theta) = 0 \quad \text{or} \quad -\sin \theta + \cos \theta = 0 \quad \text{or} \quad -\sin \theta = -\cos \theta$$

$$\therefore \tan \theta = 1 \quad \text{or} \quad \theta = 45^\circ \quad \text{or} \quad 225^\circ$$

Thus, the swaying couple is maximum or minimum when  $\theta = 45^\circ$  or  $225^\circ$ .

∴ Maximum and minimum value of the swaying couple

$$= \pm (1-c)m\omega^2 r \times \frac{a}{2} (\cos 45^\circ + \sin 45^\circ) = \pm \frac{a}{\sqrt{2}} (1-c)m\omega^2 r$$

Hammer blow:

The maximum magnitude of the unbalanced force along the perpendicular to the line of stroke is known as Hammer blow.

We have already discussed that the maximum magnitude of the unbalanced force along the perpendicular to the line of stroke is known as *hammer blow*.

We know that the unbalanced force along the perpendicular to the line of stroke due to the balancing mass  $B$ , at a radius  $b$ , in order to balance reciprocating parts only is  $B \cdot \omega^2 \cdot b \sin \theta$ . This force will be maximum when  $\sin \theta$  is unity, i.e. when  $\theta = 90^\circ$  or  $270^\circ$ .

$$\therefore \text{Hammer blow} = B \cdot \omega^2 \cdot b \quad (\text{Substituting } \sin \theta = 1)$$

The effect of hammer blow is to cause the variation in pressure between the wheel and the rail. This variation is shown in Fig. 22.6, for one revolution of the wheel.

Let  $P$  be the downward pressure on the rails (or static wheel load).

## BALANCING OF INLINE ENGINES:

An in-line engine is one wherein all the cylinders are arranged in a single line, one behind the other as schematically indicated in Fig. Many of the passenger cars found on Indian roads such as Maruti 800, Zen, Santro, Honda City, Honda CR-V, and Toyota Corolla all have four cylinder in-line engines. Thus this is a commonly employed engine and it is of interest to us to understand the analysis of its state of balance.

∴ Net pressure between the wheel and the rail

$$= P \pm B \cdot \omega^2 \cdot b$$

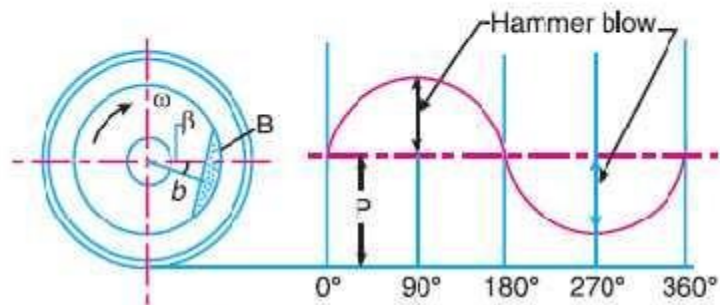

Fig. Hammer blow.

If  $(P - B \cdot \omega^2 \cdot b)$  is *negative*, then the wheel will be lifted from the rails. Therefore the limiting condition in order that the wheel does not lift from the rails is given by

$$P = B \cdot \omega^2 \cdot b$$

and the permissible value of the angular speed,

$$\omega = \sqrt{\frac{P}{B \cdot b}}$$

## BALANCING OF RADIAL ENGINES:

A radial engine is one in which all the cylinders are arranged circumferentially as shown in Fig. These engines were quite popularly used in aircrafts during World War II. Subsequent developments in steam/gas turbines led to the near extinction of these engines. However it is still interesting to study their state of balance in view of some elegant results we shall discuss shortly. Our method of analysis remains identical to the previous case i.e., we proceed with the assumption that all cylinders are identical and the cylinders are spaced at uniform interval around the circumference.

## **UNIT-V**

### **SINGLE DEGREE FREE VIBRATION**

#### **INTRODUCTION:**

When a system is subjected to an initial disturbance and then left free to vibrate on its own, the resulting vibrations are referred to as free vibrations. **Free vibration** occurs when a mechanical system is set off with an initial input and then allowed to vibrate freely. Examples of this type of vibration are pulling a child back on a swing and then letting go or hitting a tuning fork and letting it ring. The mechanical system will then vibrate at one or more of its "natural frequencies" and damp down to zero.

#### **CAUSES OF VIBRATION:**

**Misalignment:** This is another major cause of vibration particularly in machines that are driven by motors or any other prime movers.

**Bent Shaft:** A rotating shaft that is bent also produces the vibrating effect since it loses its rotation capability about its center.

**Gears in the machine:** The gears in the machine always tend to produce vibration, mainly due to their meshing. Though this may be controlled to some extent, any problem in the gearbox tends to get enhanced with ease.

**Bearings:** Last but not the least, here is a major contributor for vibration. In majority of the cases every initial problem starts in the bearings and propagates to the rest of the members of the machine. A bearing devoid of lubrication tends to wear out fast and fails quickly, but before this is noticed it damages the remaining components in the machine and an initial look would seem as if something had gone wrong with the other components leading to the bearing failure.

#### **Effects of vibration:**

##### **(a) Bad Effects:**

The presence of vibration in any mechanical system produces unwanted noise, high stresses, poor reliability, wear and premature failure of parts. Vibrations are a great source of human discomfort in the form of physical and mental strains.

### (b) Good Effects:

A vibration does useful work in musical instruments, vibrating screens, shakers, relieve pain in physiotherapy.

### METHODS OF REDUCTION OF VIBRATION:

- ◆ -unbalance is its main cause, so balancing of parts is necessary.
- ◆ -using shock absorbers.
- ◆ -using dynamic vibration absorbers.
- ◆ -providing the screens (if noise is to be reduced)

### TYPES OF VIBRATORY MOTION:

- ◆ Free Vibration
- ◆ Forced Vibration

### TERMS USED VIBRATORY MOTION:(a) Time period (or)period of vibration:

It is the time taken by a vibrating body to repeat the motion itself. Time period is usually expressed in seconds.

- a. Cycle: It is the motion completed in one time period.
- b. Periodic motion: A motion which repeats itself after equal interval of time.
- c. Amplitude (X): The maximum displacement of a vibrating body from the mean position.it is usually expressed in millimeter.
- d. Frequency (f): The number of cycles completed in one second is called frequency

### DEGREES OF FREEDOM:

The minimum number of independent coordinates required to specify the motion of a system at any instant is known as D.O.F of the system.

### Single degree of freedom system:

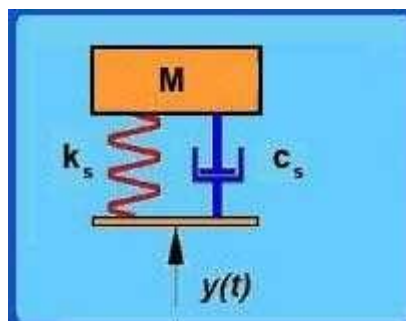

The system shown in this figure is what is known as a Single Degree of Freedom system. We use

the term degree of freedom to refer to the number of coordinates that are required to specify completely the configuration of the system. Here, if the position of the mass of the system is specified then accordingly the position of the spring and damper are also identified. Thus we need just one coordinate (that of the mass) to specify the system completely and hence it is known as a single degree of freedom system.

### Two degree of freedom system:

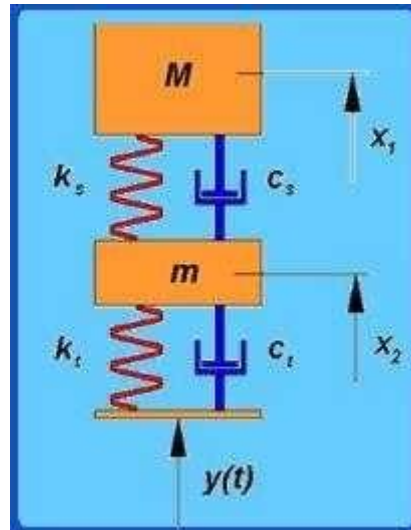

A two degree of freedom system With reference to automobile applications, this is referred as—quarter car model. The bottom mass refers to mass of axle, wheel etc components which are below the suspension spring and the top mass refers to the mass of the portion of the car and passenger. Since we need to specify both the top and bottom mass positions to completely specify the system, this becomes a two degree of freedom system.

### TYPES OF VIBRATORY MOTION:

#### Types of Vibration:

- (a) Longitudinal vibration
- (b) Transverse Vibration
- (c) Torsional Vibration.

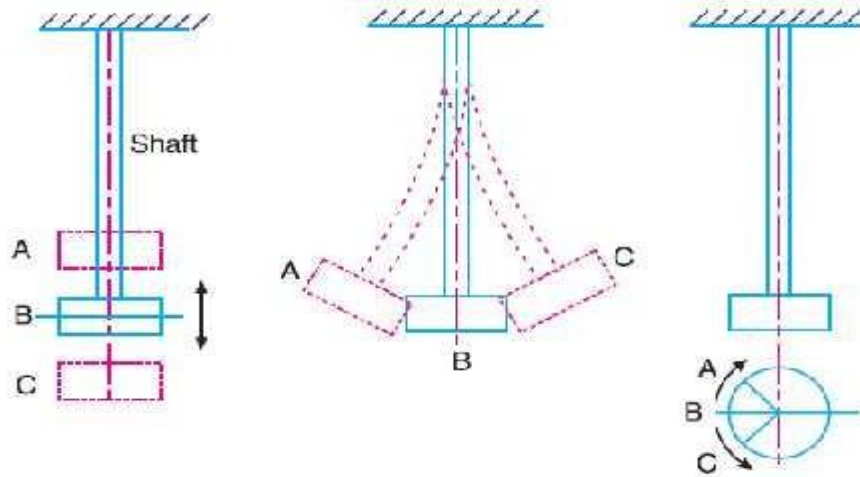

$B$  = Mean position ;  $A$  and  $C$  = Extreme positions.

(a) Longitudinal vibrations. (b) Transverse vibrations. (c) Torsional vibrations.

### Longitudinal Vibration:

When the particles of the shaft or disc moves parallel to the axis of the shaft, then the vibrations known as longitudinal vibrations.

### Free undamped longitudinal vibrations:

When a body is allowed to vibrate on its own, after giving it an initial displacement, then the ensuing vibrations are known as free or natural vibrations. When the vibrations take place parallel to the axis of constraint and no damping is provided, then it is called free undamped longitudinal vibrations.

### NATURAL FREQUENCY OF FREE UNDAMPED LONGITUDINAL VIBRATION:

$\delta$  - Static deflection of the spring in metres due to weight  $W$  newtons, and

$x$  - Displacement given to the body by the external force, in metres.

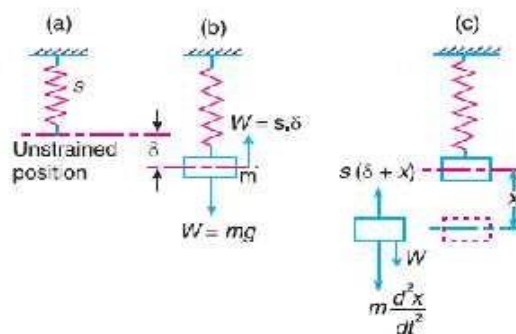

Natural frequency of free longitudinal vibrations.

In the equilibrium position, as shown in Fig. 23.2 (b), the gravitational pull  $W = mg$ , is balanced by a force of spring, such that  $W = s \delta$ .

Since the mass is now displaced from its equilibrium position by a distance  $x$ , as shown in Fig. (c), and is then released, therefore after time  $t$ ,

$$\begin{aligned} \text{Restoring force} &= W - s(\delta + x) = W - s\delta - s \cdot x \\ &= s\delta - s\delta - s \cdot x = -s \cdot x \quad \dots (\because W = s\delta) \quad \dots (i) \end{aligned}$$

and

Accelerating force = Mass  $\times$  Acceleration

$$= m \times \frac{d^2x}{dt^2} \dots \text{(Taking downward force as positive)} \dots \text{(ii)}$$

Equating equations (i) and (ii), the equation of motion of the body of mass  $m$  after time  $t$  is

$$m \times \frac{d^2x}{dt^2} = -s \cdot x \quad \text{or} \quad m \times \frac{d^2x}{dt^2} + s \cdot x = 0$$

$$\therefore \frac{d^2x}{dt^2} + \frac{s}{m} \times x = 0 \quad \dots \text{(iii)}$$

We know that the fundamental equation of simple harmonic motion is

$$\frac{d^2x}{dt^2} + \omega^2 \cdot x = 0 \quad \dots \text{(iv)}$$

Comparing equations (iii) and (iv), we have

$$\omega = \sqrt{\frac{s}{m}}$$

$$\therefore \text{Time period, } t_p = \frac{2\pi}{\omega} = 2\pi \sqrt{\frac{m}{s}}$$

and natural frequency,

$$f_n = \frac{1}{t_p} = \frac{1}{2\pi} \sqrt{\frac{s}{m}} = \frac{1}{2\pi} \sqrt{\frac{g}{\delta}} \quad \dots \text{(}\because m \cdot g = s \cdot \delta\text{)}$$

Taking the value of  $g$  as  $9.81 \text{ m/s}^2$  and  $\delta$  in metres,

$$f_n = \frac{1}{2\pi} \sqrt{\frac{9.81}{\delta}} = \frac{0.4985}{\sqrt{\delta}} \text{ Hz}$$

**Note :** The value of static deflection  $\delta$  may be found out from the given conditions of the problem. For longitudinal vibrations, it may be obtained by the relation,

$$\frac{\text{Stress}}{\text{Strain}} = E \quad \text{or} \quad \frac{W}{A} \times \frac{l}{\delta} = E \quad \text{or} \quad \delta = \frac{W \cdot l}{E \cdot A}$$

where

$\delta$  – Static deflection i.e. extension or compression of the constraint,

$W$  – Load attached to the free end of constraint,

$l$  – Length of the constraint,

$E$  – Young's modulus for the constraint, and

$A$  – Cross-sectional area of the constraint.

## Energy Method

In free vibrations, no energy is transferred into the system or from the system. Therefore, the

We know that the kinetic energy is due to the motion of the body and the potential energy is with respect to a certain datum position which is equal to the amount of work required to move the body from the datum position. In the case of vibrations, the datum position is the mean or equilibrium position at which the potential energy of the body or the system is zero.

In the free vibrations, no energy is transferred to the system or from the system. Therefore the summation of kinetic energy and potential energy must be a constant quantity which is same at all the times. In other words,

$$\therefore \frac{d}{dt}(K.E. + P.E.) = 0$$

We know that kinetic energy,

$$K.E. = \frac{1}{2} \times m \left( \frac{dx}{dt} \right)^2$$

and potential energy,

$$P.E. = \left( \frac{0 + s \cdot x}{2} \right) x = \frac{1}{2} \times s \cdot x^2$$

... ( $\because P.E. = \text{Mean force} \times \text{Displacement}$ )

$$\therefore \frac{d}{dt} \left[ \frac{1}{2} \times m \left( \frac{dx}{dt} \right)^2 + \frac{1}{2} \times s \cdot x^2 \right] = 0$$

$$\frac{1}{2} \times m \times 2 \times \frac{dx}{dt} \times \frac{d^2x}{dt^2} + \frac{1}{2} \times s \times 2x \times \frac{dx}{dt} = 0$$

$$\text{or } m \times \frac{d^2x}{dt^2} + s \cdot x = 0 \quad \text{or} \quad \frac{d^2x}{dt^2} + \frac{s}{m} \times x = 0 \quad \dots \text{ (Same as before)}$$

The time period and the natural frequency may be obtained as discussed in the previous method.

total energy (sum of KE and PE) is constant and is same all the times.

## Rayleigh's method

In this method, the maximum kinetic energy at mean position is made equal to the maximum potential energy at the extreme position.



This industrial compressor uses compressed air to power heavy-duty construction tools. Compressors are used for jobs, such as breaking up concrete or paving, drilling, pile driving, sand-blasting and tunnelling. A compressor works on the same principle as a pump. A piston moves backwards and forwards inside a hollow cylinder, which compresses the air and forces it into a hollow chamber. A pipe or hose connected to the chamber channels the compressed air to the tools.

Note : This picture is given as additional information and is not a direct example of the current chapter.



### EQUIVALENT STIFFNESS OF SPRING.

- (1) Springs in series
- (2) Springs in parallel
- (3) Combined springs
- (4) Inclined springs

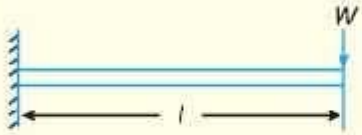
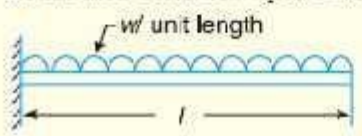
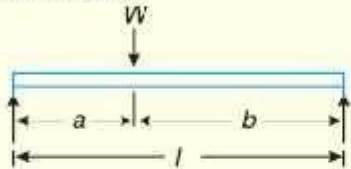
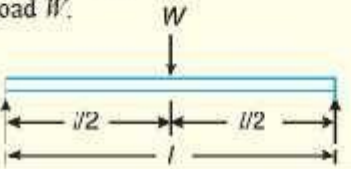
S.No.	Type of beam	Deflection ( $\delta$ )
1.	<p>Cantilever beam with a point load <math>W</math> at the free end.</p> 	$\delta = \frac{Wl^3}{3EI}$ (at the free end)
2.	<p>Cantilever beam with a uniformly distributed load of <math>w</math> per unit length.</p> 	$\delta = \frac{wl^4}{8EI}$ (at the free end)
3.	<p>Simply supported beam with an eccentric point load <math>W</math>.</p> 	$\delta = \frac{Wa^2b^2}{3EI}$ (at the point load)
4.	<p>Simply supported beam with a central point load <math>W</math>.</p> 	$\delta = \frac{Wl^3}{48EI}$ (at the centre)

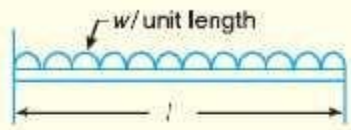
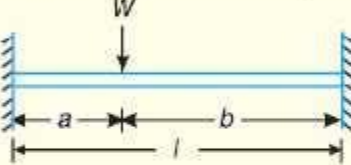
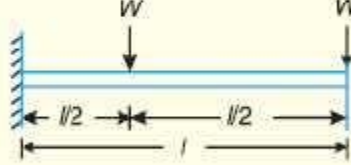
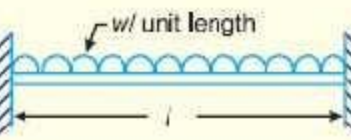
S.No.	Type of beam	Deflection ( $\delta$ )
5.	Simply supported beam with a uniformly distributed load of $w$ per unit length. 	$\delta = \frac{5}{384} \times \frac{wl^4}{EI}$ (at the centre)
6.	Fixed beam with an eccentric point load $W$ . 	$\delta = \frac{Wa^3b^3}{3EIl}$ (at the point load)
7.	Fixed beam with a central point load $W$ . 	$\delta = \frac{Wl^3}{192EI}$ (at the centre)
8.	Fixed beam with a uniformly distributed load of $w$ per unit length. 	$\delta = \frac{wl^4}{384EI}$ (at the centre)

### DAMPING:

It is the resistance to the motion of a vibrating body. The vibrations associated with this resistance are known as damped vibrations.

### Types of damping:

- (1) Viscous damping
- (2) Dry friction or coulomb damping
- (3) Solid damping or structural damping
- (4) Slip or interfacial damping.

The ratio of the actual damping coefficient ( $c$ ) to the critical damping coefficient ( $c_c$ ) is known as *damping factor or damping ratio*. Mathematically,

$$\text{Damping factor} = \frac{c}{c_c} = \frac{c}{2m\omega_n} \quad (\because c_c = 2m\omega_n)$$

The damping factor is the measure of the relative amount of damping in the existing system with that necessary for the critical damped system.

An example of such a system is a door damper – when we open a door and enter a room, we want the door to gradually close rather than exhibit oscillatory motion and bang into the person entering the room behind us! So the damper is designed such that

When  $\zeta < 1$ ,  $x(t)$  is a damped sinusoid and the system exhibits a vibratory motion whose amplitude keeps diminishing. This is the most common vibration case and we will spend most of our time studying such systems. These are referred to as **Underdamped system**

#### **Logarithmic decrement:**

It is defined as the natural logarithm of ratio of any two successive amplitudes of an under damped system. It is a dimensionless quantity.

## TRANSVERSE VIBRATION:

Consider a shaft of negligible mass, whose one end is fixed and the other end carries a body of weight  $W$ , as shown in Fig. 23.3.

Let  $s$  = Stiffness of shaft,  
 $\delta$  = Static deflection due to weight of the body,  
 $x$  = Displacement of body from mean position after time  $t$ .  
 $m$  = Mass of body =  $W/g$

As discussed in the previous article,

$$\text{Restoring force} = -s.x \quad \dots (i)$$

$$\text{and accelerating force} = m \times \frac{d^2x}{dt^2} \quad \dots (ii)$$

Equating equations (i) and (ii), the equation of motion becomes

$$m \times \frac{d^2x}{dt^2} = -s.x \quad \text{or} \quad m \times \frac{d^2x}{dt^2} + s.x = 0$$

$$\therefore \frac{d^2x}{dt^2} + \frac{s}{m} \times x = 0 \quad \dots \text{(Same as before)}$$

Hence, the time period and the natural frequency of the transverse vibrations are same as that of longitudinal vibrations. Therefore

$$\text{Time period, } t_p = 2\pi \sqrt{\frac{m}{s}}$$

$$\text{and natural frequency, } f_n = \frac{1}{t_p} = \frac{1}{2\pi} \sqrt{\frac{s}{m}} = \frac{1}{2\pi} \sqrt{\frac{g}{\delta}}$$

**Note :** The shape of the curve, into which the vibrating shaft deflects, is identical with the static deflection curve of a cantilever beam loaded at the end. It has been proved in the text book on Strength of Materials, that the static deflection of a cantilever beam loaded at the free end is

$$\delta = \frac{Wl^3}{3EI} \quad (\text{in metres})$$

where

$W$  = Load at the free end, in newtons,

$l$  = Length of the shaft or beam in metres,

$E$  = Young's modulus for the material of the shaft or beam in  $\text{N/m}^2$ , and

$I$  = Moment of inertia of the shaft or beam in  $\text{m}^4$ .

When the particles of the shaft or disc moves approximately perpendicular to the axis of the shaft, then the vibrations known as transverse vibrations.

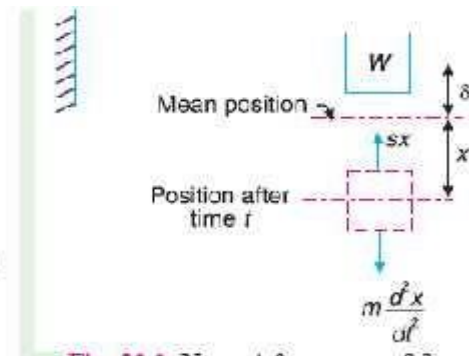

Fig. 23.3 Natural frequency of free transverse vibrations.

### Whirling speed of shaft:

The speed, at which the shaft runs so that the additional deflection of the shaft from the axis of rotation becomes infinite, is known as critical or whirling speed.

No shaft can ever be perfectly straight or perfectly balanced. When an element of mass is a distance from the axis of rotation, centrifugal force, will tend to pull the mass outward. The elastic properties of the shaft will act to restore the –straightness. If the frequency of rotation is equal to one of the resonant frequencies of the shaft, whirling will occur. In order to save the machine from failure, operation at such whirling speeds must be avoided.

When a shaft rotates, it may well go into transverse oscillations. If the shaft is out of balance, the resulting centrifugal force will induce the shaft to vibrate. When the shaft rotates at a speed equal to the natural frequency of transverse oscillations, this vibration becomes large and shows up as a whirling of the shaft. It also occurs at multiples of the resonant speed. This can be very damaging to heavy rotary machines such as turbine generator sets and the system must be carefully balanced to reduce this effect and designed to have a natural frequency different to the speed of rotation. When starting or stopping such machinery, the critical speeds must be avoided to prevent damage to the bearings and turbine blades. Consider a weightless shaft as shown with a mass  $M$  at the middle. Suppose the centre of the mass is not on the centre line.

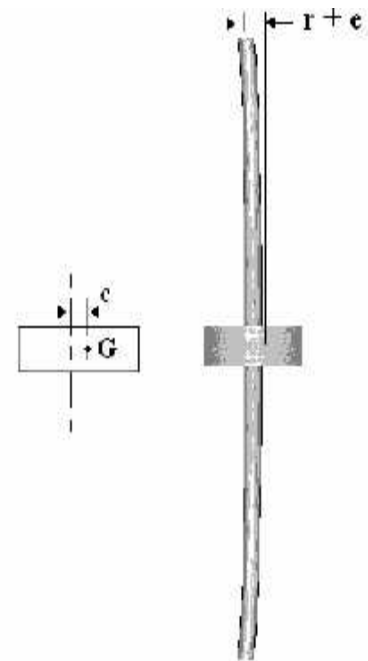

The whirling frequency of a symmetric cross section of a given length between two points is given by:

$$N = 94.25 \sqrt{\frac{E I}{m L^3}} \text{ RPM}$$

Where  $E$  = young's modulus,  $I$  = Second moment of area,  $m$  = mass of the shaft,  $L$  = length of the shaft between points

A shaft with weights added will have an angular velocity of  $N$  (rpm) equivalent as follows:

$$\frac{1}{N_N^2} = \frac{1}{N_A^2} + \frac{1}{N_B^2} + \dots + \frac{1}{N_n^2}$$

### TORSIONAL VIBRATION:

When the particles of the shaft or disc move in a circle about the axis of the shaft, then the vibrations known as torsional vibration

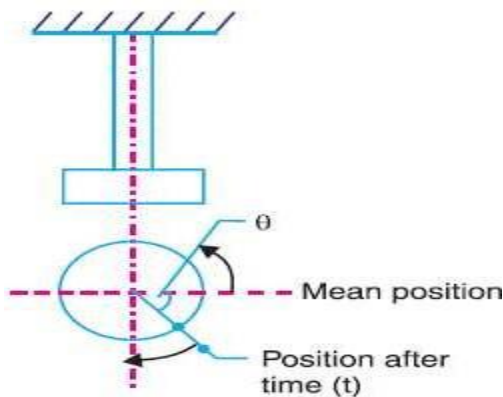

Let  $\theta$  = Angular displacement of the shaft from mean position after time  $t$  in radians,  
 $m$  = Mass of disc in kg,  
 $I$  = Mass moment of inertia of disc in  $\text{kg}\cdot\text{m}^2 = m.k^2$ ,  
 $k$  = Radius of gyration in metres,  
 $q$  = Torsional stiffness of the shaft in N-m.

Natural frequency of free torsional vibrations.

$$\therefore \text{Restoring force} = q.\theta \quad \dots (i)$$

$$\text{and accelerating force} = I \times \frac{d^2\theta}{dt^2} \quad \dots (ii)$$

Equating equations (i) and (ii), the equation of motion is

$$I \times \frac{d^2\theta}{dt^2} = -q.\theta$$

$$\text{or} \quad I \times \frac{d^2\theta}{dt^2} + q.\theta = 0$$

$$\therefore \frac{d^2\theta}{dt^2} + \frac{q}{I} \times \theta = 0 \quad \dots (iii)$$

The fundamental equation of the simple harmonic motion is

$$\frac{d^2x}{dt^2} + \omega^2 x = 0 \quad \dots (iv)$$

Comparing equations (iii) and (iv),

$$\omega = \sqrt{\frac{q}{I}}$$

$$\therefore \text{Time period, } t_p = \frac{2\pi}{\omega} = 2\pi \sqrt{\frac{I}{q}}$$

$$\text{and natural frequency, } f_n = \frac{1}{t_p} = \frac{1}{2\pi} \sqrt{\frac{q}{I}}$$

The value of the torsional stiffness  $q$  may be obtained from the torsion equation,

$$\frac{T}{J} = \frac{C\theta}{l} \quad \text{or} \quad \frac{T}{\theta} = \frac{CJ}{l}$$

$$q = \frac{CJ}{l} \quad \dots \left( \because \frac{T}{\theta} = q \right)$$

where  $C$  = Modulus of rigidity for the shaft material,  
 $J$  = Polar moment of inertia of the shaft cross-section,

$$= \frac{\pi}{32} d^4 \quad ; \quad d \text{ is the diameter of the shaft, and}$$

$l$  = Length of the shaft.

### Torsional vibration of a single rotor system:

We have already discussed that for a shaft fixed at one end and carrying a rotor at the free end as shown in Fig. the natural frequency of torsional vibration,

$$f_n = \frac{1}{2} \sqrt{\frac{q}{I}} = \frac{1}{2} \sqrt{\frac{CJ}{lI}}$$

$$\dots \quad q = \frac{CJ}{l}$$

where  $C$  = Modulus of rigidity for shaft material,  
 $J$  = Polar moment of inertia of shaft

$$= \frac{\pi}{32} d^4$$

$d$  = Diameter of shaft,

$l$  = Length of shaft,

$m$  = Mass of rotor,

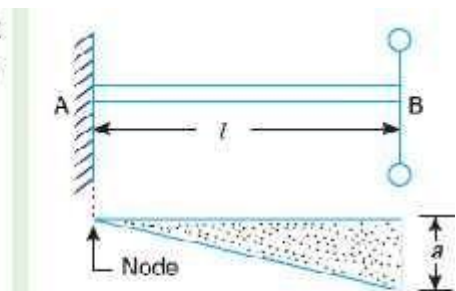

Free torsional vibrations of a single rotor system.

$k$  = Radius of gyration of rotor, and

$$I = \text{Mass moment of inertia of rotor} = m.k^2$$

A little consideration will show that the amplitude of vibration is zero at  $A$  and maximum at  $B$ , as shown in Fig. It may be noted that the point or the section of the shaft whose amplitude of torsional vibration is zero, is known as **node**. In other words, at the node, the shaft remains unaffected by the vibration.

## Torsional vibration of a two rotor system:

Consider a two rotor system as shown in Fig. It consists of a shaft with two rotors at its ends. In this system, the torsional vibrations occur only when the two rotors  $A$  and  $B$  move in opposite directions *i.e.* if  $A$  moves in anticlockwise direction then  $B$  moves in clockwise direction at the same instant and *vice versa*. It may be noted that the two rotors must have the same frequency.

We see from Fig. that the node lies at point  $N$ . This point can be safely assumed as a fixed end and the shaft may be considered as two separate shafts  $NP$  and  $NQ$  each fixed to one of its ends and carrying rotors at the free ends.

- Let
- $l$  = Length of shaft,
  - $l_A$  = Length of part  $NP$  *i.e.* distance of node from rotor  $A$ ,
  - $l_B$  = Length of part  $NQ$ , *i.e.* distance of node from rotor  $B$ ,
  - $I_A$  = Mass moment of inertia of rotor  $A$ ,
  - $I_B$  = Mass moment of inertia of rotor  $B$ ,
  - $d$  = Diameter of shaft,
  - $J$  = Polar moment of inertia of shaft, and
  - $C$  = Modulus of rigidity for shaft material.

Natural frequency of torsional vibration for rotor  $A$ ,

$$f_{nA} = \frac{1}{2} \sqrt{\frac{CJ}{l_A I_A}} \quad \dots (i)$$

and natural frequency of torsional vibration for rotor  $B$ ,

$$f_{nB} = \frac{1}{2} \sqrt{\frac{CJ}{l_B I_B}} \quad \dots (ii)$$

Since  $f_{nA} = f_{nB}$ , therefore

$$\frac{1}{2} \sqrt{\frac{CJ}{l_A I_A}} = \frac{1}{2} \sqrt{\frac{CJ}{l_B I_B}} \quad \text{or} \quad l_A \cdot I_A = l_B \cdot I_B \quad \dots (iii)$$

$$l_A = \frac{l_B \cdot I_B}{I_A}$$

We also know that

$$l = l_A + l_B \quad \dots (iv)$$

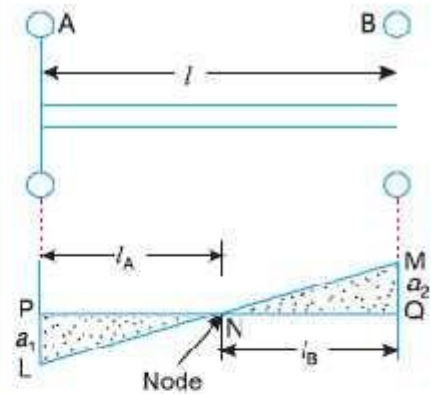

Fig. Free torsional vibrations of a two rotor system.



**Torsionally equivalent shaft:**

we have assumed that the shaft is of uniform diameter. But in actual practice, the shaft may have variable diameter for different lengths. Such a shaft may, theoretically, be replaced by an equivalent shaft of uniform diameter.

Consider a shaft of varying diameters as shown in Fig. (a). Let this shaft is replaced by an equivalent shaft of uniform diameter  $d$  and length  $l$  as shown in Fig. (b). These two shafts must have the same total angle of twist when equal opposing torques  $T$  are applied at their opposite ends.

- Let
- $d_1, d_2$  and  $d_3$  = Diameters for the lengths  $l_1, l_2$  and  $l_3$  respectively,
  - $\theta_1, \theta_2$  and  $\theta_3$  = Angle of twist for the lengths  $l_1, l_2$  and  $l_3$  respectively,
  - $\theta$  = Total angle of twist, and
  - $J_1, J_2$  and  $J_3$  = Polar moment of inertia for the shafts of diameters  $d_1, d_2$  and  $d_3$  respectively.

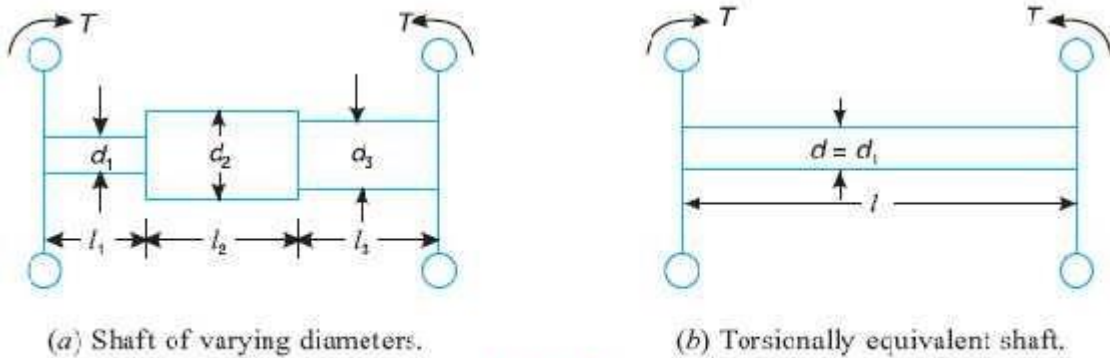

**Fig 24.8**

Since the total angle of twist of the shaft is equal to the sum of the angle of twists of different lengths, therefore

$$\text{or } \frac{Tl}{CJ} = \frac{Tl_1}{CJ_1} + \frac{Tl_2}{CJ_2} + \frac{Tl_3}{CJ_3}$$

$$\frac{l}{J} = \frac{l_1}{J_1} + \frac{l_2}{J_2} + \frac{l_3}{J_3}$$

$$\frac{l}{32 d^4} = \frac{l_1}{32 (d_1)^4} + \frac{l_2}{32 (d_2)^4} + \frac{l_3}{32 (d_3)^4}$$

$$\frac{l}{d^4} = \frac{l_1}{(d_1)^4} + \frac{l_2}{(d_2)^4} + \frac{l_3}{(d_3)^4}$$

In actual calculations, it is assumed that the diameter  $d$  of the equivalent shaft is equal to one of the diameter of the actual shaft. Let us assume that  $d = d_1$ .

$$\frac{l}{(d_1)^4} = \frac{l_1}{(d_1)^4} + \frac{l_2}{(d_2)^4} + \frac{l_3}{(d_3)^4}$$

or 
$$l = l_1 + l_2 \frac{d_1^4}{d_2^4} + l_3 \frac{d_1^4}{d_3^4}$$

This expression gives the length  $l$  of an equivalent shaft.

## SOLVED ROBLEMS

1. A machine of mass 75 kg is mounted on springs and is fitted with a dashpot to damp out vibrations.

There are three springs each of stiffness 10 N/mm and it is found that the amplitude of vibration diminishes from 38.4 mm to 6.4 mm in two complete oscillations. Assuming that the damping force varies as the velocity, determine : 1. the resistance of the dash-pot at unit velocity ; 2. the ratio of the frequency of the damped vibration to the frequency of the undamped vibration ; and 3. the periodic time of the damped vibration.

**Solution.** Given :  $m = 75 \text{ kg}$  ;  $s = 10 \text{ N/mm} = 10 \times 10^3 \text{ N/m}$  ;  $x_1 = 38.4 \text{ mm} = 0.0384 \text{ m}$

;  $x_3 = 6.4 \text{ mm} = 0.0064 \text{ m}$

Since the stiffness of each spring is  $10 \times 10^3 \text{ N/m}$  and there are 3 springs, therefore

total stiffness,

$$s = 3 \times 10 \times 10^3 = 30 \times 10^3 \text{ N/m}$$

We know that natural circular frequency of motion,

$$\omega_n = \sqrt{\frac{s}{m}} = \sqrt{\frac{30 \times 10^3}{75}} = 20 \text{ rad/s}$$

Let  $c$  = Resistance of the dashpot in newtons at unit velocity i.e. in N/m/s,

$x_2$  = Amplitude after one complete oscillation in metres, and

$x_3$  = Amplitude after two complete oscillations in metres.

We know that  $\frac{x_1}{x_2} = \frac{x_2}{x_3}$

### 1. Resistance of the dashpot at unit velocity

$$\therefore \left( \frac{x_1}{x_2} \right)^2 = \frac{x_1}{x_3} \quad \dots \left[ \because \frac{x_1}{x_3} = \frac{x_1}{x_2} \times \frac{x_2}{x_3} = \frac{x_1}{x_2} \times \frac{x_2}{x_2} = \left( \frac{x_1}{x_2} \right)^2 \right]$$

or  $\frac{x_1}{x_2} = \left( \frac{x_1}{x_3} \right)^{1/2} = \left( \frac{0.0384}{0.0054} \right)^{1/2} = 2.45$

We also know that

$$\log_e \left( \frac{x_1}{x_2} \right) = a \times \frac{2\pi}{\sqrt{(\omega_n)^2 - a^2}}$$

### 2.2. Ratio of the frequency of the damped vibration to the frequency of undamped vibration

Let  $f_{d1} =$  Frequency of damped vibration  $= \frac{\omega_d}{2\pi}$

$f_{u2} =$  Frequency of undamped vibration  $= \frac{\omega_n}{2\pi}$

$\therefore \frac{f_{d1}}{f_{u2}} = \frac{\omega_d}{2\pi} \times \frac{2\pi}{\omega_n} = \frac{\omega_d}{\omega_n} = \frac{\sqrt{(\omega_n)^2 - a^2}}{\omega_n} = \frac{\sqrt{(20)^2 - (2.8)^2}}{20} = 0.99$  Ans.

### 3. Periodic time of damped vibration

We know that periodic time of damped vibration

$$= \frac{2\pi}{\omega_d} = \frac{2\pi}{\sqrt{(\omega_n)^2 - a^2}} = \frac{2\pi}{\sqrt{(20)^2 - (2.8)^2}} = 0.32 \text{ s Ans.}$$

2. The mass of a single degree damped vibrating system is 7.5 kg and makes 24 free oscillations in 14

seconds when disturbed from its equilibrium position. The amplitude of vibration reduces to 0.25 of its initial value after five oscillations. Determine : 1. stiffness of the spring, 2. logarithmic decrement, and 3. damping factor, i.e. the ratio of the system damping to critical damping.

**Solution.** Given :  $m = 7.5 \text{ kg}$

$$f_n = 24/14 = 1.7$$

and

$$\omega_n = 2\pi \times f_n = 2\pi \times 1.7 = 10.7 \text{ rad/s}$$

### 1. Stiffness of the spring

Let  $s$  - Stiffness of the spring in N/m.

We know that  $(\omega_n)^2 = s/m$  or  $s = (\omega_n)^2 m = (10.7)^2 \times 7.5 = 860 \text{ N/m}$  **Ans.**

Since 24 oscillations are made in 14 seconds, therefore frequency of free vibrations,

$$\log_e 2.45 = n \times \frac{2\pi}{\sqrt{(20)^2 - a^2}}$$

$$0.8951 = \frac{a \times 2\pi}{\sqrt{400 - a^2}} \quad \text{or} \quad 0.8 = \frac{a^2 \times 39.5}{400 - a^2} \quad \dots \text{ (Squaring both sides)}$$

$$\therefore a^2 = 7.94 \quad \text{or} \quad a = 2.8$$

We know that  $a = c / 2m$

$$\therefore c = a \times 2m = 2.8 \times 2 \times 7.5 = 420 \text{ N/m/s}$$
 **Ans.**

### 3. Damping factor

Let  $c$  = Damping coefficient for the actual system, and

$c_c$  = Damping coefficient for the critical damped system. ... (Given)

We know that logarithmic decrement ( $\delta$ ),

$$0.28 = \frac{a \times 2\pi}{\sqrt{(\omega_n)^2 - a^2}} = \frac{a \times 2\pi}{\sqrt{(10.7)^2 - a^2}} \quad \left[ \frac{x_4}{x_5} - \frac{x_5}{x_6} \right]$$

or

$$\frac{x_1}{x_2} = \left( \frac{x_1}{x_5} \right)^{1/5} = \left( \frac{x_1}{0.25 x_1} \right)^{1/5} = (4)^{1/5} = 1.32$$

We know that logarithmic decrement,

$$\delta = \log_e \left( \frac{x_1}{x_2} \right) = \log_e 1.32 = 0.28$$
 **Ans.**

$$0.0784 = \frac{a^2 \times 39.5}{114.5 - a^2} \quad \dots \text{(Squaring both sides)}$$

$$8.977 \quad 0.0784 a^2 = 39.5 a^2 \quad \text{or} \quad a^2 = 0.227 \quad \text{or} \quad a = 0.476$$

We know that  $a = c / 2m$  or  $c = a \times 2m = 0.476 \times 2 \times 7.5 = 7.2 \text{ N/m/s}$  **Ans.**

and

$$c_c = 2m\omega_n = 2 \times 7.5 \times 10.7 = 160.5 \text{ N/m/s} \text{ **Ans.**}$$

∴

$$\text{Damping factor} = c/c_c = 7.2 / 160.5 = 0.045 \text{ **Ans.**}$$

3(i) The measurements on a mechanical vibrating system show that it has a mass of 8 kg and that the springs can be combined to give an equivalent spring of stiffness 5.4 N/mm. If the vibrating system have a dashpot attached which exerts a force of 40 N when the mass has a velocity of 1 m/s, find : 1. critical damping coefficient, 2. damping factor, 3. logarithmic decrement, and 4. ratio of two consecutive amplitudes.

**Solution.** Given :  $m = 8 \text{ kg}$  ;  $s = 5.4 \text{ N/mm} = 5400 \text{ N/m}$

Since the force exerted by dashpot is 40 N, and the mass has a velocity of 1 m/s , therefore Damping

### 1. Critical damping coefficient

We know that critical damping coefficient,

$$c_c = 2m\omega_n = 2m \times \sqrt{\frac{s}{m}} = 2 \times 8 \times \sqrt{\frac{5400}{8}} = 416 \text{ N/m/s} \text{ **Ans.**}$$

coefficient (actual),

### 3. Logarithmic decrement

We know that logarithmic decrement,

$$\delta = \frac{2\pi c}{\sqrt{(c_c)^2 - c^2}} = \frac{2\pi \times 40}{\sqrt{(416)^2 - (40)^2}} = 0.6 \text{ **Ans.**}$$

### 4. Ratio of two consecutive amplitudes

Let  $x_n$  and  $x_{n-1}$  = Magnitude of two consecutive amplitudes,

We know that logarithmic decrement,

$$\delta = \log_e \left[ \frac{x_n}{x_{n+1}} \right] \quad \text{or} \quad \frac{x_n}{x_{n+1}} = e^\delta = (2.7)^{0.6} = 1.82 \text{ **Ans.**}$$

### 2. Damping factor

We know that damping factor

$$\frac{c}{c_c} = \frac{40}{416} = 0.096 \text{ **Ans.**}$$

$c = 40 \text{ N/m/s}$

3 (ii) An instrument vibrates with a frequency of 1 Hz when there is no damping. When the damping is provided, the frequency of damped vibrations was observed to be 0.9 Hz. Find 1. the damping factor, and 2. logarithmic decrement.

**Solution.** Given :  $f_n = 1 \text{ Hz}$  ;  $f_d = 0.9 \text{ Hz}$

**1. Damping factor**

Let  $m =$  Mass of the instrument in kg,

$c =$  Damping coefficient

or damping force per unit velocity in N/m/s, and

$c_c =$  Critical damping coefficient in N/m/s.

$$\omega_n = 2\pi \times f_n = 2\pi \times 1 = 6.284 \text{ rad/s}$$

and circular frequency of damped vibrations,

$$\omega_d = 2\pi \times f_d = 2\pi \times 0.9 = 5.66 \text{ rad/s}$$

We also know that circular frequency of damped vibrations ( $\omega_d$ ),

$$5.66 = \sqrt{(\omega_n)^2 - a^2} = \sqrt{(6.284)^2 - a^2}$$

We know that natural circular frequency of undamped vibrations,

Squaring both sides,

$$(5.66)^2 = (6.284)^2 - a^2 \text{ or } 32 = 39.5 - a^2$$

$$\therefore a^2 = 7.5 \quad \text{or} \quad a = 2.74$$

$$\text{We know that, } a = c/2m \quad \text{or} \quad c = a \times 2m = 2.74 \times 2m = 5.48 \text{ m N/m/s}$$

$$\text{and } c_c = 2m\omega_n = 2m \times 6.284 = 12.568 \text{ m N/m/s}$$

$\therefore$  Damping factor,

$$c/c_c = 5.48m/12.568m = 0.436 \text{ Ans.}$$

4(i) A coil of spring stiffness 4 N/mm supports vertically a mass of 20 kg at the free end. The motion is resisted by the oil dashpot. It is found that the amplitude at the beginning of the fourth cycle is 0.8 times the amplitude of the previous vibration. Determine the damping force per unit velocity. Also find the ratio of the frequency of damped and undamped vibrations.

**Solution.** Given :  $s = 4 \text{ N/mm} = 4000 \text{ N/m}$  ;  $m = 20 \text{ kg}$

**Damping force per unit velocity**

Let  $c =$  Damping force in newtons per unit velocity i.e. in N/m/s

$x_n$  = Amplitude at the beginning of the third cycle,

$x_{n+1}$  = Amplitude at the beginning of the fourth cycle =  $0.8 x_n$

$$\omega_n = \sqrt{\frac{s}{m}} = \sqrt{\frac{4000}{20}} = 14.14 \text{ rad/s}$$

and  $\log_e \left( \frac{x_n}{x_{n+1}} \right) = a \times \frac{2\pi}{\sqrt{(\omega_n)^2 - a^2}}$

or  $\log_e \left( \frac{x_n}{0.8 x_n} \right) = a \times \frac{2\pi}{\sqrt{(14.14)^2 - a^2}}$

$$\log_e 1.25 = a \times \frac{2\pi}{\sqrt{200 - a^2}} \quad \text{or} \quad 0.223 = a \times \frac{2\pi}{\sqrt{200 - a^2}}$$

Squaring both sides

$$0.05 = \frac{a^2 \times 4\pi^2}{200 - a^2} = \frac{39.5 a^2}{200 - a^2}$$

$$0.05 \times 200 - 0.05 a^2 = 39.5 a^2 \quad \text{or} \quad 39.55 a^2 = 10$$

$$\therefore a^2 = 10 / 39.55 = 0.25 \quad \text{or} \quad a = 0.5$$

We know that  $a = c / 2m$

$$\therefore c = a \times 2m = 0.5 \times 2 \times 20 = 20 \text{ N/m/s} \text{ Ans.}$$

We know that natural circular frequency of motion,

### Ratio of the frequencies

Let  $f_{n1}$  = Frequency of damped vibrations =  $\frac{\omega_d}{2\pi}$

$f_{n2}$  = Frequency of undamped vibrations =  $\frac{\omega_n}{2\pi}$

$\therefore$

$$\begin{aligned} \frac{f_{n1}}{f_{n2}} &= \frac{\omega_d}{2\pi} \times \frac{2\pi}{\omega_n} = \frac{\omega_d}{\omega_n} = \sqrt{\frac{(\omega_n)^2 - a^2}{\omega_n^2}} = \sqrt{\frac{(14.14)^2 - (0.5)^2}{14.14^2}} \\ &= 0.999 \text{ Ans.} \end{aligned}$$

$\dots (\because \omega_d = \sqrt{(\omega_n)^2 - a^2})$

#### 4(ii) Derive an expression for the natural frequency of single degrees of freedom system.

We know that the kinetic energy is due to the motion of the body and the potential energy is with respect to a certain datum position which is equal to the amount of work required to move the body from the datum position. In the case of vibrations, the datum position is the mean or equilibrium position at which the potential energy of the body or the system is zero. In the free vibrations, no

energy is transferred to the system or from the system. Therefore the summation of kinetic energy and potential energy must be a constant quantity which is same at all the times. In other words,

We know that  $\therefore \frac{d}{dt} (K.E. + P.E.) = 0$  kinetic energy,

$$K.E. = \frac{1}{2} \times m \left( \frac{dx}{dt} \right)^2$$

and potential energy,

$$P.E. = \left( \frac{0 + s \cdot x}{2} \right) \times \frac{1}{2} \times s \cdot x^2$$

... ( $\because$  P.E. = Mean force  $\times$  Displacement)

$$\therefore \frac{d}{dt} \left[ \frac{1}{2} \times m \left( \frac{dx}{dt} \right)^2 + \frac{1}{2} \times s \cdot x^2 \right] = 0$$

$$\frac{1}{2} \times m \times 2 \times \frac{dx}{dt} \times \frac{d^2x}{dt^2} + \frac{1}{2} \times s \times 2x \times \frac{dx}{dt} = 0$$

$$\text{or } m \times \frac{d^2x}{dt^2} + s \cdot x = 0 \quad \text{or } \frac{d^2x}{dt^2} + \frac{s}{m} \times x = 0$$

We know that the fundamental equation of simple harmonic motion is

$$\frac{d^2x}{dt^2} + \omega^2 \cdot x = 0$$

Comparing equations,

$$\omega = \sqrt{\frac{s}{m}}$$

$$\therefore \text{Time period, } t_p = \frac{2\pi}{\omega} = 2\pi \sqrt{\frac{m}{s}}$$

$$\text{and natural frequency, } f_n = \frac{1}{t_p} = \frac{1}{2\pi} \sqrt{\frac{s}{m}} = \frac{1}{2\pi} \sqrt{\frac{g}{\delta}} \quad \dots (\because m \cdot g = s \cdot \delta)$$

Taking the value of  $g$  as  $9.81 \text{ m/s}^2$  and  $\delta$  in metres,

$$f_n = \frac{1}{2\pi} \sqrt{\frac{9.81}{\delta}} = \frac{0.4985}{\sqrt{\delta}} \text{ Hz}$$



## **FORCED VIBRATION**

When a system is subjected continuously to time varying disturbances, the vibrations resulting under the presence of the external disturbance are referred to as forced vibrations.

**Forced vibration** is when an alternating force or motion is applied to a mechanical system. Examples of this type of vibration include a shaking washing machine due to an imbalance, transportation vibration (caused by truck engine, springs, road, etc), or the vibration of a building during an earthquake. In forced vibration the frequency of the vibration is the frequency of the force or motion applied, with order of magnitude being dependent on the actual mechanical system.

When a vehicle moves on a rough road, it is continuously subjected to road undulations causing the system to vibrate (pitch, bounce, roll etc). Thus the automobile is said to undergo forced vibrations. Similarly whenever the engine is turned on, there is a resultant residual unbalance force that is transmitted to the chassis of the vehicle through the engine mounts, causing again forced vibrations of the vehicle on its chassis. A building when subjected to time varying ground motion (earthquake) or wind loads, undergoes forced vibrations. Thus most of the practical examples of vibrations are indeed forced vibrations.

### **CAUSES OF RESONANCE:**

Resonance is simple to understand if you view the spring and mass as energy storage elements – with the mass storing kinetic energy and the spring storing potential energy. As discussed earlier, when the mass and spring have no force acting on them they transfer energy back and forth at a rate equal to the natural frequency. In other words, if energy is to be efficiently pumped into both the mass and spring the energy source needs to feed the energy in at a rate equal to the natural frequency. Applying a force to the mass and spring is similar to pushing a child on swing, you need to push at the correct moment if you want the swing to get higher and higher. As in the case of the swing, the force applied does not necessarily have to be high to get large motions; the pushes just need to keep adding energy into the system.

The damper, instead of storing energy, dissipates energy. Since the damping force is proportional to the velocity, the more the motion, the more the damper dissipates the energy. Therefore a point will come when the energy dissipated by the damper will equal the energy being fed in by the force. At this point, the system has reached its maximum amplitude and will continue to

vibrate at this level as long as the force applied stays the same. If no damping exists, there is nothing to dissipate the energy and therefore theoretically the motion will continue to grow on into infinity.

### **FORCED VIBRATION OF A SINGLE DEGREE-OF-FREEDOM SYSTEM:**

We saw that when a system is given an initial input of energy, either in the form of an initial displacement or an initial velocity, and then released it will, under the right conditions, vibrate freely. If there is damping in the system, then the oscillations die away. If a system is given a continuous input of energy in the form of a continuously applied force or a continuously applied displacement, then the consequent vibration is called forced vibration. The energy input can overcome that dissipated by damping mechanisms and the oscillations are sustained.

We will consider two types of forced vibration. The first is where the ground to which the system is attached is itself undergoing a periodic displacement, such as the vibration of a building in an earthquake. The second is where a periodic force is applied to the mass, or object performing the motion; an example might be the forces exerted on the body of a car by the forces produced in the engine. The simplest form of periodic force or displacement is sinusoidal, so we will begin by considering forced vibration due to sinusoidal motion of the ground. In all real systems, energy will be dissipated, i.e. the system will be damped, but often the damping is very small. So let us first analyze systems in which there is no damping.

### **STEADY STATE RESPONSE DUE TO HARMONIC OSCILLATION:**

Consider a spring-mass-damper system as shown in figure 4.1. The equation of motion of this system subjected to a harmonic force  $F \sin \omega t$  can be given by

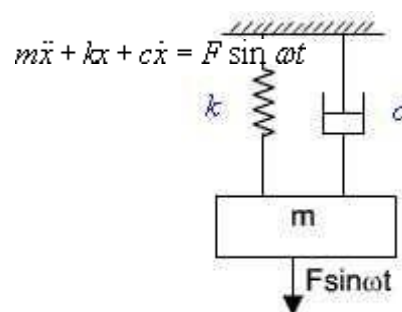

where,  $m$ ,  $k$  and  $c$  are the mass, spring stiffness and damping coefficient of the system,  $F$  is the amplitude of the force,  $w$  is the excitation frequency or driving frequency.

Figure : Harmonically excited system

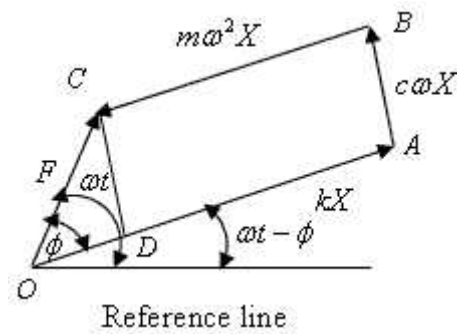

Figure : Force polygon

The steady state response of the system can be determined by solving equation(4.1) in many different ways. Here a simpler graphical method is used which will give physical understanding to this dynamic problem. From solution of differential equations it is known that the steady state solution (particular integral) will be of the form

#### FORCED VIBRATION WITH DAMPING:

In this section we will see the behaviour of the spring mass damper model when we add a harmonic force in the form below. A force of this type could, for example, be generated by a rotating

$$F = F_0 \cos(2\pi ft).$$

imbalance.

If we again sum the forces on the mass we get the following ordinary differential equation:

$$m\ddot{x} + c\dot{x} + kx = F_0 \cos(2\pi ft).$$

The steady state solution of this problem can be written as:

$$x(t) = X \cos(2\pi ft - \phi).$$

The result states that the mass will oscillate at the same frequency,  $f$ , of the applied force, but with a phase shift  $\phi$ .

$$X = \frac{F_0}{k} \frac{1}{\sqrt{(1-r^2)^2 + (2\zeta r)^2}}$$

The amplitude of the vibration  $-X|$  is defined by the following formula.

Where  $r$  is defined as the ratio of the harmonic force frequency over the undamped

$$r = \frac{f}{f_n}$$

natural frequency of the mass–spring–damper model.

The phase shift ,  $\phi$ , is defined by the following formula.

$$\phi = \arctan\left(\frac{2\zeta r}{1-r^2}\right).$$

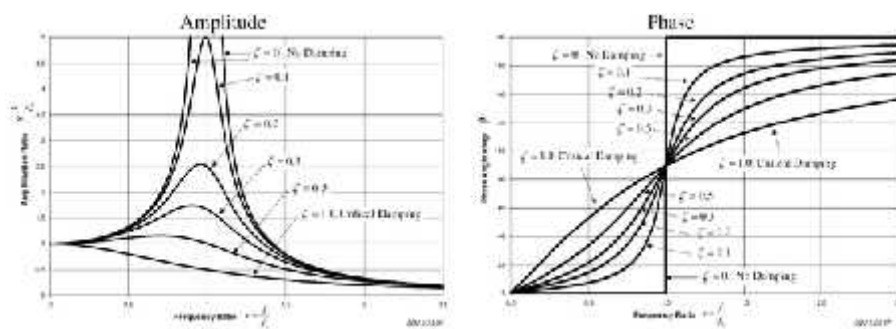

The plot of these functions, called "the frequency response of the system", presents one of the most important features in forced vibration. In a lightly damped system when the forcing frequency nears the natural frequency ( $r \approx 1$ ) the amplitude of the vibration can get extremely high. This phenomenon is called **resonance** (subsequently the natural frequency of a system is often referred to as the resonant frequency). In rotor bearing systems any rotational speed that excites a resonant frequency is referred to as a critical speed.

If resonance occurs in a mechanical system it can be very harmful – leading to eventual failure of the system. Consequently, one of the major reasons for vibration analysis is to predict when this type of resonance may occur and then to determine what steps to take to prevent it from occurring. As the amplitude plot shows, adding damping can significantly reduce the magnitude of the

vibration. Also, the magnitude can be reduced if the natural frequency can be shifted away from the forcing frequency by changing the stiffness or mass of the system. If the system cannot be changed, perhaps the forcing frequency can be shifted (for example, changing the speed of the machine generating the force).

The following are some other points in regards to the forced vibration shown in the frequency response plots.

At a given frequency ratio, the amplitude of the vibration,  $X$ , is directly proportional to the amplitude of the force  $F_0$  (e.g. if you double the force, the vibration doubles)

With little or no damping, the vibration is in phase with the forcing frequency when the frequency ratio  $r < 1$  and 180 degrees out of phase when the frequency ratio  $r > 1$

When  $r \ll 1$  the amplitude is just the deflection of the spring under the static force  $F_0$ . This deflection is called the static deflection  $\delta_{st}$ . Hence, when  $r \ll 1$  the effects of the damper and the mass are minimal.

When  $r \gg 1$  the amplitude of the vibration is actually less than the static deflection  $\delta_{st}$ . In this region the force generated by the mass ( $F = ma$ ) is dominating because the acceleration seen by the mass increases with the frequency. Since the deflection seen in the spring,  $X$ , is reduced in this region, the force transmitted by the spring ( $F = kx$ ) to the base is reduced. Therefore the mass–spring–damper system is isolating the harmonic force from the mounting base – referred to as vibration isolation. Interestingly, more damping actually reduces the effects of vibration isolation when  $r \gg 1$  because the damping force ( $F = cv$ ) is also transmitted to the base.

### **ROTATING UNBALANCE FORCED VIBRATION:**

One may find many rotating systems in industrial applications. The unbalanced force in such a system can be represented by a mass  $m$  with eccentricity  $e$ , which is rotating with angular velocity as shown in Figure 4.1.

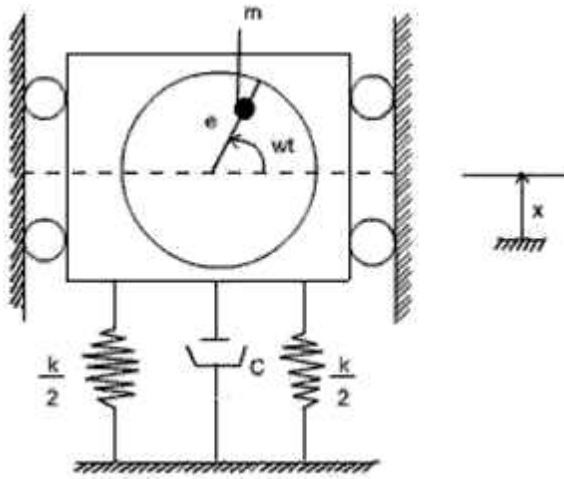

Figure : Vibrating system with rotating unbalance

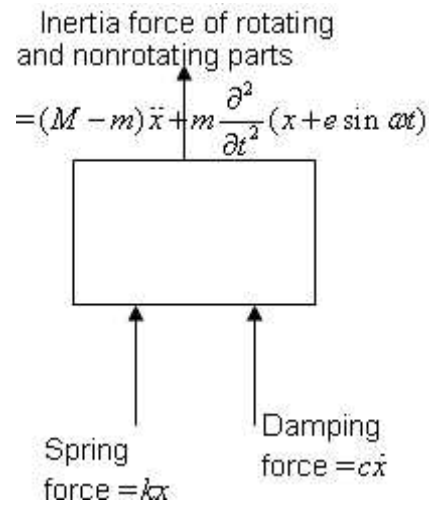

Figure : Freebody diagram of the system

Let  $x$  be the displacement of the nonrotating mass  $(M-m)$  from the static equilibrium position, then the displacement of the rotating mass  $m$  is  $x + e \sin \omega t$

From the freebody diagram of the system shown in figure, the equation of motion is

$$M\ddot{x} + kx + c\dot{x} = me\omega^2 \sin \omega t$$

This equation is same as equation (1) where  $F$  is replaced by  $me\omega^2$ . So from the force polygon as shown in figure 4.3

$$me\omega^2 = \sqrt{\{(-M\omega^2 + k)^2 + c\omega^2\}} X^2$$

$$X = \frac{me\omega^2}{\sqrt{(k - M\omega^2)^2 + (c\omega)^2}}$$

or

$$\frac{X}{e} = \frac{\frac{m\omega}{M}}{\sqrt{\left(\frac{k}{M} - \omega^2\right)^2 + \left(\frac{c}{M}\omega\right)^2}}$$

So the complete solution becomes

$$x(t) = x_1 e^{-\zeta\omega_n t} \sin\left(\sqrt{1 - \zeta^2} \omega_n t + \phi_1\right) + \frac{me\omega^2}{\sqrt{(k - M\omega^2)^2 + (c\omega)^2}} \sin(\omega t - \phi)$$

#### **VIBRATION ISOLATION AND TRANSMISSIBILITY:**

When a machine is operating, it is subjected to several time varying forces because of which it tends to exhibit vibrations. In the process, some of these forces are transmitted to the foundation – which could undermine the life of the foundation and also affect the operation of any other machine on the same foundation. Hence it is of interest to minimize this force transmission. Similarly when a system is subjected to ground motion, part of the ground motion is transmitted to the system as we just discussed e.g., an automobile going on an uneven road; an instrument mounted on the vibrating surface of an aircraft etc. In these cases, we wish to minimize the motion transmitted from the ground to the system. Such considerations are used in the design of machine foundations and in order to understand some of the basic issues involved, we will study this problem based on the single d.o.f model discussed so far.

we get the expression for force transmitted to the base as follows:

$$X_0 = X_g \sqrt{\frac{k^2 + (c\Omega)^2}{(k - (m\Omega)^2)^2 + (c\Omega)^2}}$$

### **Vibration Isolators:**

Consider a vibrating machine; bolted to a rigid floor (Figure 2a). The force transmitted to the floor is equal to the force generated in the machine. The transmitted force can be decreased by adding a suspension and damping elements (often called vibration isolators) Figure 2b , or by adding what is called an inertia block, a large mass (usually a block of cast concrete), directly attached to the machine (Figure 2c). Another option is to add an additional level of mass (sometimes called a seismic mass, again a block of cast concrete) and suspension

a) Machine bolted to a rigid foundation

b) Supported on isolation springs, rigid foundation

c) machine attached to an inertial block.

d) Supported on isolation springs, non-rigid foundation (such as a floor); or machine on isolation springs, seismic mass and second level of isolator springs

When oscillatory forces arise unavoidably in machines it is usually desired to prevent these forces from being transmitted to the surroundings. For example, some unbalanced forces are inevitable in a car engine, and it is uncomfortable if these are wholly transmitted to the car body. The usual solution is to mount the source of vibration on sprung supports. Vibration isolation is measured in terms of the motion or force transmitted to the foundation. The lesser the force or motion transmitted the greater the vibration isolation. Suppose that the foundation is effectively rigid and that only one direction of movement is effectively excited so that the system can be treated as having only one degree of freedom.

### **RESPONSE WITHOUT DAMPING:**

The amplitude of the force transmitted to the foundations is Where  $k$  is the Stiffness of the support and  $x(t)$  is the displacement of the mass  $m$ .

The governing equation can be determined by considering that the total forcing on the machine is equal to its mass multiplied by its acceleration (Newton's second law)



The ratio (transmitted force amplitude) / (applied force amplitude) is called the **transmissibility**.

$$\text{Transmissibility} = \left| \frac{F_T}{F} \right| = \frac{1}{\left| 1 - \frac{\omega^2}{\omega_n^2} \right|} = \frac{1}{\left| 1 - \frac{f^2}{f_n^2} \right|}$$

The transmissibility can never be zero but will be less than 1 providing  $\frac{\omega}{\omega_n} > \sqrt{2}$  or  $\frac{f}{f_n} > \sqrt{2}$  otherwise it will be greater than 1.

## SOLVED PROBLEMS

1. Derive the relation for the displacement of mass from the equilibrium position of the damped vibration system with harmonic forcing.

Consider a system consisting of spring, mass and damper as shown in Fig. 23.19. Let the system is acted upon by an external periodic (*i.e.* simple harmonic) disturbing force,

$$F_x = F \cos \omega \cdot t$$

where  $F =$  Static force, and

$\omega =$  Angular velocity of the periodic disturbing force.

When the system is constrained to move in vertical guides, it has only one degree of freedom.

Let at sometime  $t$ , the mass is displaced downwards through a distance  $x$  from its mean position.

The equation of motion may be written

$$m \times \frac{d^2 x}{dt^2} + c \times \frac{dx}{dt} + s \cdot x = F \cos \omega t$$

or

$$m \times \frac{d^2 x}{dt^2} + c \times \frac{dx}{dt} + s \cdot x = F \cos \omega t$$

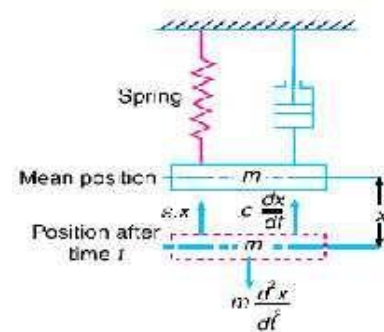

Fig. 23.19. Frequency of under damped forced vibrations.

This equation of motion may be solved either by differential equation method or by graphical method as discussed below :

### 1. Differential equation method

The equation (i) is a differential equation of the second degree whose right hand side is some

function in  $t$ . The solution of such type of differential equation consists of two parts ;

one part is the complementary function and the second is particular integral. Therefore the solution may be written as

$$x = x_1 + x_2$$

where  $x_1$  = Complementary function, and  $x_2$  = Particular integral.

The complementary function is same as discussed in the previous article, *i.e.*

$$x_1 \propto Ce^{-at} \cos(\omega_d t - \theta) \dots (ii) \text{ where } C \text{ and } \theta \text{ are constants. Let us now}$$

find the value of particular integral as discussed below :

Let the particular integral of equation (i) is given by

$$x_2 = B_1 \sin \omega t + B_2 \cos \omega t \dots (\text{where } B_1 \text{ and } B_2 \text{ are constants})$$

$$\frac{dx}{dt} = B_1 \omega \cos \omega t - B_2 \omega \sin \omega t$$

and  $\frac{d^2x}{dt^2} = -B_1 \omega^2 \sin \omega t - B_2 \omega^2 \cos \omega t$

Substituting these values in the given differential equation (i), we get

$$m(-B_1 \omega^2 \sin \omega t - B_2 \omega^2 \cos \omega t) + c(B_1 \omega \cos \omega t - B_2 \omega \sin \omega t) + s(B_1 \sin \omega t + B_2 \cos \omega t) = F \cos \omega t$$

or  $(-mB_1 \omega^2 + c\omega B_2 + sB_1) \sin \omega t + (m\omega^2 B_2 + c\omega B_1 + sB_2) \cos \omega t = F \cos \omega t$

Now from equation (iii)

$$(s - m\omega^2) B_1 - c\omega B_2$$

$$\therefore B_2 = \frac{s - m\omega^2}{c\omega} \times B_1 \quad \dots (v)$$

Substituting the value of  $B_2$  in equation (ii)

$$c\omega B_1 + \frac{(s - m\omega^2)(s - m\omega^2)}{c\omega} \times B_1 = F$$

$$c^2\omega^2 B_1 + (s - m\omega^2)^2 B_1 = c\omega F$$

$$B_1 [c^2\omega^2 + (s - m\omega^2)^2] = c\omega F$$

$$\therefore B_1 = \frac{c\omega F}{c^2\omega^2 + (s - m\omega^2)^2}$$

$$= \frac{c\omega F'}{c^2\omega^2 + (s - m\omega^2)^2} \times \sin \omega t - \frac{F'(s - m\omega^2)}{c^2\omega^2 + (s - m\omega^2)^2} \times \cos \omega t$$

$$= \frac{F'}{c^2\omega^2 + (s - m\omega^2)^2} [c\omega \sin \omega t + (s - m\omega^2) \cos \omega t] \quad \dots (vi)$$

Let  $c\omega = X \sin \phi$ ; and  $s - m\omega^2 = X \cos \phi$

$$\therefore X = \sqrt{c^2\omega^2 + (s - m\omega^2)^2} \quad \dots \text{(By squaring and adding)}$$

and  $\tan \phi = \frac{c\omega}{s - m\omega^2} \quad \text{or} \quad \phi = \tan^{-1} \left( \frac{c\omega}{s - m\omega^2} \right)$

Now the equation (vi) may be written as

$$x_2 = \frac{F'}{c^2\omega^2 + (s - m\omega^2)^2} [X \sin \phi \sin \omega t + X \cos \phi \cos \omega t]$$

$$= \frac{F.X}{c^2\omega^2 + (s - m\omega^2)^2} \times \cos(\omega t - \phi)$$

$$= \frac{F' \sqrt{c^2\omega^2 + (s - m\omega^2)^2}}{c^2\omega^2 + (s - m\omega^2)^2} \times \cos(\omega t - \phi)$$

$$= \frac{F}{\sqrt{c^2\omega^2 + (s - m\omega^2)^2}} \times \cos(\omega t - \phi)$$

or  $[(s - m\omega^2) B_1 - c\omega B_2] \sin \omega t + [c\omega B_1 - (s - m\omega^2) B_2] \cos \omega t$   
 $= F \cos \omega t + 0 \sin \omega t$

Comparing the coefficients of  $\sin \omega t$  and  $\cos \omega t$  on the left hand side and right hand side separately, we get

$$(s - m\omega^2) B_1 - c\omega B_2 = 0 \quad \dots (iii)$$

and  $c\omega B_1 + (s - m\omega^2) B_2 = F' \quad \dots (iv)$

and

$$B_2 = \frac{s - m\omega^2}{c\omega} \times \frac{c\omega F}{c^2\omega^2 + (s - m\omega^2)^2} \quad \dots \text{ [From equation (10)]}$$

$$= \frac{F(s - m\omega^2)}{c^2\omega^2 + (s - m\omega^2)^2}$$

∴ The particular integral of the differential equation (7) is

$$x_2 = B_1 \sin \omega t + B_2 \cos \omega t$$

This equation shows that motion is simple harmonic whose circular frequency is  $\omega$  and the

amplitude is  $\frac{F}{\sqrt{c^2\omega^2 + (s - m\omega^2)^2}}$ .

**Solution.** Given :  $m = 10 \text{ kg}$ ;  $s = 10 \text{ N/mm} = 10 \times 10^3 \text{ N/m}$ ;  $x_2 = \frac{x_1}{10}$

Since the periodic force,  $F_x = F \cos \omega t = 150 \cos 50t$ , therefore

Static force,  $F = 150 \text{ N}$

and angular velocity of the periodic disturbing force:

$$\omega = 50 \text{ rad/s}$$

We know that angular speed or natural circular frequency of free vibrations,

$$\omega_n = \sqrt{\frac{s}{m}} = \sqrt{\frac{10 \times 10^3}{10}} = 31.6 \text{ rad/s}$$

#### Amplitude of the forced vibrations

Since the amplitude decreases to 1/10th of the initial value in four complete oscillations, therefore, the ratio of initial amplitude ( $x_1$ ) to the final amplitude after four complete oscillations ( $x_5$ ) is given by

$$\frac{x_1}{x_5} = \frac{x_1}{x_2} \times \frac{x_2}{x_3} \times \frac{x_3}{x_4} \times \frac{x_4}{x_5} = \left(\frac{x_1}{x_2}\right)^4 \quad \dots \left(\because \frac{x_1}{x_2} = \frac{x_2}{x_3} = \frac{x_3}{x_4} = \frac{x_4}{x_5}\right)$$

$$\therefore \frac{x_1}{x_2} = \left(\frac{x_1}{x_5}\right)^{1/4} = \left(\frac{x_1}{x_1/10}\right)^{1/4} = (10)^{1/4} = 1.78 \quad \dots \left(x_5 = \frac{x_1}{10}\right)$$

We know that

$$\log_e \left(\frac{x_1}{x_2}\right) = a \times \frac{2\pi}{\sqrt{(\omega_n)^2 - a^2}}$$

$$\log_e 1.78 = a \times \frac{2\pi}{\sqrt{(31.6)^2 - a^2}} \quad \text{or} \quad 0.576 = \frac{a \times 2\pi}{\sqrt{1000 - a^2}}$$

2. A mass of 10 kg is suspended from one end of a helical spring, the other end being fixed. The stiffness of the spring is 10 N/mm. The viscous damping causes the amplitude to decrease to one-tenth of the initial value in four complete oscillations. If a periodic force of  $150 \cos 50 t \text{ N}$  is applied at the mass in the vertical direction, find the amplitude of the forced vibrations. What is its value of resonance ?

We know that amplitude of the forced vibrations,

$$x_{max} = \frac{x_0}{\sqrt{\frac{c^2 \omega^2}{s^2} + \left[1 - \frac{\omega^2}{(\omega_n)^2}\right]^2}}$$

$$= \frac{0.015}{\sqrt{\frac{(57.74)^2 (50)^2}{(10 \times 10^3)^2} + \left[1 - \left(\frac{50}{31.6}\right)^2\right]^2}} = \frac{0.015}{\sqrt{0.083 + 2.25}}$$

Squaring both sides and rearranging,

$$39.832 a^2 = 332 \quad \text{or} \quad a^2 = 8.335 \quad \text{or} \quad a = 2.887$$

We know that  $a = c/2m$  or  $c = a \times 2m = 2.887 \times 2 \times 10 = 57.74 \text{ N/m/s}$   
and deflection of the system produced by the static force  $F$ ,

$$x_0 = F/s = 150/10 \times 10^3 = 0.015 \text{ m}$$

$$= \frac{0.015}{1.53} = 9.8 \times 10^{-3} \text{ m} = 9.8 \text{ mm Ans.}$$

### Amplitude of forced vibrations at resonance

We know that amplitude of forced vibrations at resonance,

$$x_{max} = x_0 \times \frac{s}{c \omega_n} = 0.015 \times \frac{10 \times 10^3}{57.54 \times 31.6} = 0.0822 \text{ m} = 82.2 \text{ mm Ans.}$$

We know that transmissibility ratio ( $\epsilon$ ),

$$\frac{1}{11} = \frac{1}{\left(\frac{\omega}{\omega_n}\right)^2 - 1} = \frac{(\omega_n)^2}{\omega^2 - (\omega_n)^2} = \frac{(\omega_n)^2}{(157.1)^2 - (\omega_n)^2}$$

$$\text{or} \quad (157.1)^2 - (\omega_n)^2 = 11 (\omega_n)^2 \quad \text{or} \quad (\omega_n)^2 = 2057 \quad \text{or} \quad \omega_n = 45.35 \text{ rad/s}$$

3. The mass of an electric motor is 120 kg and it runs at 1500 r.p.m. The armature mass is 35 kg and its C.G. lies 0.5 mm from the axis of rotation. The motor is mounted on five springs of negligible damping so that the force transmitted is one-eleventh of the impressed force. Assume that the mass of the motor is equally distributed among the five springs. Determine : 1. stiffness of each spring; 2. dynamic force transmitted to the base at the operating speed; and 3. natural frequency of the system.

**Solution.** Given  $m_1 = 120 \text{ kg}$ ;  $m_2 = 35 \text{ kg}$ ;  $r = 0.5 \text{ mm} = 5 \times 10^{-4} \text{ m}$ ;  $\epsilon = 1/11$ ;  
 $N = 1500 \text{ r.p.m.}$  or  $\omega = 2\pi \times 1500/60 = 157.1 \text{ rad/s}$ ;

### 1. Stiffness of each spring

Let

$s$  - Combined stiffness of the spring in N-m, and

$\omega_n$  = Natural circular frequency of vibration of the machine in rad/s.

**2. Dynamic force transmitted to the base at the operating speed (i.e. 1500 r.p.m. or 157.1 rad/s)**

We know that maximum unbalanced force on the motor due to armature mass,

$$F = m_2 \omega^2 r = 35 (157.1)^2 5 \times 10^{-4} = 432 \text{ N}$$

∴ Dynamic force transmitted to the base,

$$F_1 = c.F = \frac{1}{11} \times 432 = 39.27 \text{ N Ans}$$

**3. Natural frequency of the system**

We have calculated above that the natural frequency of the system,

$$\omega_n = 45.35 \text{ rad/s Ans.}$$

- Felt
- Cork
- Metallic Springs

Cork is suitable for compressive loads because it is not perfectly elastic. At high loads it becomes more flexible.

**6. Show that for effective isolation of vibration, frequency ratio  $r > \sqrt{2}$ .**

When  $r > \sqrt{2}$ , then transmissibility is less than one for all values of damping factor.

This means that the transmitted force is always less than the excited force.

**7. Sketch the graph for  $(\omega/\omega_n)$  Vs Transmissibility for different values of damping factor.**

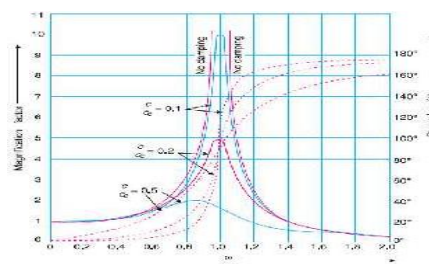

**8. What are the methods of isolating the vibration?**

- High speed engines/machines mounted on foundation and supports cause vibrations of excessive amplitude because of the unbalanced forces. It can be minimized by providing “spring-damper” , etc.
- The materials used for vibration isolation are rubber, felt cork, etc. These are placed between the

foundation and vibrating body.

**PART-B**

**1. Derive the relation for the displacement of mass from the equilibrium position of the damped vibration system with harmonic forcing. ?**

Consider a system consisting of spring, mass and damper as shown in Fig. 23.19. Let the system is acted upon by an external periodic (*i.e.* simple harmonic) disturbing force,

$$F_x = F \cos \omega . t$$

where  $F$  = Static force, and

$\omega$  = Angular velocity of the periodic disturbing force.

When the system is constrained to move in vertical guides, it has only one degree of freedom. Let at sometime  $t$ , the mass is displaced downwards through a distance  $x$  from its mean position.

The equation of motion may be written as,

$$m \times \frac{d^2 x}{dt^2} + c \times \frac{dx}{dt} + s \cdot x = F \cos \omega t$$

or  $m \times \frac{d^2 x}{dt^2} + c \times \frac{dx}{dt} + s \cdot x = F \cos \omega t$

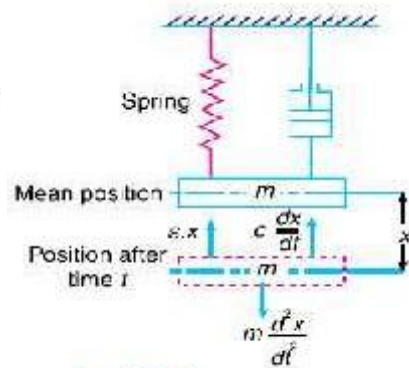

Fig. 23.19. Frequency of under damped forced vibrations.

1. A mass of 10 kg is suspended from one end of a helical spring, the other end being fixed. The stiffness of the spring is 10 N/mm. The viscous damping causes the amplitude to decrease to one-tenth of the initial value in four complete oscillations. If a periodic force of  $150\cos 50 t$  N is applied at the mass in the vertical direction, find the amplitude of the forced vibrations. What is its value of resonance?

**Solution.** Given :  $m = 10 \text{ kg}$  ;  $s = 10 \text{ N/mm} = 10 \times 10^3 \text{ N/m}$  ;  $x_2 = \frac{x_1}{10}$

Since the periodic force,  $F_x = F \cos \omega t = 150 \cos 50 t$ , therefore

Static force,  $F = 150 \text{ N}$

and angular velocity of the periodic disturbing force,

$$\omega = 50 \text{ rad/s}$$

We know that angular speed or natural circular frequency of free vibrations,

$$\omega_n = \sqrt{\frac{s}{m}} = \sqrt{\frac{10 \times 10^3}{10}} = 31.6 \text{ rad/s}$$

#### *Amplitude of the forced vibrations*

Since the amplitude decreases to 1/10th of the initial value in four complete oscillations, therefore, the ratio of initial amplitude ( $x_1$ ) to the final amplitude after four complete oscillations ( $x_5$ ) is given by

$$\frac{x_1}{x_5} = \frac{x_1}{x_2} \times \frac{x_2}{x_3} \times \frac{x_3}{x_4} \times \frac{x_4}{x_5} = \left( \frac{x_1}{x_2} \right)^4 \quad \dots \left( \because \frac{x_1}{x_2} = \frac{x_2}{x_3} = \frac{x_3}{x_4} = \frac{x_4}{x_5} \right)$$

$$\therefore \frac{x_1}{x_2} = \left( \frac{x_1}{x_5} \right)^{1/4} = \left( \frac{x_1}{x_1/10} \right)^{1/4} = (10)^{1/4} = 1.78 \quad \dots \left( x_5 = \frac{x_1}{10} \right)$$

We know that

$$\log_e \left( \frac{x_1}{x_2} \right) = a \times \frac{2\pi}{\sqrt{(\omega_n)^2 - a^2}}$$

We know that amplitude of the forced vibrations,

$$x_{max} = \frac{x_s}{\sqrt{\frac{c^2 \omega^2}{s^2} + \left[ 1 - \frac{\omega^2}{(\omega_n)^2} \right]^2}}$$

$$= \frac{0.015}{\sqrt{\frac{(57.74)^2 (50)^2}{(10 \times 10^3)^2} + \left[ 1 - \left( \frac{50}{31.6} \right)^2 \right]^2}} = \frac{0.015}{\sqrt{0.083 + 2.25}}$$



Squaring both sides and rearranging,

$$39.832 a^2 = 332 \quad \text{or} \quad a^2 = 8.335 \quad \text{or} \quad a = 2.887$$

We know that  $a = c/2m$  or  $c = a \times 2m = 2.887 \times 2 \times 10^3 = 57.74 \text{ N/m/s}$   
and deflection of the system produced by the static force  $F$ ,

$$x_0 = F/s = 150/10 \times 10^3 = 0.015 \text{ m}$$

2. The mass of an electric motor is 120 kg and it runs at 1500 r.p.m. The armature mass is 35 kg and its C.G. lies 0.5 mm from the axis of rotation. The motor is mounted on five springs of negligible damping so that the force transmitted is one-eleventh of the impressed force. Assume that the mass of the motor is equally distributed among the five springs. Determine : 1. stiffness of each spring; 2. dynamic force transmitted to the base at the operating speed; and 3. natural frequency of the system. ?

**Solution.** Given  $m_1 = 120 \text{ kg}$ ;  $m_2 = 35 \text{ kg}$ ;  $r = 0.5 \text{ mm} = 5 \times 10^{-4} \text{ m}$ ;  $e = 1/11$ ;  
 $N = 1500 \text{ r.p.m.}$  or  $\omega = 2\pi \times 1500/60 = 157.1 \text{ rad/s}$ ;

#### 1. Stiffness of each spring

Let

$s$  = Combined stiffness of the spring in N-m, and

$\omega_n$  = Natural circular frequency of vibration of the machine in rad/s.

$$= \frac{0.015}{1.53} = 9.8 \times 10^{-3} \text{ m} = 9.8 \text{ mm Ans.}$$

#### Amplitude of forced vibrations at resonance

We know that amplitude of forced vibrations at resonance,

$$x_{max} = x_0 \times \frac{s}{c\omega_n} = 0.015 \times \frac{10 \times 10^3}{57.54 \times 31.6} = 0.0822 \text{ m} = 82.2 \text{ mm Ans.}$$

We know that  $\omega_n = \sqrt{s/m_1}$

$$s = m_1 (\omega_n)^2 = 120 \times 2057 = 246\,840 \text{ N/m}$$

Since these are five springs, therefore stiffness of each spring

$$= 246\,840 / 5 = 49\,368 \text{ N/m} \quad \text{Ans.}$$

We know that transmissibility ratio ( $\epsilon$ ),

$$\frac{1}{11} = \frac{1}{\left(\frac{\omega}{\omega_n}\right)^2 - 1} = \frac{(\omega_n)^2}{\omega^2 - (\omega_n)^2} = \frac{(\omega_n)^2}{(157.1)^2 - (\omega_n)^2}$$

or  $(157.1)^2 - (\omega_n)^2 = 11(\omega_n)^2$  or  $(\omega_n)^2 = 2057$  or  $\omega_n = 45.35 \text{ rad/s}$

2. *Dynamic force transmitted to the base at the operating speed (i.e. 1500 r.p.m. or 157.1 rad/s)*

We know that maximum unbalanced force on the motor due to armature mass,

$$F = m_r \omega^2 = 35 (157.1)^2 \times 10^{-4} = 432 \text{ N}$$

$\therefore$  Dynamic force transmitted to the base,

$$F_T = \epsilon F = \frac{1}{11} \times 432 = 39.27 \text{ N} \quad \text{Ans.}$$

### 3. *Natural frequency of the system*

We have calculated above that the natural frequency of the system,

$$\omega_n = 45.35 \text{ rad/s} \quad \text{Ans.}$$

What do you understand by transmissibility? Describe the method of finding the transmissibility ratio from unbalanced machine supported with foundation.

A little consideration will show that when an unbalanced machine is installed on the foundation, it produces vibration in the foundation. In order to prevent these vibrations or to minimize the transmission of forces to the foundation, the machines are mounted on springs and dampers or on some vibration isolating material, as shown in Fig. 23.22. The arrangement is assumed to have one degree of freedom, *i.e.* it can move up and down only.

It may be noted that when a periodic (*i.e.* simple harmonic) disturbing force  $F \cos \omega t$  is applied to a machine of mass  $m$  supported by a spring of stiffness  $s$ , then the force is transmitted by means of the spring and the damper or dashpot to the fixed support or foundation.

The ratio of the force transmitted ( $F_T$ ) to the force applied ( $F$ ) is known as the **isolation factor** or **transmissibility ratio** of the spring support.

We have discussed above that the force transmitted to the foundation consists of the following two forces :

1. Spring force or elastic force which is equal to  $s \cdot x_{max}$ , and

2. Damping force which is equal to  $c \cdot \omega \cdot x_{max}$ .