



**INSTITUTE OF AERONAUTICAL ENGINEERING**  
**(Autonomous)**  
Dundigal, Hyderabad -500 043  
**AERONAUTICAL ENGINEERING**

**COURSE LECTURE NOTES**

<b>Course Name</b>	<b>DESIGN FOR MANUFACTURING AND ASSEMBLY</b>
<b>Course Code</b>	AME520
<b>Programme</b>	B.Tech
<b>Semester</b>	VIII
<b>Course Coordinator</b>	Mr. A. Venuprasad Assistant Professor
<b>Course Faculty</b>	Mr. A. Venuprasad Assistant Professor
<b>Lecture Numbers</b>	1-63
<b>Topic Covered</b>	All

**COURSE OBJECTIVES (COs):**

<b>The course should enable the students to:</b>	
I	Understand various general design rules for manufacture ability and criteria for material selection.
II	Apply various machining process and tolerance aspects in machining.
III	Analyze the design considerations for casting and welding process.
IV	Apply the conceptual design factors to be considered in forging, extrusion and sheet metal work, design guidelines for manual assembly and development of DFA methodology

**COURSE LEARNING OUTCOMES (CLOs):**

**Students, who complete the course, will have demonstrated the ability to do the following:**

AME010.01	Identify and understand of basic concepts of DFM and DFA
AME010.02	Understand and Apply concepts of Generative DFMA
AME010.03	Understand the Various types of materials, its classification, suitable materials for product design
AME010.04	Understand the selection of manufacturing sequences and optimal selection
AME010.05	Identify the reasons for optimal selection of machining parameters.
AME010.06	Identify the various casting design, machining design, designing of formed components
<b>CLOCode</b>	<b>At the end of the course, the student will have the ability to:</b>

AME010.07	Identify various design recommendation for permanent joining such as welding, soldering and brazing
AME010.08	understand the different design factors for forging, closed dies forging design
AME010.09	Apply the different Design guidelines for extruded sections
AME010.10	Understand various design principles for punching, blanking, bending, deep drawing.
AME010.11	Understand the different conventional approach and Assembly optimization processes
AME010.12	Create the knowledge on cost consciousness & an awareness of Designers' accountability in the product design lifecycle.
AME010.13	Understand the cost factors that play a part in DFA
AME010.14	Understand the general design guidelines for manual assembly and development of the systematic DFA methodology
AME010.15	Using CAD, apply design for manufacturing and assembly techniques to mechanical designs.
AME010.16	Understand the effect of symmetry effect of chamfer design on insertion operations, estimation of insertion time.

## SYLLABUS

<b>UNIT-I</b>	<b>INTRODUCTION</b>	<b>Classes: 09</b>
Introduction: Design philosophy steps in design process, general design rules for manufacturability, basic principles of design Ling for economical production, creativity in design; Materials selection of materials for design developments in material technology, criteria for material selection, material selection interrelationship with process selection process selection charts.		
<b>UNIT-II</b>	<b>MACHINING PROCESS, CASTING</b>	<b>Classes: 09</b>
Machining process: Overview of various machining processes, general design rules for machining, dimensional tolerance and surface roughness, design for machining, ease of redesigning of components for machining ease with suitable examples. General design recommendations for machined parts.		
<b>UNIT-III</b>	<b>METAL JOINING, FORMING</b>	<b>Classes: 09</b>
Metal casting: Appraisal of various casting processes, selection of casting processes, general design considerations for casting, casting tolerances, use of solidification simulation in casting design, product design rules for sand casting Metal joining: Appraisal of various welding processes, factors in design of weldments, general design guidelines, pre and post treatment of welds, effects of thermal stresses in weld joints, design of brazed joints;		
<b>UNIT-IV</b>	<b>DESIGN FOR FORGING</b>	<b>Classes: 09</b>
Forging, design factors for forging, closed dies forging design, parting lines of die drop forging die design general design recommendations. extrusion and sheet metal work: Design guidelines for extruded sections, design principles for punching, blanking, bending, deep drawing, Keeler Goodman forming line diagram, component design for blanking.		
<b>UNIT-V</b>	<b>DESIGN FOR ASSEMBLY AND AUTOMATION</b>	<b>Classes: 09</b>
Design for assembly: General design guidelines for manual assembly, development of systematic DFA methodology, assembly efficiency, classification system for manual handling, classification system for manual insertion and fastening, effect of part symmetry on handling time.		

**Text Books:**

1. Geoffrey Boothroyd, —Assembly Automation and Product Designl, Marcel Dekker Inc., NY, 1<sup>st</sup> Edition, 2013.
2. George E, Dieter, —Engineering Design - Material & Processing Approachl, McGraw-Hill, 2<sup>nd</sup> Edition, 2000.
3. Geoffrey Boothroyd, —Hand Book of Product Designl, Marcel and Dekken, 1<sup>st</sup> Edition, 2013.
4. Geoffrey Boothroyd, Peter Dewhurst, Winston —Product Design for Manufacturing and Assemblyl, CRC Press, 1<sup>st</sup> Edition, 2010.

**Reference Books:**

1. Geoffrey Boothroyd, —Hand Book of Product Designl, Marcel and Dekken, 1<sup>st</sup> Edition, 2013.
2. Geoffrey Boothroyd, Peter Dewhurst, Winston —Product Design for Manufacturing and Assemblyl, CRC Press, 1<sup>st</sup> Edition, 2010.

## UNIT-I

### INTRODUCTION

What is -DFMA? The concept of DFM (Design for Manufacture) is not new, it dates back as early as 1788 when LeBlanc, a Frenchman, devised the concept of inter-changeable parts in the manufacture of muskets which previously were individually handmade. DFM is the practice of designing products keeping manufacturing in mind. -Design for manufacture means the design for ease of manufacture for the collection of parts that will form the product after assembly. Similarly DFA is called Design for Assembly. DFA is the practice of designing product with assembly in mind. -Design for assembly means the design of the product for ease of assembly. So design for Manufacture and assembly is the combination of DFM and DFA as shown in Figure 1.1

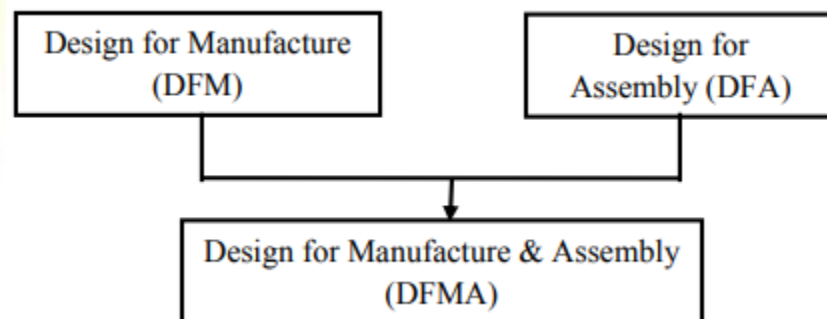
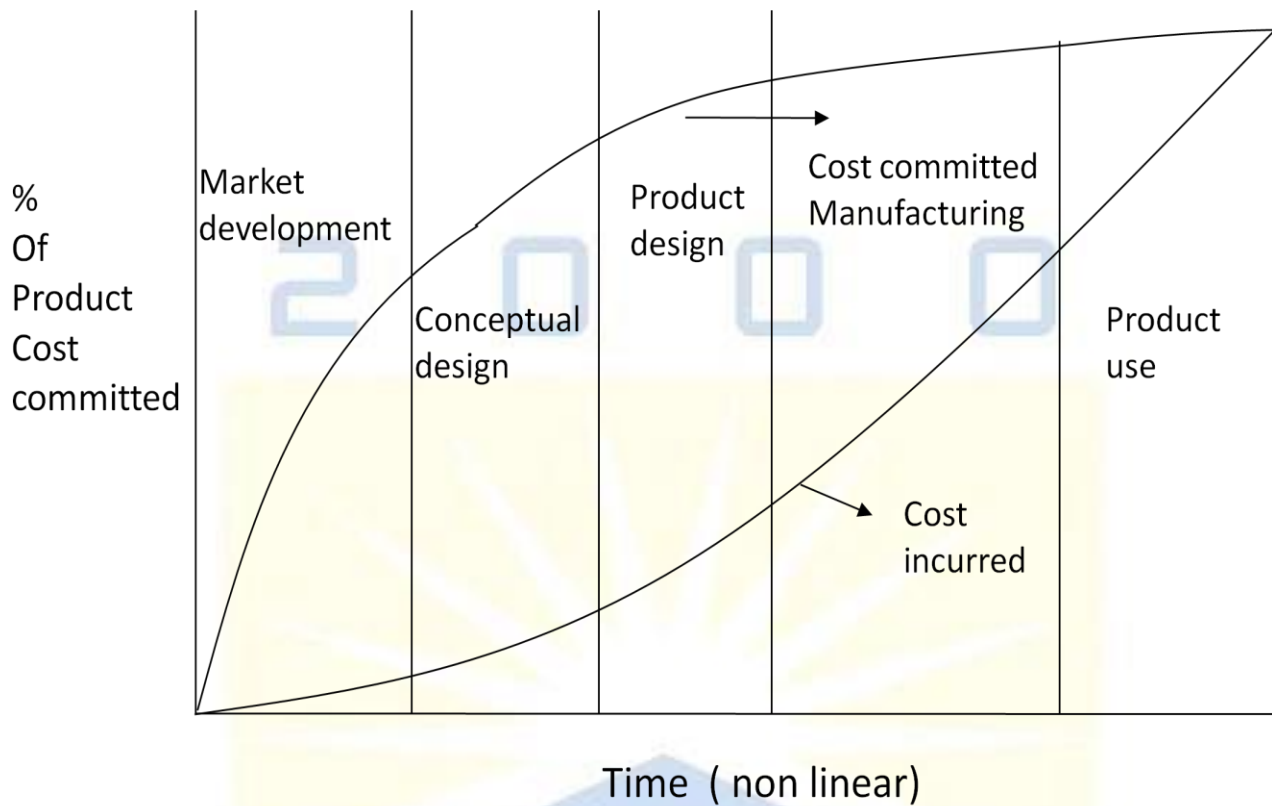

Figure 1.1: Definition of Design for Manufacture & Assembly (DFMA)

DFMA is used for three main activities:

1. As the basis for concurrent engineering studies to provide guidance to the design team in simplifying the product structure to reduce manufacturing and assembly costs, and to quantify the improvements.
2. As a benchmarking tool to study competitors' products and quantify manufacturing and assembly difficulties.
3. As a should-cost tool to help control costs and to help negotiate suppliers contracts.



### Product cost Commitment during phases of the design process

-Decisions made in the design process cost very little in terms of the overall product cost but have a major effect on the cost of the product.¶

-You cannot compensate in manufacturing for defects introduced in the design phase¶

-The design process should be conducted so as to develop quality, cost – competitive products in the shortest time possible¶

### TYPES OF DESIGNS

- Original design → Innovation  
eg: Microprocessor
- Adaptive design → Novel application  
eg: inkjet printing concept  
for rapid prototyping
- Redesign : Without any change in concept of the original design
- Variant design : changing some of the design parameters
- Selection design : Selecting the components with the needed performance, quality and cost from the catalogs of potential vendors
- Industrial design : Appeal of product to human senses.

## Step in Design Process:

Steps for applying DFMA during product design:

The following steps are followed when DFMA used in the design process.

- DFA analysis leading to simplification of the product structure
- Early cost estimation of parts for both original design and modified design
- Selecting best material and process to be used
- After final selection of material and process carry out a thorough analysis of DFM

Figure 1.2 depicts the flow diagram of various steps undertaken in a DFMA study using DFMA software. Figure

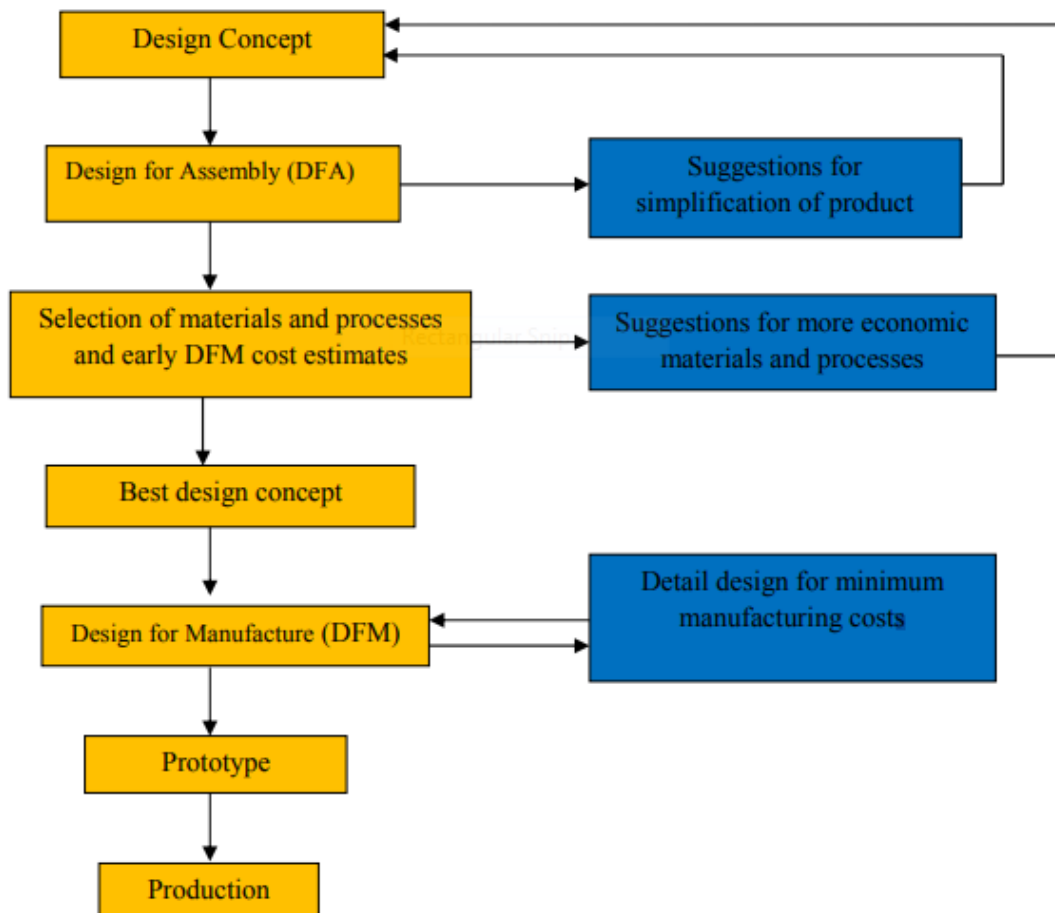

Figure 1.2: Common steps taken in a DFMA study

Design Concept Design for Assembly (DFA) Selection of materials and processes and early DFM cost estimates Best design concept Design for Manufacture (DFM) Production Prototype Suggestions for more economic materials and processes Suggestions for simplification of product structure.

## **Advantages of applying DFMA during product Design**

Today products are

- Tending to becoming more complex
- Made/required in increasingly large number
- Intended to satisfy a wide variation in user population
- Required to compete aggressively with similar products
- Required to consistently high quality

Through DFMA it is possible to produce competitively priced, high performance product at a minimal cost. The advantages of applying DFMA during product design are as follows:

- DFMA not only reduces the manufacturing cost of the product but it helps to reduce the time to market and quality of the product.
- DFMA provides a systematic procedure for analyzing a proposed design from the point of view of assembly and manufacture.
- Any reduction in the number of parts reduces the cost as well as the inventory.
- DFMA tools encouraged the dialogue between the designer and manufacturing engineer during the early stages of design.

### **General design rules for manufacturing ability:**

- (1) Product life, volume
- (2) Permissible tooling expenditure levels
- (3) Possible part shape categories and complexity levels
- (4) Service or environment requirements
- (5) Appearance factors
- (6) Accuracy factors

## **Materials:**

### **Relation of Materials Selection to Design:**

An incorrectly chosen material can lead not only to failure of the part but also to excessive life-cycle cost. Selecting the best material for a part involves more than choosing both a material that has the properties to provide the necessary performance in service and the processing methods used to create the finished part (Fig. 1.3). A poorly chosen material can add to manufacturing cost. Properties of the material can be enhanced or diminished by processing, and that may affect the service performance of the part. Faced with the large number of combinations of materials and processes from which to choose, the materials selection task can only be done effectively by applying simplification and systemization. As design proceeds from concept design, to configuration and parametric design (embodiment design), and



to detail design, the material and process selection becomes more detailed. Figure 1.2 compares the design methods and tools used at each design stage with materials and processes selection.

At the concept level of design, essentially all materials and processes are considered in broad detail. The materials selection methodology and charts developed by Ashby 2 are highly appropriate at this stage.

The task is to determine whether each design concept will be made from metal, plastics, ceramic, composite, or wood, and to narrow it to a group of materials within that material family. The required precision of property data is rather low.

Note that if an innovative choice of material is to be made it must be done at the conceptual design phase because later in the design process too many decisions have been made to allow for a radical change. The emphasis at the embodiment phase of design is on determining the shape and size of a part using engineering analysis.

The designer will have decided on a class of materials and processes, such as a range of aluminum alloys, wrought and cast. The material properties must be known to a greater level of precision. At the parametric design step the alternatives will have narrowed to a single material and only a few manufacturing processes.

Here the emphasis will be on deciding on critical tolerances, optimizing for robust design and selecting the best manufacturing process using quality engineering and cost modeling methodologies. Depending on the importance of the part, materials properties may need to be known to a high level of precision.

This may require the development of a detailed database based on an extensive materials testing program. Thus, material and process selection is a progressive process of narrowing from a large universe of possibilities to a specific material and process (Fig. 1.4).



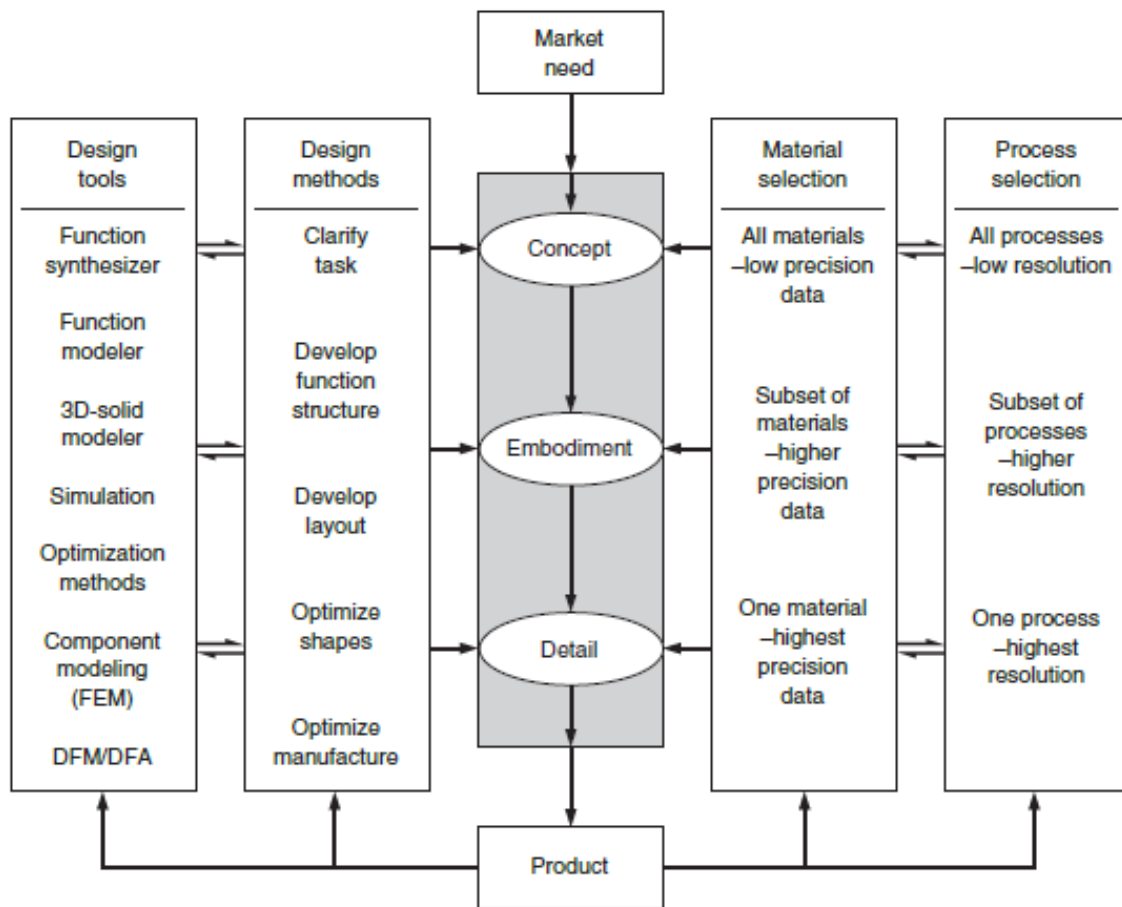

**Figure 1.4** Schematic of the design process, with design tools shown on the left and materials and process selection on the right. Shows the refining method used to arrive at the best combination of material and manufacturing process.

### General Criteria for Selection

Materials are selected on the basis of four general criteria:

- Performance characteristics (properties)
- Processing (manufacturing) characteristics
- Environmental profile
- Business considerations

Selection on the basis of performance characteristics is the process of matching values of the properties of the material with the requirements and constraints imposed by the design.

Selection on the basis of processing characteristics means finding the process that will form the material into the required shape with a minimum of defects at the least cost. Selection on the basis of an environmental profile is focused on predicting the impact of the material throughout its life cycle on the environment. As discussed in Sec. 8.9, environmental considerations are growing in importance because

of the dual pressures of greater consumer awareness and governmental regulation.

The chief business consideration that affects materials selection is the cost of the part that is made from the material. This considers both the purchase cost of the material and the cost to process it into a part. A more exact basis for selection is life-cycle cost, which includes the cost of replacing failed parts and the cost of disposing of the material at the end of its useful life.

**Selection charts:**

Each manufacturing process can be characterized by a set of attributes similar to what have been illustrated for materials in the earlier lectures. Process-Material matrix: Figure 1.8 represents a typical process-material matrix indicating the general compatibility between manufacturing process and engineering material. The processes are also broadly classified as shaping, joining and finishing. The dot indicates that the pair of the material and the process is compatible. For example, sand casting or die casting process cannot be used for processing of composite materials. Thus, an initial screening of processes for a given material can be easily performed based Figure 1.8.

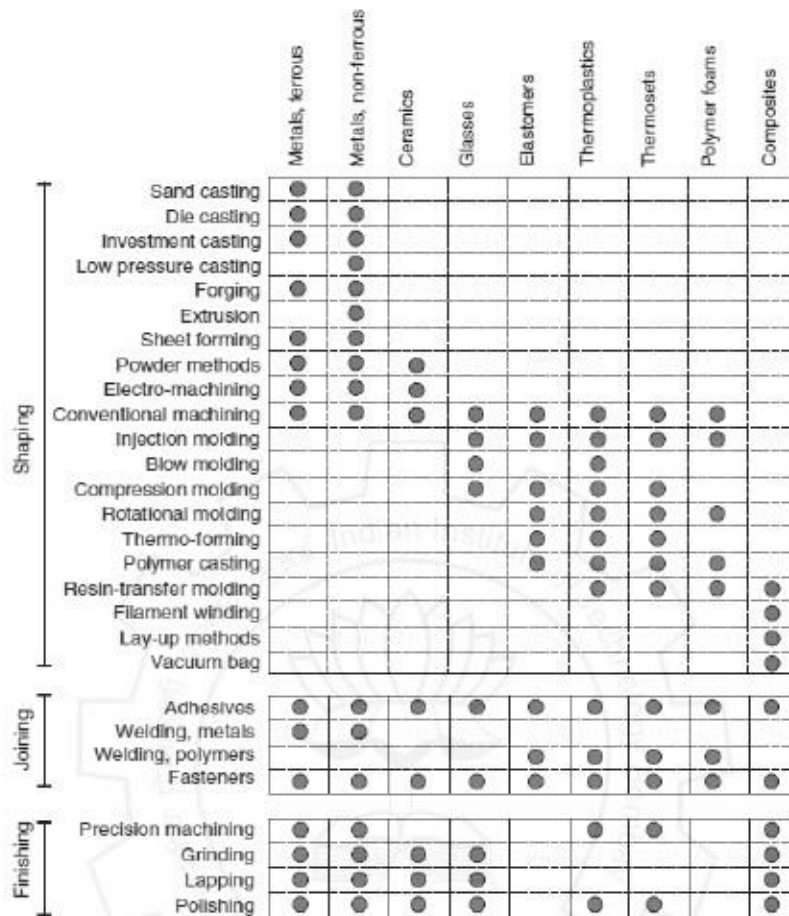

**Figure.1.7.** Process–Material matrix with the dot indicating a compatibility between the material and the corresponding manufacturing process [2]

**Process-Shape matrix:** Figure 3.8.3 presents a broad classification of different shapes that are commonly encountered in product design. Various manufacturing processes are capable of making these shapes.

For example, a typical turning operation creates axisymmetric shapes while extrusion, drawing and rolling make prismatic shapes – both circular and non-circular.

The sheet forming processes can make flat or dished shapes. Certain manufacturing processes can make three-dimensional shapes.

Figure 3.8.4 depicts a typical Process vis-à-vis Shape compatibility chart indicating the ability of various manufacturing processes in producing different shapes. Often a single process is unable to give the final shape of a product and it is necessary to combine two or more processes.

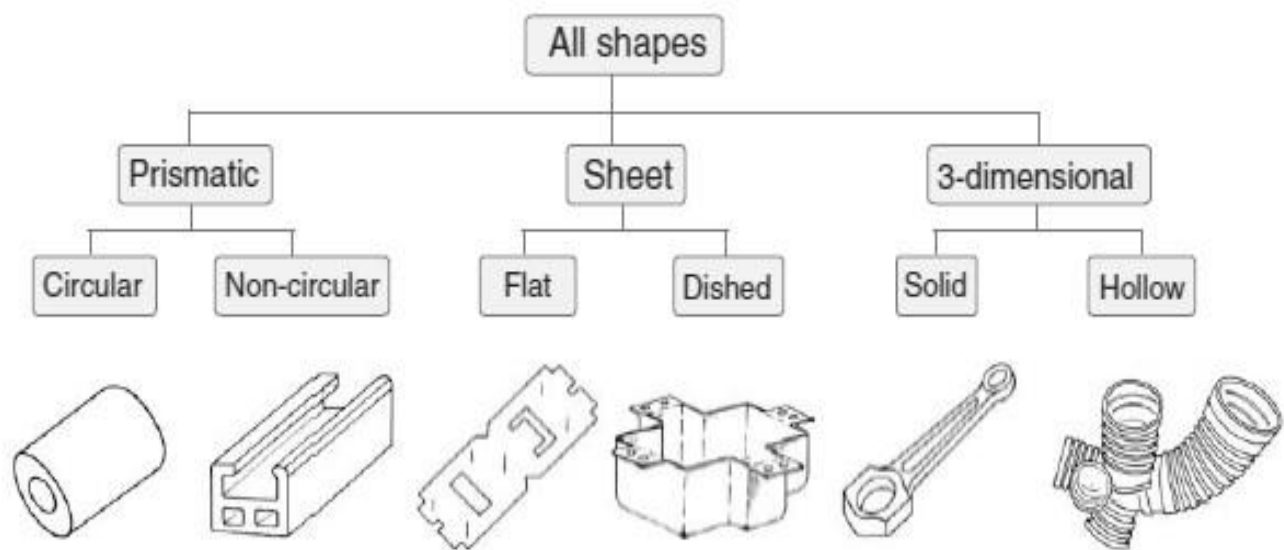
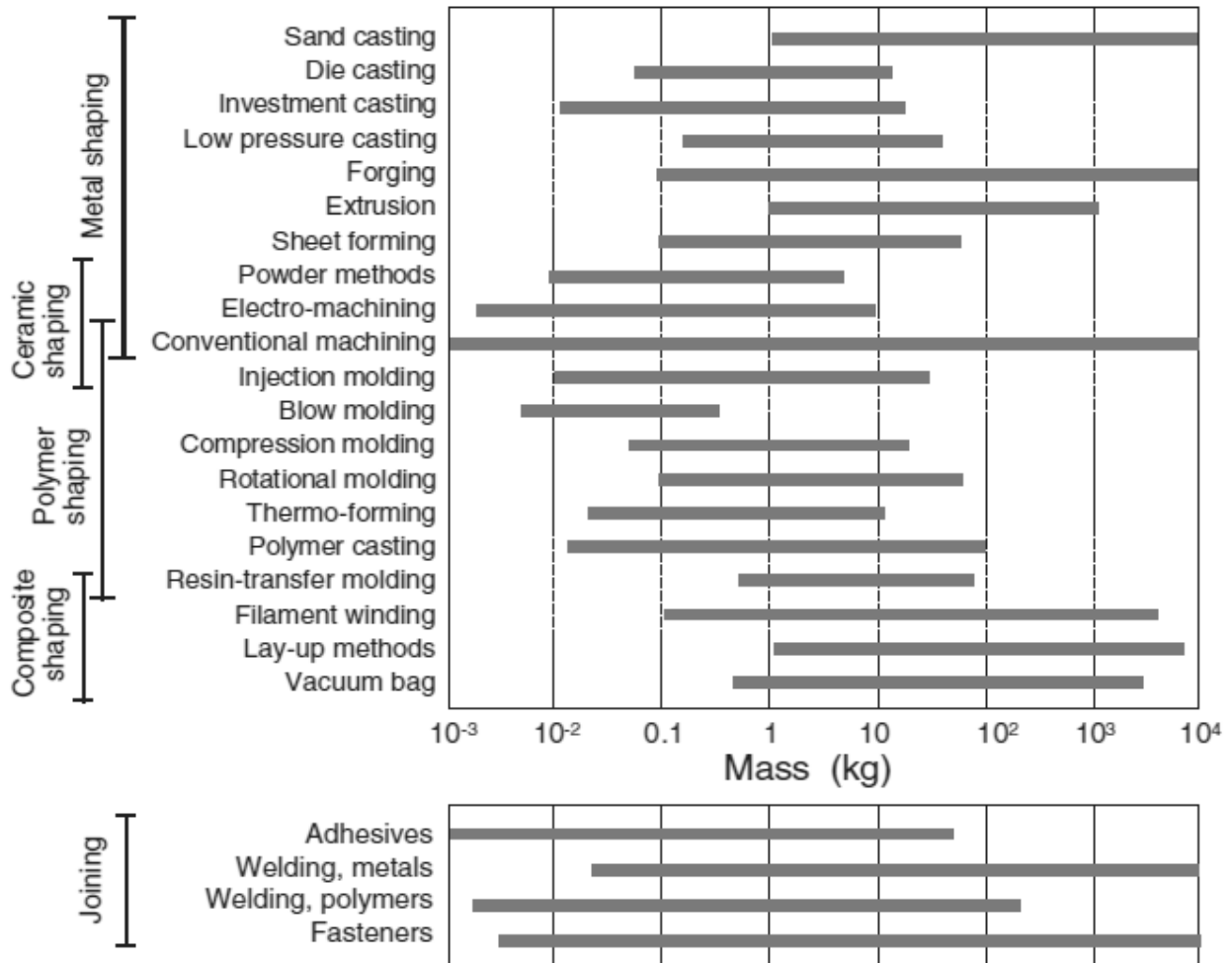

**Figure 1.8** General classification of shapes [2]

		Circular prismatic	Non-circular prismatic	Flat sheet	Dished sheet	3-D solid	3-D hollow
Metal shaping	Sand casting	●	●			●	●
	Die casting	●	●			●	●
	Investment casting	●	●			●	●
	Low pressure casting	●	●			●	●
	Forging	●	●			●	
	Extrusion	●	●				
	Sheet forming	●	●	●	●		
	Powder methods	●	●			●	●
	Electro-machining	●	●	●		●	●
	Conventional machining	●	●	●	●	●	●
Ceramic shaping	Injection molding	●	●			●	●
	Blow molding				●		●
	Compression molding			●	●	●	
	Rotational molding				●		●
	Thermo-forming				●		
Polymer shaping	Polymer casting	●	●			●	●
	Resin-transfer molding	●	●	●	●	●	●
	Filament winding	●	●		●		●
	Lay-up methods			●	●	●	
Composite shaping	Vacuum bag			●	●		

**Figure 1.9** Process–Shape matrix with the dot indicating a compatibility between the shape and the corresponding manufacturing process [2]

**Process-Mass bar-chart:** Figure 1.10 shows the typical mass-range of components that each process can make. Large components can be built up by joining smaller ones. For this reason the ranges associated with joining are shown in the lower part of Figure 1.10. It can be noted IIT BOMBAY that sand casting process, for example, is capable of producing large component while die casting or investment casting processes can make relatively smaller sized parts.

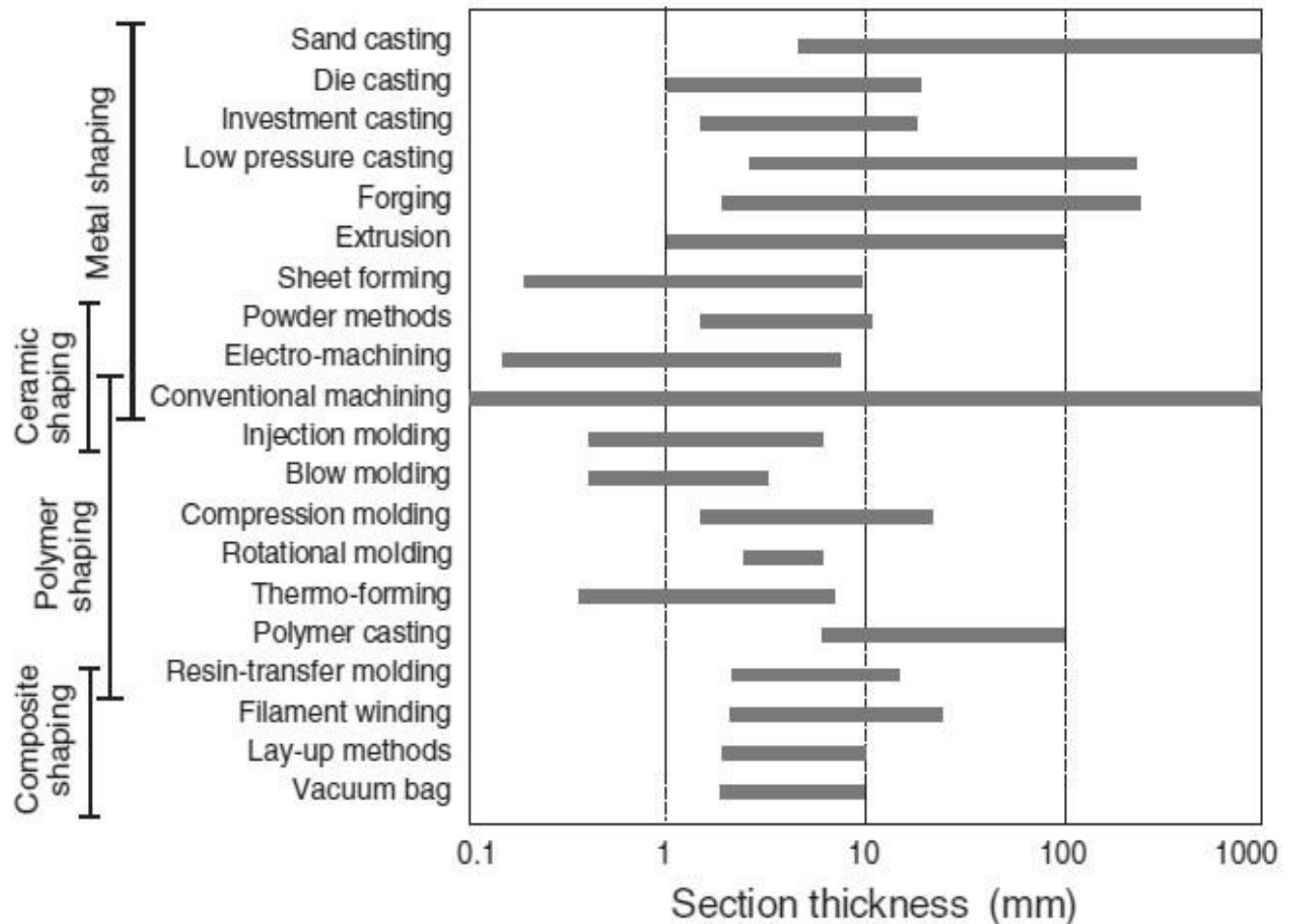

**Figure 1.10** Process–Mass bar chart indicating compatibility between the requisite mass of a part and the corresponding manufacturing process [2]

**Process-Section thickness bar-chart:** The selection of a manufacturing process also depends on the section thickness of the part to be made. Each process has its limit over the range of the section thickness, which it can produce. For example, surface tension and the typical nature of heat flow limit the minimum section and slenderness of gravity-die cast shapes. Bulk deformation processes cover a wider range of section thickness.

Limits on forging pressures also set a lower limit on the section thickness and slenderness that can be forged. Powder forming methods are more limited in the section thicknesses they can create, but they can be used for ceramics and very hard metals that cannot be shaped in other ways. Special techniques such as electro-forming, plasma spraying allow manufacturing of slender shapes. Figure 1.11 depicts the typical manufacturing processes and the range of section thickness that each process can manufacture.

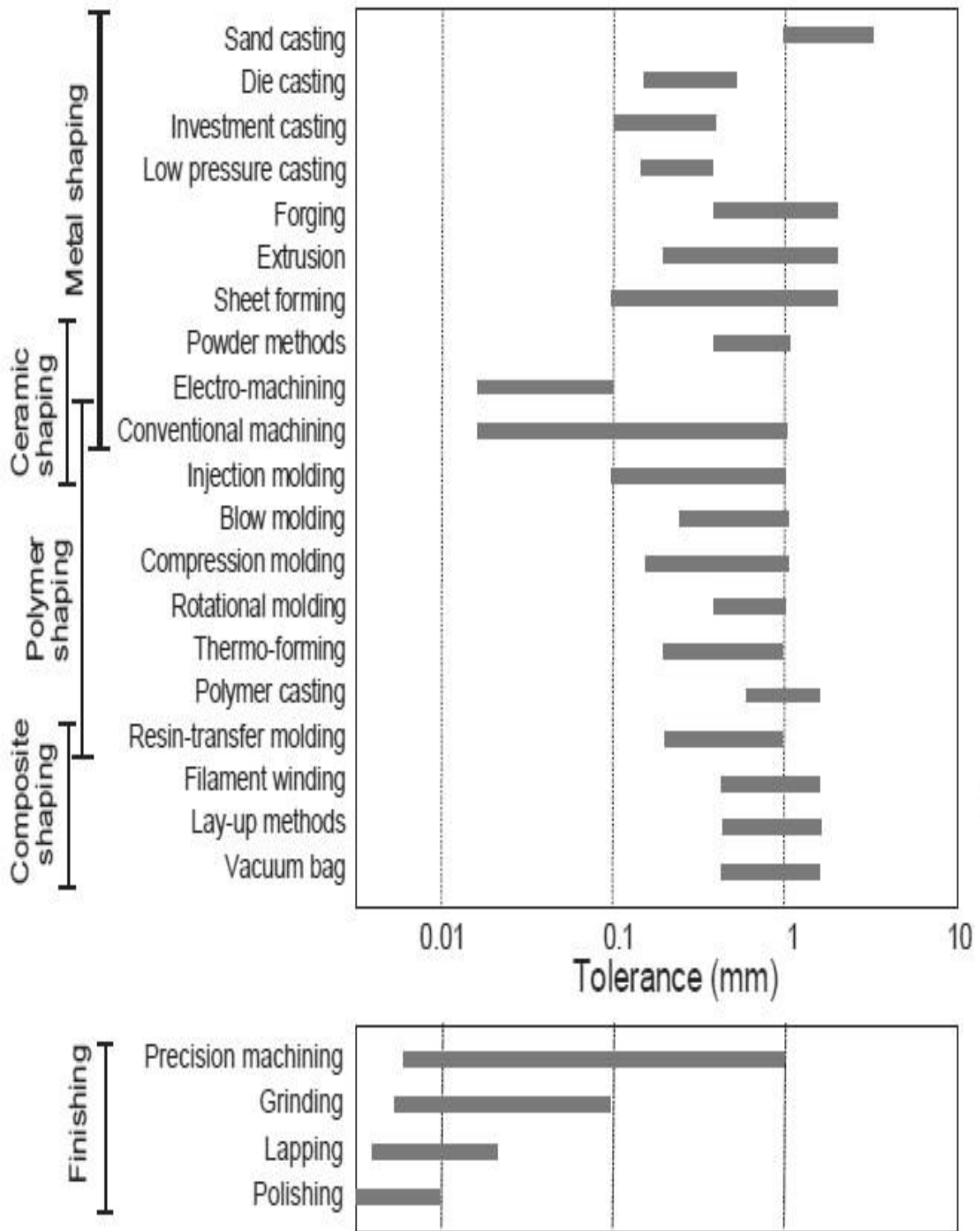



**Figure 1.11** Process–Section thickness bar chart indicating compatibility between the manufacturing process and the range of section thickness that each process can produce [2]

**Process – Dimensional Tolerance bar-charts:** Tolerance and surface roughness that a specific manufacturing process can provide is an important characteristic. Manufacturing processes vary in the levels of tolerance and roughness they can achieve economically. Figures 1.12 and 1.13 shows the process vis-à-vis range of achievable dimensional tolerance and the process vis-à-vis range of minimum achievable surface roughness bar charts, respectively.

For example, die casting process with the permanent metallic dies can give better surface finish compared to the same achievable in sand casting. Machining is capable of delivering high dimensional accuracy and surface finish when the process parameters are controlled properly. Grinding can be adopted to achieve very high tolerance while such precision and finishing operations are generally expensive.



**Figure 1.12** Process – Tolerance Limit bar chart indicating compatibility between the manufacturing process and tolerance limit [2]



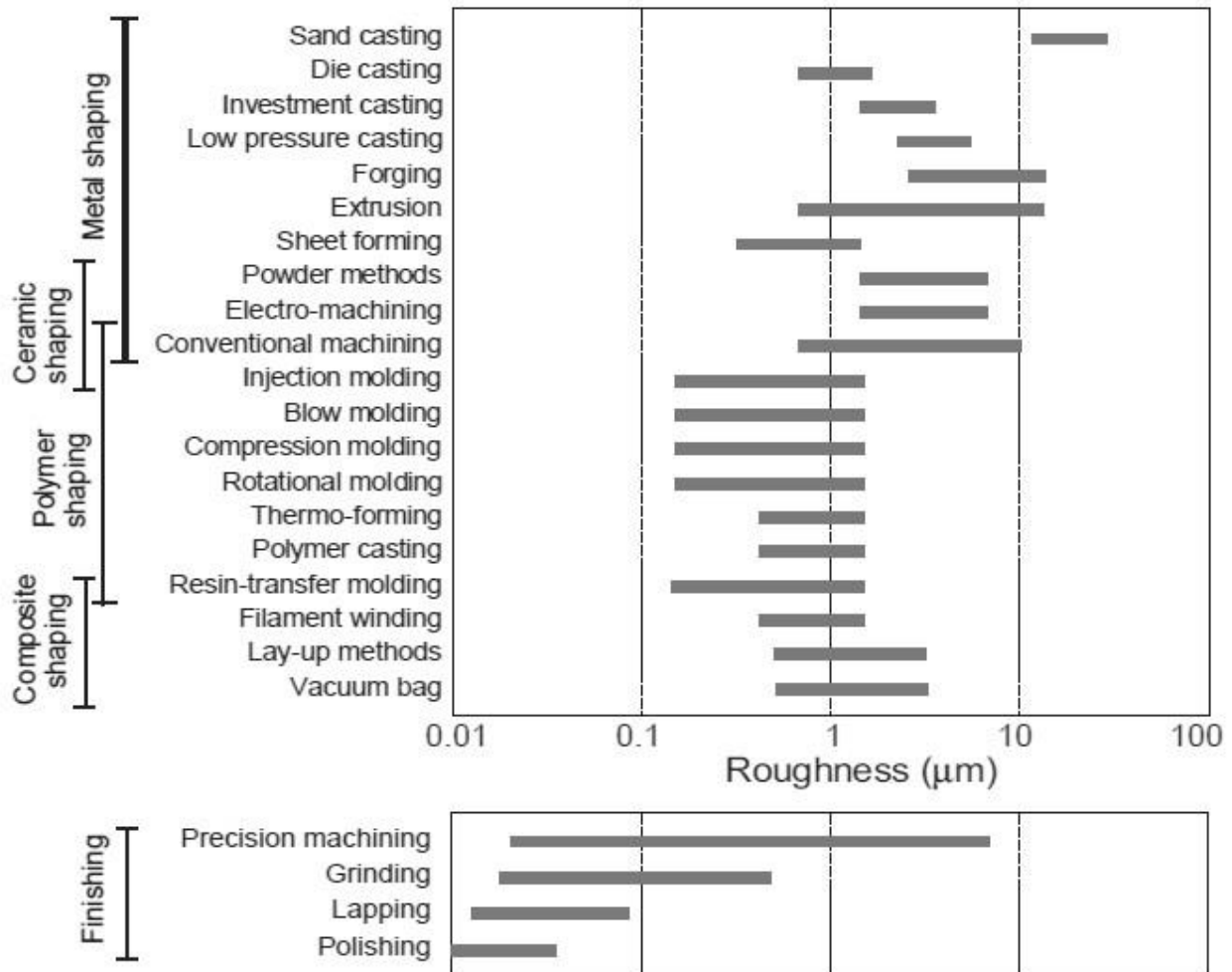

**Figure 1.13** Process – Surface roughness Limit bar chart indicating compatibility between the manufacturing process and minimum surface roughness limit [2]

How to use the process selection charts?

The charts described above provide a quick overview and comparison of the capabilities of various manufacturing processes. However, these charts must be used sufficiently carefully for a given shape, material, dimension, requisite tolerances and surface roughness considering the both the capabilities and limitations of various processes. Often, the major cost associated with a given part lies from the wrong choice of manufacturing process (es). Following are some generic steps which are often followed in the selection of manufacturing process such as:

- keep things standard
- keep things simple
- design the parts so that they are easy to assemble
- do not specify more performance than is needed.

## UNIT – II

### DESIGN FOR MANUFACTURING, CASTING

#### Machining Process:

#### Overview of various Machining Processes:

#### Turning:

Turning is the most important machining process and can produce a wide variety of parts. Primarily, turning is used to produce parts round in shape by a single point cutting tool on lathe machines. The cutting tool is fed either linearly in the direction parallel or perpendicular to the axis of rotation of the work piece, or along a specified path to produce complex rotational shapes. The primary motion of cutting in turning is the rotation of the work piece, and the secondary motion of cutting is the feed motion. Figure 2.1 depicts a typical turning operation in lathe machine. Different types of lathe machines are available today from general purpose to specific job oriented special purpose machines. In general, turning refers to a class of processes carried out on a lathe machine. A brief outline of some the sub-class of turning processes are presented below

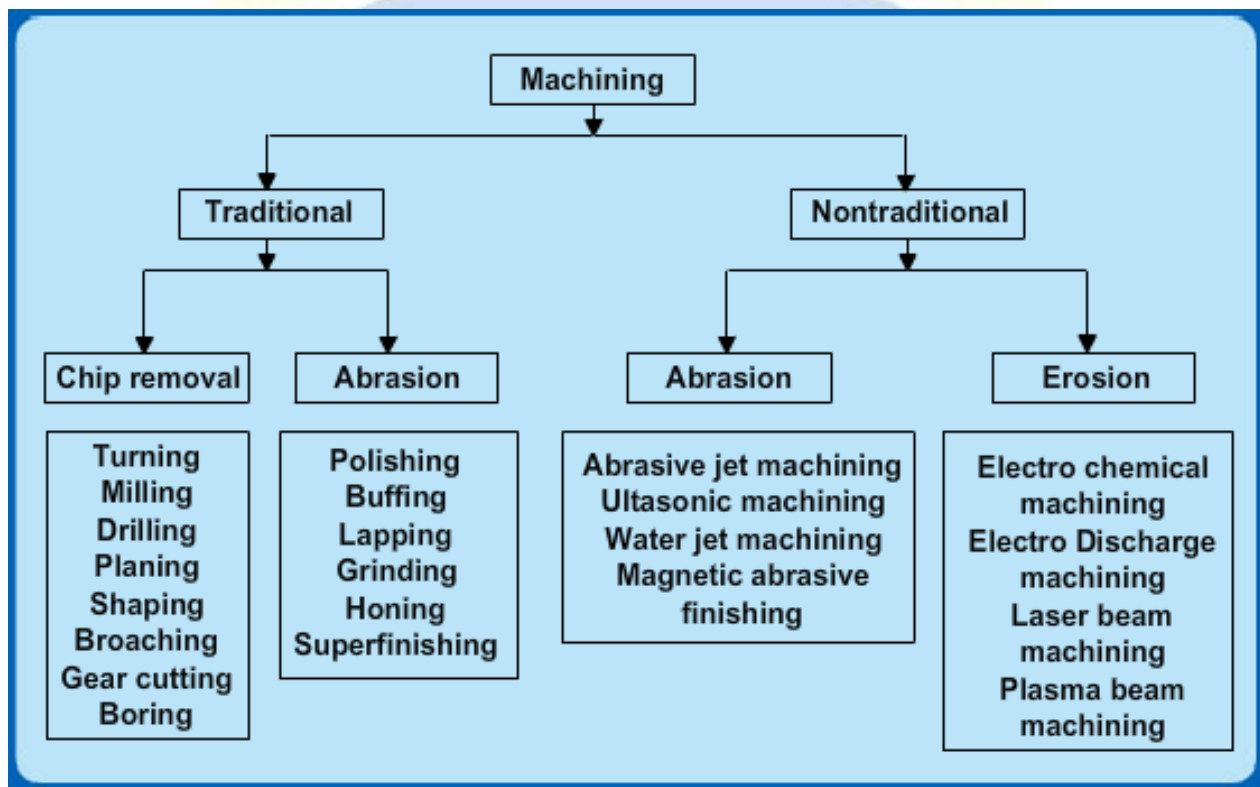
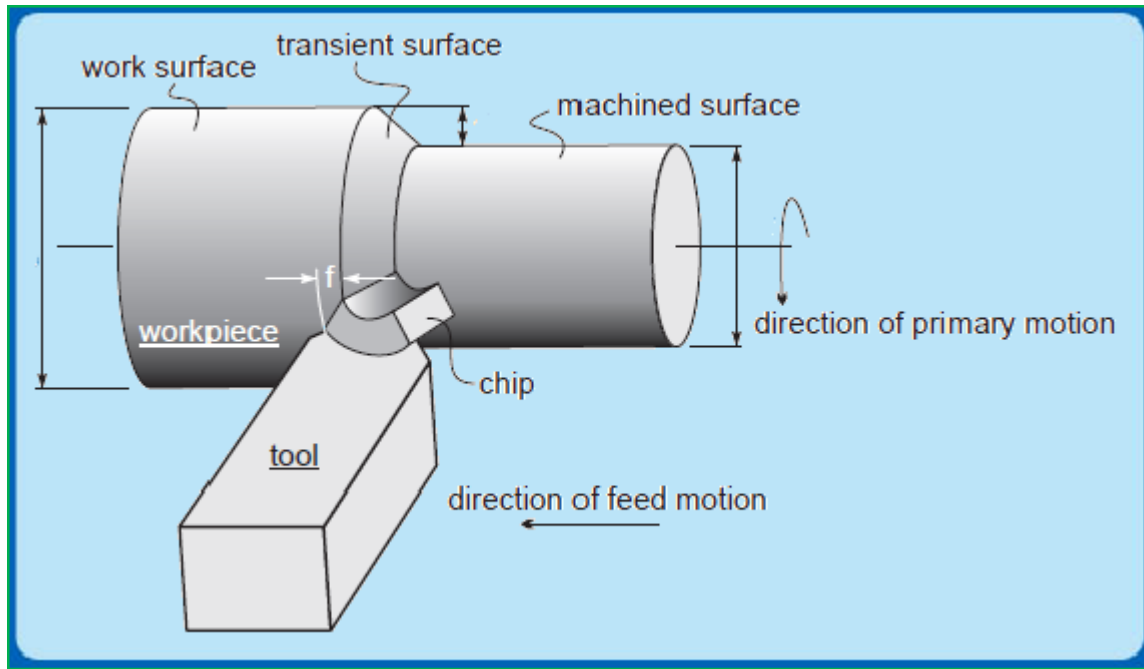

Figure 2.1 Classification of Machining Processes



**Figure 2.3 Schematic depiction of turning operation**

**Straight turning** is used to reduce the diameter of a part to a desired dimension (Figure 2.3 a). The resulting machined surface is cylindrical.

**Contour turning and Taper turning** (Figure 2.3b) are performed by employing a complex feed motion using special attachments to a *single point turning tool* thus creating a contoured shape on the work piece.

**Facing** (Figure 2.3c) is done to create a smooth, flat face perpendicular to the axis of a cylindrical part in an accurate manner. The tool is fed radially or axially to create a flat machined surface.

**Thread cutting** (Figure 2.3d) is possible in *lathe machine* by advancing the cutting tool at a feed exactly equal to the *thread pitch*.

The **single-point cutting tool** cuts in a helical band, which is actually a thread. The tool point must be ground so that it has the same profile as the thread to be cut. Thread can be both external and internal types. In **form turning** (Figure 2.3e), the shape of the cutting tool is imparted to the work piece by plunging the tool into the work piece.

In **form turning**, the cutting tool can be very complex and expensive but the feed will remain linear and will not require special machine tools or devices. **Boring** (Figure 2.3f) is similar to **straight turning** operation but differs in the fact that it can produce internal surface of revolution, which is often considered to be difficult due to overhanging condition of the tool.

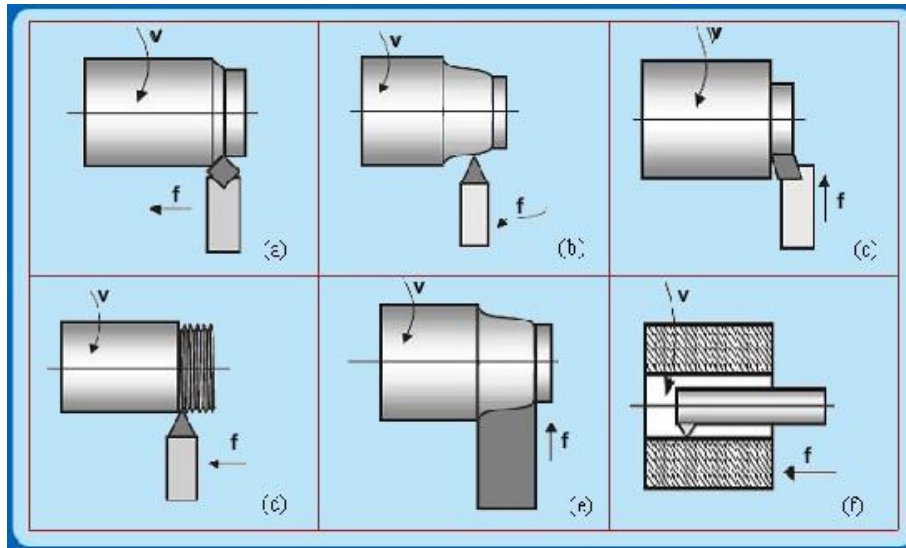

**Figure 2.3 Different types of Turning Operations**

**Straight turning** is used to reduce the diameter of a part to a desired dimension (Figure 2.3a). The resulting machined surface is cylindrical. **Contour turning and Taper turning** (Figure 2.3b) are performed by employing a complex.

### **Milling:**

Milling is a process of producing flat and complex shapes with the use of multi-point (or multi-tooth) cutting tool. The axis of rotation of the cutting tool is perpendicular to the direction of feed, either parallel or perpendicular to the machined surface.

Milling is usually an interrupted cutting operation since the teeth of the milling cutter enter and exit the work piece during each revolution. This interrupted cutting action subjects the teeth to a cycle of impact force and thermal shock on every rotation. The tool material and cutter geometry must be designed to withstand these conditions. Figure 2.5 depicts two basic types of milling operations: down milling, when the cutter rotation is in the same direction as the motion of the work piece being fed, and up milling, in which the work piece is moving towards the cutter, opposing the cutter direction of rotation.

In down milling, the cutting force is directed on to the work table, which allows thinner parts to be machined without susceptibility to breakage. Better surface finish is obtained in down milling but the stress load on the teeth is abrupt, which may damage the cutter. Backlash eliminator has to be used in this operation. In up milling, the cutting action tends to lift the work piece and hence, Proper fixture is required in this operation.

MECHANICAL



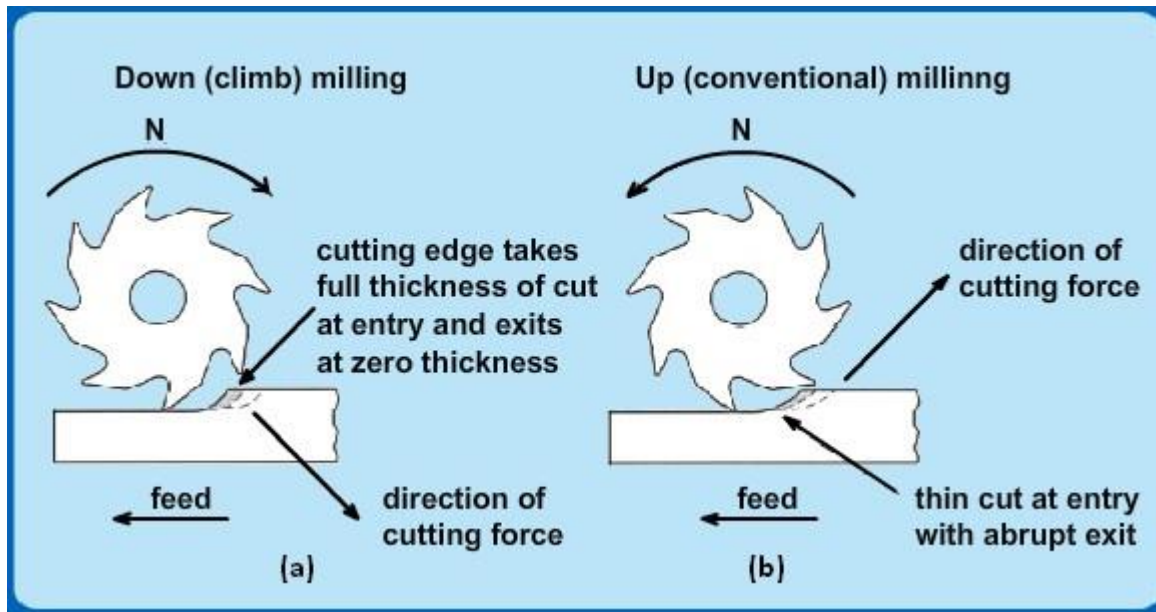

**Figure 2.4 Schematic depiction of down milling (a) and up milling (b) operations**

Depending on the orientation and geometry of the milling tool, several varieties of milling operations are possible. In *peripheral milling* (Figure 2.5a), also referred to as *plain milling*, the axis of the cutter is parallel to the surface being machined, and the operation is performed by the cutting edges on the outside periphery of the tool.

The primary motion is the rotation of the tool. The feed is imparted to the work piece. In *face milling* (Figure 2.5b), the tool is perpendicular to the machined surface. The tool axis is vertical, and machining is performed by the teeth on both the end and the periphery of the face-milling tool. Also, up and down types of milling are available, depending on directions of the tool

rotation and feed. *End milling* is used to produce pockets, key holes by using a tool referred to as the *end mill*, has a diameter less than the work piece width. In *form milling* (Figure 2.5c), the cutting edges of the peripheral tool (also referred to as *form cutter*) have a special profile that is imparted to the work piece.

Tools with various profiles are also available to cut different two-dimensional surfaces. One important application of form milling is in gear manufacturing.

*Surface contouring* (Figure 2.5d), is an operation performed by computer controlled milling machines in which a ball-end mill is fed back and forth across the work piece along a curvilinear path at close intervals to produce complex three-dimensional surfaces.

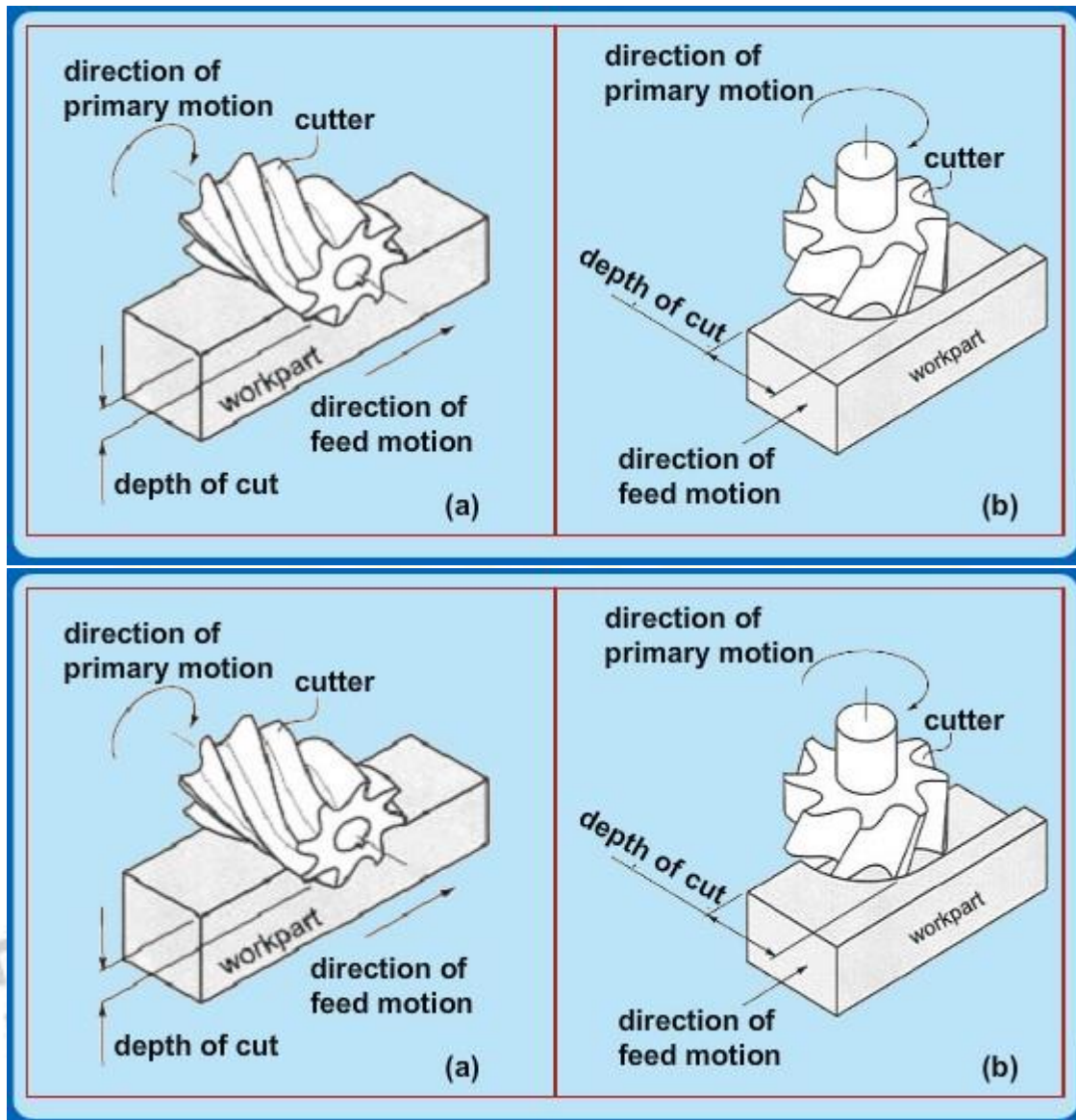

**Figure 2.5 Different types of milling operations**

### **Drilling:**

Drilling is a process of producing round holes in a solid material or enlarging existing holes with the use of multi-point cutting tools called drills or drill bits. Various cutting tools are available for drilling, but the most common is the twist drill. A variety of drilling processes (Figure 2.6) are available to serve different purposes. Drilling is used to drill a round blind or through hole in a solid material. If the hole is larger than ~30 mm, a smaller pilot hole is drilled before core drilling the final one. For holes larger than ~50 mm, three-step drilling is recommended. Core drilling is used to increase the diameter of an existing hole. Step drilling is used to drill a stepped (multi-diameter) hole in a solid material. Counter boring provides a stepped hole again but with flat and perpendicular relative to hole axis face. The hole is used to seat internal hexagonal bolt heads. Countersinking is similar to counter boring, except that the step is conical for flat head screws.

Reaming operation is usually meant to slightly increase the size and to provide a better tolerance and surface finish of an initially drilled hole. The tool is called reamer. Center drilling is used to drill a starting hole to precisely define the location for subsequent drilling operation.

The tool is called center drill that has a thick shaft and very short flutes. Gun drilling is a specific operation to drill holes with very large length-to-diameter ratio up to 300. There are several modifications of this operation but in all cases cutting fluid is delivered directly to the cutting zone internally through the drill to cool and lubricate the cutting edges, and to remove the chips.

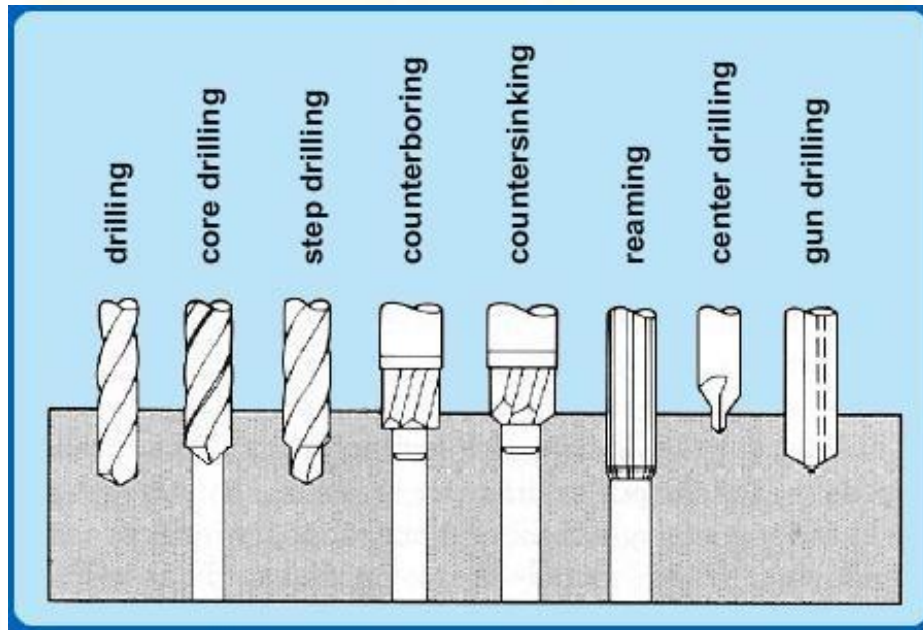

Figure 2.6 Different Types of Drilling Operations

### Planing , Shaping and Broaching:

Planing and shaping (Figure 2.7) are similar operations, which differ only in the kinematics of the process.

Planing is a machining operation in which the primary cutting motion is performed by the work piece and feed motion is imparted to the cutting tool. In shaping, the primary motion is performed by the tool, and feed by the work piece.



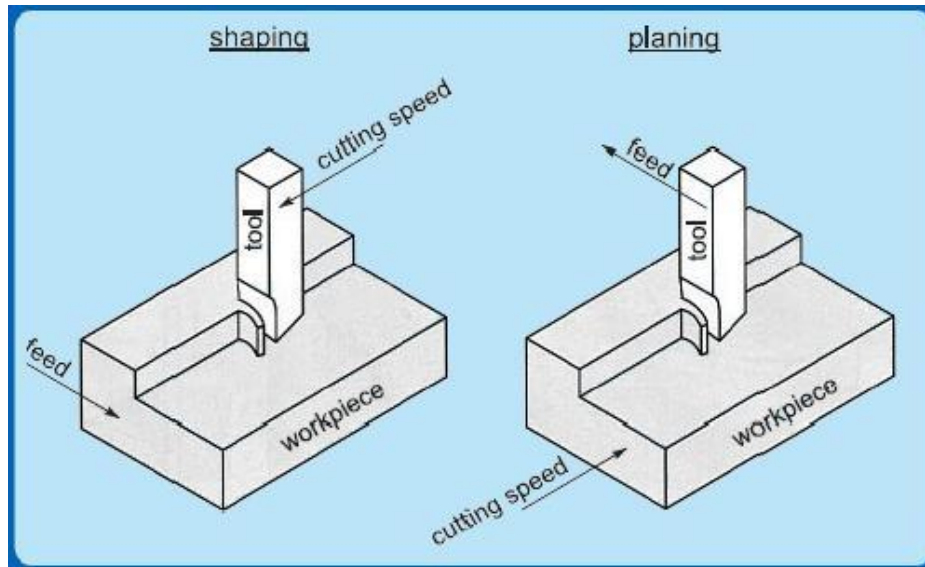

Figure 2.7 Kinematics of shaping and planing

**Broaching** is a machining operation that involves the linear movement of a multi-point cutting tool (referred to as *broach*) relative to the work piece in the direction of the tool axis. The shape of the machined surface is determined by the contour of the final cutting edges on the *broach*.

*Broaching* is a highly productive method of machining with advantages like good surface finish, close tolerances, and the variety of possible machined surface shapes some of them can only be produced by *broaching*. Owing to the complicated geometry of the *broach*, the tooling is expensive. The broaching tools cannot be reground and have to be replaced when wear becomes excessive. *Broaching* is a typical mass production operation.

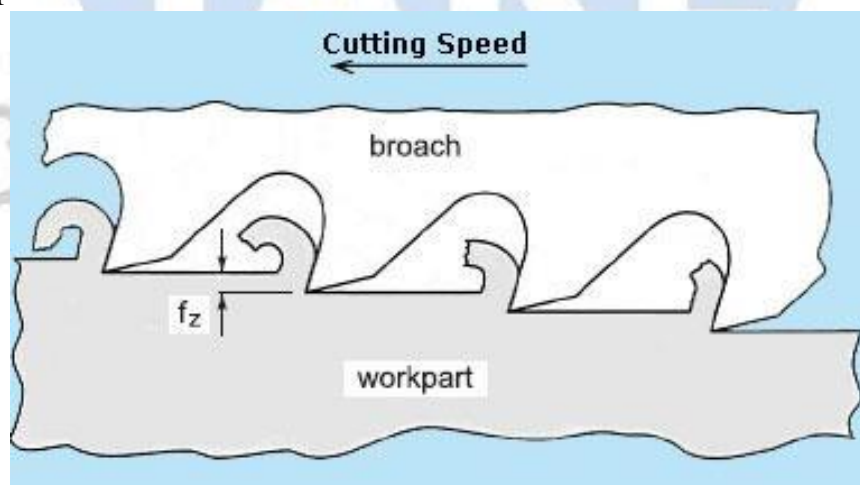

Figure 2.8 Schematic of broaching operation [1]

### Grinding:

Grinding (Figure 2.9) is the most popular form of abrasive machining. It involves an abrasive tools consisting of grain of hard materials which are forced to rub against the work piece removing a very

small amount of material. Due to the random orientation of grains and some uncontrollable cutting condition, the selection of proper parameters often becomes difficult. Grinding can be performed to produce flat as well as cylindrical (both external and internal) surface efficiently. Grinding is applied when the material is too hard to be machined economically or when tolerances required are very tight.

Grinding can produce flatness tolerances of less than  $\pm 0.0025$  mm ( $\pm 0.0001$  in) on a 127 x 127 mm (5 x 5 in) steel surface if the surface is adequately supported. In recent times, enormous amount of research work has made grinding process very economical and efficient for removing a large thickness of material also. The major advantages of grinding process include dimensional accuracy, good surface finish, good form and locational accuracy applicable to both hardened and unhardened material.

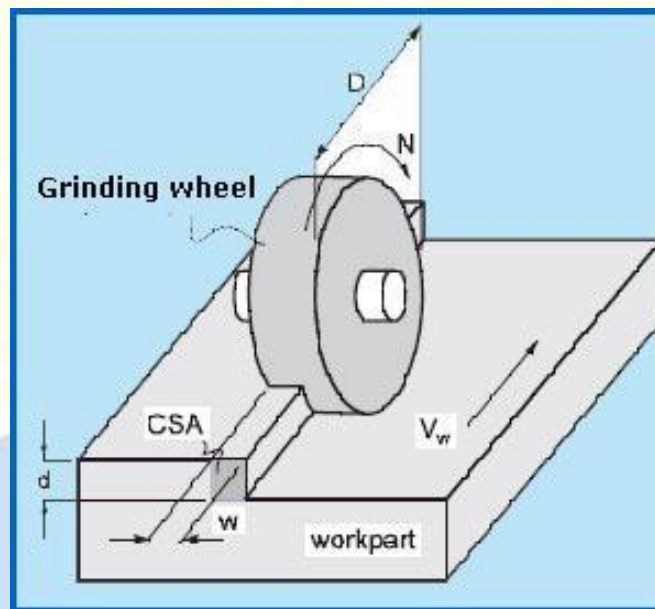

Figure 2.9 Schematic of grinding operation

### **Abrasive Finishing:**

As the name indicates, these groups of operations are used to achieve superior surface finish up to mirror-like finishing and very close dimensional precision. The finishing operations are assigned as the last operations in typical single part production cycle usually after the conventional or abrasive machining operations. Honing, Lapping, Super finishing, Polishing process comes under this group. Figure 2.10 depicts a comparison of surface roughness values for different processes.

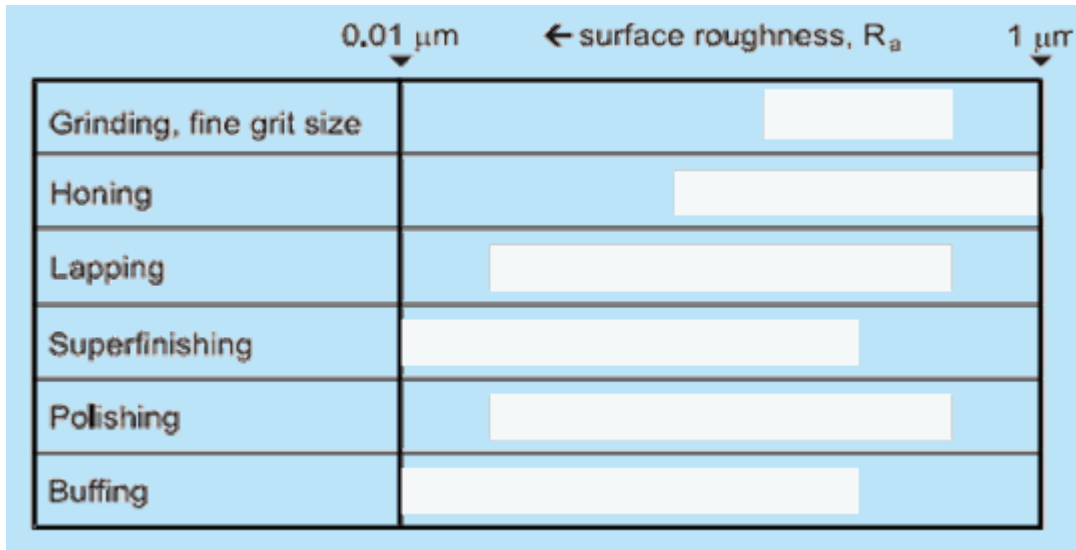

Figure 2.10 Comparison of surface roughness

### Non Traditional Machining Processes:

To distinguish the non-traditional machining (NTM) processes from the traditional or conventional ones, it is necessary to understand the differences and the similar characteristics between conventional machining processes and NTM processes.

The conventional processes generally involve a wedge shaped cutting tool to remove material in the form of chip by causing plastic deformation and shear failure. The cutting tool has to be harder than the work piece at room temperature as well as under machining conditions. However, the non-traditional processes commonly embody by the following characteristics:

Material removal may occur with or without the conventional chip formation, A physical cutting tool may not always be present [e.g. a typical laser beam is used for machining in laser jet machining process. The tool material needs not be harder than the work piece material. Majority of the non-traditional machining processes do not necessarily use mechanical energy and rather different other forms of energy for material removal.

Some commonly used non-traditional machining processes are described below.

:

#### Abrasive Jet Machining:

Abrasive jet machining (Figure 2.11) process involves impinging of fine abrasive particles on the work material at a very high velocity causing small fracture on the workpiece surface on impact. A gas stream carries both the abrasive particles and the fractured particles away. The jet velocity is in the range of 150-

300 m/s and the applied pressure can range from two to ten times of atmospheric pressure. Abrasive Jet Machining (AJM) is used for deburring, etching, and cleaning of hard and brittle metals, alloys, and nonmetallic materials.

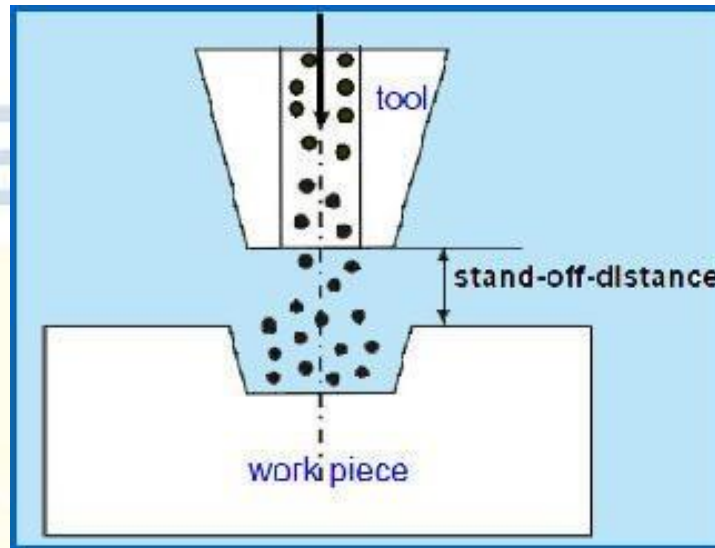

Figure 2.11 Schematic depiction of Abrasive Jet Machining

### Ultrasonic Machining:

In ultrasonic machining (Figure 2.12), a tool of desired shape vibrates at an ultrasonic frequency (19 ~ 25 kHz) with an amplitude of around 15 – 50  $\mu\text{m}$  over the work piece. The tool is pressed downward with a feed force and the machining zone is flooded with hard abrasive particles generally in the form of water based slurry. As the tool vibrates at ultrasonic frequency, the abrasive particle removes material by indentation. This process can be used for very accurate machining of hard and brittle metallic alloys, semiconductors, glass, ceramics, carbides, wire drawing and punching dies, etc.

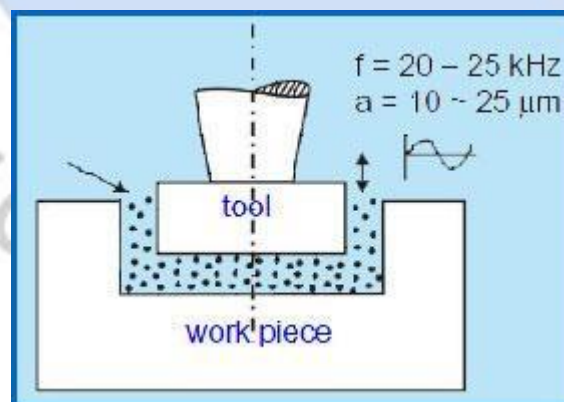

Figure 2.12 Schematic depiction of Ultrasonic Machining



### Water Jet and Abrasive Water Jet Machining:

Water Jet Machining uses a fine, high-pressure, high velocity (faster than the speed of sound) stream of water directed at the work surface to cause material removal. The cutting ability of water jet machining can be improved drastically by adding hard and sharp abrasive particles into the water jet and is termed as Abrasive Water Jet machining. This jet is sprayed over the work surface with very high pressure causing removal of material by the indentation action. Typical application of these processes includes paint removal, cleaning and cutting of sheets especially of softer materials, cutting of frozen meat, dismantling of nuclear plant parts, etc.

### Electro Chemical Machining:

Electro chemical machining (Figure 2.13) can be thought of a controlled anodic dissolution at atomic level of an electrically conductive work piece due to the flow of high current at relatively low potential difference. The machining process is attained by a shaped tool. Both the work piece and the tool are submerged into a suitable electrolyte which is often the water based neutral salt solution. In principle, it can be considered to be opposite of electrochemical coating process. As the tool does not contact the work piece, there is no need to use expensive alloys to make the tool tougher or harder than the work piece, which is a distinct advantage. There is less tool wear, and less heat and stresses are produced during this process. High tooling costs and risk of corrosion due to electrolyte are some disadvantages of this process.

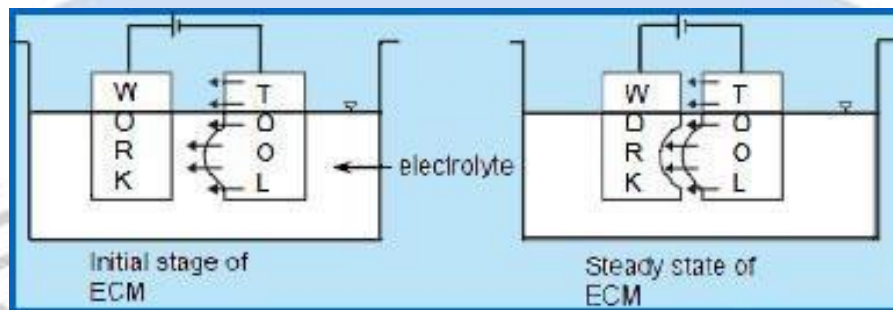

Figure 2.13 Schematic outline of Electro Chemical Machining

### Electro Discharge Machining:

Electro Discharge Machining (EDM) (Figure 2.14) is an electro-thermal non-traditional machining process, where electrical energy is used to generate electrical spark between the tool and the work piece. The material removal occurs primarily by vaporization of work piece material due to high thermal energy of the spark. Electro-discharge machining is mainly used to machine difficult-to-machine materials and high strength and temperature resistant alloys. Difficult geometries in small batches or even on job-shop basis can be produced using this process. The only important point is that the work piece material has to be electrically conductive. Some of the major advantages of this process are as follows:

Complex shapes that are difficult to machine with conventional processes, can be done easily by electro discharge machining process,

Extremely hard material can be machined to close tolerances, Very small work pieces can be handled with sufficient ease, and A good surface finish can be obtained. When the tool in electro discharge machining process is replaced by a continuously moving small diameter electrically conducting wire, the same is referred to as wire- electro discharge machining process that is widely used to cut a narrow kerf in the work piece.

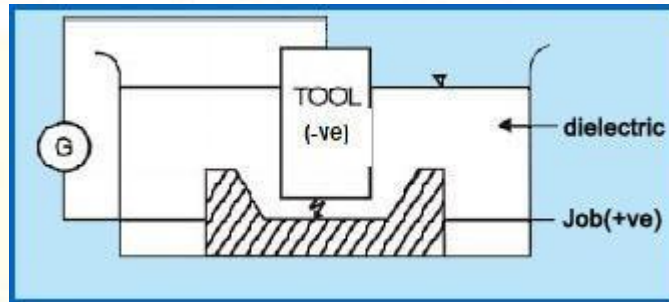

Figure 2.14 Schematic depiction of Electro discharge Machining

### **Laser and Electron Beam Machining :**

Laser beam machining (LBM) (Figure 2.15a) uses the light energy from a laser to remove material by vaporization and ablation whereas electron beam machining (EBM) uses a high-velocity stream of electrons focused on the work piece surface to remove material by melting and vaporization. The schematic of these processes are shown in the Figure 2.15.

The types of lasers used in laser beam machining process include carbon dioxide (CO<sub>2</sub>) gas lasers, solid lasers (Nd-YAG), fiber lasers and eximer lasers (especially for micro-level machining) although the CO<sub>2</sub> based gas lasers are primarily used for machining. The light produced by the laser has significantly less power than a normal white light, but it can be focused optically to deliver a very high density source and when irradiated on a surface can result in melting and vaporization of workpiece material in a very localized area causing material removal.

In electron beam machining (Figure 2.15b) process, the electron beam gun generates a continuous stream of electrons that are focused through an electromagnetic lens on the work surface. The electrons are accelerated with voltages of approximately 1,50,000 V to create electron velocities over 200,000 km/s. On impinging the surface, the kinetic energy of the electrons is converted into thermal energy of extremely high density, which vaporizes the material in a much localized area. Electron beam machining must be carried out in a vacuum chamber to eliminate collision of the electrons with gas molecules.

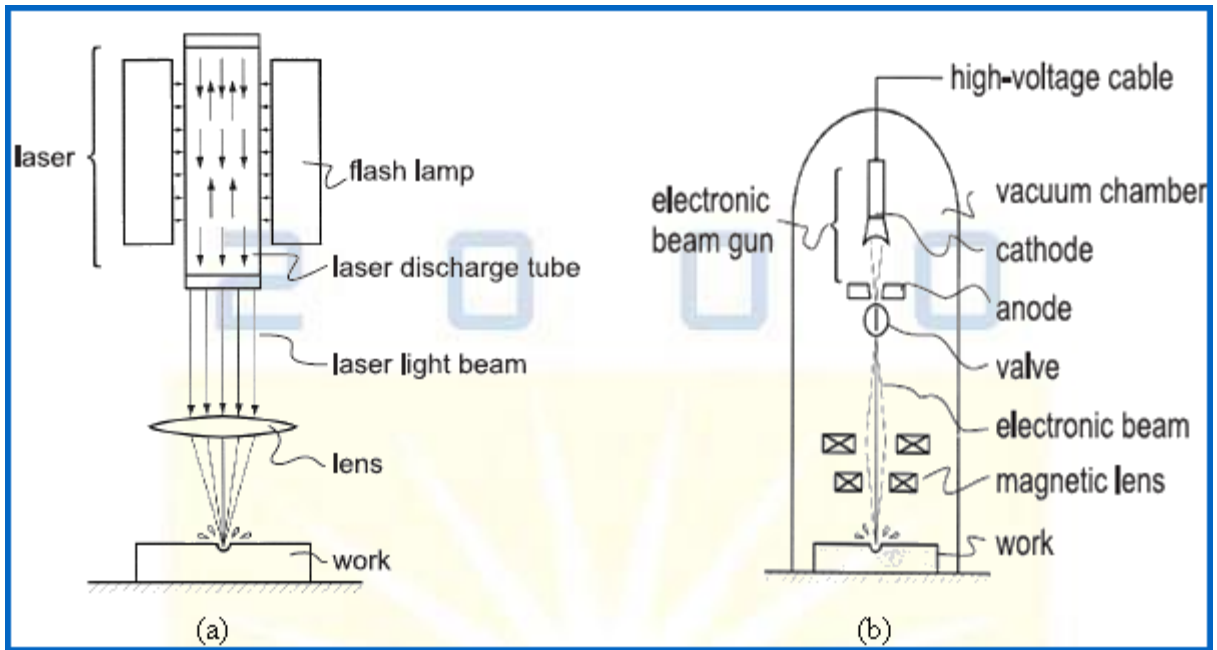

Figure 2.15 Schematic depiction of (a) Laser beam, and (b) Electron beam machining

## Design for Machining

### Machinability:

It is clear from the previous descriptions that there are a numbers of different machining processes available to meet the needs like dimensional accuracy, surface finish, ease of machining of a material etc. Depending of these factors, the proper process is chosen to meet the objective. It is always attempted to accomplish the machining effectively, efficiently and economically as far as possible by removing the excess material smoothly and speedily with lower power consumption, tool wear and surface deterioration. The term machinability is used for grading work material with respect to the machining characteristics. There is no proper definition of machinability and often it is referred to

- The ability of the work material to be machined,
- How easily and fast a material can be machined, and
- Material response to machining.

A material is said to be more machinable if it results in lesser tool wear, greater tool life and provide better surface finish consuming lesser power. Attempts are made to measure or quantify the machinability in terms of (a) tool life which substantially influences productivity and economy in machining, (b) magnitude of cutting forces which affects power consumption and dimensional accuracy, and (c) surface finish, which plays role on performance and service life of the product. For example, cast iron is often considered more machinable than aluminum. Cast iron contains graphite flakes which causes failure easily by stress concentration. It also acts as a lubricant reducing the extent of heat generation and friction which finally leads to less tool wear. On the other hand, aluminium, being a



ductile material, produces continuous chips and undergo severe plastic deformation prior to complete detachment. These not only create operational problems but also increase the cutting force. In practical it is not possible to quantify all the criteria that affect machinability. Application of cutting fluid also improve machinability by

- Improving tool life by cooling and lubrication,
- Reducing cutting forces and specific energy consumption, and
- Improving surface integrity by cooling, lubricating and cleaning at the cutting zone.
- Selection of Machining Parameters

Selection of the proper parameters is one of the major considerations during machining. A typical machining process depends on a numbers of factors. It is not possible to consider all factors together. Lots of research works have revealed the most important factors to be considered and controlled properly to achieve most efficient machining. Cutting speed, feed and depth of cut are the three most important factors to be considered to maximize production rate and minimize overall cost. To maximize the production rate, the total production time has to be minimized. The total time per unit product for operation is given by:

$$T_C = T_h + T_m + \frac{T_t}{n_p} \quad (1)$$

where  $T_h$  is part handling time,  $T_m$  is the machining time per part, is the tool change time per part , and  $n_p$  is the number of pieces cut in one tool life. Similarly, the cost per unit is given by

$$C_C = C_0 T_h + C_0 T_m + C_0 \frac{T_t}{n_p} + \frac{C_t}{n_p} \quad (2)$$

### Optimizing Cutting Speed:

Cutting speed is the major factor to be controlled during machining as it not only determines the production rate but also the tool life. Higher cutting speed leads to higher productivity but its upper value is limited by the tool life, given by the Taylor tool life equation (eq. 3) as:

$$VT^n = C \quad (3)$$

where  $V$  is the cutting speed in m/min,  $T$  is the tool life in min, and  $C$  and  $n$  are material constants. The term  $n$  is is also referred to as the Taylor exponent. The cutting speed has to be selected to achieve a balance between high metal removal rate and suitably longer tool life. Various mathematical formulations are available for optimal cutting speed. A typical variation of machining cycle time and unit cost with cutting speed is shown in the Figure 3.5.16 and 3.5.17, respectively.

## Optimizing Depth of Cut and Feed:

Depth of cut and feed also affect the machining efficiency to a lesser extent than the cutting speed. Depth of cut is often predetermined by the workpiece geometry and the operation sequences. In roughing, the depth of cut is made as large as possible to maximize the material removal rate, subject to limitations of available power, machine tool and setup rigidity, and strength of cutting tool. In finishing, the depth of cut is set to achieve final part dimensions. The feed rate generally depends on the following factors:

1. *Tooling* – harder tool materials require lower feeds
2. *Roughing or finishing* - Roughing means high feeds, finishing means low feeds
3. *Constraints on feed in roughing* - Limits imposed by cutting forces, setup rigidity, and sometimes machine power
4. *Surface finish requirements in finishing* – select feed to produce desired finish

Equation (4) depicts the modified Taylor's tool life equation given as

$$V^x f^y t^z = \frac{C}{T} \quad (4)$$

where  $V$  is the cutting speed in m/min,  $T$  is the tool life in min,  $f$  is the feed in mm/rev,  $t$  is the depth of cut in mm, and  $C$ ,  $x$ ,  $y$  and  $z$  are material constants. The terms  $x$ ,  $y$ , and  $z$  are also referred to as the modified Taylor exponents.

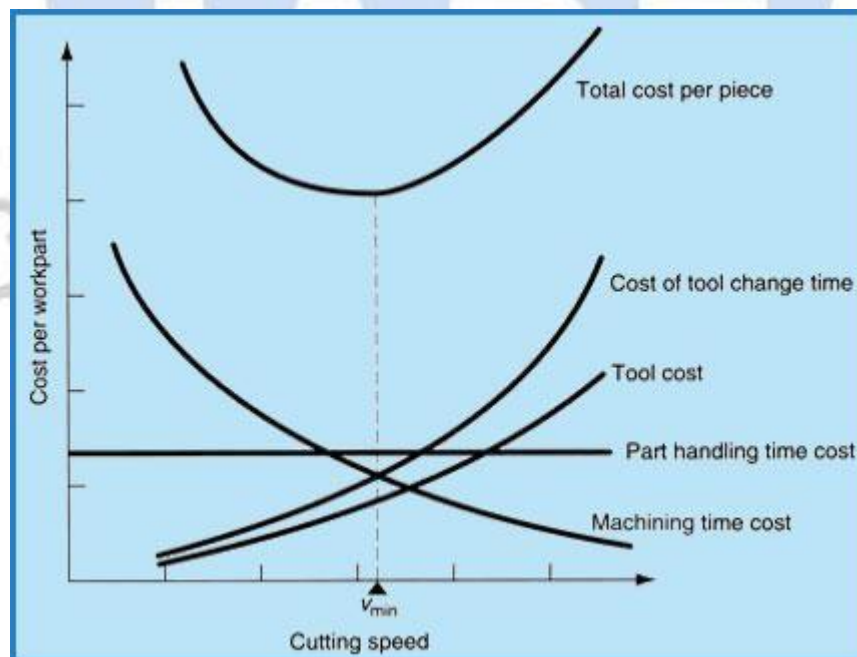

Figure 2.16 Machining cycle time vis-a-vis cutting speed

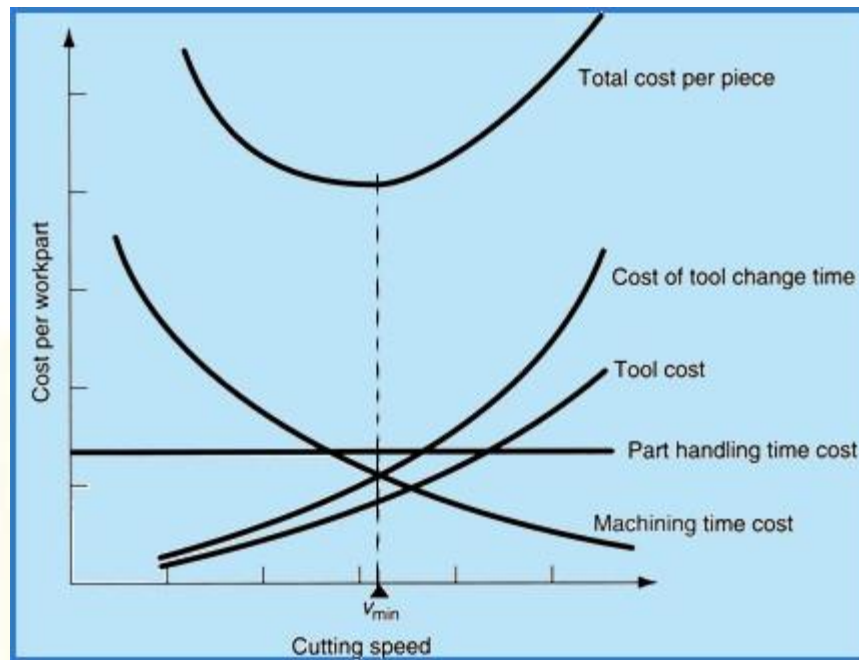

Figure 2.17 Unit cost vis-a-vis cutting speed

#### Guide Lines for Designing Parts

1. Machined features such as sharp corners, edges, and points should be avoided because they are difficult to machine, creates burrs and are dangerous to handle, causes stress concentration.
2. Machined parts should be designed so they can be produced from standard stock sizes
3. Select materials with good machinability.
4. Design machined parts with features that can be produced in a minimum number of setups (Figure 2.17).

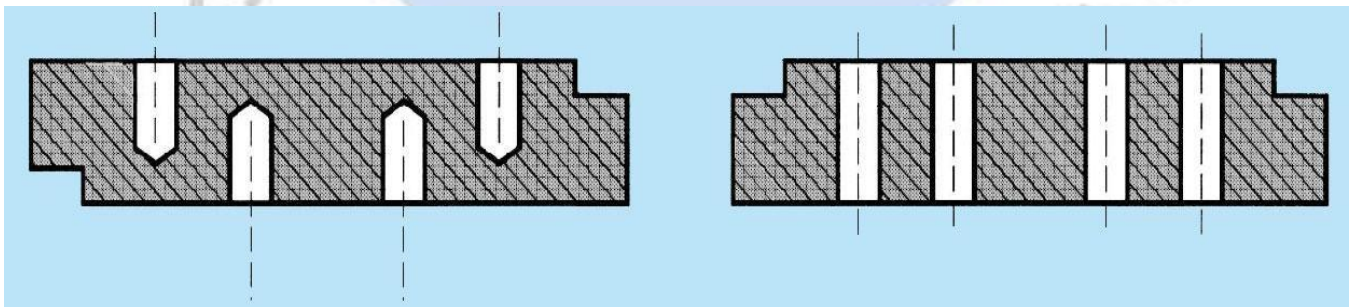

Figure 3.5.18 Through holes need less number of setup

5. Machined parts should be designed with features that can be achieved with standard cutting tools.
6. Avoid unusual hole sizes, threads, and features requiring special form tools.
7. Design parts so that number of individual cutting tools needed is minimized.
8. Reduce volume of material to be removed thus reducing machining time.

9. Use large tolerances and surface roughness that will allow higher material removal rate or avoid finish cut.
10. Reduce surface area to be machined.
11. Reduce tool path length e.g. milling pockets larger radius allows larger diameter end mill and shorter path length. More rigid tool also allows higher feed rate in milling.
12. Design the part in such a way that reduces setup, reorientation time thus reducing total operation time (Figure 2.18).
13. Minimize the use of different machine for a single part. Use single machine as far as possible (Figure 2.19).

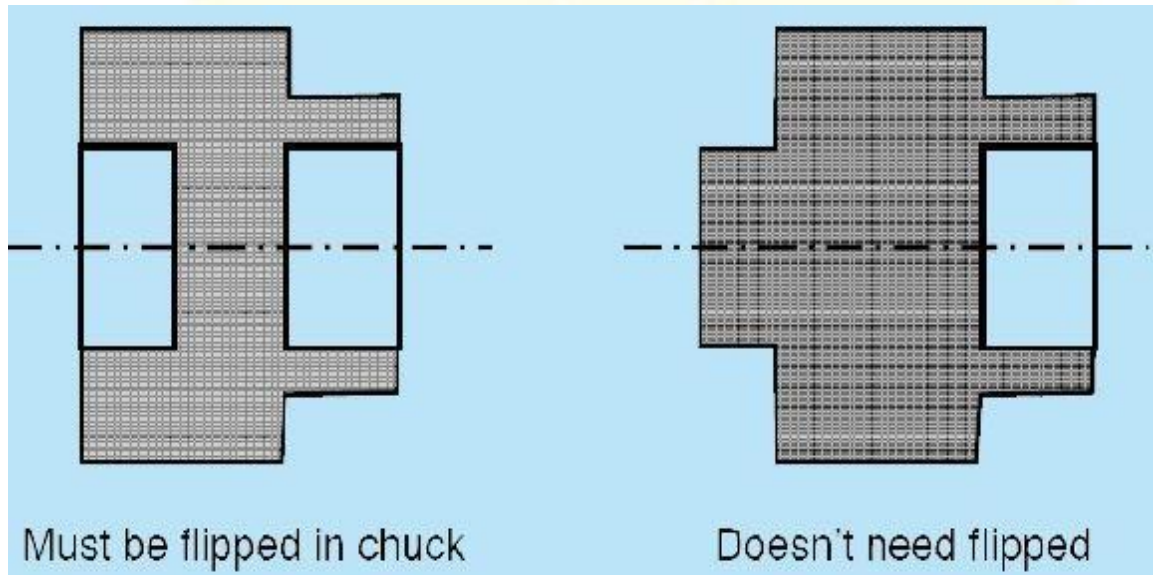

Figure 2.19 Avoid need to re-clamp

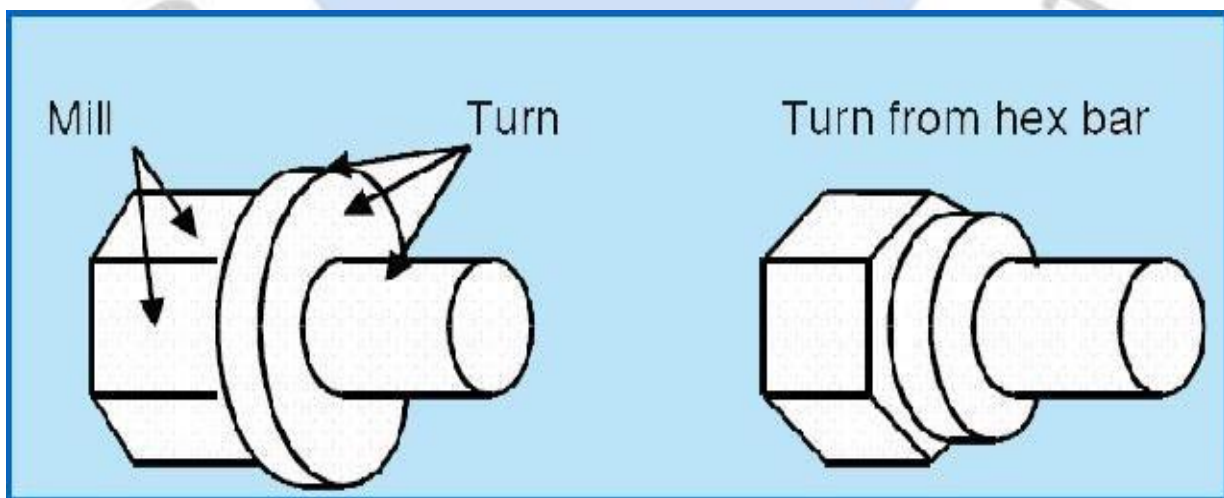

Figure 2.20 Using Single machine



## UNIT III

### DESIGN FOR JOINING, FORMING

#### Appraisal of various casting processes :

Minimum distance between raw material and product

Pouring molten metal into mould cavity and after solidification The metal assumes shape o mould cavity product is called casting

1. Sand casting
2. Shell moulding
3. Ceramic shell casting
4. Investment casting
5. Centrifugal casting
6. Permanent mould casting
7. Gravity die casting
8. Low pressure die casting
9. Hot chamber die casting
10. Cold chamber die casting

#### DESIGN Considerations for Casting:

1. Pattern allowances : Free withdrawal of pattern : Draft on the vertical faces of casting based on surface height. For internal surfaces , draft values should be higher than those for external ones. Loose parts and complex parting lines should be avoided , if possible , if possible on the patterns.
2. Avoiding large horizontal surfaces on the top of mould , since gas evolved by the metal and in the mould may be trapped on the surfaces causing cavities and pinholes.
3. Avoiding abrupt changes in the path of molten metal
4. Equal rate of cooling in all section of castings and allow unrestricted shrinkage
5. Form of casting should be such that all feeding heads , risers , runners , sprues and gates can be easily cut off , all cores knocked out and core irons removed.
6. One datum surface along each of the three space coordinates
7. The size and weight of casting , type of alloy employed , and the casting method should be considered for designing wall thickness
8. Rib design depends on the overall dimensions of the casting and their size is in definite relation to wall thickness

9. Corner radii at junctions may range from 2 mm to 120 mm depending on overall dimensions and the angle between them.
10. Rate of cooling for outside corners is always higher than that of inside corners.
11. Bosses are provided at places where holes are to be drilled.

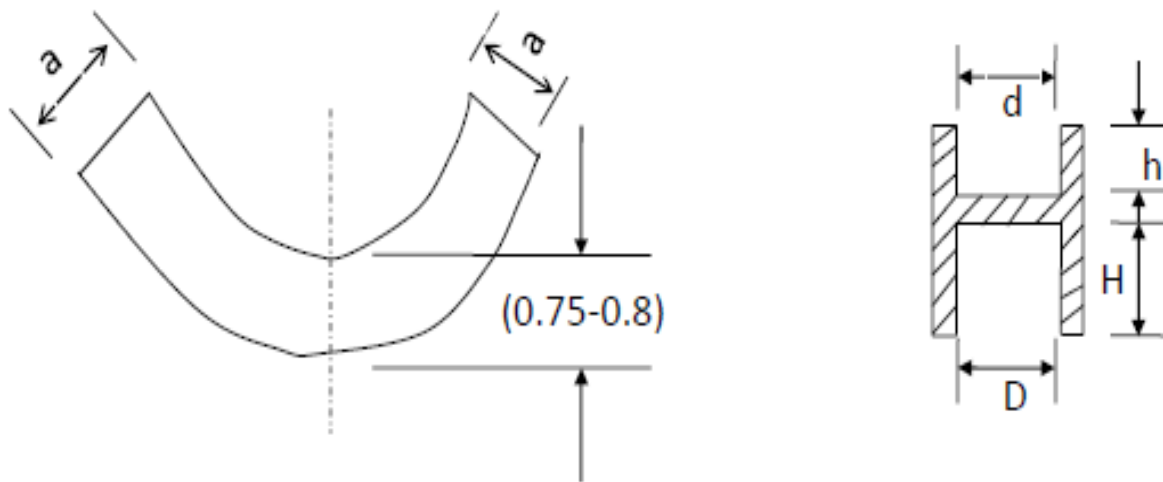

$$H \leq DH \leq 0.5D$$

M/C moulding  $H \leq 0.15d$

### Design principles for die casting

1. Die casting should be thin walled structures
  - Zn → 1 to 1.5 mm
  - Al, Mg → 30-50% thicker
  - Cu → 2 to 3 mm thick
  - Fine grain structure with minimum amount of porosity and good mechanical properties.
  - Large die castings are designed with 5 mm thick walls and sections with 10 mm thick
2. As a general rule thickness of projections where they meet main wall should not exceed 80% of the main wall thickness
3. Features projecting from the side walls of casting should not, if possible lie behind one another when viewed in the direction of the die opening
4. Internal wall depressions or internal undercuts should be avoided in casting design ; since moving internal core mechanisms are virtually impossible to operate with die casting

## Design consideration:

- (i) Maintain uniform section thickness
- (ii) Ribs and webs may be staggered to eliminate hot spots
- (iii) At points of metal concentration cored holes may be provided
- (iv) Design to promote directional solidification
- (v) Avoid thin sections between heavy sections and risers
- (vi) Prevent occurrence of isolated hot spots difficult to feed
- (vii) Keep plates in tension and ribs in compression according to performance requirement
- (viii) Minimum section thickness is determined by the flow ability of metal being cast

## Casting tolerances

Factors:

- 1) Casting design
- 2) Material being cast
- 3) Condition of pattern and material
- 4) Mould material
- 5) Assembly of mould boxes
- 6) Mould swelling
- 7) Felting
- 8) Heat treatment

Tolerances for sand castings mm(upto 300 mm thick

Steel castings	1.5
Cast Irons	1.2
Alluminium alloys	0.8
Copper alloys	2.4



Tolerances expected on shell moulds and Sand moulds for Grey Iron and steel castings

Tolerances expected on shell moulds and Sand moulds for Grey Iron and steel castings

Basic size	Tolerance in mm sand moulds hand moulding	Machine moulds Metal / Epoxy	Shell Moulding
0-25 mm	2-2.5	1.2-2.0	0.8-1
26-50 mm	2.5-3.5	2-2.5	1-1.2
51-100	3.5-4.5	2.5-3.5	1.2-1.5
200 mm	4.5-6.0	3.5-4.5	1.5-1.8
400 mm	6-8	4.5-6.0	1.8-2.4
800 mm	8-11	6-7.5	2.4-3.2

## **SOLIDIFICATION**

### **Directional solidification :**

#### **Factors :**

1. High thermal conductivity and high heat capacity mould material High degree of progressive solidification
2. Short liquidous to solidous range solidifying metals – high degree
3. Low thermal conductivity of solidifying metal high degree
4. High solidification temperature – steep thermal gradient – high degree

#### **Measures :**

1. Proper gating and risering
2. Control of pouring rate and temperature
3. Differential heating using exothermic riser

4. Differential cooling using chills
5. Use of padding
6. Use of mould materials with different thermal conductivities for different mould parts

**Requirements for sound casting:**

1. Progressive solidification
2. Directional solidification Proceed from most distant points towards the riser
3. temperature gradient to be steep enough to keep the angle  $\alpha$  large to eliminate shrinkage void
4. If progressive solidification is not proper all the points from outer to inner of the casting do not reach centre line at the same time , causing centre line shrinkage / micro shrinkage / shrinkage porosity

**Simulation of solidification:**

Complete and physically accurate simulation of metal casting process is difficult programs

AUTO CAST	BOMBAY
CAP/WRAFTS	USA
CAST FLOW	FINLAND
JS CAST	AUSTRALIA
MAGM SOFT	JAPAN
MAVIS	GERMANY
MAVIS	UK

Casting simulation is a powerful tool to visualize mould filling , solidification and cooling , predicting defect location.

Trouble shooting existing castings and developing new castings

**INPUT DATA**

- 1) 3d cad model of casting
- 2) Material
- 3) Geometry
- 4) Process

**GEOMETRY**

(I) Part features

Convex and concave regions

Cored holes

Pockets

Bosses

Ribs

Various junctions (2d and 3d)

THESE AFFECT SOLIDIFICATION OF METAL

(II) Layout in mould No. Of cavities , locations (inter cavity gap and cavity to wall gap)

(III) Feed aids Including number , shape , size , location of insulating sleeves and covers , chills (external and internal ) and padding

These influence rate of heat transfer material

(I) Thermo-physical properties of metal ; density , specific heat , thermal conductivity , latent heat , volumetric contraction during solidification , coefficient of linear expansion viscosity and surface tension Thermo physical properties of mould : core , and feed aid materials , including density , specific heat , thermal conductivity , coefficient of linear expansion and modulus extension factor

(II) Changes in properties with composition and temperature , relevant transformations (grain shape , structure , distribution ) and resultant mechanical properties

PROCESS :

(1) Flow pattern of molten metal :

(2) Solidification (heat transfer)

(3) Solid state cooling

(4) Process parameters

( composition of metal , mould size , mould compaction , mould coating , mould temperature , pouring temperature and rate , mould cooling , shake out etc.

Benefits of casting simulation

1) Customer satisfaction

2) Faster development

3) Lower rejection

4) Higher yield

5) Cost reduction

Bottlenecks

1) Trained manpower required

- 2) Technical support
- 3) Maintenance
- 4) Initial cost

Major advantages :

- 1) Reduced shop floor trials
- 2) Value addition
- 3) Knowledge management

India : only 5% use simulation where as germany 90% usa 75% Hyderabad : snit (iif r&d centre)

General guidelines for sand casting

- 1) Computer – based solidification modelling
- 2) Shape of the casting should allow for orderly solidification
- 3) Difference in thicknesses of adjoining sections should not exceed 2 to 1%
- 4) Wedge – shaped changes in wall thickness should not exceed taper 1 to 4
- 5) Thickness of boss or pad
- 6) Radius for good shrinkage control should be from  $1\frac{1}{2}$  to  $1/3$  of the section thickness
- 7) Two ribs should not cause each other
- 8) A draft or taper of from 6 to 3 degrees is required on vertical faces so that pattern can be removed from mould

## **METAL JOINING PROCESSES**

Appraisal of various welding processes

- |              |   |                              |
|--------------|---|------------------------------|
| Homogenous   | - | matching composition filler  |
| Autogenous   | - | same metals involved         |
| Heterogenous | - | entirely different materials |

## CLASSIFICATION

### FUSION WELDING

ARC WELDING  
MMAW  
GMAW  
GTAW  
SAW  
EGW  
ESW  
PLASMA ARC  
EBW  
LASER  
ARC STUD  
CAPACITAR DISCHARGE  
GAS WELDING  
THERMIT WELDING

### PRESSURE WELDING

COLD PRESSURE  
HOT PRESSURE  
FW, FBW,UBW  
DB,USW  
FSW,UBW  
ROLL BONDING  
SMALL TOOL WELDING  
ROTATING ARC  
( MAGNETICALLY  
IMPELLED ARC  
BUTT WELDING)

### FUSION UNDER PRESSURE

SPOT  
SEAM  
PROJECTION

### Brazing

Base metals not melted

Filler mp above 450°C

Wetting , spreading capillary action to make the molten filler fill the capillary gap and solidification creates metallurgical bond

Processes : (based on heat generated)

- 1) Flame
- 2) Saltbath
- 3) Furnace
- 4) Induction
- 5) Resistance

### Soldering

Base metals not melted soldering filler mp



Processes :

- 1) Flame
- 2) Heated tool
- 3) Soldering iron (electric)
- 4) Dip soldering
- 5) Wave soldering

### **Adhesive bonding**

Use of adhesives to join metals and metals to non-metals

Adhesive :

Thermosetting plastics

Phenol formaldehyde

- (1) Cleaning
- (2) Application of adhesive to the faying surfaces
- (3) Curing under pressure

Joint design – welding

- 1) Butt joints
- 2) Lap joints
- 3) T joint
- 4) Edge joints

Joint design – brazing & soldering

- 1) Lap joints
- 2) Modified butt-lap joints

Edge preparation

- 1) Single v
- 2) Double v
- 3) Single u
- 4) Double u
- 5) J edge preparation
- 6) Corner joint
- 7) Double lap

Criteria : "minimum weld metal"

"shrinkage stresses when liquid metal solidified "

"higher the amount of molten metal more shrinkage stresses "

- residual stresses & distortion " are related to differential heating and cooling

### **Welding design**

- 1) Selection of materials
- 2) Joint design
- 3) Selection of welding process
- 4) Minimizing of stresses
- 5) Differential heating and cooling
- 6) Microstructure bm, weld , haz
- 7) Weldability
  - a) process
  - b) material
  - c) service

### **Guidelines:**

- 1) Welded designs should reflect the flexibility and economy inherent in the welding process
- 2) In the design of welded joints , provide for straight force flow lines avoid use of welded straps , laps , and stiffeners except as required for strength. Use minimum number of welds.
- 3) Weld together parts of equal thickness whenever possible
- 4) Locate the welds at areas in the design where stresses and or deflections are least critical
- 5) Carefully consider the sequence with which parts should be welded together and include that information as part of the engineering drawing
- 6) Make sure that the welder or welding machine has unobstructed access to the joint so that a quality weld can be produced
- 7) Whenever possible , the design should provide for welding in the flat or horizontal position , not overhead

### **Preheating:**

- 1) Base metals heated to required particular temperature to reduce the affect of colling rate
- 2) Preheating temperature is function of ce and base metal thickness for steels
- 3) Higher thermal conductivity metals require preheating to reduce cooling rate
- 4) Residual stresses can be minimized by preheating
- 5) Distortion can be controlled by preheating
- 6) Cold cracking can be avoided as hydrogen is diffused out
- 7) Microstructure of weld and haz will be controlled
- 8) Fluidity of weld metal can be increased
- 9) Material weldability can be improved

### **Post Heating & Post weld Heat treatment post heating:**

Heating the joint area to a required temperature immediately after welding is completed post weld heat treatment :

- 1) Changing the metallurgical structure of a part , there by improving mechanical properties
- 2) Processes of heat treatment
- 3) Annealing
- 4) Heating , soaking , furnace cooling relieving of residual stress , homogenising cast structure , remove hardening effects of cold working and improve ductility
- 5) Quenching :
- 6) Heating to austenising temperature and sudden cooling
- 7) Q&t : quenching and tempering heating below transformation temperature and cooling slowly for tempering
- 8) This improves toughness
- 9) Solutionising and aging (non ferrous)
- 10) Heating to solutionising temperature
- 11) Aging allowed for longer time to form fine precipitates
- 12) (precipitation hardening)

### **Design for Heat Treatment:**

- 1) Long thin parts prove to distortion
- 2) Distortion due to relieving of residual stresses
- 3) Quenching may produce quench cracks
- 4) Local plastic deformation – causes distortion

- 5) Minimizing stress concentration
- 6) Use of sysweld software for design simulation  
(heat treatment and welding)

The simulation software provides visualization of distortion as determined by joint design welding conditions, and metallurgical transformation of particular steel

Effect of thermal stresses

- 1) Residual stresses (locked up stresses)  
system stresses that exist when part is free from external forces  
cause : non-uniform plastic deformation of a solid  
(inhomogeneous changes in volume)
- 2) Longitudinal residual stress and transverse residual stress
- 3) Residual stresses arising from thermal processes may be classified as those due to a thermal gradient alone or to a thermal gradient in conjunction with a phase transformation
- 4) Control of residual stresses starts with understanding fundamental source of stress and identifying parameters in the manufacturing process
- 5) The magnitude of residual stresses should not be greater than yield stress
- 6) Stress relieving temperature to be selected depending on composition of materials. Soaking time to be as per thickness of materials.
- 7) Fatigue loading requires minimizing residual stresses to very low level and tensile component should be controlled
- 8) Chemical processes such as oxidation, corrosion, and electroplating can generate large surface residual stresses other surface chemical treatments such as carburizing and nitriding cause residual stresses
- 9) The differential strains that produce high residual stresses also can be eliminated by plastic deformation at room temperature. Products such as sheet, plate and extrusions are often stretched several percent beyond their yield stress to relieve differential strains by yielding
- 10) Inducing compressive stresses on surface has advantageous effect. This can be done by rolling or shot peening. One should note that subsurface residual stresses may still exist

### **Design for Brazing**

- 1) Strength of joint depends on strength of filler

- 2) Bonding area determines the strength
- 3) Lap joints are better than butt joints
- 4) Modified butt – lap joints are better than butt or lap joints
- 5) Capillary gap to be maintained throughout brazing cycle
- 6) Joint design should facilitate positioning of filler
- 7) Joint design should consider brazing process to be employed
- 8) Temperature distribution near the joint gap important for capillary action

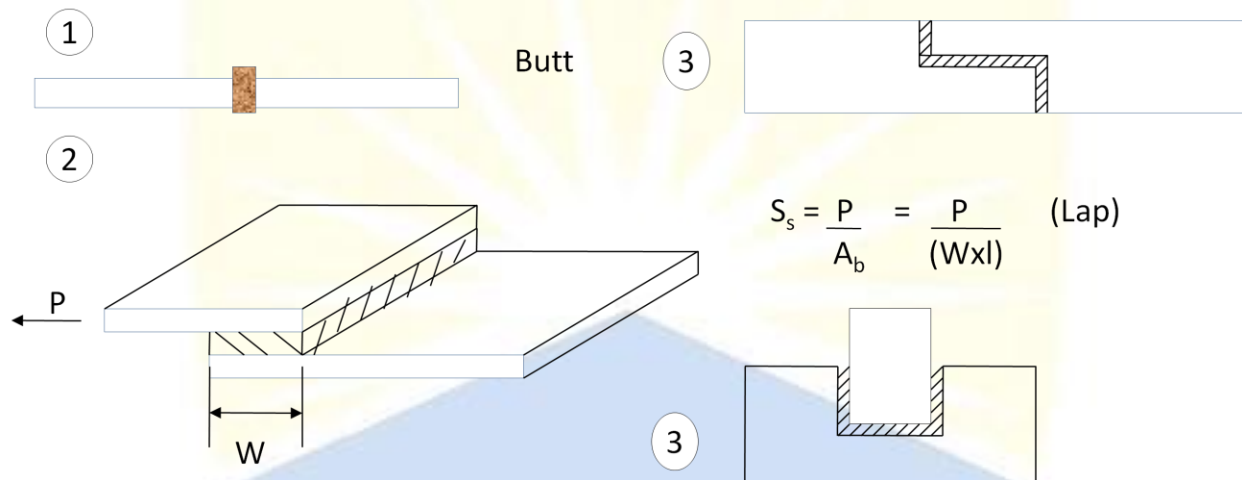

EDUCATION FOR LIBERATION  
**IARE**  
 MECHANICAL



## Forging:

Forging processes are among the most important means of producing parts for highperformance applications. Forging is typical of a group of bulk deformation processes in which a solid billet is forced under high pressure by the use of a press to undergo extensive plastic deformation into a final near-to-finished shape. Other examples of deformation processes are *extrusion*, in which a long object with a high L/D ratio is produced by pushing a metal billet through a die, *drawing*, in which a billet is pulled through a die, and *rolling*, in which a slab is passed through rolls to make a thin sheet.

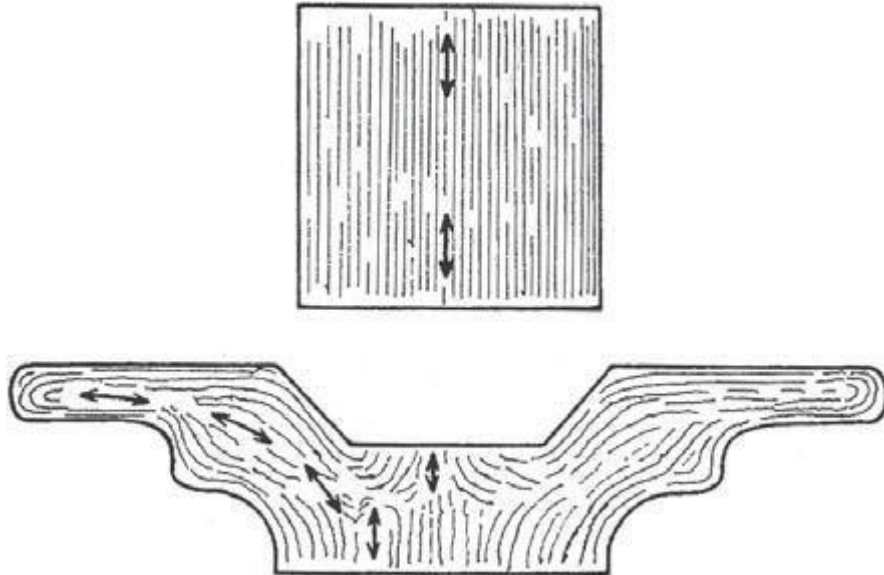

Figure 4.1 The redistribution of the fiber structure direction during the forging of a part.

### Design guidelines for closed – die forging:

1. Vertical surfaces of a forging must be tapered to permit removal of the forging from die cavity  
external (5 to 7 °C) internal (7 to 10°C)
2. The maximum flash thickness should not be greater than ¼ in or less than 1/32 in on
  - a. average
3. Webs are the sections of a forging normal to the motion of the moving die and ribs are the relatively thin sections parallel to die motion. These features are easiest to form by the deforming metal when ribs are not too high and narrow and the web is relatively thick and uniform
4. The parting line, where the die halves meet, is an important design consideration because its location helps to influence grain flow, die costs, and die wear. For optimum economy it should be kept to a single plane if at all possible, since that will make die sinking, forging and trimming less costly.
5. Wherever possible in the design of forgings, as in the design of castings, it is desirable to keep the thickness of adjacent sections as uniform as possible. Rapid changes in section thickness should be avoided. To avoid defects like laps, cracks generous radii must be provided.

6. Most forging is done at elevated temperature where the flow stress of material is much lower than at room temperature. In order to account for oxidation, correcting for warpage and mismatch, and for dimensional mistakes due to thermal contraction or die wear, machining allowance has to be given.

**Design guidelines for forging:**

-Net shape technology|| Bulk deformation processes press is used for causing extensive bulk plastic deformation

Extrusion → high L/d ratio

Drawing →

Rolling →

Generally hot working carried out Extensive plastic deformation causes metallurgical changes porosity closed up, grain structure and second phases are deformed and elongated in the principal directions of working, creating a fiber structure|. Properties are not same on all directions of maximum plastic deformation(longitudinal) should be aligned with the direction of the part that needs to carry the maximum stress. Open die forging use flat dies for simple shapes

Forging design guidelines

1. For flat die forging, intersections of two or more cylindrical elements should be avoided Ribbed cross sections should be avoided

Bosses, projections, pads etc should be avoided on the main surfaces of forging projects inside the prongs of fork type parts to be avoided.

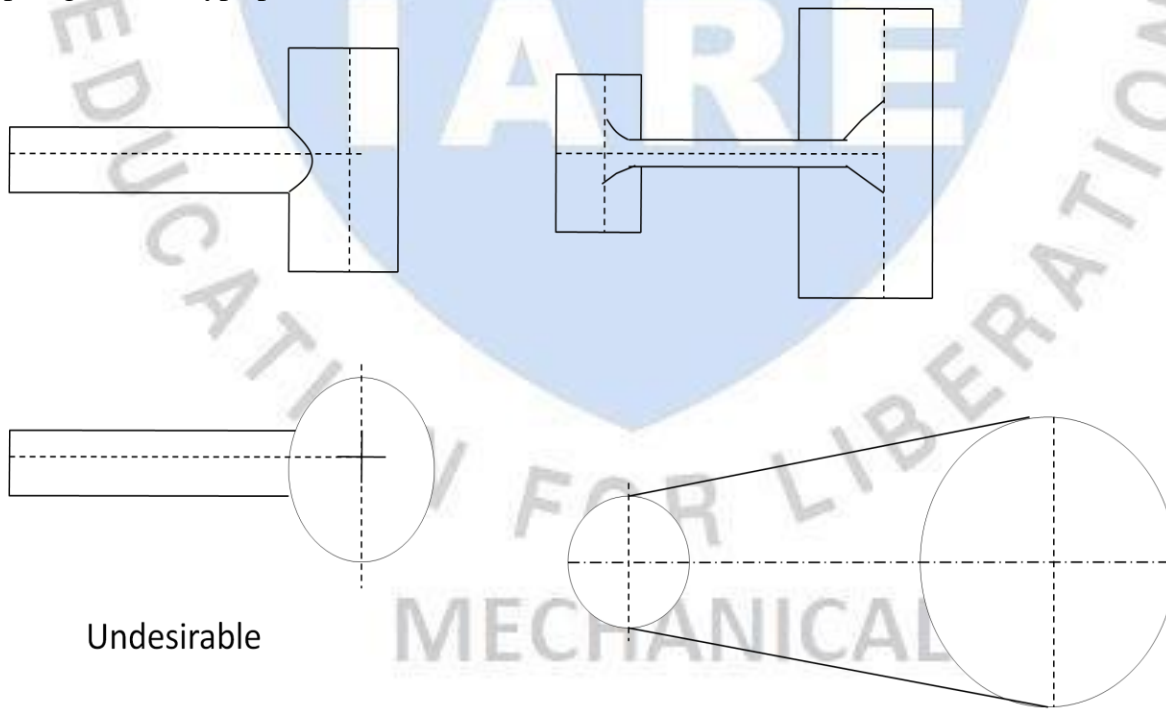

Undesirable

Undesirable

2. Replace components having complex shape by units consisting of simple welded or assembled elements

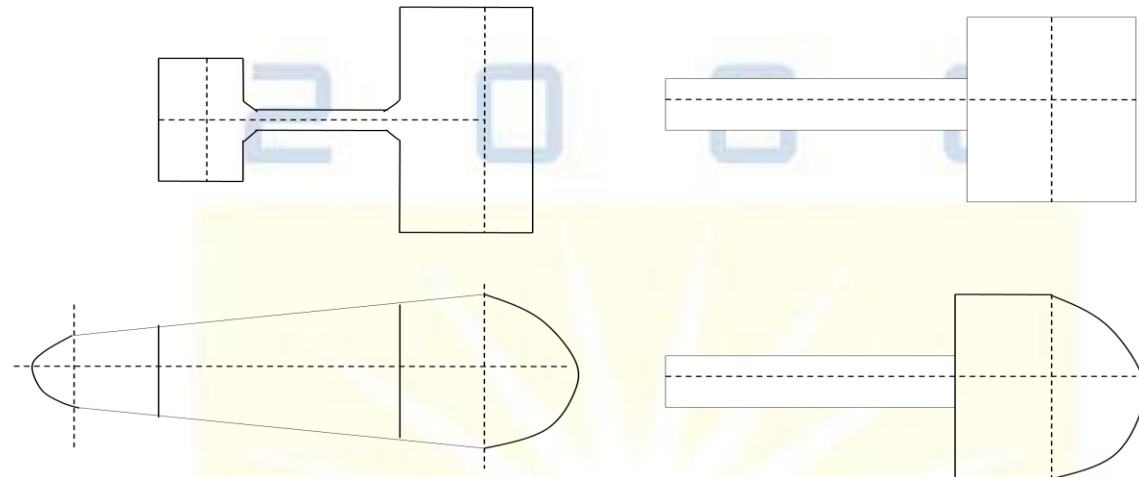

#### Designing forgings for horizontal forging machines

1. The wall thickness of forging with deep , through or blind holes should not be less than 0.15 of the outside diameter
2. Reductions in cross-section along the length of forging should be avoided because they impede metal flow during forging process
3. Shanks of taper form are also difficult to forge and they should be replaced by cylindrical shanks
4. Volume of the located at the ends or in the middle of a forging must not exceed the volume of a bar having the given diameter  $d$  and length of 10-12  $d$
5. Draft for this type of forging may be very small and draft of  $0.5^\circ$  is suitable for the cylindrical section of the forging up-set within punch cavity and of a length more than  $1 \frac{1}{2}$  of the diameter. A draft of  $0.5-1.5^\circ$  is suitable for shoulders formed in the circular impressions of dies and  $0.5-3^\circ$  on the wall of blind holes with a length of 5 or more diameters
6. Transition from one surface to another must have fillets with radii from 1.5-2 mm.
7. Carbon and alloy steel fasteners and similar parts having an annealed hardness 120-207 bhn are produced by cold heading

In cold heading , the head should be simple form with a minimum volume an diameter. Close tolerance should not be specified for the headed parts as die life will be reduced. Fillet radii 0.2 mm to be provided at all corners

#### Design guidelines for extruded sections:

- 1) Areas of billet and extrusion ; or corresponding diameters to be considered (  $a_0$  ,  $a_1$  ,  $d_0$  ,  $d_1$  )
- 2) Engineering strain to be accounted (  $a_0 - a_1$  ) /  $a_0$
- 3) Strain rate effect to be considered

- 4) Hot extrusion temperature and its effect on oxidation ; flow of material , surface finish
- 5) Selection of type of extrusion – cold , hot , impact , hydrostatic
- 6) Selection of extrusion process based on material

eg :

- 1) impact extrusion for soft metals
- 2) hot extrusion for steels
- 3) cold extrusion for ductile materials
- 4) clad extrusion for zirconium alloys

#### Extrusion Design Tips

1. Wall thickness :

based on strength and cost profiles with uniform wall thickness are the simplest to produce wall thickness within a profile can be varied

2. Radi used corners , soft lines
3. Be symmetrical
4. Have a small circumscribing circle
5. Not have , deep , narrow channels
6. Solid profiles if possible
7. Fewer cavities in hollow profiles
8. Profiles – width to height ratio 1:3
9. Decoration
10. Symmetrical shape
11. Narrow shapes with deep gaps can cause problems

#### Design guidelines for sheet metal bending:

- 1) Minimum inside radius equal to material thickness
  - 2) Bend radius 4 to 8 times material thickness to avoid cracking
  - 3) Minimum flange length 4 times material thickness
  - 4) Bend relief → length greater than radius of bend
- the bend allowance  $l_{ba}$  , the length of the neutral axis in bend is given by

$$l_{ba} = \alpha (r_b + k_t)$$

$\alpha$  is bend angle in radians ,

$r_b$  is the bend radius (measured to the inside of the bend)

and  $t$  is thickness of the sheet

if  $r_b > 2t$  ;  $k=0.5$

if  $r_b > 2t$  ;  $k=0.5$

during bending there is a –spring back, to account for this , the metal must be bent to a smaller angle and sharper radius , so that when the metal springs back , it is at the desired values.

another method is to advance punch more than what is required to bend radius

- 5) Bending across –metal grain avoids cracking
- 6) Bend radius should not be less than sheet thickness

Design guidelines for blanking:

- 1) Simple blank contours to be used as die cost depends on the length and the intricacy of the contour of blank
- 2) It may be less experience to construct a component from several simple parts than to make an intricate blanked part
- 3) Notching a blank along one edge results in an unbalanced force that makes it difficult to control dimensions as accurately as with blanking around the entire contour.  
usual tolerances on blanked parts are  $\pm 0.075$  mm
- 4) Diameter of punched holes should not be less than the thickness of sheet
- 5) Minimum distance between holes or between hole and the edge to the sheet thickness
- 6) If holes have to be threaded , the sheet thickness must be at least one-half the thread diameter

Design guidelines for stretching and deep drawing

- 1) Deep drawing deformation conditions are different than in stretching
- 2) Success in deep drawing is enhanced by factors that restrict thinning : die radius about 10 times the sheet thickness ; a liberal punch radius , and adequate clearance between punch and die
- 3) Deep drawing is facilitated if crystallographic texture of sheet is such that the slip mechanisms favor deformation in the width direction over the slip in the thickness direction of the sheet  
plastic strain ratio  $r$  given by

$r =$  strain in width direction of tension specimen



strain in thickness direction

- 4) Keeler – goodwin forming limit diagram → a material of greater formability in which the forming limit diagram was at higher values could be safe to avoid failure
- 5) The failure could be eliminated by changing metal flow by either design changes to die or to part so that strain state is in the safe zone

Design rules for blanking components

- 1) Profile shape should not contain narrow projections
- 2) Internal punched holes should be separated from each other
- 3) Dimension  $a'$  to  $d'$  should be greater than ( twice of thickness ) sheet thickness
- 4) It is good practice to have relief cutouts dimensioned as  $d'$  at the ends of proposed bends
- 5) Tensile strains for different materials must be estimated and compared to the permissible maximum value
- 6) Louvers are formed for cooling purpose. The length of the front edge of louver must be greater than a certain multiple of louver opening height , determined by the material ductility , and the end ramp angles

## UNIT – IV

### ASSEMBLY ADVANTAGES

#### Introduction:

Design for assembly (DFA) should be considered at all stages of the design process, but especially during the early stages. As the design team conceptualizes alternative solutions, it should give serious consideration to the ease of assembly of the product or subassembly. The team requires a DFA tool to effectively analyze the ease of assembly of the products or subassemblies it designs. The design tool should provide quick results and be simple and easy to use. It should ensure consistency and completeness in its evaluation of product assemblability. It should also eliminate subjective judgment from design assessment, allow free association of ideas, enable easy comparison of alternative designs, ensure that solutions are evaluated logically, identify assembly problem areas, and suggest alternative approaches for simplifying the product structure—thereby reducing manufacturing and assembly costs.

The DFA method accomplishes these objectives by:

1. Providing a tool for the designer or design team which assures that considerations of product complexity and assembly take place at the earliest design stage. This eliminates the danger of focusing exclusively during early design on product function with inadequate regard for product cost and competitiveness.
2. Guiding the designer or design team to simplify the product so that savings in both assembly costs and piece part costs can be realized.
3. Gathering information normally possessed by the experienced design engineer and arranging it conveniently for use by less-experienced designers.
4. Establishing a database that consists of assembly times and cost factors for various design situations and production conditions.

The analysis of a product design for ease of assembly depends to a large extent on whether the product is to be assembled manually, with special-purpose automation, with general-purpose automation (robots), or a combination of these. For example, the criteria for the ease of automatic feeding and orienting are much more stringent than those for manual handling of parts. In this chapter, we introduce design for manual assembly, since it is always necessary to use manual assembly costs as a basis for comparison. In addition, even when automation is seriously considered, some operations may have to be carried out manually, and it is necessary to include the cost of these in the analysis.

#### General Design Guidelines for Manual Assembly

As a result of experience in applying DFA, it has been possible to develop general design guidelines that attempt to consolidate manufacturing knowledge and present them to the designer in the form of simple rules to be followed when creating a design. The process of manual assembly can be divided naturally into two separate areas, handling (acquiring, orienting, and moving the parts), and insertion and fastening

(mating a part to another part or group of parts). The following design for manual assembly guidelines specifically address each of these areas.

In general, for ease of part handling, a designer should attempt to:

1. Design parts that have an end-to-end symmetry and rotational symmetry about the axis of insertion. If this cannot be achieved, try to design parts having the maximum possible symmetry (see Figure 3.1a).
2. Design parts that, in those instances where the part cannot be made symmetric, are obviously asymmetric (see Figure 3.1b).
3. Provide features that prevent jamming of parts that tend to nest or stack when stored in bulk (see Figure 3.1c).
4. Avoid features that allow tangling of parts when stored in bulk (see Figure 3.1d).
5. Avoid parts that stick together or are slippery, delicate, flexible, very small or very large, or that are hazardous to the handler (i.e., parts that are sharp, splinter easily, etc.) (see Figure 3.2).

### **Design Guidelines for Insertion and Fastening**

For ease of insertion, a designer should attempt to:

1. Design so that there is little or no resistance to insertion and provide chamfers to guide the insertion of two mating parts. Generous clearance should be provided, but care must be taken to avoid clearances that result in a tendency for parts to jam or hang-up during insertion (see Figures 3.3 through 3.6).
2. Standardize by using common parts, processes, and methods across all models and even across product lines to permit the use of higher volume processes that normally result in lower product cost (see Figure 3.7).

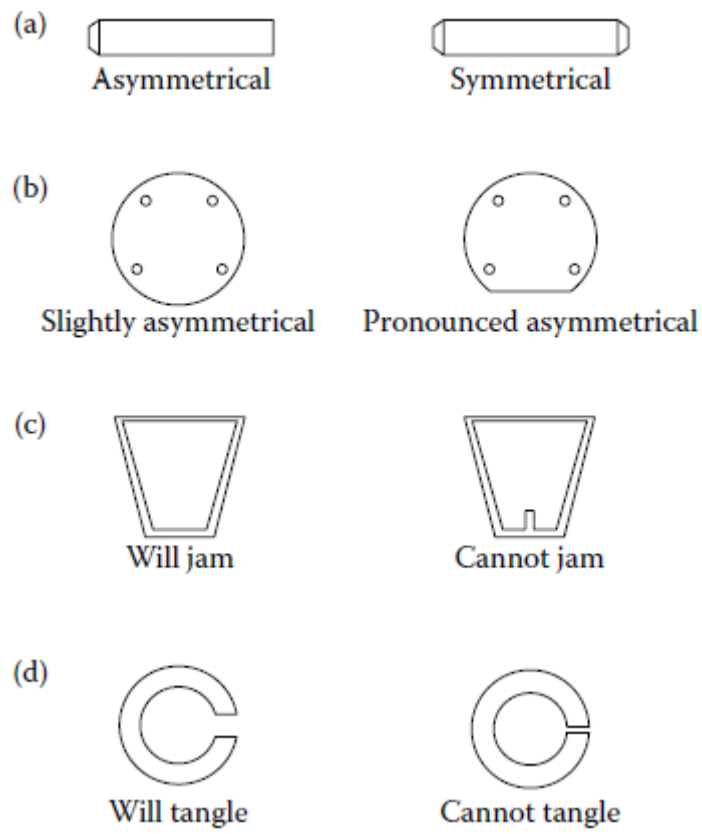

Figure 3.1 Geometrical features affecting part handling.

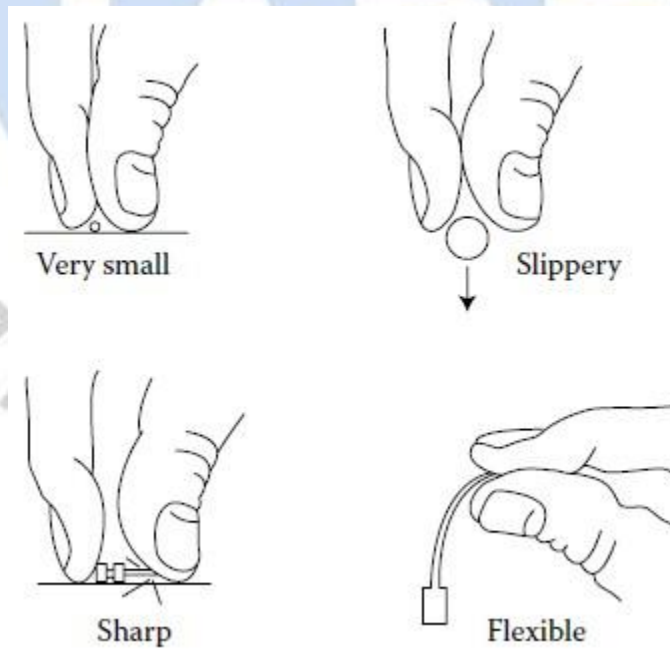

Figure 3.2 Some other features affecting part handling.

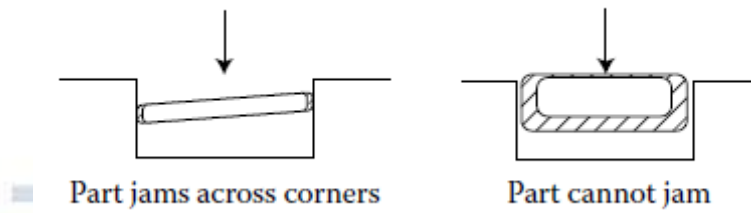

Figure 3.3 Incorrect geometry can allow a part to jam during insertion.

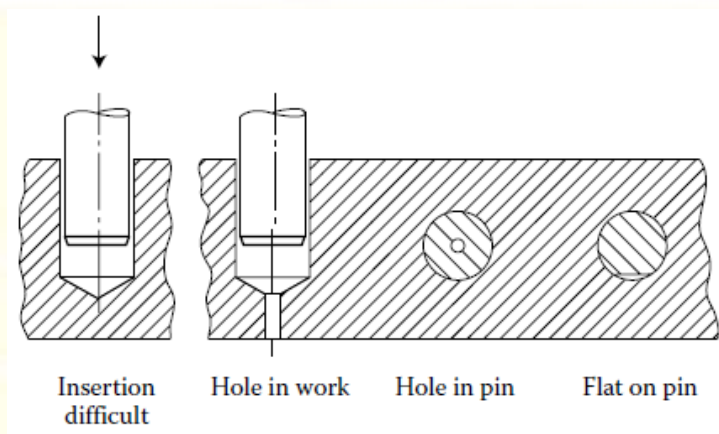

Figure 3.4 Provision of air-relief passages to improve insertion into blind holes.

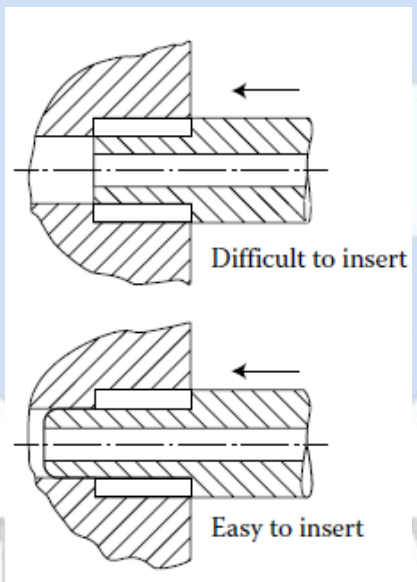

Figure 3.5 Design for ease of insertion—assembly of long-stepped bushing into counter bored hole.



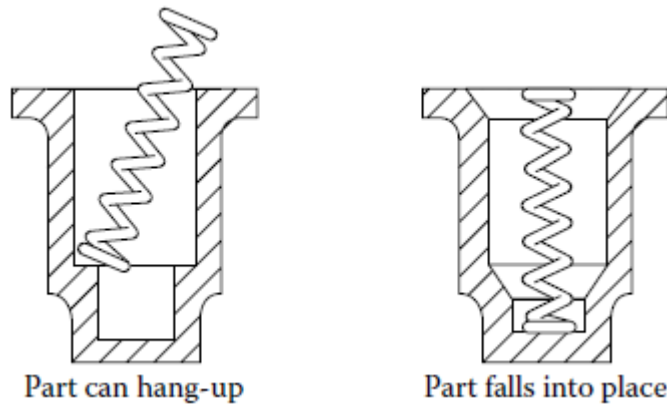

Figure 3.6 Provision of chamfers to allow easy insertion.

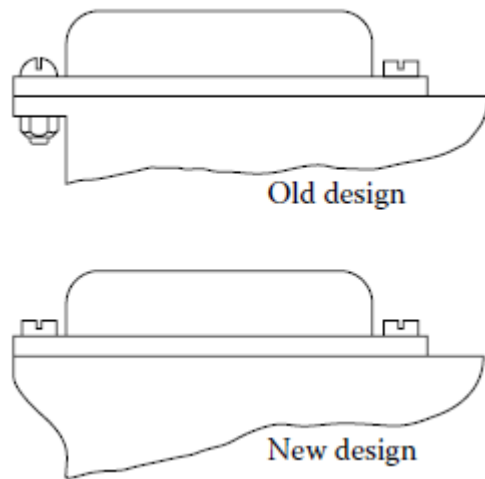

Figure 3.7 Standardize parts.

3. Use pyramid assembly—provide for progressive assembly about one axis of reference. In general, it is best to assemble from above (see Figure 3.8).
4. Avoid, where possible, the necessity for holding parts down to maintain their orientation during manipulation of the subassembly or during the placement of another part (see Figure 3.9). If holding down is required, then try to design so that the part is secured as soon as possible after it has been inserted.

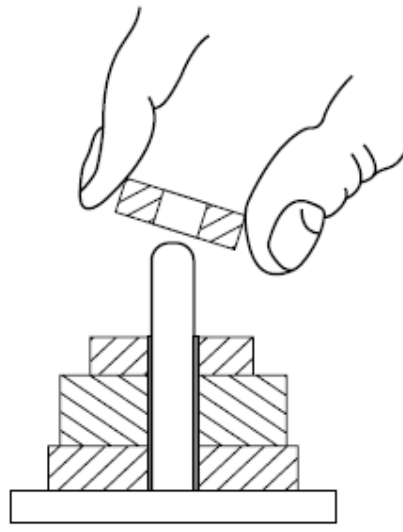

Figure 3.8 Single-axis pyramid assembly.

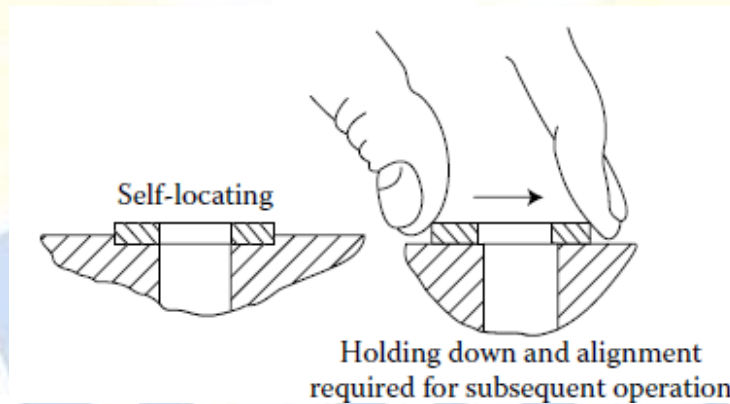

Figure 3.9 Provision of self-locating features to avoid holding down and alignment.

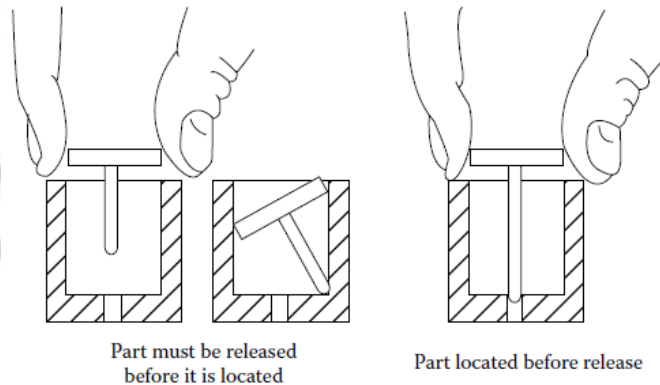

Figure 3.10 Design to aid insertion.

5. Design so that a part is located before it is released. A potential source of problems arises from a part being placed where, due to design constraints, it must be released before it is positively located in the assembly. Under these circumstances, reliance is placed on the trajectory of the part being sufficiently repeatable to locate it consistently (see Figure 3.10).

6. When common mechanical fasteners are used, the following sequence indicates the relative cost of different fastening processes, listed in the order of increasing manual assembly cost (Figure 3.11).

- a. Snap fitting
  - b. Plastic bending
  - c. Riveting
  - d. Screw fastening
7. Avoid the need to reposition the partially completed assembly in the fixture (see Figure 3.12).

General rules are useful to follow when DFA is carried out. However, guidelines are insufficient in themselves for a number of reasons. First, guidelines provide no means by which to evaluate a design quantitatively for its ease of assembly. Second, there is no relative ranking of all the guidelines that can be used by the designer to indicate which guidelines result in the greatest improvements in handling, insertion, and fastening; there is no way to estimate the improvement due to the elimination of a part, or due to the redesign of a part for handling, and so on. It is, then, impossible for the designer to know which guidelines to emphasize during the design of a product.

Finally, these guidelines are simply a set of rules that, when viewed as a whole, provide the designer with suitable background information to be used to develop a design that would be more easily assembled than a design developed without such a background. An approach must be used that provides the designer with an organized method that encourages the design of a product that is easy to assemble. The method must also provide an estimate of how much easier it is to assemble one design, with certain features, than to assemble another design with different features. The following discussion describes the DFA methodology, which provides the means of quantifying assembly difficulty.

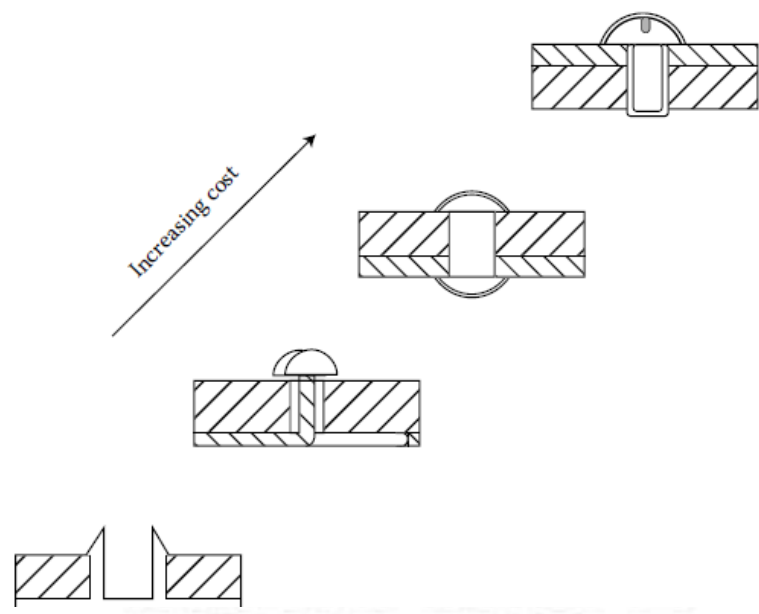

Figure 3.11 Common fastening methods.

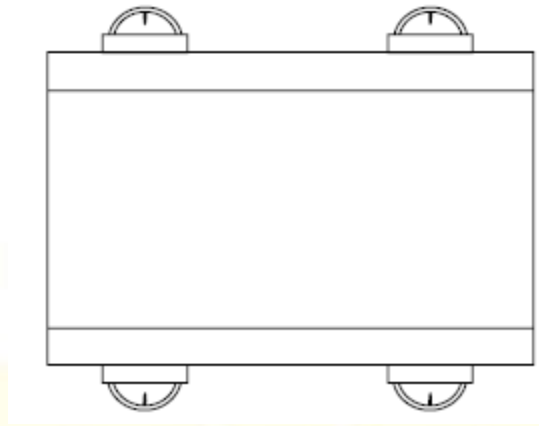

Figure 3.12 Insertion from opposite direction requires repositioning of the assembly.

### **Development of the Systematic Design for Assembly Methodology**

Starting in 1977, analytical methods were developed [2] for determining the most economical assembly process for a product and for analyzing ease of manual, automatic, and robot assembly. Experimental studies were performed [3–5] to measure the effects of symmetry, size, weight, thickness, and flexibility on manual handling time. Additional experiments were conducted [6] to quantify the effect of part thickness on the grasping and manipulation of a part using tweezers, the effect of spring geometry on the handling time of helical compression springs, and the effect of weight on handling time for parts requiring two hands for grasping and manipulation.

Regarding the design of parts for the ease of manual insertion and fastening, experimental and theoretical analyses were performed [7–11] on the effect of chamfer design on manual insertion time, the design of parts to avoid jamming during assembly, the effect of part geometry on insertion time, and the effects of obstructed access and restricted vision on assembly operations.

A classification and coding system for manual handling, insertion, and fastening processes, based on the results of these studies, was presented in the form of a time standard system for designers to use in estimating manual assembly times [12,13]. To evaluate the effectiveness of this DFA method, the ease of assembly of a two-speed reciprocating power saw and an impact wrench were analyzed and the products were then redesigned for easier assembly [14]. The initial design of the power saw (Figure 3.13) had 41 parts and an estimated assembly time of 6.37 min. The redesign (Figure 3.14) had 29 parts for a 29% reduction in part count, and an estimated assembly time of 2.58 min for a 59% reduction in assembly time. The outcome of further analyses [14] was a more than 50% savings in assembly time, a significant reduction in parts count, and an anticipated improvement in product performance.

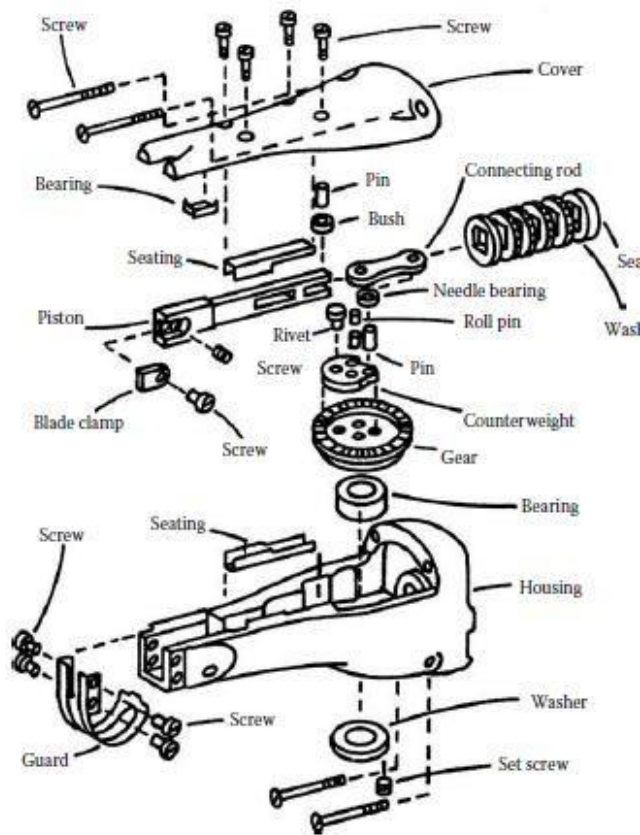

Figure 3.13 Power saw (initial design—41 parts, 6.37 min assembly time).

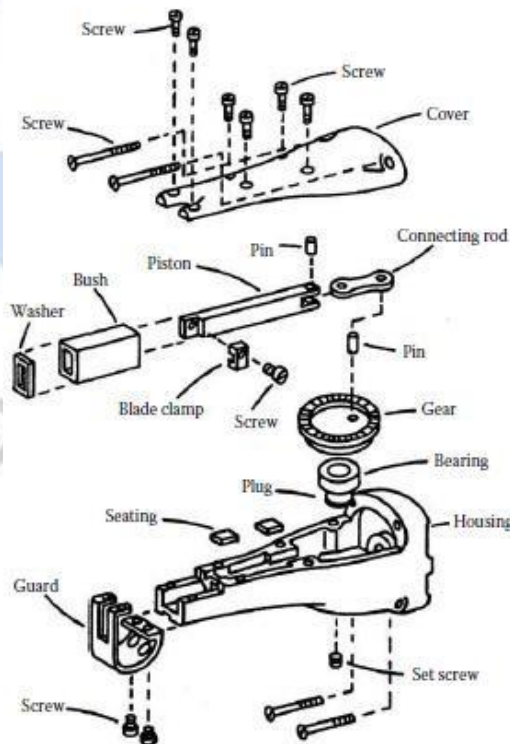

Figure 3.14 Power saw (new design—29 parts, 2.58 min assembly time).



## UNIT V

### DESIGN FOR MANUAL ASSEMBLY

#### Assembly Efficiency

An essential ingredient of the DFA method is the use of a measure of the DFA index or -assembly efficiency of a proposed design. In general, the two main factors that influence the assembly cost of a product or subassembly are:

- The number of parts in a product
- The ease of handling, insertion, and fastening of the parts

The DFA index is a figure obtained by dividing the theoretical minimum assembly time by the actual assembly time. The equation for calculating the DFA index  $E_{ma}$  is

$$E_{ma} = \frac{N_{min}t_a}{t_{ma}} \quad (3.1)$$

where  $N_{min}$  is the theoretical minimum number of parts,  $t_a$  is the basic assembly time for one part, and  $t_{ma}$  is the estimated time to complete the assembly of the product. The basic assembly time is the average time for a part that presents no handling, insertion, or fastening difficulties (about 3 s).

The figure for the theoretical minimum number of parts represents an ideal situation where separate parts are combined into a single part unless, as each part is added to the assembly, one of the following criteria is met:

1. During the normal operating mode of the product, the part moves relative to all other parts already assembled. (Small motions do not qualify when they can be obtained through the use of elastic hinges.)
2. The part must be of a different material, or be isolated from all other parts assembled (for insulation, electrical isolation, vibration damping, etc.).
3. The part must be separate from all other assembled parts; otherwise, the assembly of parts meeting one of the preceding criteria would be prevented.

It should be pointed out that these criteria are to be applied without taking into account the general design or service requirements. For example, separate fasteners do not generally meet any of the preceding criteria and should always be considered for elimination. To be more specific, the designer considering the design of an automobile engine may feel that the bolts holding the cylinder head onto the engine block are necessary separate parts.

However, they could be eliminated by combining the cylinder head with the block—an approach that has proved practical in certain circumstances.

If applied properly, these criteria require the designer to consider means whereby the product can be simplified, and it is through this process that enormous improvements in assemblability and manufacturing costs are often achieved. However, it is also necessary to be able to quantify the effects of changes in design schemes. For this purpose, the DFA method incorporates a system for estimating the assembly cost which, together with estimates of parts cost, gives the designer the information needed to take appropriate

trade-off decisions.

### Classification Systems

The classification system for assembly processes is a systematic arrangement of part features that affect the acquisition, movement, orientation, insertion, and fastening of the part together with some operations that are not associated with specific parts such as turning the assembly over.

The complete classification system, its associated definitions, and the corresponding time standards is presented in tables in Figures 3.15 and 3.16. It can be seen that the classification

**MANUAL HANDLING-ESTIMATED TIMES (s)**

		Parts are easy to grasp and manipulate					Parts present handling difficulties (1)						
		Thickness >2 mm		Thickness ≤2 mm			Thickness >2 mm		Thickness ≤2 mm				
		Size >15 mm	6 mm ≤ size ≤15 mm	Size <6 mm	Size >6 mm	Size ≤6 mm	Size >15 mm	6 mm ≤ size ≤15 mm	Size <6 mm	Size >6 mm	Size ≤6 mm		
Key: <span style="border: 1px solid black; display: inline-block; width: 15px; height: 15px;"></span> One hand		0	1	2	3	4	5	6	7	8	9		
Parts can be grasped and manipulated by one hand without the aid of grasping tools	$(\alpha+\beta) < 360^\circ$	0	1.13	1.43	1.88	1.69	2.18	1.84	2.17	2.65	2.45	2.98	
	$360^\circ \leq (\alpha+\beta) < 540^\circ$	1	1.5	1.8	2.25	2.06	2.55	2.25	2.57	3.06	3	3.38	
	$540^\circ \leq (\alpha+\beta) < 720^\circ$	2	1.8	2.1	2.55	2.36	2.85	2.57	2.9	3.38	3.18	3.7	
	$(\alpha+\beta) = 720^\circ$	3	1.95	2.25	2.7	2.51	3	2.73	3.06	3.55	3.34	4	
Key: <span style="border: 1px solid black; display: inline-block; width: 15px; height: 15px;"></span> One hand with grasping aids		Parts need tweezers for grasping and manipulation											
		Parts can be manipulated without optical magnification					Parts require optical magnification for manipulation						
Parts can be grasped and manipulated by one hand but only with the use of grasping tools		Parts are easy to grasp and manipulate		Parts present handling difficulties (1)			Parts are easy to grasp and manipulate		Parts present handling difficulties (1)			Parts need standard tools other than tweezers	Parts need special tools for grasping and manipulation
		Thickness >0.25 mm	Thickness ≤0.25 mm	Thickness >0.25 mm	Thickness ≤0.25 mm	Thickness >0.25 mm	Thickness ≤0.25 mm	Thickness >0.25 mm	Thickness ≤0.25 mm				
		$0 \leq \beta \leq 180^\circ$	4	3.6	6.85	4.35	7.6	5.6	8.35	6.35	8.6	7	7
		$\beta = 360^\circ$	5	4	7.25	4.75	8	6	8.75	6.75	9	8	8
$\alpha \leq 180^\circ$	6	4.8	8.05	5.55	8.8	6.8	9.55	7.55	9.8	8	9		
$\alpha = 360^\circ$	7	5.1	8.35	5.85	9.1	7.1	9.55	7.85	10.1	9	10		
Key: <span style="border: 1px solid black; display: inline-block; width: 15px; height: 15px;"></span> Two hands for manipulation		Parts present no additional handling difficulties					Parts present additional handling difficulties (e.g. sticky, delicate, slippery, etc.) (1)						
		$\alpha \leq 180^\circ$		$\alpha = 360^\circ$			$\alpha \leq 180^\circ$		$\alpha = 360^\circ$				
Parts severely nest or tangle or are flexible but can be grasped and lifted by one hand (with the use of grasping tools if necessary) (2)		Size >15 mm	6 mm ≤ size ≤15 mm	Size <6 mm	Size >6 mm	Size ≤6 mm	Size >15 mm	6 mm ≤ size ≤15 mm	Size <6 mm	Size >6 mm	Size ≤6 mm		
		0	1	2	3	4	5	6	7	8	9		
8		4.1	4.5	5.1	5.6	6.75	5	5.25	5.85	6.35	7		
Key: <span style="border: 1px solid black; display: inline-block; width: 15px; height: 15px;"></span> Two hands or assistance required for large size		Parts can be handled by one person without mechanical assistance											
		Parts do not severely nest or tangle and are not flexible											
Two hands, two persons or mechanical assistance required for grasping and transporting parts		Part weight < 10 lb					Parts are heavy (>10 lb)						
		Parts are easy to grasp and manipulate		Parts present other handling difficulties (1)			Parts are easy to grasp and manipulate		Parts present other handling difficulties (1)			Parts severely nest or tangle or are flexible (2)	Two persons or mechanical assistance required for parts manipulation
		$\alpha \leq 180^\circ$	$\alpha = 360^\circ$	$\alpha \leq 180^\circ$	$\alpha = 360^\circ$	$\alpha \leq 180^\circ$	$\alpha = 360^\circ$	$\alpha \leq 180^\circ$	$\alpha = 360^\circ$				
		0	1	2	3	4	5	6	7	8	9		
9		2	3	2	3	3	4	4	5	7	9		

**Figure 3.16** Original classification system for part features affecting insertion and fastening. (Copyright

MANUAL INSERTION-ESTIMATED TIMES (s)

		Alter assembly no holding down required to maintain orientation and location (3)				Holding down required during subsequent processes to maintain orientation at location (3)				
		Easy to align and position during assembly (4)		Not easy to align or position during assembly		Easy to align and position during assembly (4)		Not easy to align or position during assembly		
		No resistance to insertion	Resistance to insertion (5)	No resistance to insertion	Resistance to insertion (5)	No resistance to insertion	Resistance to insertion (5)	No resistance to insertion	Resistance to insertion (5)	
		0	1	2	3	6	7	8	9	
Addition of any part (1) where neither the part itself nor any other part is finally secured immediately Part and associated tool (including hands) can easily reach the desired location		0	1.5	2.5	2.5	3.5	5.5	6.5	6.5	7.5
	Part and associated tool (including hands) cannot easily reach the desired location	1	4	5	5	6	8	9	9	10
	Due to obstructed access or restricted vision (2)	2	5.5	6.5	6.5	7.5	9.5	10.5	10.5	11.5
Addition of any part (1) where the part itself and/or other parts are being finally secured immediately Part and associated tool (including hands) can easily reach the desired location and the tool can be operated easily		3	2	5	4	5	6	7	8	9
	Part and associated tool (including hands) cannot easily reach desired location or tool cannot be operated easily	4	4.5	7.5	6.5	7.5	8.5	9.5	10.5	11.5
	Due to obstructed access or restricted vision (2)	5	6	9	8	9	10	11	12	13
Assembly processes where all solid parts are in place		9	4	7	5	12	7	8	12	12

		No screwing operation or plastic deformation immediately after insertion (snap/press fits, circlips, spire nuts, etc.)				Plastic deformation immediately after insertion				Screw tightening immediately after insertion	
		Plastic bending or torsion		Riveting or similar operation		Screw tightening immediately after insertion					
		Easy to align and position with no resistance to insertion (4)	Not easy to align or position during assembly and/or resistance to insertion (5)	Easy to align and position during assembly (4)	Not easy to align or position during assembly	Easy to align and position during assembly (4)	Not easy to align or position during assembly	Easy to align and position with no torsional resistance (4)	Not easy to align or position and/or torsional resistance (5)		
		0	1	2	3	4	5	6	7	8	9
Addition of any part (1) where neither the part itself nor any other part is finally secured immediately Part and associated tool (including hands) cannot easily reach the desired location		3	2	5	4	5	6	7	8	9	10
	Part and associated tool (including hands) cannot easily reach desired location or tool cannot be operated easily	4	4.5	7.5	6.5	7.5	8.5	9.5	10.5	11.5	12
	Due to obstructed access or restricted vision (2)	5	6	9	8	9	10	11	12	13	14

		Mechanical fastening processes (part(s) already in place but not secured immediately after insertion)				Non-mechanical fastening processes (part(s) already in place but not secured immediately after insertion)				Non-fastening processes	
		None or localized plastic deformation		Bulk plastic deformation (large proportion of part is plastically deformed during fastening)		Metallurgical processes		Chemical processes (e.g. adhesive bonding, etc.)		Manipulation of parts or sub-assembly (e.g. orienting, fitting or adjustment of part(s), etc.)	
		Bending or similar processes	Riveting or similar processes	Screw tightening or other processes	No additional material required (e.g. resistance, friction welding, etc.)	Soldering processes	Weld/braze processes	Chemical processes (e.g. adhesive bonding, etc.)	Manipulation of parts or sub-assembly (e.g. orienting, fitting or adjustment of part(s), etc.)	Other processes (e.g. liquid insertion, etc.)	
		0	1	2	3	4	5	6	7	8	9
Addition of any part (1) where neither the part itself nor any other part is finally secured immediately Part and associated tool (including hands) cannot easily reach the desired location		9	4	7	5	12	7	8	12	12	12
	Part and associated tool (including hands) cannot easily reach desired location or tool cannot be operated easily	4	4.5	7.5	6.5	7.5	8.5	9.5	10.5	11.5	12
	Due to obstructed access or restricted vision (2)	5	6	9	8	9	10	11	12	13	14

Key:  
 Part added but not secured

Part secured immediately

Separate operation



The portion of the classification system for manual insertion and fastening processes is concerned with the interaction between mating parts as they are assembled. Manual insertion and fastening consists of a finite variety of basic assembly tasks (peg-in-hole, screw, weld, rivet, press-fit, etc.) that are common to most manufactured products.

It can be seen that for each two-digit code number, an average time is given. Thus, we have a set of time standards that can be used to estimate manual assembly times. These time standards were obtained from numerous experiments, some of which will now be described.

### **Effect of Part Symmetry on Handling Time**

One of the principal geometrical design features that affects the time required to grasp and orient a part is its symmetry. Assembly operations always involve at least two component parts: the part to be inserted

and the part or assembly (receptacle) into which the part is inserted [15]. Orientation involves a proper alignment of the part to be inserted relative to the corresponding receptacle and can always be divided into two distinct operations: (1)

alignment of the axis of the part that corresponds to the axis of insertion, and (2) rotation of the part about this axis.

It is therefore convenient to define two kinds of symmetry for a part:

1. *Alpha Symmetry*: Depends on the angle through which a part must be rotated about an axis perpendicular to the axis of insertion to repeat its orientation.
2. *Beta Symmetry*: Depends on the angle through which a part must be rotated about the axis of insertion to repeat its orientation.

For example, a plain square prism that is to be inserted into a square hole would first have to be rotated about an axis perpendicular to the insertion axis. Since, with such a rotation, the prism repeats its orientation every  $180^\circ$ , it can be termed  $180^\circ$  alpha symmetry.

The square prism would then have to be rotated about the axis of insertion, and since the orientation of the prism about this axis would repeat every  $90^\circ$ , this implies a  $90^\circ$  beta symmetry.

However, if the square prism were to be inserted in a circular hole, it would have  $180^\circ$  alpha symmetry and  $0^\circ$  beta symmetry. Figure 3.17 gives examples of the symmetry of simple-shaped parts.

A variety of predetermined time standard systems are presently used to establish assembly times in the industry. In the development of these systems, several different approaches have been employed to determine relationships between the amount of rotation required to orient a part and the time required to perform that rotation. Two of the most commonly used systems are the methods time measurement (MTM) and work factor (WF) systems.

In the MTM system, the –maximum possible orientation is employed, which is one-half the beta rotational symmetry of a part mentioned above [16]. The effect of alpha symmetry is not considered in this system. For practical purposes, the MTM system classifies the maximum possible orientation into three groups, namely, (1) symmetric, (2) semisymmetric, and (3) nonsymmetric [3]; again, these terms refer only

to the beta symmetry of a part.

In the WF system, the symmetry of a part is classified by the ratio of the number of ways the part can be inserted to the number of ways the part can be grasped preparatory to insertion [17]. In the example of a square prism to be inserted into a square hole, one particular end first, it can be inserted in four ways out of the eight ways it could be suitably grasped. Hence, on the average, one-half of the parts grasped would require orientation, and this is defined in the WF system as a situation requiring 50% orientation [17]. Thus, in this system, account is taken of alpha symmetry, and some account is taken of beta symmetry. Unfortunately, these effects are combined in such a way that the classification can only be applied to a limited range of part shapes.

Numerous attempts were made to find a single parameter that would give a satisfactory relation between the symmetry of a part and the time required for orientation. It was found that the simplest and most useful parameter was the sum of the alpha and beta symmetries [5]. This parameter, which would be termed the total angle of symmetry, is therefore given by

$$\text{Total angle of symmetry} = \alpha + \beta. \quad (3.2)$$

The effect of the total angle of symmetry on the time required to handle (grasp, move, orient, and place) a part is shown in Figure 3.18. In addition, the shaded areas indicate the values of the total angle of symmetry that cannot exist. It is evident from these results that the symmetry of a part can be conveniently classified into five groups. However, the first group, which represents a sphere, is not generally of practical interest; therefore, four groups are suggested that are employed in the coding system for part handling (Figure 3.15). A comparison of these experimental results with the MTM and WF orientation parameters show that these parameters do not account properly for the symmetry of a part [5].

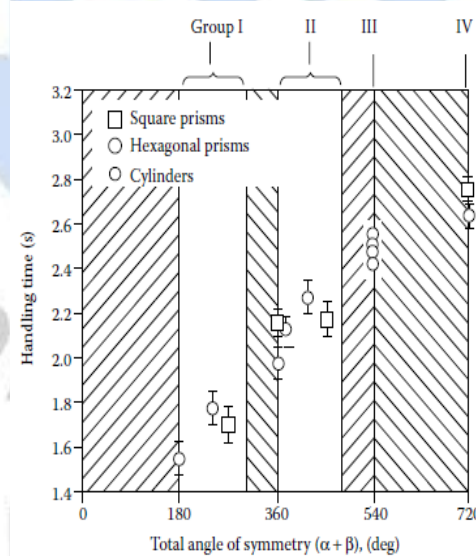

**Figure 3.18** Effect of symmetry on the time required for part handling. Times are average for two individuals and shaded areas represent nonexistent values of the total angle of symmetry.

### Specific Design Rules

A number of DFM rules for design, more specific than the preceding guidelines, have



been developed. 22

1. Space holes in machined, cast, molded, or stamped parts so they can be made in one operation without tooling weakness. This means that there is a limit on how close holes may be spaced due to strength in the thin section between holes.
2. Avoid generalized statements on drawings, like –polish this surfacell or –toolmarks not permitted,|| which are difficult for manufacturing personnel to interpret. Notes on engineering drawings must be specific and unambiguous.
3. Dimensions should be made from specific surfaces or points on the part, not from points in space. This greatly facilitates the making of gages and fixtures. The use of GD&T methods makes this point moot.
4. Dimensions should all be from a single datum surface rather than from a variety of points to avoid overlap of tolerances.
5. The design should aim for minimum weight consistent with strength and stiffness requirements. While material costs are minimized by this criterion, there also will usually be a reduction in labor and tooling costs.
6. Whenever possible, design to use general-purpose tooling rather than special dies, form cutters, and similar tools. An exception is high-volume production where special tooling may be more cost-effective.
7. Use generous fillets and radii on castings and on molded, formed, and machined parts.
8. Parts should be designed so that as many operations as possible can be performed without requiring repositioning. This promotes accuracy and minimizes handling.

It is valuable to have manufacturing engineers and specialists involved in design decision making so that these guidelines and others they bring can inform the process.

#### **MACHINABILITY –EASE OF MATERIAL REMOVAL FACTORS :**

- 1) Work piece material
- 2) Tool material and geometry
- 3) Type of machining
- 4) Operating conditions

DFM guide lines for machining:

- 1) Minimize area of machining
- 2) Utilize standard components as much as possible
- 4) Preshape the work piece –use casting , forging , welding etc
- 5) Use standard preshaped work piecees
- 6) Employ standard machined features raw materials

- Choosing to reduce cost
- Use raw material in standard forms component design

## General

1. Design component so that it can be machined on one machine tool
2. Design component so that machining is not required on unexposed Surfaces of the work pieces when the component is gripped in the Work holding device
3. Avoid machined features which the company cannot handle
4. Design component is rigid when gripped in work holding device
5. Verify that when features are to be machined , the tool , tool holder , Work and work holding device , will not interface with each other
6. Ensure that auxiliary holes or main bores are cylindrical and Have l/d ratios that make it possible to machine them with standard Drills or boring tools
7. Ensure that auxiliary holes are parallel or normal to the work piece Axes or reference surface and related by a drilling pattern
8. Ensure ends of blind holes are conical and thread in tapped blind hole does not continue till end
9. Avoid bent holes

### Rotational Components:

- 1) Cylindrical surfaces concentric , plane surfaces normal to the components axis
- 2) Diameter of external features increase from the exposed face of the work piece
- 3) Diameter of internal features decrease from the exposed face of the work piece
- 4) Internal corners –radii equal to the radius of the standard rounded tool corner
- 5) Avoid internal features for long components
- 6) Avoid components with very large or very small L/D Ratios

### Non –Rotational Components

1. Provide a base for work holding and reference
2. Exposed surfaces consist of a series of mutually  $\perp$  r plane surfaces and normal to base ensure that internal corners normal to the base
3. Radius equal to a standard tool radius ensure that for machined pockets , the internal corners normal to the base have as large a radius as possible

4. Restrict plane surface machining (slots, grooves etc) to one surface of the component
5. Avoid cylindrical bores in long components
6. Avoid machined surfaces on long components by using work material performed to the cross section required
7. Avoid extremely long or extremely thin components
8. Ensure that in flat or cubic components, main bores are normal to the base and consist of cylindrical surfaces decreasing in diameter from the exposed face of the work piece
9. Avoid blind bores in large cubic components

**ASSEMBLY:**

- 1) Ensure that assembly is possible
- 2) Ensure that each operating machined surface on a component has a corresponding machined surface on mating component
- 3) Ensure that internal corners do not interface with a corresponding external

**Accuracy and Surface finish:**

- 1) Specify widest tolerances and roughest surface that will give the required performance for operating surfaces
- 2) Ensure that surfaces to be finish ground are raised and never intersect to form internal corners.

**Guidelines:**

1. Tolerances 0.127 to 0.25 mm can be readily obtained
  2. Tolerances 0.025 to 0.05 mm are slightly more difficult to obtain and can increase production cost
  3. Tolerances 0.0127 mm or smaller require good equipment and skilled operators and add significantly to production costs
- surface finish : 1µm arithmetical mean and better will require separate.

EG: TURNING OPERATION

$$R_a = 0.0321 f^2/r\epsilon$$

Where  $R_a$  = Arithmetical mean surface roughness

$f \rightarrow$  feed

$r\epsilon \rightarrow$  tool corner radius

Machining time

$$t_m = l_w / f_{nw}$$

$l_w \rightarrow$  length of work piece

$n_w \rightarrow$  rotational speed of work piece

Process Surface roughness (Typical)  $\mu\text{m}$

SAW	25-6.3
TURN ,MILL,BORE	6.3-3.2
DRILL	5.3-2.4
REAM	4.0-2.0
GRIND	2.4-0.5
HONING0.	5-0.18
LAP,POLISH0.	3-0.025

$$T_m = 0.18 l_w / [ n_w (R_a \cdot r\epsilon)^{0.5} ]$$

Machining time inversely proportional to surface finish machining cost increases with lesser surface roughness

Designing for machining ease

Machinability

- 1) Hardness  $\rightarrow$  steels below 300 HB are easy to machine
- 2) Microstructure  $\rightarrow$  High carbon steels  $\rightarrow$  Tool wear Cast Iron  $\rightarrow$  good finish (due to free graphite)
- 3) Free cutting properties

MnS inclusion in steel  $\rightarrow$  free machining

Pb in brass  $\rightarrow$  free machining

- 4) Ductility  $\rightarrow$  Discontinuous or powdery

Chip show high machinability

Continuous chips –harm to operator

Machinability index or rating Metal removed rate ratio

**Factors for machining ease:**

1. Reduce amount of machining (Tolerances for mating suspects)
2. Convenient and reliable locating surfaces to setup work piece
3. Sufficient rigidity of work piece
4. Provision for advancing of cutting tool
5. Clearance recesses
6. Several work piece can be set up to be machined simultaneously
7. External surfaces of revolution upset heads , flanges , and shoulders should be extensively applied to reduce machining and to save metal
8. Retaining centre holes on the finished components
9. Elements of shank design should be unified
10. Spherical convex surfaced
11.
  - a) Through holes are to be used where ever possible
  - b) Holes should not be located closer to a certain minimum distance from an adjacent wall of the part
  - c) Centre distances of holes to be specified considering the possibility of using multi spindle drilling heads
  - d) Holes to be drilled should have their top and bottom surface square to the hole axis to prevent drill breakage
  - e) Several holes along same axis
  - f) In drilling holes at the bottom of a slot, their diashould be less by 0.5-1 mm than slot width
  - g) In stepped holes , maximum accuracy should be specified for the through step
  - h) Concave spherical surfaces should have through hole or blind hole
  - i) Avoid recesses
- 12)
  - a. Threads Entering chamfer on threaded holes
  - b. No. of incomplete threads in a blind hole with no recess should be equal to three for Grey Iron Casting and five for steel parts
  - c) A neck at the end of a thread is not required for milled threads
  - d) Preferred thread standards should pertain
  - e) Flat surfaces

- Uniform and impact less chip removal



- Size of machined flat surface should ensure using of standard milling cutters

### Goals of design for Machining

1. Reduce machining time
2. Reduce material costs
3. Reduce tooling costs
4. Reduce setup cost

### Examples of Design for machining

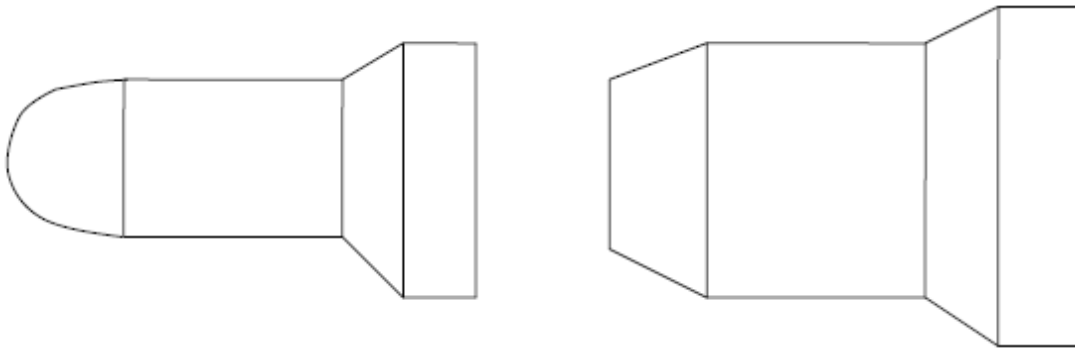

Bad design 2 different techniques required

Better design Profiles similar

Poor design

Better design

Sharp inside  
Corners difficult to machine

