



DATA STRUCTURES

Course code: AHSB03

II B. Tech II semester

Regulation: IARE R-18

BY

Ms. Y Harika Devi

Mr. U Shivaji

DEPARTMENT OF ELECTRONICS AND ELECTRICAL ENGINEERING

INSTITUTE OF AERONAUTICAL ENGINEERING

(Autonomous)

DUNDIGAL, HYDERABAD - 500 043

CO's

Course outcomes

- | | |
|-----|---|
| CO1 | Learn the basic techniques of algorithm analysis. |
| CO2 | Demonstrate searching and sorting algorithms and analyze their time complexities. |
| CO3 | Implement linear data structures viz. stack, queue and linked list. |
| CO4 | Demonstrate non-linear data structures viz. tree and graph traversal algorithms. |
| CO5 | Study and choose appropriate data structure to solve problems in real world. |

MODULE- I
INTRODUCTION TO DATA
STRUCTURES, SEARCHING AND
SORTING

CLOs	Course Learning Outcome
CLO1	Understand algorithms and data structures in terms of time and space complexity of basic operations
CLO2	Analyze a given problem; choose an appropriate data structure and an algorithm to solve the problem.
CLO3	Choose a suitable algorithm to organize the data in ascending or descending order.
CLO4	Understand the difference between iterative and recursion approaches to solve problems.

CLOs	Course Learning Outcome
CLO5	Explore an algorithm to find the location of an element in a given list.
CLO6	Understand the usage of divide and conquer strategy in searching and sorting applications.
CLO7	Compare the time complexities of various searching and sorting algorithms.

- **Introduction to Data Structures**
- **Classification and Operations on Data Structures**
- **Searching Techniques - Linear, Binary**
- **Sorting Techniques- Bubble, Selection and Insertion sort**
- **Comparison of Sorting Algorithms**

- A data structure is a way of storing data in a computer so that it can be used efficiently and it will allow the most efficient algorithm to be used.
- A data structure should be seen as a logical concept that must address two fundamental concerns.
 - I. First, how the data will be stored, and
 - II. Second, what operations will be performed on it.

Classification of Data Structures

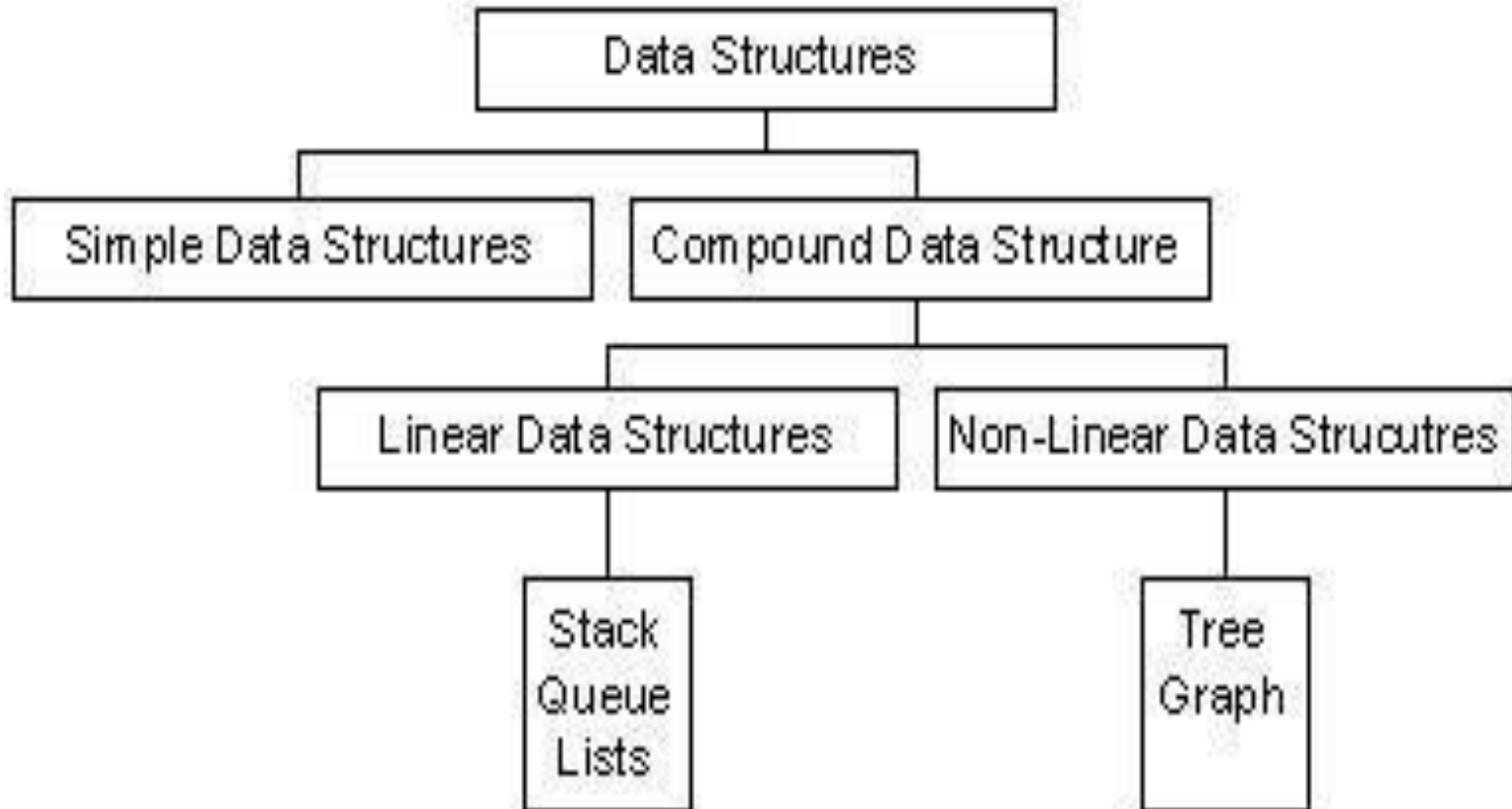

Simple and Compound Data Structures



- **Simple Data Structure:** Simple data structure can be constructed with the help of primitive data structure. A primitive data structure used to represent the standard data types of any one of the computer languages. Variables, arrays, pointers, structures, unions, etc. are examples of primitive data structures.
- **Compound Data structure:** Compound data structure can be constructed with the help of any one of the primitive data structure and it is having a specific functionality. It can be designed by user. It can be classified as

- **Linear Data Structure:**
- **Linear data structures can be constructed as a continuous arrangement of data elements in the memory. It can be constructed by using array data type. In the linear Data Structures the relationship of adjacency is maintained between the data elements.**
- **Non-Linear Data Structure:**
Non-linear data structures can be constructed as a collection of randomly distributed set of data item joined together by using a special pointer (tag). In non-linear Data structure the relationship of adjacency is not maintained between the data items.

- i. Add an element**
- ii. Delete an element**
- iii. Traverse**
- iv. Sort the list of elements**
- v. Search for a data element**

Algorithm Definition



- **An Algorithm may be defined as a finite sequence of instructions each of which has a clear meaning and can be performed with a finite amount of effort in a finite length of time.**
- **The word algorithm originates from the Arabic word Algorism which is linked to the name of the Arabic Mathematician Al Khwarizmi.**
- **Al Khwarizmi is considered to be the first algorithm designer for adding numbers.**

Structure of an Algorithm

- **An algorithm has the following structure:**
 - **Input Step**
 - **Assignment Step**
 - **Decision Step**
 - **Repetitive Step**
 - **Output Step**

Properties of an Algorithm



- **Finiteness:-** An algorithm must terminate after finite number of steps.
- **Definiteness:-** The steps of the algorithm must be precisely defined.
- **Generality:-** An algorithm must be generic enough to solve all problems of a particular class.
- **Effectiveness:-** The operations of the algorithm must be basic enough to be put down on pencil and paper.
- **Input-Output:-** The algorithm must have certain initial and precise inputs, and outputs that may be generated both at its intermediate and final steps

- **The performances of algorithms can be measured on the scales of Time and Space.**
- **The Time Complexity of an algorithm or a program is a function of the running time of the algorithm or a program.**
- **The Space Complexity of an algorithm or a program is a function of the space needed by the algorithm or program to run to completion.**

- **The Time Complexity of an algorithm can be computed either by an**
 - **Empirical or Posteriori Testing**
 - **Theoretical or Apriori Approach**
- **The Empirical or Posteriori Testing approach calls for implementing the complete algorithm and executes them on a computer for various instances of the problem.**
- **The Theoretical or Apriori Approach calls for mathematically determining the resources such as time and space needed by the algorithm, as a function of parameter related to the instances of the problem considered.**

- **Apriori analysis computed the efficiency of the program as a function of the total frequency count of the statements comprising the program.**

- **Example:**

Let us estimate the frequency count of the statement $x = x+2$ occurring in the following three program segments A, B and C.

Total Frequency Count of Program

Segment A

- Program Statements

.....

$x = x + 2$

.....

Total Frequency Count

- Frequency Count

1

1

Time Complexity of Program Segment A is $O(1)$.

Total Frequency Count of Program



Segment B

- Program Statements

```
.....  
for k = 1 to n do  
    x = x+ 2;  
end  
.....
```

Total Frequency Count

- Frequency Count

```
(n+1)  
n  
n  
.....  
3n+1
```

Time Complexity

Complexity	Notation	Description
Constant	$O(1)$	Constant number of operations, not depending on the input data size.
Logarithmic	$O(\log n)$	Number of operations proportional of $\log(n)$ where n is the size of the input data.
Linear	$O(n)$	Number of operations proportional to the input data size.
Quadratic	$O(n^2)$	Number of operations proportional to the square of the size of the input data.
Cubic	$O(n^3)$	Number of operations proportional to the cube of the size of the input data.
Exponential	$O(2^n)$	Exponential number of operations, fast growing.
	$O(k^n)$	

Time Complexities of various Algorithms

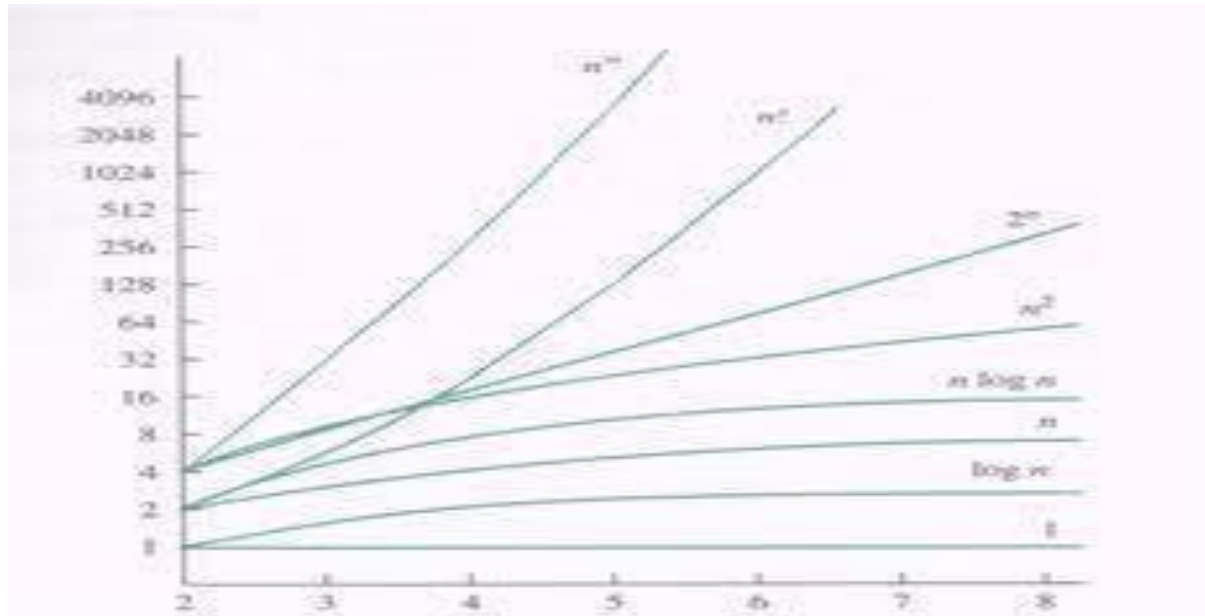

Searching Methods



- **Search:** A search algorithm is a method of locating a specific item of information in a larger collection of data.
- There are two primary algorithms used for searching the contents of an array:
 1. **Linear or Sequential Search**
 2. **Binary Search**

- **Begins search at first item in list, continues searching sequentially(item by item) through list, until desired item(key) is found, or until end of list is reached.**

Also called sequential or serial search.

- **Obviously not an efficient method for searching ordered lists like phone directory(which is ordered alphabetically).**
- **Advantages**
 1. **Algorithm is simple.**
 2. **List need not be ordered in any particular way.**
- **Time Complexity of Linear Search is $O(n)$.**

Recursive Linear Search Algorithm



```
def linear_Search(l,key,index=0):  
    if l:  
        if l[0]==key:  
            return index  
        s=linear_Search(l[1:],key,(index+1))  
        if s is not false:  
            return s  
  
    return false
```

Binary Search



Binary search uses a recursive method to search an array to find a specified value

The array must be a sorted array:

$a[0] \leq a[1] \leq a[2] \leq \dots \leq a[\text{finalIndex}]$

If the value is found, its index is returned

If the value is not found, -1 is returned

Note: Each execution of the recursive method reduces the search space by about a half

Binary Search



An algorithm to solve this task looks at the middle of the array or array segment first

If the value looked for is smaller than the value in the middle of the array

Then the second half of the array or array segment can be ignored

This strategy is then applied to the first half of the array or array segment

If the value looked for is larger than the value in the middle of the array or array segment

Then the first half of the array or array segment can be ignored

This strategy is then applied to the second half of the array or array segment

If the value looked for is at the middle of the array or array segment, then it has been found

If the entire array (or array segment) has been searched in this way without finding the value, then it is not in the array

- **First Level Considerations**
- **To sort list of n elements in ascending order**
 - Pass 1 :make n th element the largest**
 - Pass 2 :if needed make $n-1$ th element the 2nd largest**
 - Pass 3 :if needed make $n-2$ th element the 3rd largest**
 - Pass $n-2$: if needed make 3rd $n-(n-3)$ th element the $(n-2)$ th largest**
 - Pass $n-1$:if needed make 2nd $n-(n-2)$ th element the $(n-1)$ th largest**
- **Maximum number of passes is $(n-1)$.**

Bubble Sort



- **Pass 1: Make nth element the largest. Compare each successive pair of elements beginning with 1st 2nd and ending with n-1th nth and swap the elements if necessary.**
- **Pass 2 : Make n-1th element the 2nd largest. Compare each successive pair of elements beginning with 1st 2nd and ending with n-2th n-1th and swap the elements if necessary**

Pass $n-1$: Make 2nd $n-(n-2)$ th element the $(n-1)$ th largest.

Compare each successive pair of elements beginning with 1st 2nd and ending with $n-(n-1)$ th $n-(n-2)$ th 1st 2nd and swap the elements if necessary.

List is sorted when either of the following occurs No swapping involved in any pass

Pass $n-1$: the last pass has been executed

Bubble Sort Example

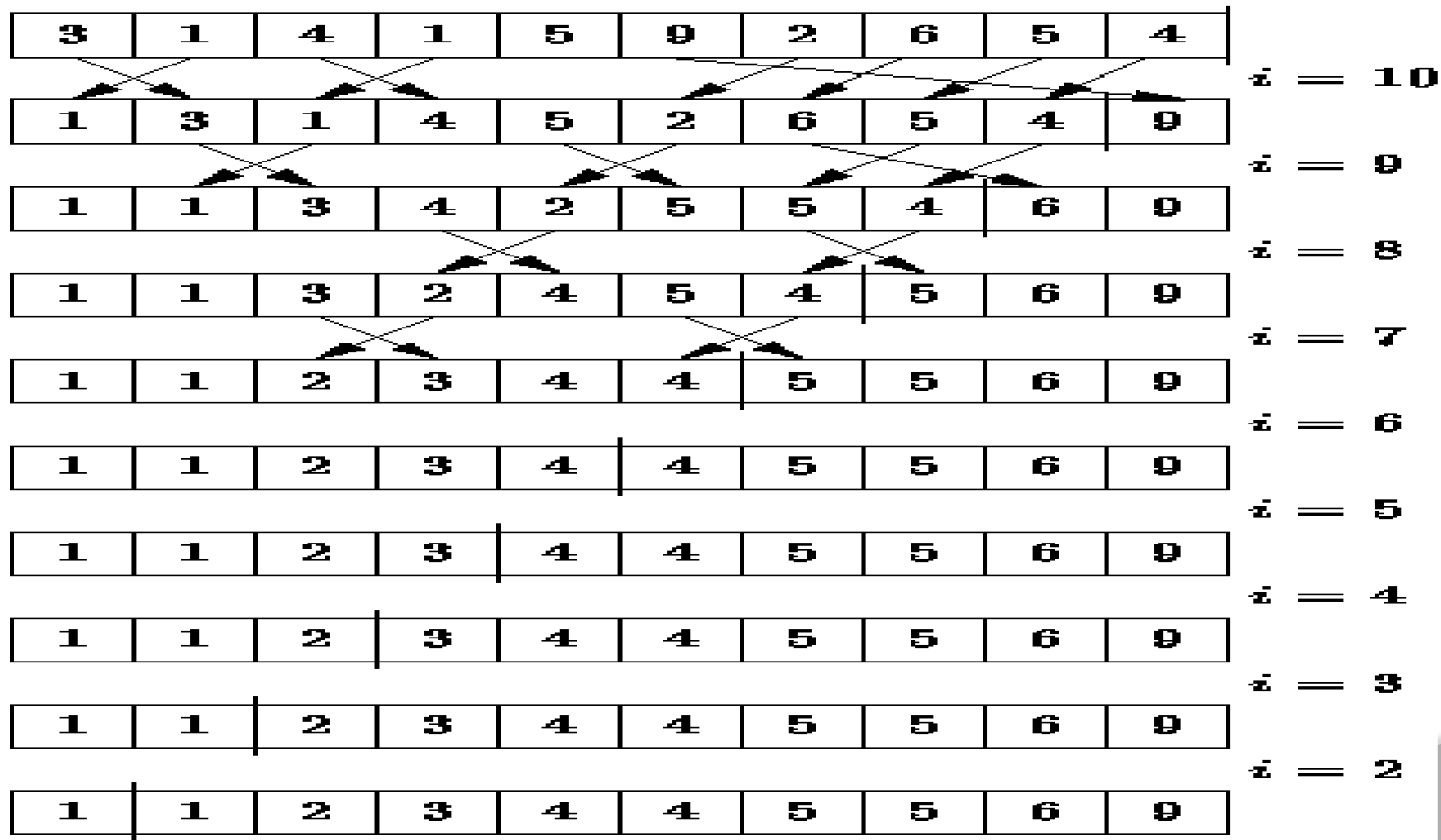

Selection Sort



- To sort list of n elements in ascending order
- Pass 1: make 1st element the smallest
- Pass 2: make 2nd element the 2nd smallest
- Pass 3: make 3rd element the 3rd smallest
- Pass $n-2$: make $(n-2)^{\text{th}}$ element the $(n- 2)^{\text{th}}$ smallest
- Pass $n-1$: make $(n-1)^{\text{th}}$ element the $(n- 1)^{\text{th}}$ smallest
- Number of passes is $(n-1)$.

Second Level Considerations

- **Pass 1: Make 1st element the smallest**
Examine list from 1st to last element locate element with smallest value and swap it with the 1st element where appropriate .
- **Pass 2: Make 2nd element the 2nd smallest**
Examine list from 2nd to last element locate element with smallest value and swap it with the 2nd element where appropriate.
- **Pass n-1: Make $(n-1)^{\text{th}}$ element the $(n-1)^{\text{th}}$ smallest**
Examine list from $(n-1)^{\text{th}}$ to last element locate element with smallest value and swap it with the n-1th element where appropriate.

Selection Sort Example

Scan right starting with 3.
1 is the smallest. Exchange 1 and 3.



Scan right starting with 9.
2 is the smallest. Exchange 9 and 2.



Scan right starting with 6.
3 is the smallest. Exchange 6 and 3.



Scan right starting with 6.
6 is the smallest. Exchange 6 and 6.

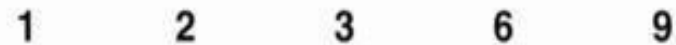



First Level Considerations

To sort list of n items (stored as 1D array) in ascending order

- **NOTE: 1-element sub-array (1st) is always sorted**
- **Pass 1: make 2-element sub-array (1st 2nd) sorted**
- **Pass 2 :make 3-element sub-array (1st 2nd 3rd) sorted**
- **Pass 3 :make 4-element sub-array (1st 4th) sorted**
- **Pass $n-2$: make $n-1$ -element sub-array (1st $(n-1)$ th) sorted**
- **Pass $n-1$: make entire n -element array (1st n th) sorted**
- **Number of passes is $(n-1)$**

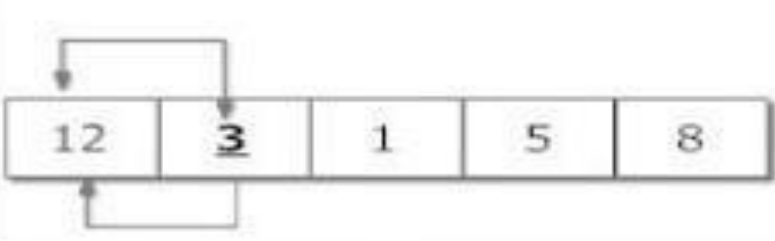
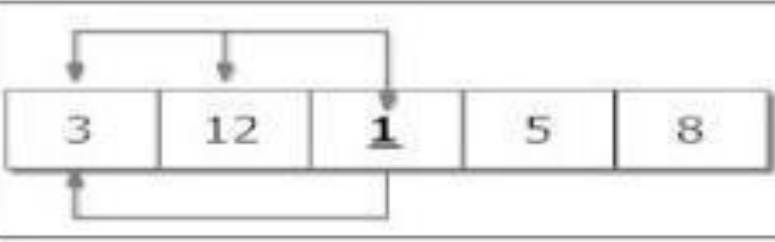
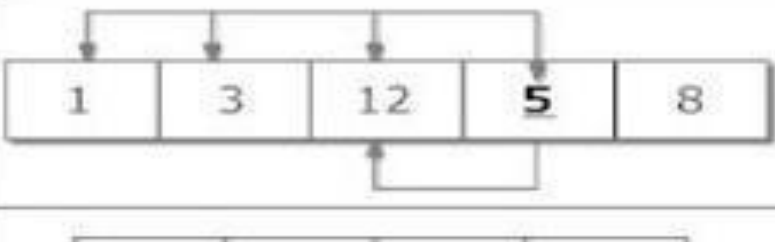
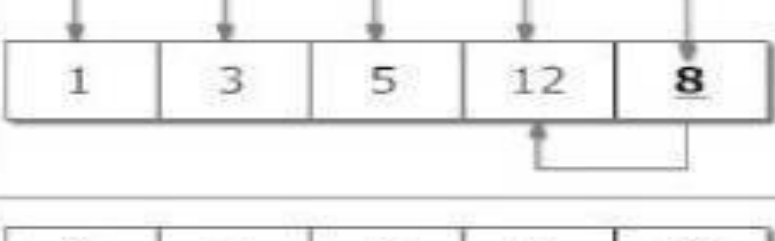
Insertion Sort

Step 1		<p>Checking second element of array with element before it and inserting it in proper position. In this case, 3 is inserted in position of 12.</p>
Step 2		<p>Checking third element of array with elements before it and inserting it in proper position. In this case, 1 is inserted in position of 3.</p>
Step 3		<p>Checking fourth element of array with elements before it and inserting it in proper position. In this case, 5 is inserted in position of 12.</p>
Step 4		<p>Checking fifth element of array with elements before it and inserting it in proper position. In this case, 8 is inserted in position of 12.</p>
		<p>Sorted Array in Ascending Order</p>

Comparison of Sorting Algorithms

Algorithm	Data Structure	Time Complexity		
Bubble Sort	Array	$O(n)$	$O(n^2)$	$O(n^2)$
Insertion Sort	Array	$O(n)$	$O(n^2)$	$O(n^2)$
Select Sort	Array	$O(n^2)$	$O(n^2)$	$O(n^2)$

MODULE – II
LINEAR DATA STRUCTURES

Running Course Learning Outcomes

The course will enable the students to:

CLO 5

Implementation of stack and queues using an underlying array.

CLO 6

Understand application of stacks in arithmetic expression conversion and evaluation.

CLO 7

Understand working of circular queues and double ended queue.

- **Stacks - Primitive Operations**
- **Implementation of stacks using arrays**
- **Applications of Stack**
- **arithmetic expression conversion and evaluation**
- **Queues - Primitive Operations**
- **Implementation of queues using Arrays**
- **Applications of Linear Queue**
- **Circular Queue**
- **Double Ended Queue (Deque)**

Stacks

- **A stack is a list of elements in which an element may be inserted or deleted only at one end, called the top of the stack.**
- **The elements are removed from a stack in the reverse order of that in which they were inserted into the stack.**
- **Stack is also known as a LIFO (Last in First out) list or Push down list.**

Basic Stack Operations

- PUSH:** It is the term used to insert an element into a stack.

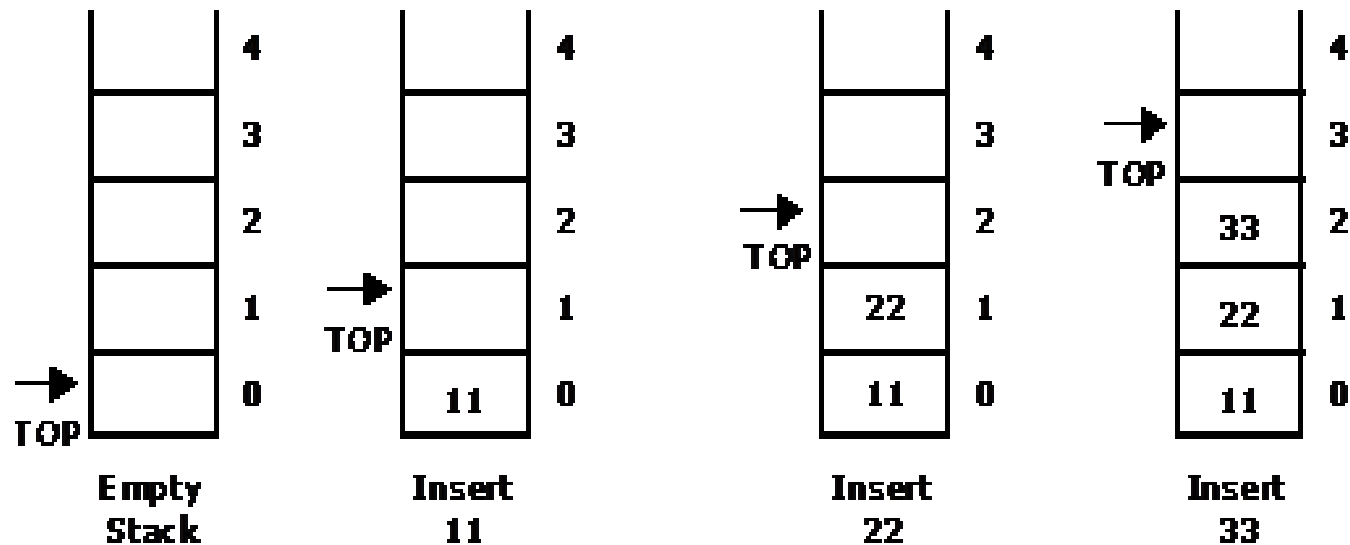

PUSH operations on stack

Basic Stack Operations

POP: It is the term used to delete an element from a stack.

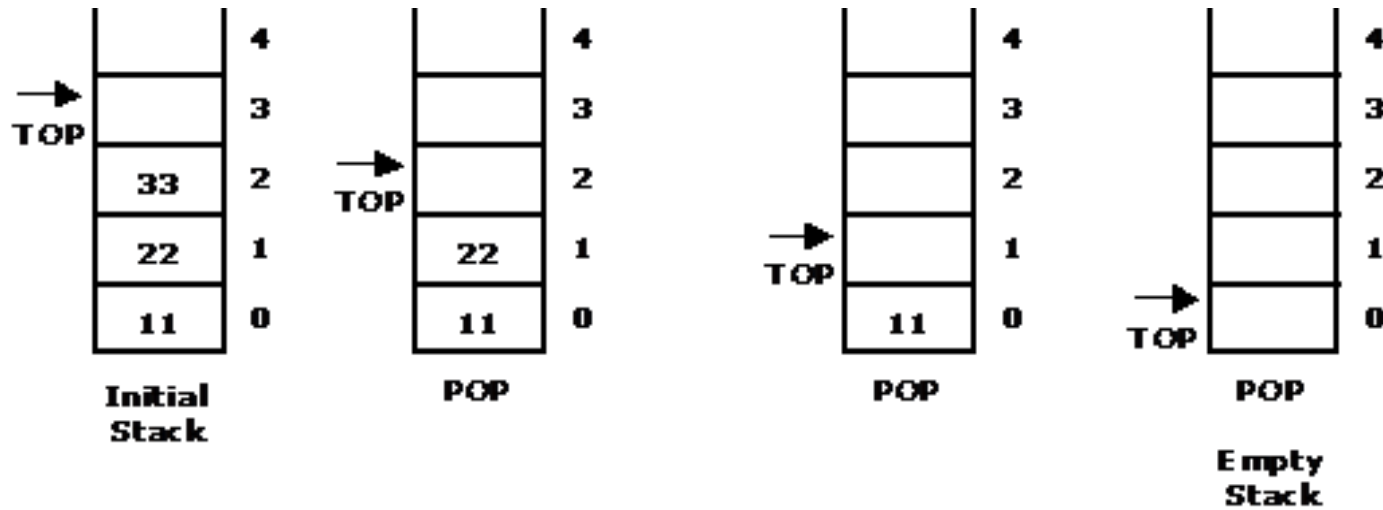

POP operation from a stack

Standard Error Messages in Stack

- **Two standard error messages of stack are**
 - **Stack Overflow:** If we attempt to add new element beyond the maximum size, we will encounter a stack overflow condition.
 - **Stack Underflow:** If we attempt to remove elements beyond the base of the stack, we will encounter a stack underflow condition.

Stack Operations

- **PUSH (STACK, TOP, MAXSTR, ITEM):** This procedure pushes an ITEM onto a stack
 1. If $TOP = MAXSIZE$, then Print: **OVERFLOW**, and Return.
 2. Set $TOP := TOP + 1$ [Increases TOP by 1]
 3. Set $STACK [TOP] := ITEM$. [Insert ITEM in TOP position]
 4. Return
- **POP (STACK, TOP, ITEM):** This procedure deletes the top element of STACK and assign it to the variable ITEM
 1. If $TOP = 0$, then Print: **UNDERFLOW**, and Return.
 2. Set $ITEM := STACK[TOP]$
 3. Set $TOP := TOP - 1$ [Decreases TOP by 1]
 4. Return

Applications of Stack



- **Converting algebraic expressions from one form to another. E.g. Infix to Postfix, Infix to Prefix, Prefix to Infix, Prefix to Postfix, Postfix to Infix and Postfix to prefix.**
- **Evaluation of Postfix expression.**
- **Parenthesis Balancing in Compilers.**
- **Depth First Search Traversal of Graph.**
- **Recursive Applications.**

Arithmetic Expression

- Infix: It is the form of an arithmetic expression in which we fix (place) the arithmetic operator in between the two operands. E.g.: $(A + B) * (C - D)$
- Prefix: It is the form of an arithmetic notation in which we fix (place) the arithmetic operator before (pre) its two operands. The prefix notation is called as polish notation. E.g.: $* + A B - C D$
- Postfix: It is the form of an arithmetic expression in which we fix (place) the arithmetic operator after (post) its two operands. The postfix notation is called as suffix notation and is also referred to reverse polish notation. E.g: $A B + C D - *$

Conversion from Infix to Postfix

Convert the following infix expression $A + B * C - D / E * H$ into its equivalent postfix expression.

Symbol	Postfix string	Stack	Remarks
A	A		
+	A	+	
B	AB	+	
*	AB	+ *	
C	ABC	-	
-	ABC* +	-	
D	ABC* + D	-	
/	ABC* + D	- /	
E	ABC* + DE	- /	
*	ABC* + DE/	- *	
H	ABC* + DE/H	- *	
End of string	ABC* + DE/H* -		The input is now empty. Pop the output symbols from the stack until it is empty.

Evaluation of Postfix Expression

Postfix expression: 6 5 2 3 + 8 * + 3 + *

Symbol	Operand 1	Operand 2	Value	Stack	Remarks
6				6	
5				6, 5	
2				6, 5, 2	
3				6, 5, 2, 3	The first four symbols are placed on the stack
+	2	3	5	6, 5, 5	Next a '+' is read, so 3 and 2 are popped from the stack and their sum 5, is pushed
8	2	3	5	6, 5, 5, 8	Next 8 is pushed
*	5	8	40	6, 5, 40	Now a '*' is seen, so 8 and 5 are popped as $8 * 5 = 40$ is pushed
+	5	40	45	6, 45	Next, a '+' is seen, so 40 and 5 are popped and $40 + 5 = 45$ is pushed
3	5	40	45	6, 45, 3	Now, 3 is pushed
+	45	3	48	6, 48	Next, '+' pops 3 and 45 and pushes $45 + 3 = 48$ is pushed
*	6	48	288	288	Finally, a '*' is seen and 48 and 6 are popped, the result $6 * 48 = 288$ is pushed

Queue

- A queue is a data structure where items are inserted at one end called the rear and deleted at the other end called the front.
- Another name for a queue is —FIFO|| or—First-in-first-out|| list.
- Operations of a Queue:
 - enqueue: which inserts an element at the end of the queue.
 - dequeue: which deletes an element at the front of the queue.

Representation of Queue

Initially the queue is empty.

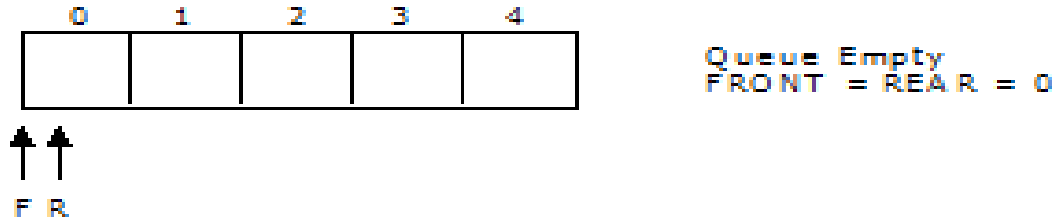

Now, insert 11 to the queue. Then queue status will be:

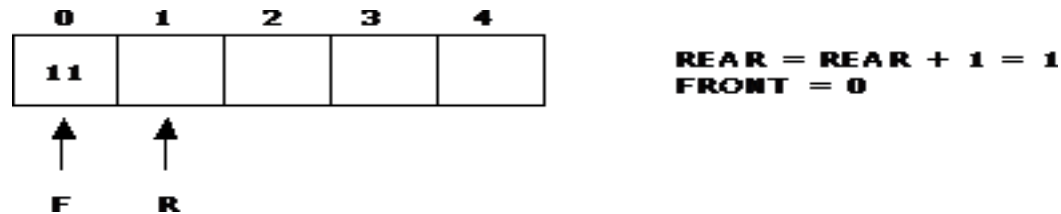

Next, insert 22 to the queue. Then the queue status is:

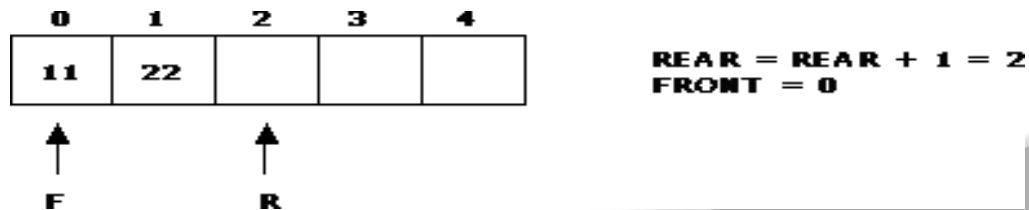

Representation of Queue

Now, delete an element 11.

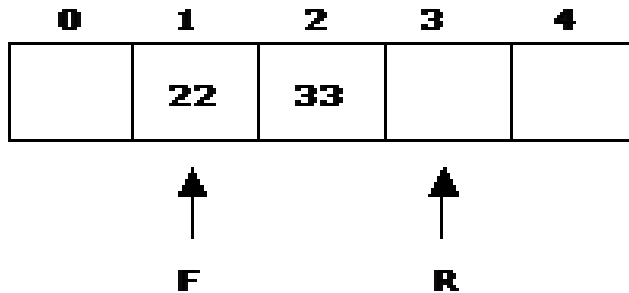

REAR = 3
FRONT = FRONT + 1 = 1

Next insert another element, say 66 to the queue.

We cannot insert 66 to the queue as it signals queue is full. The queue status is as follows:

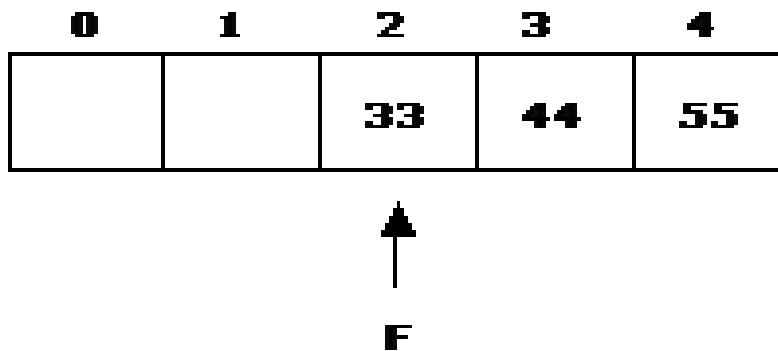

REAR = 5
FRONT = 2

Queue Operations using Array

- **Various operations of Queue are:**
 - **insertQ():** inserts an element at the end of queue Q.
 - **deleteQ():** deletes the first element of Q.
 - **displayQ():** displays the elements in the queue.
- **There are two problems associated with linear queue. They are:**
 - **Time consuming:** linear time to be spent in shifting the elements to the beginning of the queue.
 - **Signaling queuefull:** even if the queue is having vacant position

Applications of Queue

- It is used to schedule the jobs to be processed by the CPU.
- When multiple users send print jobs to a printer, each printing job is kept in the printing queue. Then the printer prints those jobs according to first in first out (FIFO) basis.
- Breadth first search uses a queue data structure to find an element from a graph.

Circular Queue

- A circular queue is one in which the insertion of new element is done at the very first location of the queue if the last location of the queue is full.
- Suppose if we have a Queue of n elements then after adding the element at the last index i.e. $(n-1)$ th , as queue is starting with 0 index, the next element will be inserted at the very first location of the queue which was not possible in the simple linear queue.

Circular Queue operations

- **The Basic Operations of a circular queue are**
 - **InsertionCQ:** Inserting an element into a circular queue results in $\text{Rear} = (\text{Rear} + 1) \% \text{MAX}$, where MAX is the maximum size of the array.
 - **DeletionCQ :** Deleting an element from a circular queue results in $\text{Front} = (\text{Front} + 1) \% \text{MAX}$, where MAX is the maximum size of the array.
 - **TraversCQ:** Displaying the elements of a circular Queue.
- **Circular Queue Empty: Front=Rear=0**

Circular Queue Representation Using Arrays

Let us consider a circular queue, which can hold maximum (MAX) of six elements. Initially the queue is empty.

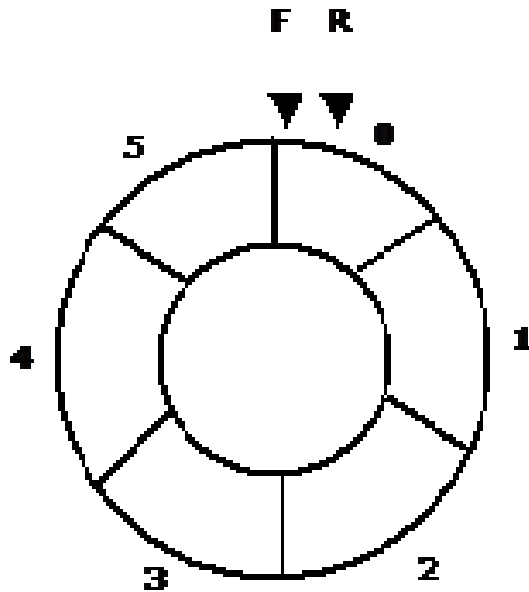

Circular Queue

Queue Empty
MAX = 6
FRONT = REAR = 0
COUNT = 0

Insertion and Deletion operations on a Circular Queue

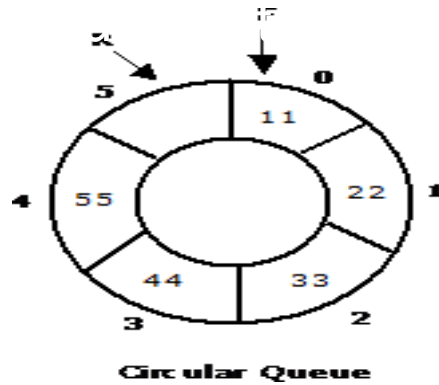

FRONT = 0, REAR = 5
REAR = REAR % 6 = 5
COUNT = 5

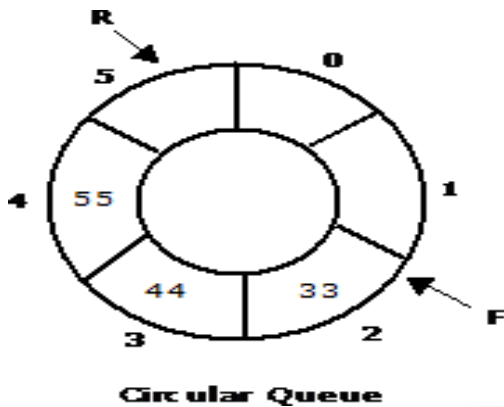

FRONT = (FRONT + 1) % 6 = 2
REAR = 5
COUNT = COUNT - 1 = 3

Insertion and Deletion operations on a Circular Queue

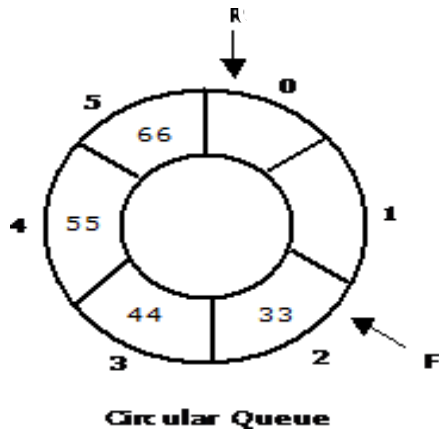

FRONT = 2
REAR = (REAR + 1) % 6 = 0
COUNT = COUNT + 1 = 4

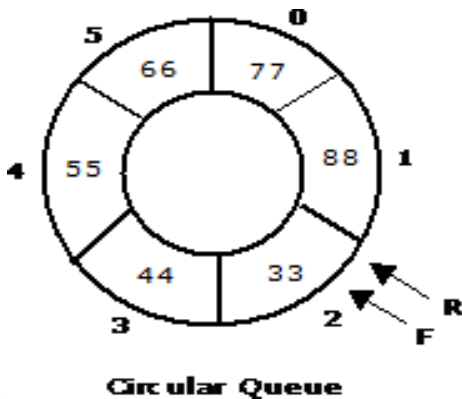

FRONT = 2, REAR = 2
REAR = REAR % 6 = 2
COUNT = 6

Double Ended Queue (DEQUE)

- It is a special queue like data structure that supports insertion and deletion at both the front and the rear of the queue.
- Such an extension of a queue is called a double-ended queue, or deque, which is usually pronounced "deck" to avoid confusion with the dequeue method of the regular queue, which is pronounced like the abbreviation "D.Q."
- It is also often called a head-tail linked list.

DEQUE Representation using arrays

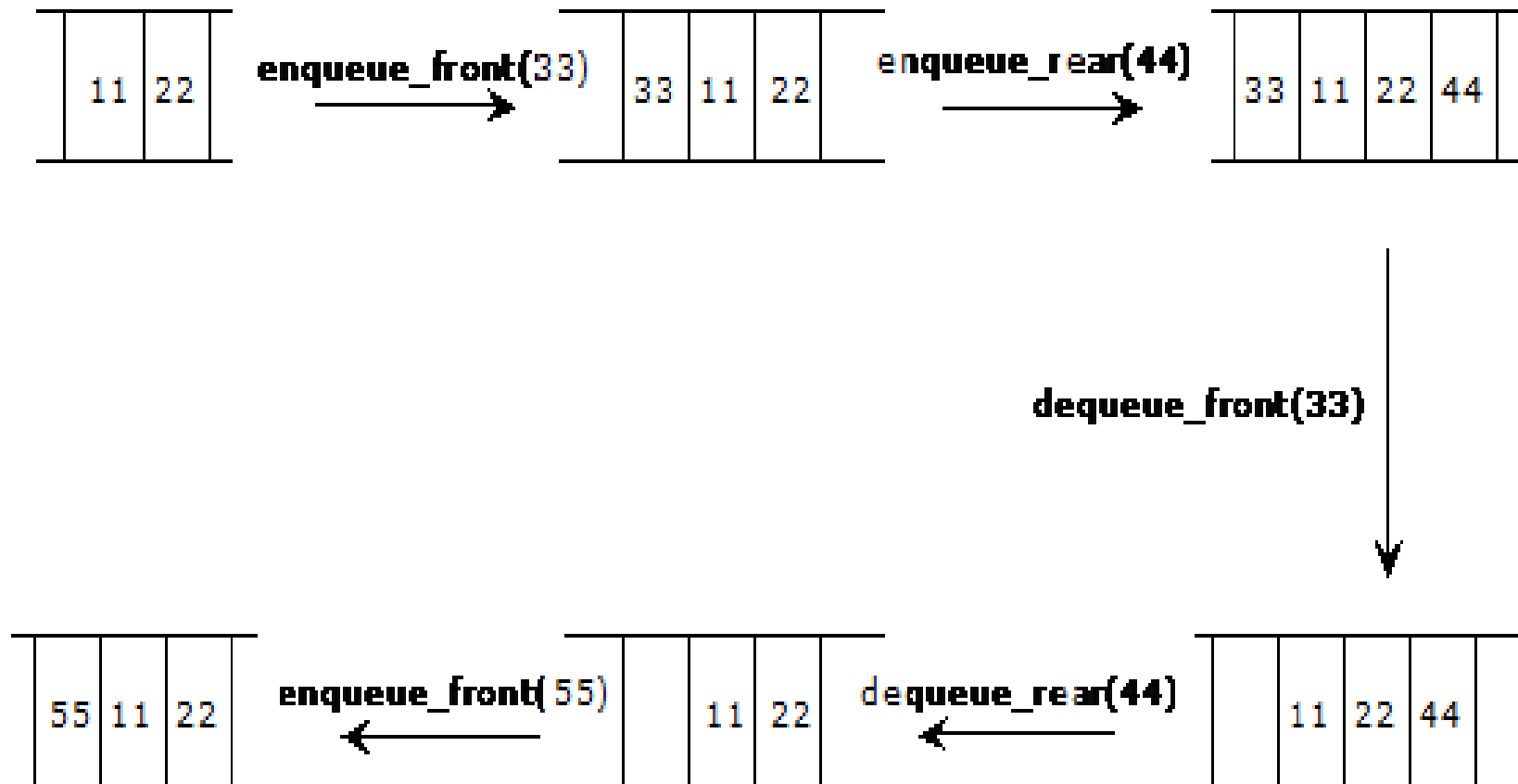

Types of DEQUE

- **There are two variations of deque. They are:**
 - **Input restricted deque (IRD)**
 - **Output restricted deque (ORD)**
- **An Input restricted deque is a deque, which allows insertions at one end but allows deletions at both ends of the list.**
- **An output restricted deque is a deque, which allows deletions at one end but allows insertions at both ends of the list.**

Applications of Deque

- Since Deque supports both stack and queue operations, it can be used as both.
- The Deque data structure supports clockwise and anticlockwise rotations in $O(1)$ time which can be
- useful in certain applications.
- Also, the problems where elements need to be removed and or added both ends can be efficiently
- solved using Deque.

MODULE – III

LINKED LISTS

Running Course learning Outcomes



The course will enable the students to:

CLO 8	Understand dynamic data structures and their real time applications.
CLO 9	Understand the basic insertion and deletion operations associated with linked list.
CLO 10	Organize the data in various linked representation format.

Contents

- **Introduction to Linked list Advantages and Disadvantages of Linked List**
- **Types of Linked List**
- **Single Linked List**
- **Applications of Linked List**
- **Circular Single Linked list**
- **Double Linked List**

Arrays versus Linked Lists

- Both an array and a linked list are representations of a list of items in memory. The only difference is the way in which the items are linked together. The Figure below compares the two representations for a list of five integers.

	scores
scores [1]	66
scores [2]	72
scores [3]	74
scores [4]	85
scores [5]	96

a. Array representation

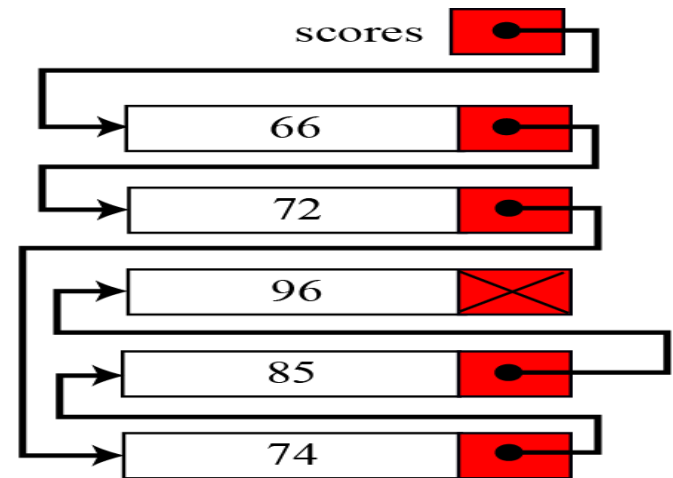

b. Linked list representation

Linked List: A Dynamic Data Structure



- A data structure that can shrink or grow during program execution.
- The size of a dynamic data structure is not necessarily known at compilation time, in most programming languages.
- Efficient insertion and deletion of elements.
- The data in a dynamic data structure can be stored in non-contiguous (arbitrary) locations.
- Linked list is an example of a dynamic data structure.

Advantages of linked list

- Unused locations in array is often a wastage of space
- Linked lists offer an efficient use of memory
 - Create nodes when they are required
 - Delete nodes when they are not required anymore
 - We don't have to know in advance how long the list should be

Applications of linked list

- Linked lists are used to represent and manipulate polynomial. Polynomials are expression containing terms with non zero coefficient and exponents. For example:

$$P(x) = a_0 X^n + a_1 X^{n-1} + \dots + a_{n-1} X + a_n$$

- Represent very large numbers and operations of the large number such as addition, multiplication and division.
- Linked lists are to implement stack, queue, trees and graphs.
- Implement the symbol table in compiler construction.

- There are four types of Linked lists:
 - Single linked list
 - Begins with a pointer to the first node
 - Terminates with a null pointer
 - Only traversed in one direction
 - Circular single linked list
 - Pointer in the last node points back to the first node
 - Doubly linked list
 - Two —start pointersll – first element and last element
 - Each node has a forward pointer and a backward pointer
 - Allows traversals both forwards and backwards
 - Circular double linked list
 - Forward pointer of the last node points to the first node and backward pointer of the first node points to the last node

Singly Linked Lists

- A singly linked list is a concrete data structure consisting of a sequence of nodes
- Each node stores
 - Element
 - link to the next node

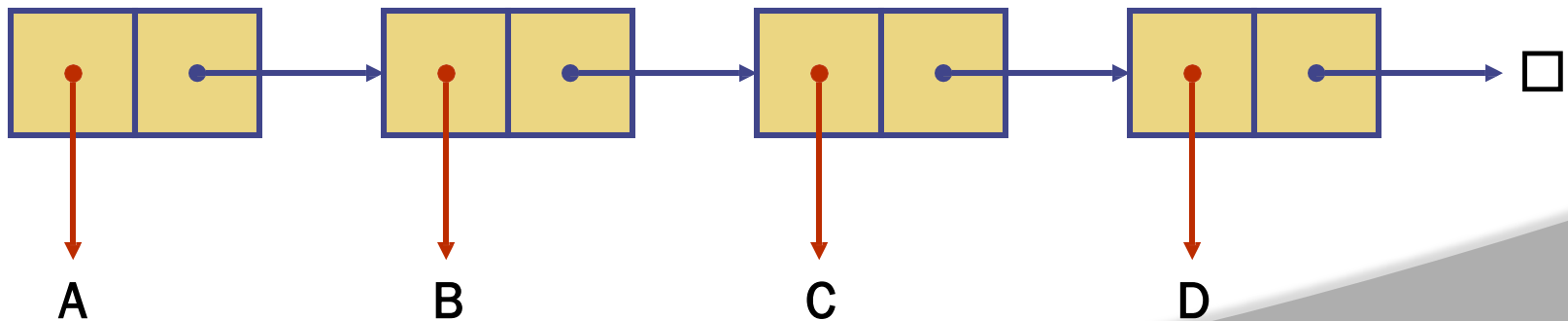
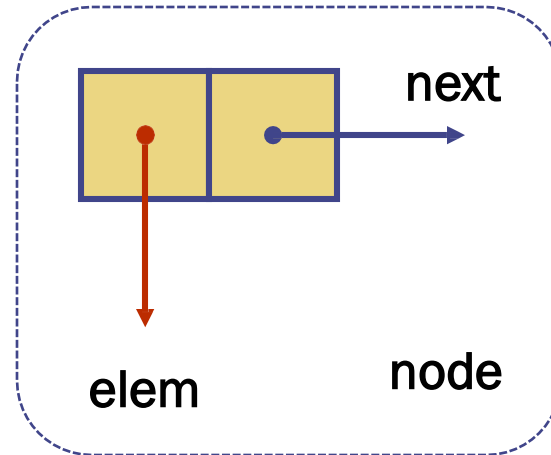

Singly Linked Lists

- A linked list allocates space for each element separately in its own block of memory called a "node".
- Each node contains two fields; a "data" field to store whatever element, and a "next" field which is a pointer used to link to the next node.
- Each node is allocated in the heap using `malloc()`, so the node memory continues to exist until it is explicitly de-allocated using `free()`.
- The front of the list is a pointer to the —startll node.

Single Linked List

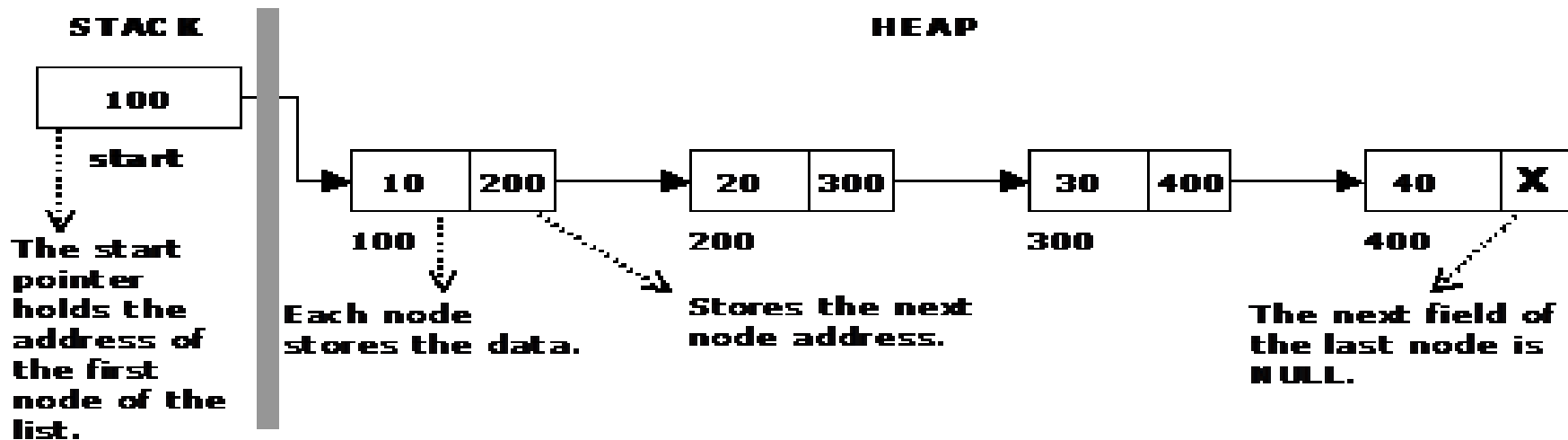

```
struct linklist
{
    int data;
    struct linklist* next;
};
```

```
typedef struct linklist node;
```

```
node *start = NULL;
```

node:



Empty list:



- The basic operations of a single linked list are
 - Creation
 - Insertion
 - Deletion
 - Traversing

Creating a node for Single Linked List:

Sufficient memory has to be allocated for creating a node. The information is stored in the memory, allocated by using the malloc() function. The function getnode(), is used for creating a node, after allocating memory for the structure of type node, the information for the item (i.e., data) has to be read from the user, set next field to NULL and finally returns the address of the node.

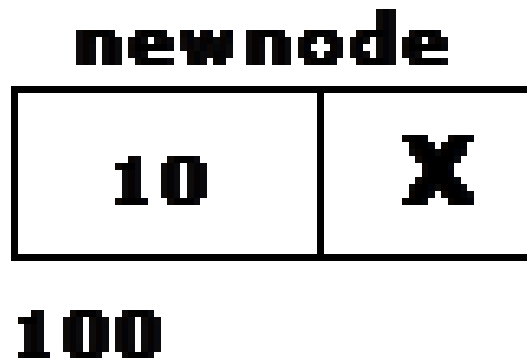

```
class Node:  
    def __init__(self,data,nextNode=None):  
        self.data = data  
        self.nextNode = nextNode  
    def getData(self):  
        return self.data  
    def setData(self,val):  
        self.data = val  
    def getNextNode(self):  
        return self.nextNode  
    def setNextNode(self,val):  
        self.nextNode = val
```

```
class LinkedList:  
    def __init__(self, head = None): self.head = head  
    self.size = 0  
    def getSize(self):  
        return self.size  
    def addNode(self, data):  
        newNode = Node(data, self.head) self.head =  
        newNode self.size+=1  
    def printNode(self):  
        curr = self.head while curr:  
            print(curr.data)  
            curr = curr.getNextNode()
```

Creating a single linked list with N nodes

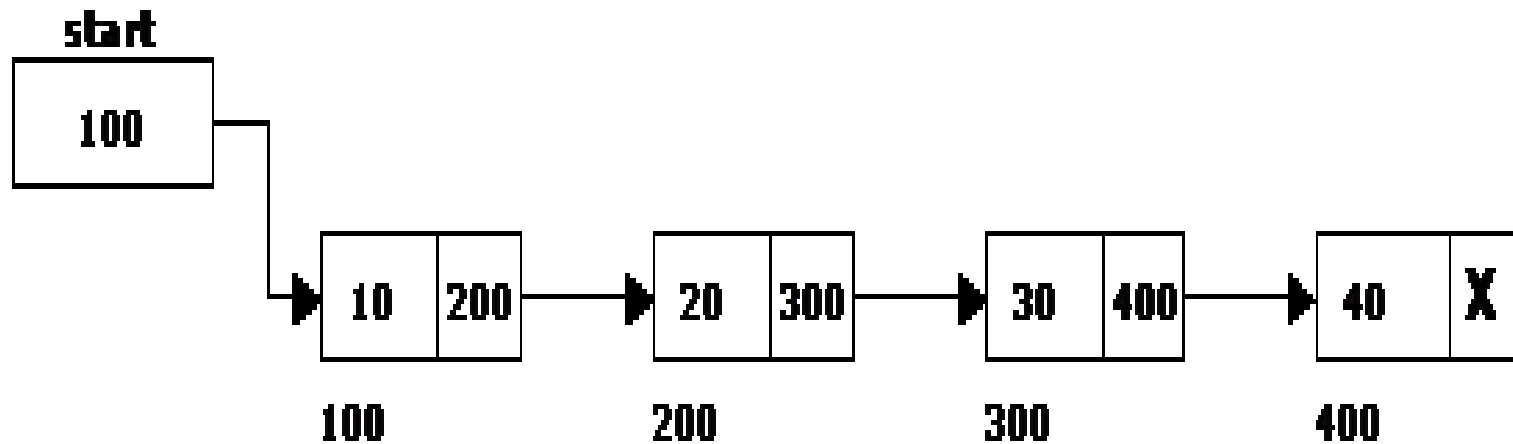

Inserting a node

- Inserting a node into a single linked list can be done at
 - Inserting into an empty list.
 - Insertion at the beginning of the list.
 - Insertion at the end of the list.
 - Insertion in the middle of the list.

Inserting a node at the beginning

```
#Function to insert a new node at the def push(self,  
new_data):  
  
# Allocate the Node & Put in the data  
  
new_node = Node(new_data)  
  
#Make next of new Node as head  
  
new_node.next = self.head  
  
# Move the head to point to new Node self.head =  
new_node
```

Inserting a node at the beginning

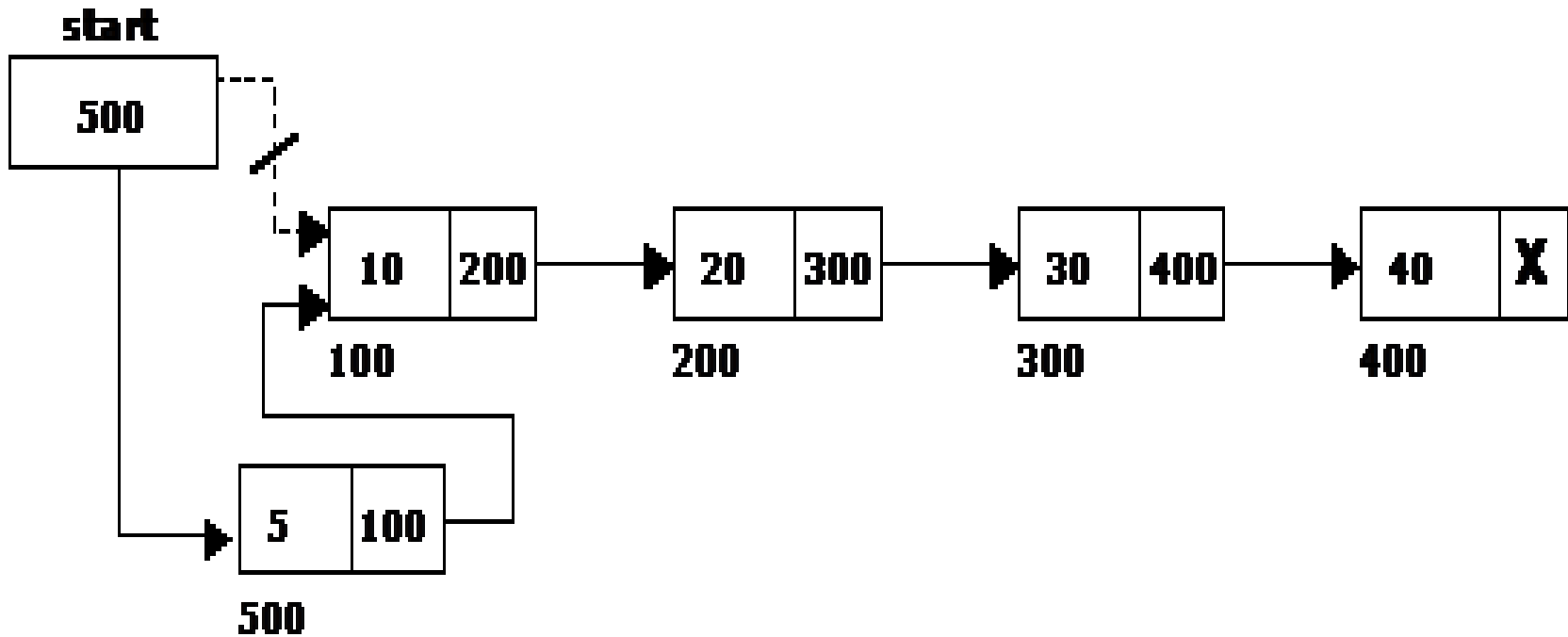

Inserting a node at the end

- The following steps are followed to insert a new node at the end of the list:
This function is defined in Linked List class # Appends a new node at the end. This method is defined inside LinkedList class shown above
def append(self, new_data):
Create a new node, Put in the data, Set next as None
new_node = Node(new_data)

If the Linked List is empty, then make the new node as head
if self.head is None: self.head = new_node return
#Else traverse till the last node last = self.head
while last.next:
last = last.next
Change the next of last node last.next = new_node

Inserting a node at the end

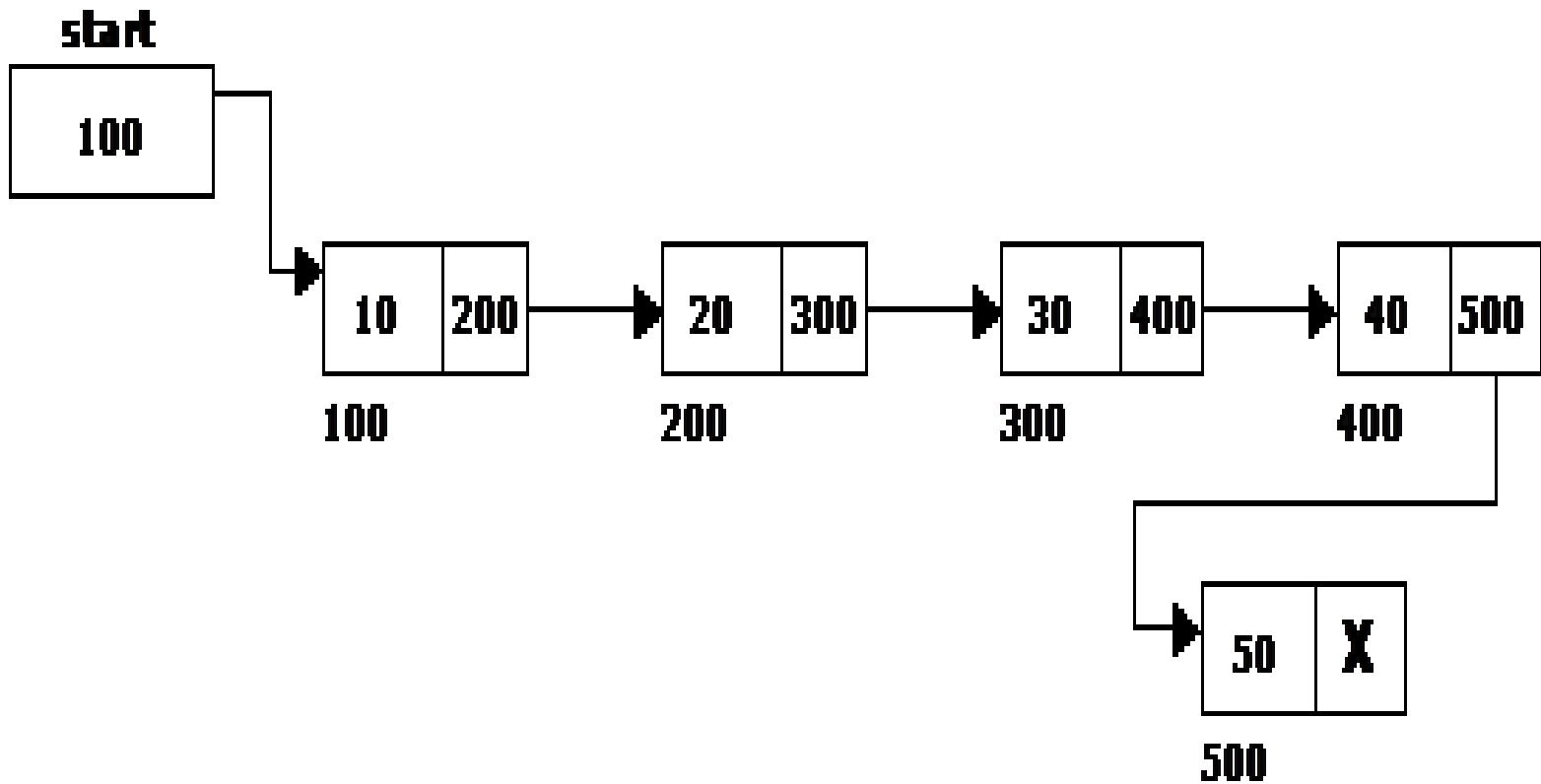

Inserting a node at intermediate position

- The following steps are followed, to insert a new node after the given previous node in the list:

```
def insertAfter(self, prev_node, new_data): #check if the given prev_node
    exists
```

```
if prev_node is None:
```

```
    print(—The given previousnode must in Linked List.))
```

```
    return
```

```
    #Create new node & Put in the data new_node = Node(new_data)
```

```
    # Make next of new Node as next of prev_node new_node.next =
    prev_node.next
```

```
    #Make next of prev_node as new_node prev_node.next = new_node
```

Inserting a node at intermediate position

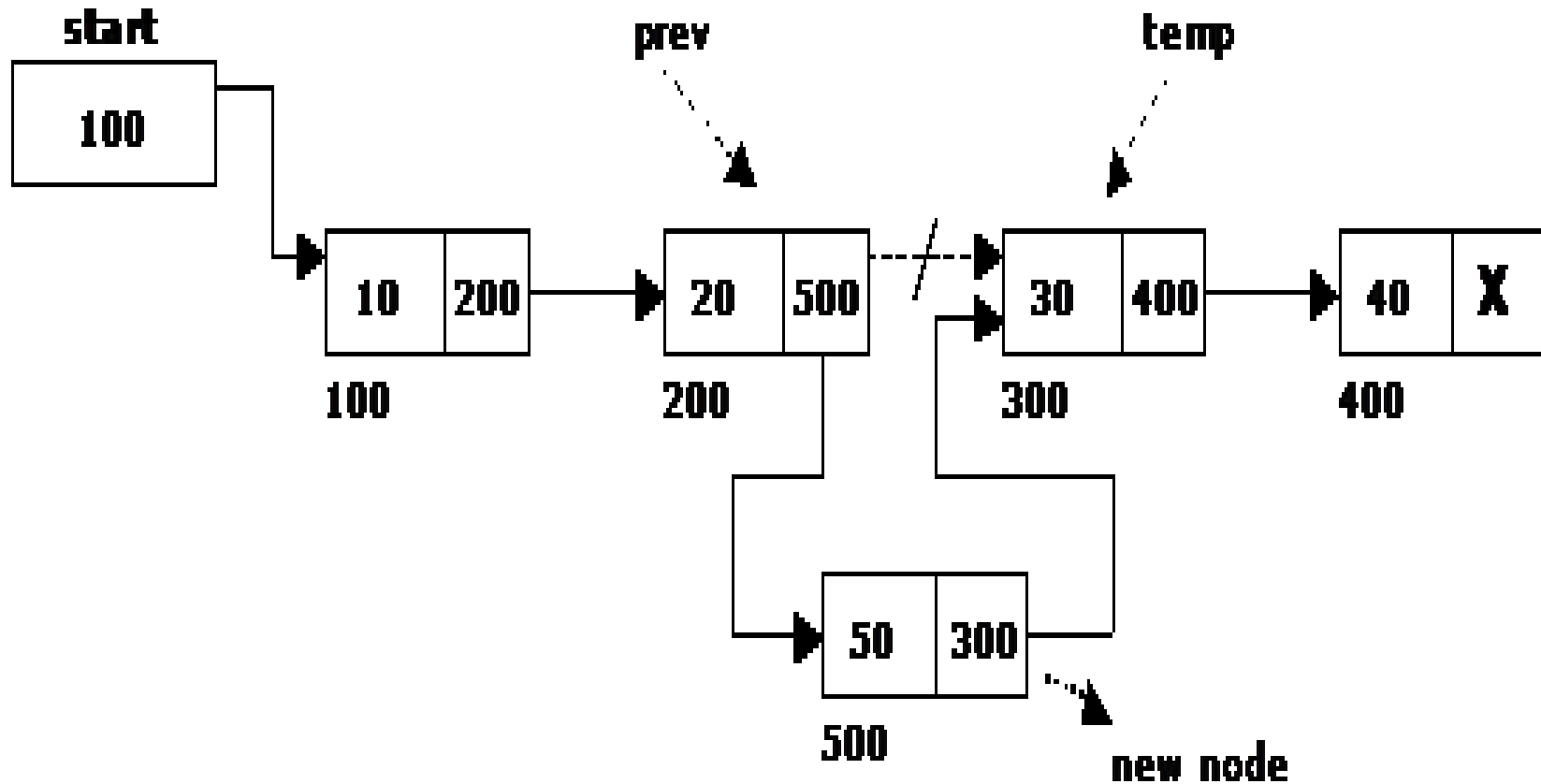

Deletion of a node

- Another primitive operation that can be done in a singly linked list is the deletion of a node. Memory is to be released for the node to be deleted. A node can be deleted from the list from three different places namely.
 - Deleting a node at the beginning.
 - Deleting a node at the end.
 - Deleting a node at intermediate position.

Deleting a node at the beginning

- The following steps are followed, to delete a node at the beginning of the list:

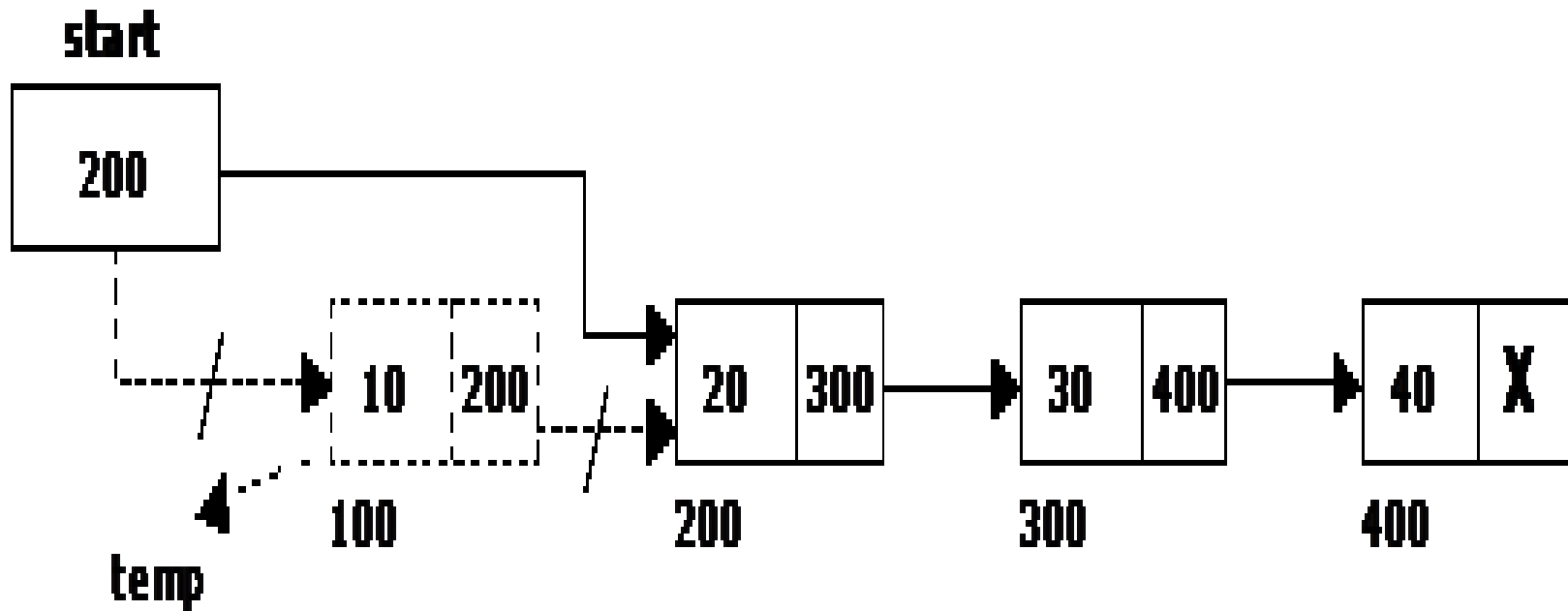

Deleting a node at the end

- The following steps are followed to delete a node at the end of the list:
 - If list is empty then display `_Empty List` message.
 - If the list is not empty, follow the steps given below:

```
temp = prev = start; while(temp -> next != NULL)
{
prev = temp;
temp = temp -> next;
}
prev -> next = NULL; free(temp);
```

Deleting a node at the end

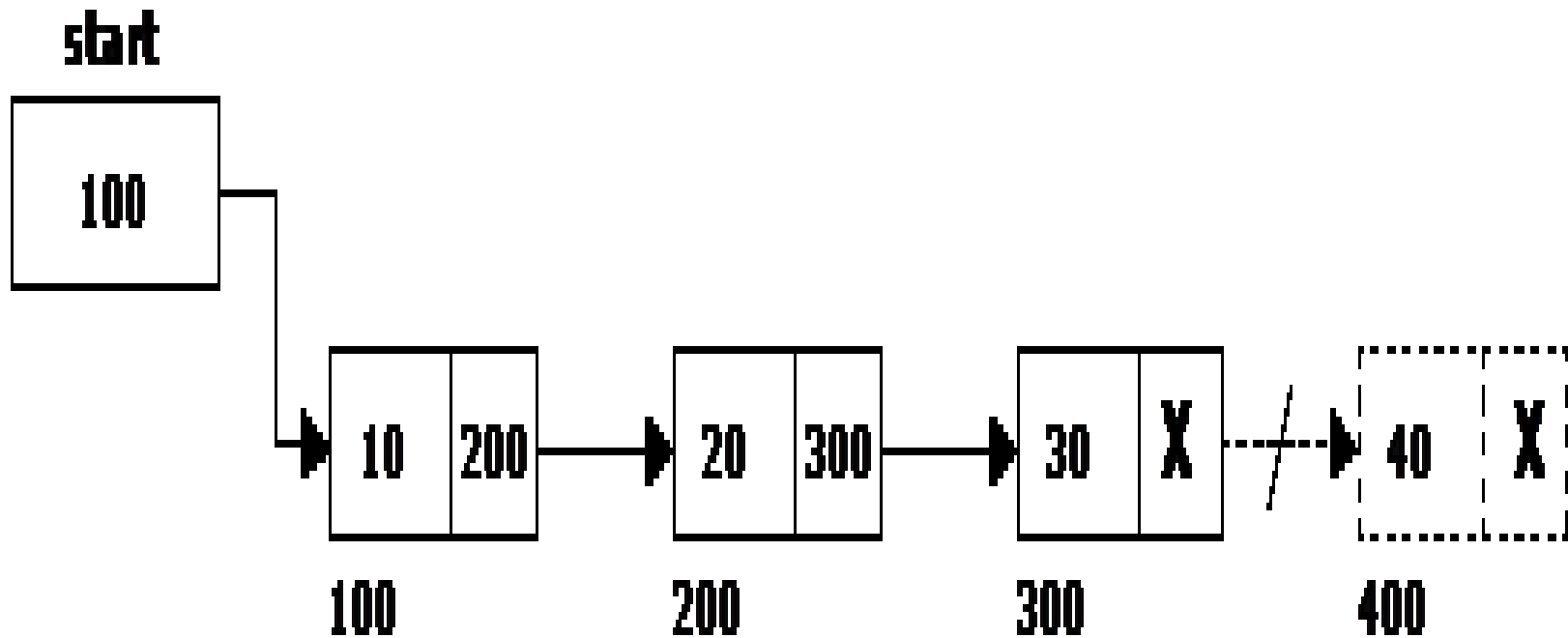

Deleting a node at Intermediate position

- The following steps are followed, to delete a node from an intermediate position in the list:

```
# Given a reference to the head of a list and a position, delete the node
  at a given position def deleteNode(self, position):
```

```
# If linked list is empty if self.head == None:
```

```
return
```

```
# Store head node temp = self.head
```

```
# If head needs to be removed if position == 0:
```

```
self.head = temp.next temp = None
```

```
return
```

```
# Find previous node of the node to be deleted
```

```
for i in range(position -1 ): temp = temp.next
```

```
if temp is None: break
```

```
# If position is more than number of nodes
  if temp is None:
    return
  if temp.next is None: return
  # Node temp.next is the node to be deleted store pointer to the next of
  node to be deleted
  next = temp.next.next
  # Unlink the node from linked list temp.next = None temp.next=next
# Find previous node of the node to be deleted for i in range(position -1 ):
temp = temp.next if temp is None:
break

# If position is more than number of nodes if temp is None:
return
if temp.next is None: return
```

Deleting a node at Intermediate position

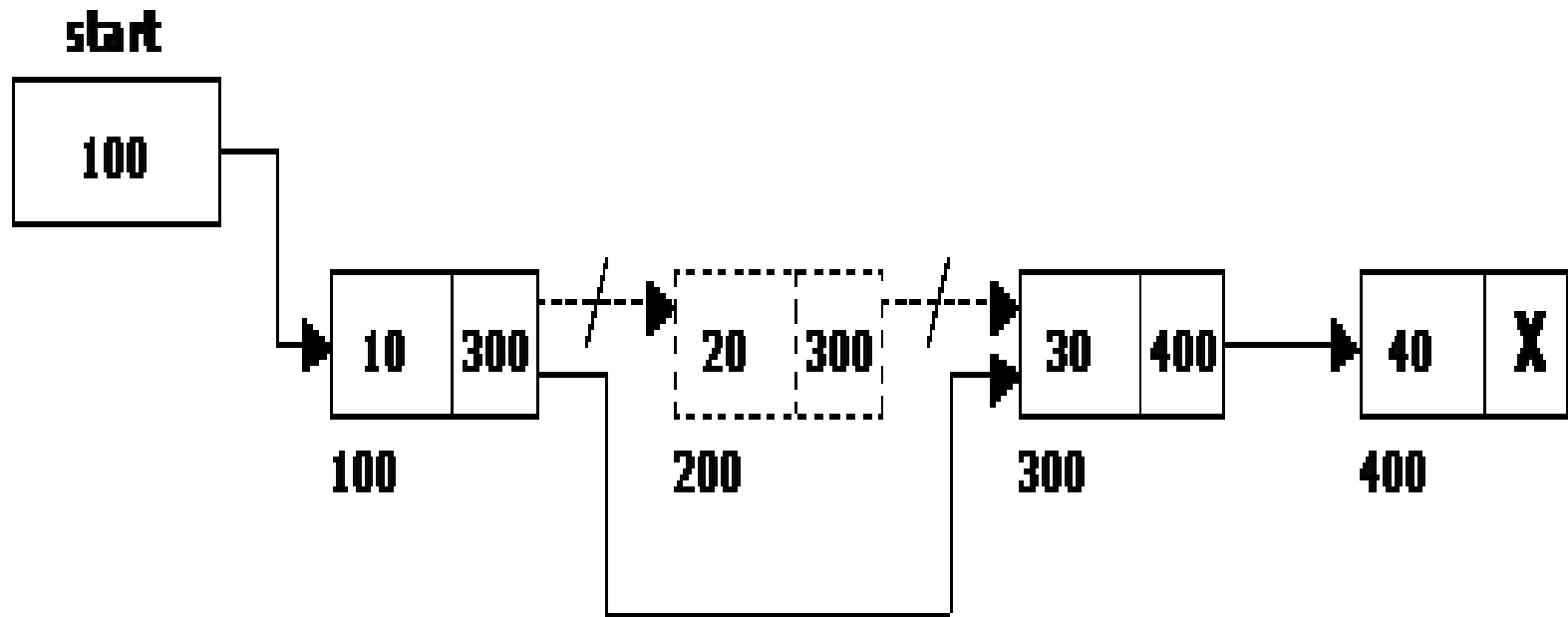

Traversal and displaying a list

- To display the information, you have to traverse (move) a linked list, node by node from the first node, until the end of the list is reached. Traversing a list involves the following steps:
 - Assign the address of start pointer to a temp pointer.
 - Display the information from the data field of each node.

Double Linked List

- A double linked list is a two-way list in which all nodes will have two links. This helps in accessing both successor node and predecessor node from the given node position. It provides bi-directional traversing. Each node contains three fields:
 - Left link.
 - Data.
 - Right link.
- The left link points to the predecessor node and the right link points to the successor node. The data field stores the required data.

A Double Linked List

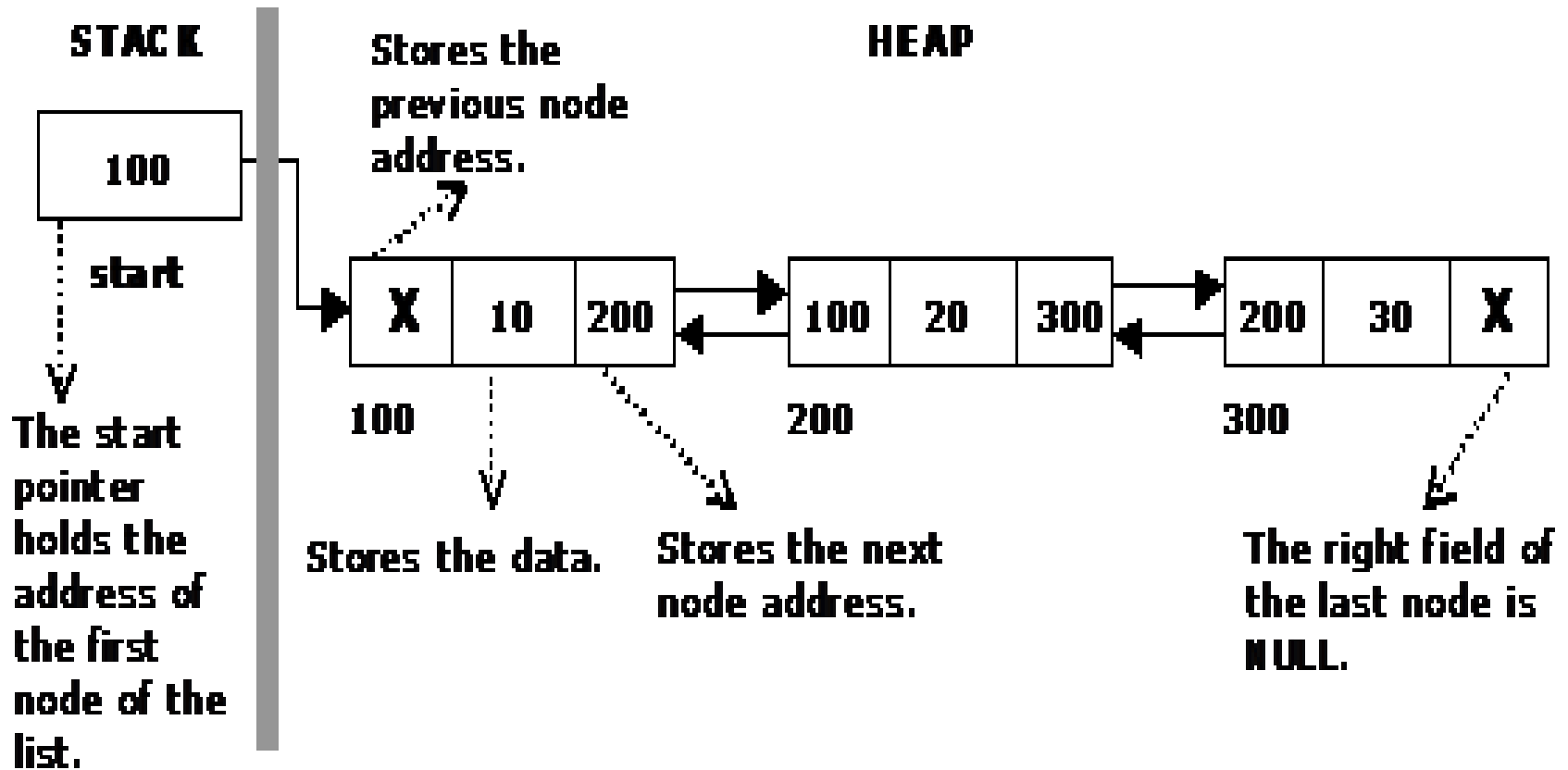

Basic operations in a double linked list

- Creation
- Insertion
- Deletion
- Traversing
- The beginning of the double linked list is stored in a "**start**" pointer which points to the first node. The first node's left link and last node's right link is set to NULL.

Structure of a Double Linked List

```

struct dlinklist
{
    struct dlinklist *left;
    int data;
    struct dlinklist *right;
};

```

```

typedef struct dlinklist node;
node *start = NULL;

```

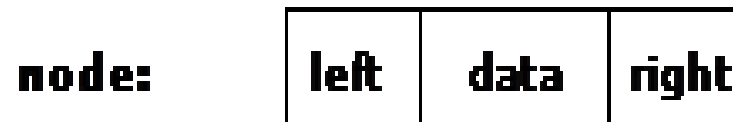

Creating a Double Linked List with N number of nodes

- The following steps are to be followed to create

n' number of nodes:

```
class Node(object):
```

```
def _____init_____(self, data, prev, next): self.data = data
```

```
self.prev = prev
```

```
self.next = next
```

```
class DoubleList(object): head = None
```

```
tail = None
```

Creating a Double Linked List with N number of nodes

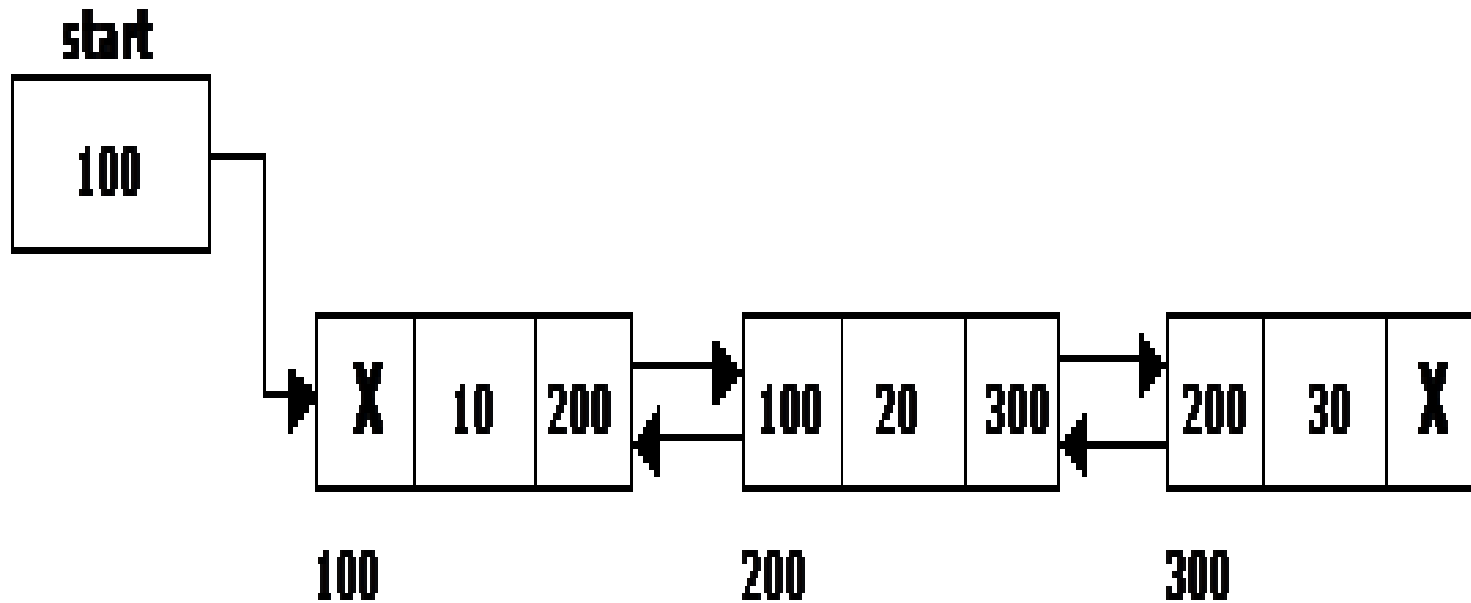

Inserting a node at the beginning

- The following steps are to be followed to insert a new node at the beginning of the list:
- Get the new node using `getnode()`. `newnode=getnode();`
- If the list is empty then `start = newnode`.
- If the list is not empty, follow the steps given below:
`newnode -> right = start;` `start -> left = newnode;` `start =`

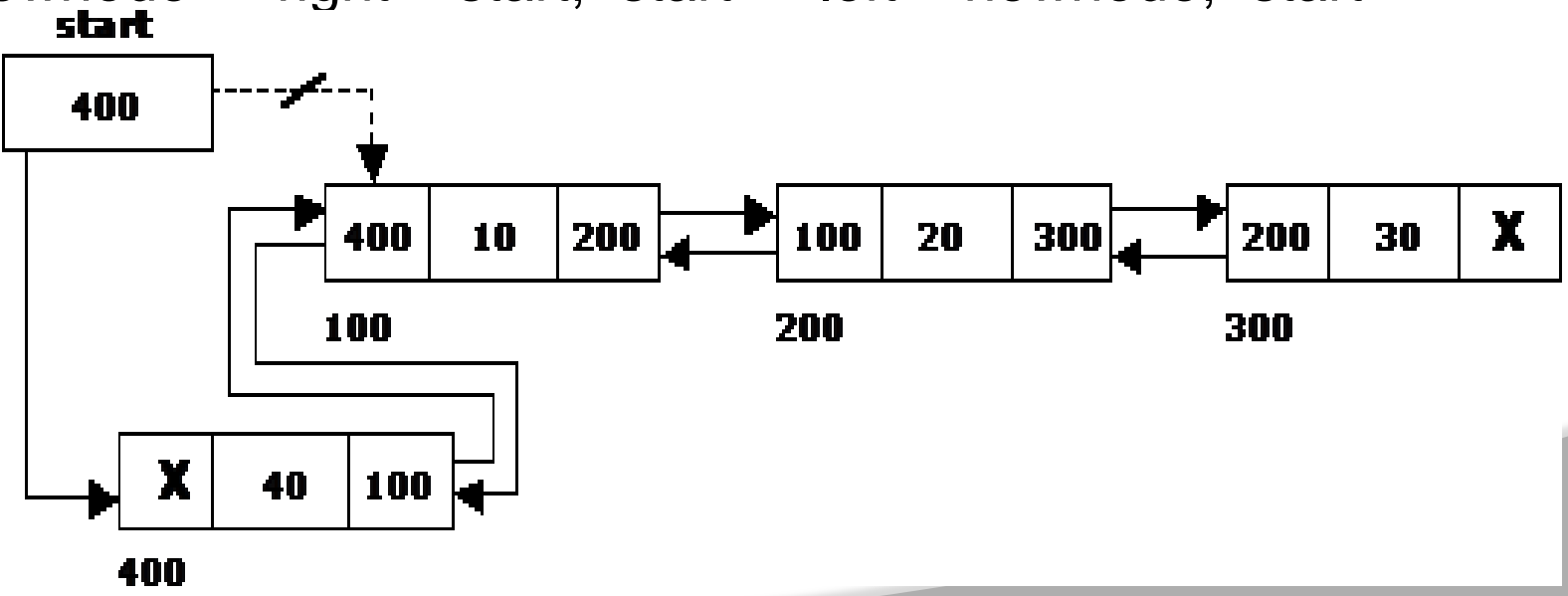

Inserting a node at the beginning

- The following steps are followed to insert a new node at the end of the list:
- Get the new node using `getnode()`
`newnode=getnode();`
- If the list is empty then `start = newnode.`
- If the list is not empty follow the steps given below:
`temp = start;`
`while(temp -> right != NULL) temp = temp -> right;`
`temp -> right = newnode; newnode -> left = temp;`

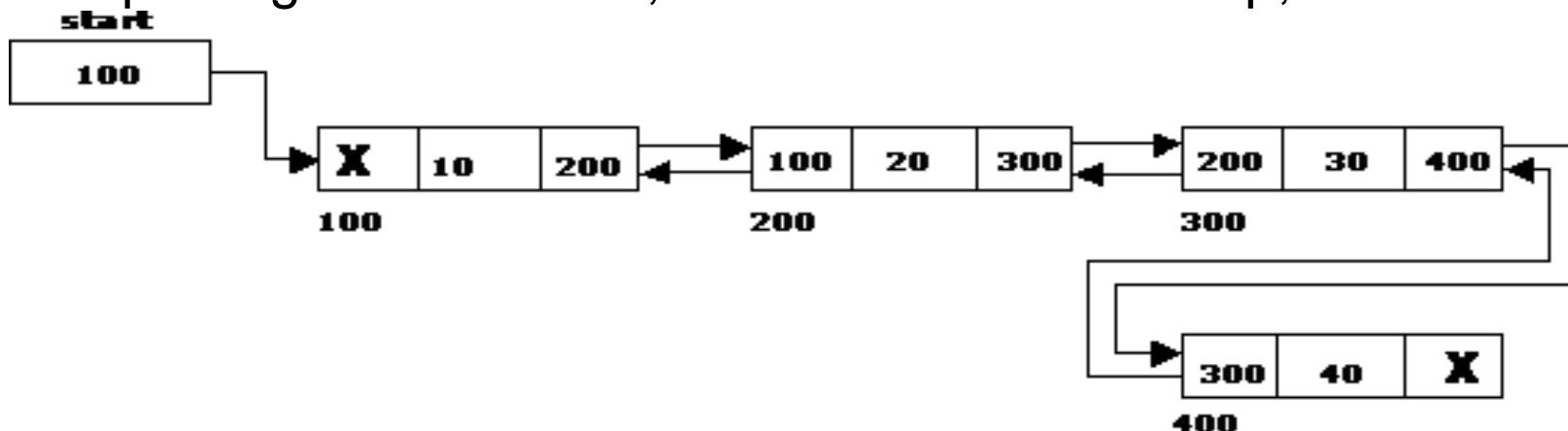

Inserting a node at an intermediate position

- The following steps are followed, to insert a new node in an intermediate position in the list:

Get the new node using `getnode()`. `newnode=getnode();`

- Ensure that the specified position is in between first node and last node. If not, specified position is invalid. This is done by `countnode()` function.
- Store the starting address (which is in start pointer) in temp and prev pointers. Then traverse the temp pointer upto the specified position followed by prev pointer.

After reaching the specified position, follow the steps given

below: `newnode -> left = temp;`

`newnode -> right = temp -> right; temp -> right -> left = newnode;`

`temp -> right = newnode;`

Inserting a node at an intermediate position

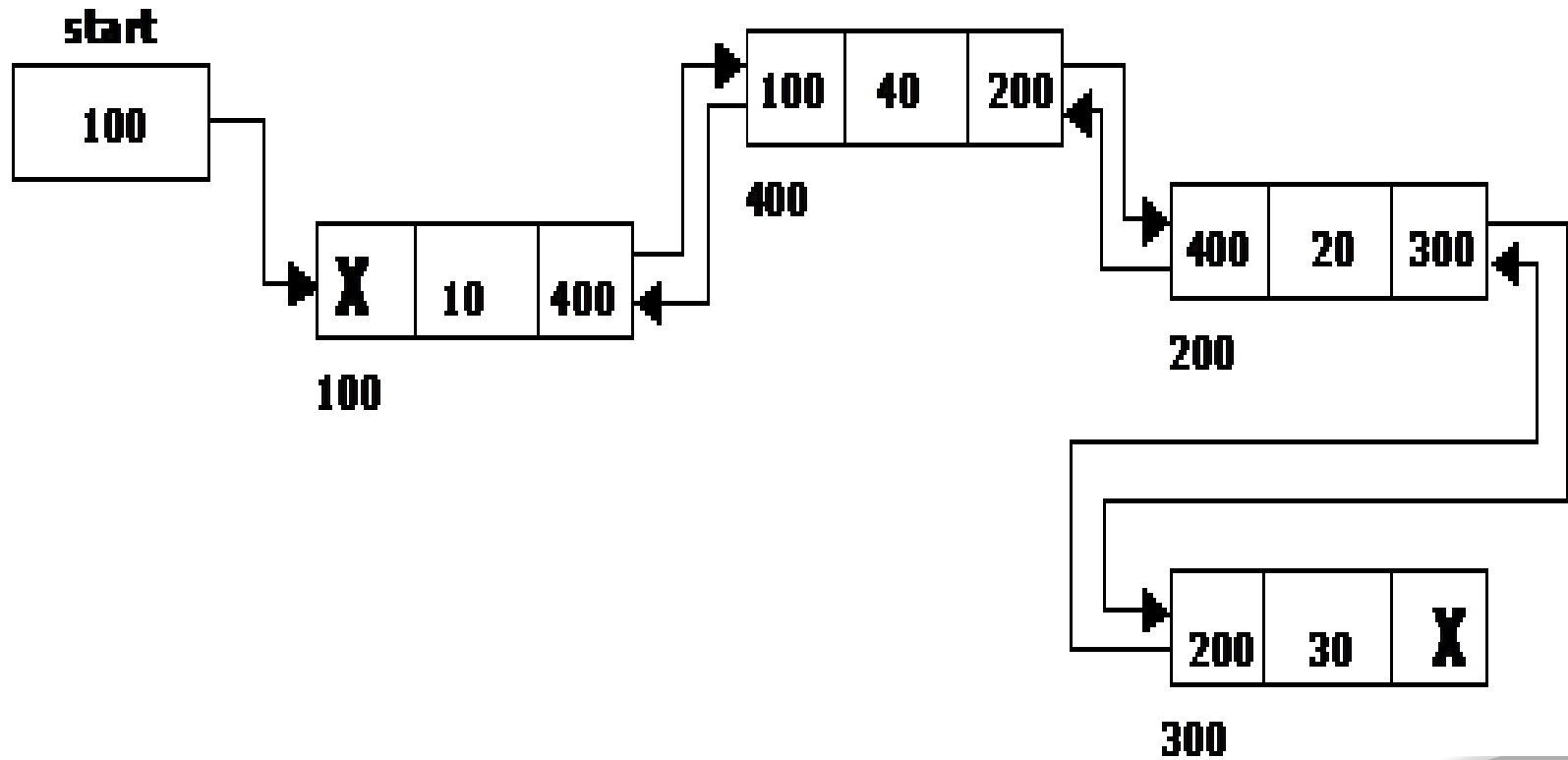

Deleting a node at the end

- The following steps are followed to delete a node at the end of the list:
 - If list is empty then display `_Empty List'` message
 - If the list is not empty, follow the steps given below:

```
temp = start;
while(temp -> right != NULL)
{
temp = temp -> right;
}
temp -> left -> right = NULL; free(temp);
```

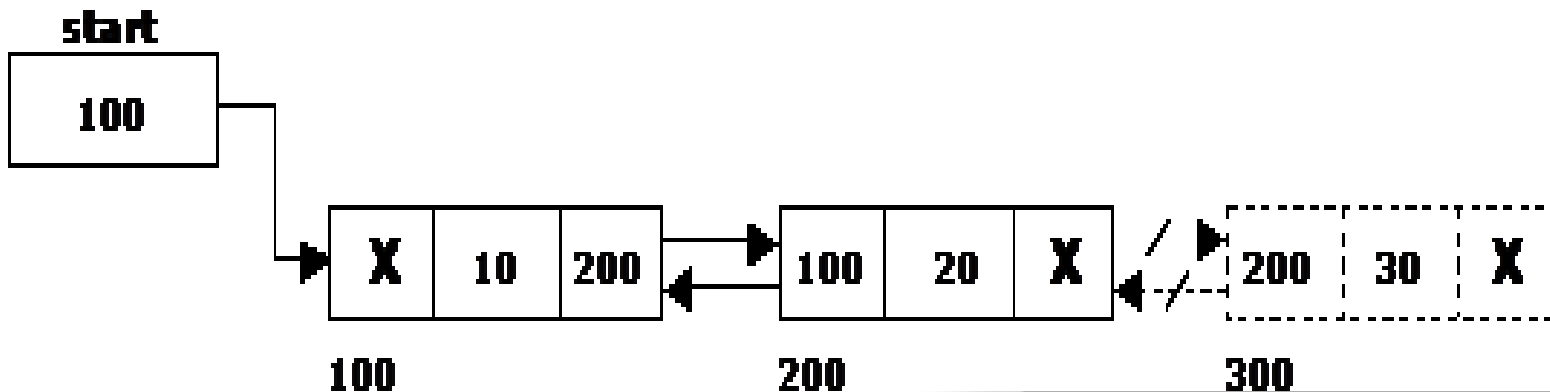

Deleting a node at Intermediate position

intermediate position in the list.

- If list is empty then display 'Empty List' message.
- If the list is not empty, follow the steps given below:
 - Get the position of the node to delete.
 - Ensure that the specified position is in between first node and last node. If not, specified position is invalid.
- Then perform the following steps:

```
if(pos > 1 && pos < nodectr)
```

```
{
```

```
temp = start; i = 1;
```

```
while(i < pos)
```

```
{
```

```
temp = temp -> right; i++;
```

```
}
```

```
temp -> right -> left = temp -> left; temp -> left -> right = temp  
-> right; free(temp);
```

```
printf("\n node deleted..");}
```

Deleting a node at Intermediate position

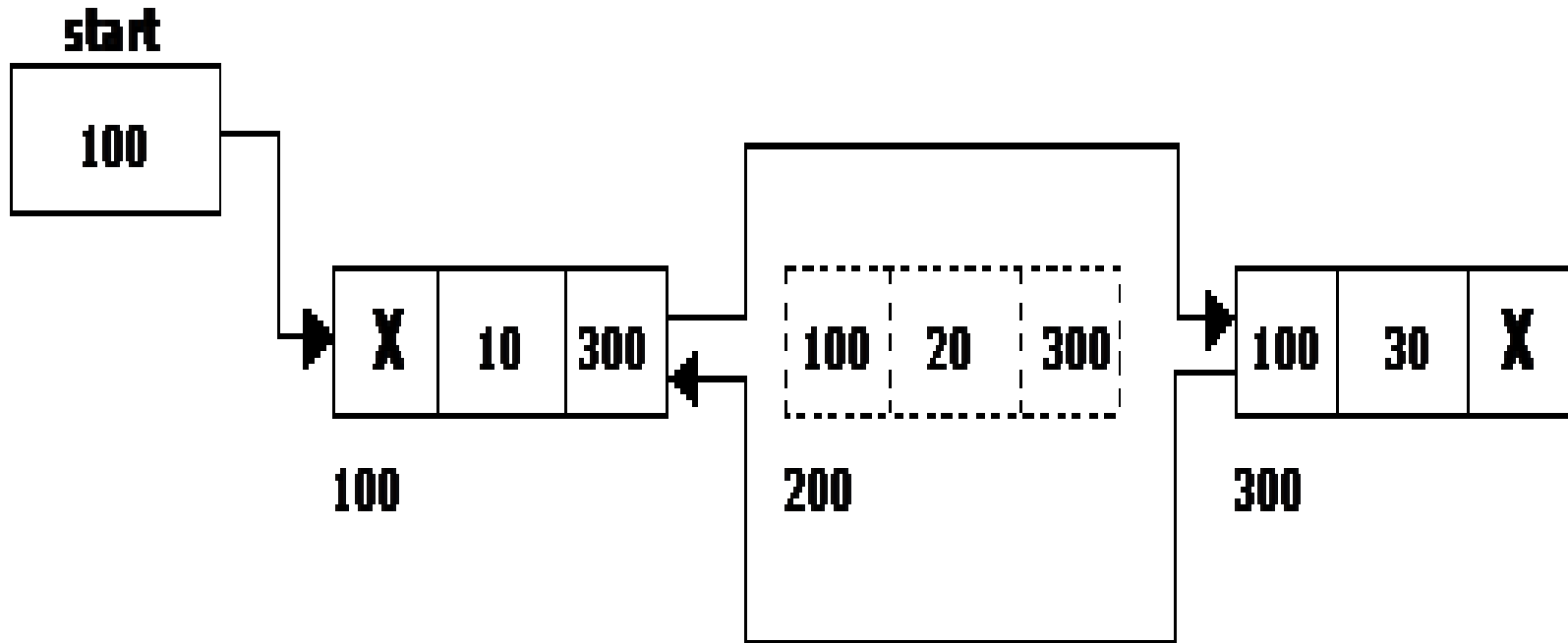

Traversal and displaying a list (Left to Right)

- The following steps are followed, to traverse a list from left to right:
- If list is empty then display Empty List message
 If the list is not empty, follow the steps given below:

```
temp = start;
while(temp != NULL)
{
print    temp -> data; temp = temp -> right;
}
```

Traversal and displaying a list (Right to Left)



- The following steps are followed, to traverse a list from right to left:
- If list is empty then display `_Empty List` message.
- If the list is not empty, follow the steps given below:

```
temp = start;
```

```
while(temp -> right != NULL) temp = temp -> right;
```

```
while(temp != NULL)
```

```
{
```

```
print temp -> data; temp = temp -> left;
```

```
}
```

Advantages and Disadvantages of Double Linked List



- The **major disadvantage** of doubly linked lists (over singly linked lists) is that they require more space (every node has two pointer fields instead of one). Also, the code to manipulate doubly linked lists needs to maintain the *prev* fields as well as the *next* fields; the more fields that have to be maintained, the more chance there is for errors.
- The **major advantage** of doubly linked lists is that they make some operations (like the removal of a given node, or a right-to-left traversal of the list) more efficient.

Circular Single Linked List

- It is just a single linked list in which the link field of the last node points back to the address of the first node.
- A circular linked list has no beginning and no end. It is necessary to establish a special pointer called *start* pointer always pointing to the first node of the list.
- Circular linked lists are frequently used instead of ordinary linked list because many operations are much easier to implement. In circular linked list no null pointers are used, hence all pointers contain valid address.

Circular Single Linked List and its basic operations

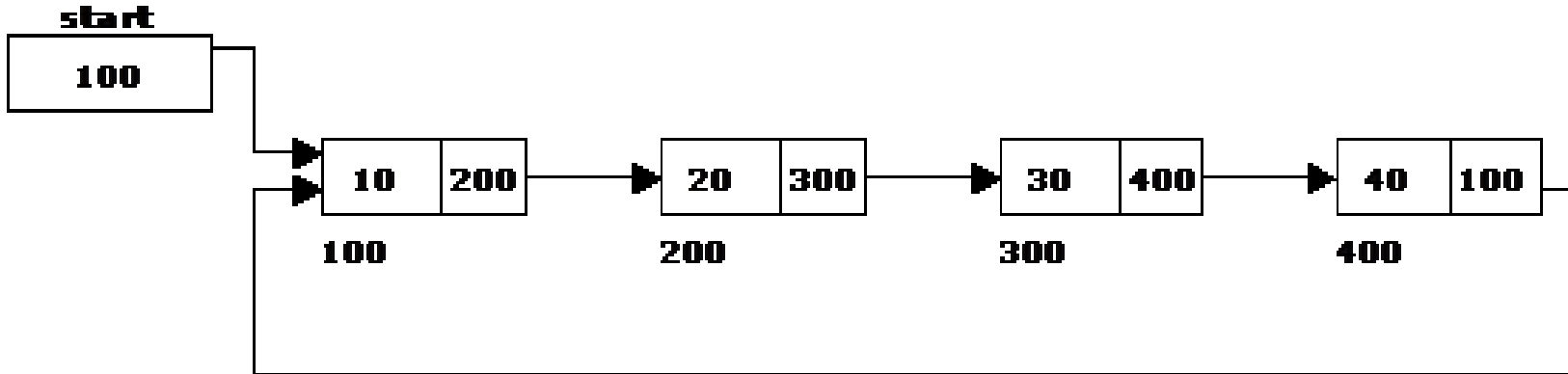

The basic operations in a circular single linked list are:

- Creation
- Insertion
- Deletion
- Traversing

Creating a circular single Linked List with N number of nodes

- The following steps are to be followed to create n' number of nodes:
- Get the new node using `getnode()`.
 `newnode = getnode();`
 If the list is empty, assign new node as `start`. `start = newnode;`
- If the list is not empty, follow the steps given below:
 `temp = start;`
 `while(temp -> next != NULL) temp = temp -> next;`
 `temp -> next = newnode;`
 Repeat the above steps n' times.
 `newnode -> next = start;`

Inserting node at the beginning

- The following steps are to be followed to insert a new node at the beginning of the circular list:
- Get the new node using `getnode()`.

```
newnode = getnode();
```

If the list is empty, assign new node as `start`.

```
start = newnode;
```

```
newnode -> next = start;
```

If the list is not empty, follow the steps given below:

```
last = start;
```

```
while(last -> next != start) last = last -> next;
```

```
newnode -> next = start; start = newnode;
```

```
last -> next = start;
```

Inserting a node at the beginning

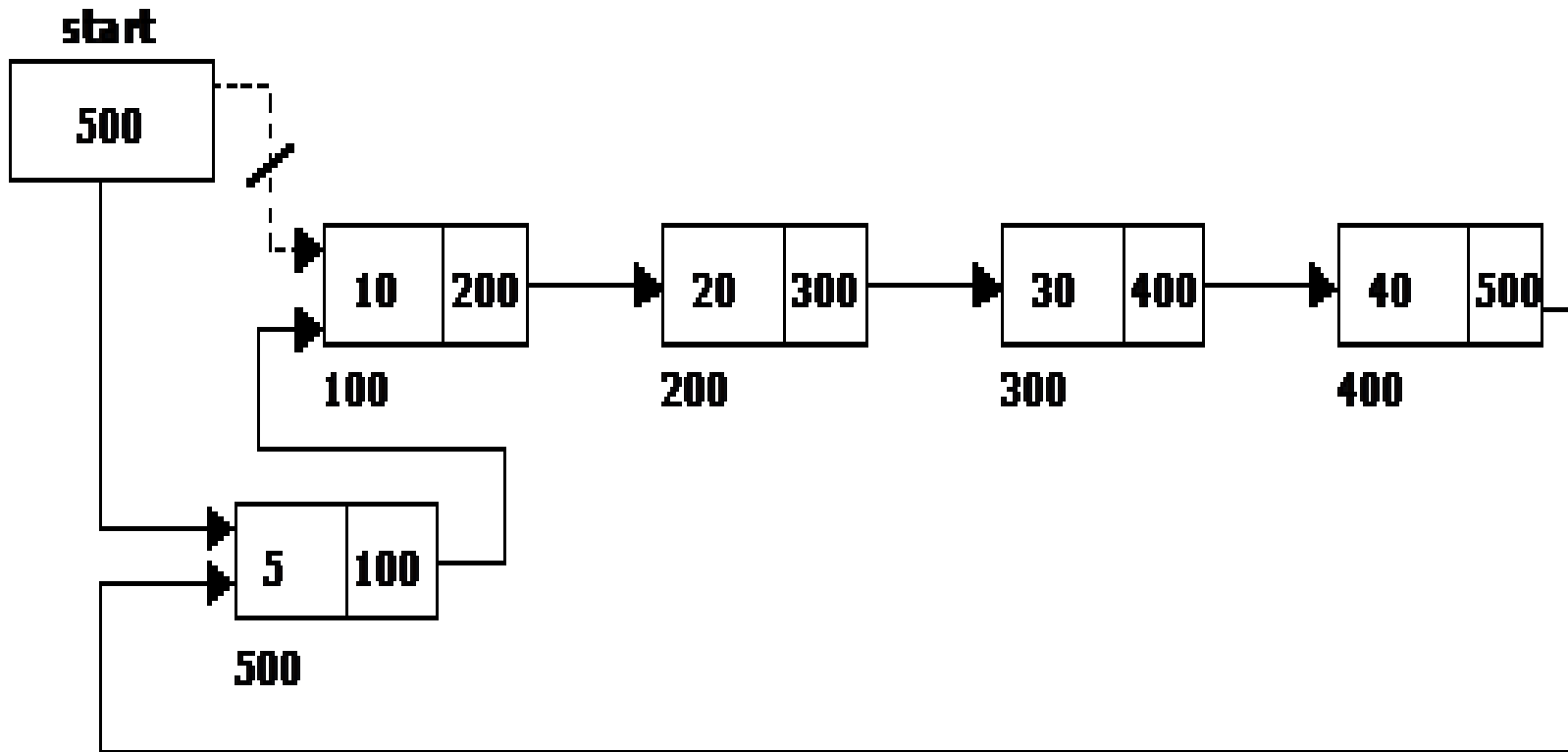

Inserting a node at the end

- The following steps are followed to insert a new node at the end of the list:

Get the new node using `getnode()`.

```
newnode = getnode();
```

If the list is empty, assign new node as `start`.

```
start = newnode;
```

```
newnode -> next = start;
```

If the list is not empty follow the steps given below:

```
temp = start;
```

```
while(temp -> next != start) temp = temp -> next;
```

```
temp -> next = newnode; newnode -> next = start;
```

Inserting a node at the end

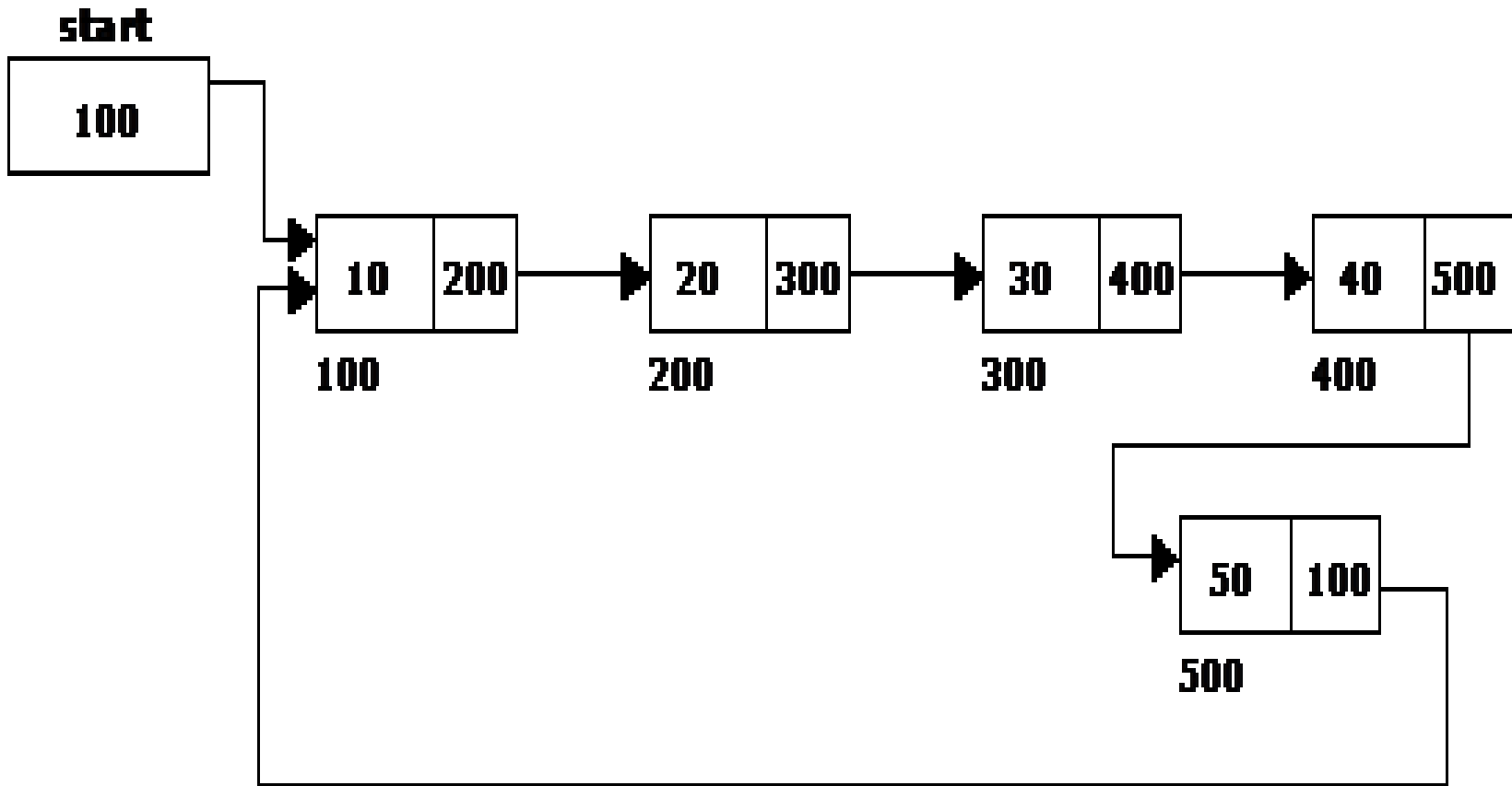

Deleting a node at the beginning

- The following steps are followed, to delete a node at the beginning of the list:
- If the list is empty, display a message 'Empty List'.
- If the list is not empty, follow the steps given below: **last = temp = start;**
while(last -> next != start) last = last -> next;
start = start -> next; last -> next = start;
- After deleting the node, if the list is empty then **start = NULL**.

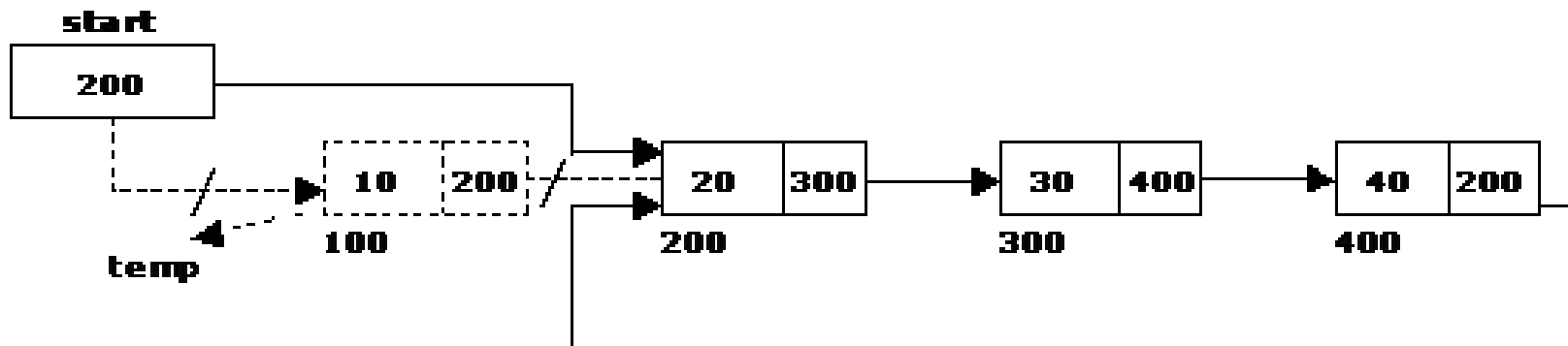

Deleting a node at the end

- The following steps are followed to delete a node at the end of the list:
- If the list is empty, display a message `_Empty List'`.
- If the list is not empty, follow the steps given below: `temp = start;`

```

prev = start;
while(temp -> next != start)
{
prev = temp;
temp = temp -> next;
}
prev -> next = start;

```

- After deleting the node, if the list is empty then `start = NULL`.

Deleting a node at the end

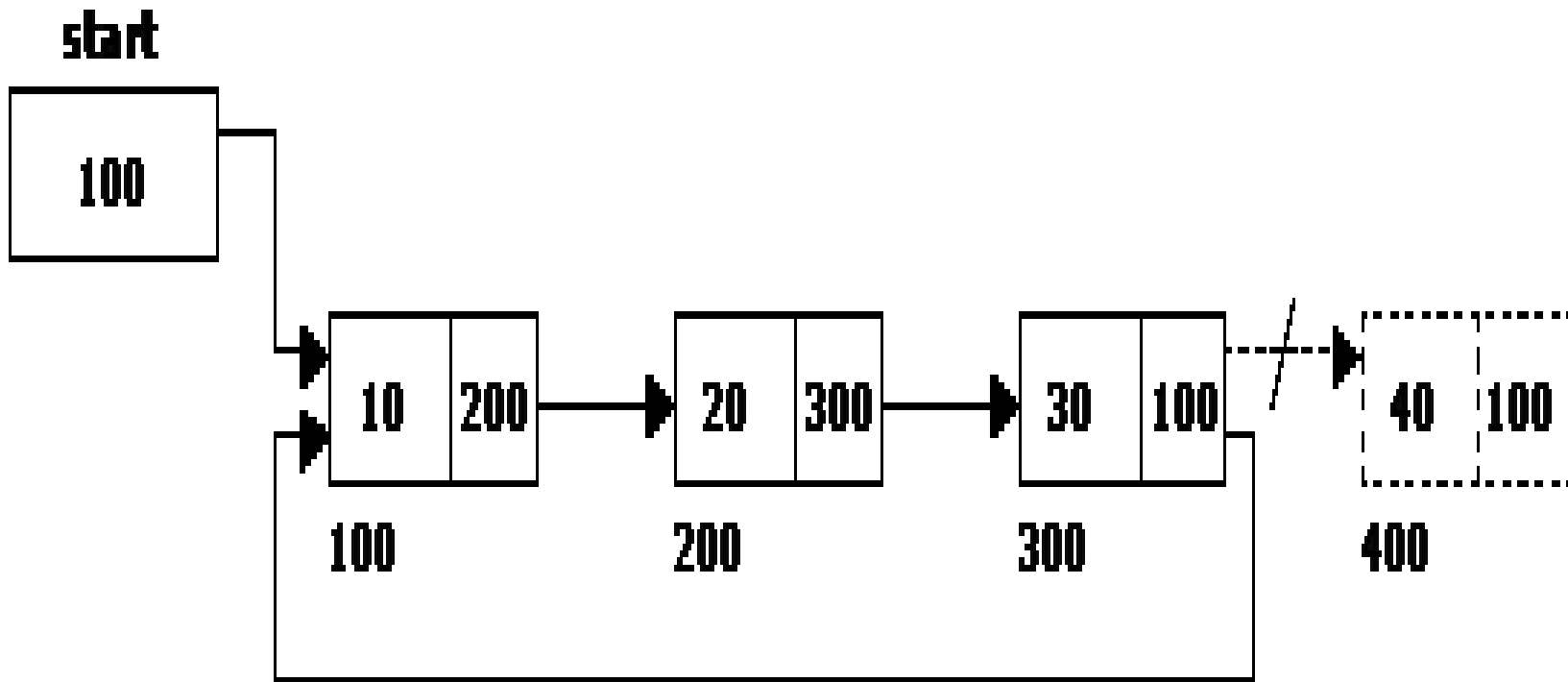

Traversing a circular single linked list from left to right



- The following steps are followed, to traverse a list from left to right:
- If list is empty then display `_Empty List` message.
- If the list is not empty, follow the steps given below:

```
temp = start;
```

```
do
```

```
{
```

```
printf("%d ", temp -> data); temp = temp -> next;
```

```
} while(temp != start);
```

Advantages of Circular Lists

- **The major advantage of circular lists (over non-circular lists) is that they eliminate some extra-case code for some operations (like deleting last node).**
- **Also, some applications lead naturally to circular list representations.**
- **For example, a computer network might best be modeled using a circular list.**

Applications of Linked Lists: Representing Polynomials



A polynomial is of the form:

$$\sum_{i=0}^n c_i x^i$$

Where, c_i is the coefficient of the i^{th} term and n is the degree of the polynomial

Some examples are: $5x^2 + 3x + 1$, $5x^4 - 8x^3 + 2x^2 + 4x^1 + 9x^0$

The computer implementation requires implementing polynomials as a list of pairs of coefficient and exponent. Each of these pairs will constitute a structure, so a polynomial will be represented as a list of structures. A linked list structure that represents polynomials

$5x^4 - 8x^3 + 2x^2 + 4x^1 + 9x^0$ illustrated.

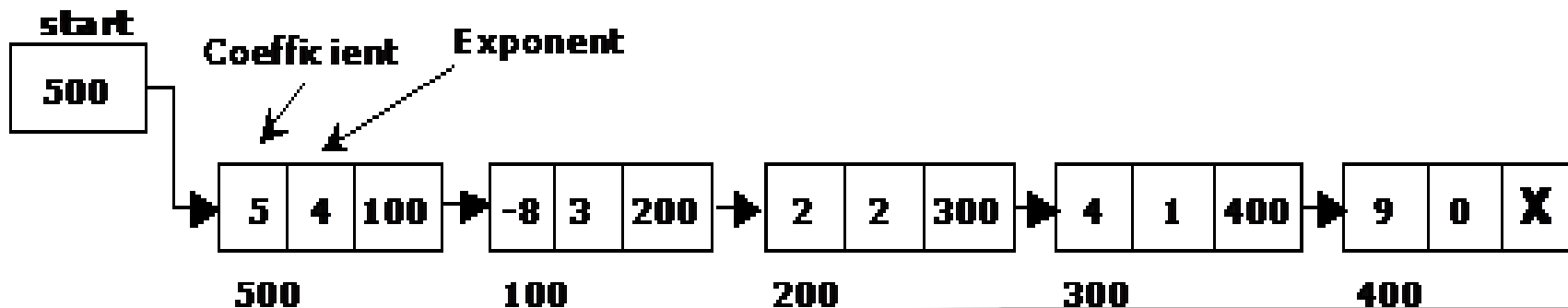

Addition of Polynomials

- To add two polynomials, if we find terms with the same exponent in the two polynomials, then we add the coefficients; otherwise, we copy the term of larger exponent into the sum and go on. When we reach at the end of one of the polynomial, then remaining part of the other is copied into the sum.
- To add two polynomials follow the following steps:
 - Read two polynomials.
 - Add them.
 - Display the resultant polynomial.

MODULE – IV

NON LINEAR DATA STRUCTURES

CONTENTS



- **Basic Tree Concepts, Binary Trees**
- **Representation of Binary Trees**
- **Operations on a Binary Tree**
- **Binary Tree Traversals**
- **Threaded Binary Trees**
- **Basic Graph Concepts**
- **Graph Traversal Techniques: DFS and BFS**

Tree – a Hierarchical Data Structure



- **Trees are non linear data structure that can be represented in a hierarchical manner.**
 - **A tree contains a finite non-empty set of elements.**
 - **Any two nodes in the tree are connected with a relationship of parent-child.**
 - **Every individual elements in a tree can have any number of sub trees.**

An Example of a Tree

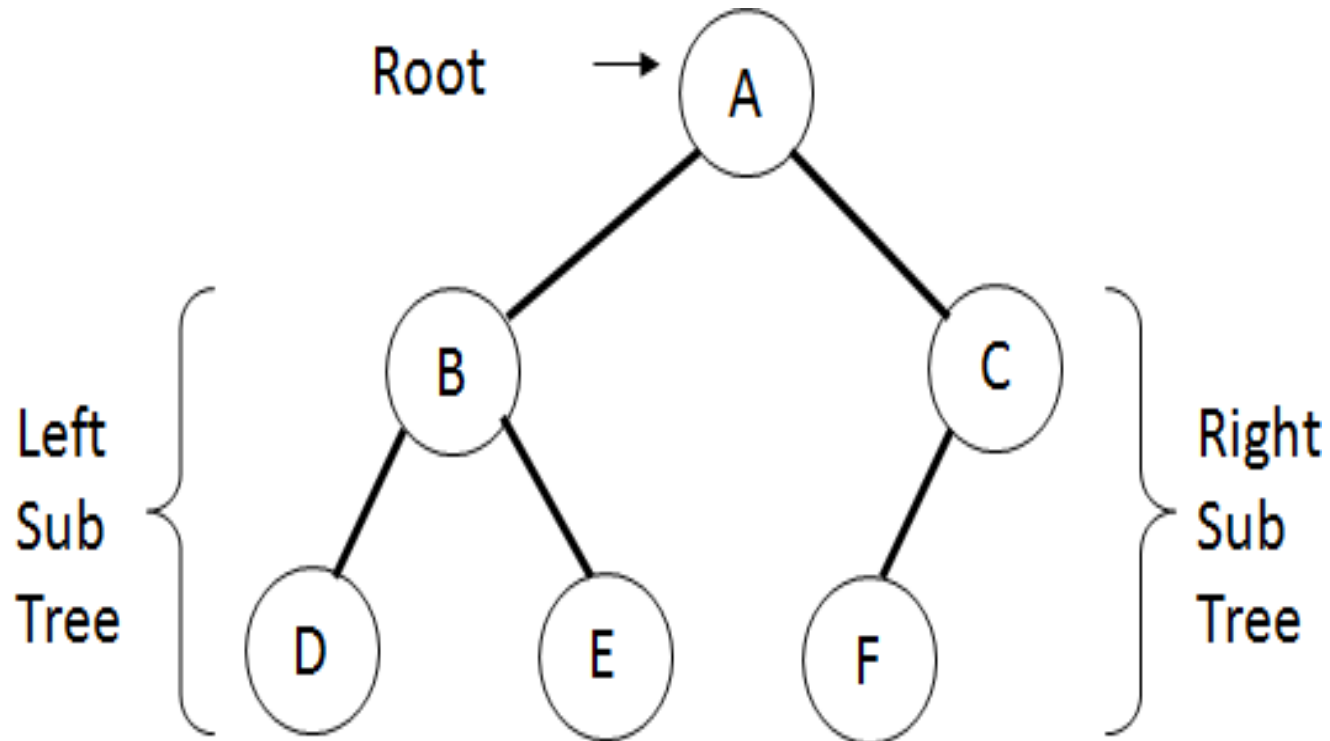

Tree – Basic Terminology

- Root : The basic node of all nodes in the tree. All operations on the tree are performed with passing root node to the functions.
- Child : a successor node connected to a node is called child. A node in binary tree may have at most two children.
- Parent : a node is said to be parent node to all its child nodes.
- Leaf : a node that has no child nodes.
- Siblings : Two nodes are siblings if they are children to the same parent node.

Tree – Basic Terminology Contd...

- **Ancestor** : a node which is parent of parent node (A is ancestor node to D,E and F).
- **Descendent** : a node which is child of child node (D, E and F are descendent nodes of node A)
- **Level** : The distance of a node from the root node, The root is at level – 0,(B and C are at Level 1 and D, E, F have Level 2 (highest level of tree is called height of tree)
- **Degree** : The number of nodes connected to a particular parent node.

Binary Tree

- **A binary tree is a hierarchy of nodes, where every parent node has at most two child nodes. There is a unique node, called the root, that does not have a parent.**
- **A binary tree can be defined recursively as**
- **Root node**
- **Left subtree: left child and all its descendants**
- **Right subtree: right child and all its descendants**

Binary Tree

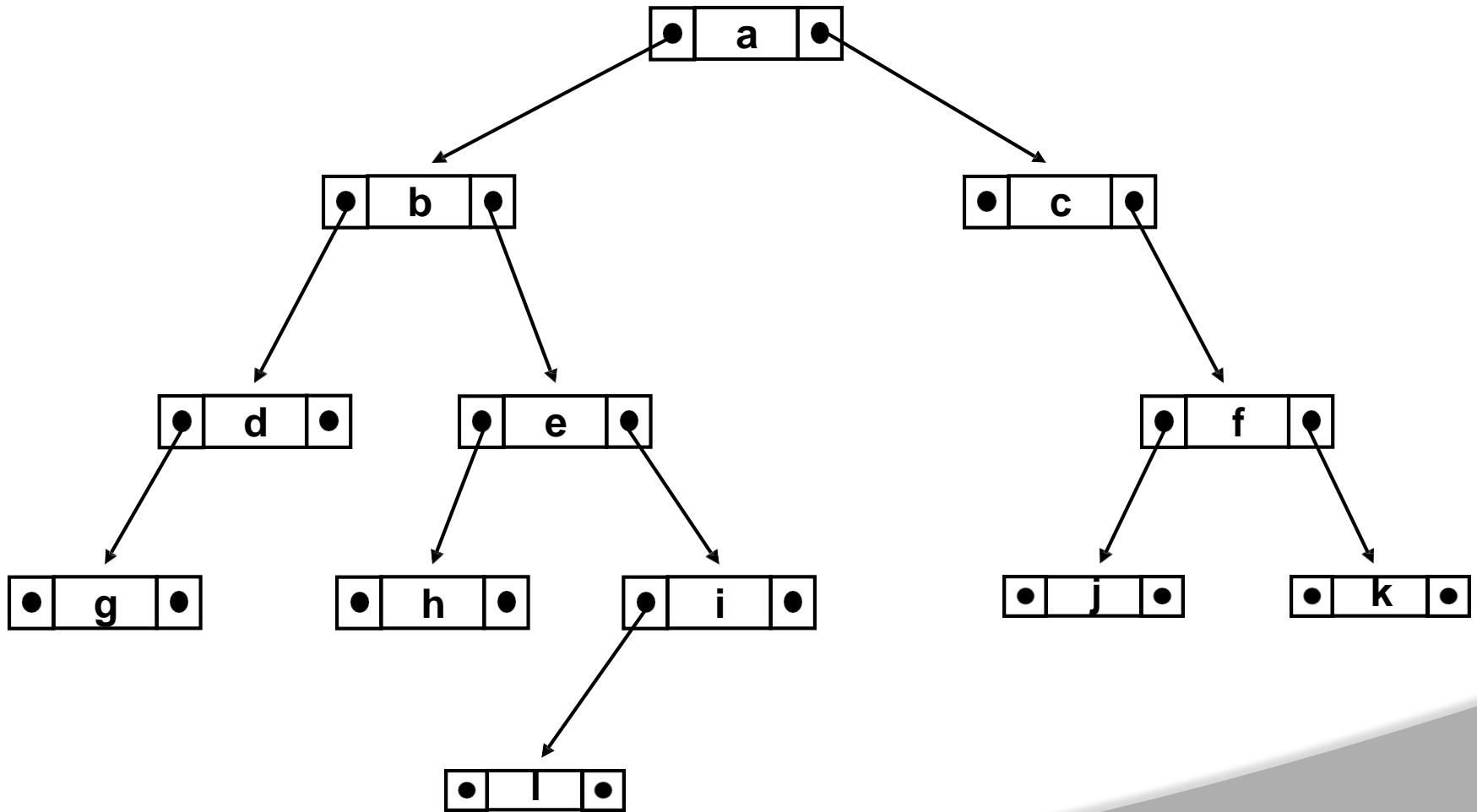

Full and Complete Binary Trees

- A full tree is a binary tree in which
 - Number of nodes at level l is 2^{l-1}
 - Total nodes in a full tree of height n is
- A complete tree of height n is a binary tree
 - Number of nodes at level l is 2^{l-1} for $l < n-1$
 - Leaf nodes at level n occupy the leftmost positions in the tree

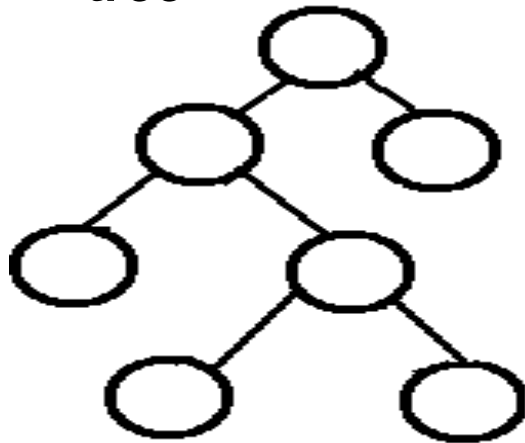

full tree

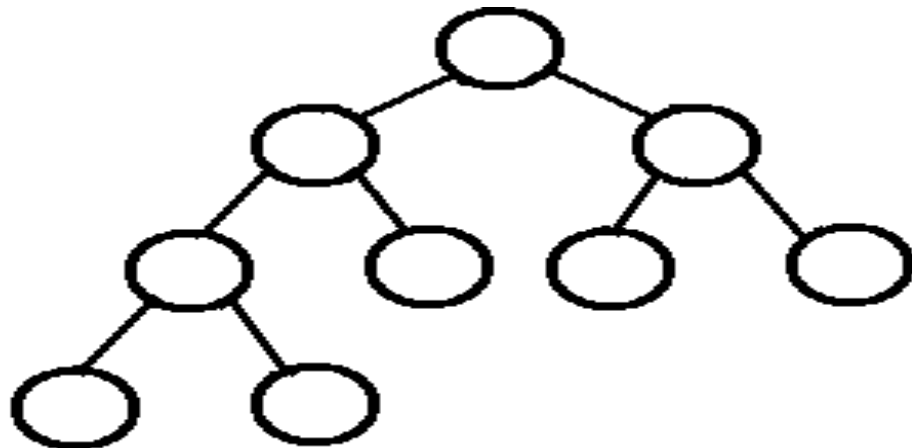

complete tree

Tree Traversals

- **A binary tree is defined recursively: it consists of a root, a left subtree, and a right subtree.**
- **To traverse (or walk) the binary tree is to visit each node in the binary tree exactly once.**
- **Tree traversals are naturally recursive.**
- **Standard traversal orderings:**
 - preorder
 - inorder
 - postorder
 - level-order

Preorder, Inorder, Postorder

- In Preorder, the root is visited before (pre)

the subtrees traversals.

- In Inorder, the root is visited in-between left and right subtree traversal.

- In Postorder, the root is visited after (pre) the subtrees traversals.

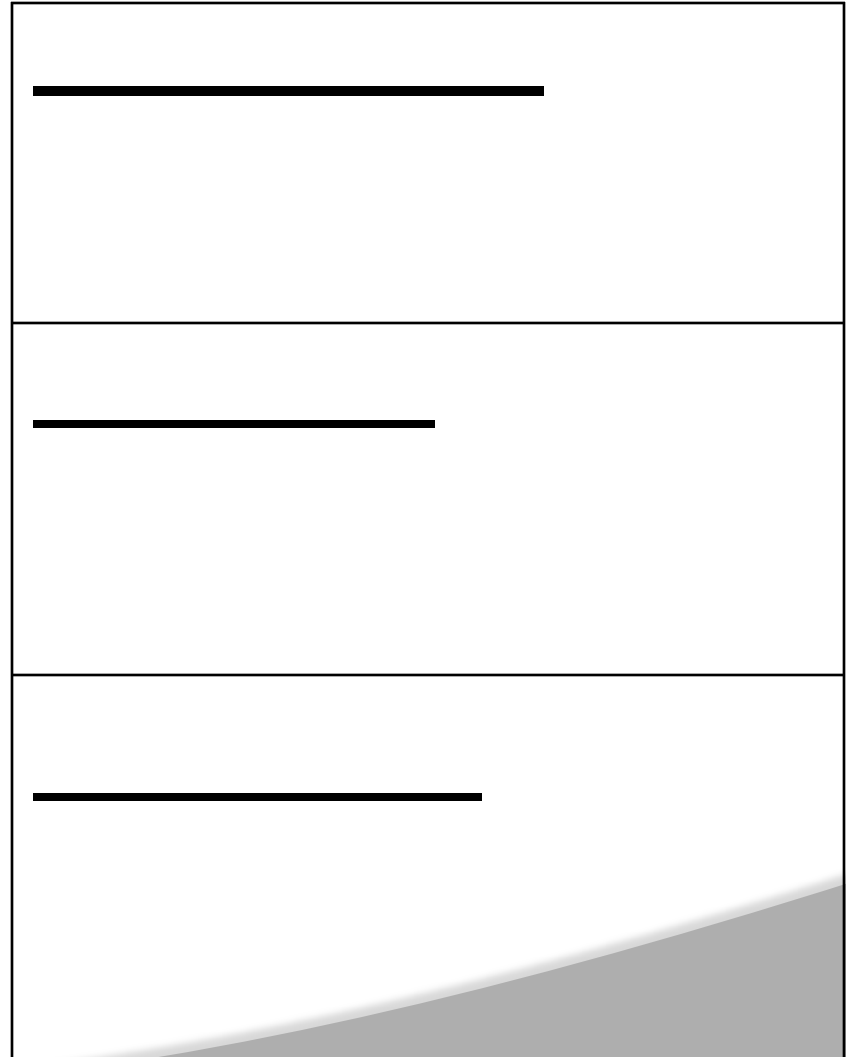

Example of Tree Traversal

- Assume: visiting a node
is printing its data

- Preorder: 15 8 2 6 3 7
11 10 12 14 20 27 22 30
- Inorder: 2 3 6 7 8 10 11
12 14 15 20 22 27 30
- Postorder: 3 7 6 2 10 14
12 11 8 22 30 27 20 15

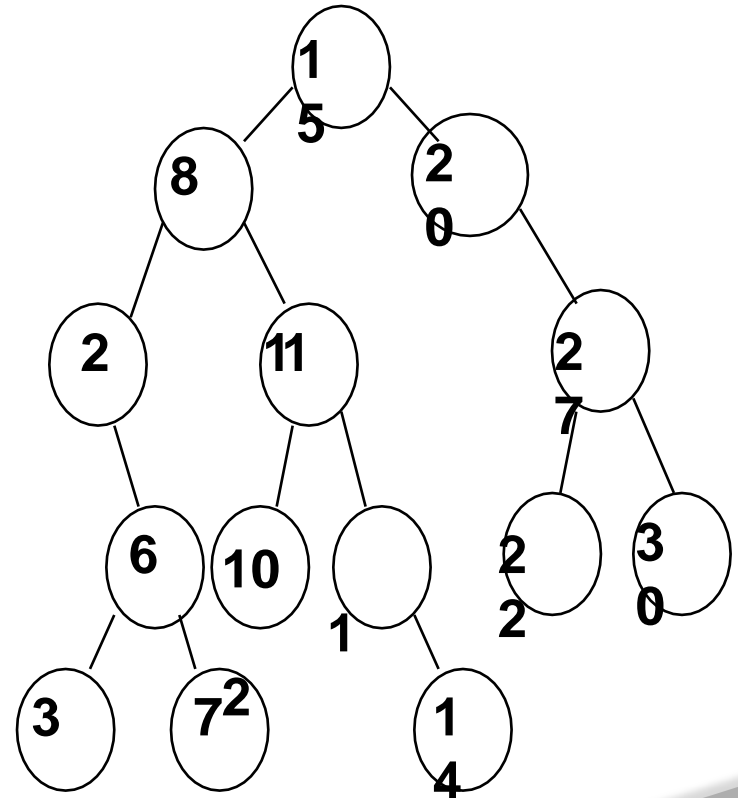

Traversal Techniques

```
void preorder(tree *tree) {  
    if (tree->isEmpty( )) return; visit(tree->getRoot( )); preorder(tree->  
    >getLeftSubtree()); preorder(tree->getRightSubtree());  
}
```

```
void inOrder(Tree *tree){  
    if (tree->isEmpty( )) return; inOrder(tree->getLeftSubtree( ));  
    visit(tree->getRoot( )); inOrder(tree->getRightSubtree( ));  
}
```

```
void postOrder(Tree *tree){  
    if (tree->isEmpty( )) return; postOrder(tree->getLeftSubtree( ));  
    postOrder(tree->getRightSubtree( )); visit(tree->getRoot( ));  
}
```

Threaded Binary Tree

- A threaded binary tree defined as:
- "A binary tree is threaded by making all right child pointers that would normally be null point to the inorder successor of the node, and all left child pointers that would normally be null point to the inorder predecessor of the node

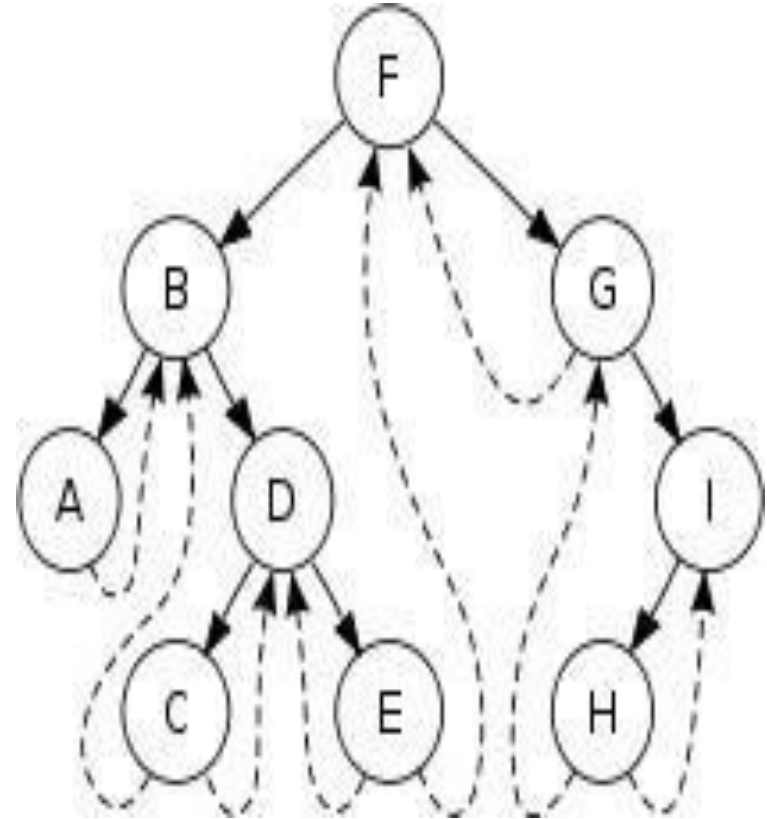

Graph Basics

- **Graphs are collections of nodes connected by edges – $G = (V,E)$ where V is a set of nodes and E a set of edges.**
- **Graphs are useful in a number of applications including**
 - **Shortest path problems**
 - **Maximum flow problems**
- **Graphs unlike trees are more general for they can have connected components.**

Graph Types

Directed Graphs: A directed graph edges allow travel in one direction.

• **Undirected Graphs:** An undirected graph edges allow travel in either direction.

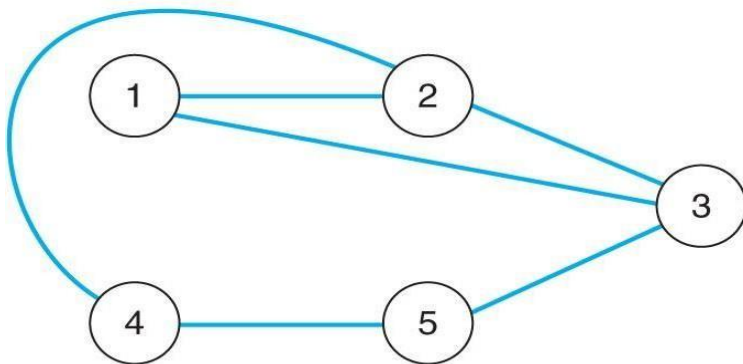

■ FIGURE 8.1A

The graph $G = (\{1, 2, 3, 4, 5\}, \{\{1, 2\}, \{1, 3\}, \{2, 3\}, \{2, 4\}, \{3, 5\}, \{4, 5\}\})$

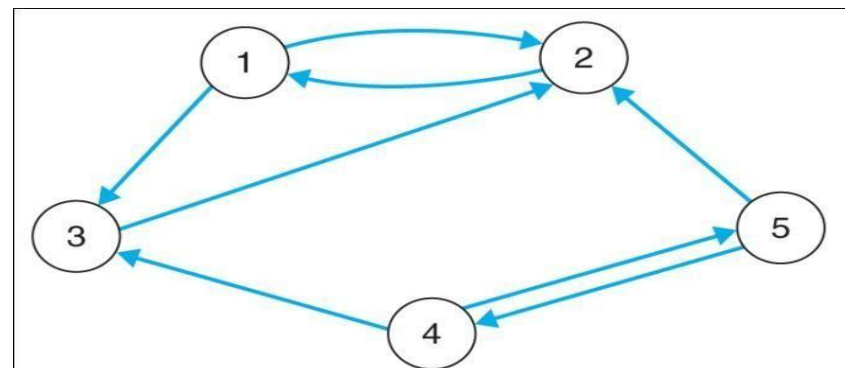

■ FIGURE 8.1B

The directed graph $G = (\{1, 2, 3, 4, 5\}, \{(1, 2), (2, 1), (1, 3), (3, 2), (2, 4), (4, 3), (4, 5), (5, 2), (5, 4)\})$

Graph Terminology

- **A graph is an ordered pair $G=(V,E)$ with a set of vertices or nodes and the edges that connect them.**
- **A subgraph of a graph has a subset of the vertices and edges.**
- **The edges indicate how we can move through the graph.**
- **A path is a subset of E that is a series of edges between two nodes.**
- **A graph is connected if there is at least one path between every pair of nodes.**

Graph Terminology

- **The length of a path in a graph is the number of edges in the path.**
- **A complete graph is one that has an edge between every pair of nodes.**
- **A weighted graph is one where each edge has a cost for traveling between the nodes.**
- **A cycle is a path that begins and ends at the same node.**
- **An acyclic graph is one that has no cycles.**
- **An acyclic, connected graph is also called an unrooted tree**

Data Structures for Graphs An Adjacency Matrix



- For an undirected graph, the matrix will be symmetric along the diagonal.
- For a weighted graph, the adjacency matrix would have the weight for edges in the graph, zeros along the diagonal, and infinity (∞) every place else.

Adjacency Matrix Example 1

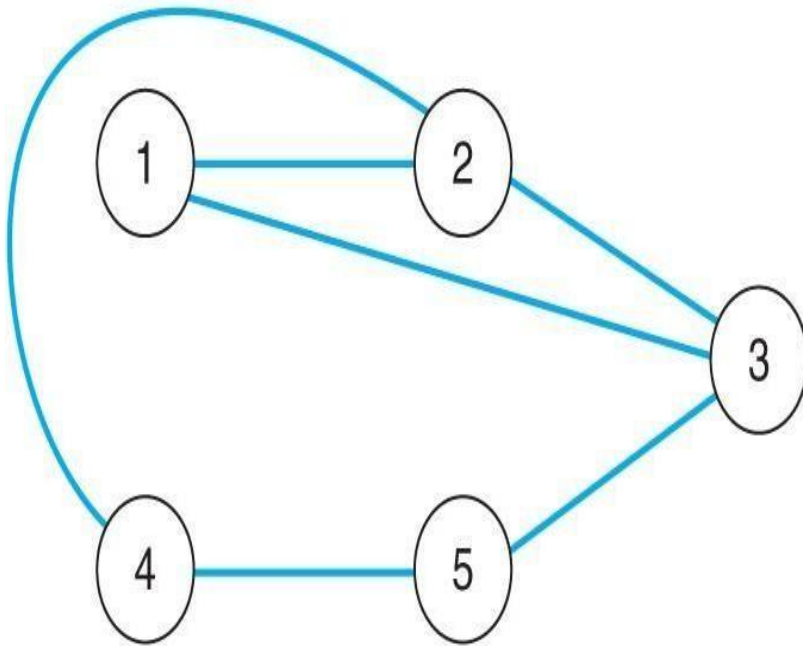

■ FIGURE 8.1A

The graph $G = (\{1, 2, 3, 4, 5\}, \{\{1, 2\}, \{1, 3\}, \{2, 3\}, \{2, 4\}, \{3, 5\}, \{4, 5\}\})$

	1	2	3	4	5
1	0	1	1	0	0
2	1	0	1	1	0
3	1	1	0	0	1
4	0	1	0	0	1
5	0	0	1	1	0

■ FIGURE 8.2A

The adjacency matrix for the graph in Fig. 8.1(a)

Adjacency Matrix Example 2

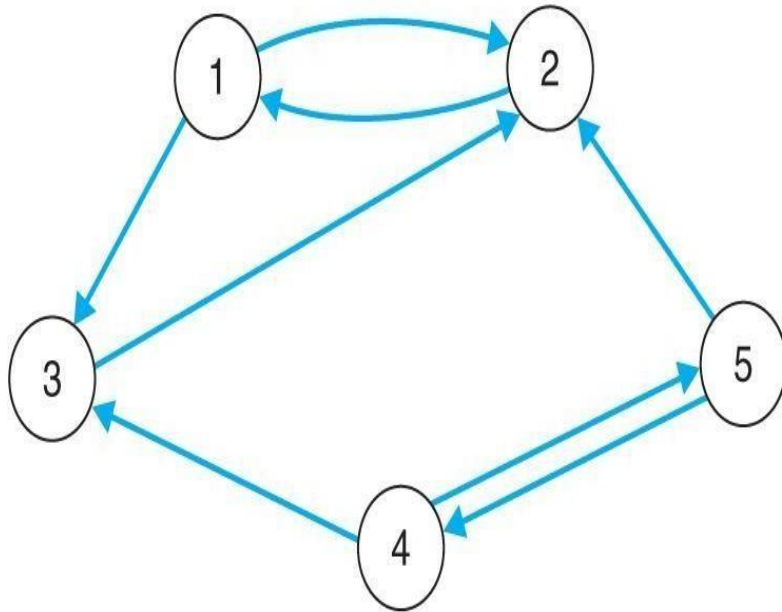

■ FIGURE 8.1B

The directed graph $G = (\{1, 2, 3, 4, 5\}, \{(1, 2), (1, 3), (2, 1), (3, 2), (4, 3), (4, 5), (5, 2), (5, 4)\})$

	1	2	3	4	5
1	0	1	1	0	0
2	1	0	0	0	0
3	0	1	0	0	0
4	0	0	1	0	1
5	0	1	0	1	0

■ FIGURE 8.2B

The adjacency matrix for the digraph in Fig. 8.1(b)

Data Structures for Graphs An Adjacency List

- **A list of pointers, one for each node of the graph.**
- **These pointers are the start of a linked list of nodes that can be reached by one edge of the graph.**
- **For a weighted graph, this list would also include the weight for each edge.**

Adjacency List Example 1

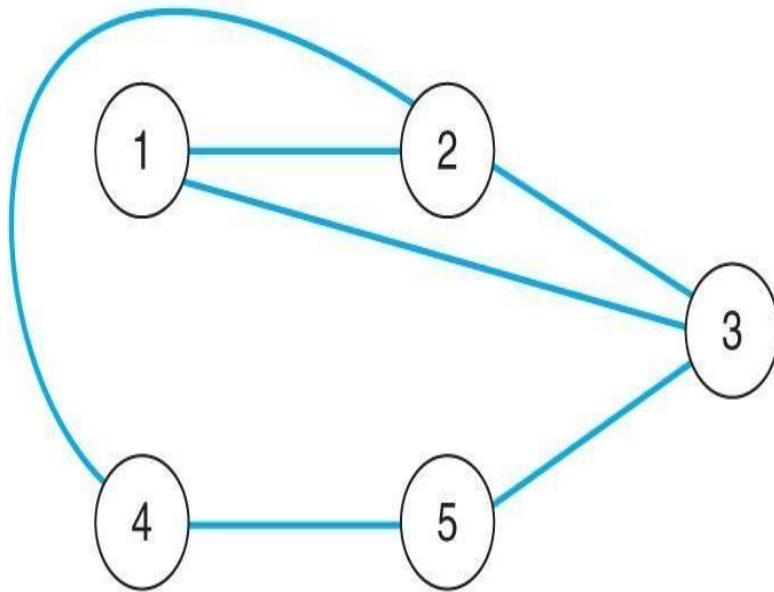

■ **FIGURE 8.1A**

The graph $G = (\{1, 2, 3, 4, 5\}, \{\{1, 2\}, \{1, 3\}, \{2, 3\}, \{2, 4\}, \{3, 5\}, \{4, 5\}\})$

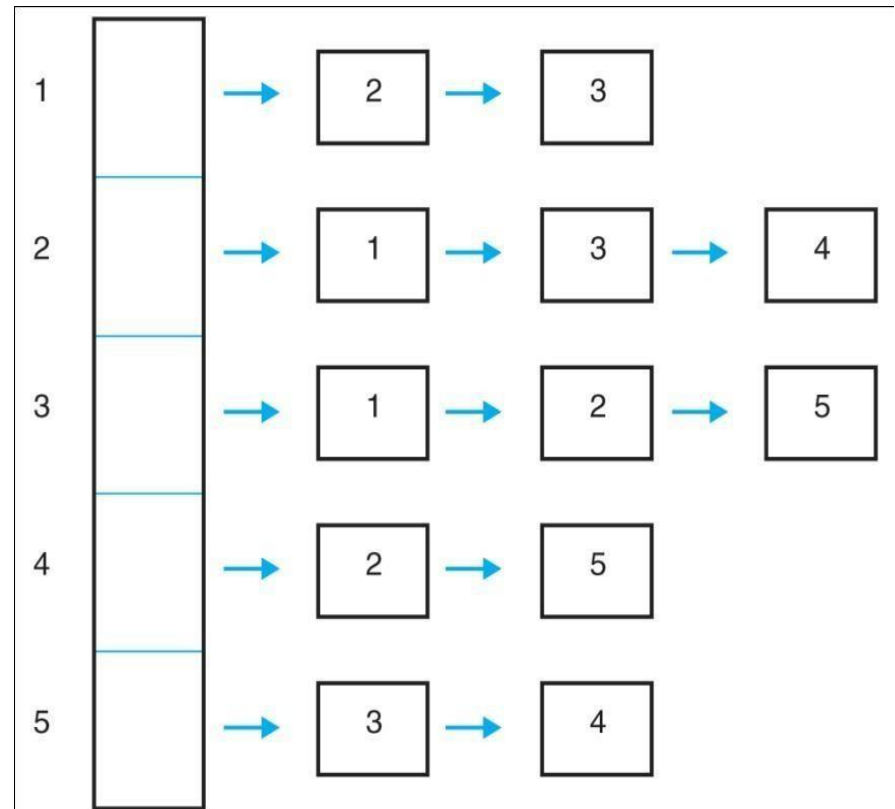

■ **FIGURE 8.3A**

The adjacency list for the graph in Fig. 8.1(a)

Adjacency List Example 2

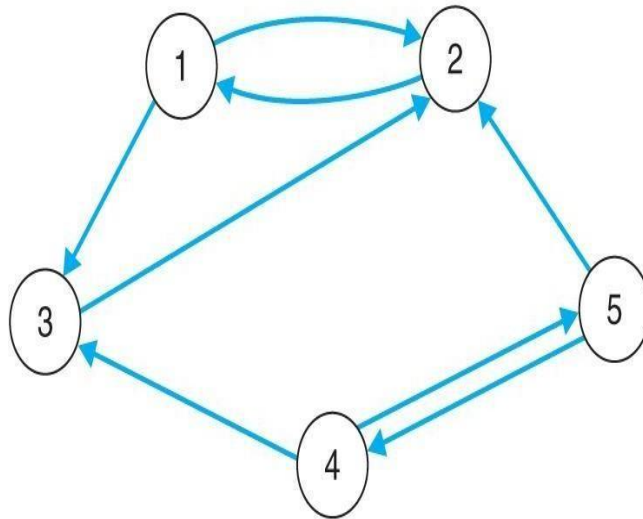

■ **FIGURE 8.1B**

The directed graph $G = (\{1, 2, 3, 4, 5\}, \{(1, 2), (1, 3), (2, 1), (3, 2), (4, 3), (4, 5), (5, 2), (5, 4)\})$

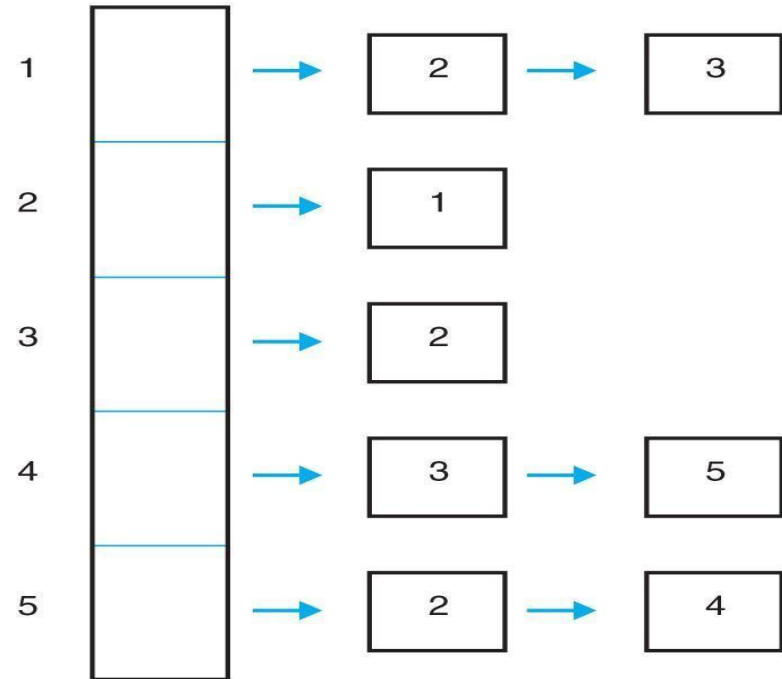

■ **FIGURE 8.3B**

The adjacency list for the graph in Fig. 8.1(b)

Graph Traversals

- **Some algorithms require that every vertex of a graph be visited exactly once.**
- **The order in which the vertices are visited may be important, and may depend upon the particular algorithm.**
- **The two common traversals:**
 - **depth-first**
 - **breadth-first**

Graph Traversals: Depth First Search Traversal



- **We follow a path through the graph until we reach a dead end.**
- **We then back up until we reach a node with an edge to an unvisited node.**
- **We take this edge and again follow it until we reach a dead end.**
- **This process continues until we back up to the starting node and it has no edges to unvisited nodes.**

Depth First Search Traversal Example

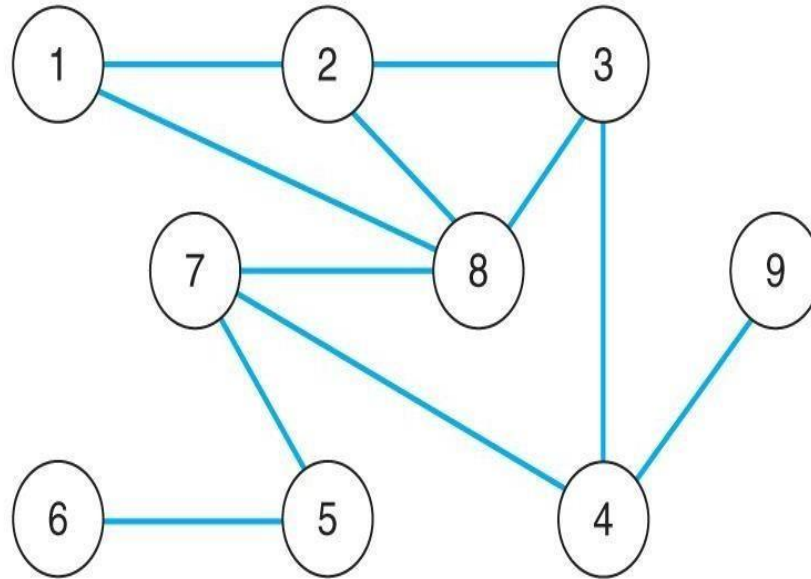

■ **FIGURE 8.4**
A graph

Breadth First Search Traversal

- **From the starting node, we follow all paths of length one.**
- **Then we follow paths of length two that go to unvisited nodes.**
- **We continue increasing the length of the paths until there are no unvisited nodes along any of the paths.**

Breadth First Search Traversal Example

- Consider the following graph:

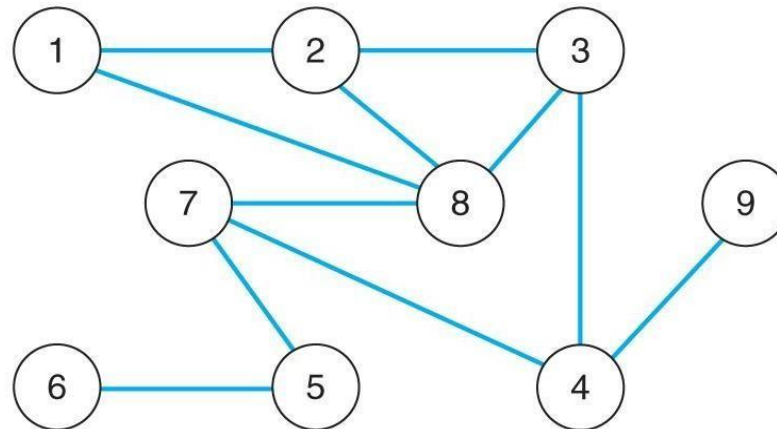

■ FIGURE 8.4
A graph

- The order of the breadth-first traversal of this graph starting at node 1 would be: 1, 2, 8, 3, 7, 4, 5, 9, 6

MODULE – V

BINARY TREES AND HASHING

Binary Search Trees

- In a BST, each node stores some information including a unique key value, and perhaps some associated data. A binary tree is a BST iff, for every node n in the tree:
 - All keys in n 's left subtree are less than the key in n , and
 - All keys in n 's right subtree are greater than the key in n .
- In other words, binary search trees are binary trees in which all values in the node's left subtree are less than node value all values in the node's right subtree are greater than node value.

BST Example

Here are some BSTs in which each node just stores an integer key.

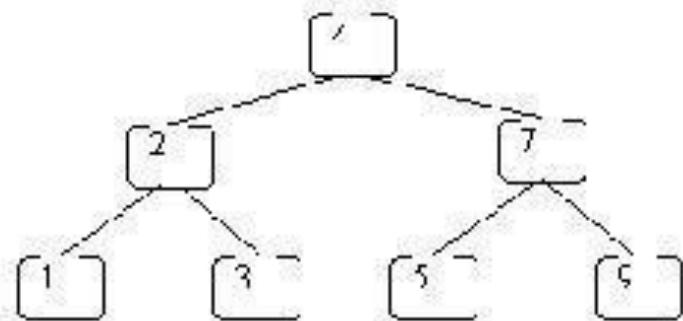
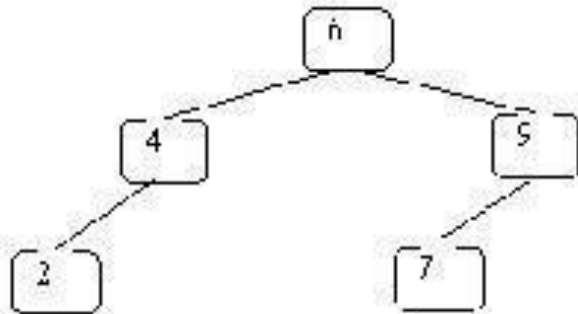

These are not BSTs:

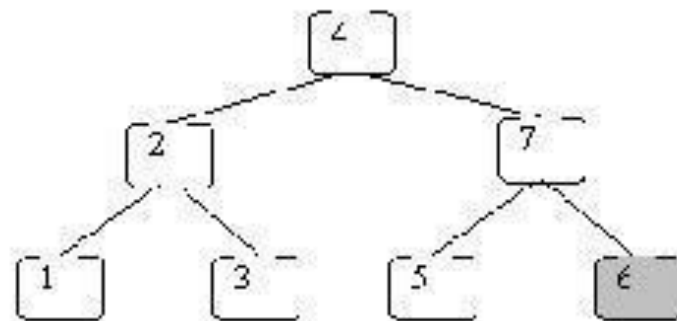
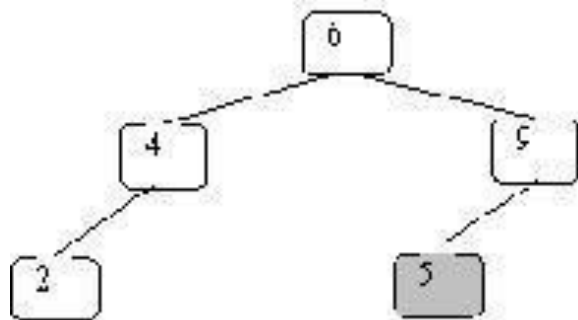

In the left one 5 is not greater than 6. In the right one 6 is not greater than 7.

A BST is a binary tree of nodes ordered in the following way:

- i. Each node contains one key (also unique)**
- ii. The keys in the left subtree are $<$ (less) than the key in its parent node**
- iii. The keys in the right subtree $>$ (greater) than the key in its parent node**
- iv. Duplicate node keys are not allowed.**

Operations - Inserting a node



- A naïve algorithm for inserting a node into a BST is that, we start from the root node, if the node to insert is less than the root, we go to left child, and otherwise we go to the right child of the root.
- We then insert the node as a left or right child of the leaf node based on node is less or greater than the leaf node. We note that a new node is always inserted as a leaf node.

- A recursive algorithm for inserting a node into a BST is as follows. Assume we insert a node N to tree T. if the tree is empty, then we return new node N as the tree. Otherwise, the problem of inserting is reduced to inserting the node N to left or right sub trees of T, depending on N is less or greater than T. A definition is as follows.

Insert(N, T) = N if T is empty
 = insert(N, T.left) if N < T
 = insert(N, T.right) if N > T

- **Searching for a node is similar to inserting a node. We start from root, and then go left or right until we find (or not find the node). A recursive definition of search is as follows. If the node is equal to root, then we return true. If the root is null, then we return false. Otherwise we recursively solve the problem for T.left or T.right, depending on $N < T$ or $N > T$. A recursive definition is as follows.**
- **Search should return a true or false, depending on the node is found or not.**

- **Search(N, T) = false if T is empty** Searching for a node is similar to inserting a node. We start from root, and then go left or right until we find (or not find the node).
- **A recursive definition of search is as follows.** If the node is equal to root, then we return true. If the root is null, then we return false. Otherwise we recursively solve the problem for T.left or T.right, depending on $N < T$ or $N > T$. A recursive definition is as follows.
- **Search should return a true or false, depending on the node is found or not.**

Search(N, T) = false if T is empty
= true if T = N
= search(N, T.left) if $N < T$

Operations - Deleting a node

- A BST is a connected structure. That is, all nodes in a tree are connected to some other node. For example, each node has a parent, unless node is the root. Therefore deleting a node could affect all sub trees of that node. For example, deleting node 5 from the tree could result in losing sub trees that are rooted at 1 and 9.

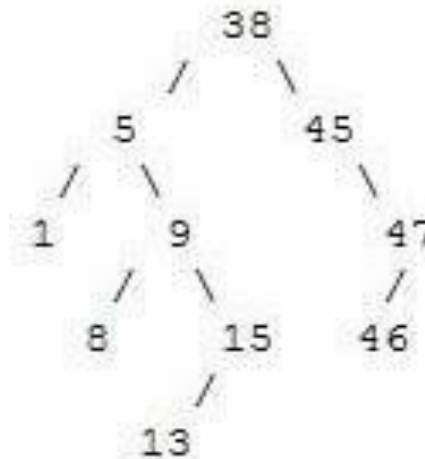

Balanced Search Trees

- **A self-balancing (or height-balanced) binary search tree is any node-based binary search tree that automatically keeps its height (maximal number of levels below the root) small in the face of arbitrary item insertions and deletions.**
- **AVL Trees: An AVL tree is another balanced binary search tree. Named after their inventors, Adelson-Velskii and Landis, they were the first dynamically balanced trees to be proposed. Like red-black trees, they are not perfectly balanced, but pairs of sub-trees differ in height by at most 1, maintaining an $O(\log n)$ search time. Addition and deletion operations also take $O(\log n)$ time.**

AVL Tree - Definition

- Definition of an AVL tree: An AVL tree is a binary search tree which has the following properties:
 - i. The sub-trees of every node differ in height by at most one.
 - ii. Every sub-tree is an AVL tree.
- Balance requirement for an AVL tree: the left and right sub-trees differ by at most 1 in height.

Balance requirement for an AVL tree: the left and right sub-trees differ by at most 1 in height.

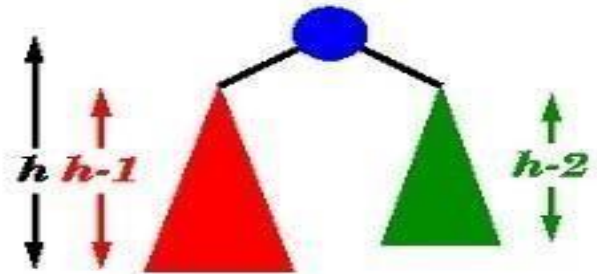

For example, here are some trees:

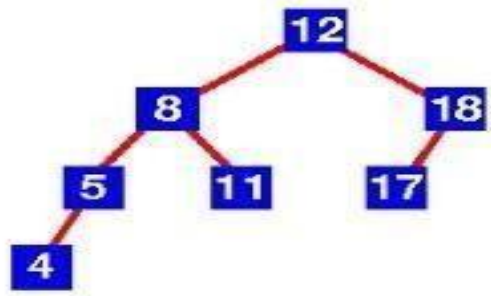

Yes this is an AVL tree. Examination shows that *each* left sub-tree has a height 1 greater than each right sub-tree.

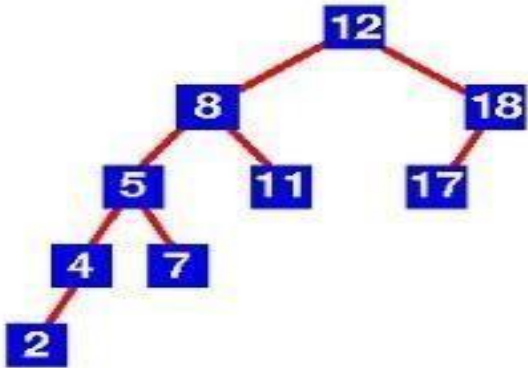

No this is not an AVL tree. Sub-tree with root 8 has height 4 and sub-tree with root 18 has height 2.

Balance Factor

- To implement our AVL tree we need to keep track of a balance factor for each node in the tree. We do this by looking at the heights of the left and right subtrees for each node. More formally, we define the balance factor for a node as the difference between the height of the left subtree and the height of the right subtree.

$$\text{balanceFactor} = \text{height}(\text{leftSubTree}) - \text{height}(\text{rightSubTree})$$

- Using the definition for balance factor given above we say that a subtree is left-heavy if the balance factor is greater than zero. If the balance factor is less than zero then the subtree is right heavy. If the balance factor is zero then the tree is perfectly in balance.

Balance Factor

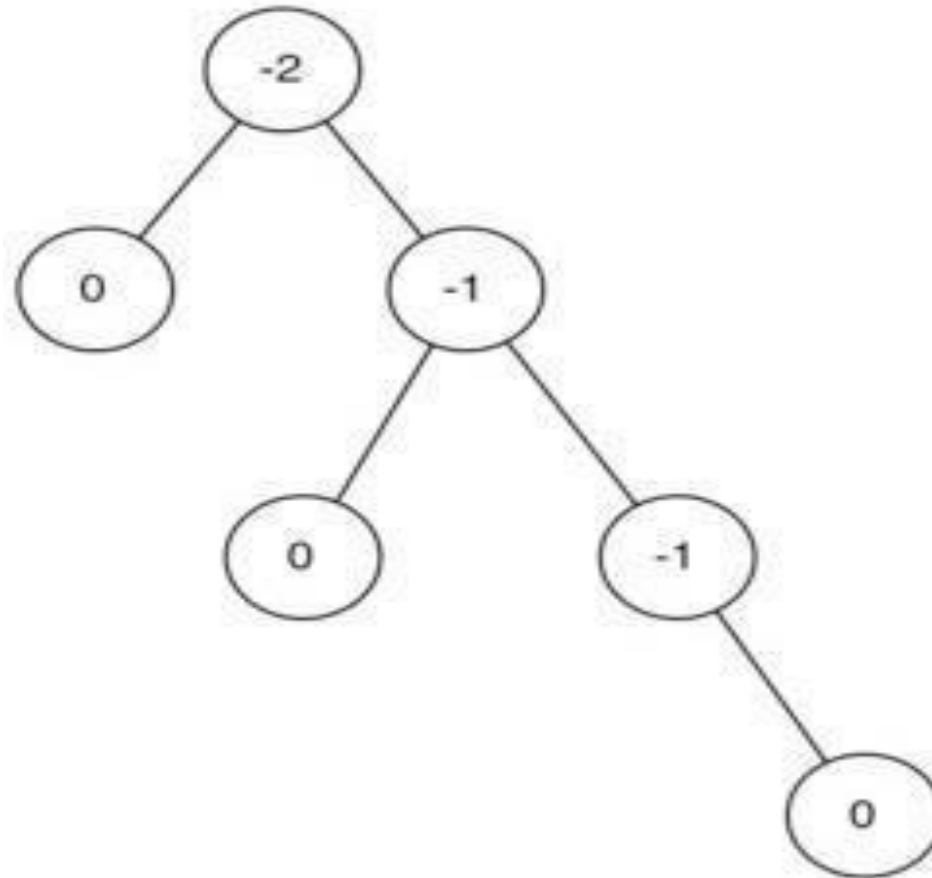

Introduction to M-Way Search Trees

- A multiway tree is a tree that can have more than two children. A multiway tree of order m (or an m -way tree) is one in which a tree can have m children.
- As with the other trees that have been studied, the nodes in an m -way tree will be made up of key fields, in this case $m-1$ key fields, and pointers to children.
- Multiday tree of order 5

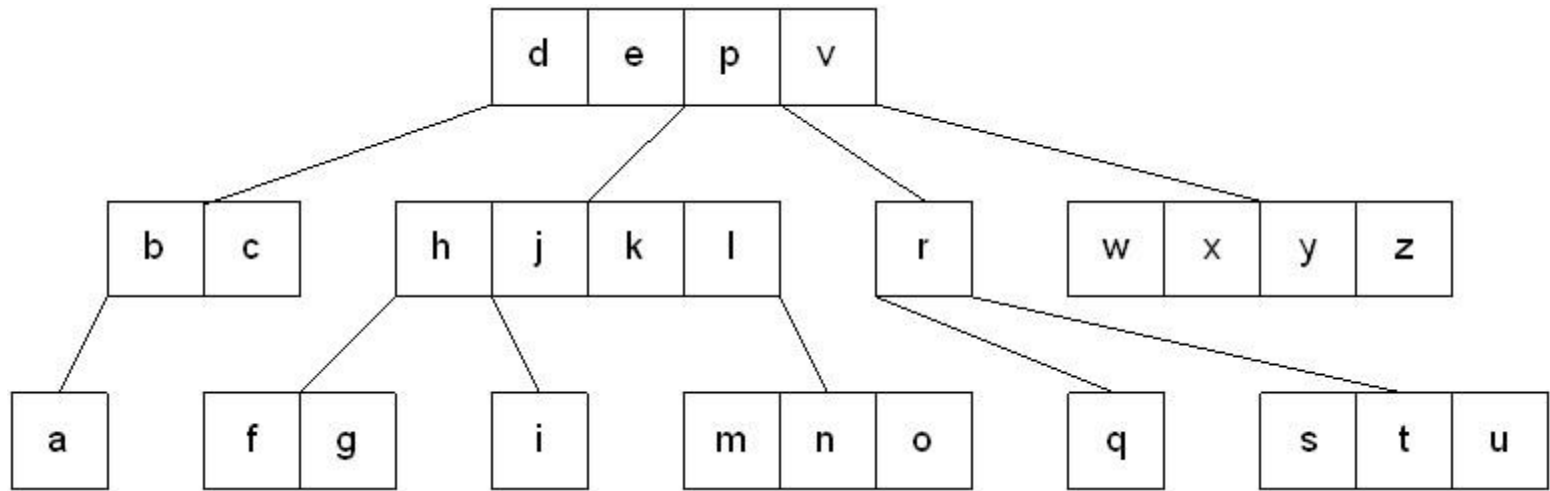

Properties of M-way Search Trees

- **m-way search tree is a m-way tree in which:**
 - Each node has m children and m-1 key fields**
 - The keys in each node are in ascending order.**
 - The keys in the first i children are smaller than the ith key**
 - The keys in the last m-i children are larger than the ith key**
- **4-way search tree**

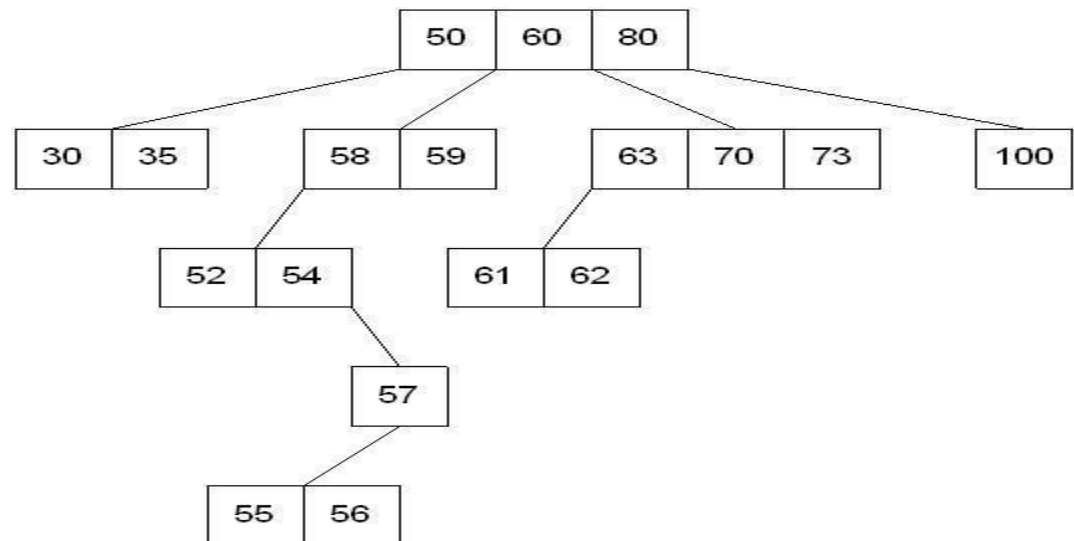

B -Trees

- **An extension of a multiway search tree of order m is a B- tree of order m . This type of tree will be used when the data to be accessed/stored is located on secondary storage devices because they allow for large amounts of data to be stored in a node.**
- **A B-tree of order m is a multiway search tree inwhich:**
 - The root has at least two subtrees unless it is the only node in the tree.**
 - Each nonroot and each nonleaf node have at most m nonempty children and at least $m/2$ nonempty children.**
 - The number of keys in each nonroot and each nonleaf node is one less than the number of its nonempty children.**
 - All leaves are on the same level.**

Searching a B -Tree



- **Start at the root and determine which pointer to follow based on a comparison between the search value and key fields in the root node.**
- **Follow the appropriate pointer to a child node.**
- **Examine the key fields in the child node and continue to follow the appropriate pointers until the search value is found or a leaf node is reached that doesn't contain the desired search value.**

Insertion into a B-Tree

- **The condition that all leaves must be on the same level forces a characteristic behavior of B-trees, namely that B-trees are not allowed to grow at the their leaves; instead they are forced to grow at the root.**
- **When inserting into a B-tree, a value is inserted directly into a leaf. This leads to three common situations that can occur:**
 - i. A key is placed into a leaf that still has room.**
 - ii. The leaf in which a key is to be placed is full.**
 - iii. The root of the B-tree is full.**

Case 1: A key is placed into a leaf that still has room

This is the easiest of the cases to solve because the value is simply inserted into the correct sorted position in the leaf node.

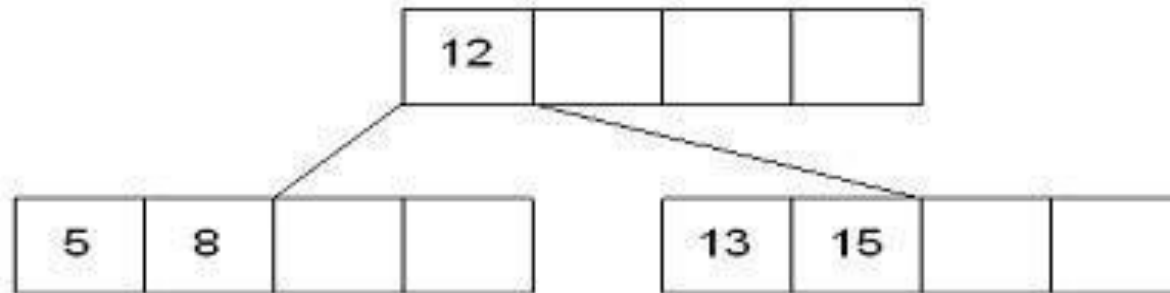

Inserting the number 7 results in:

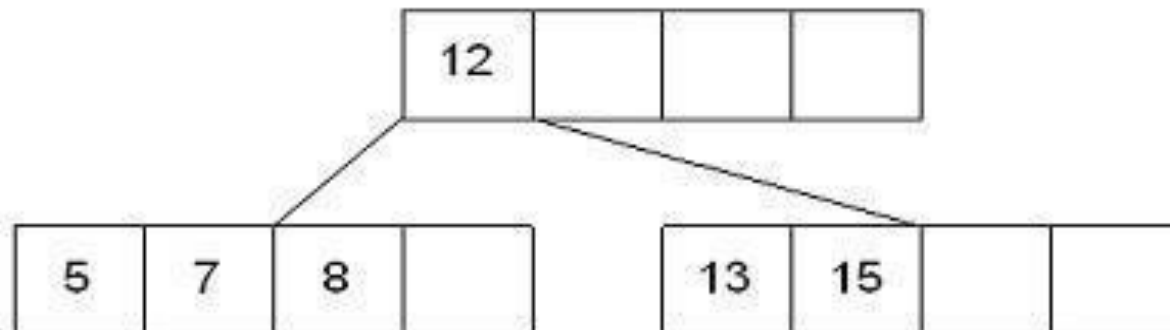

Case 2: The leaf in which a key is to be placed is full

In this case, the leaf node where the value should be inserted is split in two, resulting in a new leaf node. Half of the keys will be moved from the full leaf to the new leaf. The new leaf is then incorporated into the B-tree.

The new leaf is incorporated by moving the middle value to the parent and a pointer to the new leaf is also added to the parent. This process is continued up the tree until all of the values have "found" a location.

Insert 6 into the following B-tree:

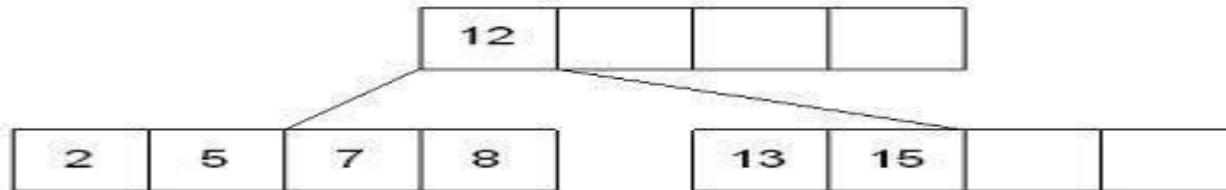

results in a split of the first leaf node:

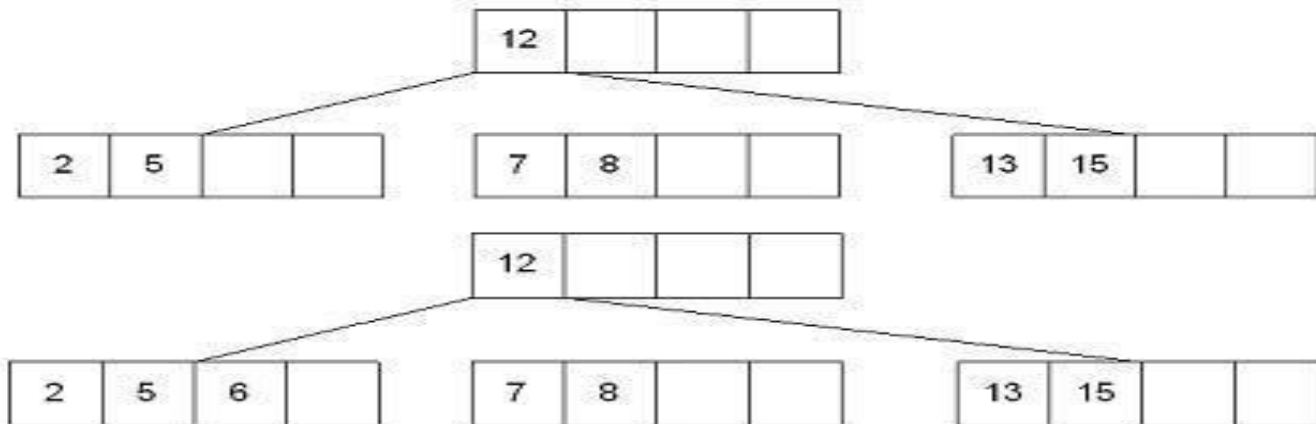

The new node needs to be incorporated into the tree - this is accomplished by taking the middle value and inserting it in the parent:

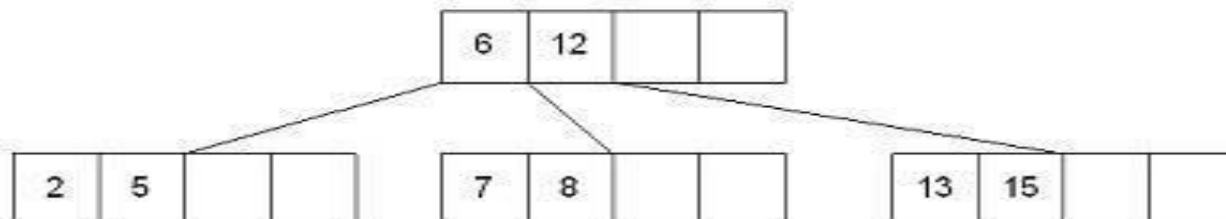

Case 3: The root of the B-tree is full

The upward movement of values from case 2 means that it's possible that a value could move up to the root of the B-tree. If the root is full, the same basic process from case 2 will be applied and a new root will be created. This type of split results in 2 new nodes being added to the B-tree.

Inserting 13 into the following tree:

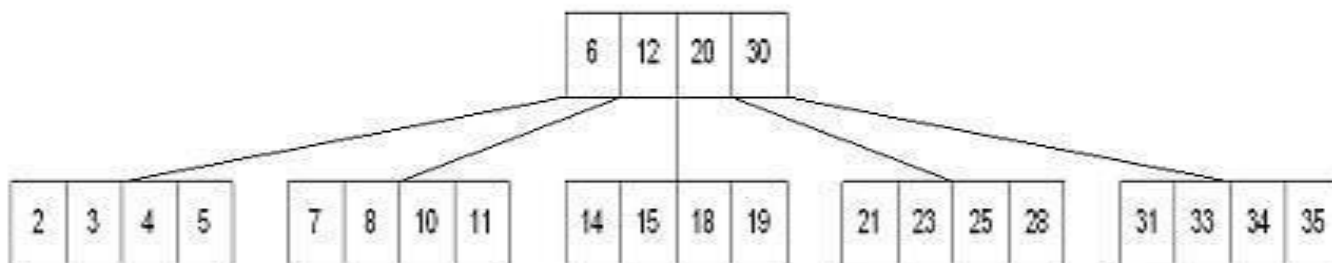

Results in:

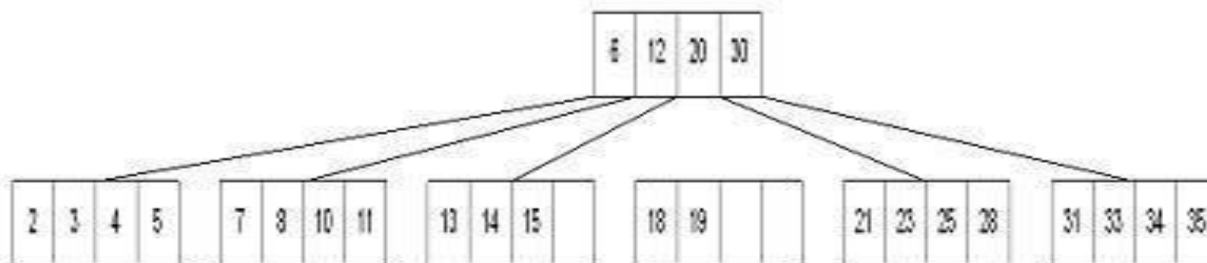

The 15 needs to be moved to the root node but it is full. This means that the root needs to be divided:

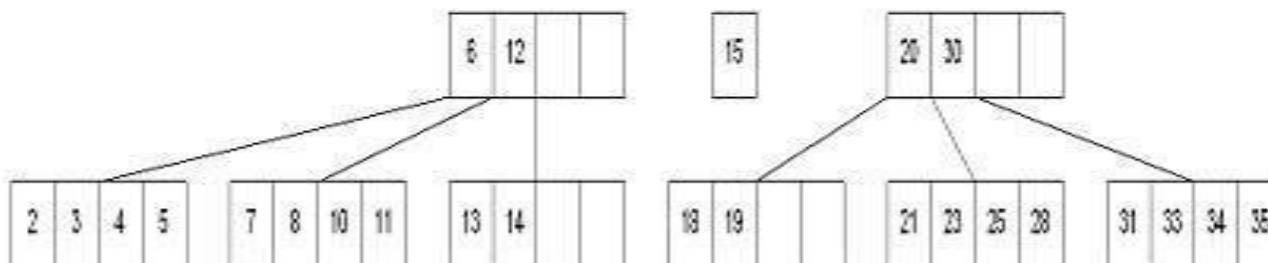

The 15 is inserted into the parent, which means that it becomes the new root node:

Deleting from a B-Tree

- The deletion process will basically be a reversal of the insertion process - rather than splitting nodes, it's possible that nodes will be merged so that B-tree properties, namely the requirement that a node must be at least half full, can be maintained.
- There are two main cases to be considered:
 - i. Deletion from a leaf
 - ii. Deletion from a non-leaf

Case 1: Deletion from a leaf

1a) If the leaf is at least half full after deleting the desired value, the remaining larger values are moved to "fill the gap".

Deleting 6 from the following tree:

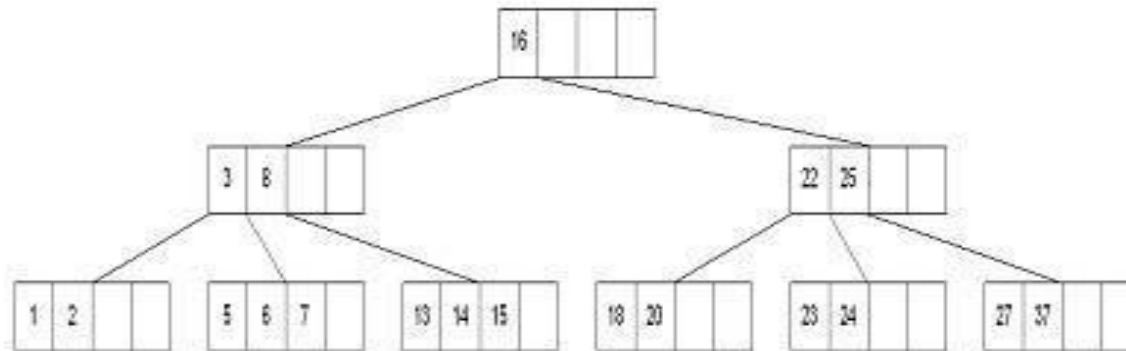

results in:

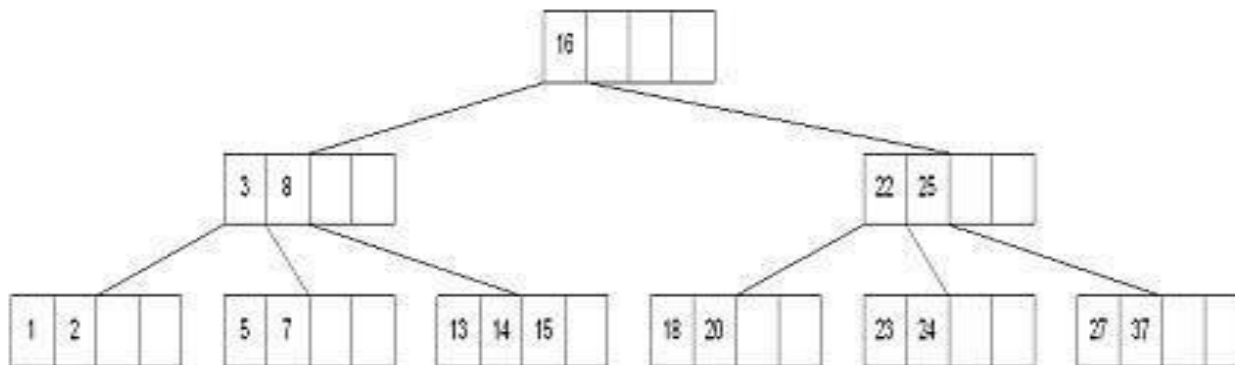

If there is a left or right sibling with the number of keys exceeding the minimum requirement, all of the keys from the leaf and sibling will be redistributed between them by moving the separator key from the parent to the leaf and moving the middle key from the node and the sibling combined to the parent.

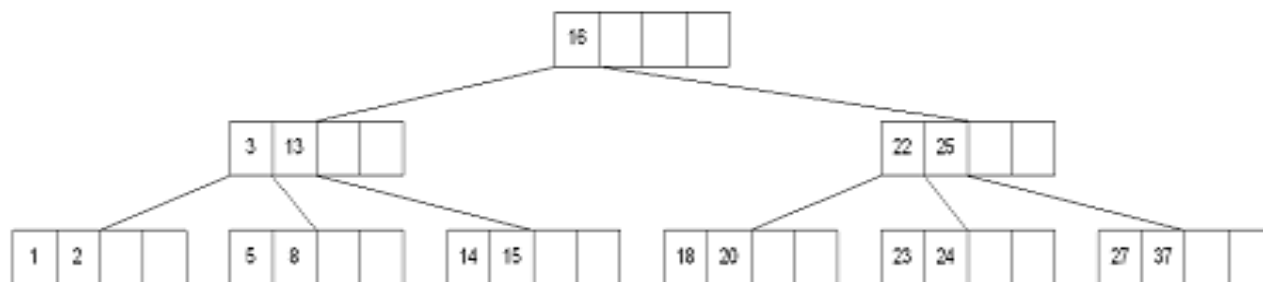

Now delete 8 from the tree:

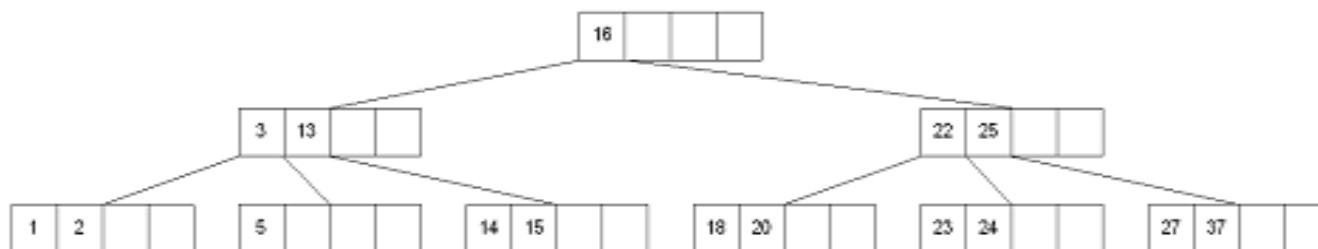

If the number of keys in the sibling does not exceed the minimum requirement, then the leaf and sibling are merged by putting the keys from the leaf, the sibling, and the separator from the parent into the leaf. The sibling node is discarded and the keys in the parent are moved to "fill the gap". It's possible that this will cause the parent to underflow. If that is the case, treat the parent as a leaf and continue repeating step 1b-2 until the minimum requirement is met or the root of the tree is reached.

Hashing

- Hashing is the technique used for performing almost constant time search in case of insertion, deletion and find operation.
- Taking a very simple example of it, an array with its index as key is the example of hash table. So each index (key) can be used for accessing the value in a constant search time. This mapping key must be simple to compute and must help in identifying the associated value. Function which helps us in generating such kind of key-value mapping is known as Hash Function.
- In a hashing system the keys are stored in an array which is called the Hash Table. A perfectly implemented hash table would always promise an average insert/ delete / retrieval time of $O(1)$.

Hashing Function

- A function which employs some algorithm to compute the key K for all the data elements in the set U , such that the key K which is of a fixed size. The same key K can be used to map data to a hash table and all the operations like insertion, deletion and searching should be possible. The values returned by a hash function are also referred to as hash values, hash codes, hash sums, or hashes.

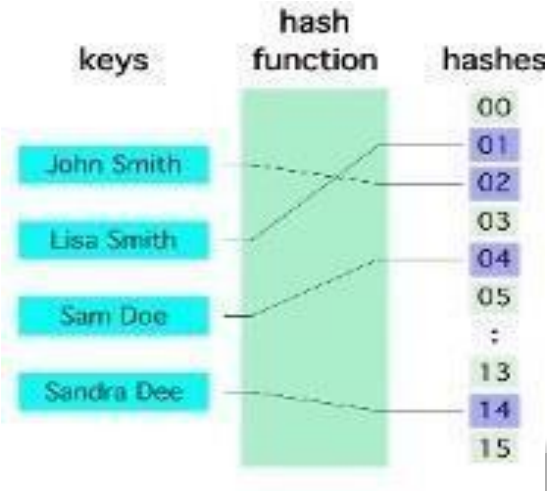

Hash Collision

A situation when the resultant hashes for two or more data elements in the data set U , maps to the same location in the hash table, is called a hash collision. In such a situation two or more data elements would qualify to be stored / mapped to the same location in the hash table.

- **Hash collision resolution techniques:**
- **Open Hashing (Separate chaining):** Open Hashing, is a technique in which the data is not directly stored at the hash key index (k) of the Hash table. Rather the data at the key index (k) in the hash table is a pointer to the head of the data structure where the data is actually stored. In the most simple and common implementations the data structure adopted for storing the element is a linked-list.

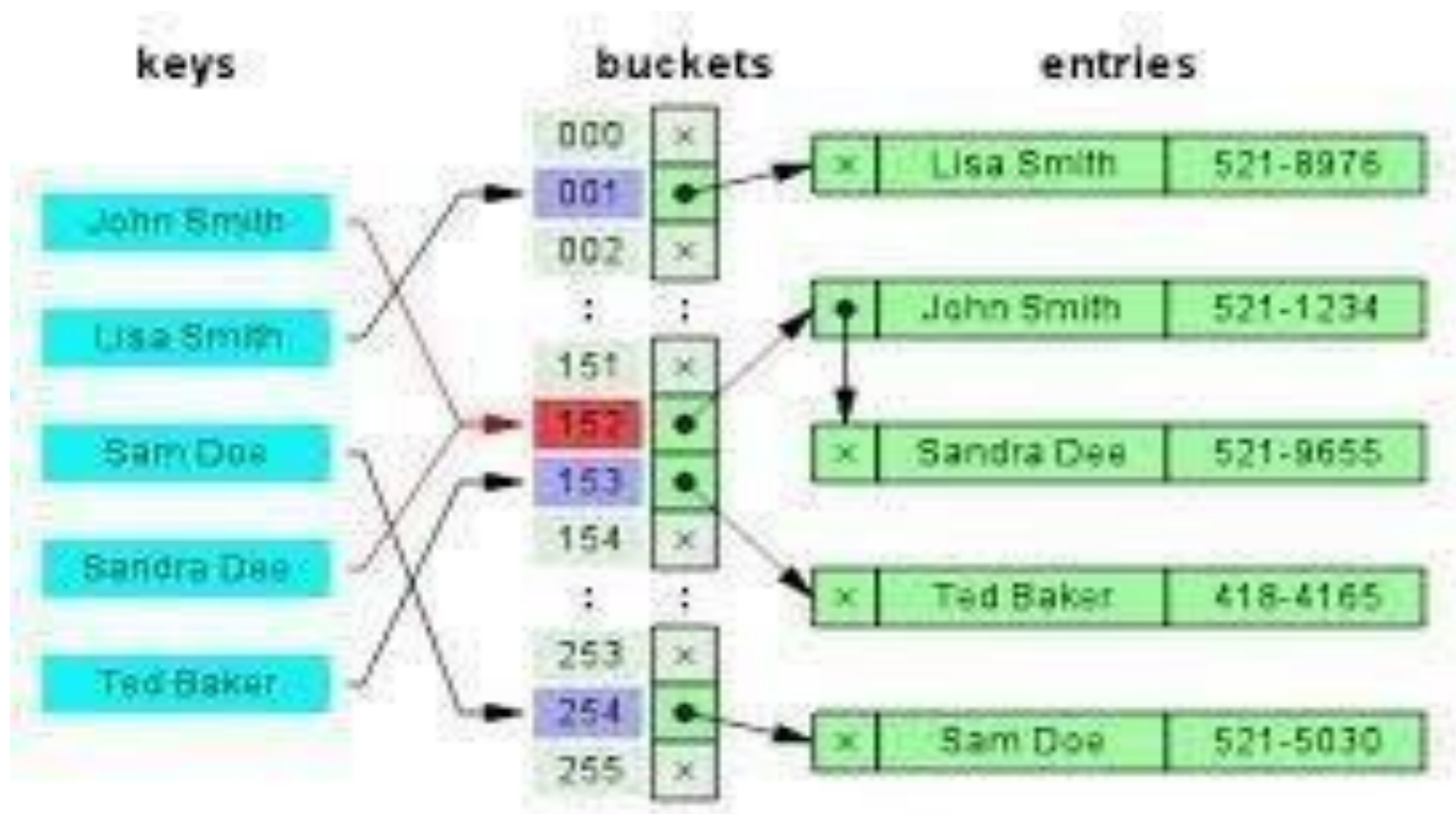

Closed Hashing (Open Addressing)

- In this technique a hash table with pre-identified size is considered. All items are stored in the hash table itself. In addition to the data, each hash bucket also maintains the three states: **EMPTY**, **OCCUPIED**, **DELETED**. While inserting, if a collision occurs, alternative cells are tried until an empty bucket is found. For which one of the following technique is adopted.
- **Liner Probing**
- **Quadratic probing**
- **Double hashing**

A Comparative Analysis of Closed Hashing vs Open Hashing

Open Addressing	Closed Addressing
All elements would be stored in the Hash table itself. No additional data structure is needed.	Additional Data structure needs to be used to accommodate collision data.
In cases of collisions, a unique hash key must be obtained.	Simple and effective approach to collision resolution. Key may or may not be unique.
Determining size of the hash table, adequate enough for storing all the data is difficult.	Performance deterioration of closed addressing much slower as compared to Open addressing.
State needs be maintained for the data (additional work)	No state data needs to be maintained (easier to maintain)
Uses space efficiently	Expensive on space

- A hash function maps a variable length input string to fixed length output string -- its hash value, or hash for short. If the input is longer than the output, then some inputs must map to the same output -- a hash collision.
- Comparing the hash values for two inputs can give us one of two answers: the inputs are definitely not the same, or there is a possibility that they are the same. Hashing as we know it is used for performance improvement, error checking, and authentication.
- In error checking, hashes (checksums, message digests, etc.) are used to detect errors caused by either hardware or software. Examples are TCP checksums, ECC memory, and MD5 checksums on downloaded files.

Applications of Hashing

- **Construct a *message authentication code* (MAC)**
- **Digital signature**
- **Make commitments, but reveal message later**
- **Timestamping**
- **Key updating: key is hashed at specific intervals resulting in new key**

THANK YOU