



**INSTITUTE OF AERONAUTICAL ENGINEERING**  
**(Autonomous)**  
Dundigal, Hyderabad -500 043

**ELECTRONICS & COMMUNICATION ENGINEERING**

**COURSE LECTURE NOTES**

<b>Course Name</b>	<b>ELECTRONIC MEASUREMENT AND INSTRUMENTATION</b>
<b>Course Code</b>	AEC014
<b>Programme</b>	B.Tech
<b>Semester</b>	VI
<b>Course Coordinator</b>	Ms. P.Annapurna, Assistant Professor, ECE
<b>Course Faculty</b>	Mr. Mohd.Khadir, Assistant Professor, ECE Ms. M.Saritha, Assistant Professor, ECE Ms. M.Lavanya, Assistant Professor, ECE
<b>Lecture Numbers</b>	1-63
<b>Topic Covered</b>	All

**COURSE OBJECTIVES:**

The course should enable the students to:

I	Acquire a sound understanding theory and performance characteristics of instruments and errors in measurement and apply to DC voltmeters, ammeters, ohmmeters.
II	Provide concepts and operation of different signal generators and wave form analyzers.
III	Compare and contrast different types of oscilloscopes.
IV	Select different types of D.C and A.C bridges for measurement of passive components and physical parameters.

**COURSE LEARNING OUTCOMES:**

Students, who complete the course, will have demonstrated the ability to do the following:

<b>S. NO</b>	<b>DESCRIPTION</b>
AEC014.01	Analyze Block schematics of measuring systems, performance characteristics like accuracy, precision, resolution and the types of errors.
AEC014.02	Understand the analog measuring instruments its working of analog measuring instruments D' Arsonval movement.
AEC014.03	Discuss various types measuring range meters like DC and AC voltmeters ammeters.
AEC014.04	Understand of basic building of Cathode ray oscilloscopes and cathode ray tubes its specifications and applications.
AEC014.05	Illustrate the various types of special purpose oscilloscopes and discuss Lissajous figures, frequency measurement, phase measurement, CRO probes.
AEC014.06	Understand working principle of signal generators like AF and RF signal generators and Discuss the types of function generators.
AEC014.07	Understand the function of various types of signal analyzers and discuss the type like AF, HF wave analyzers.

AEC014.08	Understand the various wave analyzers heterodyne wave analyzers, harmonic distortion, spectrum analyzers, power analyzers.
AEC014.09	Discuss various measurements using DC bridges for Wheat stone bridge, Kelvin bridge.
AEC014.10	Discuss various measurements using AC bridges, Maxwell, Hay, Schering, Wien, Anderson bridges, wagner & ground connection.
AEC014.11	Understand transducers and its classifications and discuss strain gauges, force and displacement transducers, resistance thermometers, hotwire anemometers, LVDT, thermocouples, synchros
AEC014.12	Discuss the types of transducers Piezoelectric transducers, variable capacitance transducers; Magneto strictive transducers
AEC014.13	Determine measurement of physical parameters Flow measurement, displacement meters, liquid level measurement, measurement of humidity and moisture
AEC014.14	Illustrate the following: active and passive, primary and secondary transducers
AEC014.15	Illustrate the measurement of physical parameters of transducer like velocity, force, pressure, high pressure, vacuum level, temperature measurements
AEC014.16	Apply the concept of Electronic measurement and instrumentation to understand and analyze the real time applications.
AEC014.17	Acquire the knowledge and develop capability to succeed national and international level competitive examinations.

### **UNIT – I**

#### **INTRODUCTION TO MEASURING INSTRUMENTS:**

Block schematics of measuring systems, performance characteristics, Static characteristics: Accuracy, resolution, precision, gauss error, types of errors, Dynamic characteristics : Repeatability, reproducibility, fidelity, lag; Analog measuring instruments: D' Arsonval movement, DC voltmeters and ammeter, AC voltmeters and current meters, ohmmeters, multimeters, meter protection, extension of range, digital voltmeters: Ramp type, staircase, dual slope integrating type, successive approximation type, specifications of instruments.

### **UNIT – II**

#### **OSCILLOSCOPE:**

Oscilloscopes: CRT, block schematic of CRO, time base circuits, delay lines, high frequency CRO considerations, applications, specifications, special purpose oscilloscopes: Dual trace, dual beam CROs, sampling oscilloscopes, storage oscilloscopes, digital storage CROs, Lissajous figures, frequency measurement, phase measurement, CRO probes.

### **UNIT – III**

#### **SIGNAL GENERATOR AND SIGNAL ANALYZERS:**

Signal Generators: AF and RF signal generators, sine and square wave generators, function generators: arbitrary waveform generator, sweep frequency generators, video signal generators, specifications. Signal Analyzers: AF, HF wave analyzers, heterodyne wave analyzers, harmonic distortion, spectrum analyzers, power analyzers

### **UNIT – IV**

#### **AC AND DC BRIDGES:**

Measurements using DC and AC bridges: Wheat stone bridge, Kelvin bridge, AC bridges, Maxwell, Hay, Schering, Wien, Anderson bridges, wagner & ground connection.

### **UNIT – V**

#### **TRANSDUCERS:**

Transducers: Classification, strain gauges, force and displacement, transducers, resistance thermometers, hotwire anemometers, LVDT, thermocouples, synchros; Piezoelectric transducers, variable capacitance transducers; Magneto strictive transducers, measurement of physical parameters: Flow measurement, displacement meters, liquid level measurement, measurement of humidity and moisture, velocity, force, pressure, high pressure, vacuum level, temperature measurements.

## UNIT-I

### BLOCK SCHEMATIC OF MEASURING SYSTEMS

The Basic Measurement system is a set of different blocks which can be used to measure any quantity or to specify anything which can be measured. The block diagram of a simple measurement system is given above. A Basic Measurement system consists of following main blocks:

#### ANALOG INSTRUMENTATION SYSTEM



- Transducer or Primary Sensing Element
- Signal Conditioner
- Output Device

**Transducer or Primary Sensing Element:** A Transducer is a device which converts one form of energy into some other form of energy. The input to the transducer or primary sensing element is any quantity that is it can be Electrical as well as Non-Electrical. Its main function is to convert one form of energy into some other useful form of energy. It is also known as 'Pickup Element'.

Mainly Transducers can be classified into two types on the basis of power supply required:

1. Active Transducers
2. Passive Transducers.

**Active Transducers:** Active transducers are those which does not requires external power supply for their operation. For example: Photo Voltage Cell, Piezo Electric Crystal, Generator etc.

**Passive Transducers:** Passive Transducers are those transducers which requires external power supply for their operation. For Example: Resistive, Inductive and Capacitive Transducers.

**Signal Conditioner:** Signal Conditioner is a very important part of any measurement system. Its role comes into play when the output of transducer or primary sensing element is very low. It is used to amplify or modify the incoming signal from transducer according to output requirement. We may either clip the signal, amplify the signal or can modify the signal in some other way according to our requirement. In other words Signal Conditioning is done to improve the quality of output of measurement system. The examples of signal conditioners are : Amplifier, A to D Converter (Analog to Digital Converter), Multiplexer, Modulator etc.

**Output Unit:** The output unit of a measurement system is consists of a measurement device or we can say it 'secondary transducer'. It is used to display or analyze the final output of the measurement system. The examples of Output unit can be any output device like CRO (Cathode Ray Oscilloscope) or XY recorder.

## **Performance Characteristics of Measurement SYSTEM:**

The performance characteristics of an instrument are mainly divided into two categories:

- i) Static characteristics
- ii) Dynamic characteristics

### **STATIC CHARACTERISTICS:**

The set of criteria defined for the instruments, which are used to measure the quantities which are slowly varying with time or mostly constant, i.e., do not vary with time, is called '**static characteristics**'.

#### **The various static characteristics are:**

- i) Accuracy
- ii) Precision
- iii) Sensitivity
- iv) Linearity
- v) Reproducibility
- vi) Repeatability
- vii) Resolution
- viii) Threshold
- ix) Drift
- x) Stability
- xi) Tolerance
- xii) Range or span

#### **Accuracy:**

It is the degree of closeness with which the reading approaches the true value of the quantity to be measured. The accuracy can be expressed in following ways:

##### **a) Point accuracy:**

Such accuracy is specified at only one particular point of scale.

It does not give any information about the accuracy at any other Point on the scale.

##### **b) Accuracy as percentage of scale span:**

When an instrument has uniform scale, its accuracy may be expressed in terms of scale range.

##### **c) Accuracy as percentage of true value:**

The best way to conceive the idea of accuracy is to specify it in terms of the true value of the quantity being measured. Precision: It is the measure of reproducibility i.e., given a fixed value of a quantity, precision is a measure of the degree of agreement within a group of

measurements. The precision is composed of two characteristics:

**a) Conformity:**

Consider a resistor having true value as 2385692, which is being measured by an ohmmeter. But the reader can read consistently, a value as 2.4 M due to the no availability of proper scale. The error created due to the limitation of the scale reading is a precision error.

**b) Number of significant figures:**

The precision of the measurement is obtained from the number of significant figures, in which the reading is expressed. The significant figures convey the actual information about the magnitude & the measurement precision of the quantity. The precision can be mathematically expressed as:

$$P=1-|[X_n-X_n(\text{bar})/X_n(\text{bar})]$$

Where, P = precision

$X_n$  = Value of nth measurement

$X_n(\text{bar})$  = Average value the set of measurement values

**Sensitivity:**

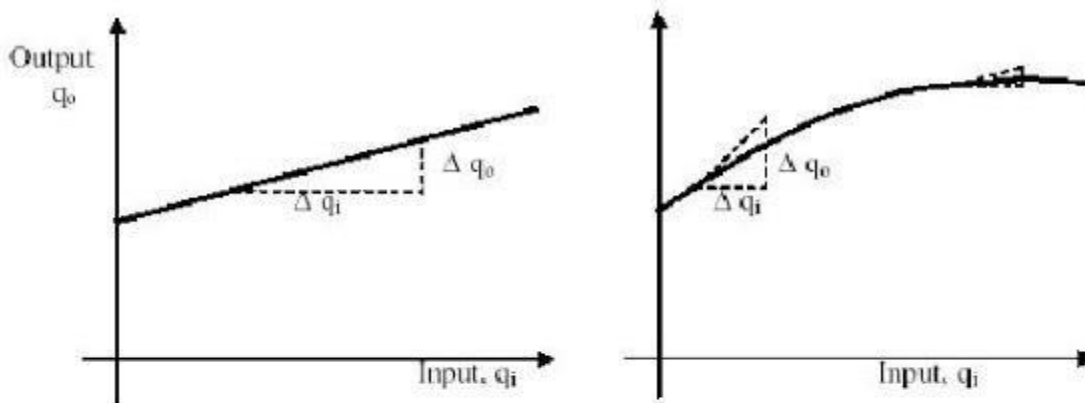

$$\text{Sensitivity} = \frac{\text{Infinitesimal change in output}}{\text{Infinitesimal change in input}}$$
$$= \frac{\Delta q_o}{\Delta q_i}$$

Thus, if the calibration curve is linear, as shown, the sensitivity of the instrument is the slope of the calibration curve. If the calibration curve is not linear as shown, then the sensitivity varies with the input. Inverse sensitivity or deflection factor is defined as the reciprocal of sensitivity. Inverse sensitivity or deflection factor =  $1/\text{sensitivity}$

**Reproducibility:**

It is the degree of closeness with which a given value may be repeatedly measured. It is specified in terms of scale readings over a given period of time.

**Repeatability:**

It is defined as the variation of scale reading & random in nature Drift:  
Drift may be classified into three categories:

**a) zero drift:**

If the whole calibration gradually shifts due to slippage, permanent set, or due to undue warming up of electronic tube circuits, zero drift sets in.

**b) Span drift or sensitivity drift:**

If there is proportional change in the indication all along the upward scale, the drifts is called span drift or sensitivity drift.

**c) Zonal drift:**

In case the drift occurs only a portion of span of an instrument, it is called zonal drift.

**Resolution:**

If the input is slowly increased from some arbitrary input value, it will again be found that output does not change at all until a certain increment is exceeded. This increment is called resolution.

**Threshold:**

If the instrument input is increased very gradually from zero there will be some minimum value below which no output change can be detected. This minimum value defines the threshold of the instrument.

**Stability:**

It is the ability of an instrument to retain its performance throughout its specified operating life.

**Tolerance:**

The maximum allowable error in the measurement is specified in terms of some value which is called tolerance.

**Range or span:**

The minimum & maximum values of a quantity for which an instrument is designed to measure is called its range or span.

**Dynamic characteristics:**

The set of criteria defined for the instruments, which are changes rapidly with time, is called ‘dynamic characteristics’.

**The various static characteristics are:**

- i) Speed of response
- ii) Measuring lag
  
- iii) Fidelity
- iv) Dynamic error

**Speed of response:**

It is defined as the rapidity with which a measurement system responds to changes in the measured quantity.

**Measuring lag:**

It is the retardation or delay in the response of a measurement system to changes in the measured quantity. The measuring lags are of two types:

**a) Retardation type:**

In this case the response of the measurement system begins immediately after the change in measured quantity has occurred.

**b) Time delay lag:**

In this case the response of the measurement system begins after a dead time after the application of the input. Fidelity: It is defined as the degree to which a measurement system indicates changes in the measured quantity without dynamic error.

**Dynamic error:**

It is the difference between the true value of the quantity changing with time & the value indicated by the measurement system if no static error is assumed. It is also called measurement error.

**DC VOLTMETER:**

**Basic Voltmeter:**

To use the basic meter as a dc voltmeter, it is necessary to know the amount of current required to deflect the basic meter to full scale known as full scale deflection current ( $I_{fsd}$ ).

Sensitivity is given as

$$\text{For } I_{fsd} = 50\text{microamp, } S = 1/I_{fsd} = 1/50 * 10^{-6} = 20\text{Kiloohms/Volt}$$

Hence a 0-1mAmp would have a sensitivity of  $1\text{V}/1\text{mAmp} = 1\text{Kohm}/\text{V}$ .

The sensitivity is based on the fact that the full-scale current of 50 micro amperes results whenever 20000 ohms of resistance is present in the meter circuit for each voltage applied.

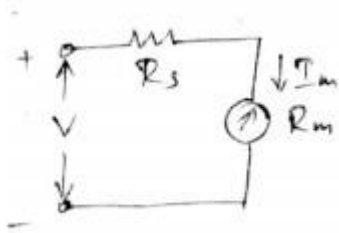

A basic D'Arsonval movement can be converted into a dc voltmeter by adding a series resistor known as multiplier. The multiplier limits the current through the movement so that the current does not exceed the full-scale deflection value.

$I_m$ =full scale deflection current  $I_{fsd}$

$R_m$ =internal resistance of the movement

$R_s$ =multiplier resistance

$V$ =full range voltage of the instrument

From the circuit,

$$V = I_m R_s + I_m R_m$$

$$R_s = (V - I_m R_m) / I_m = (V / I_m) - R_m = (S * V) - R_m$$

The multiplier limits the current through the meter so as not to exceed the value of the full scale deflection  $I_{fsd}$ .

### Problems:

1. A basic D'Arsonval movement with a full-scale deflection 50microAmp and internal resistance 500 ohms is used as a voltmeter. Find the multiplier resistance needed to measure a voltmeter range of 0-10V.

**Sol:**  $R_s = (V / I_m) - R_m$   
 $= (10 / (50 * 10^{-6})) - 500$   
 $= 199.5 \text{Kiloohms}$

2. Calculate the value of the multiplier resistance on 50v range of a DC voltmeter that uses 500microamp meter movement with an internal resistance 1kiloohm.

**Sol:** sensitivity of 500microamp meter  $S = 1 / I_m = 1 / (500 * 10^{-6}) = 2 \text{Kohms/V}$

Multiplier resistance  $R_s = (S * V) - R_m = (2 * 50) - 1 \text{Kiloohms} = 99 \text{Kiloohms}$ .



## MULTIRANGE VOLTMETER:

To get a multirange ammeter, a number of shunts are connected across the meter with a multi position switch, similarly a dc voltmeter can be connected into a multimeter voltmeter by connecting number of resistors along with a range switch to provide a greater number of ranges.

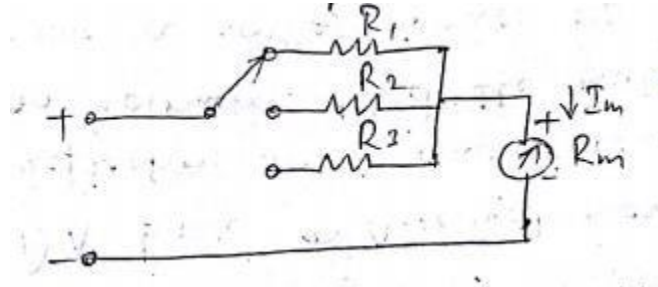
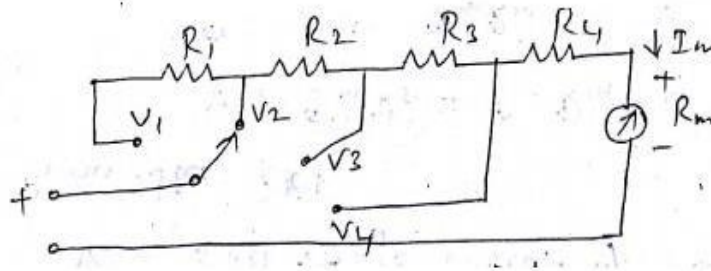

Figure above shows a multirange voltmeter using a 3 positions switch and three multiplier resistances  $R_1$ ,  $R_2$  and  $R_3$  for voltage values  $v_1$ ,  $v_2$  and  $v_3$ .

## Modified multirange voltmeter:



Here the multiplier resistances are connected in series and the range selector selects the appropriate amount of resistance required in series with the meter.

This is advantageous compared to the previous circuit, as all resistance except the resistor  $R_4$  has to be specially manufactured.

## Problem:

1. A D' Arsonval movement with a full-scale deflection current of 50microamp and internal resistance 500ohm is to be connected into a multirange voltmeter. Find the value of the multiplier resistances for 0-20V, 0-50V.

## Sol:

$$I_m = 50\text{microamp } R_m = 500\text{ohm}$$

## For 0-20V

$$R_{s1} = (V/I_m) - R_m = (20/50 * 10^{-6}) - 500 = 399.5\text{Kohm}$$

### For 0-50V

$$R_{s2} = (V/I_m) - R_m = (50/50 \times 10^{-6}) - 500 = 999.5 \text{Kohm}$$

### Differential Voltmeter

The differential voltmeter technique, is one of the most common and accurate methods of measuring unknown voltages. In this technique, the voltmeter is used to indicate the difference between known and unknown voltages i.e., an unknown voltage is compared to a known voltage.

The basic circuit of a differential voltmeter is based on the potentiometric method; hence it is sometimes also called a potentiometric voltmeter.

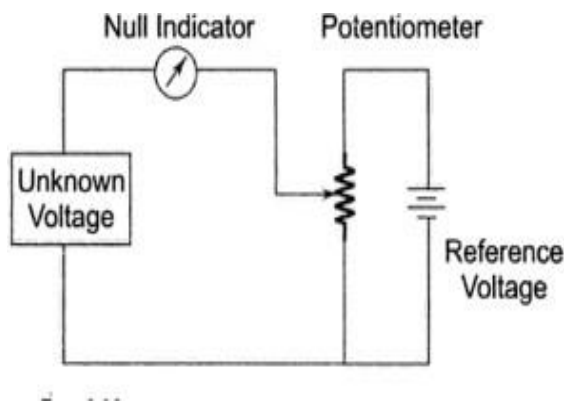

a) Basic differential voltmeter

In this method, the potentiometer is varied until the voltage across it equals the unknown voltage, which is indicated by the null indicator reading zero.

Under null conditions, the meter draws current from neither the reference source nor the unknown voltage source, and hence the differential voltmeter presents an infinite impedance to the unknown source. (The null meter serves as an indicator only.)

To detect small differences the meter movement must be sensitive, but it need not be calibrated, since only zero has to be indicated.

The reference source used is usually a 1 V dc standard source or a zener controlled precision supply. A high voltage reference supply is used for measuring high voltages.

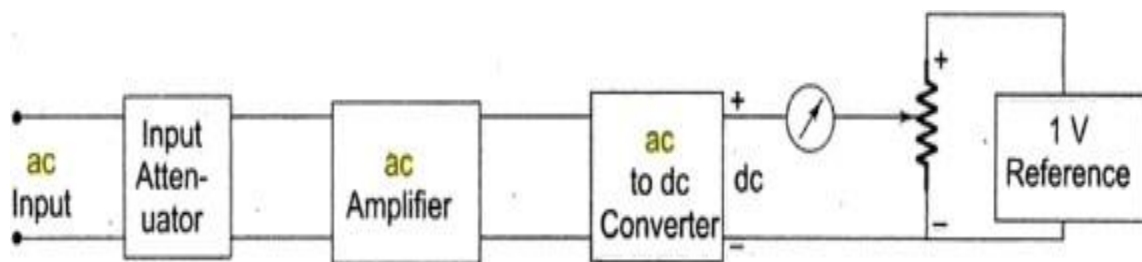

Block diagram of an ac differential voltmeter.

The usual practice, however, is to employ voltage dividers or attenuators across an unknown source to reduce the voltage. The input voltage divider has a relatively low input impedance, especially for unknown voltages much higher than the reference standard. The attenuation will have a loading effect and the input resistance of voltmeter is not infinity when an attenuator is used.

In order to measure ac voltages, the ac voltage must be converted into dc by incorporating a precision rectifier circuit.

### Solid State Voltmeter :

The circuit of an electronic voltmeter using an IC opamp 741C. This is directly coupled to very high gain amplifier. The gain of the opamp can be adjusted to any suitable lower value by providing appropriate resistance between its output terminal. Pin No. 6, and inverting input, Pin No. 2, to provide a negative feedback.

The ratio  $R_2/R_1$  determines the gain, i.e. 101 in this case, provided by the opamp. The  $0.1 \mu\text{F}$  capacitor across the  $100 \text{ k}$  resistance  $R_2$  is for stability under stray pick – ups. Terminals 1 and 5 are called offset null terminals. A  $10 \text{ k}\Omega$  potentiometer is connected between these two offset null terminals with its center tap connected to a  $5\text{V}$  supply. This potentiometer is called zero set and is used for adjusting zero output for zero input conditions.

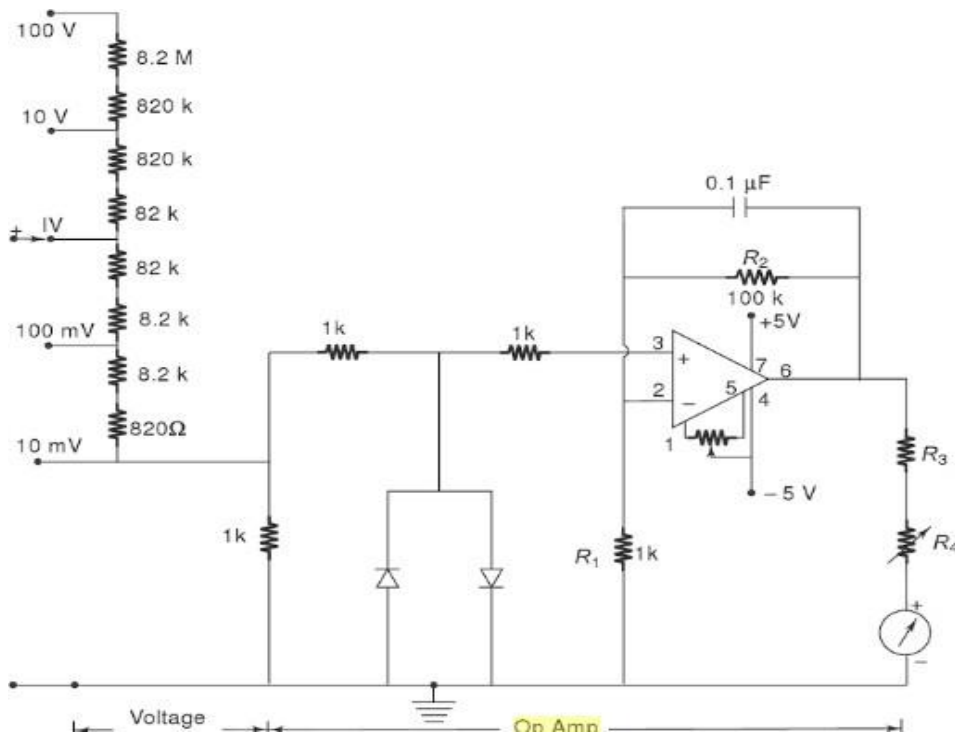

Solid State mV voltmeter using an Op Amp

The two diodes used are for IC protection. Under normal conditions, they are non-conducting, as the maximum voltage across them is  $10 \text{ mV}$ . If an excessive voltage, say more than  $100 \text{ mV}$  appears across them, then depending upon the polarity of the voltage, one of the diodes conducts and protects the IC. A

$\mu\text{A}$  scale of 50 – 1000  $\mu\text{A}$  full scale deflection can be used as an indicator.  $R_4$  is adjusted to get maximum full scale deflection.

### AC Voltmeter:

In electronic ac voltmeters input signal is firstly rectified and then supplied to the dc amplifier, as shown in figure. Sometimes signal is firstly amplified by AC amplifier and then rectified before supplying it to dc meter, as shown in figure. In the former case the advantage is of economical amplifiers and the arrangement is usually used in low priced voltmeters.



*Block Diagram of AC Voltmeter*



*Block Diagram of AC Voltmeter* [www.circuitstoday.com](http://www.circuitstoday.com)

AC Voltmeters are broadly classified into two categories:

- 1) Average Reading AC Voltmeter
- 2) Peak Reading AC Voltmeter

### Average Reading AC Voltmeter:

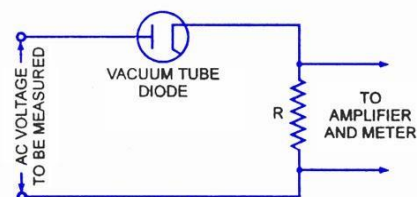

*Average Reading AC Voltmeter Using Vacuum Tube Diode*

Normally ac voltmeters are average responding type and the meter is calibrated in terms of the rms values for a sine wave. Since most of the voltage measurements involve sinusoidal waveform so this method of measuring rms value of ac voltages works satisfactorily and is less expensive than true rms responding voltmeters. However, in case of measurement of non-sinusoidal waveform voltage, this meter will give high or low reading depending on the form factor of the waveform of the voltage to be measured.

The circuit diagram for an average reading voltmeter using a vacuum tube diode is shown in figure. The arrangement requires a vacuum tube diode, a high resistance (of the order of  $10^5 \Omega$ ) R and PMMC instrument, all connected in series, as shown in fig. Resistance R is used to limit the current and make the plate voltage-current characteristics linear. The linear plate characteristics are essential in order to make the current directly proportional to voltage. Also because of high series resistance R, plate resistance of vacuum tube diode becomes negligible and therefore variations in plate resistance do not cause non-linearity in voltage-current characteristics. In this way we get the scale of PMMC instrument uniform and independent of variations of tube plate resistance. Voltage across the high resistance is fed to dc amplifier and output of the amplifier is fed to PMMC instrument. Circuit diagram of an average reading ac voltmeter using semi-conductor diode is shown in figure.

### Peak Reading AC Voltmeter:

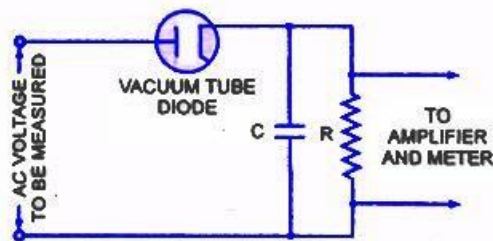

*Peak Reading AC Voltmeter Using Vacuum Tube Diode*

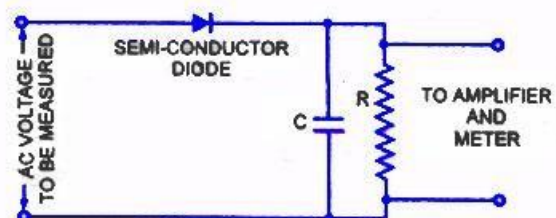

*Peak Reading AC Voltmeter Using Semi-conductor Diode*

In this type of voltmeters capacitor C is charged to the peak value of the applied voltage and capacitor is discharged through the high resistance R between two peaks of the wave which results in a small fall in capacitor voltage. But this voltage is again built up during next peak of the wave, as shown in figure. So, voltage across capacitor C and resistance R remains almost constant and equal to the peak value of the applied voltage. Either the average voltage across R or the average current through R, can be used to indicate the peak value of applied voltage. In case the vacuum tube diode (or semi-conductor diode), series resistance R shunted by capacitance C and PMMC are connected in series across the source of unknown voltage, the current through the PMMC will indicate the peak value of applied voltage.

In case, the circuit shown in figure making use of rectifying diode, series resistance R, dc amplifier and PMMC is employed, the average voltage across R will indicate the peak value of applied voltage. This alternative is preferred, as explained earlier, the power consumption can be reduced by making series resistance R high. By making series resistance R high a less sensitive type of PMMC instrument can also be used. The high value input resistance also gives more linear relationship between peak applied voltage and the instrument indication.

## DC AMMETERS

Ammeter means Ampere-meter which measures ampere value. Ampere is the unit of current so an ammeter is a meter or an instrument which measures current.

### Classification or Types of Ammeter

Depending on the constructing principle, there are many types of ammeter we get, they are mainly –

- Permanent Magnet Moving Coil(PMMC) ammeter.
- Moving Iron(MI) Ammeter.
- Electrodynamometer type Ammeter.
- Rectifier type Ammeter.

Depending on this type of measurement we do, we have-

1. DC Ammeter.
2. AC Ammeter.

DC Ammeter are mainly PMMC instruments, MI can measure both AC and DC currents, also Electrodynamometer type thermal instrument can measure DC and AC, induction meters are not generally used for ammeter construction due to their higher cost, inaccuracy in measurement.

### PMMC Ammeter:

#### Principle PMMC Ammeter:

When current carrying conductor placed in a magnetic field, a mechanical force acts on the conductor, if it is attached to a moving system, with the coil movement, the pointer moves over the scale

**Explanation:** As the name suggests it has permanent magnets which are employed in this kind of measuring instruments. It is particularly suited for DC measurement because here deflection is proportional to the current and hence if current direction is reversed, deflection of the pointer will also be reversed so it is used only for DC measurement. This type of instrument is called D Arsonval type instrument. It has major advantage of having linear scale, low power consumption, high accuracy. Major disadvantage of being measured only DC quantity, higher cost etc. Deflecting torque,

$$T = BiNlbNm$$

Where, B = Flux density in Wb/m<sup>2</sup>. i = Current flowing through the coil in Amp. l = Length of the coil in m. b = Breadth of the coil in m. N = No of turns in the coil.

#### Extension of Range in a PMMC Ammeter:

Now it looks quite extraordinary that we can extend the range of measurement in this type of instrument. Many of us will think that we must buy a new ammeter to measure higher amount of current and also

many of us may think we have to change the constructional TYPE Nature so that we can measure higher currents, but there is nothing like that, we just have to connect a shuntresistance in parallel and the range of that instrument can be extended, this is a simple solution provided by the instrument.

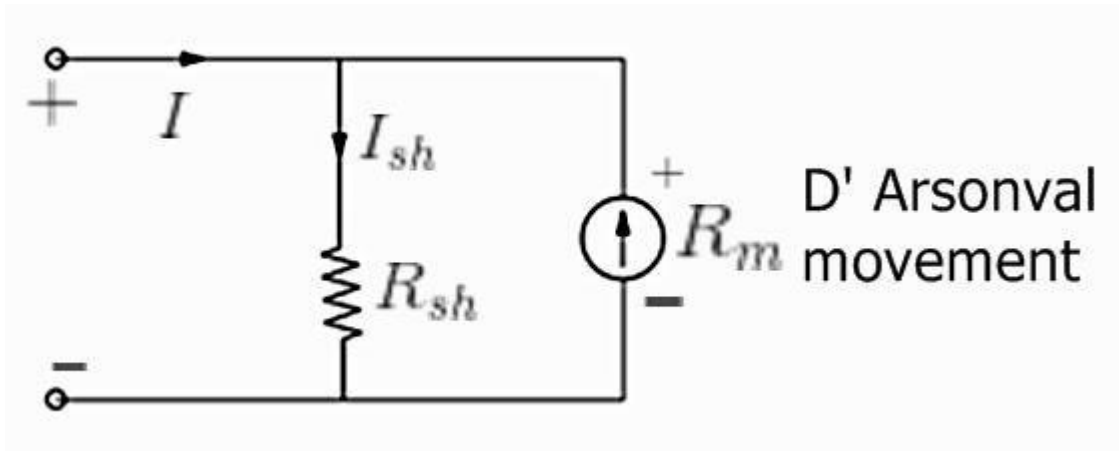

In the figure  $I$  = total current flowing in the circuit in Amp.  $I_{sh}$  is the current through the shunt resistor

in Amp.  $R_m$  is the ammeter resistance in Ohm.

$$\text{Then, } R_{sh} = \frac{R_m}{\frac{I}{I - I_{sh}} - 1}$$

### THERMO COUPLED TYPE RF AMMETERS

Basically thermocouple consists of two different metals which are placed in contact with each

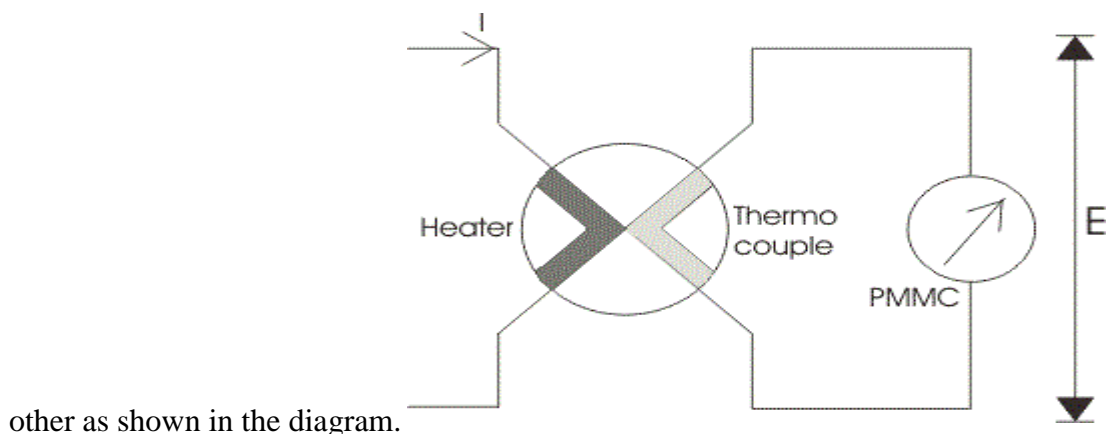

other as shown in the diagram.

First part is called the heater element because when the current will flow through this, a heat is produced and thus the temperature will increase at the junction. At this junction an emf is produced which is



approximately proportional to the temperature difference of hot and cold junctions. The emf produced is a DC voltage which is directly proportional to root mean square value of electric current. A permanent magnet moving coil instrument is connected with the second part to read the current passing through the heater. One question must be arise in our mind that why we have used only a permanent magnet coil instrument? Answer to this question is very easy it is because PMMC instrument has greater accuracy and sensitivity towards the measurement of DC value. The thermocouple type instruments employ thermocouple in their construction. Thermocouple type instruments can be used for both ac and DC applications. Also, thermocouple type of instruments has greater accuracy in measuring the current and voltages at very high frequency accurately.

Let us consider temperature of the heater element be  $T_a$  and the temperature of cold metal be  $T_b$ . Now it is found that the generated emf at the junction is related to temperature difference as:

$$e = a(T_a - T_b) + b(T_a - T_b)^2$$

Where a and b are constant whose values completely depends upon the type of metal we are using. The above equation represents parabolic function. The approximated value of a is from 40 to 50 micro volts or more per degree Celsius rise in temperature and value of constant b is very small and can be neglected if the air gap field of permanent magnet moving coil is uniform. Thus we can approximate the above temperature emf relation as  $e = a(T_a - T_b)$ , here we have assume  $b = 0$ . The current flowing through the heater coil produces heat as  $I^2R$  where I is the root mean square value of current, if we assume the temperature of cold junction is maintained at room temperature then the rise in the temperature of the hot junction will be equal to temperature rise at the junction.

Hence we can write  $(T_a - T_b)$  is directly proportional to  $I^2R$  or we can say  $(T_a - T_b) = kI^2R$ . Now the deflection angle  $x$  in moving coil instrument is equal to;  $x = Ke$  or  $x = K[a(T_a - T_b)]$  hence we can write  $k.K.a.I^2R = k_1I^2$ , where  $k_1$  is some constant. From the above equation we see that the instrument shows the square law response.

### **Construction of Thermocouple Type Instrument:**

The thermocouple type of instruments consists of two major parts which are written below:

- (a) Thermo electric elements: The thermocouple type of instruments consists of thermo electric elements which can be of four types:
- (b)

1. **Contact Type:** It has a separate heater which is shown in the diagram.



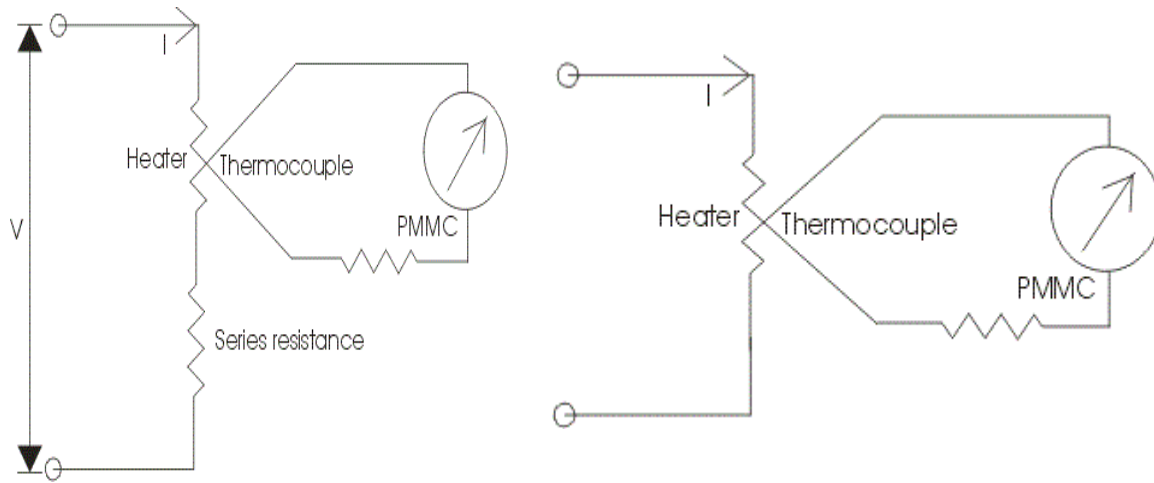

The action of thermocouple type instruments can be explained briefly as,

- At the junction the electrical energy is being converted to thermal energy in the heater element. A portion of the heat is transferred to the hot junction while most of the heat energy is dissipated away.
  - The heat energy which is transferred to hot junction is again converted to electrical due to Seebeck effect. Only a portion of electrical energy is converted into mechanical energy which is used to produce a deflecting torque. The overall efficiency of the system is low thus the instrument consumes high power. So there is a requirement of highly accurate and sensitive DC instrument.
2. **Non-Contact Type:** In non-contact type there is insulation between the heating element and the thermocouple i.e. there no direct contact between two. Due to this these instruments are not much sensitive as compared contact type.
  3. **Vacuum Thermo-elements:** These types of instruments are mostly employed for the measurement of electric current at very high frequency of the order of 100 Megahertz or more as these instruments retain their accuracy even at such high frequency.

4. **Bridge Type:** These bridges are manufactured on the ac ratings usually from 100 milli amperes to 1 amperes. In this two thermocouple are connected to form a bridge which is shown in the figure

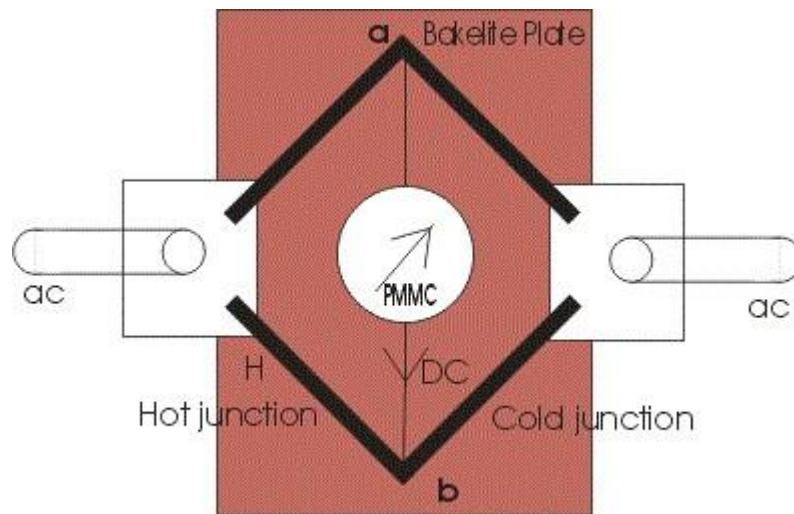

given below:

There is no requirement of heating element, the electric current which directly passing through the thermocouple raises the temperature which is directly proportional to the  $I^2R$  losses. The bridge works on balanced condition at which there will be no current in the arm ab. The connected meter will show the potential difference between the junctions a and b.

### Ohmmeters:

The ohmmeter is a device used for measurement of resistance value. These instruments have a low degree of accuracy. There is a wide field of application for this instrument in determining the approximate value of resistance. Micro Ohmmeter, Mega Ohmmeter and Milli Ohmmeters are used to measure resistance in different applications of electrical testing. A Micro Ohmmeter is used to measure extremely low resistances with high accuracy at particular test currents and is used for bonding contact applications. Micro Ohmmeter fluke is a small portable device, which is used to measure voltage, current and test diodes. This meter has multi selectors to select the desired function, and it automatically ranges to select most measurements. Mega Ohmmeter is used to measure large resistance values. Milli Ohmmeter is used to measure low resistance at high accuracy confirming the value of any electrical circuit.

Ohmmeters are classified into two types.

1. Series Ohmmeter
2. Shunt Ohmmeter

## Series Ohmmeter:

Series Ohmmeter consists of basic d'Arsonval movement connected in parallel with a shunting resistor  $R_2$ . This parallel circuit is in series with resistance  $R_1$  and a battery of emf  $E$ . the series circuit is connected to the terminals A and B of unknown resistor  $R_x$ .

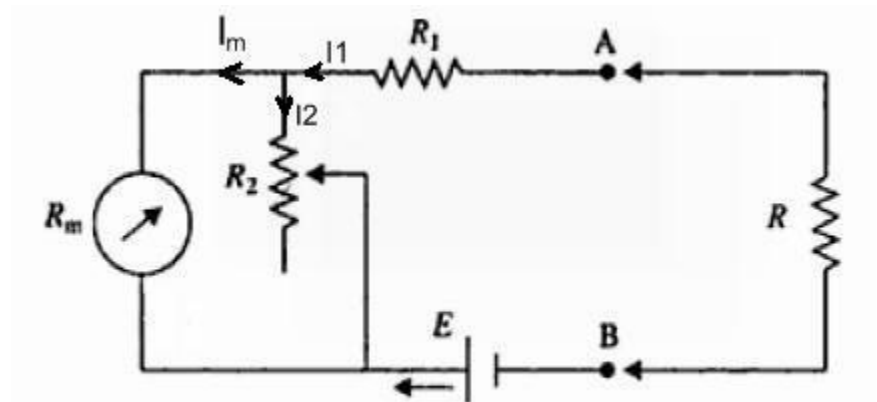

Basic series type ohmmeter.

For the figure,

- $R_1$  = current limiting resistor,
- $R_2$  = zero adjusting resistor,
- $E$  = emf of internal battery,
- $R_m$  = internal resistance of D'Arsonval movement

When the unknown resistance  $R_x = 0$  (terminals A and B shorted) maximum current flows through the meter. Under this condition resistor  $R_2$  is adjusted until the basic movement meter indicates full scale current  $I_{fs}$ . The full scale current position of the pointer is marked  $-0\Omega$  on the scale.

Similarly, when  $R_x$  is removed from circuit  $R_x = \infty$  (that is when terminal A and B are open), the current in the meter drops to the zero and the movement indicates zero current which is the marked  $-\infty\Omega$ . Thus, the meter will read infinite resistance at the zero-current position and zero resistance at full scale current position. Since zero resistance is indicated when current in the meter is the maximum and hence the pointer goes to the top mark.

When the unknown resistance is inserted at terminal A, B the current through the meter is reduced and hence pointer drops lower on the scale. Therefore, the meter has  $-0\Omega$  at extreme right and  $-\infty\Omega$  at the extreme left.

Intermediate scale marking may be placed on the scale by different known values of the resistance  $R_x$  to the instrument.

A convenient quantity to use in the design of the series ohmmeter is the value of the  $R_x$  which causes the half scale deflection of the meter. At this position, the resistance across terminals A and B is defined as the half scale position resistance  $R_h$ .

The design can be approached by recognizing the fact that when  $R_h$  is connected across A and B the meter current reduces to one half of its full-scale value or with  $R_x = R_h$ ,  $I_m = 0.5 I_{fs}$ .

where  $I_m$  = current through the meter

$I_{fs}$  = current through the meter for full scale deflection.

This clearly means that  $R_h$  is equal to the internal resistance of the ohmmeter looking into terminals A and B.

### Shunt Ohmmeter:

In the shunt ohmmeter, the resistance to be measured shunts (is in parallel with) the meter movement of the ohmmeter.

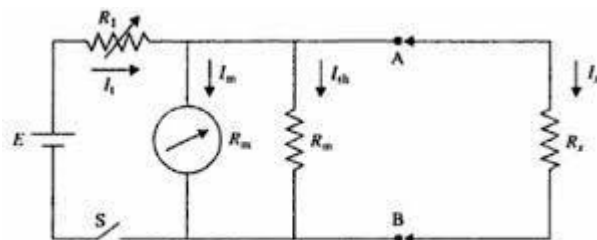
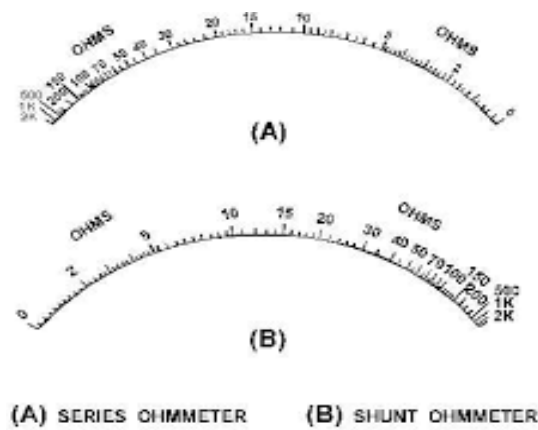

Figure3: Basic shunt-type ohmmeter

The basic circuit of the shunt-type ohmmeter where movement mechanism is connected parallel to the unknown resistance. In this circuit it is necessary to use a switch, otherwise current will always flow in the movement mechanism. Resistor  $R_{sh}$  is used to bypass excess current. Let the switch be closed. When  $R_x = 0$  (short circuit), the pointer reads zero because full current flows through  $R_x$  and no current flows through the meter and  $R_{sh}$ . Therefore, zero current reading is marked 0 ohms. When  $R_x = \infty$  (open circuit), no current flows through  $R_x$ . Resistor  $R_1$  is adjusted so that full-scale current flows through the meter. Therefore, maximum current reading is marked  $\infty$  ohms.

The most obvious way to tell the difference between the series and shunt ohmmeters is by the scale of the meter.



### Applications:

An ohmmeter is useful for determining the approximate resistance of circuit components such as heater elements or machine field coils, measuring and sorting of resistors used in electronic circuits, checking of semiconductor diodes and for checking of continuity of circuit.

It is also useful in laboratories as an aid to a precision bridge, for it can help to know the approximate value of resistance which can save time in balancing the bridge.

## MULTIMETERS FOR VOLTAGE, CURRENT AND RESISTANCE MEASUREMENT

### Multimeter:

A multimeter consists of an ammeter, voltmeter and ohmmeter combined, with a function switch to connect the appropriate circuit to the D'Arsonval movement.

Salient features of multimeter are

1. The basic circuit of multimeter includes balanced bridge d.c. amplifier.
2. To limit the magnitude of the input signal, RANGE switch is provided. By properly adjusting input attenuator input signal can be limited.
3. It also includes rectifier section which converts a.c. input signal to the d.c. voltage.
4. It facilitates resistance measurement with the help of internal battery and additional circuitry.
5. The various parameters measurement is possible by selecting required function using FUNCTION switch.
6. The measurement of various parameters is indicated with the help of Indicating Meter.

### Multimeter for D.C. Voltage Measurement:

For getting different ranges of voltages, different series resistances are connected in series which can be put in the circuit with the range selector switch. We can get different ranges to measure the d.c. voltages by selecting the proper resistance in series with the basic meter.

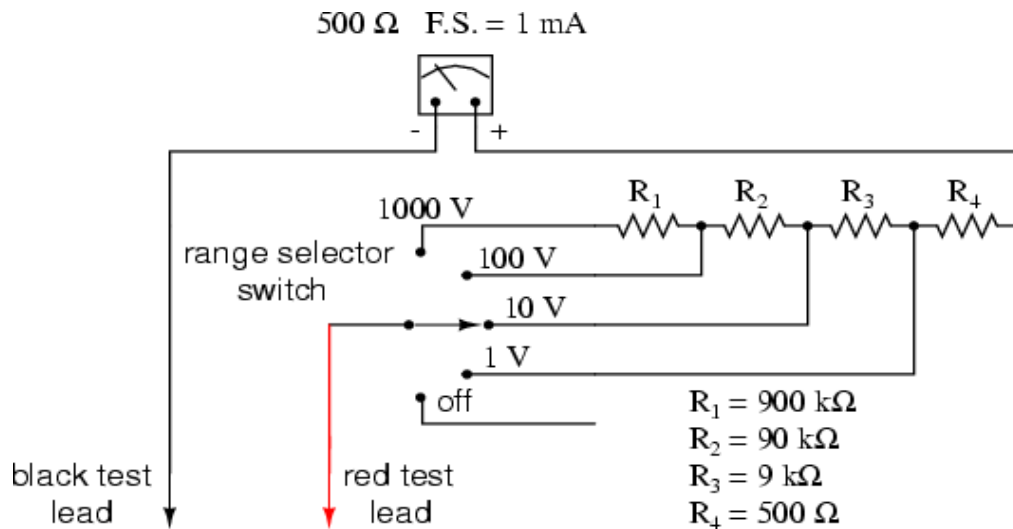

### Multimeter for Measurement of A.C Voltage:

The rectifier used in the circuit rectifies a.c. voltage into d.c. voltage for measurement of a.c. voltage before current passes through the meter. The other diode is used for the protection purpose.

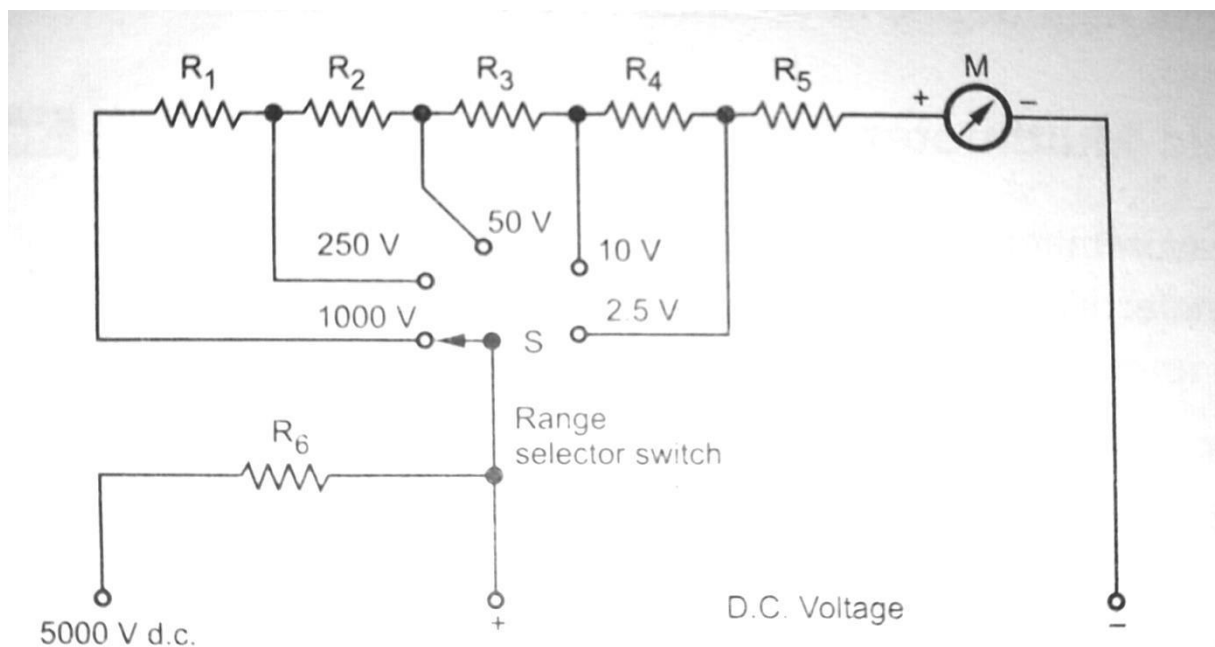

### Multimeter as an Ammeter:

To get different current ranges, different shunts are connected across the meter with the help of range selector switch. The working is same as that of PMMC ammeter. Range changing is accomplished by shunts in such a way that the current passing through the meter does not exceed the maximum rated value.

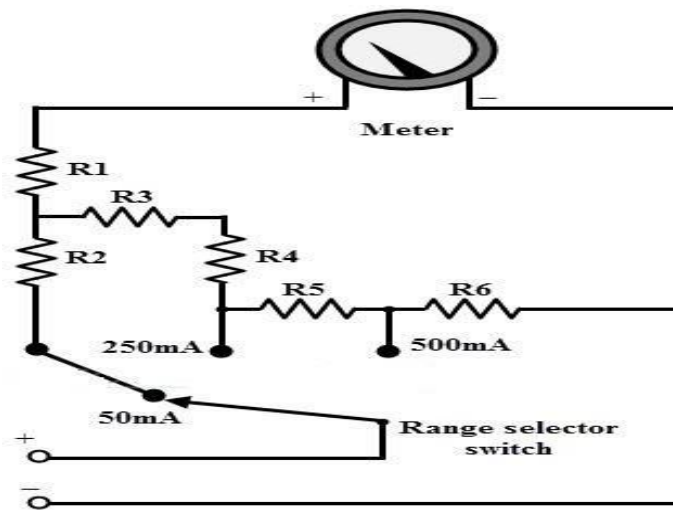

### Multimeter for Resistance Measurement:

Before any measurement is made, the instrument is short circuited and -zero adjustll control is varied until the meter reads zero resistance i.e. it shows full scale current. Now the circuit takes the form of a variation of the shunt type ohmmeter. Scale multiplications of 100 and 10,000 can also be used for measuring high resistances. Voltages are applied to the circuit with the help of battery.

The range of an ohmmeter can be changed by connecting the switch to suitable shunt resistance. By using different values of shunt resistance, different ranges can be obtained.

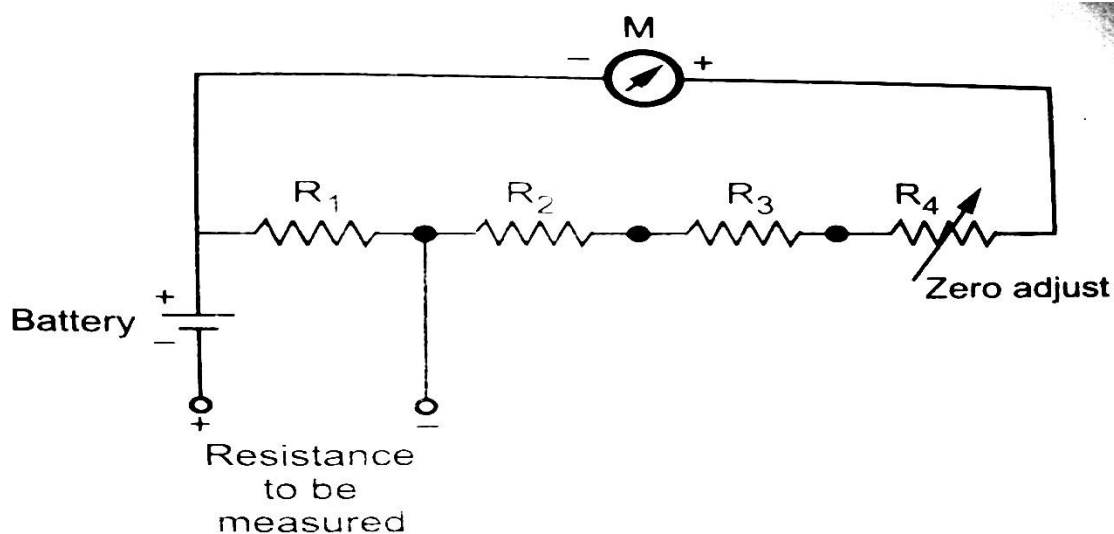

**Advantages:**

1. The input impedance is high.
2. The frequency range is high.
3. The circuit is simple.
4. The cost is less.
5. The construction is rugged.
6. It is less suffered from electric noise.

**Disadvantages**

1. The accuracy is less.
2. The resolution is poor.
3. It is difficult to interface the output with the external devices.
4. Not compact in size.
5. The reliability and repeatability are poor.

**DIGITAL INSTRUMENTS**

**Introduction:**

The digital voltmeters generally referred as DVM, convert the analog signals into digital and display the voltages to be measured as discrete numerals instead of pointer deflection, on the digital displays. Such voltmeters can be used to measure a.c. and d.c. voltages and also to measure the quantities like pressure, temperature, stress etc. using proper transducer and signal conditioning circuit.



The transducer converts the quantity into the proportional voltage signal and signal conditioning circuit brings the signal into the proper limits which can be easily measured by the digital voltmeter. The output voltage is displayed on the digital display on the front panel. Such a digital output reduces the human reading and interpolation errors and parallax errors. The DVMs have various features and the advantages, over the conventional analog voltmeters having pointer deflection on the continuous scale.

### **Performance parameters of digital voltmeters:**

#### **1. Number of measurement ranges:**

The basic range of any DVM is either 1V or 10 V. With the help of attenuator at the input, the range can be extended from few microvolts to kilovolts.

#### **2. Number of digits in readout:** The number of digits of DVMs vary from 3 to 6.

More the number of digits, more is the resolution.

#### **3. Accuracy:** The accuracy depends on resolution and resolution on number of digits. Hence more number of digits means more accuracy. The accuracy is as high upto $\pm 0.005\%$ of the reading.

**4. Speed of the reading:** In the digital voltmeters, it is necessary to convert analog signal into digital signal. The various techniques are used to achieve this conversion. The circuits which are used to achieve such conversion are called digitizing circuits and the process is called digitizing. The time required for this conversion is called digitizing period. The maximum speed of reading and the digitizing period are interrelated. The instrument user must wait, till a stable reading is obtained as it is impossible to follow the visual readout at high reading speeds.

**5. Normal mode noise rejection:** This is usually obtained through the input filtering or by use of the integration techniques. The noise present at the input, if passed to the analog to digital converting circuit then it can produce the error, especially when meter is used for low voltage measurement. Hence noise is required to be filtered.

**6. Common mode noise rejection :** This is usually obtained by guarding. A guard is a sheet metal box surrounding the circuitry. A terminal at the front panel makes this 'box' available to the circuit under measurement.

**7. Digital output of several types:** The digital readout of the instrument may be 4 line BCD, single line serial output etc. Thus the type of digital output also determines the variety of the digital voltmeter.

**8. Input impedance :** The input impedance of DVM must be as high as possible which reduces the loading effects. Typically it is of the order of  $10^8 \text{ } \Omega$ .

### Block diagram of DVM:

Any digital instrument requires analog to digital converter at its input. Hence first block in a

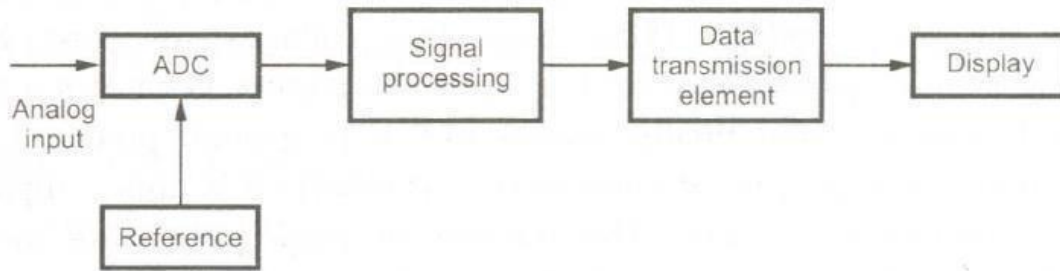

general DVM is ADC as shown in the Fig.

Every ADC requires a reference. The reference is generated internally and reference generator circuitry depends on the type of ADC technique used. The output of ADC is decoded and signal is processed in the decoding stage. Such a decoding is necessary to drive the seven segment display. The data from decoder is then transmitted to the display. The data transmission element may be a latches, counters etc. as per the requirement. A digital display shows the necessary digital result of the measurement.

### Ramp type DVM:

#### Linear ramp technique:

The basic principle of such measurement is based on the measurement of the time taken by a linear ramp to rise from a  $V$  to the level of the input voltage or to decrease from the level of the input voltage to zero. This time is measured with the help of electronic time interval counter and the count is displayed in the numeric form with the help of a digital display.

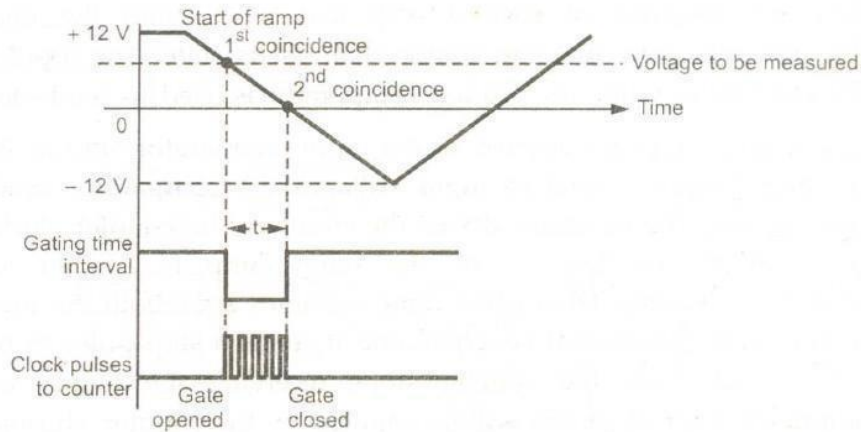

Basically it consists of a linear ramp which is positive going or negative going. The range of the ramp is  $\pm 12$  V while the base range is  $\pm 10$  V. The conversion from a *voltage* to cl time interval is shown in the fig

At the start of measurement, a ramp *voltage* is initiated which is continuously compared with the input voltage. When these two voltages are same, the comparator generates a pulse which opens a gate i.e. the input comparator generates a start pulse. The ramp continues to decrease and finally reaches to 0 V or ground potential. This is sensed by the second comparator or ground comparator. At exactly 0 V, this comparator produces a stop pulse which closes the gate. The number of clock pulses are measured by the counter. Thus the time duration for which the gate is opened, is proportional to the input voltage. In the time interval between start and stop pulses, the gate remains open and the oscillator circuit drives the counter. The magnitude of the count indicates the magnitude of the input voltage, which is displayed by the display. The block diagram of linear ramp DVM is shown in the Fig

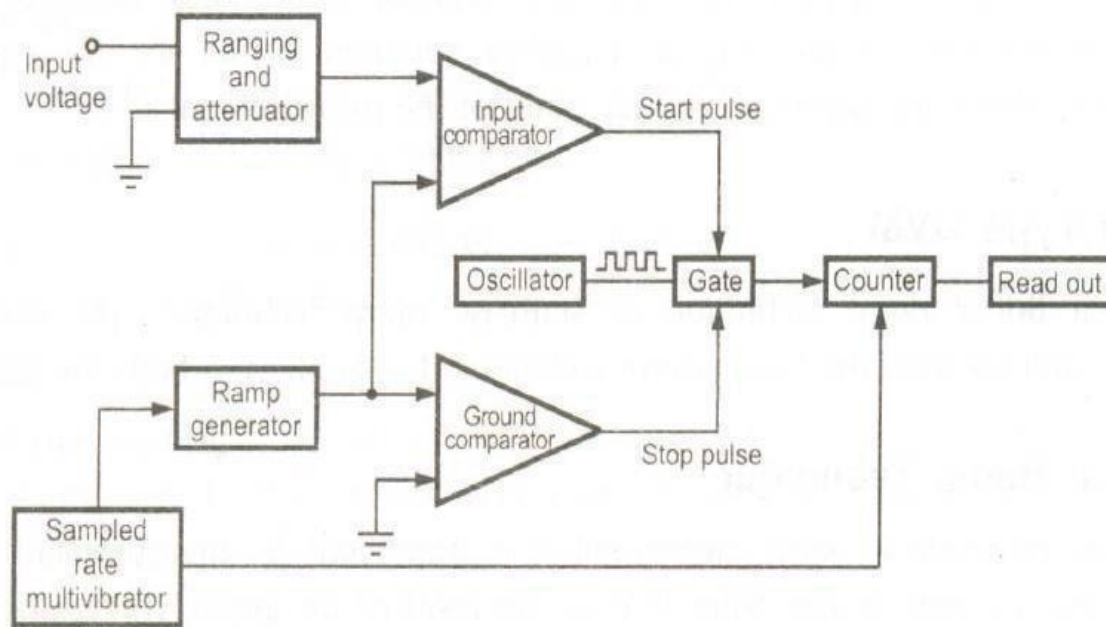

Properly attenuated input signal is applied as one input to the input comparator. The ramp generator generates the proper linear ramp signal which is applied to both the comparators. Initially the logic circuit sends a reset signal to the counter and the readout. The comparators are designed in such a way that when both the input signals of comparator are equal then only the comparator changes its state. The input comparator is used to send the start pulse while the ground comparator is used to send the stop pulse.

When the input and ramp are applied to the input comparator, and at the point when negative going ramp becomes equal to input voltages the comparator sends start pulse, due to which gate opens. The oscillator drives the counter. The counter starts counting the pulses received from the oscillator. Now the same ramp is applied to the ground comparator and it is decreasing.

Thus when ramp becomes zero, both the inputs of ground comparator becomes zero (grounded) i.e. equal and it sends a stop pulse to the gate due to which gate gets closed. Thus the counter stops receiving the pulses from the local oscillator. A definite number of pulses will be counted by the counter, during the start and stop pulses which is measure of the input voltage. This is displayed by the digital readout.'

The sample rate multivibrator determines the rate at which the measurement cycles are initiated. The oscillation of this multivibrator is usually adjusted by a front panel control named rate, from few cycles per second to as high as 1000 or more cycles per second. The typical value is 5 measuring cycles/second with an accuracy of  $\pm 0.005\%$  of the reading.

The sample rate provides an initiating pulse to the ramp generator to start its next ramp voltage. At the same time, a reset pulse is also generated which resets the counter to the zero state.

### Dual slope integrating type DVM:

This is the most popular method of analog to digital conversion. In the ramp techniques, the noise can cause large errors but in dual slope method the noise is averaged out by the positive and negative ramps using the process of integration. The basic principle of this method is that the input signal is integrated for a fixed interval of time. And then the same integrator is used to integrate the reference voltage with reverse slope. Hence the name given to the technique is **dual slope** integration technique.

The block diagram of dual slope integrating type DVM is shown in the Fig. It consists of five blocks, an op-amp used as an integrator, a zero comparator, clock pulse generator, a set of decimal

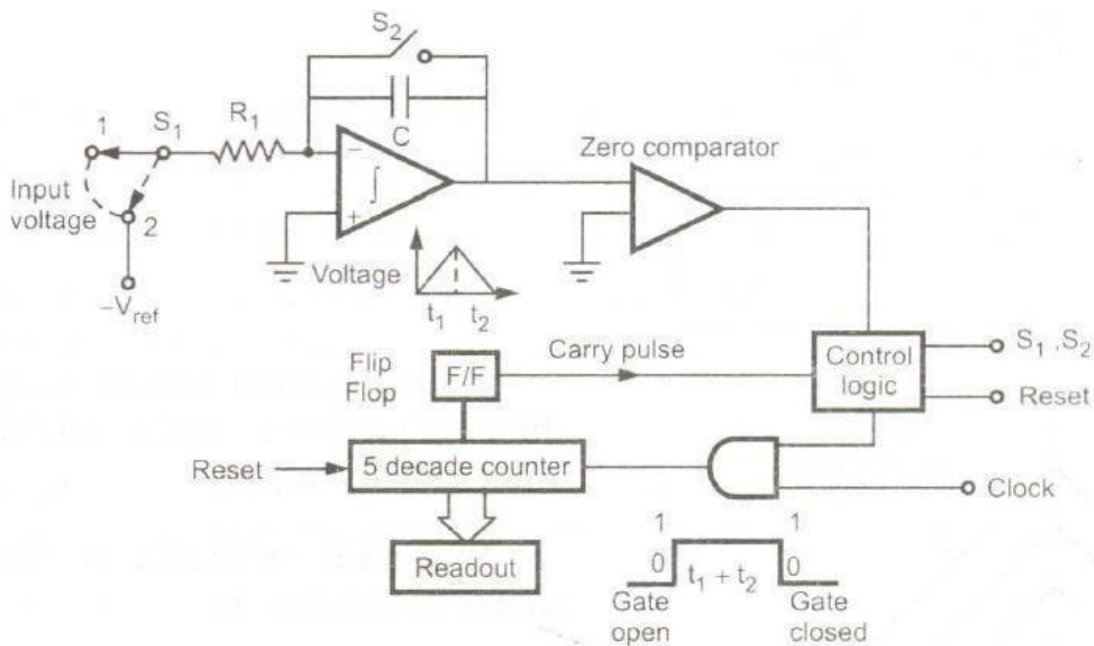

counters and a block of control logic.

When the switch S1 is in position 1, the capacitor C starts charging from zero level. The rate of charging is proportional to the input voltage level. The output of the op-amp is given by,

$$V_{out} = -\frac{1}{R_1 C} \int_0^{t_1} V_{in} dt$$

$$V_{out} = -\frac{V_{in} t_1}{R_1 C}$$

where

$t_1$  = Time for which capacitor is charged

$V_{in}$  = Input voltage

$R_1$  = Series resistance

$C$  = Capacitor in feedback path

After the interval  $t_1$ , the input voltage is disconnected and a negative voltage  $-V_{ref}$  is connected by

$$V_{out} = \frac{1}{R_1 C} \int_0^{t_2} -V_{ref} dt$$

$$V_{out} = -\frac{V_{ref} t_2}{R_1 C}$$

Subtracting (1) from (2),

$$V_{out} - V_{out} = 0 = \frac{-V_{ref} t_2}{R_1 C} - \left( -\frac{V_{in} t_1}{R_1 C} \right)$$

$$\frac{V_{ref} t_2}{R_1 C} = \frac{V_{in} t_1}{R_1 C}$$

$$V_{ref} t_2 = V_{in} t_1$$

$$V_{in} = V_{ref} \cdot \frac{t_2}{t_1}$$

---

throwing the switch S1 in position 2. In this position, the output of the op-amp is given by,

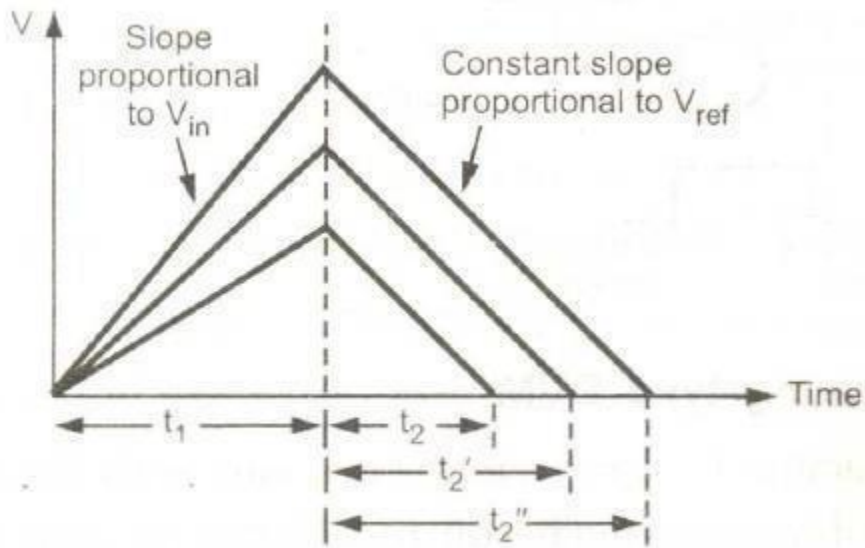

Thus the input voltage is dependent on the time periods  $t_1$  and  $t_2$  and not on the values of  $R$  and  $C$ . This basic principle of this method is shown in the Fig.

At the start of the measurement, the counter is reset to zero. The output of the flip-flop is also zero. This is given to the control logic. This control sends a signal so as to close an electronic switch to position 1 and integration of the input voltage starts. It continues till the time period  $t_1$ .

As the output of the integrator changes from its zero value, the zero comparator output changes its state. This provides a signal to control logic which in turn opens the gate and the counting of the clock pulses starts.

The counter counts the pulses and when it reaches to 9999, it generates a carry pulse and all digits go to zero. The flip flop output gets activated to the logic level T. This activates the control logic. This sends a signal which changes the switch position from 1 to 2. Thus  $-V_{ref}$  gets connected to op-amp. As  $V_{ref}$  polarity is opposite, the capacitor starts discharging. The integrator output will have constant negative slope as shown in the Fig. 3.5.1. The output decreases linearly and after the interval  $t_2$ , attains zero value, when the capacitor  $C$  gets fully discharged.

From equation (3) we can write,

$$V_{in} = V_{ref} \cdot \frac{t_2}{t_1}$$



---

Let time period of clock oscillator be T and digital counter has counted the counts n1 and n2

$$V_{in} = V_{ref} \cdot \frac{n_2 T}{n_1 T} = V_{ref} \cdot \frac{n_2}{n_1}$$

during the period t1 and t2 respectively.

Thus the unknown voltage measurement is not dependent on the clock frequency, but dependent on the counts measured by the counter.

The advantages of this technique are:

- i) Excellent noise rejection as noise and superimposed a.c. are averaged out during the process of integration.
- ii) The RC time constant does not affect the input voltage measurement.
- iii) The capacitor is connected via an electronic switch. This capacitor is an auto zero capacitor and avoids the effects of offset voltage.
- iv) The integrator responds to the average value of the input hence sample and hold circuit is not necessary.
- v) The accuracy is high and can be readily varied according to the specific requirements.

The only disadvantage of this type of DVM is its slow speed.

### **V – F converter type integrating DVM:**

In case of ramp type DVM, the voltage is converted to time. The time and frequency are related to each other. Thus the voltage can be converted to frequency for the measurement purpose. A train of pulses, whose frequency depends upon the voltage being measured, is generated. Then the number of pulses appearing in a definite interval of time is counted. Since the frequency of these pulses is a function of the unknown voltage, the number of pulses counted in that period of time is the indication of the unknown input voltage.



The heart of such integrating type of DVM is the operational amplifier used as an integrator. The input voltage is integrated for a fixed interval. An integration of a constant input



voltage results a ramp at the output, the slope of which is proportional to the input voltage. If the input is positive, the output of op-amp is negative going ramp. After some time, the capacitor is discharged to 0, thus output returns back to zero and the next cycle begins. Hence the waveform at the output is a sawtooth waveform as shown in the Fig.

If the input signal is doubled, the number of teeth in the output signal per unit time will be also doubled. Thus the frequency of the output will be doubled. Thus the frequency of the output is proportional to the input voltage. This is nothing but the voltage to frequency conversion.

The sawtooth pulses are finally enter into a reversible counter. The measured value by the reversible counter is finally displayed with the help of digital readout.

The block diagram of voltage to frequency converter type integrating DVM is shown in the Fig.

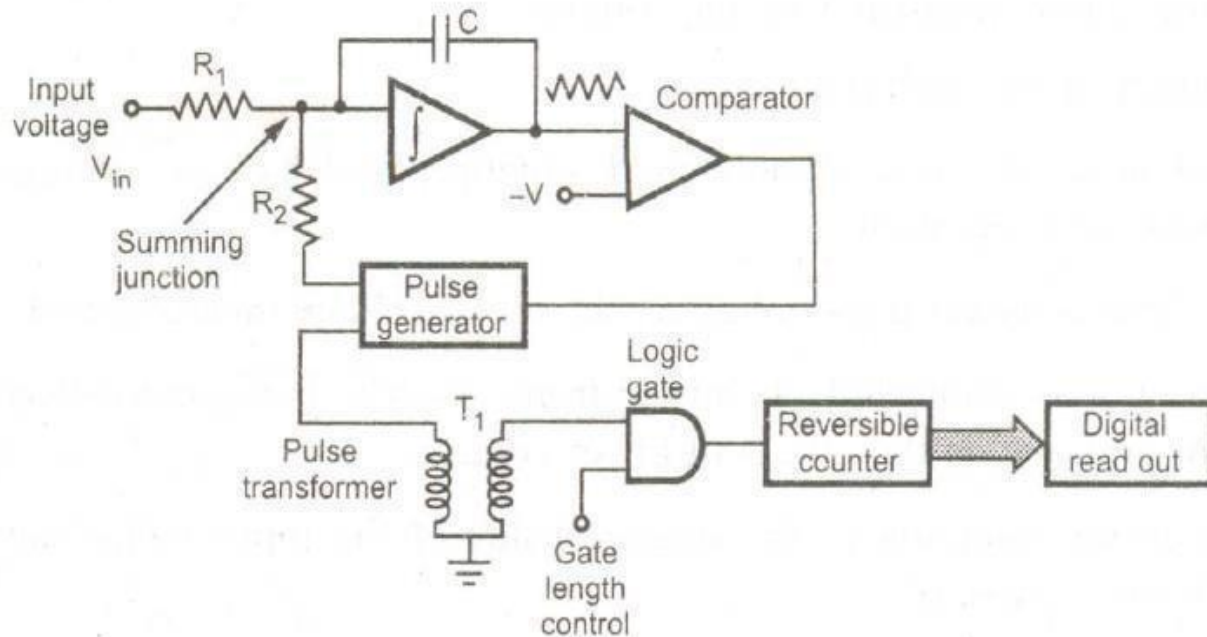

---

Initially output of an integrator is adjusted to zero volts. When the input voltage  $V_i$  is applied, the charging current  $V_i / R_j$  flows, which starts the charging of the capacitor  $C$ . This produces a ramp at the output. When input voltage is positive, the output ramp is negative going. This ramp is given as one input of a comparator. A  $-V$  volts is given as a reference to the second input terminal of a comparator. The negative going ramp and  $-V$  volts reference are compared by the comparator. When the ramp reaches to  $-V$  volts, the comparator output changes its state. This signal triggers the pulse generator. The function of the pulse generator is to produce a pulse of precision charge content. The polarity of this charge is opposite to that of capacitor charge. Thus the pulse generated by the pulse generator rapidly discharges the capacitor. Hence the output of the op-amp again becomes zero. This process continues so as to get a sawtooth waveform at the output of op-amp. The frequency of such waveform is directly proportional to the applied input voltage. Thus if the input voltage increases, the number of teeth per unit time in the sawtooth waveform also increases i.e. the frequency increases.

Each teeth produces a pulse at the output of the pulse generator so number of pulses is directly related to the number of teeth i.e. the frequency. These pulses are allowed to pass through the pulse transformer. These are applied at one input of the gate. Gate length control signal is applied at the other input. The gate length' may be 0.1 sec, 1sec, 20 msec etc. The gate remains open for this much time period.

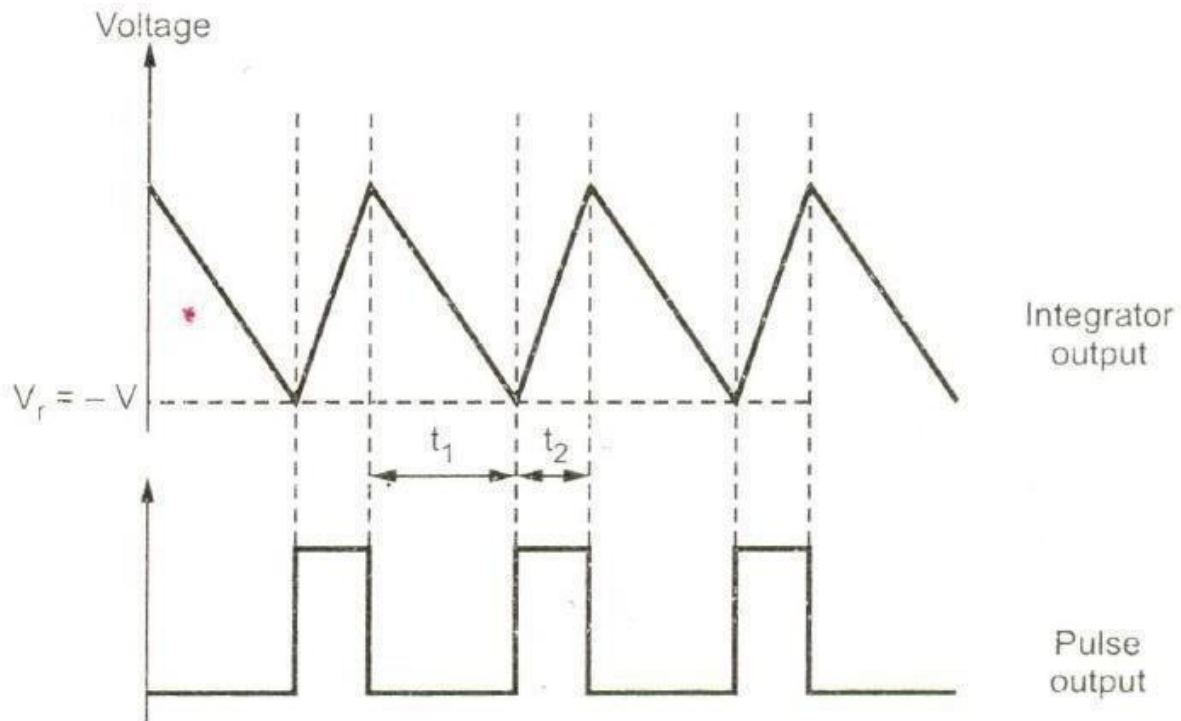

The waveforms of integrator output and output of a pulse generator are shown in the Fig

From the analysis of dual slope technique, we can write,

$$V_{in} = V_r \frac{t_2}{t_1}$$

But in this type, both  $V_r$  and  $t_2$  are constants.

$$K_2 = V_r t_2$$

$$V_{in} = K_2 \left( \frac{1}{t_1} \right) = K_2 (f_o)$$

Accuracy: The accuracy of voltage to frequency conversion technique depends on the magnitude and stability of the charge produced by the pulse generator. Thus the accuracy depends on the precision of the charge feedback in every pulse and also on the linearity, between voltage and frequency.

To obtain the better accuracy the rate of pulses generated by the pulse generator is kept equal to,

i) the voltage time integration of the input signal

ii) the total voltage time areas of the feedback pulses.

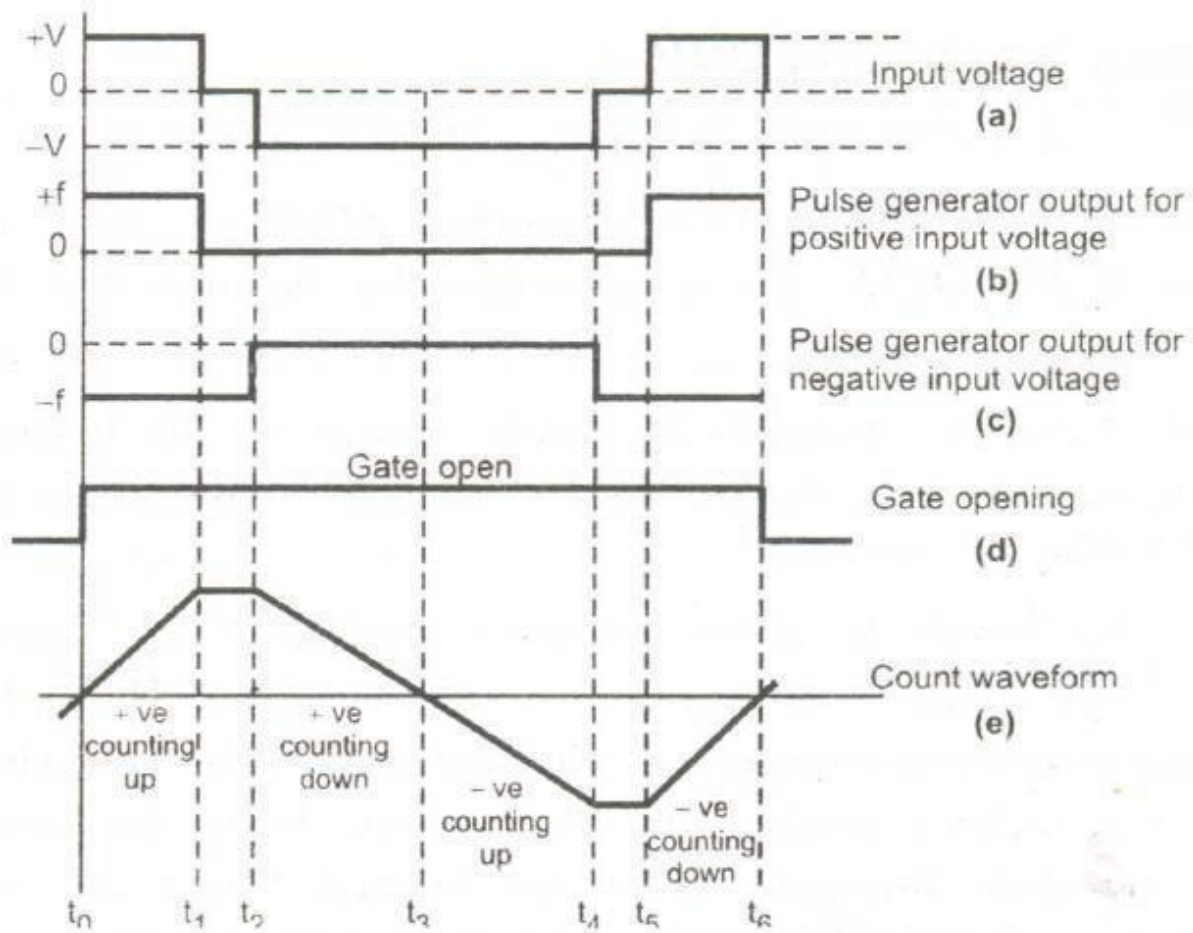

When input voltage polarity is positive i.e. for the periods  $t_0$  to  $t_1$  and  $t_5$  to  $t_6$  the output of the pulse generator is high. For other time period it is low. This is shown in the Fig. When the input voltage polarity is negative i.e. for the period  $t_1$  to  $t_4$  the output of the pulse generator is high. This is due to other pulse generator used for the bipolar voltages. This is shown in the Fig. For the period  $t_0$  to  $t_1$ , it is positive counting up. For the period  $t_2$  to  $t_3$  it is positive counting down. For  $t_3$  to  $t_4$  negative counting up while for the period  $t_5$  to  $t_6$ , it is negative counting down.

**Transfer characteristics :** The transfer characteristics show the relation between the input voltage and the output frequency. This should be as linear as possible. It remains linear upto a frequency called **saturation frequency**. This is shown in the Fig. The slope of both the positive and negative voltage characteristics must be same.

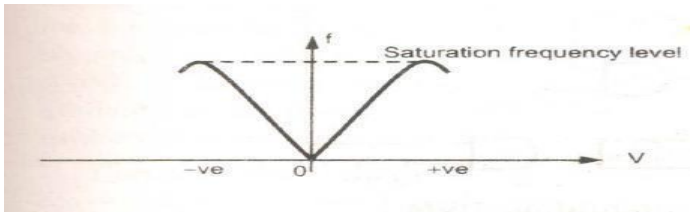

To increase the operating speed of this type of DVM, the upper frequency can be increased i.e. increasing  $VI f$  conversion rate. But this results into reduced accuracy and design cost of such circuit is also very high. Hence another method in which 5 digit resolution is available, is used to increase the speed of operation. This is the modified version of  $VI f$  integrating type DVM and is called interpolating integrating DVM.

### **Interpolating Integrating DVM:**

The block diagram of interpolating integrating DVM is shown in the Fig.

This is a modified version of  $VI f$  integrating DVM. A zero comparator is the additional circuitry in the DVM. The zero comparator ensures that the charge on the capacitor is zero. During first 20 msec, the operation is exactly similar to the normal  $VI f$  integrating DVM. However during this time the pulses are directed to the 100 s decade. Here each pulse is equivalent to the 100 counts.

After 20 msec, the switch  $SI$  is moved from position 1 to 2 and  $V_{rer}$  of opposite polarity is offered. Some charge is still present on the capacitor. The opposite polarity  $V_{rer}$  helps to remove the remaining charge at a constant rate. When the charge reaches zero, the zero comparator provides a pulse to the control logic. When the switch is moved from position 1 to 2, at the same time gate  $G2$  is also opened. Hence the pulses from 50 kHz oscillator can reach to  $I_s$  decade. When the zero comparator provides a pulse, the gate  $G1$  is closed. This completes the reading operation.

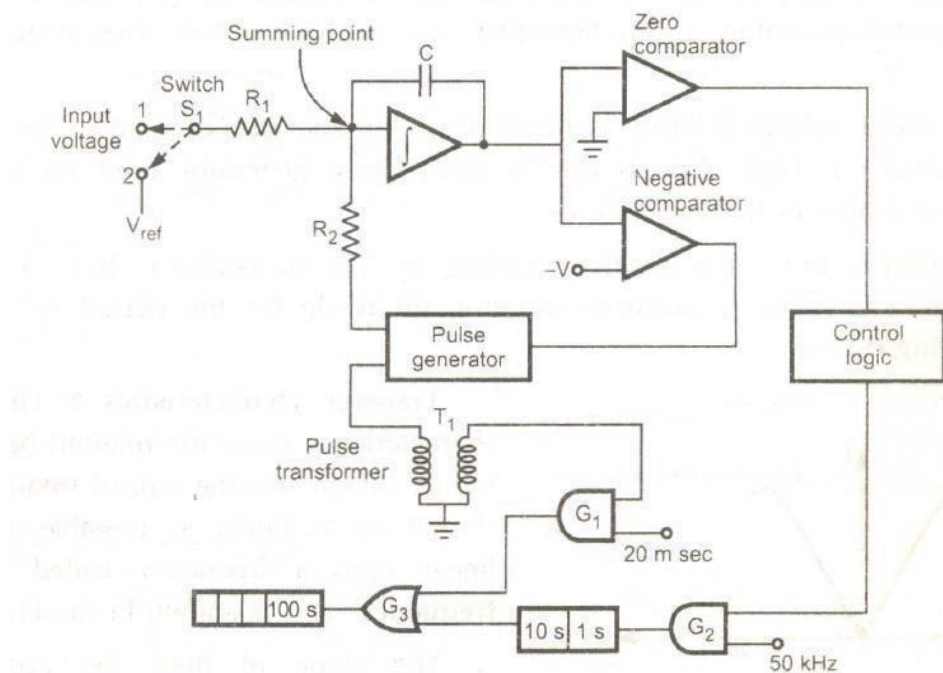

### Successive approximation type DVM:

In successive approximation type DVM, the comparator compares the output of digital to analog converter with the unknown voltage. Accordingly, the comparator provides logic high or low signals. The digital to analog converter successively generates the set pattern of signals. The procedure continues till the output of the digital to analog converter becomes equal to the unknown voltage.

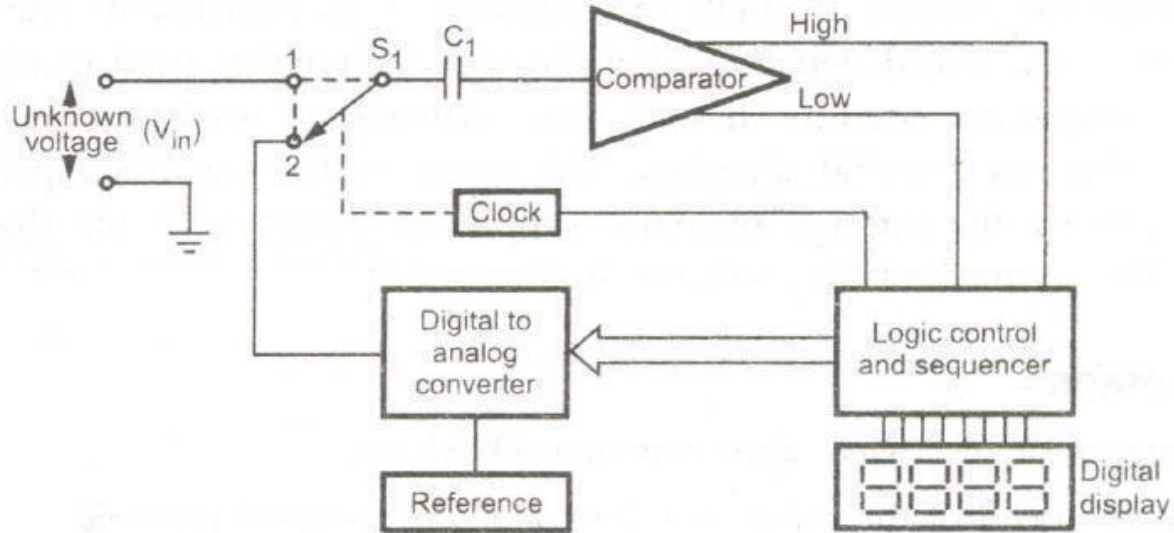

The capacitor is connected at the input of the comparator. The output of the digital to analog converter is compared with the unknown voltage, by the comparator. The output of the comparator is given to the logic control and sequencer. This unit generates the sequence of code which is applied to digital to analog converter. The position 2 of the switch 51 receives the output from digital to analog converter. The unknown voltage is available at the position 1 of the switch S1. The logic control also drives the clock which is used to alternate the switch S1 between the positions 1 and 2, as per the requirement.

### Resolution and sensitivity:

If  $n$  is the number of full digits then the resolution of a DVM is given by,

$$R = \frac{1}{10^n}$$

where  $R$  = Resolution

Thus for 3 digit display,  $n = 3$

$$\therefore R = \frac{1}{10^3} = 10^{-3} = 0.001 \text{ or } 0.1\%$$

The sensitivity is the smallest change in the input which a digital meter should be able to detect. Hence, it is the full scale value of the lowest range multiplied by the resolution of the meter.



$$S = (fs)_{\min} \times R$$

where  $S = \text{Sensitivity}$

$(fs)_{\min} = \text{Full scale value on minimum range.}$

$R = \text{Resolution expressed as decimal.}$

### Digital multimeters:

The digital multimeter is an instrument which is capable of measuring a.c. voltages, d.c. voltages, a.c. and d.c. currents and resistances *over* several ranges. The basic circuit of a digital multimeter

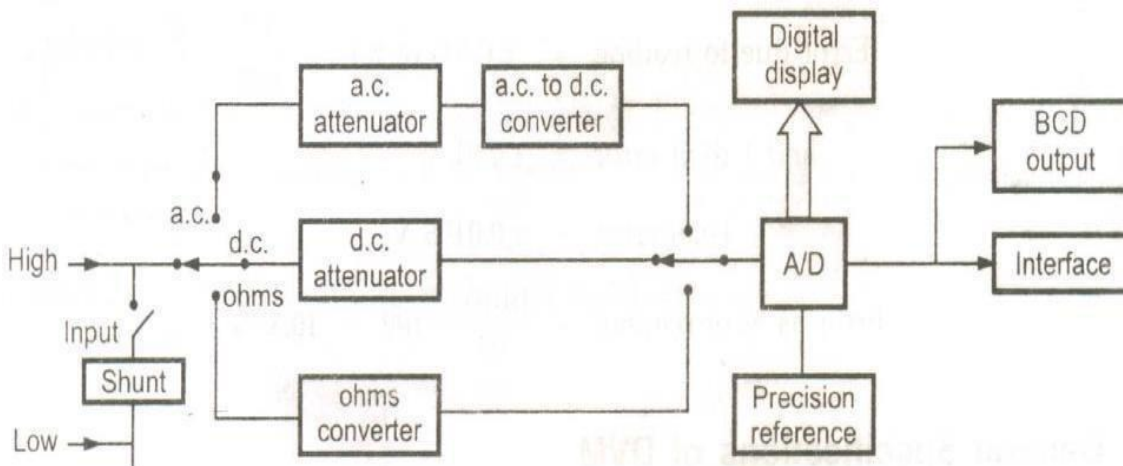

is always a d.c. voltmeter as shown in the Fig

The current is converted to voltage by passing it through low shunt resistance. The a.c. quantities are *converted* to d.c. by employing various rectifier and filtering circuits. While for the resistance measurements the meter consists of a precision low current source that is applied across the unknown resistance while gives d.c. voltage. All the quantities are digitized using analog to digital converter and displayed in the digital form on the display.

The basic building blocks of digital multimeter are several *AID* converters, counting circuitry and an attenuation circuit. Generally dual slope integration type ADC is preferred in the multimeters.



The single attenuator circuit is used for both a.c. and d.c. measurements in many commercial multimeters. The block diagram of a digital multimeter is shown in the Fig.

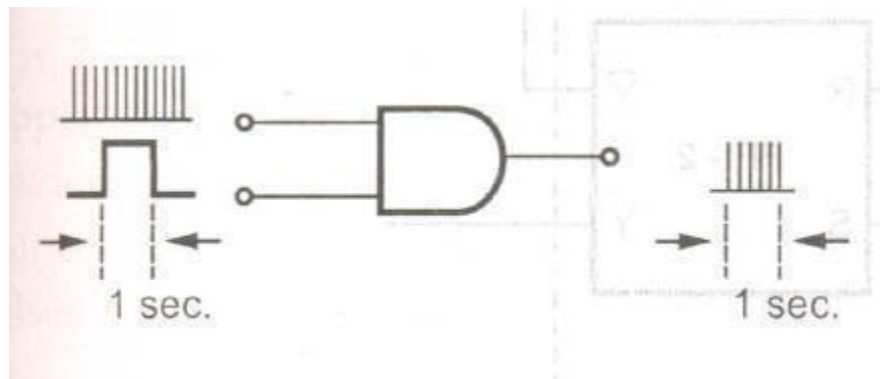
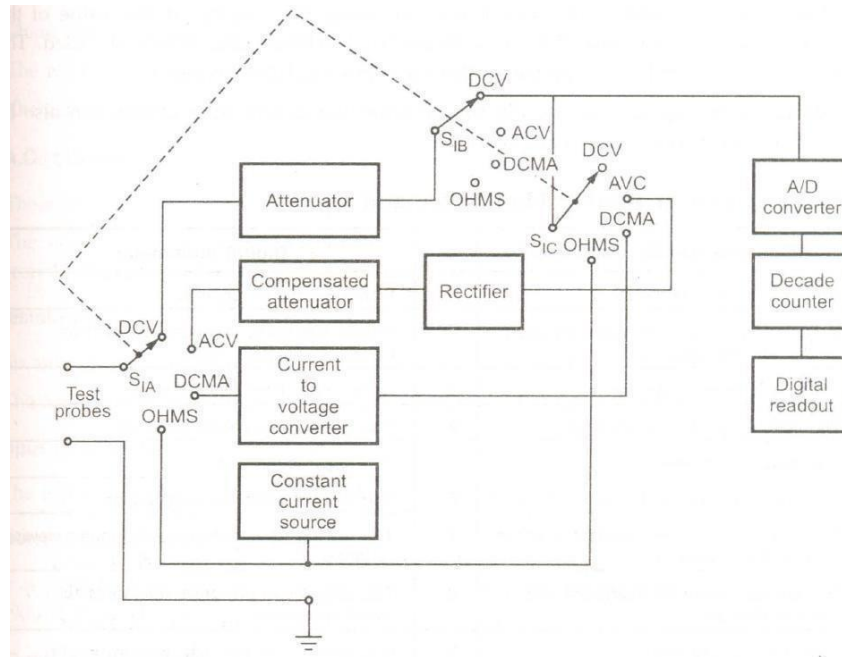

### Digital Frequency meter:

#### Principle:

The signal waveform whose frequency is to be measured is converted into trigger pulses and applied continuously to one terminal of an AND gate. To the other terminal of the gate, a pulse of 1 sec is applied as shown in the Fig. The number of pulses counted at the output terminal during period of 1 sec indicates the frequency.

The signal whose frequency is to be measured is converted to trigger pulses which is nothing but train of pulses with one pulse for each cycle of the signal. At the output terminal of AND gate, the number of pulses in a particular interval of time are counted using an electronic counter. Since each pulse represents the cycle of the unknown signal, the number of counts is a

direct indication of the frequency of the signal which is unknown. Since electronic counter has a high speed of operation, high frequency signals can be measured.

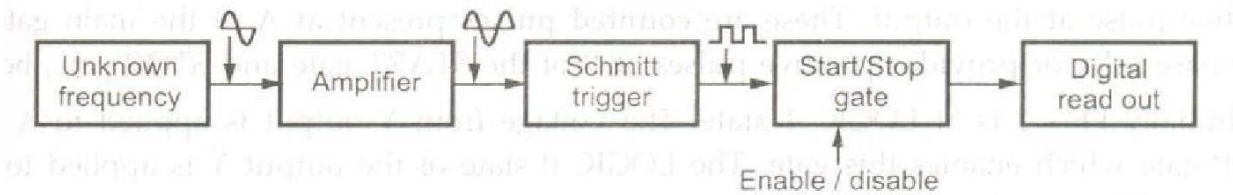

## Block diagram of digital frequency meter

The signal waveform whose frequency is to be measured is first amplified. Then the amplified signal is applied to the schmitt trigger which converts input signal into a square wave with fast rise and fall times. This square wave is then differentiated and clipped. As a result, the output from the schmitt trigger is the train of pulses for each cycle of the signal. The output pulses from the schmitt trigger are fed to a START/STOP gate. When this gate is enabled, the input pulses pass through this gate and are fed directly to the electronic counter, which counts the number of pulses. When this gate is disabled, the counter stops counting the incoming pulses. The counter displays the number of pulses that have passed through it in the time interval between start and stop. If this

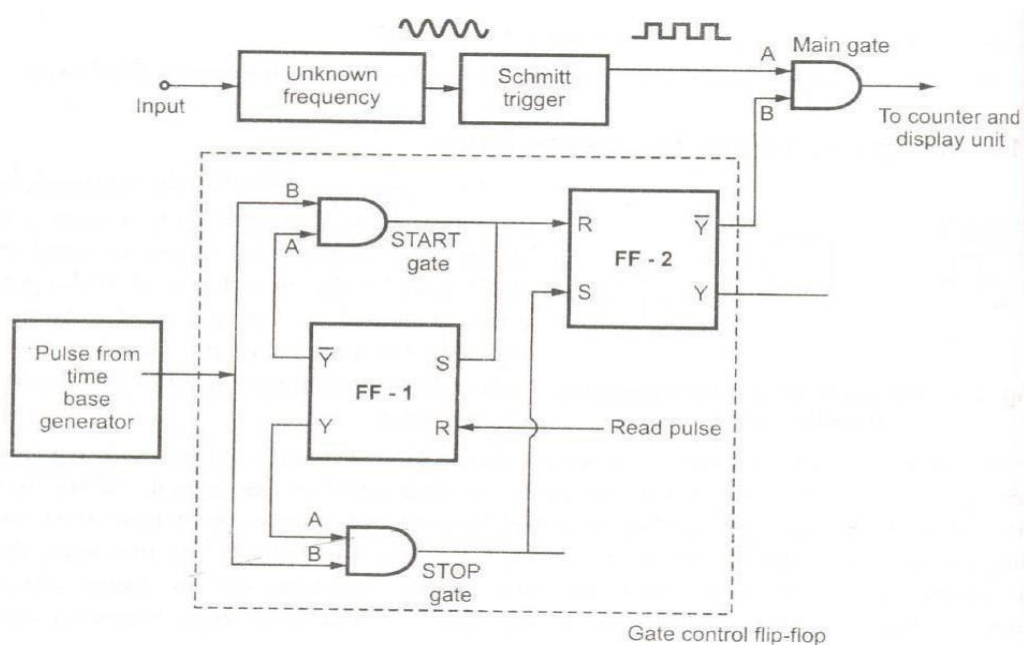

---

interval is known, the unknown frequency can be measured.

The output of unknown frequency is applied to the Schmitt trigger which produces positive pulse at the output. These are **counted pulses** present at A of the timing gate. The time base selector provides positive pulses at B of the START gate and STOP gate, both. Initially FF - 1 is at LOGIC 1 state. The voltage from Y output is applied to A of the STOP gate which enables this gate. The LOGIC a state of the output Y is applied to input A of START gate which disables this gate. When STOP gate enables, positive pulses from the time base pass through STOP gate to S input of FF - 2, setting FF - 2 to LOGIC 1 state. The LOGIC a level of Y of **FF - 2** is connected to B of main gate, which confirms that pulses from unknown frequency source can't pass through the main gate. By applying a positive pulse to R input of FF - 1, the operation is started. This changes states of the FF - 1 to  $Y = 1$  and  $Y = 0$ . Due to this, STOP gate gets disabled, while START gate gets enabled. The same pulse is simultaneously applied to all decade counters to reset all of them, to start new counting.

With the next pulse from the time base passes through START gate resetting FF - 2 and it changes state from LOGIC a to LOGIC 1. As Y changes from a to 1, the gating signal is applied to input B of the main gate which enables the main gate.

Now the pulses from source can pass, through the main gate to the counter. The counter counts pulses. The state of FF - 1 changes from a to 1 by applying same pulse from START gate to S input of FF - 1. Now the START gate gets disabled, while STOP gate gets enabled. It is important that the pulses of unknown frequency pass through the main gate to counter till the main gate is enabled.

The next pulse from the time base generator passes through STOP Gate to S input of FF - 2. This sets output back to 1 and  $Y = 0$ . Now main gate gets disabled. The source supplying pulses of unknown frequency gets disconnected. In between this pulse and previous pulse from the time base selector, the number of pulses are counted by the counter. When the interval of time between two pulses is 1 second, then the count of pulses indicates the frequency of the unknown frequency source.

### **1. Input signal conditioning circuit :**

In this circuit, an amplifier and schmitt trigger are included. The threshold voltage of the schmitt trigger can be controlled by sensitivity control on the control panel. First of all the input signal of

---

unknown frequency is fed into input signal conditioning circuit. There the signal is amplified and then it is converted into square wave by schmitt trigger circuit.

## **2. Time base generator:**

The crystal oscillator produces a signal of 1 MHz or 100 MHz depending upon the requirement. In general, the accuracy of the digital frequency counter depends on the accuracy of the time base signals produced, thus the temperature compensated crystal oscillator is used. The output of the oscillator is passed through another schmitt trigger circuit producing square wave output. Then it is fed to frequency dividers connected in cascade. Thus a train of pulses are obtained after each frequency divider section. Using time base selector switch the Gate **Time** can be adjusted. The gating circuit consists of AND gate. When the enable signal is provided to the AND gate, it allows a train of pulses to pass through the gate for the time period selected by the time base circuit. The pulses are counted and then the second pulse generated from the time base generator disables AND gate and thus closes it.

In this unit, decade counters are connected in the cascade. The output of the AND gate is connected to the clock input of the first decade counter. Then the output of this counter is connected to the clock input of next and so on. Using these counters the number of pulses are counted and are displayed by the display unit. As the number of pulses counted are proportional to the input signal frequency, the final display is proportional to the unknown frequency of the input signal.

## **Period measurement:**

Using the frequency counter, the period measurement is possible. As we know, time period  $T = 1/f$ . If the frequency to be measured is low, then the accuracy of the frequency counter decreases as less number of pulses are connected to the gating circuit.

Thus in low frequency region it is better to measure period rather than frequency. The block diagram of the period mode of the digital frequency counter is as shown in the Fig.\

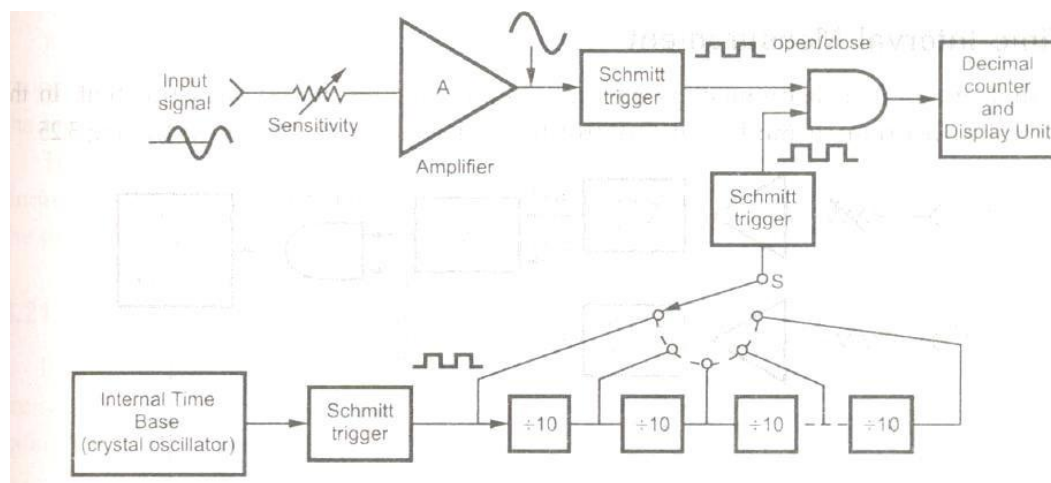

The main difference in the frequency mode and period mode of the digital frequency counter is that the unknown input signal controls the gate time of the gating circuit while the time base frequency is counted in the decade counter assembly. Note that in the period mode, the input signal conditioning circuit produces a train of pulses. So the positive going zero crossing pulses are used as trigger pulses for opening and closing of AND gate in the gating circuit. The main advantage of the period mode is that the accuracy is greater for the low frequency input signals.

**Time interval measurement:**

The time interval measurement is basically similar to the period measurement. In the time interval measurement mode, gate control flip flop is used as shown in the Fig

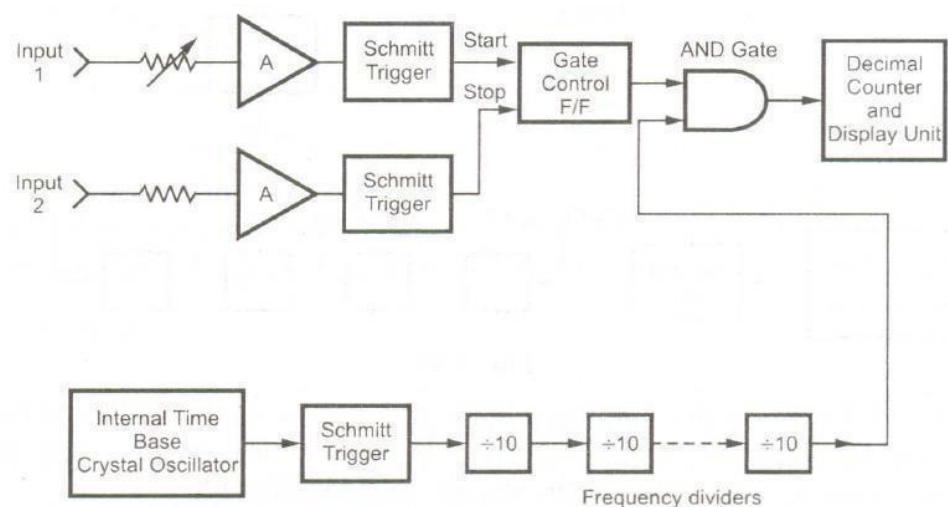

In this measurement mode, two inputs are used to start and stop the counting. Here similar to the period measurement, the internal frequency pulses generated by time base generator circuit are counted. The start and stop signals are derived from two inputs. The AND gate is enabled with the external input 1 applied. The counting of the pulses starts at this instant. The AND gate is disabled with the input 2 applied. Thus pulses are counted in the time interval which is proportional to the time interval between application of inputs 1 and 2.

### Frequency ratio measurement:

By using the frequency counter, the ratio of two frequencies can be measured. It is again similar

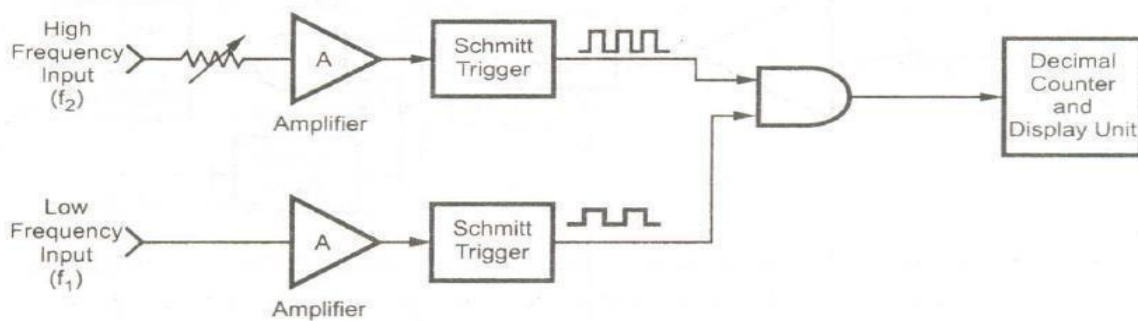

to period measurement. The block diagram is as shown in the Fig.

In this mode, the low frequency signal is used as gating signal, while the pulses are counted for the high frequency signal. Hence it is clear that the low frequency represents the time base.

The number of pulses corresponding to the high frequency signal  $f_2$  are counted during the period of the low frequency signal  $f_1$ , by the decade counters and displayed by the display unit.

---

## UNIT-II OSCILLOSCOPES

### INTRODUCTION

In studying the various electronic, electrical networks and systems, signals which are functions of time, are often encountered. Such signals may be periodic or non periodic in nature. The device which allows, the amplitude of such signals, to be displayed primarily as "function of time, is called cathode ray oscilloscope, commonly known as C.R.O. The C.R.O gives the visual representation of the time varying signals. The oscilloscope has become an universal instrument and is probably most versatile tool for the development of electronic circuits and systems. It is an integral part of electronic laboratories.

The oscilloscope is, in fact, a voltmeter. Instead of the mechanical deflection of a metallic pointer as used in the normal voltmeters, the oscilloscope uses the movement of an electron beam against a fluorescent screen, which produces the movement of a visible spot. The movement of such spot on the screen is proportional to the varying magnitude of the signal, which is under measurement.

### BASIC PRINCIPLE:

The electron beam can be deflected in two directions: the horizontal or x-direction and the vertical or y-direction. Thus an electron beam producing a spot can be used to produce two dimensional displays, Thus CRO. can be regarded as a fast x-y plotter. The x-axis and y-axis can be used to study the variation of one voltage as a function of another. Typically the x-axis of the oscilloscope represents the time while the y-axis represents variation of the input voltage signal.

Thus if The input voltage signal applied to the y-axis of CRO. is sinusoidally varying and if x-axis represents the time axis, then the spot moves sinusoidally, and the familiar sinusoidal waveform can be seen on the screen of the oscilloscope. The oscilloscope is so fast device that it can display the periodic signals whose time period is as small as microseconds and even nanoseconds. The CRO basically operates on voltages, but it is possible to convert current, pressure, strain, acceleration and other physical quantities into the voltage using transducers and obtain their visual representations on the CRO.



## BLOCK DIAGRAM OF SIMPLE OSCILLOSCOPE

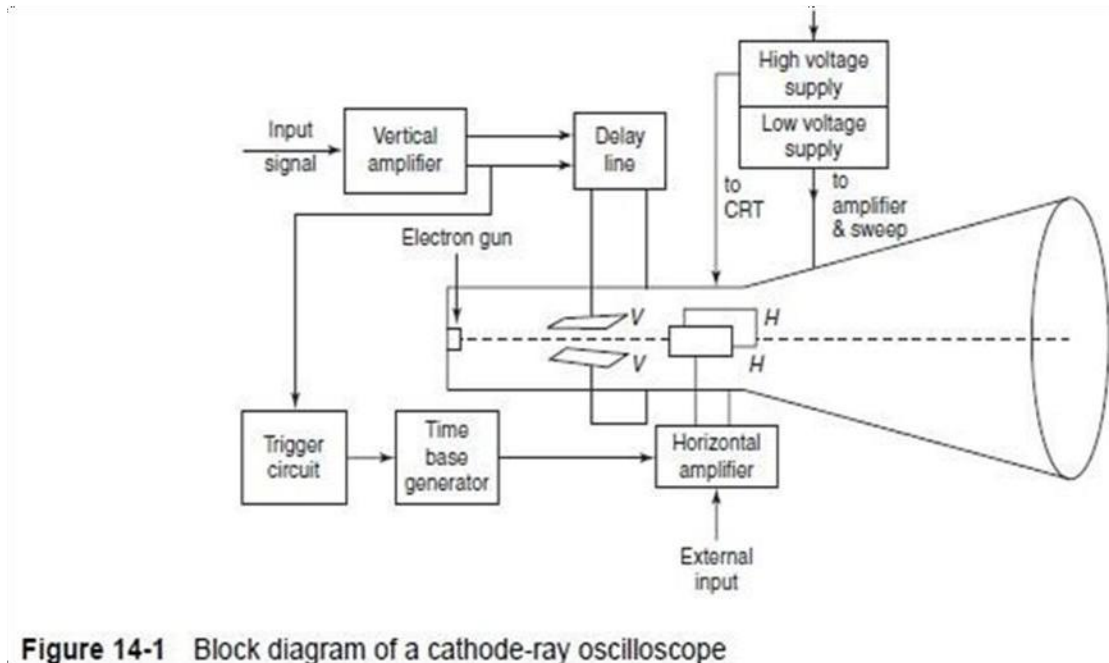

**Figure 14-1** Block diagram of a cathode-ray oscilloscope

### COMPONENTS OF THE CATHODE-RAY OSCILLOSCOPE

The CRO consists of the following:

- (i) CRT
- (ii) Vertical amplifier
- (iii) Delay line
- (iv) Horizontal amplifier
- (v) Time-base generator
- (vi) Triggering circuit
- (vii) Power supply

#### **CRT:**

The cathode ray tube is the vacuum tube which converts the electrical signal into the visual signal. The cathode ray tube mainly consists the electron gun and the electrostatic deflection plates (vertical and horizontal).The electron gun produces a focused beam of the electron which is accelerated to high frequency. The vertical deflection plate moves the beams up and down and the horizontal beam moved the electrons beams left to right. These movements are independent to each other and hence the beam may be positioned anywhere on the screen.

#### **ELECTRON GUN**



---

The electron gun emits the electrons and forms them into a beam. The electron gun mainly consists a heater, cathode, a grid, a pre-accelerating anode, a focusing anode and an accelerating anode. For gaining the high emission of electrons at the moderate temperature, the layers of barium and strontium is deposited on the end of the cathode. After the emission of an electron from the cathode grid, it passes through the control grid. The control grid is usually a nickel cylinder with a centrally located co-axial with the CRT axis. It controls the intensity of the emitted electron from the cathode. The electron while passing through the control grid is accelerated by a high positive potential which is applied to the pre-accelerating or accelerating nodes. The electron beam is focused on focusing electrodes and then passes through the vertical and horizontal deflection plates and then goes on to the fluorescent lamp. The pre-accelerating and accelerating anode are connected to 1500v, and the focusing electrode is connected to 500 v. There are two methods of focusing on the electron beam. These methods are

- Electrostatic focusing
- Electromagnetic focusing.
- The CRO uses an electrostatic focusing tube.

#### **DEFLECTING PLATE**

The electron beam after leaving the electron gun passes through the two pairs of the deflecting plate. The pair of plate producing the vertical deflection is called a vertical deflecting plate or Y plates, and the pair of the plate which is used for horizontal deflection is called horizontal deflection plate or X plates.

#### **FLUORESCENT SCREEN FOR CRT**

The front of the CRT is called the face plate. It is flat for screen sized up to about 100mm×100mm. The screen of the CRT is slightly curved for larger displays. The face plate is formed by pressing the molten glass into a mould and then annealing it.

The inside surface of the faceplate is coated with phosphor crystal. The phosphor converts electrical energy into light energy. When an electronics beam strike phosphor crystal, it raises their

energy level and hence light is emitted during phosphorous crystallization. This phenomenon is called fluorescence.

### GLASS ENVELOPE

It is a highly evacuated conical shape structure. The inner surface of the CRT between the neck and the screen is coated with the aquadag. The aquadag is a conducting material and act as a high-voltage electrode. The coating surface is electrically connected to the accelerating anode and hence help the electron to be the focus.

### WORKING OF CATHODE RAY OSCILLOSCOPE

When the electron is injected through the electron gun, it passes through the control grid. The control grid controls the intensity of electron in the vacuum tube. If the control grid has high negative potential, then it allows only a few electrons to pass through it. Thus, the dim spot is produced on the lightning screen. If the negative potential on the control grid is low, then the bright spot is produced. Hence the intensity of light depends on the negative potential of the control grid.

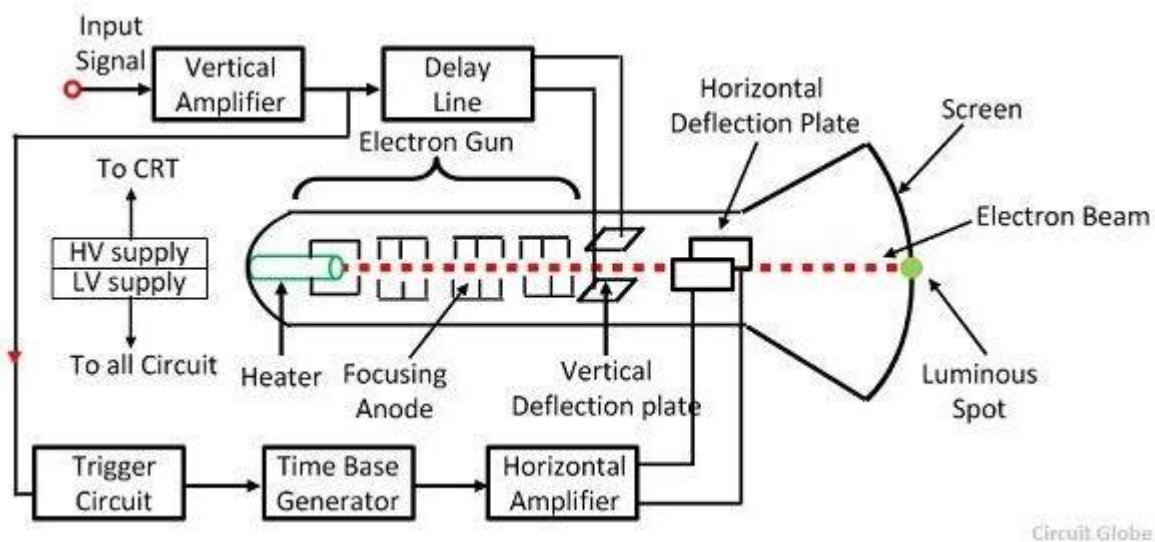

After moving the control grid the electron beam passing through the focusing and accelerating anodes. The accelerating anodes are at a high positive potential and hence they converge the beam at a point on the screen.

---

After moving from the accelerating anode, the beam comes under the effect of the deflecting plates. When the deflecting plate is at zero potential, the beam produces a spot at the centre. If the voltage is applied to the vertical deflecting plate, the electron beam focuses at the upward and when the voltage is applied horizontally the spot of light will be deflected horizontally.

**CATHODE RAY TUBE (CRT):**

The cathode ray tube (CRT) is the heart of the CR.O. The CRT generates the electron beam, accelerates the beam, deflects the beam and also has a screen where beam becomes visible, as a spot.

The main parts of the CRT are:

- i) Electron gun
- ii) Deflection system
- iii) Fluorescent screen
- iv) Glass tube or envelope
- v) Base

A schematic diagram of CRT, showing its structure and main components is shown

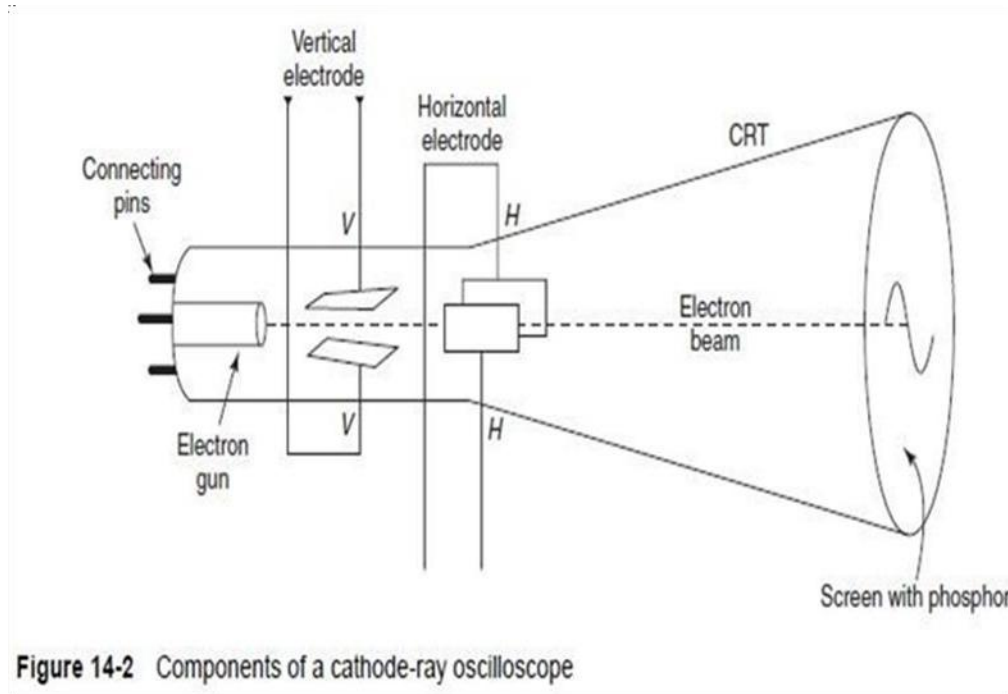

Figure 14-2 Components of a cathode-ray oscilloscope

#### **ELECTRON GUN:**

The electron gun section of the cathode ray tube provides a sharply focused electron beam directed towards the fluorescent-coated screen. This section starts from the thermally heated cathode, limiting the electrons. The control grid is given a negative potential with respect to cathode dc. This grid controls the number of electrons in the beam, going to the screen.

The momentum of the electrons (their number  $\times$  their speed) determines the intensity, or brightness, of the light emitted from the fluorescent screen due to the electron bombardment. The light emitted is usually of the green color. Because the electrons are negatively charged, a repulsive force is created by applying a negative voltage to the control grid (in CRT, voltages applied to various grids are stated with respect to cathode, which is taken as common point). This negative control voltage can be made variable.

#### **DEFLECTION SYSTEM:**

When the electron beam is accelerated it passes through the deflection system, with which beam can be positioned anywhere on the screen. The deflection system of the cathode-ray-tube consists of two pairs of parallel plates, referred to as the vertical and horizontal deflection plates. One of the plates in each set is connected to ground (0 V). To the other plate of each set, the external deflection voltage is applied through an internal adjustable gain amplifier stage. To apply the deflection voltage externally, an external terminal, called the Y input or the X input, is available.

---

As shown in the Fig. , the electron beam passes through these plates. A positive voltage applied to the Y input terminal ( $V_y$ ) Causes the beam to deflect vertically upward due to the attraction forces, while a negative voltage applied to the Y input terminal will cause the electron beam to deflect vertically downward, due to the repulsion forces. When the voltages are applied simultaneously to vertical and horizontal deflecting plates, the electron beam is deflected due to the resultant of these two voltages.

#### **FLUORESCENT SCREEN:**

The light produced by the screen does not disappear immediately when bombardment by electrons ceases, i.e., when the signal becomes zero. The time period for which the trace remains on the screen after the signal becomes zero is known as "persistence". The persistence may be as short as a few microseconds, or as long as tens of seconds and minutes.

Long persistence traces are used in the study of transients. Long persistence helps in the study of transients since the trace is still seen on the screen after the transient has disappeared.

#### **PHOSPHOR SCREEN CHARACTERISTICS:**

Many phosphor materials having different excitation times and colors as well as different phosphorescence times are available. The type P1, P2, P11 or P31 are the short persistence phosphors and are used for the general purpose oscilloscope

Medical oscilloscopes require a longer phosphor decay and hence phosphors like P7 and P39 are preferred for such applications. Very slow displays like radar require long persistence phosphors to maintain sufficient flicker free picture. Such phosphors are P19, P26 and, P33. The phosphors P19, P26, P33 have low burn resistance. The phosphors P1, P2, P4, P7, P11 have medium burn resistance while P1S, P3I have high burn resistance.

#### **DEFLECTION SYSTEMS**

To deflect the beam horizontally, an alternating voltage is applied to the horizontal deflecting plates and the spot on the screen horizontally, as shown in Figure. The electrons will focus at point X2. By changing the polarity of voltage, the beam will focus at point X1. Thus, the horizontal movement is controlled along X1OX2 line.

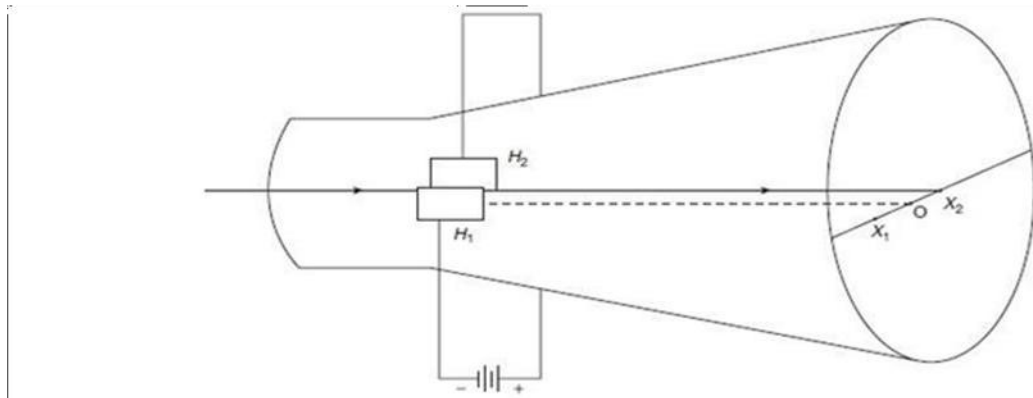

Figure 14-3(b) Deflecting system using parallel horizontal plate

### DISPLAY WAVEFORM ON THE SCREEN

A sine wave applied to vertical deflecting plates and a repetitive ramp or saw-tooth applied to the horizontal plates. The ramp waveform at the horizontal plates causes the electron beam to be deflected horizontally across the screen. If the waveforms are perfectly synchronized then the exact sine wave applied to the vertical display appears on the CRO display screen.

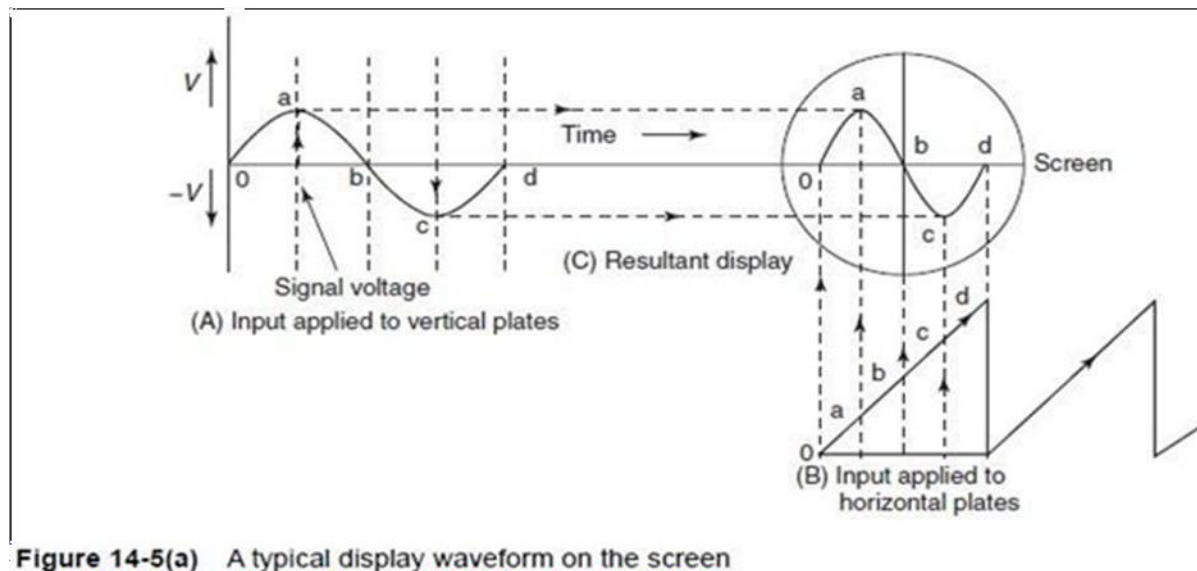

Figure 14-5(a) A typical display waveform on the screen

### TIME-BASE GENERATOR USING UJT

To improve the sweep linearity, two separate voltage supplies are used; a low voltage supply for the UJT and a high voltage supply for the RTCT circuit. This circuit is as shown in Figure below. CRT is used for continuous control of frequency within a range and CT is varied or changed in steps. They are sometimes known as timing resistor and timing capacitor.

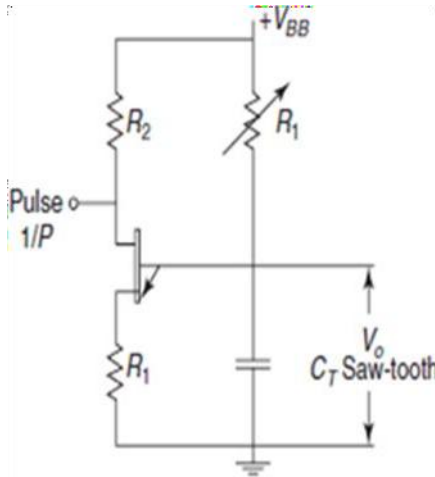

Figure 14-7 (c) Time-base generator using UJT

## OSCILLOSCOPE AMPLIFIERS

The purpose of an oscilloscope is to produce a faithful representation of the signals applied to its input terminals.

The oscillographic amplifiers can be classified into two major categories.

- AC-coupled amplifiers
- DC-coupled amplifiers

The low-cost oscilloscopes generally use ac-coupled amplifiers. The dc-coupled amplifiers are quite expensive.

DC-coupled amplifiers have another advantage. They eliminate the problems of low-frequency phase shift and waveform distortion while observing low-frequency pulse train.

The amplifiers can be classified according to bandwidth use also:

- Narrow-bandwidth amplifiers
- Broad-bandwidth amplifiers

Vertical amplifiers determine the sensitivity and bandwidth of an oscilloscope. Sensitivity, which is expressed in terms of V/cm of vertical deflection at the mid-band frequency. The gain of the vertical amplifier determines the smallest signal that the oscilloscope can satisfactorily measure by reproducing it on the CRT screen. The sensitivity of an oscilloscope is directly proportional to the gain of the vertical amplifier. So, as the gain increases the sensitivity also increases. The vertical sensitivity measures how much the electron beam will be deflected for a specified input signal. The CRT screen is covered with a

plastic grid pattern called a graticule. The spacing between the grids lines is typically 10 mm. Vertical sensitivity is generally expressed in volts per division. The vertical sensitivity of an oscilloscope measures the smallest deflection factor that can be selected with the rotary switch.

### Delay line circuit

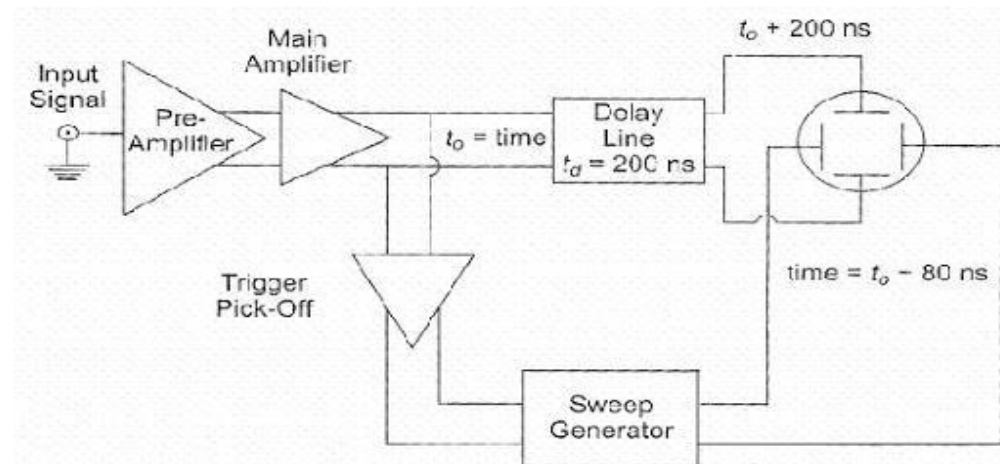

fig 3.1 Delay Line Circuit

The delay line is used to delay the signal for some time in the vertical sections. When the delay line is not used, the part of the signal gets lost. Thus the input signal is not applied directly to the vertical plates but is delayed by some time using a delay line circuit as shown in the Fig.

If the trigger pulse is picked off at a time  $t = t_o$  after the signal has passed through the main amplifier then signal is delayed by  $XI$  nanoseconds while sweep takes  $YI$  nanoseconds to reach. The design of delay line is such that the delay time  $XI$  is higher than the time  $YI$ . Generally  $XI$  is 200 nsec while is 80 ns, thus the sweep starts well in time and no part of the signal is lost.

There are two types of delay lines used in CR.O.

which are:

- i) Lumped parameter delay line



---

ii) Distributed parameter delay line

**Trigger circuit:**

It is necessary that horizontal deflection starts at the same point of the input vertical signal, each time it sweeps. Hence to synchronize horizontal deflection with vertical deflection a synchronizing or triggering circuit is used. It converts the incoming signal into the triggering pulses, which are used for the synchronization.

**Time base generator:**

The time base generator is used to generate the sawtooth voltage, required to deflect the beam in the horizontal section. This voltage deflects the spot at a constant time dependent rate. Thus the x-axis' on the screen can be represented as time, which, helps to display and analyse the time varying signals.

**Applications of CRO:**

1. Measurement of voltage – Voltage waveform will be made on the oscilloscope screen. From the screen of the CRO, the voltage can be measured by seeing its amplitude variation on the screen.
2. Measurement of current – Current waveform will be read from the oscilloscope screen in the similar way as told in above point. The peak to peak, maximum current value can be measured from the screen.
3. Measurement of phase – Phase measurement in CRO can be done by the help of Lissajous pattern figures. Lissajous figures can tell us about the phase difference between two signals. Frequency can also be measured by this pattern figure.
4. Measurement of frequency – Frequency measurement in cathode ray oscilloscope can be made with the help of measuring the time period of the signal to be measured.

High frequency CRT or Travelling wave type CRT:

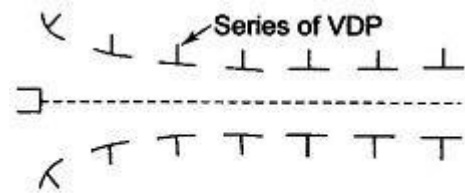

**Fig. 7.17** Travelling Wave CRO

In an ordinary CRO, there is only one pair of VDPs. When the signal to be displayed is of a very high frequency, the electron beam does not get sufficient time to pick up the instantaneous level of the signal. Also, at high frequencies the numbers of electrons striking the screen in a given time and the intensity of the beam is reduced. Hence, instead of one set of vertical deflection plates, a series of vertical deflection plates are used. The plates are so shaped and spaced that an electron travelling along the CRT receives from each set of plates an additional deflecting force in proper time sequence. This synchronisation is achieved by making the signal travel from one plate to the next at the same speed as the transit time of the electrons. The signal is applied to each pair of plates, and as the electron beam travels the signal also travels through the delay lines. The time delays are so arranged that the same electrons are deflected by the input signal. In this way the electron beam picks up the level of the input signal. The time delays between the plates correspond exactly to the transit times of the electrons.

#### **Characteristics of a HF CRO or (HF Improvement in a CRO)**

- The vertical amplifier must be designed both for high B.W. and high sensitivity or gain. Making the vertical amplifier a fixed gain amplifier simplifies the design. The input to the amplifier is brought to the required level by means of an attenuator circuit. The final stages is the push-pull stage.
- The LF CRT is replaced by an HF CRT.
- A probe is used to connect the signals, e.g. a high Z passive probe acts like a compensated attenuator.
- By using a triggered sweep, for fast rising signals, and by the use of delay lines between the vertical plates, for improvement of HF characteristics.
- 5. New fluorescent materials that increase the brightness of the display are used.

**Feature :**

- Highest Sensitivity up to 1mV/div (After Expand)
- Full band Trig Auto Sweep Circuit
- Flex Trig mode (Select either CH1 or CH2 Signal / External Signal)
- Alt-Trig View 2 in relative Signal
- Ext Trig Input
- Power Supply : AC 200 ±10% V

**Specification :**

- BandWidth AC 10Hz ~ 30MHz (-3dB) DC ~ 30MHz (-3dB)
- Y Deflection 5mV / div ~ 20V / div
- Rise Time Oscilloscope < 18ns, Mag x 5 Accuracy : <5%
- Max Input 400V(DC+ACp-p)
- Sweep Mode Auto, Trig, Lock, Single
- Sweep Rate 0.1µs/div ~ 0.2s/div 1—2—5 20 steps, error ±5%
- Trig Source Y1, Y2, ALT, Line, Ext, TV-H, TV-V
- Min Sync. Level Trig DC ~ 30MHz, Int. 1 div, Ext. 0.2Vp-p, TV Int. 2div, Ext. 0.3Vp-p Trig Lock (50Hz ~ 10MHz) Internal 2div

• <b>Freq. Response</b>	<b>Min Input Level</b>
AC : 10Hz ~ 1MHz -3dB	TTL Level
DC : 0 ~ 1MHz -3dB	<b>WaveForm</b>
<b>Z Max. Input</b>	Square wave
400V (DC+ACp-p)	<b>Frequency</b>
<b>Amplitude</b>	1KHz ±2%
0.5Vp-p ±2%	

- 
- Standard Accessory : Power Chord, Two 20MHz Oscilloscope Probes, Manual
  - Dimensions : 320 x 130 x 400mm

Special purpose oscilloscopes just by including few additional blocks to the basic oscilloscope based on the requirement.

Following are the special purpose oscilloscopes.

- Dual Beam Oscilloscope
- Dual Trace Oscilloscope
- Digital Storage Oscilloscope

### **Dual Beam Oscilloscope:**

Another method of studying two voltages simultaneously on the screen is to use a special cathode ray tube having two separate electron guns generating two separate beams. Each electron beam has its own vertical deflection plates.

But the two beams are deflected horizontally by the common set of horizontal plates. The time base circuit may be same or different. Such an oscilloscope is called Dual Beam Oscilloscope.

The oscilloscope has two vertical deflection plates and two separate channels A and B for the two separate input signals. Each channel consists of a preamplifier and an attenuator. A delay line, main vertical amplifier and a set of vertical deflection plates together forms a single channel. There is a single set of horizontal plates and single time base circuit. The sweep generator drives the horizontal amplifier which in turn drives the plates. The horizontal plates sweep both the beams across the screen at the same rate. The sweep generator can be triggered internally by the channel A signal or channel B signal. Similarly it can also be triggered from an external signal or line frequency signal. This is possible with the help of trigger selector switch, a front panel control. Such an oscilloscope may have separate timebase circuit for separate channel. This allows different sweep rates for the two channels but increases the size and weight of the oscilloscope.

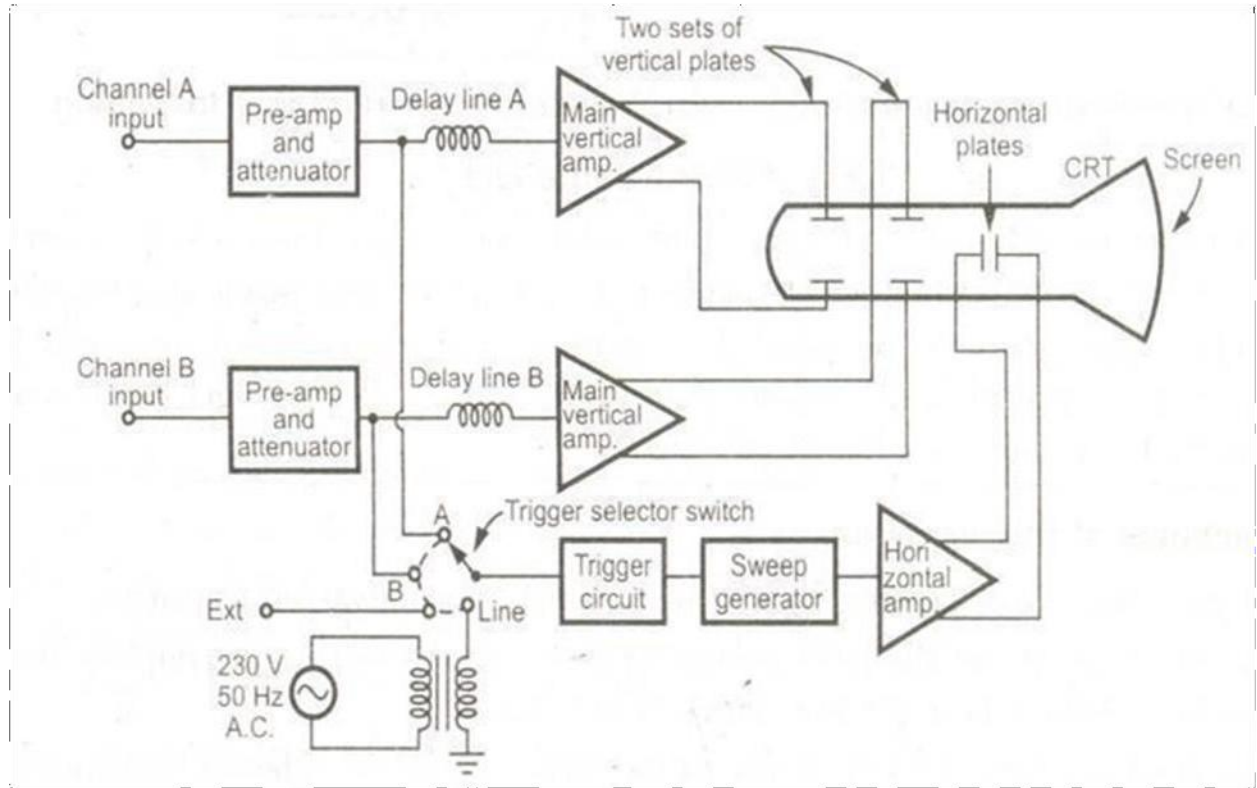

**Dual trace oscilloscope:**

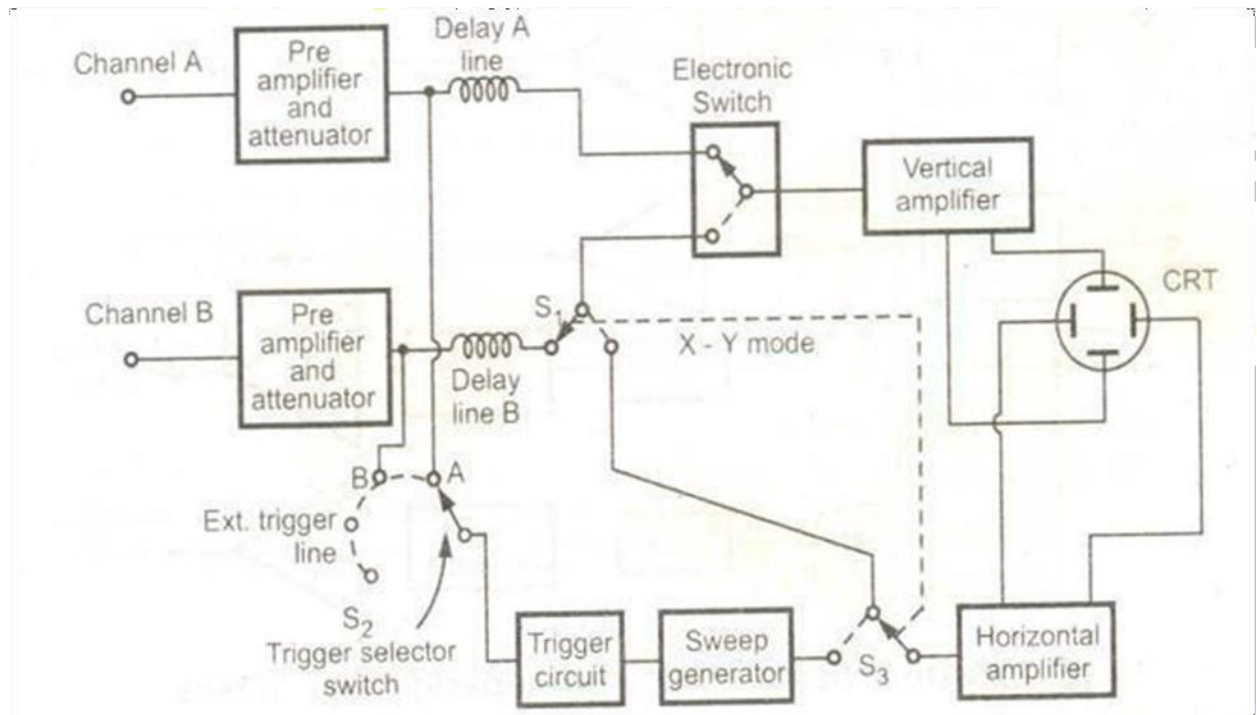

---

The comparison of two or more voltages is very much necessary in the analysis and study of many electronic circuits and systems. This is possible by using more than one oscilloscope but in such a case it is difficult to trigger the sweep of each oscilloscope precisely at the same time. A common and less costly method to solve this problem is to use dual trace or multitrace oscilloscopes. In this method, the same electron beam is used to generate two traces which can be deflected from two independent vertical sources. The methods are used to generate two independent traces which the alternate sweep method and other is chop method. The block diagram of dual trace oscilloscope is shown in the Fig.

There are two separate vertical input channels A and B. A separate preamplifier and - attenuator stage exists for each channel. Hence amplitude of each input can be individually controlled. After preamplifier stage, both the signals are fed to an electronic switch. The switch has an ability to pass one channel at a time via delay line to the vertical amplifier. The time base circuit uses a trigger selector switch 52 which allows the circuit to be triggered on either A or B channel, on line frequency or on an external signal. The horizontal amplifier is fed from the sweep generator or the B channel via switch 5! and 51. The X-Y mode means, the oscilloscope operates from channel A as the vertical signal and the channel B as the horizontal signal. Thus in this mode very accurate X-Y measurements can be done.

Special purpose oscilloscopes just by including few additional blocks to the basic oscilloscope based on the requirement.

Following are the special purpose oscilloscopes.

- Dual Beam Oscilloscope
- Dual Trace Oscilloscope
- Digital Storage Oscilloscope

In this digital storage oscilloscope, the waveform to be stored is digitised ,md then stored in a digital memory. The conventional cathode ray tube is used in this oscilloscope hencethe cost is less. The power to be applied to memory is small and can be supplied by small battery. Due to this the stored image can be displayed indefinitely as long ,15 power is supplied to memory. Once the waveform is digitised then it can be further loaded into thecomputer and can be ana lysed in detail.

### **Block Diagram:**

The block diagram of digital storage oscilloscope is shown in the Fig.

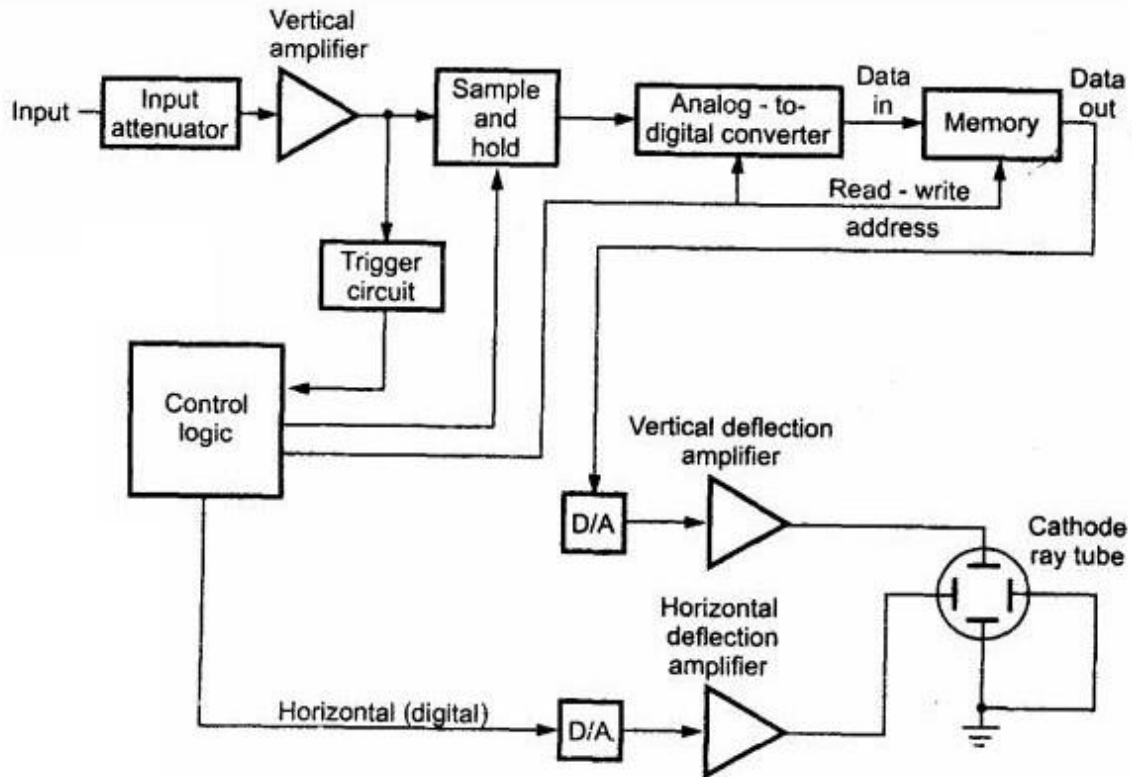

As done in all the oscilloscopes, the input signal is applied to the amplifier and attenuator section. The oscilloscope uses same type of amplifier and attenuator circuitry as used in the conventional oscilloscopes. The attenuated signal is then applied to the vertical amplifier.

The vertical input, after passing through the vertical amplifier, is digitised by an analog to digital converter to create a data set that is stored in the memory. The data set is processed by the microprocessor and then sent to the display.

To digitise the analog signal, analog to digital (A/D) converter is used. The output of the vertical amplifier is applied to the A/D converter section. The main requirement of A/D converter in the digital storage oscilloscope is its speed, while in digital voltmeters accuracy and resolution were the main requirements. The digitised output needed only in the binary form and not in BCD. The successive approximation type of A/D converter is most oftenly used in the digital storage oscilloscopes.

The digital storage oscilloscope has three

1. Roll mode
2. Store mode
3. Hold or save mode.

---

## Advantages

- i) It is easier to operate and has more capability.
- ii) The storage time is infinite.
- iii) The display flexibility is available. The number of traces that can be stored and recalled depends on the size of the memory.

## **Sampling Time Base:**

The time base circuit of the sampling oscilloscope is different than the conventional oscilloscope.

The time base of sampling oscilloscope has two functions:

- i) To move the dots across the screen
- ii) To generate the sampling command pulses for the sampling circuit.

It consists of synchronous circuit, which determines the sampling rate and establishes a reference point in time with respect to the input signal. The time base generates a triggering pulse which activates the oscillator to generate a ramp voltage. Similarly it generates a stair case waveform. The ramp generation is based on the output of the synchronizing circuit.

Both the ramp as well as staircase waveforms are applied to a voltage comparator. This comparator compares the two voltages and whenever these two voltages are equal, it generates a sampling pulse. This pulse then momentarily bias the diodes of the sampling gate in the forward direction and thus diode switch gets closed for short duration of time.

The capacitor charges but for short time hence, it can charge to only a small percentage of the input signal value at that instant. This voltage is amplified by the vertical amplifier and then applied to the vertical deflecting plates. This is nothing but a sample. At the same time, the comparator gives a signal to the staircase generator to advance through one step. This is applied to horizontal deflecting plates, thus during each step of the stair case waveform, the spot moves across the screen. Thus the sampling time base is called a staircase-ramp generator in case of a sampling oscilloscope.

## **Block diagram of Sampling Oscilloscope:**

The block diagram of sampling oscilloscope is shown in the Fig.



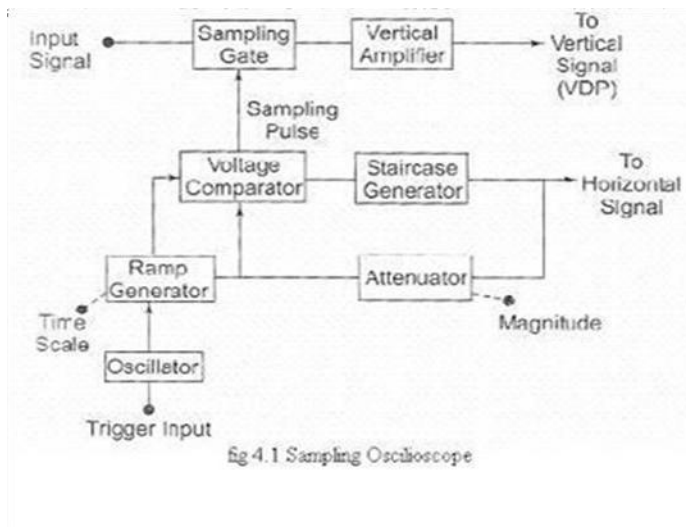

The input signal is applied to the diode sampling gate. At the start of each sampling cycle a trigger input pulse is generated which activates the blocking oscillator. The oscillator output is given to the ramp generator which generates the linear ramp signal. Since the sampling must be synchronized with the input signal frequency, the signal is delayed in the vertical amplifier. The staircase generator produces a staircase waveform which is applied to an attenuator. The attenuator controls the magnitude of the staircase signal and then it is applied to a voltage comparator. Another input to the voltage comparator is the output of the ramp generator. The voltage comparator compares the two signals and produces the output pulse when the two voltages are equal. This is nothing but a sampling pulse which is applied to sampling gate through the gate control circuitry.

This pulse opens the diode gate and sample is taken in. This sampled signal is then applied to the vertical amplifier and the vertical deflecting plates. The output of the staircase generator is also applied to the horizontal deflecting plates.

During each step of staircase the spot moves on the screen. The comparator output advances the staircase output through one step. After certain number of pulses about thousand or so, the staircase generator resets. The smaller the size of the steps of the staircase generator, larger is the number of samples and higher is the resolution of the image.

### Lissajous figures:

When both pairs of the deflection plates (horizontal deflection plates and vertical deflection plates) of CRO (Cathode Ray Oscilloscope) are connected to two sinusoidal voltages, the patterns appear at CRO

screen are called the Lissajous pattern. Shape of these Lissajous pattern changes with changes of phase difference between signal and ration of frequencies applied to the deflection plates (traces) of CRO. Which makes these Lissajous patterns very useful to analysis the signals applied to deflection plated of CRO. These lissajous patterns have two Applications to analysis the signals. To calculate the phase difference between two sinusoidal signals having same frequency. To determine the ratio frequencies of sinusoidal signals applied to the vertical and horizontal deflecting plates.

Lissajous figure can be displayed by applying two a.c. signals simultaneously to the X-plates and Y-plates of an oscilloscope. As the frequency, amplitude and phase difference are altered, different patterns are seen on the screen of the CRO

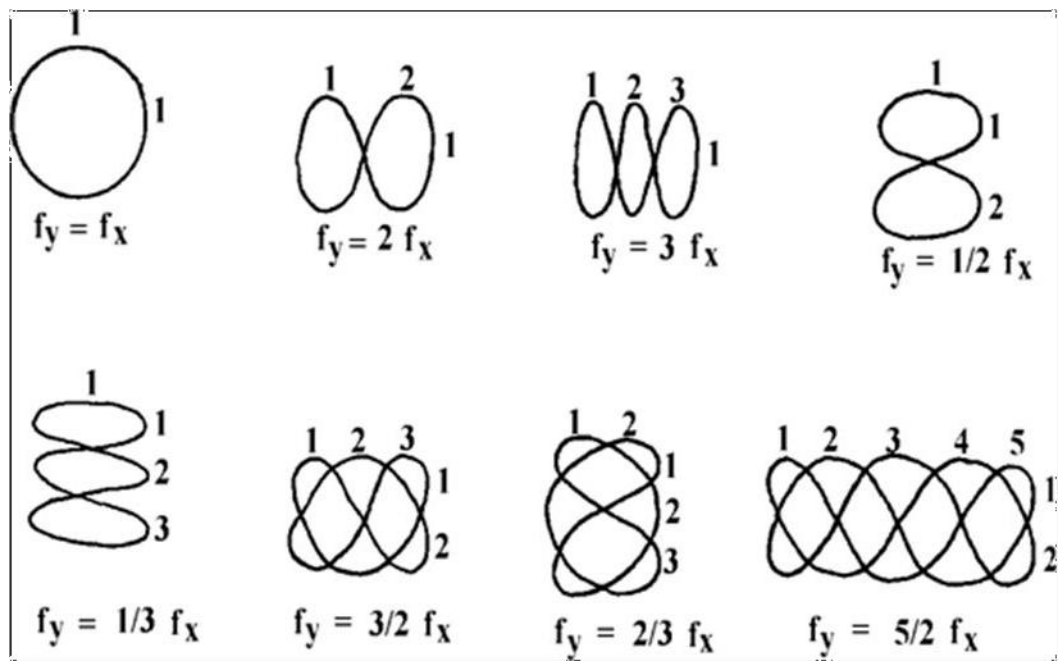

To determine the ratio of frequencies of signal applied to the vertical and horizontal deflecting plates:

To determine the ratio of frequencies of signal by using the Lissajous pattern, simply draw arbitrary horizontal and vertical line on lissajous pattern intersecting the Lissajous pattern. Now count the number of horizontal and vertical tangencies by Lissajous pattern with these horizontal and vertical line.

Then the ratio of frequencies of signals applied to deflection plates,

$$\frac{\omega_y}{\omega_x} = \frac{f_y}{f_x} = \frac{\text{Number of horizontal tangencies}}{\text{Number of vertical tangencies}}$$

Or,

$$\frac{\omega_y}{\omega_x} = \frac{f_y}{f_x} = \frac{(\text{Number of intersections of lissajous pattern with horizontal line})}{(\text{Number of intersections of lissajous pattern with horizontal line})}$$

There are two cases to determine the phase difference  $\phi$  between two signals applied to the horizontal & vertical plates, Case - I: When,  $0^\circ < \phi < 90^\circ$  or  $270^\circ < \phi < 360^\circ$ .

As we studied above it clear that when the angle is in the range of  $0 < \phi < 90^\circ$  or  $270^\circ < \phi < 360^\circ$ , the Lissajous pattern is of the shape of Ellipse having major axis passing through origin from first quadrant to third quadrant.

Case - II: When,  $90^\circ < \phi < 180^\circ$  or  $180^\circ < \phi < 270^\circ$ .

As we studied above it Clear that when the angle is in the range of  $0^\circ < \phi < 90^\circ$  or  $270^\circ < \phi < 360^\circ$ , the Lissajous Pattern is of the shape of Ellipse having major axis passing through origin from second quadrant to fourth quadrant.

### Measurements using Lissajous Figures:

We can do the following two measurements from a Lissajous figure.

- Frequency of the sinusoidal signal
- Phase difference between two sinusoidal signals

Now, let us discuss about these two measurements one by one.

### Measurement of Frequency

Lissajous figure will be displayed on the screen, when the sinusoidal signals are applied to both horizontal & vertical deflection plates of CRO. Hence, apply the sinusoidal signal, which has standard known frequency to the horizontal deflection plates of CRO. Similarly, apply the sinusoidal signal, whose frequency is unknown to the vertical deflection plates of CRO

Let,  $f_H$  and  $f_V$  are the frequencies of sinusoidal signals, which are applied to the horizontal & vertical deflection plates of CRO respectively. The relationship between  $f_H$  and  $f_V$  can be mathematically represented as below.

$$f_V f_H = n H n V f_H = n H n V$$

From above relation, we will get the frequency of sinusoidal signal, which is applied to the vertical deflection plates of CRO as

$$f_V = (n H n V) f_H \quad \text{(Equation 1)}$$

---

Where,

$n_H$  is the number of horizontal tangencies

$n_V$  is the number of vertical tangencies

We can find the values of  $n_H$  and  $n_V$  from Lissajous figure. So, by substituting the values of  $n_H$ ,  $n_V$  and  $f_H$  in Equation 1, we will get the value of  $f_V$ , i.e. the frequency of sinusoidal signal that is applied to the vertical deflection plates of CRO.

### Measurement of Phase Difference

A Lissajous figure is displayed on the screen when sinusoidal signals are applied to both horizontal & vertical deflection plates of CRO. Hence, apply the sinusoidal signals, which have same amplitude and frequency to both horizontal and vertical deflection plates of CRO.

For few Lissajous figures based on their shape, we can directly tell the phase difference between the two sinusoidal signals.

- If the Lissajous figure is a straight line with an inclination of  $45^\circ$  with positive x-axis, then the phase difference between the two sinusoidal signals will be  $0^\circ$ . That means, there is no phase difference between those two sinusoidal signals.
- If the Lissajous figure is a straight line with an inclination of  $135^\circ$  with positive x-axis, then the phase difference between the two sinusoidal signals will be  $180^\circ$ . That means, those two sinusoidal signals are out of phase.
- If the Lissajous figure is in circular shape, then the phase difference between the two sinusoidal signals will be  $90^\circ$  or  $270^\circ$ .

We can calculate the phase difference between the two sinusoidal signals by using formulae, when the Lissajous figures are of elliptical shape.

- If the major axis of an elliptical shape Lissajous figure having an inclination angle lies between  $0^\circ$  and  $90^\circ$  with positive x-axis, then the phase difference between the two sinusoidal signals will be.

$$\phi = \sin^{-1}\left(\frac{x_1 x_2}{y_1 y_2}\right) = \sin^{-1}\left(\frac{x_1}{y_1} \cdot \frac{x_2}{y_2}\right)$$

- If the major axis of an elliptical shape Lissajous figure having an inclination angle lies between  $90^\circ$  and  $180^\circ$  with positive x-axis, then the phase difference between the two sinusoidal signals will be.

$$\phi = 180 - \sin^{-1}\left(\frac{x_1 x_2}{y_1 y_2}\right) = 180 - \sin^{-1}\left(\frac{x_1}{y_1} \cdot \frac{x_2}{y_2}\right)$$

Where,

---

$x_1$  is the distance from the origin to the point on x-axis, where the elliptical shape Lissajous figure intersects

$x_2$  is the distance from the origin to the vertical tangent of elliptical shape Lissajous figure

$y_1$  is the distance from the origin to the point on y-axis, where the elliptical shape Lissajous figure intersects

$y_2$  is the distance from the origin to the horizontal tangent of elliptical shape Lissajous figure

In this chapter, we learnt how to find the frequency of unknown sinusoidal signal and the phase difference between two sinusoidal signals from Lissajous figures by using formulae.

### **Oscilloscope probes:**

Oscilloscopes are widely used for test and repair of electronics equipment of all types. However it is necessary to have a method of connecting the input of the oscilloscope to the point on the equipment under test that needs monitoring. To connect the scope to the point to be monitored it is necessary to use screened cable to prevent any pick-up of unwanted signals and in addition to this the inputs to most oscilloscopes use coaxial BNC connectors. While it is possible to use an odd length of coax cable with a BNC connector on one end and open wires with crocodile / alligator clips on the other, this is not ideal and purpose made oscilloscope probes provide a far more satisfactory solution.

Oscilloscope probes normally comprise a BNC connector, the coaxial cable (typically around a metre in length) and what may be termed the probe itself. This comprises a mechanical clip arrangement so that the probe can be attached to the appropriate test point, and an earth or ground clip to be attached to the appropriate ground point on the circuit under test. Care should be taken when using oscilloscope probes as they can break. Although they are robustly manufactured, any electronics laboratory will consider oscilloscope probes almost as "life' d" items that can be disposed of after a while when they are broken. Unfortunately the fact that they are clipped on to leads of equipment puts a tremendous strain on the mechanical clip arrangement. This is ultimately the part which breaks.

**X1 and X10 oscilloscope probes** There are two main types of passive voltage scope probes. They are normally designated X1 and X10, although 1X and 10X are sometimes seen. The designation refers to the factor by which the impedance of the scope itself is multiplied by the probe.

The X1 probes are suitable for many low frequency applications. They offer the same input impedance of the oscilloscope which is normally 1 M $\Omega$ . However for applications where better accuracy is needed and as frequencies start to rise, other test probes are needed. To enable better accuracy to be achieved higher levels

of impedance are required. To achieve this attenuators are built into the end of the probe that connects with the circuit under test. The most common type of probe with a built in attenuator gives an attenuation of ten, and it is known as a X10 oscilloscope probe.

The attenuation enables the impedance presented to the circuit under test to be increased by a factor of ten, and this enables more accurate measurements to be made. As the X10 probe attenuates the signal by a factor of ten, the signal entering the scope itself will be reduced. This has to be taken into account. Some oscilloscopes automatically adjust the scales according to the probe present, although not all are able to do this. It is worth checking before making a reading.

The 10X scope probe uses a series resistor (9 M Ohms) to provide a 10 : 1 attenuation when it is used with the 1 M Ohm input impedance of the scope itself. A 1 M Ohm impedance is the standard impedance used for oscilloscope inputs and therefore this enables scope probes to be interchanged between oscilloscopes of different manufacturers.

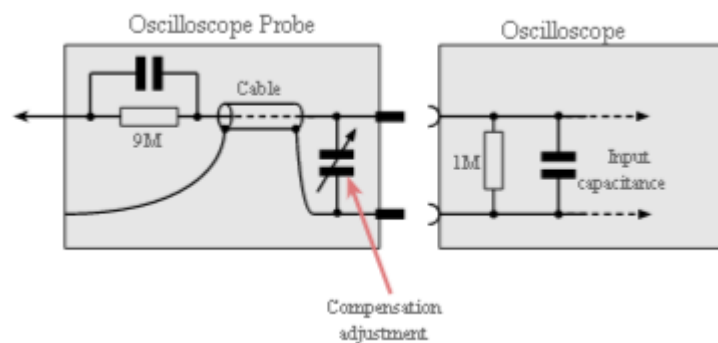

The scope probe circuit shown is a typical one that might be seen - other variants with the variable compensation capacitor at the tip are just as common. In addition to the X1 and X10 scope probes, X100 probes are also available. These oscilloscope probes tend to be used where very low levels of circuit loading are required, and where the high frequencies are present. The difficulty using the is the fact that the signal is attenuated by a factor of 100.

### **X10 oscilloscope probe compensation**

The X10 scope probe is effectively an attenuator and this enables it to load the circuit under test far less. It does this by decreasing the resistive and capacitive loading on the circuit. It also has a much higher bandwidth than a traditional X1 scope probe. The x10 scope probe achieve a better high frequency response than a normal X1 probe for a variety of reasons. It does this by decreasing the resistive and capacitive loading on the The X10 probe can often be adjusted, or compensated, to improve the frequency response.

### **Typical oscilloscope probe**

---

For many scope probes there is a single adjustment to provide the probe compensation, although there can be two on some probes, one for the LF compensation and the other for the HF compensation. Probes that have only one adjustment, it is the LF compensation that is adjusted, sometimes the HF compensation may be adjusted in the factory.

To achieve the correct compensation the probe is connected to a square wave generator in the scope and the compensation trimmer is adjusted for the required response - a square wave.

Compensation adjustment waveforms for X10 oscilloscope probe.

As can be seen, the adjustment is quite obvious and it is quick and easy to undertake. It should be done each time the probe is moved from one input to another, or one scope to another. It does not hurt to check it from time to time, even if it remains on the same input. As in most laboratories, things get borrowed and a different probe may be returned, etc . .

A note of caution: many oscilloscope probes include a X1/X10 switch. This is convenient, but it must be understood that the resistive and capacitive load on the circuit increase significantly in the X1 position. It should also be remembered that the compensation capacitor has no effect when used in this position.

As an example of the type of loading levels presented, a typical scope probe may present a load resistance of 10M $\Omega$  along with a load capacitance of 15pF to the circuit in the X10 position. For the X1 position the probe may have a capacitance of possibly 50pF plus the scope input capacitance. This may end up being of the order of 70 to 80pF.

### **Other types of probe**

Apart from the standard 1X and 10X voltage probes a number of other types of scope probe are available.

- **Current probes:** It is sometimes necessary to measure current waveforms on an oscilloscope. This can be achieved using a current probe. This has a probe that clips around the wire and enables the current to be sensed. Sometimes using the maths functions on a scope along with a voltage measurement on another channel it is possible to measure power,
- **Active probes:** As frequencies rise, the standard passive probes become less effective. The effect of the capacitance rises and the bandwidth is limited. To overcome these difficulties active probes can be used. They have an amplifier right at the tip of the probe enabling measurements with very low levels of capacitance to be made. Frequencies of several GHz are achievable using active scope probes.
- **Differential scope probes:** In some instances it may be necessary to measure differential signals. Low level audio, disk drive signals and many more instances use differential signals and these need to be measured as such. One way of achieving this is to probe both lines of the differential signal



---

using one probe each line as if there were two single ended signals, and then using the oscilloscope to add them differentially (i.e. subtract one from the other) to provide the difference.

Using two scope probes in this way can give rise to a number of problems. The main one is that single ended measurements of this nature do not give the required rejection of any common mode signals (i.e. Common Mode Rejection Ratio, CMMR) and additional noise is likely to be present. There may be a different cable length on each probe that may lead to a time difference and a slight skewing between the signals.

To overcome this a differential probe may be used. This uses a differential amplifier at the probing point to provide the required differential signal that is then passed along the scope probe lead to the oscilloscope itself. This approach provides a far higher level of performance.

- **High voltage probes:** Most standard oscilloscope voltage probes like the X1 or X10 are only specified for operation up to voltages of a few hundred volts at most. For operation higher than this a proper high voltage probe with specially insulated probe is required. It also will step down the voltage for the input to the scope so that the test instrument is not damaged by the high voltage. Often voltage probes may be X50 or X100.

### Special probing fixtures

Typical probes with 10 pf inputs and one 3|| to 6|| ground wire are not good enough for anything with faster than 2ns rising edges.

Three possible techniques to attack this problem

- Shop built 21:1 probe
- Fixtures for a low-inductance ground loop
- Embedded Fixtures for probing
- Total impedance =  $1K + 50 \text{ ohms}$ ; if the scope is set to  $50 \text{ mv / division}$ , the measured value is  $= 50 * (1050/50) = 1.05 \text{ V/division}$ .



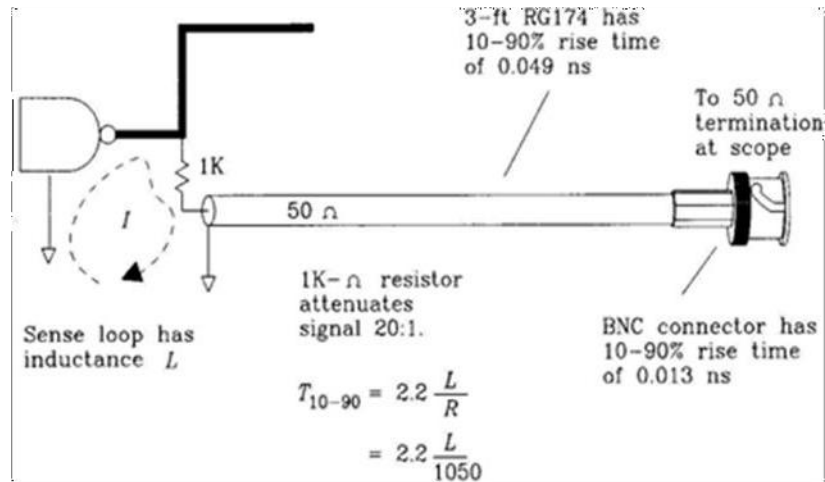

### Spurious signal pickup from probe ground loops

Mutual inductance between Signal loop A and Loop B

where

- $A_1$  ( $A_2$ ) = areas of loops
- $r$  = separation of loops
- Refer to figure for values.
- In this example,  $L_M = 0.17\text{nH}$
- Typically IC outputs
  - $\max \text{d}l/\text{d}t = 7.0 * 10^7 \text{ A/s}$

### How probes load down a circuit

- Common experience: Circuit works when probe is inserted. It fails when probe is removed.
- Effect is due to loading effect, impedance of the circuit has changed. The frequency response of the circuit will change as a result.
- To minimize the effect, the probe should have no more than 10% effect on the circuit under test.
  - E.g. the probe impedance must be 10 times higher than the source impedance of the circuit under test.

---

### **Advantages of the 21:1 probe**

- High input impedance = 1050 ohm
- Shunt capacitance of a 0.25 W 1K resistor is around 0.5 pf, that is small enough.
- But when the frequency is really high, this shunt capacitance may create extra loading to the signal source.
- Very fast rise time, the signal source is equivalent to connecting to a 1K load, the L/R rise time degradation is much smaller than connecting the signal to a standard 10 pf probe.

### **Oscilloscope probe specifications**

List of some of the more important oscilloscope probe specifications which are detailed below:

- Accuracy: The accuracy of any oscilloscope probe is of great importance. Typically for voltage sensing probes the accuracy refers to the attenuation of the signal by the probe as in the case of a 10X probe.
- Attenuation: This scope probe specification details the ratio of the output signal to the input signal in terms of voltage. A x10 probe will give ten times the input impedance but 1/10 of the voltage. Sometimes probes may be switchable between 1X and 10X.
- Bandwidth: The maximum bandwidth is the frequency at which the response falls by 3dB (i.e. -3dB) of the low frequency value
- Cable length: It is necessary to consider the length of the cable. The longer the cable, often the lower the bandwidth.
- Common mode rejection ratio, CMMR: It is a measure of the ability of the probe to reject any signals that are common to both inputs.
- Input capacitance: This is the typical input capacitance of the probe. It will depend to some degree on the capacitance of the scope.
- Input resistance: This is the system input resistance, i.e. the sum of any resistor in the probe (9 M Ohm for a 10X probe), plus the scope input resistance (typically 1 M Ohm).
- Input voltage: A maximum input voltage is specified. This is the highest voltage that the probe should be connected to. It will include both DC and AC components.
- Rise time: This is the time required for the leading edge of a pulse to rise from 10% to 90% of its final value

- 
- Tip or head style: Details of the scope probe tip or head style may also be given. Typically the clip will have a curved end that will clamp into the wire or test point.

---

## **UNIT-III (CIE-I)**

### **SIGNAL GENERATORS**

#### **INTRODUCTION TO STANDARD SIGNAL GENERATOR:-**

A standard signal generator produces known and controllable voltages. It is used as power source for the measurement of gain, signal to noise ratio (SN), bandwidth standing wave ratio and other properties. It is extensively used in the measuring of radio receivers and transmitter instrument is provided with a means of modulating the carrier frequency, which is indicated by the dial setting on the front panel.

The modulation is indicated by a meter. The output signal can be Amplitude Modulated (AM) or Frequency Modulated (FM). Modulation may be done by a sine wave, Square, rectangular, or a pulse wave.

The elements of a conventional signal generator:

- 1) RF Oscillator
- (2) Wide band amplifier.
- (3) External Oscillator.
- 4) Modulation Oscillator s
- (5) Output attenuator.

The carrier frequency is generated by a very stable RF oscillator using an LC tank circuit, having a constant output over any frequency range. The frequency of oscillations is indicated by the frequency range control and the venire dial setting. AM is provided by an internal sine wave generator or from an external source.

The signal generator is called an oscillator. A Wien bridge oscillator is used in this generator. The Wien bridge oscillator is the best of the audio frequency range. The frequency of oscillations can be changed by varying the capacitance in the oscillator. The frequency can also be changed in steps by switching the resistors of different values. The output of the Wien bridge oscillator goes to the function switch. The function switch directs the oscillator output either to the sine wave amplifier or to the square wave shaper. At the output, we get either a square or sine wave. The output is varied by means of an attenuator.

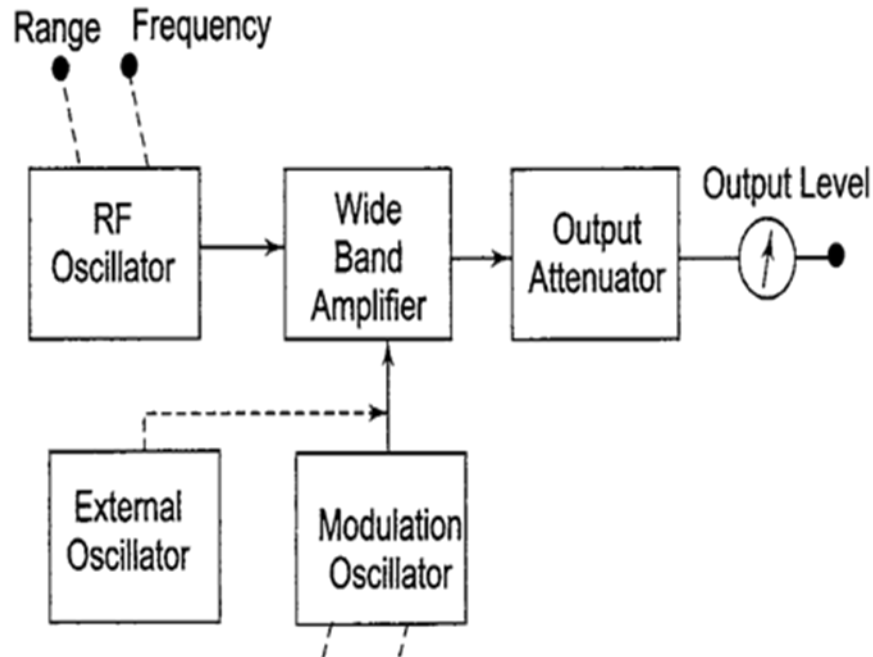

The instrument generates a frequency ranging from 10 Hz to 1 MHz continuously vV (rms). The output is taken through a push-pull amplifier. For low output, the impedance is 6000. The square wave amplitudes can be varied from 0 - 20 v (peak). It is possible to adjust the symmetry of the square wave from 30 - 70%. The instrument requires only 7W of power at 220V 50Hz.

The front panel of a signal generator consists of the following.

1. Frequency selector: It selects the frequency in different ranges and varies it continuously in a ratio of 1:11.  
The scale is non-linear.
2. Frequency multiplier: It selects the frequency range over 5 decades from 10 Hz to 7 MHz
3. Amplitude multiplier: It attenuates the sine wave in 3 decades, x 1 x 0.1 and x 0.01.
4. Variable amplitude: It attenuates the sine wave amplitude continuously
5. Symmetry control: It varies the symmetry of the square wave from 30% to 70%.
6. Amplitude: It attenuates the square wave output continuously.
7. Function switch: It selects either sine wave or square output.
8. Output available: This provides sine wave or square wave output.
9. Sync: This terminal is used to provide synchronization of the internal signal with an external signal.

---

## 10. On-Off Switch

### **SQUARE AND PULSE GENERATOR:-**

These generators are used as measuring devices in combination with a CRO. They provide both quantitative and qualitative information of the system under test. They are made use of in transient response testing of amplifiers. The fundamental difference between a pulse generator and a square wave generator is in the duty cycle.

Duty cycle = A square wave generator has a 50% duty cycle.

### **Requirements of a Pulse**

1. The pulse should have minimum distortion, so that any distortion, in the display is solely due to the circuit under test.
2. The basic characteristics of the pulse are rise time, overshoot, ringing, sag, and undershoot.
3. The pulse should have sufficient maximum amplitude, if appreciable output power is required by the test circuit, e.g. for magnetic core memory. At the same time, the attenuation range should be adequate to produce small amplitude pulses to prevent over driving of some test circuit.
4. The range of frequency control of the pulse repetition rate (PRR) should meet the needs of the experiment. For example, a repetition frequency of 100 MHz is required for testing fast circuits. Other generators have a pulse-burst feature which allows a train of pulses rather than a continuous output.
5. Some pulse generators can be triggered by an externally applied trigger signal; conversely, pulse generators can be used to produce trigger signals, when this output is passed through a differentiator circuit.
6. The output impedance of the pulse generator is another important consideration. In a fast pulse system, the generator should be matched to the cable and the cable to the test circuit. A mismatch would cause energy to be reflected back to the generator by the test circuit, and this may be reflected by the generator, causing distortion of the pulses.
7. DC coupling of the output circuit is needed, when dc bias level is to be maintained. The basic circuit for pulse generation is the asymmetrical multi-vibrator.

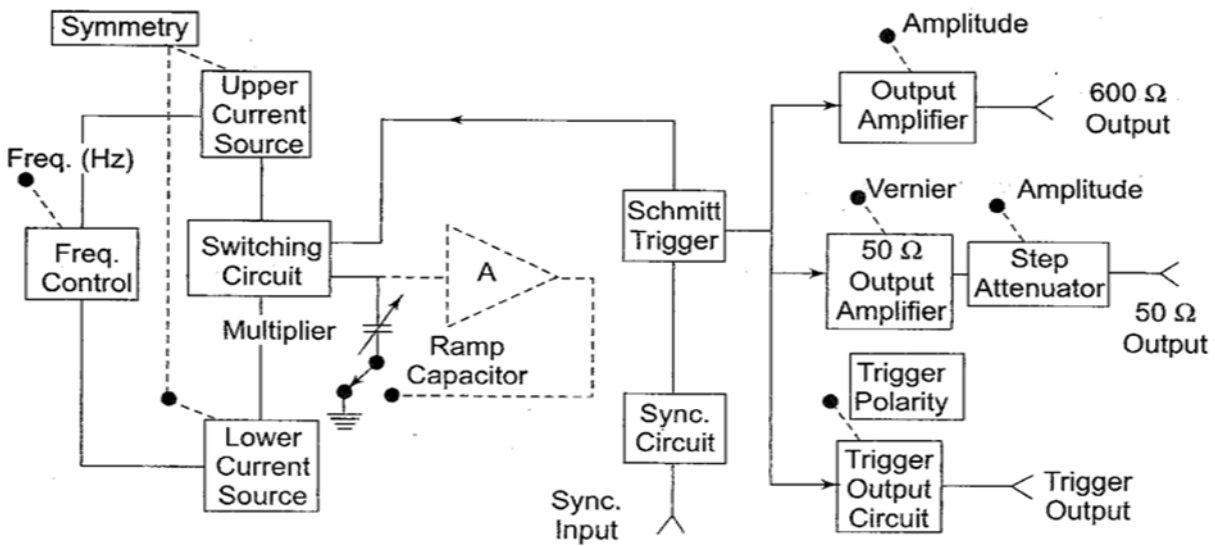

A laboratory type square wave and pulse generator is shown in Fig 6.1

The frequency range of the instrument is covered in seven decade steps from 1Hz to 10 MHz, with a linearly calibrated dial for continuous adjustment on all ranges. The duty cycle can be varied from 25 - 75%. Two independent outputs are available, a 50Ω source that supplies pulses with a rise and fall time of 5 ns at 5V peak amplitude and a 600Ω source which supplies pulses with a rise and fall time of 70 ns at 30 V peak amplitude. The instrument can be operated as a free running generator or, it can be synchronized with external signals.

The basic generating loop consists of the current sources, the ramp capacitor, the Schmitt trigger and the current switching circuit as shown in the fig

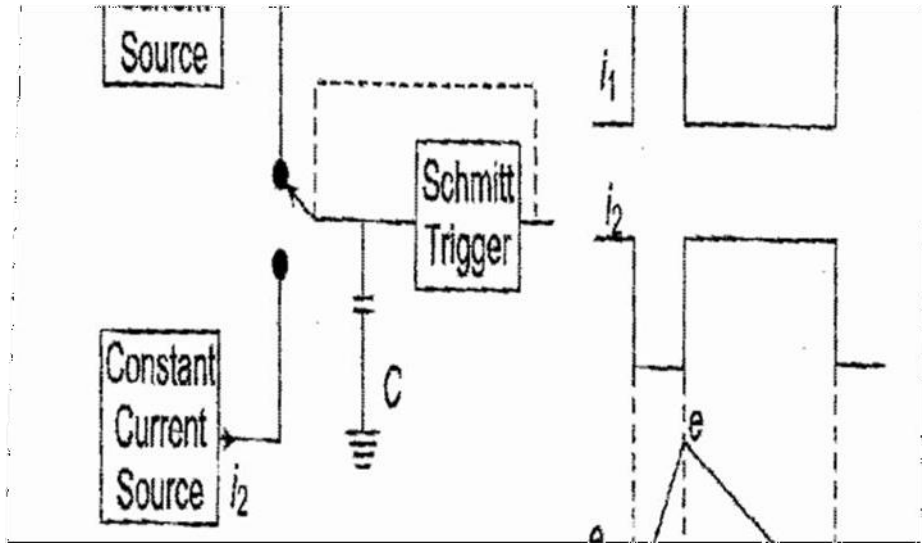

The upper current source supplies a constant current to the capacitor and the capacitor voltage increases linearly. When the positive slope of the ramp voltage reaches the upper limit set by the internal circuit components, the Schmitt trigger changes state. The trigger circuit output becomes negative and reverses the condition of the current switch. The capacitor discharges linearly, controlled by the lower current source.

When the negative ramp reaches a predetermined lower level, the Schmitt trigger switches back to its original state. The entire process is then repeated.

The ratio  $i_1/i_2$  determines the duty cycle, and is controlled by symmetry control. The sum of  $i_1$  and  $i_2$  determines the frequency. The size of the capacitor is selected by the multiplier switch. The unit is powered by an internal supply that provides regulated voltages for all stages of the instrument.

### **The precautionary measures to be taken in a signal generator application:-**

A signal generator is an instrument, which can produce various types of wave forms such as sine wave, square wave, triangular wave, saw tooth wave, pulse trains etc. As it can generate a variety of waveforms it is widely used in applications like electronic troubleshooting and development, testing the performance of electronic equipments etc. In such applications a signal generator is used to provide known test conditions (i.e., desired signals of known amplitude and frequency).

Hence, the following precautionary measures should be taken while using a signal generator for an application.



- 
1. The amplitude and frequency of the output of the signal generator should be made stable and well known.
  2. There should be provision for controlling the amplitude of signal generator output from very small to relatively large values.
  3. The output signal of generator should not contain any distortion and thus, it should possess very low harmonic contents.
  4. Also, the output of the signal generator should be less spurious.

### **FUNCTION GENERATOR:**

A function generator produces different waveforms of adjustable frequency. The common output waveforms are the sine, square, triangular and saw tooth waves. The frequency may be adjusted, from a fraction of a Hertz to several hundred kHz. Various outputs of the generator can be made available at the same time. For example, the generator can provide a square wave to test the linearity of a rectifier and simultaneously provide a saw tooth to drive the horizontal deflection amplifier of the CRO to provide a visual display.

Capability of Phase Lock the function generator can be phase locked to an external source. One function generator can be used to lock a second function generator, and the two output signals can be displaced in phase by adjustable amount. In addition, the fundamental frequency of one generator can be phase locked to a harmonic of another generator, by adjusting the amplitude and phase of the harmonic; almost any waveform can be generated by addition. The function generator can also be phase locked to a frequency standard and its output waveforms will then have the same accuracy and stability as the standard source.

The block diagram of a function generator:

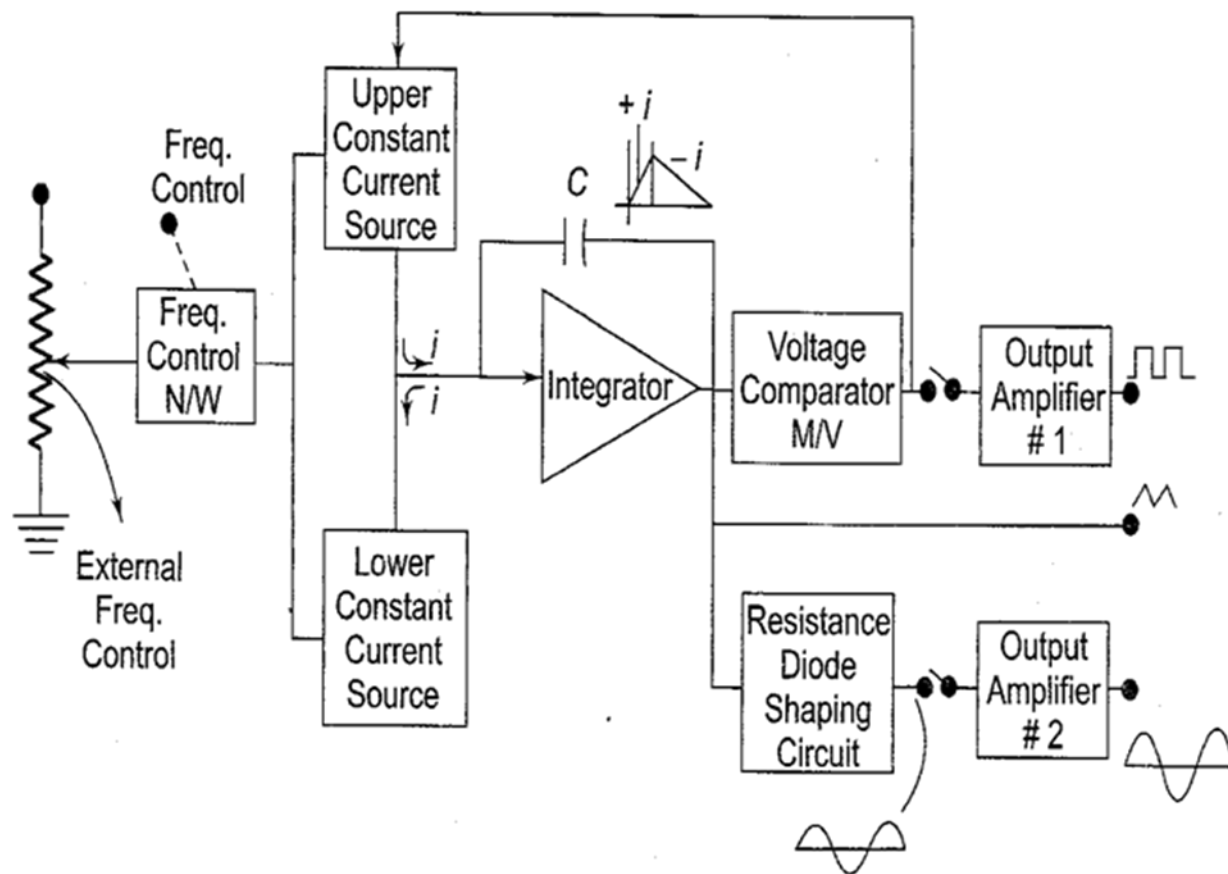

The block diagram of a function generator is illustrated in fig. Usually the frequency is controlled by varying the capacitor in the LC or RC circuit. In the instrument the frequency is controlled by varying the magnitude of current which drives the integrator. The instrument produces sine, triangular and square waves with a frequency range of 0.01 Hz to 100 kHz.

The frequency controlled voltage regulates two current sources. The upper current source supplies constant current to the integrator whose output voltage increases linearly with time, according to the equation of the output signal voltage. An increase or decrease in the current increases or decreases the slope of the output voltage and hence controls the frequency. The voltage comparator multi-vibrator changes states at a pre-determined maximum level of the integrator output voltage. This change cuts off the upper current supply and switches on the lower current supply. The lower current source supplies a reverse current to the integrator, so that its output decreases linearly with time. When the output reaches a pre-determined Minimum level, the voltage comparator again changes state and switches on the Lower current source. The output of the integrator is a triangular waveform whose frequency is determined by the magnitude of the current supplied by the constant current sources. The comparator output delivers a square wave voltage of the same frequency.

---

$$e = - 1/C \int idt$$

The resistance diode network alters the slope of the triangular wave as its amplitude changes and produces a sine wave with less than 1% distortion.

### **SWEEP GENERATOR:**

It provides a sinusoidal output voltage whose frequency varies smoothly and continuously over an entire frequency band, usually at an audio rate. The process of frequency modulation may be accomplished electronically or mechanically. It is done electronically by using the modulating voltage to vary the reactance of the oscillator tank circuit component, and mechanically by means of a motor driven capacitor, as provided for in a modern laboratory type signal generator. Figure shows a basic block diagram of a sweep generator. The frequency sweeper provides a variable modulating voltage which causes the capacitance of the master oscillator to vary. A representative sweep rate could be of the order of 20 sweeps /second. A manual control allows independent adjustment of the oscillator resonant frequency. The frequency sweeper provides a varying sweep voltage synchronization to drive the horizontal deflection plates of the CRO. Thus the amplitude of the response of a test device will be locked and displayed on the screen.

To identify a frequency interval, a marker generator provides half sinusoidal waveforms at any frequency within the sweep range. The marker voltage can be added to the sweep voltage of the CRO during alternate cycles of the sweep voltage, and appears superimposed on the response curve.

The automatic level control circuit is a closed loop feedback system which monitors the RF level at some point in the measurement system. This circuit holds the power delivered to the load or test circuit constant and independent of frequency and impedance changes. A constant power level prevents any source mismatch and also provides a constant readout calibration with frequency.

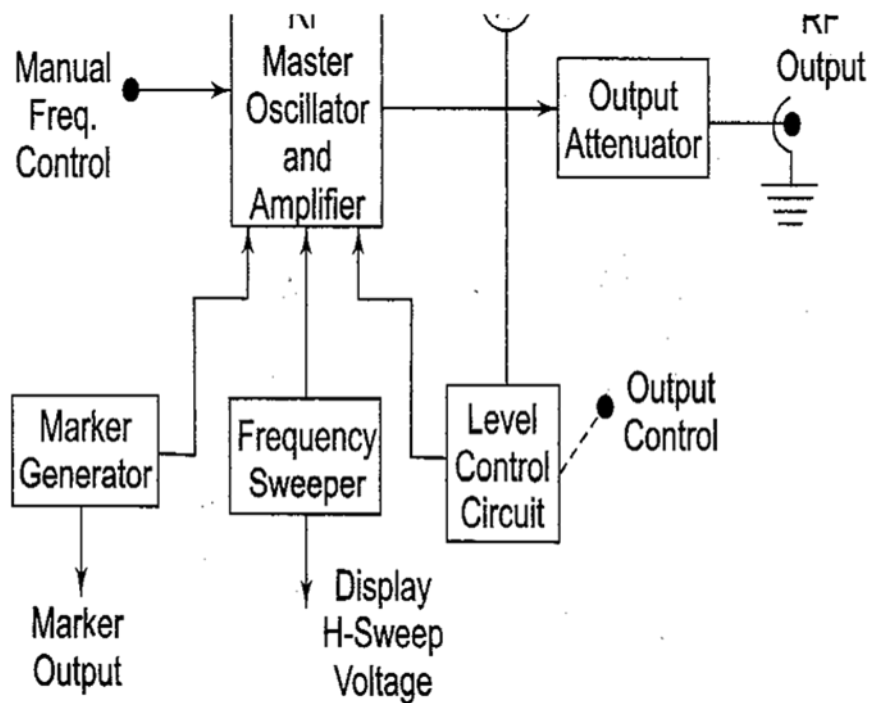

### **SWEEP FREQUENCY GENERATOR:**

Sweep frequency generator is a type of signal generator that is used to generate a sinusoidal output. Such an output will have its frequency automatically varied or swept between two selected frequencies. One complete cycle of the frequency variation is called a sweep depending on the design of a particular instrument; either linear or logarithmic variations can be introduced to the frequency rate. However, over the entire frequency range of the sweep, the amplitude of the signal output is designed to remain constant.

Sweep-frequency generators are primarily used for measuring the responses of amplifiers, filters, and electrical components over various frequency bands. The frequency range of a sweep-frequency generator usually extends over three bands, 0.001 Hz – 100 kHz (low frequency to audio), 100 kHz – 1,500 MHz (RF range), and 1-200 GHz (microwave range). It is really a hectic task to know the performance of measurement of bandwidth over a wide frequency range with a manually tuned oscillator. By using a sweep-frequency generator, a sinusoidal signal that is automatically swept between two chosen frequencies can be applied to the circuit under test and its response against frequency can be displayed on an oscilloscope or X-Y recorder.

Thus the measurement time and effort is considerably reduced. Sweep generators may also be employed for checking and repairing of amplifiers used in TV and radar receivers.

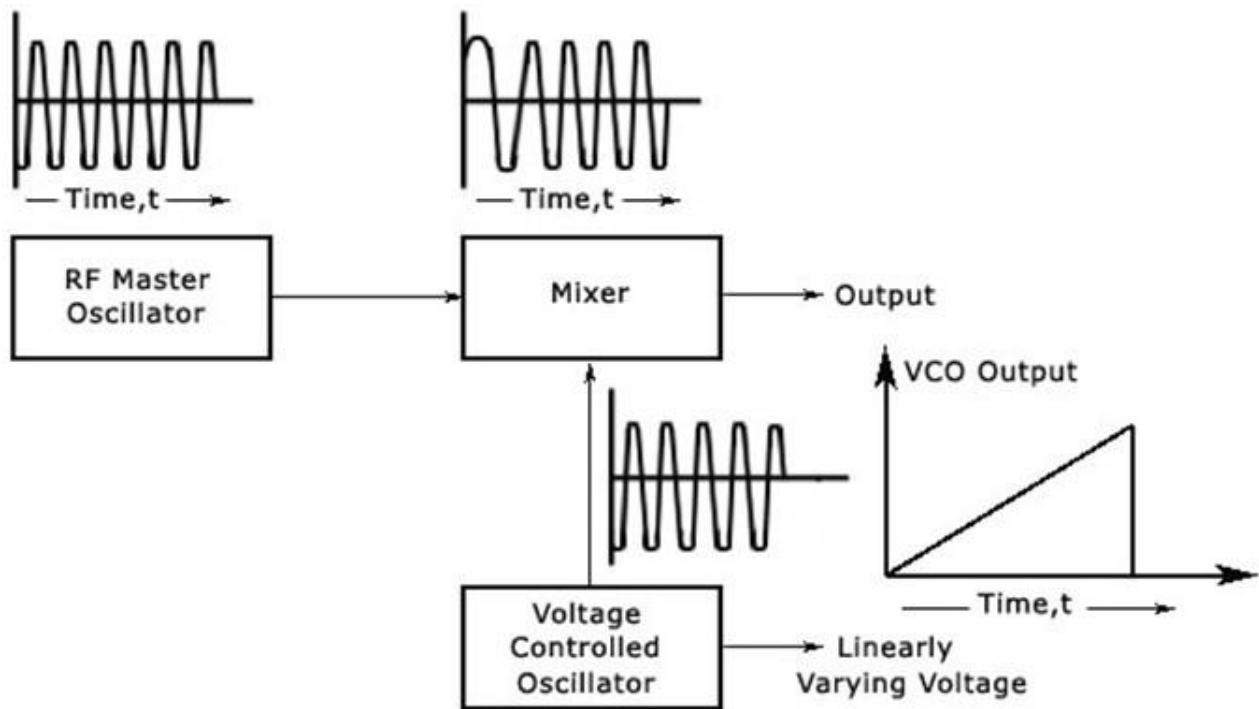

The most important component of a sweep-frequency generator is the master oscillator. It is mostly an RF type and has many Operating ranges which are selected by a range switch. Either mechanical or electronic variations can be brought to the frequency of the output signal of the signal generator.

### Arbitrary Waveform Generator, AWG

The waveforms produced by arbitrary waveform generators, AWGs can be either repetitive or sometimes just a single-shot. If the AWG waveform is only a single shot, then a triggering mechanism is needed to trigger the AWG and possibly the measuring instrument. The AWG is able to generate an arbitrary waveform defined by a set of values, i.e. "waypoints" entered to set the value of the waveform at specific times. They can make up a digital or even an analogue waveform. As a result an arbitrary waveform generator is a form of test equipment that is able to produce virtually any wave shape that is required.

### Arbitrary Waveform Generator techniques

There are a number of ways of designing arbitrary waveform generators. They are based around digital techniques, and their design falls into one of two main categories:

- Direct Digital Synthesis, DDS: This type of arbitrary waveform generator is based around the DDS types of frequency synthesizer, and sometimes it may be referred to as an Arbitrary Function Generator, AFG.

- Variable-clock arbitrary waveform generator: The variable clock arbitrary function generator is the more flexible form of arbitrary waveform generator. These arbitrary waveform generators are generally more flexible, although they do have some limitations not possessed by the DDS versions. Sometimes these generators are referred to as just arbitrary waveform Generators, AWGs rather than arbitrary function generators.
- Combined arbitrary waveform generator: This format of AWG combines both of the other forms including the DDS and variable clock techniques. In this way the advantages of both systems can be realized within a single item of test equipment.

### Arbitrary function generator basics:

As mentioned, this type of arbitrary waveform generator is based around the DDS types of frequency synthesizer, and sometimes it may be referred to as an Arbitrary Function generator, AFG.

The arbitrary function generator uses integrated circuits intended for direct digital frequency synthesizers, but enables an arbitrary waveform generator circuit to be created relatively easily and for an economic price. To look at how an arbitrary function generator works, it is necessary to look at the operation of a direct digital synthesizer. This circuit operates by storing the points of a waveform in digital format, and then recalling them to generate the waveform. These points can be on any form of repetitive waveform that is required. The rate at which the DDS completes one waveform governs the frequency. The basic block diagram of the DDS based arbitrary waveform generator is shown below.

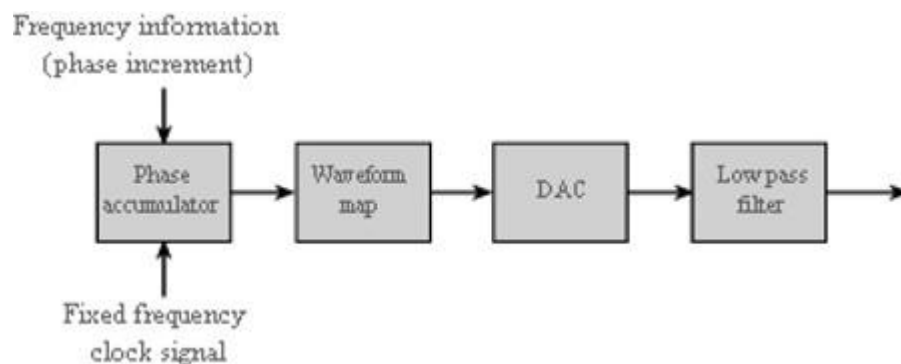

The operation of the DDS within the arbitrary function generator can be envisaged by looking at the way that phase progresses over the course of one cycle of the waveform. The phase is often depicted as a line of phasor rotating around a circle. As the phase advances around the circle, this corresponds to advances in the waveform. The faster it progresses, the sooner it completes a cycle and hence the higher the frequency.

---

The direct digital synthesizer operates by storing various points of the required waveform in digital format in a memory. These can then be recalled to generate the waveform as they are required. To simulate the phase advances a phase accumulator is used. This takes in phase increment information, and clock pulses from a clock. For each clock pulse, the phase will advance a certain amount. The greater the increment, the larger the phase advance, and hence the higher the frequency generated.

At each clock pulse the phase information is presented to the memory and the relevant location is accessed, providing the waveform information for that particular phase angle. It can be seen that any waveform can be loaded into the memory; although a sine wave is shown on the diagram, the actual waveform could be anything. While it is possible to load certain preset waveforms into the memory, it is also possible to load user generated ones in as well. These make the test instrument an arbitrary waveform generator or arbitrary function generator rather than a standard function generator.

### **Advantages and disadvantages of AFG:**

While the arbitrary function generator or DDS based version of the arbitrary waveform generator, has many advantages, there are also some disadvantages that should also be taken into account when choosing what type of signal generator to use.

#### **Arbitrary function generator advantages**

- **Sub Hz frequency resolution:** By using a long word length phase accumulator in the phase accumulator of the DDS, it is possible to achieve sub-Hertz frequency resolution levels.
- **Down sampling:** Waveforms are automatically truncated by sampling to allow repetition rates above the clock frequency.
- **Digital modulation:** It is possible to add digital modulation words to the phase accumulator to provide a means of providing digital modulation.

#### **Arbitrary function generator disadvantages**

- **Waveform jitter:** Waveform jitter is an issue with arbitrary function generators because frequencies are up-sampled or down-sampled and this results in missing samples and hence jitter. Only frequencies equal to the clock frequency divided by the waveform length and its sub multiples are not sampled and therefore they do not suffer from this problem



- **Single waveform capability:** It is only possible to generate a single waveform at a time because memory segmentation and waveform sequencing is not possible using a DDS arbitrary function generator.

A pattern generator provides video signals directly, and with RF modulation, on standard TV channels for alignment, testing and servicing of TV receivers. The output signal is designed to produce simple geometric patterns like vertical and horizontal bars, checkerboard, cross-hatch, dots, etc.

These patterns are used for linearity and video amplifier adjustment. In addition to this, an FM sound signal is also provided in pattern generators for aligning sound sections of the receiver.

A simplified functional block diagram of a pattern cum sound signal generator is shown in Fig

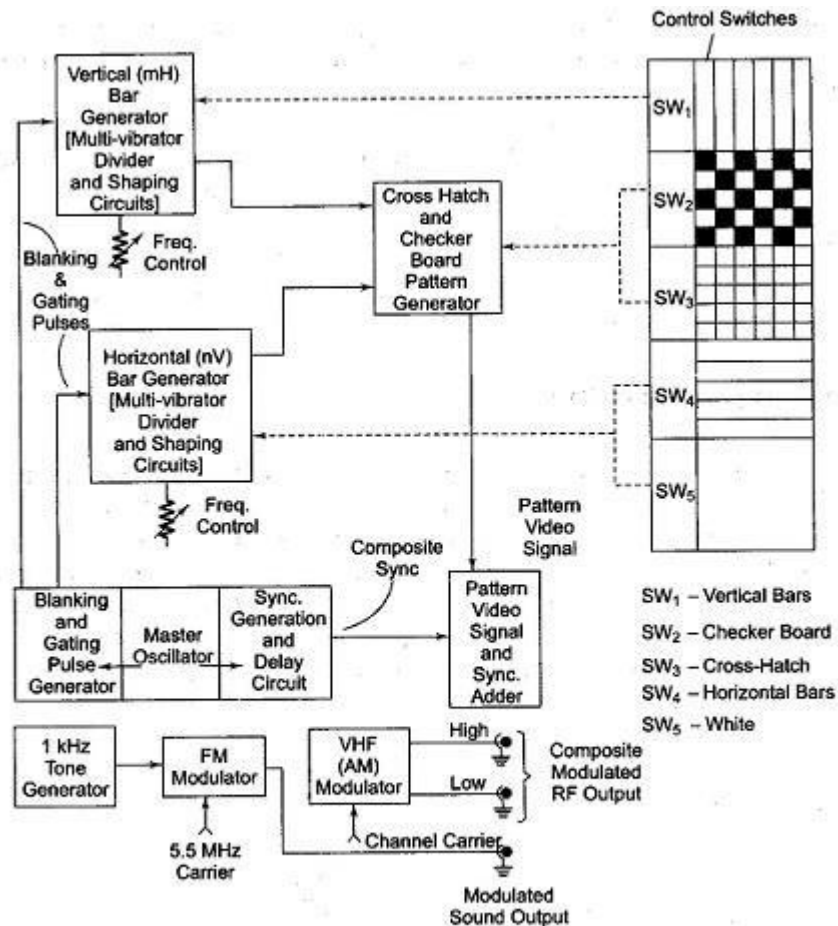

**Fig. 8.14** Simplified Functional Block Diagram of a Pattern Cum Sound Signal Generator

The generator employs two stable chains of multivibrators, dividers and pulse shaping circuits, one below the line frequency to produce a series of horizontal bars, and another above 15625 Hz to produce vertical



---

bars. The signals are modified into short duration pulses, which when fed to the video section of the receiver along with the sync pulse train, produce fine lines on the screen.

Multivibrators produce a square wave video signal at  $m$  times the horizontal frequency to provide  $m$  vertical black and white bars. After every  $m$  cycles, the horizontal blanking pulse triggers the multivibrators for synchronising the bar signal on every line. A control on the front panel of the Video Pattern Generator enables variation of multivibrators frequency to change the number of bars.

Similarly, square wave pulses derived either from 50 Hz mains or from the master oscillator are used to trigger another set of multivibrator to generate square wave video signals that are  $n$  times the vertical frequency. On feeding the video amplifier these produce horizontal black and white bars. The number of horizontal bars can also be varied by a potentiometer that controls the switching rate of the corresponding multivibrator. (The bar pattern signal is combined with the sync and blanking pulses in the video adder to produce composite video signals before being fed to the modulator).

The provision of switches in the signal path of the two multivibrators enables the generation of various patterns. If both mH and nV switches are off, a blank white raster is produced. With only the mH switch on, vertical bars are produced, and with only the nV switch on, horizontal bars are generated. With both switches on, a cross-hatch pattern will be produced (Fig. 8.14).

The horizontal bar pattern is used for checking vertical linearity. These bars should be equally spaced throughout the screen for linearity. Similarly, the vertical bar pattern can be used for checking and setting horizontal linearity. With the cross-hatch pattern formed by the vertical and horizontal lines, linearity can be adjusted more precisely, because any unequal spacing of the lines can be discerned.

Picture centering and aspect ratio can also be checked with the cross-hatch pattern by counting the number of squares on the vertical and horizontal sides of the screen.

The Video Test Pattern Generator can also be used for detecting any spurious oscillations in the sweep generation circuits, interaction between the two oscillators, poor interlacing, and barrel and pin cushion effects.

Modulated picture signals are available on limited channels for injecting into the RF section of the receiver.

Similarly, an FM sound signal with a carrier frequency of  $5.5 \text{ MHz} \pm 100 \text{ kHz}$ , modulated by a 1 kHz tone, is provided for aligning sound IF and discriminator circuits. A  $75/300 \Omega$  VHF balun is usually available as a standard accessory with the Video Test Pattern Generator.

## UNIT-III(CIE-II)

### SIGNAL ANALYZER

#### **Introduction:**

- Any complex waveform is made up of a fundamental frequency and its harmonics. It is often required to measure the amplitude of each harmonic and fundamental frequency individually. This can be done using instrument known as wave analyzer.
- Wave analyzers are also referred to as frequency selective voltmeter, carrier frequency voltmeter and selective level voltmeter.

The wave analyzers are tuned to the frequency of the component, whose amplitude is to be measured

#### **BASIC WAVE ANALYZER:**

- It consist of a primary detector, Which is a simple LC Circuit. This LC circuit is adjusted for resonance at the frequency of the particular harmonic component to be measured.

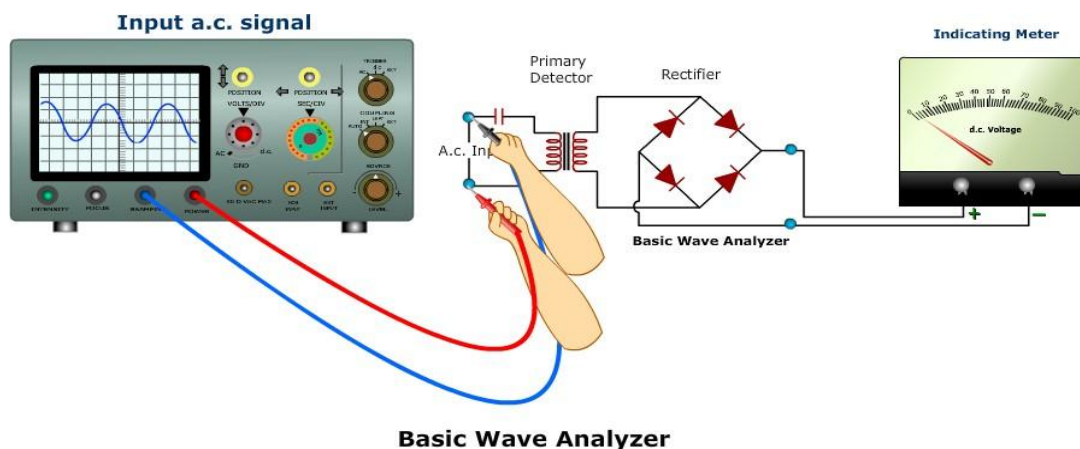

- The intermediate stage is a full wave rectifier, to obtain the average value of the input signal. The indicating device is a simple dc voltmeter that is calibrated to read the peak value of the sinusoidal input voltage.

- The LC circuit is tuned to a single frequency, it passes only frequency to which it is tuned and rejects all other frequencies
- A number of tuned filters, connected to the indicating device through a selector switch, would be required for a wave analyzer.

### **Frequency Selective Wave Analyzer:**

The Wave analyzer consists of a very narrow pass-band filter section which can be tuned to a particular frequency within the audible frequency range 20Hz-20KHz. The block diagram of a wave analyzer is as shown

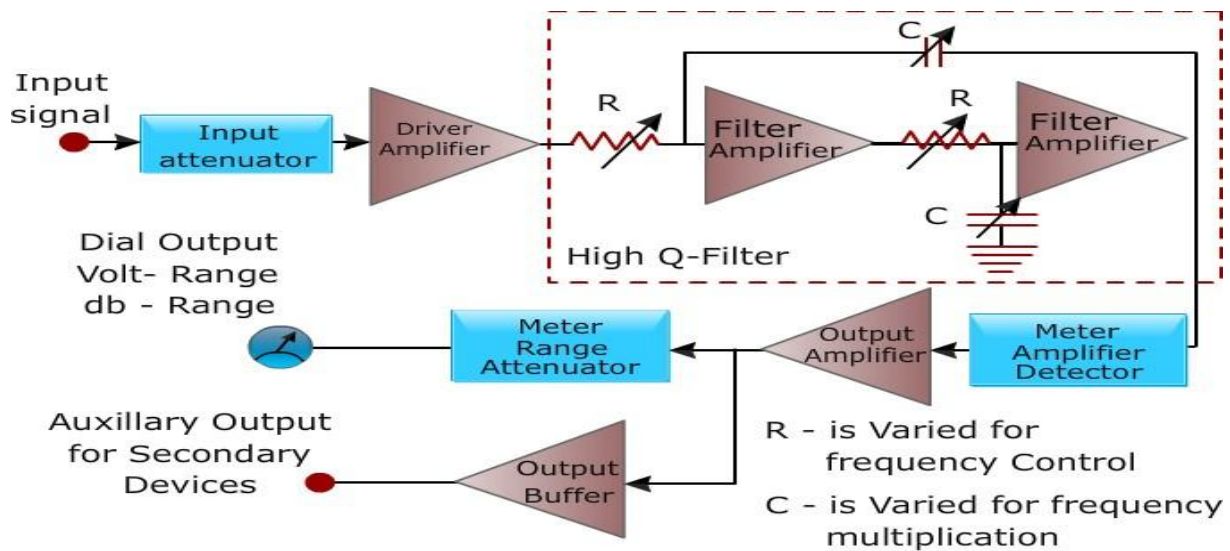

### **Frequency Selective Wave Analyzer**

- The complex wave to be analyzed is passed through an adjustable attenuator which serves as a range multiplier and permits a large range of signal amplitudes to be analyzed without loading the amplifier.
- The output of the amplifier is fed to a frequency selective amplifier, which amplifies the selected frequency. This driver amplifier applies the attenuated input signal to a high-Q active filter. This high Q-filter is a low pass filter which allows the frequency which is selected to pass and reject all others.
- The filter consist of a cascaded RC resonant circuit and amplifier. For selecting the frequency range, the capacitors generally use are of the closed tolerance polystyrene type and the resistances

used are precision potentiometers. The capacitors are used for range changing and the potentiometer is used to change the frequency within the selected pass-band.

- The selected output from the final amplifier stage is applied to the meter circuit and to an untuned buffer amplifier. The main function of amplifier is to drive output devices, such as recorders or counters.
- The wave analyzer must have extremely low input distortion, undetectable by the analyzer itself.

### **Heterodyne Wave Analyzer:**

- Simple Wave analyzers are useful for measurement in the audio frequency range only. Measurement in the RF range and above (MHz range), ordinary wave analyzers cannot be used. Hence, special types of wave analyzers working on the principle of heterodyning (mixing) are used. These wave analyzers are known as heterodyne wave analyzers.
- In these wave analyzers, the input signal to be analyzed is heterodyned with the signal from the internal tunable local oscillator in the mixer stage to produce a higher IF frequency.
- By tuning the local oscillator frequency, various signal frequency components can be shifted within the passband of the IF amplifier. The output of the IF amplifier is rectified and applied to the meter circuit.
- An instrument that involves the principle of heterodyning is the heterodyning tuned voltmeter, as shown in figure

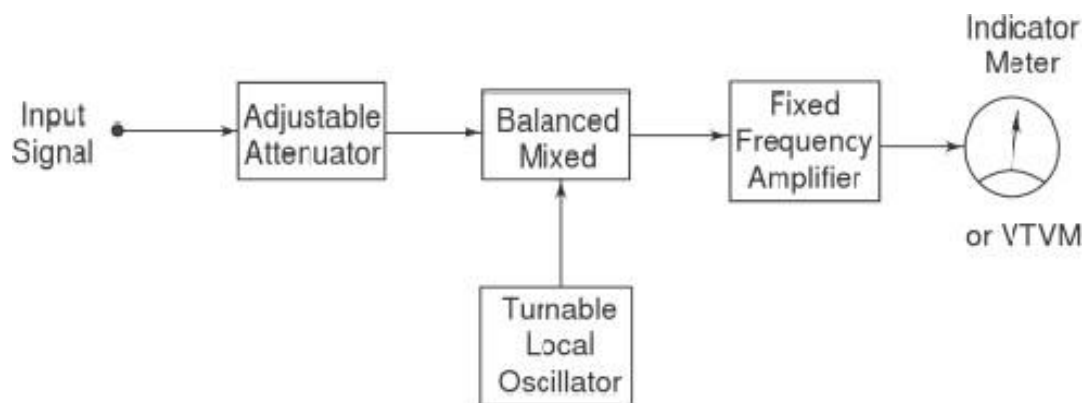

**Heterodyne wave analyzer**

The input signal is heterodyned to the known IF by means of a tunable local oscillator. The amplitude of the unknown component is indicated by the VTVM or output meter. The VTVM is calibrated by means of signals of known amplitude.

The frequency of the component is identified by the local oscillator frequency, i.e. the local oscillator frequency, i.e. the local oscillator frequency is varied so that all the components can be identified.

This analyzer has good frequency resolution and can measure the entire AF frequency range.

- In this two types of selective amplifiers find use in heterodyne wave analyzers. The first type employs a crystal filter, typically having a center frequency of 50KHz. By employing two crystals in a band-pass arrangement, it is possible to obtain a relatively flat pass band. Another type uses a resonant circuit in which effective Q has been made high and is controlled by negative feedback

A Modified heterodyne wave analyzer is shown. In this analyzer the attenuator provides the required input signal for heterodyning in the first mixer stage with the signal from a local oscillator having frequency of 30-48 MHz.

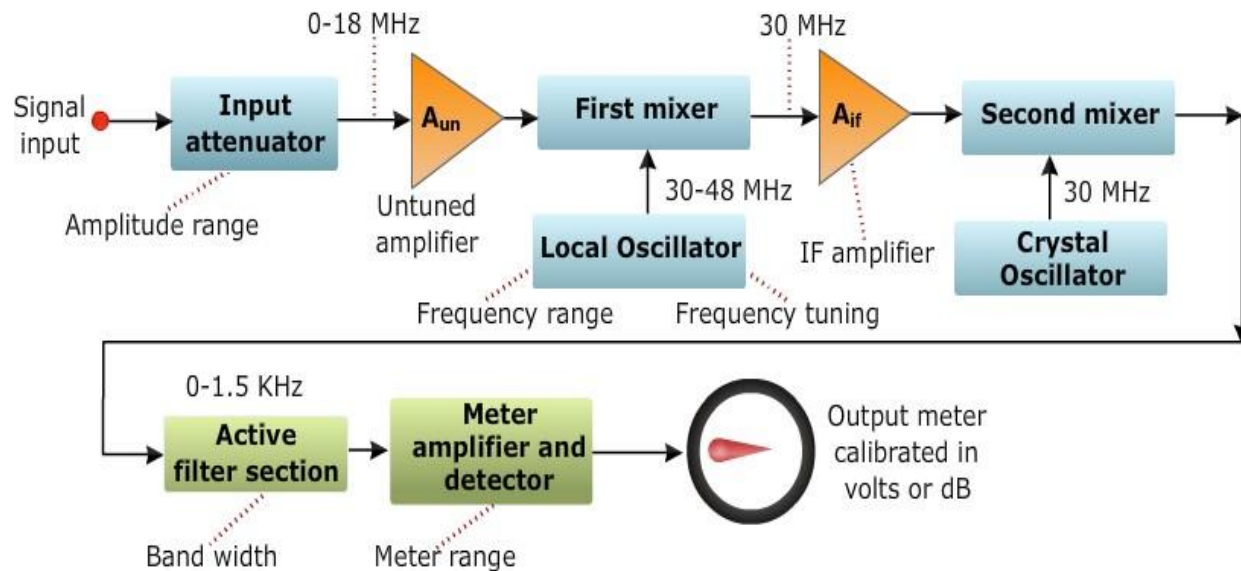

### Block Diagram of Heterodyne Wave Analyzer

- The first mixer stage produces an output which is the difference of the LO frequency and the input signal, to produce an IF signal of 30MHz.

- This IF frequency is uniformly amplified by the IF amplifier. This amplified IF signal is fed to the second mixer stage, where it is again heterodyned to produce a difference frequency.
- The selected component is then passed to the meter amplifier and detector circuit through an active filter having a controlled bandwidth.
- This wave analyzer is operated in the RF range of 10KHz-18MHz .
- 

### **Harmonic Distortion Analyzer:**

- A distortion analyzer measures the total harmonic power present in the test wave rather than the distortion caused by each component.
- The simplest method is to suppress the fundamental frequency by means of a high pass filter whose frequency is a little above the fundamental frequency. This high pass allows only the harmonics to pass and the total harmonic distortion can then be measured.

Other types of harmonic distortion analyzers based on fundamental suppression are as follows.

#### (a) Employing Resonance Bridge

- The bridge is balanced for fundamental frequency, i.e. L and C are tuned to the fundamental frequency. The bridge is unbalanced for the harmonics, i.e. only harmonic power will be available at the output terminal and can be measured.

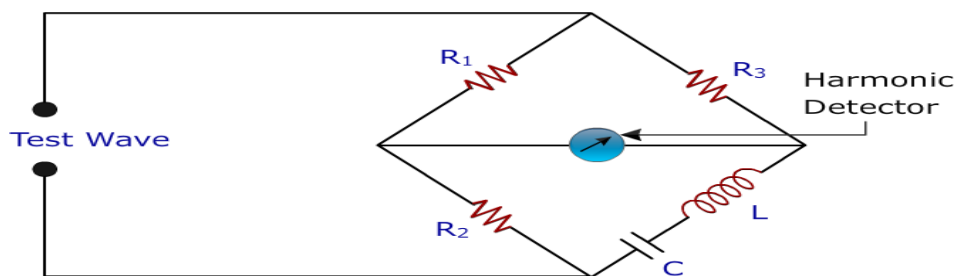

**Resonance Bridge**

- If the fundamental frequency is changed, the bridge must be balanced again. If L & C are fixed components, then this method is suitable only when the test wave has a fixed frequency. Indicators can be thermocouples or square law VTVM's. This indicates the RMS value of all harmonics.

- When a continuous adjustment of the fundamental frequency is desired, a Wien bridge arrangement is used.

b) Wien's Bridge Method:

- The bridge is balanced for the fundamental frequency. The fundamental energy is dissipated in the bridge circuit elements. Only the harmonic components reach the output

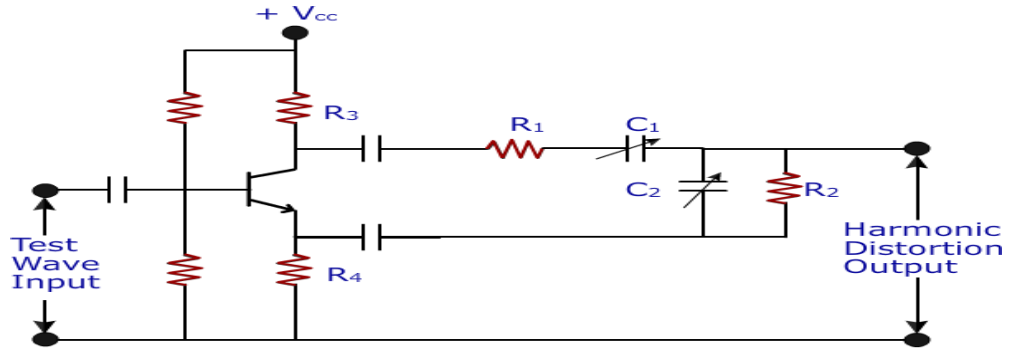

**Wien's Bridge Method**

terminals.

- The harmonic distortion output can then be measured with a meter. For balance at the fundamental frequency  $C_1=C_2=C$ ,  $R_1=R_2=R$ ,  $R_3=2R_4$ .

c) Bridged T-Network Method

From the figure L and C's are tuned to the fundamental frequency, and R is adjusted to bypass fundamental frequency.

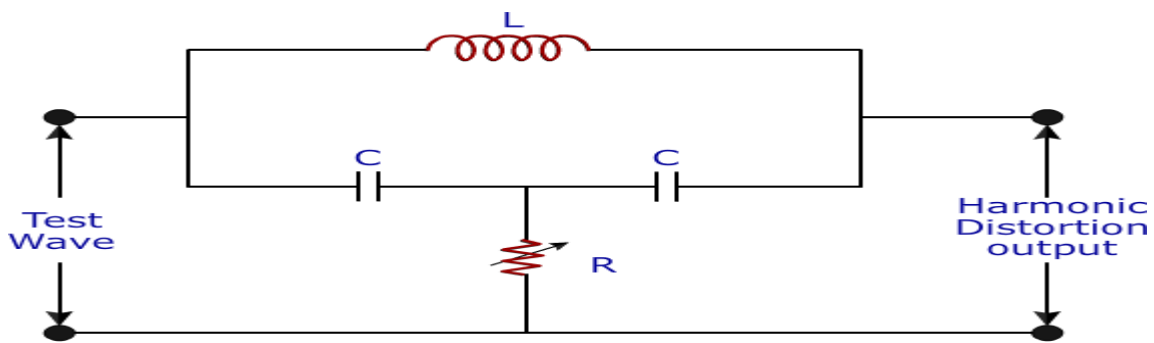

**Bridged T-Network Method**

The tank circuit being tuned to the fundamental frequency, the fundamental energy will circulate in the tank and is bypassed by the resistance. Only harmonic components will reach the output terminals and the distorted output can be measured by the meter. The Q of the resonant circuit must be at least 3-5.

- One way of using bridge T-N



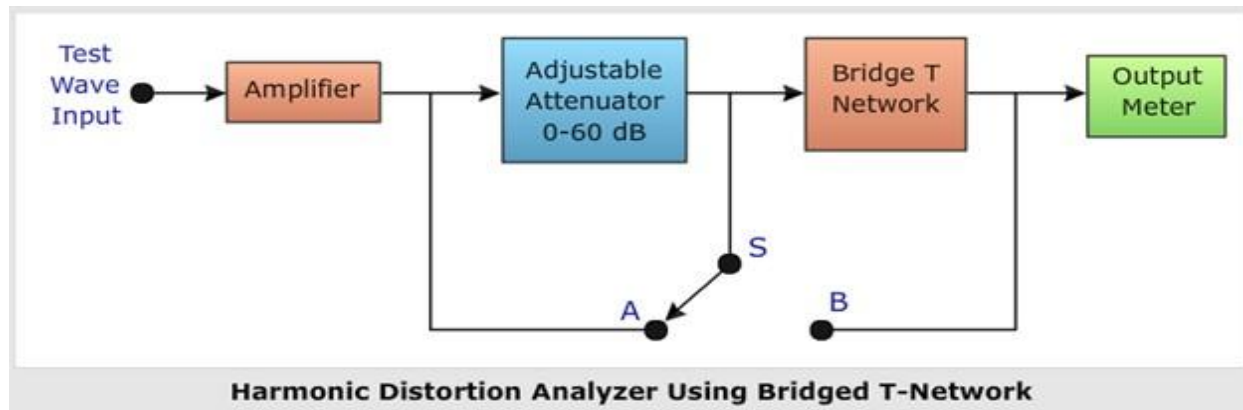

- From the figure, The switch S is first connected to point A so that the attenuator is excluded and the bridge T-network is adjusted for full suppression of the fundamental frequency, i.e. Minimum output indicates that the bridged T network is tuned to the fundamental frequency and that fundamental frequencies is fully suppressed.
- The switch is next connected to terminal B, i.e. the bridge T- network is excluded.
- Attenuation is adjusted until the same reading is obtained on the meter. The attenuator reading indicates the total rams distortion
- Distortion measurement can also be obtained by means of a wave analyzer, knowing the amplitude and the frequency of each component, the harmonic distortion can be calculated. However, distortion meters based on fundamental suppression are simpler to design and less expensive than wave analyzers.
- The disadvantage is that they give only the total distortion and not the amplitude of individual distortion components.

### **Spectrum Analyzer**

- Generally in observation of signal we use the time domain, In this with time as the X-axis(Amplitude of signal Vs time). Another way of observing signals i.e. frequency domain, in x-axis frequency and y-axis amplitude. The instrument providing this frequency domain view is the spectrum analyzer.
- A spectrum analyzer provides a calibrated graphical display on its CRT,with frequency on the horizontal axis and amplitude on the vertical axis.



- The height displayed represents the absolute magnitude and the horizontal location represents frequency.
- Spectrum analyzers provide a display of the frequency spectrum over a given frequency band. Spectrum analyzers use either a parallel filter bank or a swept frequency technique.
- In a parallel filter bank analyzer, the frequency range is covered by a series of filters whose central frequencies and bandwidth are so selected that they overlap each other, as shown above figure.

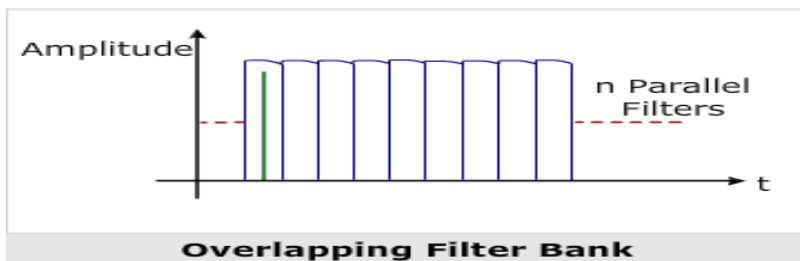
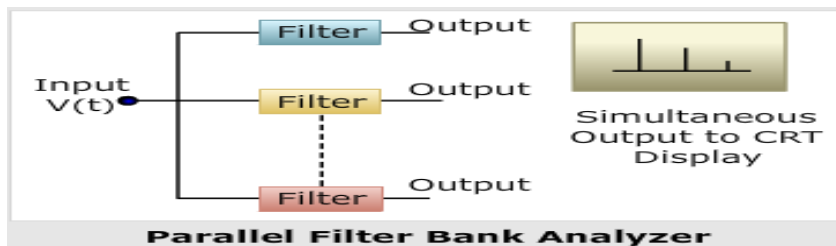

- For wideband narrow resolution analysis, particularly at RF or microwave signals, the swept technique is preferred.

### **Basic Spectrum Analyzer Using Swept Receiver Design**

- From the block diagram, the sawtooth generator provides sawtooth voltage, which drives the horizontal axis of the oscilloscope and this sawtooth voltage is the frequency controlled element of the voltage tuned oscillator.

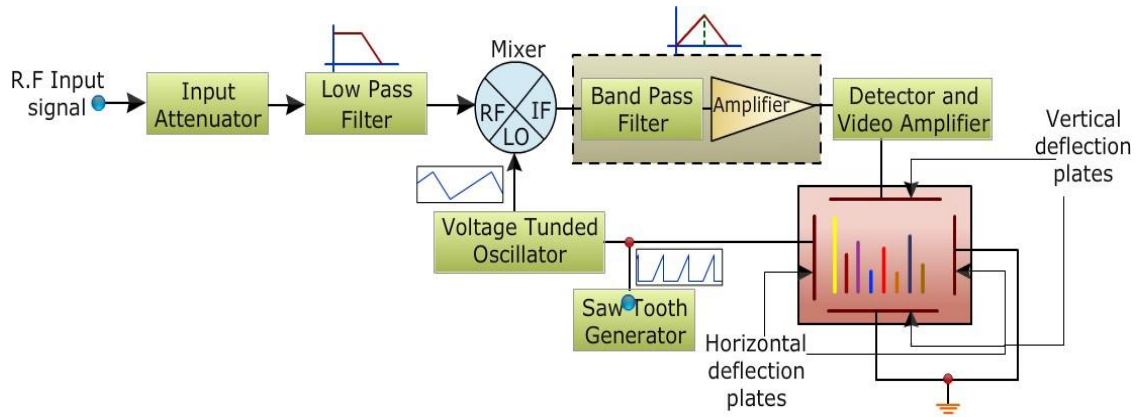

### Block Diagram of Spectrum Analyzer

- As the oscillator sweeps from  $f_{min}$  to  $f_{max}$  of its frequency band, it mixes with the frequency component of the input signal produces IF signal, the IF of the input signal is amplified and detected if necessary and then applied to the vertical plates of the CRO, Producing a display of amplitude vs frequency.

The spectrum produced if the input wave is single toned A.M. is given in fig a) Test waveform as seen on X-axis (Time) and Z-axis (Frequency), fig b) Test wave seen on ordinary CRO, fig c) Display on the spectrum CRO

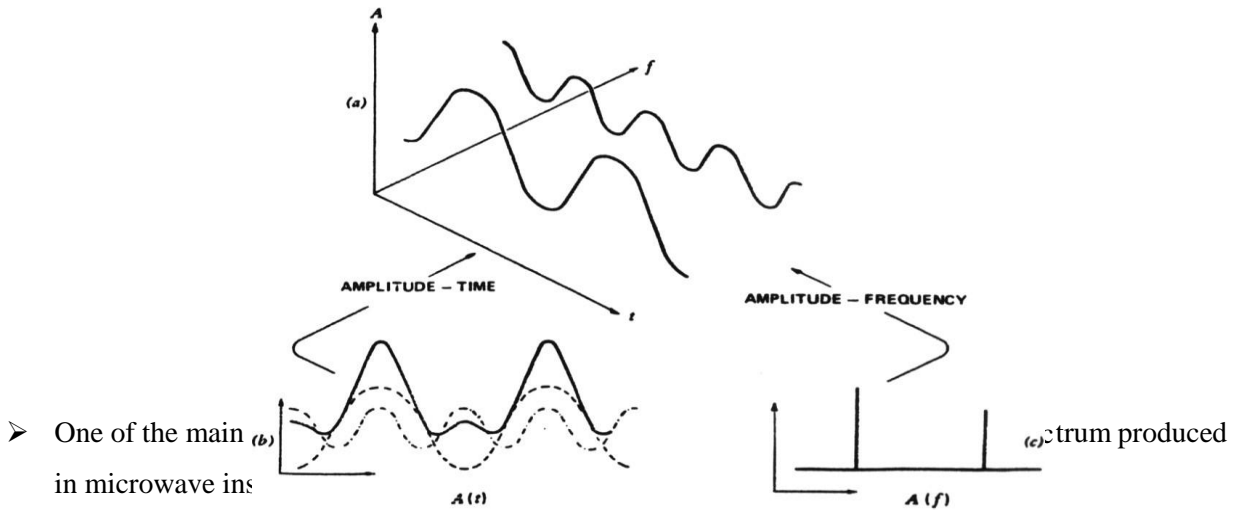

- One of the main (b) in microwave ins

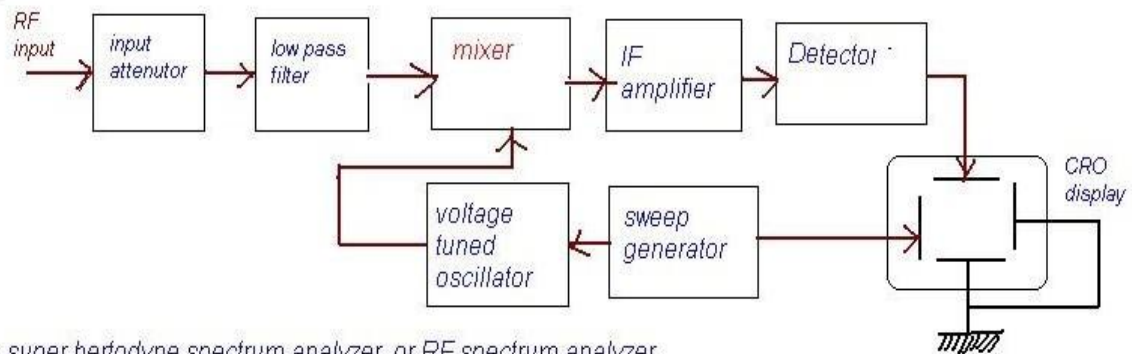

fig.: super heterodyne spectrum analyzer or RF spectrum analyzer

[www.ei-notes.blogspot.com](http://www.ei-notes.blogspot.com)

- One of the principle applications of spectrum analyzer has been seen in the study of RF Spectrum produced in Microwave instruments.
- The frequency range covered by this instrument is from 1MHz to 40 GHz.
- The input signal is fed into a mixer which is driven by a local oscillator. This oscillator is linearly tunable electrically over the range 2-3GHz.
- The mixer provides two signals at its output that are proportional in amplitude to the input signal but of frequencies which are sum and difference of the input signal and local oscillator frequency.
- The IF amplifier is tuned to narrow band around 2 GHz, since the local oscillator is tuned over the range of 2-3GHz, only inputs that are separated from local oscillator frequency by 2GHz will be converted to IF frequency band, pass through the IF frequency amplifier, get rectified and produces a vertical deflection on CRT.
- From this it is observed that as the sawtooth signal sweeps, the local oscillator also sweeps linearly from 2-3GHz. The tuning of the spectrum analyzer is a swept receiver which sweeps linearly from 0 to 1GHz. The sawtooth scanning signal is also applied to the horizontal plates of the CRT to form the frequency axis.
- The spectrum analyzer is also sensitive to signals from 4-5GHz referred to as the image frequency of the superheterodyne. A lowpass filter with a cutoff frequency above 1GHz at the input suppresses these spurious signals.
- Spectrum analyzers are widely used in radars, oceanography and bio-medical fields.

### Power Analyzers:

These instruments are used for

- 
- a) Testing and verifying correct operation of motors.
  - b) Checking transformer efficiency
  - c) Verifying power supply performance
  - d) Measuring the effect of neutral current

These features include harmonic analysis, power measurements and Pulse width modulation motor drive triggering. These instruments can also be used as oscilloscopes. which enable trouble shooting and verification of complicated electronic control circuits controlling the high-voltage power electronic circuits.

The bandwidth of the oscilloscope will be about 100MHZ.The sampling rate per channel is typically 500 samples/sec.These instruments can also be used as digital multimeters with a data logger. Some models in this category can measure harmonics upto thirty first harmonic with fundamental frequency ranging from 30 to 40HZ.

---

## UNIT IV AC AND DC BRIDGES

A bridge circuit consists of a network of four resistance arms forming a closed circuit with a DC source of current applied to two opposite junctions and a current detector connected to the other two arms.

Bridge circuits are used for measuring component values such as R, L and C. Bridge circuit compares the value of unknown component with the accurately known component. Its measurement accuracy can be very high. The measurement accuracy is directly related to the accuracy of the bridge component and not of the null detector used.

**Types of bridge** circuits used in measurement:

1) **DC bridge:**

- a) Wheatstone Bridge
- b) Kelvin Bridge

2) **AC bridge:**

- a) Similar Angle Bridge
- b) Opposite Angle Bridge/Hay Bridge
- c) Maxwell Bridge
- d) Wein Bridge
- e) Schering Bridge
- f) Anderson Bridge

### **Wheatstone bridge:**

The Wheatstone bridge is an *electrical bridge circuit* used to measure **resistance**. The Wheatstone bridge is the most accurate method for measuring resistance. This bridge consists of a

*galvanometer* and *two(2) parallel branches* containing **four(4)** resistors. One parallel branch contains one *known* resistance and one *unknown*; the other parallel branch contains resistors of **known resistances**. To operate the bridge, a *voltage source* is connected to two terminals of the bridge.

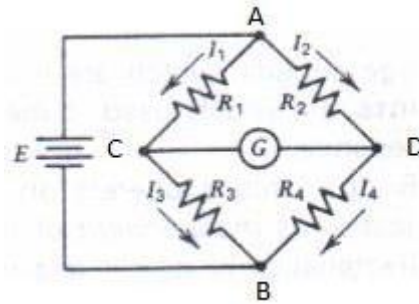

The galvanometer is a sensitive microammeter with a zero center scale.

When there is no current through the meter, the galvanometer pointer rests at  $0^\circ$ , i.e. mid at scale. Current in one direction causes the pointer to deflect in on one side and current in the opposite direction to other side.

### **Finding resistance of unknown resistor:**

The resistances of two resistors are *fixed* and the resistance of other one is *adjusted* until the current passing through the galvanometer *decreases to zero*.

$R_4$  is the unknown resistance.  $R_1$ ,  $R_2$  and  $R_3$  are resistors of known resistance where the resistance of  $R_3$  is adjustable.

When *no current* flows through the galvanometer, the bridge is called in a *balanced condition*.

When the bridge is in balanced condition, voltage drops across  $R_1$  and  $R_2$  are equal,

$$I_1 R_1 = I_2 R_2$$

And voltage drops across  $R_3$  and  $R_4$  are also equal,

$$I_3 R_3 = I_4 R_4$$

---

In this point of balance, we also obtain;

$$I_1 = I_3 \text{ and } I_2 = I_4$$

For the galvanometer current to be zero

$$I_1 = I_3 = E / (R_1 + R_3) \text{ and } I_2 = I_4 = E / (R_2 + R_4)$$

Therefore, the ratio of two resistances in the *known leg* is equal to the ratio of the two in the *unknown leg*;

$$\frac{R_3}{R_1} = \frac{R_4}{R_2} \qquad R_3 = R_4 \frac{R_2}{R_1}$$

Or

In practical Wheatstone bridge, at least one of the resistance is made adjustable to permit balancing of bridge. When the bridge is balanced, the unknown resistance may be determined from the setting of adjustable resistor, called a standard resistor.

$$R_x = R_3 \frac{R_2}{R_1}$$

### Sensitivity of Wheatstone Bridge:

When the pointer of a galvanometer deflects towards right or left hand side, this means that current is flowing through the galvanometer and the bridge is called in an *unbalanced condition*.

**Sensitivity** can be defined as **deflection per unit current**.

The *amount of deflection* is a function of the **sensitivity** of the galvanometer. For the same current, greater deflection of pointer indicates more sensitive a galvanometer.

Sensitivity S can be expressed in linear or angular units as follows

$$S = \frac{\text{Deflection}}{\text{Current}} = \frac{D}{I}$$

$$S = \frac{\text{mm}}{\mu\text{A}}$$

$$S = \frac{\text{deg ree}}{\mu\text{A}}$$

$$S = \frac{\text{radians}}{\mu\text{A}}$$

Therefore the total deflection

$$D=S*I$$

### Unbalanced Wheatstone bridge:

Thevenin's theorem is an approach used to determine the amount of deflection that will result for a particular degree of unbalance (current flowing through the galvanometer).

*Thevenin's equivalent voltage* is found by removing the galvanometer from the bridge circuit and computing the open-circuit voltage between terminals  $a$  and  $b$ .

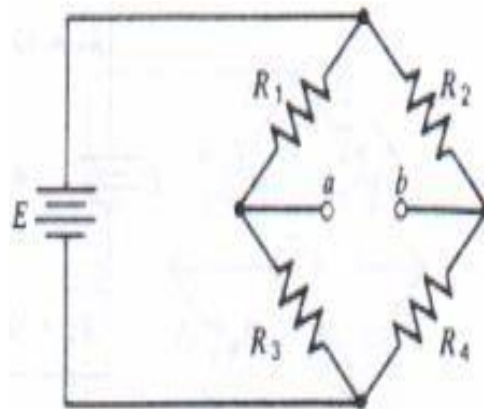

Applying the voltage divider equation, we express the voltage at point  $a$  and  $b$ , respectively, as

$$V_a = E \frac{R_3}{R_1 + R_3}$$

$$V_b = E \frac{R_4}{R_2 + R_4}$$

The difference in  $V_a$  and  $V_b$  represents Thevenin's equivalent voltage. That is,

$$V_{Th} = V_a - V_b = E \left( \frac{R_3}{R_1 + R_3} - \frac{R_4}{R_2 + R_4} \right)$$



Thevenin's equivalent resistance is found by replacing the voltage source with its internal resistance,  $R_s$ , as shown in Figure

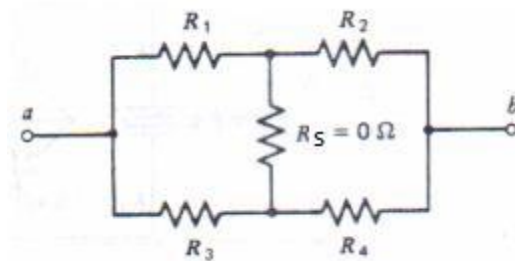

The equivalent resistance of the circuit is

$$R_{Th} = R_1 // R_3 + R_2 // R_4$$

$$R_{Th} = \frac{R_1 R_3}{R_1 + R_3} + \frac{R_2 R_4}{R_2 + R_4}$$

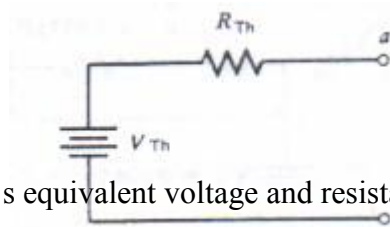

If the values of Thevenin's equivalent voltage and resistance have been known, the **Wheatstone bridge circuit** can be changed with **Thevenin's equivalent circuit**

If a galvanometer is connected to terminal a and b, the deflection current in the galvanometer is

$$I_g = \frac{V_{Th}}{R_{Th} + R_g}$$

where  $R_g$  = the internal resistance in the galvanometer

**Applications of Wheatstone bridge:**

- 
- Used to measure the DC resistance of various types of wires
  - Resistance of motor windings
  - Resistance of Transformers
  - Resistance of Relay coils
  - Used by telephone companies to locate cable faults

### **Limitations of Wheatstone bridge:**

- For low resistance measurement, the resistance of the leads and contacts becomes significant and introduces an error.
- For high resistance measurement, the resistance presented by the bridge becomes so large that the galvanometer is insensitive to imbalance.
- Change in resistance of the bridge arms due to heating effect of current through the resistance.
- The rise in temperature causes a change in the value of the resistance and excessive current may cause a permanent change in value.

### **Kelvin's Bridge (Thompson bridge):**

Kelvin bridge is a modified version of the Wheatstone bridge. The purpose of the modification is to eliminate the effects of contact and lead resistances in low resistance measurement.

The measurement with a high degree of accuracy can be done using the Kelvin bridge for resistors in the range of  $1 \Omega$  to approximately  $1 \mu\Omega$ .

Wheatstone bridge can be used for measuring the resistance from a few ohms to several kilo-ohms. **But error occurs in the result when it is used for measuring the low resistance.** This is the reason because of which the Wheatstone bridge is modified, and the Kelvin bridge obtains. The Kelvin bridge is suitable for measuring the low resistance.

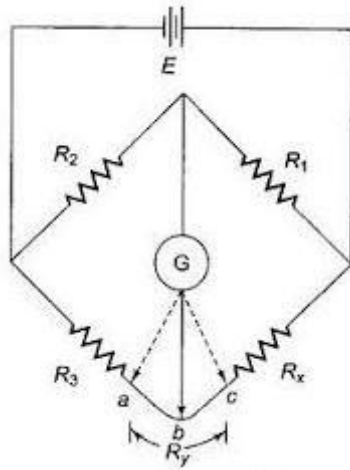

When the galvanometer is connected to point 'a', the lead resistance  $R_y$  is added to the standard resistance  $R_3$ . Thereby the very low indication obtains for unknown resistance  $R_x$ . And if the galvanometer is connected to point 'c' then the  $R_y$  adds to the  $R_x$ , and hence the high value of unknown resistance is obtained. Thus, at point c and a either very high or very low value of unknown resistance is obtained.

So, instead of connecting the galvanometer from point, a and c we chose any intermediate point say b where the resistance of lead  $R_y$  is divided into two equal parts.

$$\frac{R_{cb}}{R_{ab}} = \frac{R_1}{R_2} \quad \text{-----(1)}$$

And the usual balance equations for the bridge give relation

$$(R_x + R_{cb}) = \frac{R_1}{R_2} (R_3 + R_{ab}) \quad \text{-----(2)}$$

But  $R_{ab} + R_{cb} = R_y$  and  $\frac{R_{cb}}{R_{ab}} = \frac{R_1}{R_2}$

i.e.

$$\frac{R_y}{R_{ab}} = \frac{R_1 + R_2}{R_2}$$

---

Therefore

$$R_{ab} = \frac{R_2 R_y}{R_1 + R_2}$$

$$R_{cb} = R_y - R_{ab} = R_y - \frac{R_2 R_y}{R_1 + R_2}$$

$$R_{cb} = \frac{R_1 R_y}{R_1 + R_2}$$

Substituting for  $R_{ab}$  and  $R_{cb}$  in Equ(2)

$$R_x + \frac{R_1 R_y}{R_1 + R_2} = \frac{R_1 R_3}{R_2} + \frac{R_1 R_2 R_y}{R_2 (R_1 + R_2)}$$

Hence

$$R_x = \frac{R_1 R_3}{R_2} \quad \text{-----(3)}$$

This is the usual Wheatstone balance equation and indicates that the effect of resistance of leads from point a' to c' has been eliminated by connecting the galvanometer to an intermediate point b'.

This principle forms the basis of construction of Kelvin's Double Bridge.

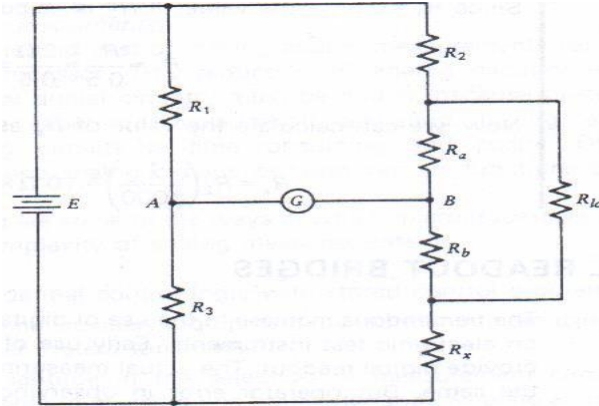

Since the Kelvin bridge uses a second set of ratio arms ( $R_a$  and  $R_b$ ), it is sometimes referred to as the **Kelvin's double bridge**.

The resistor  $R_{lc}$  represents the resistance of the connecting leads from  $R_2$  to  $R_x$  (unknown resistance).

The second set of ratio arms ( $R_a$  and  $R_b$  in figure) compensates for this relatively low lead-contact resistance.

When a null exists, the value for  $R_x$  is the same as that for the Wheatstone bridge, which is

$$R_x = \frac{R_2 R_3}{R_1} \quad \text{Or} \quad \frac{R_x}{R_2} = \frac{R_3}{R_1}$$

If the galvanometer is connected to point B, the ratio of  $R_b$  to  $R_a$  must be equal to the ratio of  $R_3$  to  $R_1$ . Therefore

$$\frac{R_x}{R_2} = \frac{R_3}{R_1} = \frac{R_b}{R_a}$$

### AC Bridges:

Impedances at AF or RF are commonly determined by means of an AC Wheatstone bridge. AC bridge has a similar circuit design as DC bridge, except that the bridge arms are impedances. The

impedances can be either pure resistances or complex impedances (resistance + inductance or resistance + capacitance). Therefore, AC bridges are used to measure inductance and capacitance.

Some impedance bridge circuits are frequency-sensitive while others are not. The frequency-sensitive types may be used as frequency measurement devices if all component values are accurately known.

The usefulness of AC bridge circuit is not restricted to the measurement of an unknown impedance. These circuits find other application in many communication systems and complex electronic circuits, such as for:

- shifting phase, providing feedback paths for oscillators or amplifiers;
- filtering out undesired signals;
- measuring the frequency of audio signals.

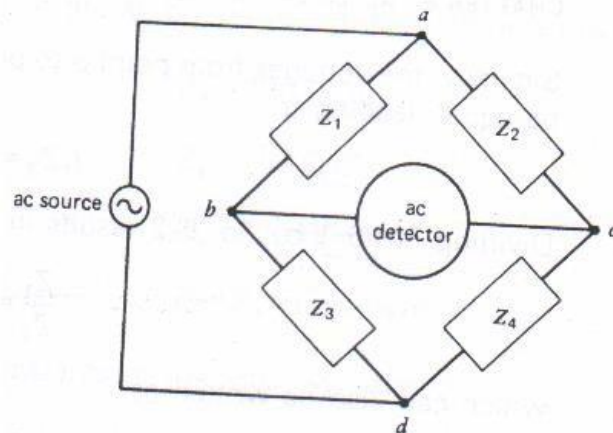

AC bridge is excited by an AC source and its galvanometer is replaced by a detector. The detector can be a sensitive electromechanical meter movements, oscilloscopes, headphones, or any other device capable of registering very small AC voltage levels.

AC bridge circuits work on the same basic principle as DC bridge circuits: that a balanced ratio of impedances (rather than resistances) will result in a -balanced condition as indicated by the null-detector.

When an AC bridge is in **null** or **balanced** condition, **the detector current becomes zero**. This means that **there is no voltage difference across the detector** and the bridge circuit in can be redrawn as

The dash line in the figure indicates that *there is no potential difference and no current* between points *b* and *c*. The voltages from point *a* to point *b* and from point *a* to point *c* must be equal, which allows us to obtain:

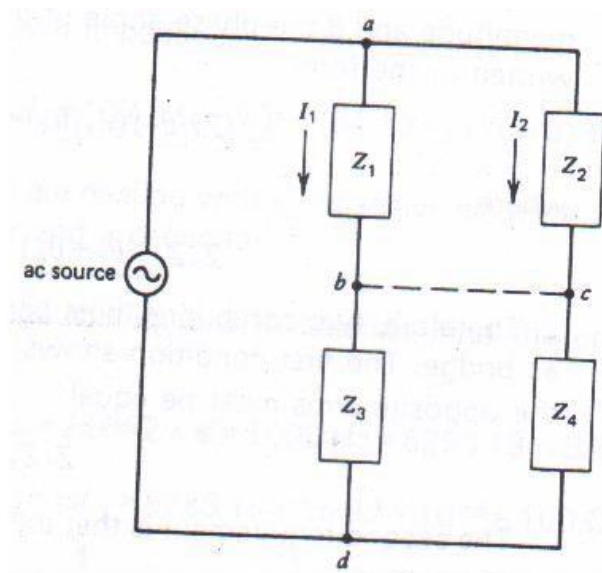

$$I_1 Z_1 = I_2 Z_2 \quad \text{-----(1)}$$

Similarly, the voltages from point *d* to point *b* and point *d* to point *c* must also be equal, leading to:

$$I_1 Z_3 = I_2 Z_4 \quad \text{-----(2)}$$

Dividing Equation (1) by Equation (2) we obtain

$$\frac{Z_1}{Z_3} = \frac{Z_2}{Z_4} \quad \text{Or} \quad \frac{Z_1 Z_4}{Z_3 Z_2} = \frac{Z_2 Z_3}{Z_4 Z_1}$$



If the impedance is written in the form  $Z = Z \angle \theta$  where  $Z$  represents the magnitude and  $\theta$  the phase angle of the complex impedance, can be written in the form

$$(Z_1 \angle \theta_1)(Z_4 \angle \theta_4) = (Z_2 \angle \theta_2)(Z_3 \angle \theta_3) \quad \text{-----(3)}$$

$$Z_1 Z_4 \angle (\theta_1 + \theta_4) = Z_2 Z_3 \angle (\theta_2 + \theta_3) \quad \text{-----(4)}$$

Eq. 4 shows two conditions when ac bridge is balanced;

- First condition shows that the products of the magnitudes of the opposite arms must be equal:

$$Z_1 Z_4 = Z_2 Z_3$$

- Second condition shows that the sum of the phase angles of the opposite arms is equal:

$$\angle \theta_1 + \angle \theta_4 = \angle \theta_2 + \angle \theta_3$$

#### Capacitance Comparison Bridge:

Below Figure shows the circuit of a capacitance comparison bridge. The ratio arms  $R_1$ ,  $R_2$  are resistive. The known standard capacitor  $C_3$  is in series with  $R_3$ .  $R_3$  may also include an added variable resistance needed to balance the bridge.  $C_x$  is the unknown capacitor and  $R_x$  is the small leakage resistance of the capacitor. In this case an unknown capacitor is compared with a standard capacitor and the value of the former, along with its leakage resistance is obtained.

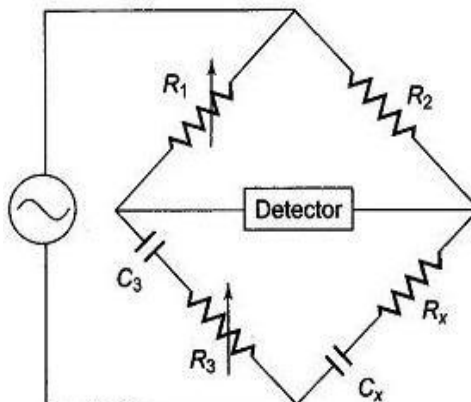

Hence

$$Z_1=R_1$$

$$Z_2=R_2$$

$$Z_3=R_3-j/\omega C_3$$

$$Z_x=R_x-j/\omega C_x$$

The condition for balance of the bridge is

$$Z_1 Z_x = Z_2 Z_3$$

$$R_1(R_x-j/\omega C_x)=R_2(R_3-j/\omega C_3)$$

Inductance **Comparison Bridge**:

Figure gives a schematic diagram of an inductance comparison bridge. In this, values of the unknown inductance  $L_x$  and its internal resistance  $R_x$  are obtained by comparison with the standard inductor and resistance, i.e.  $L_3$  and  $R_3$ .

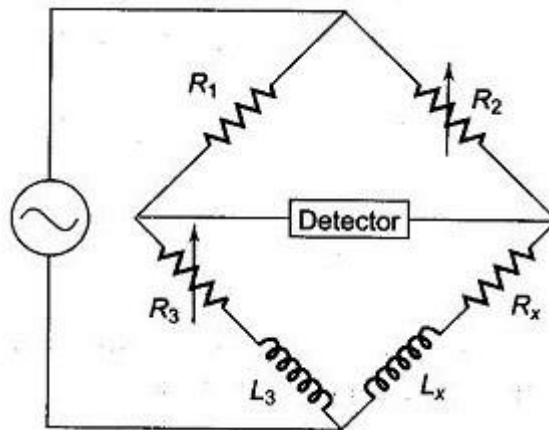

The equation for balance condition is

$$Z_1 Z_x = Z_2 Z_3$$

---

The inductive balance equation yields

$$L_x = \frac{L_3 R_2}{R_1}$$

and resistive balance equations yields

$$R_x = \frac{R_2 R_3}{R_1}$$

In this bridge  $R_2$  is chosen as the inductive balance control and  $R_3$  as the resistance balance control. (It is advisable to use a fixed resistance ratio and variable standards). Balance is obtained by alternately varying  $L_3$  or  $R_3$ . If the  $Q$  of the unknown reactance is greater than the standard  $Q$ , it is necessary to place a variable resistance in series with the unknown reactance to obtain balance.

If the unknown inductance has a high  $Q$ , it is permissible to vary the resistance ratio when a variable standard inductor is not available.

### **Maxwell Bridge:**

Maxwell bridge is an ac bridge used to measure an *unknown inductance* in terms of a *known capacitance*.

A **Maxwell bridge** is a modification to a Wheatstone bridge used to measure an unknown inductance (usually of low  $Q$  value) in terms of calibrated resistance and inductance or resistance and capacitance. When the calibrated components are a parallel resistor and capacitor, the bridge is known as a **Maxwell-Wien** bridge. It is named for James C. Maxwell, who first described it in 1873.

It uses the principle that the positive phase angle of an inductive impedance can be compensated by the negative phase angle of a capacitive impedance when put in the opposite arm and the circuit is at resonance; i.e., no potential difference across the detector (an AC voltmeter or ammeter)) and hence no current flowing through it. The unknown inductance then becomes known in terms of this capacitance.

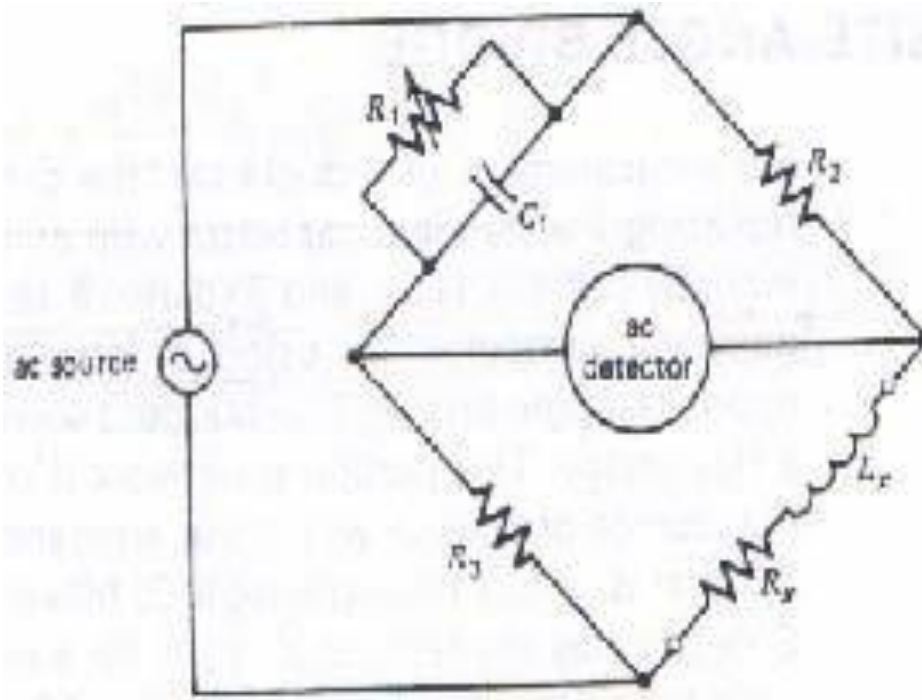

Using capacitance as a standard has several advantages due to:

- Capacitance of capacitor is influenced by less external fields.
- Capacitor has small size.
- Capacitor is low cost.

The impedance of the arms of the bridge can be written as

$$Z_1 = \frac{1}{\frac{1}{R_1} + j\omega C_1}$$

$$Z_2 = R_2$$

The general equation for bridge balance is

$$Z_3 = R_3$$

$$Z_4 = R_x + j X_{Lx}$$

---

Equating real terms and imaginary terms we have

$$R_x = \frac{R_2 R_3}{R_1}$$

$$j\omega L_x = j\omega R_2 R_3 C_1$$

$$L_x = R_2 R_3 C_1$$

A practical issue in construction of the bridge is mutual inductance: two inductors in propinquity will give rise to mutual induction: when the magnetic field of one intersects the coil of the other, it will reinforce the magnetic field in that other coil, and vice versa, distorting the inductance of both coils. To minimize mutual inductance, orient the inductors with their axes perpendicular to each other, and separate them as far as is practical. Similarly, the nearby presence of electric motors, chokes and transformers (like that in the power supply for the bridge!) may induce mutual inductance in the circuit components, so locate the circuit remotely from any of these.

The additional complexity of using a Maxwell-Wien bridge over simpler bridge types is warranted in circumstances where either the mutual inductance between the load and the known bridge entities, or stray electromagnetic interference, distorts the measurement results. The capacitive reactance in the bridge will exactly oppose the inductive reactance of the load when the bridge is balanced, allowing the load's resistance and reactance to be reliably determined.

### **Hay's Bridge(Opposite Angle Bridge):**

Maxwell bridge is only suitable for measuring medium quality factor coils however it is not suitable for measuring high quality factor ( $Q > 10$ ). In order to overcome from this limitation we need to do modification in Maxwell bridge so that it will become suitable for measuring Q factor over a wide range. This modified Maxwell bridge is known as Hay's bridge.

Opposite-angle bridge is an AC bridge for measurement of **inductance**. The construction of this bridge can be done by **replacing the standard capacitor of the similar-angle with an inductor**.

Opposite-angle bridge is sometimes known as a **Hay Bridge**. It differs from Maxwell bridge by having a **resistor  $R_1$**  in series with a **standard capacitor  $C_1$** .

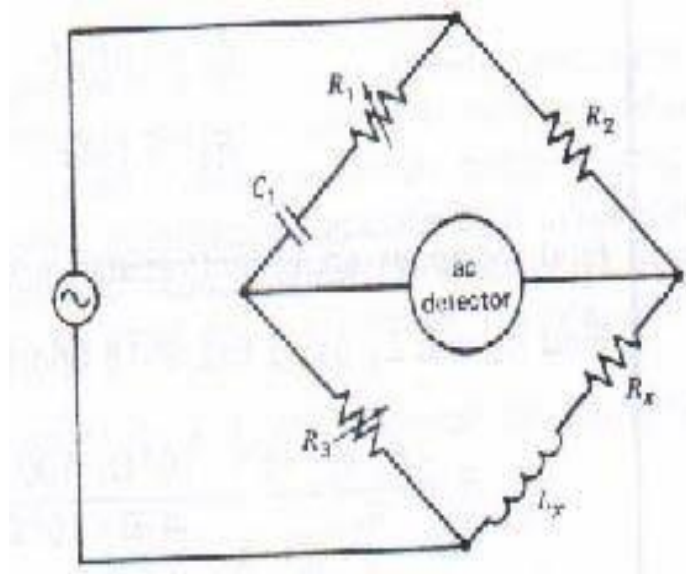

The impedance of the arms of the bridge can be written as

$$Z_1 = R_1 - \frac{j}{\omega C_1} \quad Z_2 = R_2$$

$$Z_3 = R_3 \quad Z_x = R_x + j\omega L_x$$

At balance:  $Z_1 Z_x = Z_2 Z_3$ , and substituting the values in the balance equation we obtain

$$\left( R_1 - \frac{j}{\omega C_1} \right) (R_x + j\omega L_x) = R_2 R_3$$

$$R_1 R_x + \frac{L_x}{C_1} - \frac{jR_x}{\omega C_1} + j\omega L_x R_1 = R_2 R_3$$

Equating the real and imaginary terms we have

$$R_1 R_x + \frac{L_x}{C_1} = R_2 R_3 \quad \text{-----(1)}$$

And

$$\frac{R_x}{\omega C_1} = \omega L_x R_1 \quad \text{-----(2)}$$

Solving for  $R_x$  we have,  $R_x = \omega^2 L_x C_1 R_1$ . Substituting for  $R_x$  in Eq 2

$$R_1 (\omega^2 R_1 C_1 L_x) + \frac{L_x}{C_1} = R_2 R_3$$

$$\omega^2 R_1^2 C_1 L_x + \frac{L_x}{C_1} = R_2 R_3$$

Multiplying both sides by  $C_1$  we get

$$\omega^2 R_1^2 C_1^2 L_x + L_x = R_2 R_3 C_1$$

Therefore,

$$L_x = \frac{R_2 R_3 C_1}{1 + \omega^2 R_1^2 C_1^2} \quad \text{-----(3)}$$

Substituting for  $L_x$  in Eq.3 into Eq.2, we obtain

$$R_x = \frac{\omega R_1 R_2 R_3 C_1^2}{1 + \omega^2 R_1^2 C_1^2} \quad \text{-----(4)}$$

---

The quality factor of the coil is

$$Q = \frac{\omega L_1}{R_1} = \frac{1}{\omega^2 C_4 R_4}$$

The equation of the unknown inductance and capacitance consists frequency term. Thus for finding the value of unknown inductance the frequency of the supply must be known.

For the high-quality factor, the frequency does not play an important role.

$$Q = \frac{1}{\omega^2 C_4 R_4}$$

Substituting the value of Q in the equation of unknown inductance, we get

$$L_1 = \frac{R_2 R_3 C_4}{1 + (1/Q)^2}$$

For greater value of Q the 1/Q is neglected and hence the equation become

$$L_1 = R_2 R_3 C_4$$

The term  $\omega$  in the expression for both  $L_x$  and  $R_x$  indicates that the bridge is frequency sensitive.

**Phasor Diagram of Hay's Bridge:**



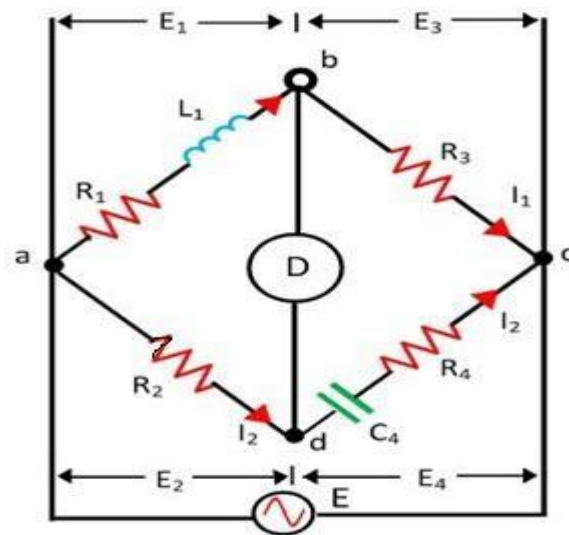

The phasor diagram of the Hay's bridge is shown in the figure below. The magnitude and the phase of the  $E_3$  and  $E_4$  are equal and hence they are overlapping each other and draw on the horizontal axis. The current  $I_1$  flow through the purely resistive arm  $bd$ . The current  $I_1$  and the potential  $E_3 = I_3R_3$  are in the same phase and represented on the horizontal axis.

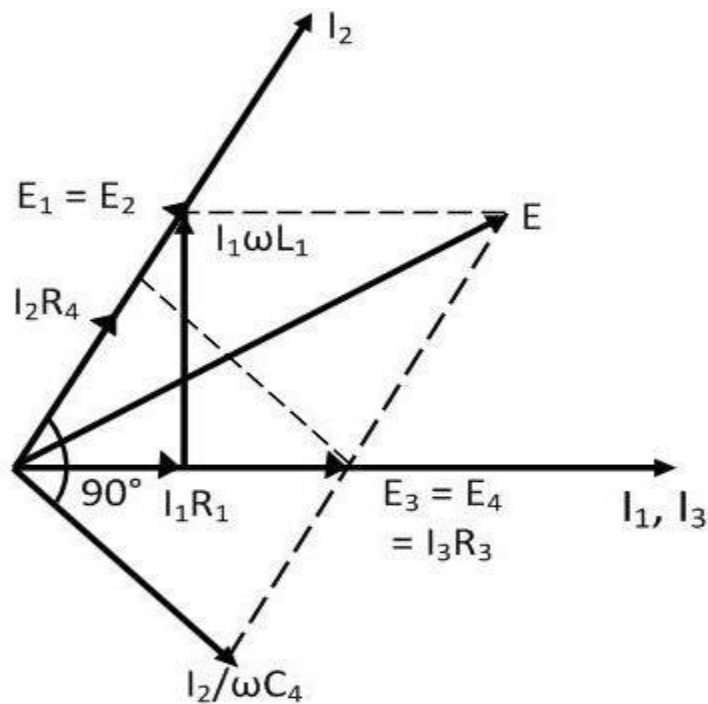

---

The current passes through the arm **ab** produces a potential drop  $I_1R_1$  which is also in the same phase of  $I_1$ . The total voltage drop across the arm **ab** is determined by adding the voltage  $I_1R_1$  and  $\omega I_1L_1$ .

The voltage drops across the arm **ab** and **ad** are equal. The voltage drop  $E_1$  and  $E_2$  are equal in magnitude and phase and hence overlap each other. The current  $I_2$  and  $E_2$  are in the same phase as shown in the figure above.

The current  $I_2$  flows through the arms **cd** and produces the  $I_2R_4$  voltage drops across the resistance and  $I_2/\omega C_4$  voltage drops across the capacitor  $C_4$ . The capacitance  $C_4$  lags by the currents  $90^\circ$ .

The voltage drops across the resistance  $C_4$  and  $R_4$  gives the total voltage drops across the arm **cd**. The sum of the voltage  $E_1$  and  $E_3$  or  $E_2$  and  $E_4$  gives the voltage drops  $E$ .

### **Advantages of Hay's Bridge**

The following are the advantages of Hay's Bridge.

1. The Hays bridges give a simple expression for the unknown inductances and are suitable for the coil having the quality factor greater than the 10 ohms.
2. It gives a simple equation for quality factor.
3. The Hay's bridge uses small value resistance for determining the Q factor.

### **Disadvantages of Hay's Bridge**

1. The only disadvantage of this type of bridge is that it is not suitable for the measurement of the coil having the quality factor less than 10 ohms.

**Hay's bridge** is not suitable for measurement of quality factor ( $Q < 10$ ), for  $Q < 10$  we should use Maxwell bridge.

### **Wien Bridge:**

The Wien bridge is a type of bridge circuit that was developed by Max Wien in 1891. The bridge consists of four resistors and two capacitors.

---

The Wien bridge is an ac bridge having a series RC combination in one arm and a parallel combination in the adjoining arm.

Wien's bridge is used for precision measurement of capacitance in terms of resistance and frequency. It was also used to measure audio frequencies.

The Wien bridge does not require equal values of  $R$  or  $C$ . At some frequency, the reactance of the series arm will be an exact multiple of the shunt arm. If the two arms are adjusted to the same ratio, then the bridge is balanced.

In its basic form, Wien's bridge is designed to measure either the **equivalent-parallel components** or the **equivalent-series components of an impedance**.

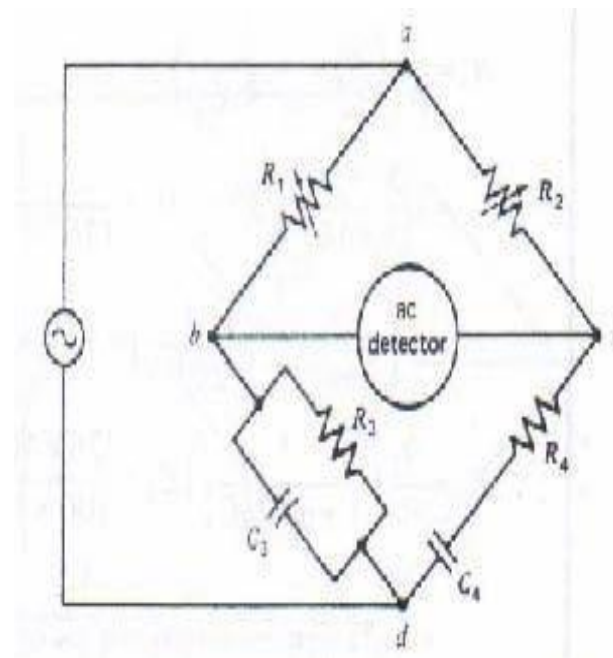

The impedance of the arms of this bridge can be written as:

$$Z_1 = R_1$$

$$Z_2 = R_2$$

The impedance of the parallel arm is

$$Z_3 = \frac{1}{\frac{1}{R_3} + j\omega C_3}$$

---

The impedance of the series arm is

$$Z_4 = R_4 - \frac{j}{\omega C_4}$$

Using the bridge balance equation,  $Z_1 Z_4 = Z_2 Z_3$  we obtain:

Equivalent parallel components

$$R_3 = \frac{R_1}{R_2} \left( R_4 + \frac{1}{\omega^2 R_4 C_4^2} \right) \quad \text{-----(1)}$$

$$C_3 = \frac{R_2}{R_1} \left( \frac{1}{1 + \omega^2 R_4^2 C_4^2} \right) C_4 \quad \text{-----(2)}$$

Equivalent series components

$$R_4 = \frac{R_2}{R_1} \left( \frac{R_3}{1 + \omega^2 R_3^2 C_3^2} \right)$$

$$C_3 = \frac{R_2}{R_1} \left( \frac{1}{1 + \omega^2 R_4^2 C_4^2} \right) C_4$$

Knowing the equivalent series and parallel components, Wien's bridge can also be used for the measurement of a frequency.

$$f = \frac{1}{2\pi\sqrt{R_3 C_3 R_4 C_4}}$$

### Schering Bridge:

Schering Bridge is a very important AC bridge used for precision measurement of capacitors and their insulating properties. Its basic circuit arrangement given in Figure shows that arm 1 contains a parallel combination of a resistor and a capacitor.

The standard capacitor  $C_3$  is a high quality mica capacitor for general measurements, or an air capacitor for insulation measurements.

A high quality mica capacitor has very low losses (no resistance) and an air capacitor has a very stable value and a very small electric field.

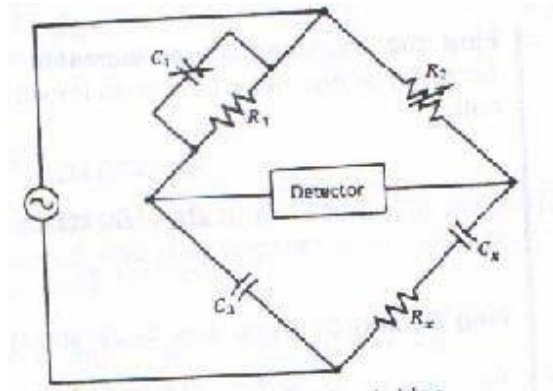

The impedance of the arms of the Schering bridge can be written as

$$Z_1 = \frac{1}{\frac{1}{R_1} + \frac{1}{-jX_{C1}}}$$

$$Z_2 = R_2$$

$$Z_3 = -jX_{C3}$$

$$Z_4 = R_x - jX_x$$

Substituting these values into general balance equation gives:

$$Z_4 = \frac{Z_2 Z_3}{Z_1}$$

$$R_x - jX_x = \frac{R_2(-jX_{C3})}{\frac{1}{\frac{1}{R_1} + \frac{1}{-jX_{C1}}}}$$

$$R_x - \frac{j}{\omega C_x} = R_2(-jX_{C3}) \left( \frac{1}{R_1} + \frac{1}{-jX_{C1}} \right)$$

$$R_x - \frac{j}{\omega C_x} = \frac{R_2 C_1}{C_3} - \frac{j R_2}{\omega C_1 R_1}$$

Equating the real and imaginary terms, we find that

$$R_x = R_2 \frac{C_1}{C_3}$$

$$C_x = C_3 \frac{R_1}{R_2}$$

### Anderson's Bridge:

The Anderson's bridge gives the accurate measurement of self-inductance of the circuit. The bridge is the advanced form of Maxwell's inductance capacitance bridge. In Anderson bridge, the unknown inductance is compared with the standard fixed capacitance which is connected between the two arms of the bridge.

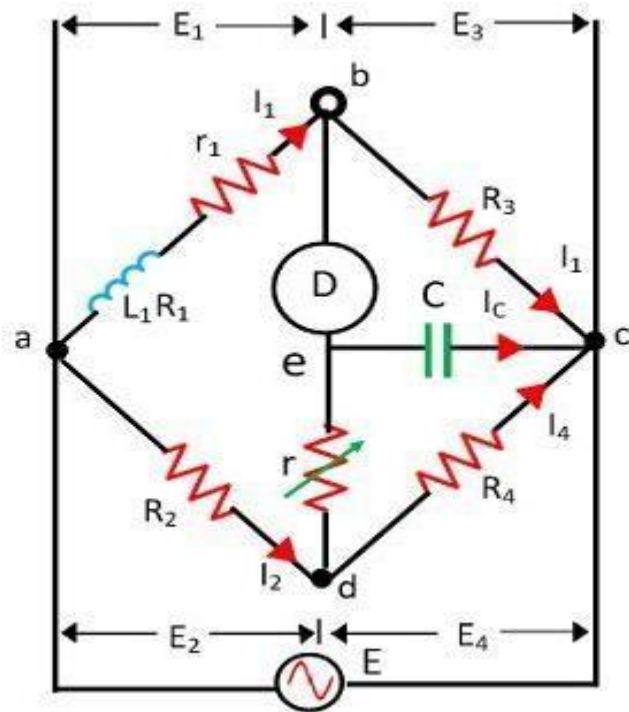

The bridge has four arms **ab**, **bc**, **cd**, and **ad**. The arm **ab** consists unknown inductance along with the resistance. And the other three arms consist the purely resistive arms connected in series with the circuit.

The static capacitor and the variable resistor are connected in series and placed in parallel with the **cd** arm. The voltage source is applied to the terminal a and c.

### Phasor Diagram:

The phasor diagram of the Anderson bridge is shown in the figure below. The current  $I_1$  and the  $E_3$  are in phase and represented on the horizontal axis. When the bridge is in balance condition the voltage across the arm **bc** and **ec** are equal.

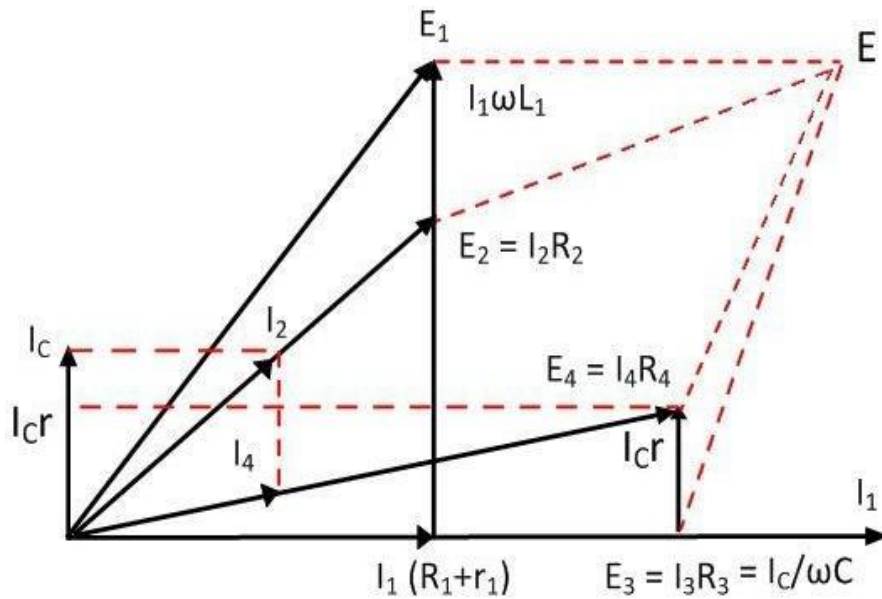

### Advantages of Anderson's Bridge:

- 1) In Anderson's bridge it is very easy to obtain the balance point as compared to Maxwell's bridge.
- 2) In this bridge a fixed standard capacitor is used therefore there is no need of costly variable capacitor.
- 3) This method is very accurate for measurement of capacitance in terms of inductance.

### Disadvantages:

- 1) Bridge is more complex
- 2) Difficult to attain balancing condition.

### Wagner Earth Connections:

- A serious problem encountered in sensitive ac bridge circuits is that due to stray capacitances.



- 
- Stray capacitances may be formed in an ac bridge between various junction points within the bridge configuration and nearest ground (earthed) object.
  - These stray capacitors affect bridge balance in severe ways since these capacitors carry leakage current when the bridge is operated with ac, especially at high frequencies.

1. A Maxwell bridge is used to measure an inductive impedance. The bridge constants at balance are  $C_1=0.01\mu\text{F}$ ,  $R_1=470\text{K}\Omega$ ,  $R_2=5.1\text{K}\Omega$  and  $R_3=100\text{K}\Omega$ . Find the series equivalent of unknown impedance.

Solution:

$$\begin{aligned}R_x &= R_2R_3/R_1 \\ &= 100\text{K} * 5.1\text{K}/470\text{K} \\ &= 1.09\text{K}\Omega \\ L_x &= R_2R_3C_1 \\ &= 5.1\text{K} * 100\text{K} * 0.01\mu \\ &= 5.1 \text{ H}\end{aligned}$$

2. An inductance comparison bridge is used to measure inductive impedance at a frequency of 5KHz. The bridge constants at balance are  $L_3=10\text{mH}$ ,  $R_1=10\text{K}\Omega$ ,  $R_2=40\text{K}\Omega$ ,  $R_3=100\text{K}\Omega$ . Find the equivalent series circuit of the unknown impedance.

Solution:

$$\begin{aligned}R_x &= R_2R_3/R_1 \\ &= 40\text{K} * 100\text{K}/10\text{K} \\ &= 400\text{K}\Omega\end{aligned}$$

---

$$\begin{aligned}L_x &= R_2 L_3 / R_1 \\ &= 10\text{mH} * 40\text{K} / 10\text{K} \\ &= 40\text{m H}\end{aligned}$$

4. A capacitance comparison bridge is used to measure capacitive impedance at a frequency of 2KHz. The bridge constants at balance are  $C_3=100\mu\text{F}$ ,  $R_1=10\text{K}\Omega$ ,  $R_2=50\text{K}\Omega$ ,  $R_3=100\text{K}\Omega$ . Find the equivalent series circuit of the unknown impedance.

Solution:

$$\begin{aligned}R_x &= R_2 R_3 / R_1 \\ &= 100\text{K} * 50\text{K} / 10\text{K} \\ &= 500\text{K}\Omega\end{aligned}$$

$$\begin{aligned}C_x &= R_1 C_3 / R_2 \\ &= 10\text{K} * 100\mu\text{F} / 50\text{K} \\ &= 20\mu\text{F}\end{aligned}$$

---

## UNIT-V TRANSDUCER

### INTRODUCTION

A device which converts a physical quantity into the proportional electrical signal is called a transducer. The electrical signal produced may be a voltage, current or frequency. A transducer uses many effects to produce such conversion. The process of transforming signal from one form to other is called transduction. A transducer is also called pick up. The transduction element transforms the output of the sensor to an electrical output, as shown in the Fig.

A transducer will have basically two main components. They are

#### 1. Sensing Element

The physical quantity or its rate of change is sensed and responded to by this part of the transistor.

#### 2. Transduction Element

The output of the sensing element is passed on to the transduction element. This element is responsible for converting the non-electrical signal into its proportional electrical signal.

There may be cases when the transduction element performs the action of both transduction and sensing. The best example of such a transducer is a thermocouple. A thermocouple is used to generate a voltage corresponding to the heat that is generated at the junction of two dissimilar metals.

### Classification of Transducers

The Classification of Transducers is done in many ways. Some of the criteria for the classification are based on their area of application, Method of energy conversion, Nature of output signal, According to Electrical principles involved, Electrical parameter used, principle of operation, & Typical applications. The transducers can be classified broadly i. On the basis of transduction form used ii. As primary and secondary transducers iii. As active and passive transducers iv. As transducers and inverse transducers. Broadly one such generalization is concerned with energy considerations wherein they are classified as active & Passive transducers. A component whose output energy is supplied entirely by its input signal (physical quantity under measurement) is commonly called a „passive transducer“. In other words the passive transducers derive the power required for transduction from an auxiliary source. Active transducers are those which do not require an auxiliary power source to produce their output. They are also known as self generating type since they produce their own voltage or current output. Some of the passive transducers ( electrical transducers), their electrical parameter (resistance, capacitance, etc), principle of operation and applications are listed below.

#### Resistive Transducers

1. Resistance Strain Gauge – The change in value of resistance of metal semi-conductor due to elongation or compression is known by the measurement of torque, displacement or force.

- 
2. Resistance Thermometer – The change in resistance of metal wire due to the change in temperature known by the measurement of temperature.
  3. Resistance Hygrometer – The change in the resistance of conductive strip due to the change of moisture content is known by the value of its corresponding humidity.
  4. Hot Wire Meter – The change in resistance of a heating element due to convection cooling of a flow of gas is known by its corresponding gas flow or pressure.
  5. Photoconductive Cell – The change in resistance of a cell due to a corresponding change in light flux is known by its corresponding light intensity.
  6. Thermistor – The change in resistance of a semi-conductor that has a negative co-efficient of resistance is known by its corresponding measure of temperature.
  7. Potentiometer Type – The change in resistance of a potentiometer reading due to the movement of the slider as a part of an external force applied is known by its corresponding pressure or displacement.

### **Capacitance Transducers**

1. Variable capacitance pressure gage - Principle of operation: Distance between two parallel plates is varied by an externally applied force Applications: Measurement of Displacement, pressure
2. Capacitor microphone Principle of operation: Sound pressure varies the capacitance between a fixed plate and a movable diaphragm. Applications: Speech, music, noise
3. Dielectric gauge Principle of operation: Variation in capacitance by changes in the dielectric. Applications: Liquid level, thickness

### **Inductance Transducers**

1. Magnetic circuit transducer Principle of operation: Self inductance or mutual inductance of ac-excited coil is varied by changes in the magnetic circuit. Applications: Pressure, displacement
2. Reluctance pickup Principle of operation: Reluctance of the magnetic circuit is varied by changing the position of the iron core of a coil. Applications: Pressure, displacement, vibration, position
3. Differential transformer Principle of operation: The differential voltage of two secondary windings of a transformer is varied by positioning the magnetic core through an externally applied force. Applications: Pressure, force, displacement, position
4. Eddy current gage Principle of operation: Inductance of a coil is varied by the proximity of an eddy current plate. Applications: Displacement, thickness
5. Magnetostriction gauge Principle of operation: Magnetic properties are varied by pressure and stress. Applications: Force, pressure, sound

---

## **Voltage and current Transducers**

1. Hall effect pickup Principle of operation: A potential difference is generated across a semiconductor plate (germanium) when magnetic flux interacts with an applied current. Applications: Magnetic flux, current
2. Ionization chamber Principle of operation: Electron flow induced by ionization of gas due to radioactive radiation. Applications: Particle counting, radiation
3. Photoemissive cell Principle of operation: Electron emission due to incident radiation on photoemissive surface. Applications: Light and radiation
4. Photomultiplier tube

Principle of operation: Secondary electron emission due to incident radiation on photosensitive cathode.  
Applications: Light and radiation, photo-sensitive relays

## **Self-Generating Transducers (No External Power) – Active Transducers**

They do not require an external power, and produce an analog voltage or current when stimulated by some physical form of energy.

1. Thermocouple and thermopile Principle of operation: An emf is generated across the junction of two dissimilar metals or semiconductors when that junction is heated. Applications: Temperature, heat flow, radiation.
2. Moving-coil generator Principle of operation: Motion of a coil in a magnetic field generates a voltage. Applications: Velocity. Vibration
3. Piezoelectric pickup An emf is generated when an external force is applied to certain crystalline materials, such as quartz Sound, vibration. acceleration, pressure changes
4. Photovoltaic cell Principle of operation: A voltage is generated in a semi-conductor junction device when radiant energy stimulates the cell Applications: Light meter, solar cell

Primary Transducers and Secondary Transducers- Bourden tube acting as a primary detector senses the pressure and converts the pressure into a displacement of its free end. The displacement of the free end moves the core of a linear variable differential transformer (LVDT) which produces an output voltage.

Analog Transducers- These transducers convert the input quantity into an analog output which is a continuous function of time. ◦ Strain Gauge ◦ LVDT ◦ Thermocouple ◦ Thermistor

Digital Transducers- These transducers convert the input quantity into an electrical output which is in the form of pulses. ◦ Glass Scale can be read optically by means of a light source, an optical system and photocells Transducers and Inverse Transducers- -A Transducer can be broadly defined as a device which converts a non-electrical quantity into an electrical quantity. Ex: -Resistive, inductive and capacitive

---

transducers -An inverse transducer is defined as a device which converts an electrical quantity into a non-electrical quantity. Ex:-Piezoelectric crystals

### **Advantages of Electrical transducers**

Mostly quantities to be measured are non-electrical such as temperature, pressure, displacement, humidity, fluid flow, speed etc., but these quantities cannot be measured directly. Hence such quantities are required to be sensed and changed into some other form for easy measurement. Electrical quantities such as current, voltage, resistance, inductance and capacitance etc. can be conveniently measured, transferred and stored, and, therefore, for measurement of the non-electrical quantities these are to be converted into electrical quantities first and then measured. The function of converting non-electrical quantity into electrical one is accomplished by a device called the electrical transducer.

Basically an electrical transducer is a sensing device by which a physical, mechanical or optical quantity to be measured is transformed directly, with a suitable mechanism, into an electrical signal (current, voltage and frequency). The production of these signals is based upon electrical effects which may be resistive, inductive, capacitive etc. in nature. The input versus output energy relationship takes a definite reproducible function. The output to input and the output to time behavior is predictable to a known degree of accuracy, sensitivity and response, within the specified environmental conditions. Electrical transducers have numerous advantages. Modern digital computers have made use of electrical transducers absolutely essential.

Electrical transducers suffer due to some draw-backs too, such as low reliability in comparison to that of mechanical transducers due to the ageing and drift of the active components and comparative high cost of electrical transducers and associated signal conditioners. In some cases the accuracy and resolution attainable are not as high as in mechanical transducers.

Some of the advantages are:

1. Electrical amplification and attenuation can be done easily and that too with a static device.
2. The effect of friction is minimized.
3. The electric or electronic system can be controlled with a very small electric power.
4. The electric power can be easily used, transmitted and processed for the purpose of measurement.

### **Factor to be considered while selecting transducer:**

It should have high input impedance and low output impedance, to avoid loading effect. It should have good resolution over its entire selected range. It must be highly sensitive to desired signal and insensitive to unwanted signal.

Preferably small in size. It should be able to work in a corrosive environment. It should be able to withstand pressure, shocks, vibrations etc.. It must have a high degree of accuracy and repeatability. Selected transducer must be free from errors.

The transducer circuit should have overload protection so that it will withstand overloads.

**Requirements of a good transducers**

- Smaller in size and weight.
- High sensitivity.
- Ability to withstand environmental conditions.
- Low cost.

**STRAIN GAUGE**

**What is Strain?**

Strain is the amount of deformation of a body due to an applied force. More specifically, strain ( $\epsilon$ ) is defined as the fractional change in length, as shown in Figure 1 below.

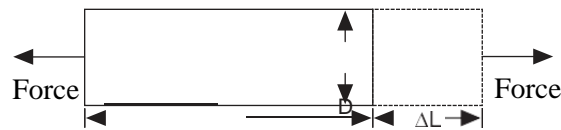

L

$$\epsilon = \frac{\Delta L}{L}$$

**Figure . Definition of Strain**

Strain can be positive (tensile) or negative (compressive). Although dimensionless, strain is sometimes expressed in units such as in./in. or mm/mm. In practice, the magnitude of measured strain is very small.

Therefore, strain is often expressed as microstrain ( $\mu\epsilon$ ), which is  $10^{-6}$ .

When a bar is strained with a uniaxial force, as in Figure 1, a phenomenon known as Poisson Strain causes the girth of the bar, D, to contract in the transverse, or perpendicular, direction. The magnitude of this

---

transverse contraction is a material property indicated by its Poisson's Ratio. The Poisson's Ratio  $\nu$  of a material is defined as the negative ratio of the strain in the transverse direction (perpendicular to the force) to the strain in the axial direction (parallel to the force), or  $\nu = -\epsilon_T/\epsilon$ . Poisson's Ratio for steel, for example, ranges from 0.25 to 0.3.

## The Strain Gauge

While there are several methods of measuring strain, the most common is with a strain gauge, a device whose electrical resistance varies in proportion to the amount of strain in the device. For example, the piezoresistive strain gauge is a semiconductor device whose resistance varies nonlinearly with strain. The most widely used gauge, however, is the bonded metallic strain gauge.

The metallic strain gauge consists of a very fine wire or, more commonly, metallic foil arranged in a grid pattern. The grid pattern maximizes the amount of metallic wire or foil subject to strain in the parallel direction (Figure 2). The cross sectional area of the grid is minimized to reduce the effect of shear strain and Poisson Strain. The grid is bonded to a thin backing, called the carrier, which is attached directly to the test specimen. Therefore, the strain experienced by the test specimen is transferred directly to the strain gauge, which responds with a linear change in electrical resistance. Strain gauges are available commercially with nominal resistance values from 30 to 3000  $\Omega$ , with 120, 350, and 1000 being the most common values.

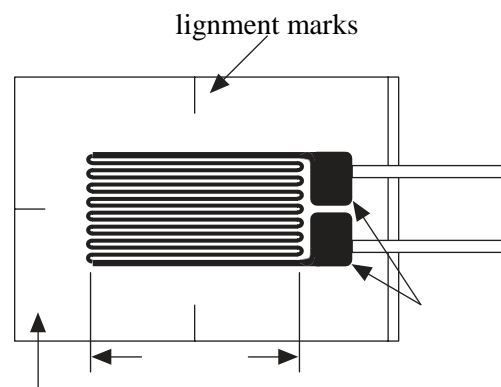



The Gauge Factor for metallic strain gauges is typically around 2.

Ideally, we would like the resistance of the strain gauge to change only in response to applied strain. However, strain gauge material, as well as the specimen material to which the gauge is applied, will also respond to changes in temperature. Strain gauge manufacturers attempt to minimize sensitivity to temperature by processing the gauge material to compensate for the thermal expansion of the specimen material for which the gauge is intended. While compensated gauges reduce the thermal sensitivity, they do not totally remove it. For example, consider a gauge compensated for aluminum that has a temperature coefficient of 23 ppm/°C. With a nominal resistance of 1000 Ω and GF = 2, the equivalent strain error is still 11.5 με/°C. Therefore, additional temperature compensation is important.

### Strain Gauge Measurement

In practice, the strain measurements rarely involve quantities larger than a few millistrain (ε ≈ 10<sup>-3</sup>). Therefore, to measure the strain requires accurate measurement of very small changes in resistance. For example, suppose a test specimen undergoes a substantial strain of 500 με. A strain gauge with a gauge factor GF = 2 will exhibit a change in electrical resistance of only 2 × (500 × 10<sup>-6</sup>) = 0.1%. For a 120 Ω gauge, this is a change of only 0.12 Ω.

To measure such small changes in resistance, and compensate for the temperature sensitivity discussed in the previous section, strain gauges are almost always used in a bridge configuration with a voltage or current excitation source. The general Wheatstone bridge, illustrated below, consists of four resistive arms with an excitation voltage, V<sub>EX</sub>, that is applied across the bridge.

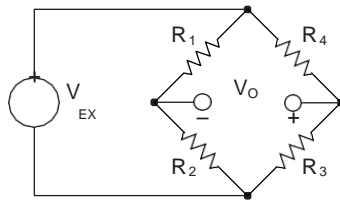

Figure . Wheatstone Bridge

The output voltage of the bridge, V<sub>O</sub>, will be equal to:

$$V_O = \frac{R_3}{R_2 + R_3} V_{EX}$$

$$R_3 + R_4 = R_1 + R_2$$

From this equation, it is apparent that when  $R_1/R_2 = R_G/R_{G2}$ , the voltage output  $V_O$  will be zero. Under these conditions, the bridge is said to be *balanced*. Any change in resistance in any arm of the bridge will result in a nonzero output voltage.

Therefore, if we replace  $R_4$  in Figure 3 with an active strain gauge, any changes in the strain gauge resistance will unbalance the bridge and produce a nonzero output voltage. If the nominal resistance of the strain gauge is designated as  $R_G$ , then the strain-induced change in resistance,  $\Delta R$ , can be expressed as  $\Delta R = R_G \Delta GF \epsilon$ . Assuming that  $R_1 = R_2$  and  $R_3 = R_G$ , the bridge equation above can be rewritten to express  $V_O/V_{EX}$  as a function of strain (see Figure 4). Note the presence of the  $1/(1+GF \epsilon / 2)$  term that indicates the nonlinearity of the quarter-bridge output with respect to strain.

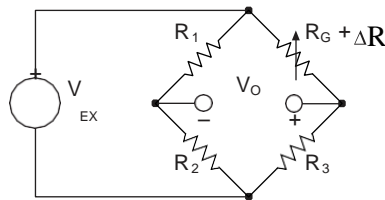

**Figure . Quarter-Bridge Circuit**

By using *two* strain gauges in the bridge, the effect of temperature can be avoided. For example, Figure 5 illustrates a strain gauge configuration where one gauge is active ( $R_G \Delta R$ ) and a second gauge is placed transverse to the applied strain. Therefore, the strain has little effect on the second gauge, called the dummy gauge. However, any changes in temperature will affect both gauges in the same way. Because the temperature changes are identical in the two gauges, the ratio of their resistance does not change, the voltage  $V_O$  does not change, and the effects of the temperature change are minimized.

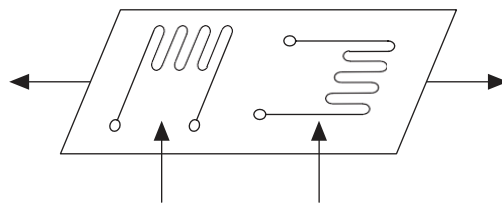

Dummy Gauge

( $R_G$ , inactive)

**Figure . Use of Dummy Gauge to Eliminate Temperature Effects**

Alternatively, you can double the sensitivity of the bridge to strain by making both gauges active, although in different directions. For example, Figure 6 illustrates a bending beam application with one bridge mounted in tension ( $R_G + \Delta R$ ) and the other mounted in compression ( $R_G - \Delta R$ ). This half-bridge configuration, whose circuit diagram is also illustrated in Figure 6, yields an output voltage that is linear and approximately doubles the output of the quarter-bridge circuit.

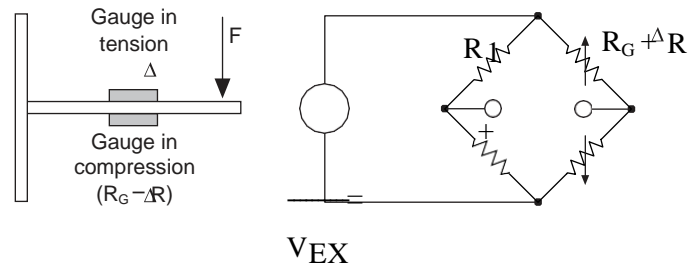

**Figure . Half-Bridge Circuit**

Finally, you can further increase the sensitivity of the circuit by making all four of the arms of the bridge active strain gauges, and mounting two gauges in tension and two gauges in compression. The full-bridge circuit is shown in Figure 7 below.

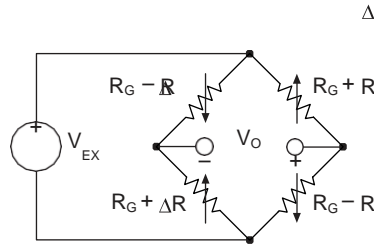

**Figure . Full-Bridge Circuit**

The equations given here for the Wheatstone bridge circuits assume an initially balanced bridge that generates zero output when no strain is applied. In practice however, resistance tolerances and strain induced by gauge application will generate some initial offset voltage. This initial offset voltage is typically handled in two ways.

First, you can use a special offset-nulling, or balancing, circuit to adjust the resistance in the bridge to rebalance the bridge to zero output. Alternatively, you can measure the initial unstrained output of the circuit and compensate in software.

At the end of this application note, you will find equations for quarter, half, and full bridge circuits that express strain that take initial output voltages into account. These equations also include the effect of resistance in the lead wires connected to the gauges.

### **Strain Gauge Equations**

This section includes the complete strain gauge equations for several types of bridge configurations. These equations are included as callable functions (with source code) with the NI-DAQ driver software. The function names are `Strain_Convert` and `Strain_Buf_Convert`. With LabVIEW, these equations are included in the *Convert Strain Gauge Reading.vi* in the DAQ Utilities menu.

To simplify the equations and account for unbalanced bridges in the nonstrained state, let us introduce the

where  $V_{O(\text{strained})}$  is the measured output when strained, and  $V_{O(\text{unstrained})}$  is the initial, unstrained output voltage.  $V_{EX}$  is the excitation voltage.

Other nomenclature used in the equations include:  $R_G$  = nominal resistance value of strain gauge  
 $GF$  = gauge factor of strain gauge

$R_L$  = lead resistance

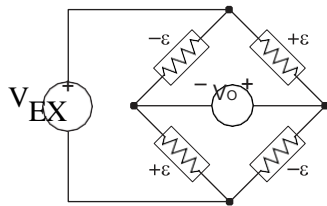

**Full-Bridge I**

$$\text{strain} = \frac{-V}{GF + 1} \cdot \frac{r}{F}$$

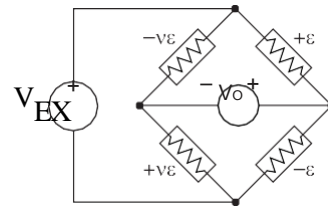

**Full-Bridge II**

$$\text{strain} = \frac{-2V}{GF + 1} \cdot \frac{r}{F}$$

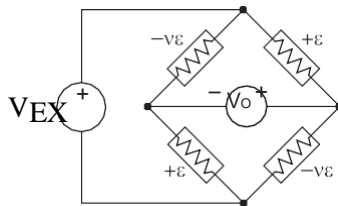

---

## RESISTANCE THERMOMETERS

It is well known that resistance of metallic conductors increases with temperature, while that of semiconductors generally decreases with temperature. Resistance thermometers employing metallic conductors for temperature measurement are called *Resistance Temperature Detector (RTD)*, and those employing semiconductors are termed as *Thermistors*. RTDs are more rugged and have more or less linear characteristics over a wide temperature range. On the other hand Thermistors have high temperature sensitivity, but nonlinear characteristics.

### Resistance Temperature Detector

The variation of resistance of metals with temperature is normally modeled in the form:

$$R_t = R_0 [1 + \alpha(t - t_0) + \beta(t - t_0)^2 + \dots] \quad (1)$$

where  $R_t$  and  $R_0$  are the resistance values at  $t^\circ\text{C}$  and  $t_0^\circ\text{C}$  respectively;  $\alpha$ ,  $\beta$ , etc. are constants

that depends on the metal. For a small range of temperature, the expression can be approximated as:

$$R_t = R_0 [1 + \alpha(t - t_0)] \quad (2)$$

For Copper,  $\alpha = 0.00427 / ^\circ\text{C}$ .

Copper, Nickel and Platinum are mostly used as RTD materials. The range of temperature measurement is decided by the region, where the resistance-temperature characteristics are approximately linear. The resistance versus temperature characteristics of these materials is shown in fig.1, with  $t_0$  as  $0^\circ\text{C}$ . Platinum has a linear range of operation upto  $650^\circ\text{C}$ , while the useful range for Copper and Nickel are  $120^\circ\text{C}$  and  $300^\circ\text{C}$  respectively.

### Construction

---

For industrial use, bare metal wires cannot be used for temperature measurement. They must be protected from mechanical hazards such as material decomposition, tearing and other physical damages. The salient features of construction of an industrial RTD are as follows:

- The resistance wire is often put in a stainless steel well for protection against mechanical hazards. This is also useful from the point of view of maintenance, since a defective sensor can be replaced by a good one while the plant is in operation.
- Heat conducting but electrical insulating materials like mica is placed in between the well and the resistance material.
- The resistance wire should be carefully wound over mica sheet so that no strain is developed due to length expansion of the wire.

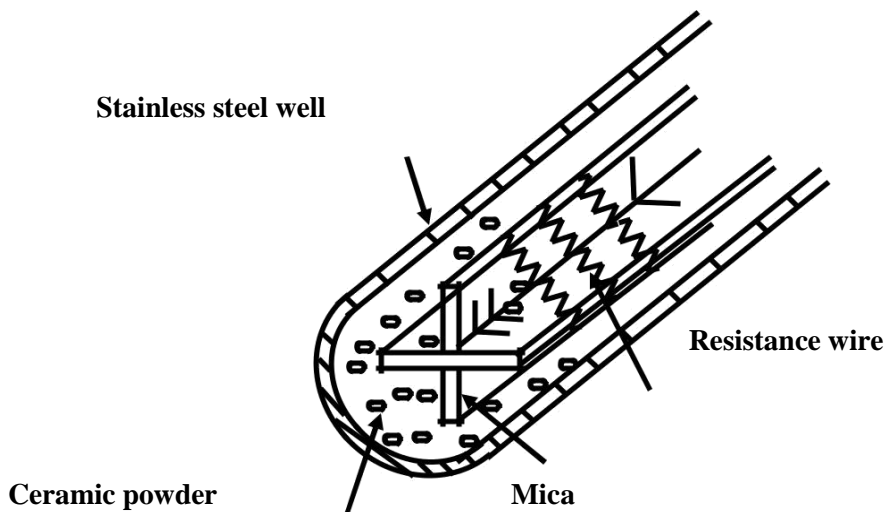

**Fig. 2 Construction of an industrial RTD**

### Signal conditioning

The resistance variation of the RTD can be measured by a bridge, or directly by volt-ampere method. But the major constraint is the contribution of the lead wires in the overall resistance measured. Since the length of the lead wire may vary, this may give a false reading in the temperature to be measured. There must be some method for compensation so that the effect of lead wires is resistance measured is eliminated.

This can be achieved by using either a *three wire RTD*, or a *four wire RTD*. Both the schemes of measurement are shown in fig. 3. In three wire method one additional dummy wire taken from the resistance element and connected in a bridge (fig. 3(a)) so that the two lead wires are connected to two adjacent arms of the bridge, thus canceling each other's effect. In fig. 3(b) the four wire method of measurement is shown. It is similar to a four terminal resistance and two terminals are used for injecting current, while two others are for measuring voltage.

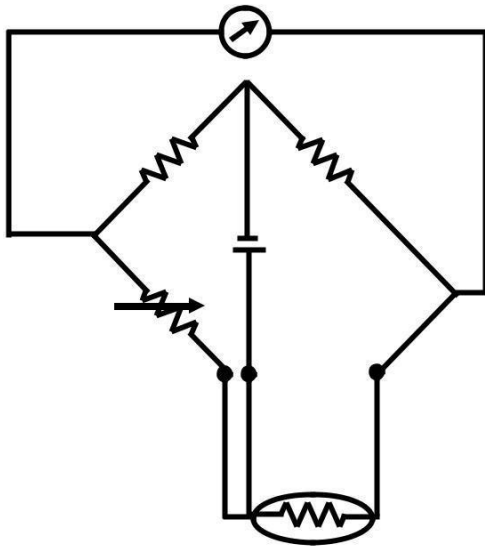

Fig. 3(a) Three wire RTD

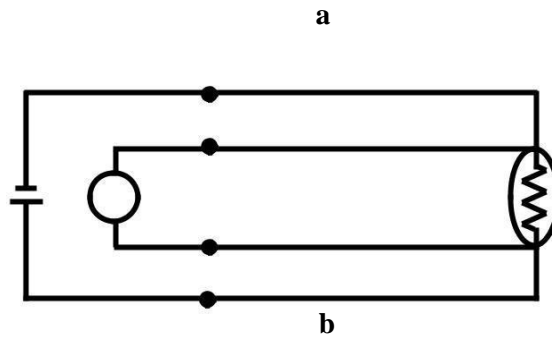

Fig. 3(b) Four wire RTD a, b, c: lead wires

### Thermistor

Thermistors are semiconductor type resistance thermometers. They have very high sensitivity but highly nonlinear characteristics. This can be understood from the fact that for a typical  $2000\ \Omega$  the resistance change at  $25^\circ\text{C}$  is  $80\ \Omega/^\circ\text{C}$ , whereas for a  $2000\ \Omega$  platinum RTD the change in resistance at  $25^\circ\text{C}$  is  $7\ \Omega/^\circ\text{C}$ . Thermistors can be of two types: (a) Negative temperature co-efficient (NTC) thermistors and (b) Positive temperature co-efficient (PTC) thermistors. Their resistance-temperature characteristics are shown in fig. 4(a) and 4(b) respectively.

The NTC thermistors, whose characteristics are shown in fig. 4(a) is more common. Essentially, they are made from oxides of iron, manganese, magnesium etc. Their characteristics can be expressed as:



where,

$R_T$  is the resistance at temperature  $T$  (K)

$R_0$  is the resistance at temperature  $T_0$  (K)

$T_0$  is the reference temperature, normally  $25^\circ\text{C}$

$\beta$  is a constant, its value is decided by the characteristics of the material, the nominal value is taken as 4000.

From (3), the resistance temperature co-efficient can be obtained as:

$$\alpha_T = \frac{1}{R_T} \frac{dR_T}{dT} = -\frac{\beta}{T^2} \quad (4)$$

It is clear from the above expression that the negative sign of  $\alpha_T$  indicates the negative resistance-temperature characteristics of the NTC thermistor.

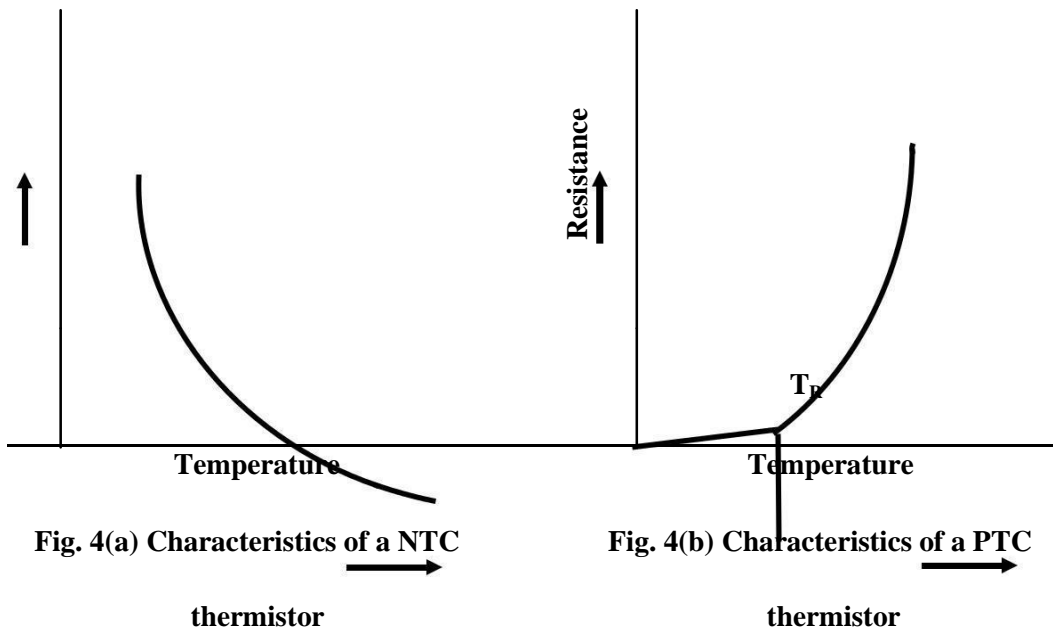

---

Useful range of thermistors is normally  $-100$  to  $+300^{\circ}\text{C}$ . A single thermistor is not suitable for the whole range of measurement. Moreover, existing thermistors are not interchangeable. There is a marked spread in nominal resistance and the temperature coefficient between two thermistors of same type. So, if a defective thermistor is to be replaced by a new thermistor similar type, a fresh

calibration has to be carried out before use. Commercially available thermistors have nominal values of 1K, 2K, 10K, 20K, 100K etc. The nominal values indicate the resistance value at  $25^{\circ}\text{C}$ . Thermistors are available in different forms: bead type, rod type disc type etc. The small size of the sensing element makes it suitable for measurement of temperature at a point. The time constant is also very small due to the small thermal mass involved.

The nonlinear negative temperature characteristics also give rise to error due to *self-heating*

*effect*. When current is flowing through the thermistor, the heat generated due to the  $I^2 R$  -loss may increase the temperature of the resistance element, which may further decrease the resistance and increase the current further. This effect, if not tackled properly, may damage the thermistor permanently. Essentially, the current flowing should be restricted below the specified value to prevent this damage. Alternatively, the thermistor may be excited by a constant current source.

The nonlinear characteristics of thermistors often creates problem for temperature measurement, and it is often desired to linearise the thermistor characteristics. This can be done by adding one fixed resistance parallel to the thermistor. The resistance temperature characteristics of the equivalent resistance would be more linear, but at the cost of sensitivity.

The Positive Temperature Coefficient (PTC) thermistor have limited use and they are particularly used for protection of motor and transformer windings. As shown in fig. 4(b), they have low and relatively constant resistance below a threshold temperature  $T_R$ , beyond which the resistance increases rapidly. The PTC thermistors are made from compound of barium, lead and strontium titanate.

---

## LVDT

The LVDT (Linear Variable Differential Transformer) is an electromagnetic device that produces an electrical voltage proportional to the displacement of a movable Magnetic Core

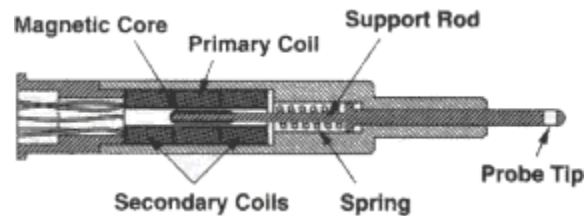
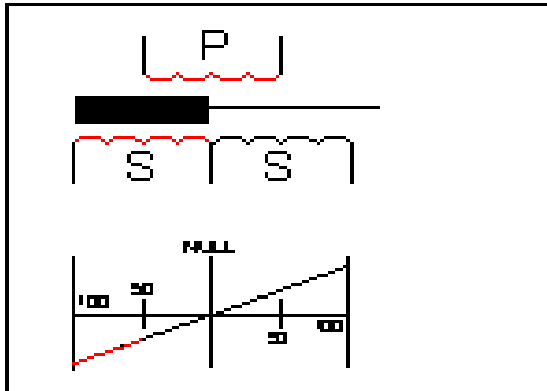

- 1.A COIL WINDING ASSEMBLY consisting of a Primary Coil and two Secondary Coils symmetrically spaced on a tubular center.
- 2.A CYLINDRICAL CASE which encloses and protects the Coil Winding Assembly.
- 3.A rod shaped MAGNETIC CORE which is free to move axially within the Coil Winding Assembly.

separate shield is used for ELECTROMAGNETIC SHIELDING.

### Applications:

Automotive Applications

Industrial Gauging

Machine Tools

Military and Commercial Aircraft

Materials Testing Equipment

---

## Principle of Operation

When an AC excitation signal is applied to the Primary Coil (P), voltages are induced in the two Secondary Coils (S). The MAGNETIC CORE inside the COIL WINDING ASSEMBLY provides the magnetic flux path linking the Primary and secondary Coils.

Since the two voltages are of opposite polarity, the Secondary Coils are connected series opposing in the center, or Null Position. The output voltages are equal and opposite in polarity and, therefore, the output voltage is zero. The Null Position of an LVDT is extremely stable and repeatable.

When the MAGNETIC CORE is displaced from the Null Position, an electromagnetic imbalance occurs. This imbalance generates a differential AC output voltage across the Secondary Coils which is linearly proportional to the direction and magnitude of the displacement.

As shown in the figure, when the MAGNETIC CORE is moved from the Null Position, the induced voltage in the Secondary Coil, toward which the Core is moved, increases while the induced voltage in the opposite Secondary Coil decreases.

LVDTs possess the inherent ruggedness and durability of a transformer and truly provide infinite resolution in all types of environments. As a result of the superior reliability and accuracy of LVDTs, they are the ideal choice for linear motion control.

## General Specifications

### DS6000A LVDT from Daytronic

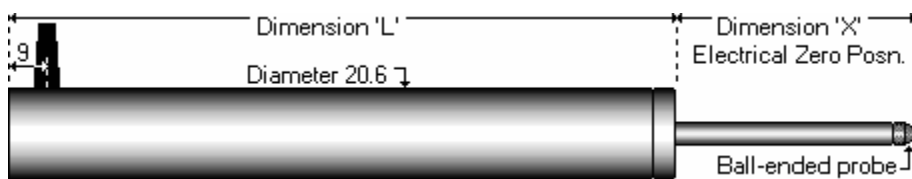

Nominal Stroke mm (in)	"L" mm (in)	"X" mm (in)	Approx. Weight gms (ozs)	Spring Rate* gms/cm (ozs/in)	Electrical Output volts/volt
---------------------------	----------------	----------------	-----------------------------	------------------------------------	------------------------------------

$\pm 75$ ( $\pm 3.0$ )	387 (15.25)	114 (4.5)	483 (17.0)	39 (3.5)	1.5
---------------------------	----------------	--------------	---------------	-------------	-----

## HOT WIRE ANEMOMETER

### Basic Principle of Hot wire Anemometer

When an electrically heated wire is placed in a flowing gas stream, heat is transferred from the wire to the gas and hence the temperature of the wire reduces, and due to this, the resistance of the wire also changes. This change in resistance of the wire becomes a measure of flow rate

## Hot Wire Anemometer

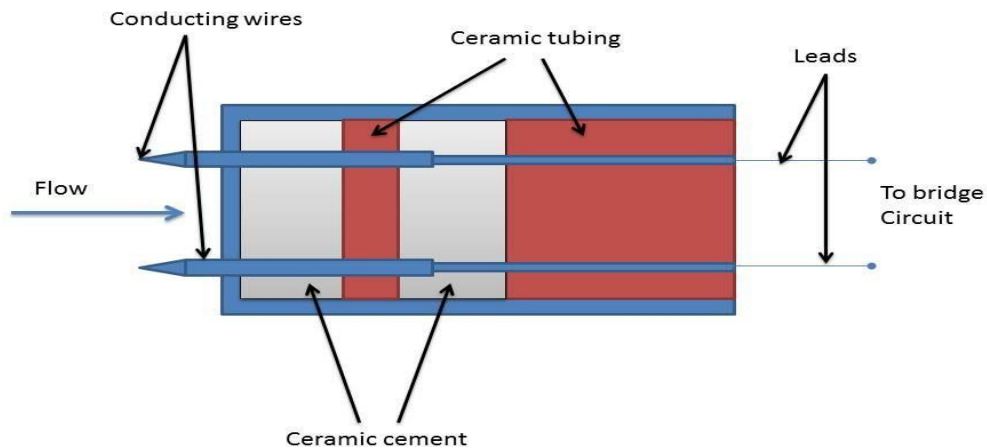

### Description of Hot wire Anemometer

The main parts of the arrangement are as follows: Conducting wires placed in a ceramic body.

- Leads are taken from the conducting wires and they are connected to one of the limbs of the wheat stone bridge to enable the measurement of change in resistance of the wire

### Operation of Hot wire Anemometer

There are two methods of measuring flow rate using a anemometer bridge combination namely:

- Constant current method

- Constant temperature method

### Constant current method

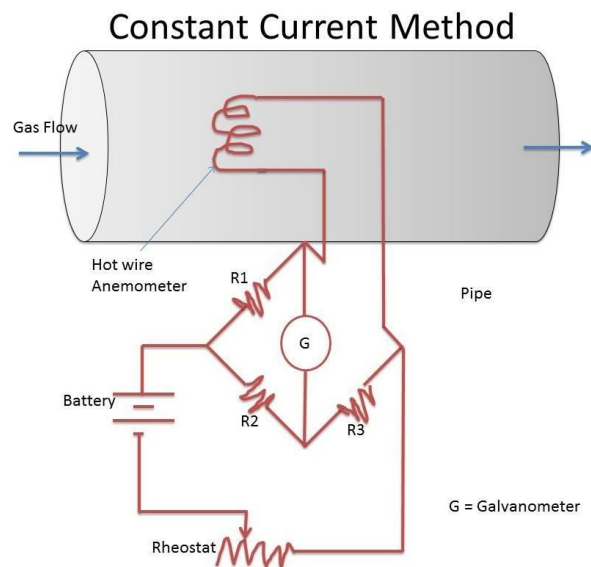

- The bridge arrangement along with the anemometer has been shown in diagram. The anemometer is kept in the flowing gas stream to measure flow rate.
- A constant current is passed through the sensing wire. That is, the voltage across the bridge circuit is kept constant, that is, not varied.
- Due to the gas flow, heat transfer takes place from the sensing wire to the flowing gas and hence the temperature of the sensing wire reduces causing a change in the resistance of the sensing wire. (this change in resistance becomes a measure of flow rate)
- Due to this, the galvanometer which was initially at zero position deflects and this deflection of the galvanometer becomes a measure of flow rate of the gas when calibrated

### Constant temperature method

## Constant Temperature Method

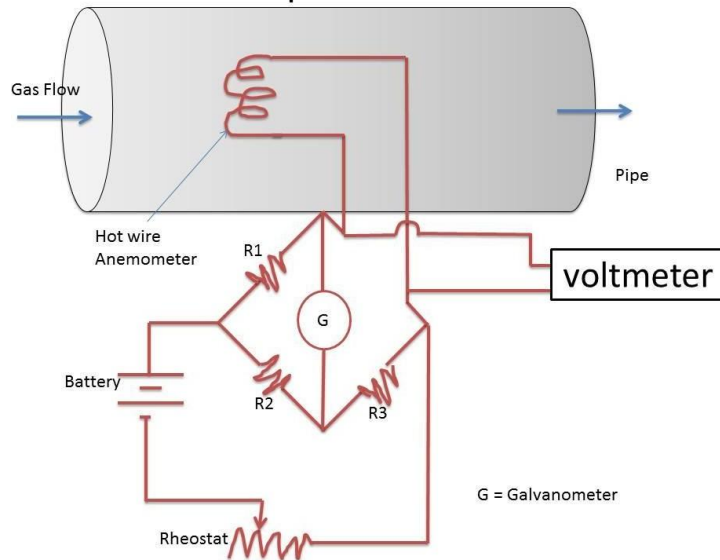

- The bridge arrangement along with the anemometer has been shown in diagram. The anemometer is kept in the flowing gas stream to measure flow rate.
- A current is initially passed through the wire.
- Due to the gas flow, heat transfer takes place from the sensing wire to the flowing gas and this tends to change the temperature and hence the resistance of the wire.
- The principle in this method is to maintain the temperature and resistance of the sensing wire at a constant level. Therefore, the current through the sensing wire is increased to bring the sensing wire to have its initial resistance and temperature.
- The electrical current required in bringing back the resistance and hence the temperature of the wire to its initial condition becomes a measure of flow rate of the gas when calibrated.

## THERMOCOUPLES

### *Principle of Thermocouples:*

When two dissimilar metals such as iron and copper are joined to form a closed circuit, current flows when one junction is at a high temperature and the other one is at a low temperature as shown in the figure.

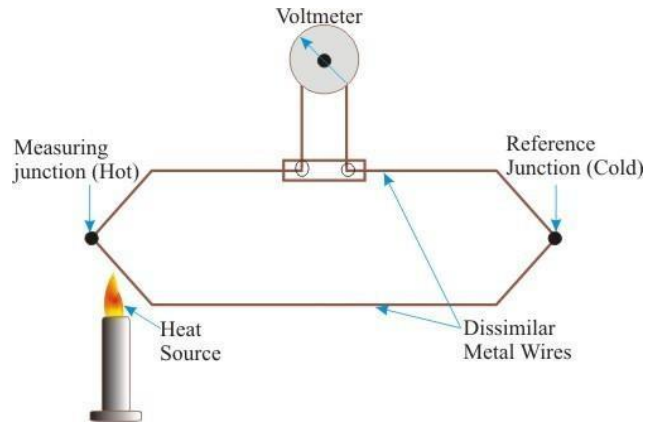

**Figure:** Principle of measurement of temperature by a thermocouple

The emf driving the current is called a thermoelectric emf and the phenomenon is known as thermoelectric effect or Seebeck effect.

Usually a thermoelectric emf is very small. A pair of dissimilar metals welded together at their junction forms what is called a thermocouple. When several thermocouples are arranged in series, the emf is added together to give an appreciable output, this arrangement is called a thermopile as shown in the figure.

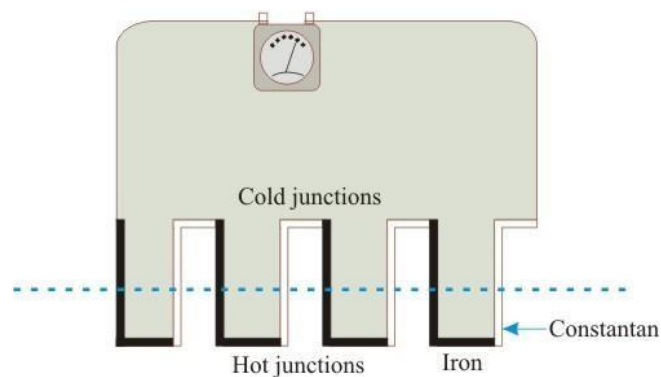

Arrangement of thermocouple to form a thermopile

When two dissimilar metals are joined together, the free electrons move randomly across the junction. Because of the different atomic structure of each metal, electrons pass more readily across the boundary in one direction than in another.



This results in displacement of charges, making one metal positive and the other negative.

**Materials for thermocouple:**

1. Melting point of thermocouple materials must be higher than the measuring temperature.
2. The dissimilar materials on joining should be able to produce large emf for accuracy of measurements.
3. Temperature is determined indirectly i.e. through calibrations of emf with temperature. As far as possible, the linear variation of emf with temperature is desired.
4. Thermocouple materials should be resistant to atmospheres in furnaces. Available thermocouples.

Type	Positive wire (+ve)	Negative wire (-ve)	Maximum temperature (°C)	Suitable under
T	Cu	Ni <sub>45</sub> Cu <sub>55</sub>	370°C	Oxidizing & reducing
S	Pt <sub>90</sub> Rh <sub>10</sub>	Pt	1700°C	Oxidizing & inert
N	Ni <sub>85</sub> Cr <sub>14</sub> Si <sub>1.5</sub>	Ni <sub>95.5</sub> Si <sub>1.5</sub> Mn <sub>0.4</sub>	1260°C	Oxidizing & inert
K	Ni <sub>90</sub> Cr <sub>10</sub>	Ni <sub>95</sub> Mn <sub>2</sub> At <sub>2</sub> Si <sub>1</sub>	1260°C	Oxidizing & inert
J	Fe	Ni <sub>45</sub> Cu <sub>55</sub>	760°C	Oxidizing and reducing
B	Pr <sub>70</sub> Rh <sub>30</sub>	Pt <sub>94</sub> Rh <sub>6</sub>	1750°C	Oxidizing, inert & vacuum

**Cold junction compensation**

Application of Seebeck effect to thermocouple requires that one end of the junction (cold) must be at constant temperature.

The standard calibration data for all thermocouples are based on 0°C cold junction temperature. In practice it may not be possible to keep cold junction at zero degree temperature. Hence standard data need to be corrected. One way is to add the environmental temperature to the value of temperature determined by thermocouple measurement.

---

In another method, thermistor may be put in the thermo- couple circuit. The voltage drop across thermistor depends on environmental temperature which then compensates for the error.

### ***Compensating wires***

Compensating wires are those wires which are connected from the thermocouple to the temperature indicator.

Compensating wires should have same emf as that of thermocouples.

Compensating wires are color coded.

Positive wire	Color	Thermocouple
Fe	White	Fe- constantan
Ni	Yellow	Chromel- alumel
Cr	Blue	Cu- NI base
Cu	Purple	Chromel constantan
Ni	Orange	Nicrosil / Nisil
Cr		
Ni - Cr - Si		

The negative wires in all thermocouples are red.

### ***Selection of thermocouples***

- 1) Type of furnace; whether batch or continuous and the frequency of measurement.
- 2) Furnace atmosphere: The furnace atmosphere may be oxidizing or reducing, inert or vacuum. Accordingly thermocouples are selected. For example Pt, Pt- Rh can be used in oxidizing and inert atmospheres up to 1480°. Chromel - alumel thermocouples may be used in reducing atmosphere but at low temperatures.
- 3) Response of thermocouple to temperature difference is important. Normally thermocouples are inserted in a ceramic sheath. During temperature measurement, The hot junction of the thermocouple is heated by the transfer of heat from sheath. Also large diameter of wire requires sufficient time for heating.

---

## PIEZOELECTRIC TRANSDUCER

A transducer can be anything which converts one form of energy to another. **Piezoelectric material** is one kind of transducers. We squeeze this material or we apply force or pressure on this material it converts it into electric voltage and this voltage is function of the force or pressure applied to it. The material which behaves in such a way is also known as **piezoelectricsensor**.

The electric voltage produced by **piezoelectric transducer** can be easily measured by voltage measuring instruments, which can be used to measure stresses or forces. The physical quantity like mechanical stress or force cannot be measured directly. Therefore, piezoelectric transducer can be used.

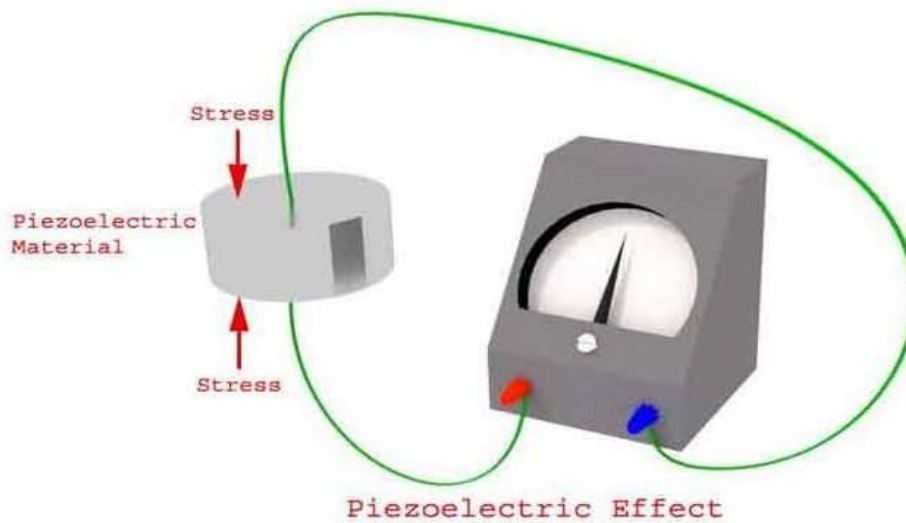

### *Piezoelectric Actuator*

**Piezoelectric actuator** behaves in reverse manner of **piezoelectric sensor**. It is the one in which the electric effect will cause the material to deform i.e. stretch or bend. That means in piezoelectric sensor, when force is applied to stretch or bend it, an electric potential is generated and in opposite when on a **piezoelectric actuator**, an electric potential is applied it is deformed i.e. stretched or bend.

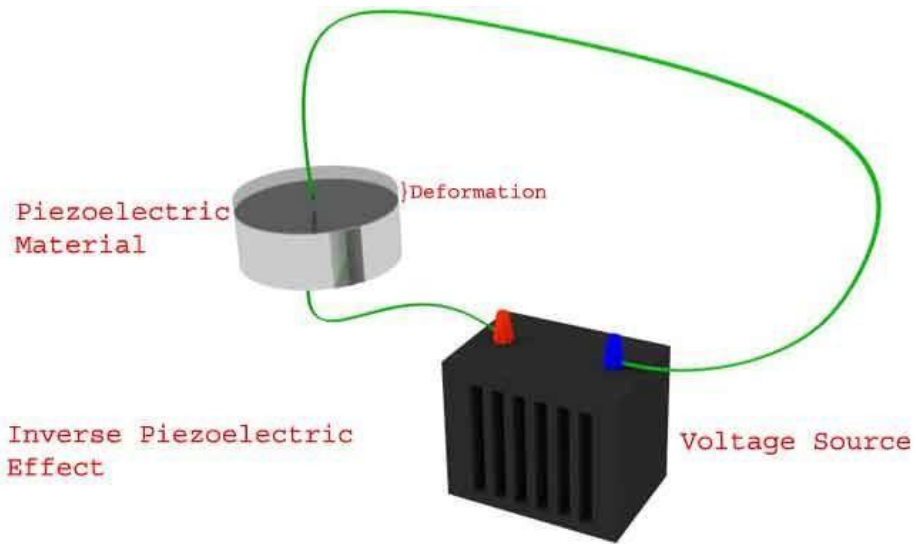

**Piezoelectric transducer** consists of quartz crystal which is made from silicon and oxygen arranged in crystalline structure ( $\text{SiO}_2$ ). Generally, unit cell (basic repeating unit) of all crystal is symmetrical but in piezoelectric quartz crystal it is not. Piezoelectric crystals are electrically neutral. The atoms inside them may not be symmetrically arranged but their electrical charges are balanced means positive charges cancel out negative charge. The quartz crystal has unique property of generating electrical polarity when mechanical stress applied on it along certain plane. Basically, There are two types of stress. One is compressive stress and other is tensile stress.

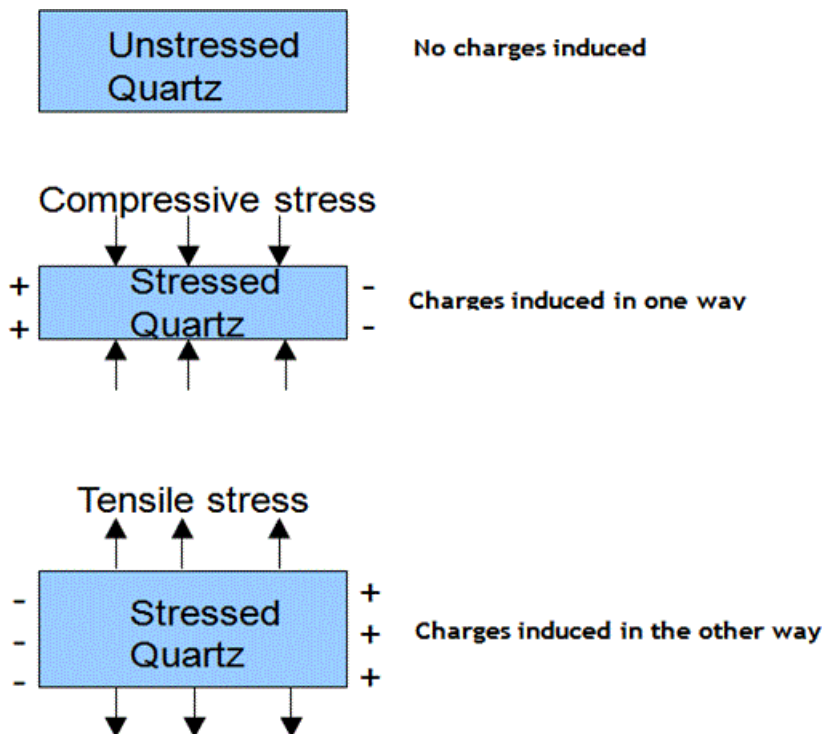

---

When there is unstressed quartz no charges induce on it. In case of compressive stress, positive charges are induced in one side and negative charges are induced in opposite side. The crystal size gets thinner and longer due to compressive stress. In case of tensile stress, charges are induced in reverse as compare to compressive stress and quartz crystal gets shorter and fatter.

**Piezoelectric transducer** is based on principle of piezoelectric effect. The word piezoelectric is derived from Greek word piezen, which means to squeeze or press. Piezoelectric effect states that when mechanical stress or forces are applied on quartz crystal, produce electrical charges on quartz crystal surface. The piezoelectric effect is discovered by Pierre and Jacques curie. The rate of charge produced will be proportional to rate of change of mechanical stress applied on it. Higher will be stress higher will be voltage. One of the unique characteristics of piezoelectric effect is that it is reversible means when voltage is applied to them ,they tends to change dimension along certain plane i.e quartz crystal structure is placed into electric field, it will deform quartz crystal by amount proportional to strength of electric field. If same structure is placed into an electric field with direction of field reversed, the deformation will be opposite.

Quartz crystal becomes shorter due to electric field applied in reversed direction. It is self-generating transducer. It does not require electric voltage source for operation. The electric voltage produced by piezoelectric transduce is linearly varies to applied stress or force. **Piezoelectric transducer** has high sensitivity. So, it acts as sensor and used in accelero meter due to its excellent frequency of response. The piezoelectric effect is used in many application that involve production and detection of sound, electronic frequency generation. It acts as ignition source for cigarette lighter and used in sonar, microphone, force, pressure and displacement measurement

### **Application of Piezoelectric Materials?**

1. In microphones, the sound pressure is converted into electric signal and this signal is ultimately amplified to produce louder sound.
2. Automobile seat belts lock in response to a rapid deceleration is also done by piezoelectric material.
3. It is also used in medical diagnostics.
4. It is used in electric lighter used in kitchens. Pressure made on piezoelectric sensor creates anelectric signal which ultimately causes flash to fire up.
5. They are used for studying high speed shock waves and blast waves.
6. Used in fertility treatment.
7. Used in Inkjet printers

- 
8. It is also used in restaurants or airports where when a person steps near the door and the door opens automatically. In this the concept used is when person is near the door a pressure is exerted persons weight on the sensors due to which the electric effect is produced and the door opens automatically.

### **Examples of Piezoelectric Material**

The materials are :

1. Barium Titanate.
2. Lead zirconate titanate (PZT).
3. Rochelle salt.

### **The Piezoelectric Ultrasonic Transducer**

It produces frequencies which are far above than that which can be hear by human ear. It expands and contracts rapidly when subjected to any voltage. It is typically used in vaccum cleaner.

### **Piezo Buzzer**

Buzzer is anything which produces sound. They are driven by oscillating electronic circuit.

### **Advantages of Piezoelectric Transducer**

1. No need of external force.
2. Easy to handle and use as it has small dimensions.
3. High frequency response it means the parameters change very rapidly.

### **Disadvantages of Piezoelectric Transducer**

1. It is not suitable for measurement in static condition.
2. It is affected by temperatures .
3. Output is low so some external circuit is attached to it.
4. It is very difficult to give desired shape to this material and also desired strength.

---

## VARIABLE CAPCITANCE TRANSDUCER

### *Principle:*

The principle of variable capacitance is used in displacement measuring transducers in various ways. Capacitance is a function of effective area of conductor, the separation between the conductors and the dielectric strength of the material. It is described in the equation below:

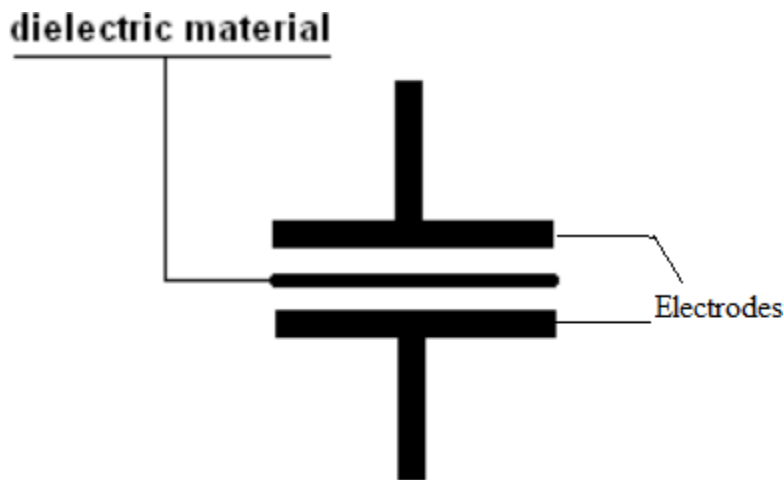

$$C = \frac{\epsilon A}{d}$$

**d**-Distance between the two parallel electrodes.  
**ε** - Dielectric constant, permittivity, of the dielectric medium  
**A** - Area of the electrode.

### *Working:*

There are three way to change the capacitance, changing in the area, changing the distance between the electrode plates and changing the material between the electrodes thus permittivity changes.

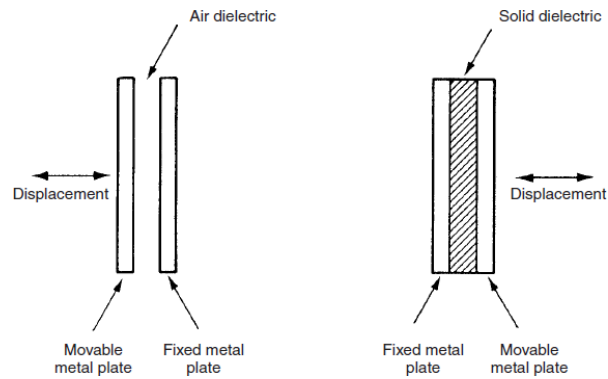

One of the two electrodes is made fixed and the other is made movable for measure displacement. Displacement to be measured is applied to the movable metal plate, as the plate moves the distance between the plates increases and this changes the capacitance measurement. Thus the change in the capacitance will be the function of the displacement of the electrode.

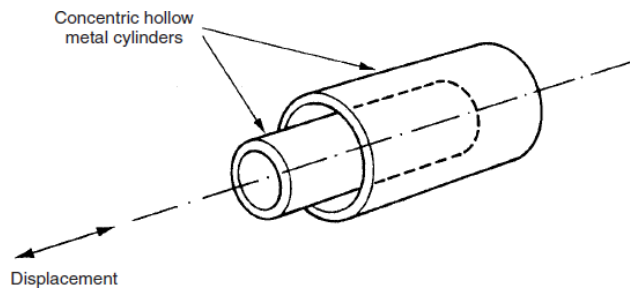

The capacitor plates are formed by two concentric, hollow, metal cylinders. The displacement to be measured is applied to the inner cylinder, which alters the capacitance.

**Example: capacitance transducer for Level measurement:**

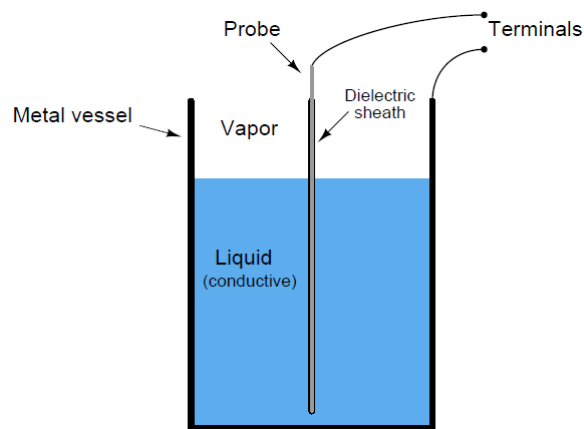



---

Here both the electrodes are fixed so the distance is constant. One electrode is dipped into the liquid and another one is fixed to the wall of the tank. As the liquid level increases the permittivity changes and thus the capacitance changes.

**Advantages:**

- It produces an accurate frequency response to both static and dynamic measurements
- Negligible loading effects

**Disadvantage:**

- Accuracy can be affected by change in temperature
- As the lead is lengthy it can cause errors or distortion in signals

## **MAGNETOSTRICTIVE TRANSDUCERS**

### **Magnetostriction**

Magnetostriction can be explained as the corresponding change in length per unit length produced as a result of magnetization. The material should be magnetostrictive in nature. This phenomenon is known as Magnetostrictive Effect. The same effect can be reversed in the sense that, if an external force is applied on a magnetostrictive material, there will be a proportional change in the magnetic state of the material. This property was first discovered by James Prescott Joule by noticing the change in length of the material according to the change in magnetization. He called the phenomenon as Joule effect. The reverse process is called Villari Effect or Magnetostrictive effect. This effect explains the change in magnetization of a material due to the force applied. Joule effect is commonly applied in magnetostrictive actuators and Villari effect is applied in magnetostrictive sensors.

This process is highly applicable as a transducer as the magnetostriction property of a material does not degrade with time.

### **Magnetostriction Transducers**

A magnetostriction transducer is a device that is used to convert mechanical energy into magnetic energy and vice versa. Such a device can be used as a sensor and also for actuation as the **transducer** characteristics is very high due to the bi-directional coupling between mechanical and magnetic states of the material.

This device can also be called as an electro-magneto mechanical device as the electrical conversion to its appropriate mechanical energy is done by the device itself. In other devices, this operation is carried out by passing a current into a wire conductor so as to produce a magnetic field or measuring current induced by a magnetic field to sense the magnetic field strength.

### Working

The figure below describes the exact working of a magnetostrictive transducer. The different figures explain the amount of strain produced from null magnetization to full magnetization. The device is divided into discrete mechanical and magnetic attributes that are coupled in their effect on the magnetostrictive core strain and magnetic induction.

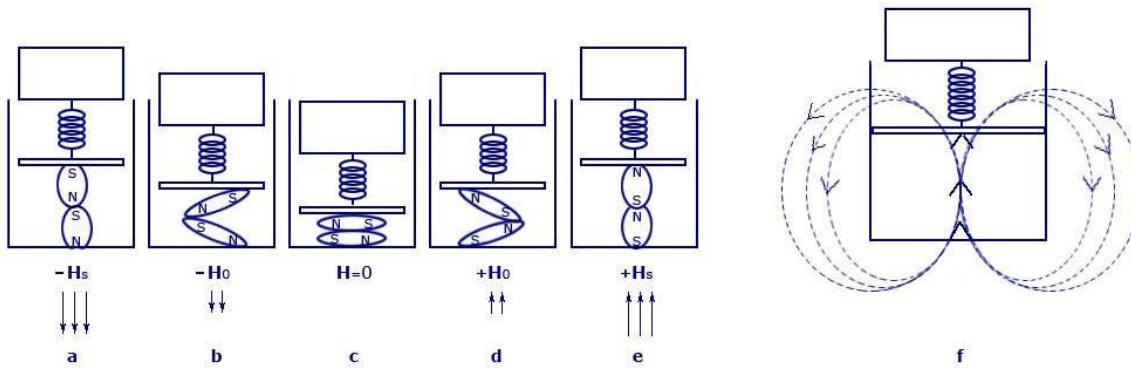

Magnetostrictive Transducers

www.InstrumentationToday.com

### Magnetostrictive Transducers

First, considering the case where no magnetic field is applied to the material. This is shown in fig.c. Thus, the change in length will also be null along with the magnetic induction produced. The amount of the magnetic field (H) is increased to its saturation limits ( $\pm H_{sat}$ ). This causes an increase in the axial strain to  $-e_{sat}l$ . Also, there will be an increase in the value of the magnetization to the value  $+B_{sat}$  (fig.e) or decreases to  $-B_{sat}$  (fig.a). The maximum strain saturation and magnetic induction is obtained at the point when the value of  $H_s$  is at its maximum. At this point, even if we try to increase the value of field, it will not bring any change in the value of magnetization or field to the device. Thus, when the field value hits saturation, the values of strain and magnetic induction will increase moving from the center figure outward.

Let us consider another instance, where the value of  $H_s$  is kept fixed. At the same time, if we increase the amount of force on the magnetostrictive material, the compressive stress in the material will increase on to the opposite side along with a reduction in the values of axial strain and axial magnetization.

---

In fig.c, there are no flux lines present due to null magnetization. Fig.b and fig.d has magnetic flux lines in a much lesser magnitude, but according to the alignment of the magnetic domains in the magnetostrictive driver. Fig.a also has flux lines in the same design, but its flow will be in the opposite direction. Fig.f shows the flux lines according to the applied field  $H_s$  and the placing of the magnetic domains. These flux fields produced are measured using the principle of Hall Effect or by calculating the voltage produced in a conductor kept in right angle to the flux produced. This value will be proportional to the input strain or force.

## Applications

The applications of this device can be divided into two modes. That is, one implying Joule Effect and the other are Villari Effect.

- In the case where magnetic energy is converted to mechanical energy it can be used for producing force in the case of actuators and can be used for detecting magnetic field in the case of sensors.
- If mechanical energy is converted to magnetic energy it can be used for detecting force or motion.
- In early days, this device was used in applications like torque meters, sonar scanning devices, hydrophones, telephone receivers, and so on. Nowadays, with the invent of –giantll magnetostrictive alloys, it is being used in making devices like high force linear motors, positioners for adaptive optics, active vibration or noise control systems, medical and industrial ultrasonic, pumps, and so on. Ultrasonic magnetostrictive transducers have also been developed for making surgical tools, underwater sonar, and chemical and material processing.

---

## **FLOW MEASUREMENT**

Flow measurement can be defined as the quantification of movement of a fluid. The flow measurement is assumed as the oldest recorded work in the instrumentation field. In industrial field, flow measurement is of great importance as from physiological processes to rocket science, the characteristic of flow is required. Its applications also extends to measurements in day to day processes like gas stations, water service, and so on

Generally flow is measured in two ways , volumetric basis and on the basis of weight .The flow of solids are usually measured in terms of mass per unit time or weight per unit time. Liquid flow is measured volumetrically or in the basis of weight. Gaseous flow is normally measured volumetrically.

When we are dealing with flow meters there are two terms called ‘\_turn down’ and ‘\_rangeability’. Turn down is defined as the ratio of full-scale flow to the minimum flow, which can be measured within a stated accuracy. If the turn down is in the ratio of 20:1, it means that the flow meter can measure from 20 per cent to 100 percent of the scale. This gives the accuracy of the meter. Rangeability is the ratio of maximum to minimum range to which the meter can be calibrated

There are many techniques used for flow measurement. Let us now look at some of the flow meters used in the industry.

### **1) Mechanical type flow meters**

- **Piston Meters**

Piston meters or the rotary piston is semi positive displacement meter consists of a rotating piston in a chamber whose volume is known. They are used for domestic water measurement

- **Variable area meter**

The variable area meter or the rotameter is available for a wide range of liquids but are commonly used for measurement of air and water

- **Turbine flow meter**

The turbine flow meter converts the rotating of the turbine into a human readable scale and to the display

- **Single jet meter**

---

It consists of an impeller with radial vanes which is impinged with a single jet

- **Woltmann meter**

A rotor and helical blades are inserted axially into the flow in a Woltmann meter . it is considered as a turbine flow meter

- **Paddle wheel meter**

Similar to single jet meter except the fact that the impeller will be small .

- **Current meter**

It is used to determine the flow through a large structure like a penstock in a hydro electric plant . the measurement is done by averaging the flow velocity over a large area

- **Nutating disc meter**

Here a nutating disc which is ergonomically mounted is used to determine the fluid flow. Nutating disc meter is usually used in the measurement of water supply

- **Pelton wheel**

A pelton wheel turbine which is also known as the radial turbine converts the mechanical action of the pelton wheel rotating in a liquid to user readable form

- **Multiple jet meter**

Multiple jet meter is a velocity type meter which works similar to a single jet meter except the fact that here the flow is directed equally to the impeller by the ports

- **Oval gear meter**

it is a positive displacement meter which is used to measure the flow

- **Inferential meter**

Inferential meter reduces the volumetric flow by measuring some properties of the liquid

---

## **2) Pressure based flow meters**

- Orifice plate
- Venturi meter
- Dall tube
- Pitot tube
- Multi hole pressure probe
- Differential pressure transmitters

## **3) Optical flow meters**

## **4) Open channel flow measurement**

- Level to flow measurement
- Area/velocity measurement
- Dye testing
- Acoustic Doppler velocimetry
- 

## **5) Thermal flow meters**

## **6) vortex**

## **7) Electromagnetic flow meters**

## **8) Ultrasonic flow meters**

## **9) mass flow meters**

Angular momentum mass flow meter –

- Corioles mass flow meters
- Thermal mass flow

## **10) Laser Doppler flow measurement**

### **Calibration of flow meters**

Flow meters are considered to be pretty accurate and in ideal case they are not affected by its environmental conditions. But in practical case we have to consider various environmental factors

---

too. We can see that due to improper installation and other factors industrial flow measurements are often prone to errors for avoiding these errors we have to calibrate the flow meters. Usually in situ methods are employed for calibrating flow meters.

### **How to Select a Flow meter**

You know a flow meter is an instrument used by measure the linear or non linear mass flow rate in gases or liquids. Flow meters are classified into different basis according to the method used to measure the rate of flow. All these types of flow meters have their own merits and demerits. For selecting the best flow meter we must consider many aspects like the process conditions, turndown requirements, accuracy, installation requirement and so on. We are giving some guide lines which will help you to select the best flow meter for your requirement

1. First enquire about the type of flowmeter which has been used in similar application before. This is the simple and most popular method. There are many manufactures around the planet making flow meters are they will be having websites. In the product specifications they will be mentioning its applications.
2. Another option is using the most familiar type of flow meter such as the differential pressure flow meter. We will not recommend this as it's not a much accurate option. You should do further check before finalizing the flow meter.
3. Some other factors according to which flow meters are chosen are based on service, rangeability, pressure loss, accuracy, installation requirements, cost.
4. Special attention should be taken for flowmeter intended to be used on sour service applications. NACE requirements, testing requirements etc should be carefully considered.
5. When choosing flow meters employed in hazardous area requirements, winterization requirements etc all requirements should be full filled .
6. Special service applications such as custody transfer metering , multiphase flow metering etc. needs specific types of flowmeters in order to suit their requirements and hence the same shall be carefully considered.
7. The installation requirements of the corresponding flow meter should be satisfied, as the piping layouts can be affected by straight run requirements of flowmeters.

### **Displacement Transducers**

Displacement is a basic variable whose value is measured and involved in many other physical parameters such as velocity, force, acceleration, torque and so on. The transducer used for the

---

measurement of displacement can be classified in many ways. One of the most common classification is given below.

- Mechanical
- Pneumatic
- Electrical
- Optical

In order to obtain an electrical output, a mixture of two or more methods is also used. For example, optical methods using photo-detectors present the output as an electrical quantity like voltage, current and so on. Thus, the combined mechanical and optical method is desired.

Measurements can be made in the direct and indirect way. In direct method, the displacement is measured directly. But indirect methods are mostly used as the associated variables like force, acceleration, torque, velocity and so on can be obtained.

In electrical conversion method, the displacement is converted to an electrical quantity like voltage or current. This value is then recorded or displayed on a screen.

A basic displacement scheme is shown in the figure below.

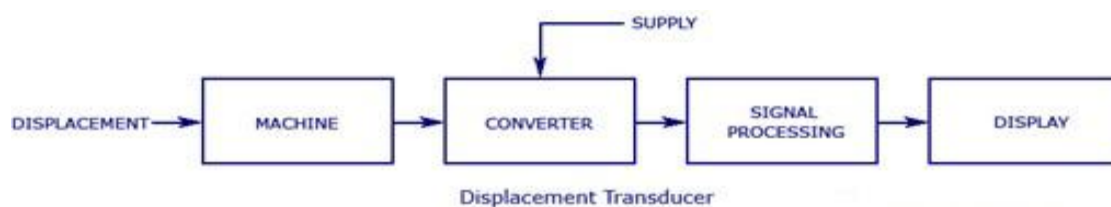

Displacement Transducer

Some of the most commonly used methods are listed and explained below. Though some of these methods can be used for the measurement of other physical quantities, the electrical signals derived from such transducers always depend on a displacement parameter.

## **LIQUID LEVEL AND HUMIDITY**

### Capacitive level sensing

Concept of capacitance - A capacitor is formed by two electrodes electrically insulated from each other the electrodes themselves must be conductive and typically made from metal. They can be any shape the two parallel plates are easiest to visualize. The capacitors have the ability to store energy in



an electric field between its electrodes caused when a voltage or potential is applied to the circuit. The property of capacitance relates the amount of energy stored in this field to the applied potential. By placing non conductive material between the electrodes the ability for the capacitor to store energy increases and so the capacitance increases. This material between the electrodes referred to as the dielectric. The key property of dielectric material is known variously as dielectric constant or relative permittivity. This property is the amount of charge the material can still define relative to a vacuum and other gases such as fuel vapors have values similar to a vacuum.

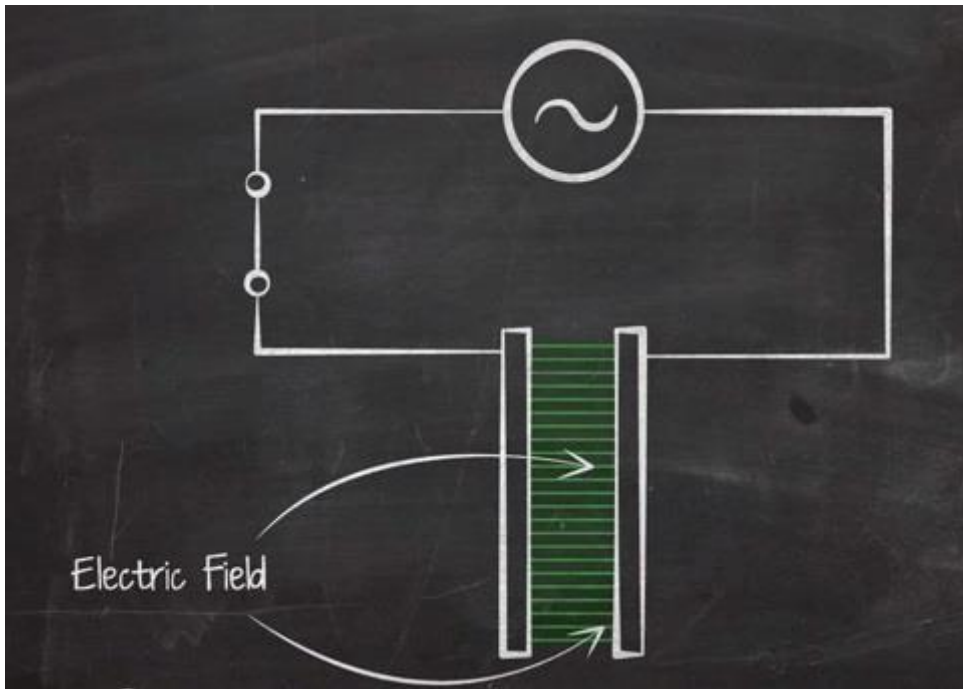

As a dielectric is introduced between the electrodes of the capacitor and capacitance changes progressively and the liquid level can be determined.

To measure variations in capacitance electric energy flowing in to and out of the electrodes is measured as the circuit potential is varied. A regular flow of energy is established by connecting the electrodes to an alternating current measurement circuit. The more energy flow in to the electrodes the greater the capacitance meaning more dielectric between the electrodes.

For sensor calibration reference measurement its empty and full tank condition must be taken. Generally we need to know the dielectric constants of the liquid being measured to calibrate the sensor at its full condition.

---

## Advantages of capacitance level measurement

Inexpensive

reliable

Versatile

Minimal maintenance

Contains no moving parts

Good range of measurement

Rugged

Simple to use

Easy to clean

High temperature and high pressure application

## Disadvantages

Not suitable for low dielectric material

## **HUMIDITY MEASUREMENT**

A humidity sensor (or hygrometer) senses, measures and reports both moisture and air temperature. The ratio of moisture in the air to the highest amount of moisture at a particular air temperature is called relative humidity. Relative humidity becomes an important factor, when looking for comfort.

Humidity sensors work by detecting changes that alter electrical currents or temperature in the air.

There are three basic types of humidity sensors:

1. Capacitive
2. Resistive
3. Thermal

### **Capacitive**

A capacitive humidity sensor measures relative humidity by placing a thin strip of metal oxide between two electrodes. The metal oxide's electrical capacity changes with the atmosphere's relative humidity. Weather, commercial and industries are the major application areas.

The capacitive type sensors are linear and can measure relative humidity from 0% to 100%. The catch here is a complex circuit and regular calibration. However for designers this a lesser hassle over precise measurement and hence these dominate atmospheric and process measurements. These are the

---

only types of full-range relative humidity measuring devices down to 0% relative humidity. This low temperature effect often leads to them being used over wide temperature ranges without active temperature compensation.

### **Resistive**

Resistive humidity sensors utilize ions in salts to measure the electrical impedance of atoms. As humidity changes, so do the resistance of the electrodes on either side of the salt medium.

### **Thermal**

Two thermal sensors conduct electricity based upon the humidity of the surrounding air. One sensor is encased in dry nitrogen while the other measures ambient air. The difference between the two measures the humidity.

## **FORCE AND PRESSURE**

### **Pressure Transducer**

A pressure transducer is used to convert a certain value of pressure into its corresponding mechanical or electrical output. Measurement of pressure is of considerable importance in process industries.

### **Types**

The types of pressure sensors are differentiated according to the amount of differential pressure they are able to measure.

For low differential pressure measurement **Liquid Column Manometers** are used. Elastic type pressure gauges are also used for pressure measurement up to 700 MPa. Some of the common elastic/mechanical types are:

- **Bourdon Tubes**
- **Diaphragm**
- **Piston Type Pressure Transducer**
- **Bellows**

### **Other Types:**

- **Electrical Type Pressure Sensors**
- **Bell Gauge**
- **Manometers**

---

Before going into further details regarding pressure measurement, it is important to know the different terms related to pressure.

### **Basic Terms Related To Pressure Measurement**

- **Pressure**

Pressure is known to be the force that is exerted due to the weights of different gases and liquids. Some common examples are atmospheric pressure and the pressure implied by liquids inside the walls and underside of a container.

Pressure can be measured as the force exerted over a certain area.

$$\textit{Pressure} = \textit{Force}/\textit{Area}$$

Pressure is not an independent variable as it is derived from force and area and it is not ideal as it depends on other factors like elevation, fluid density, temperature, flow velocity, and so on.

In instrumentation analysis, pressure is commonly expressed in pounds per square inch (psi). It can also be expressed in pounds per square feet (psf) and Pascals (Pa). Pascal is the SI unit of pressure. In many cases, pressure is expressed in terms of atmosphere which is the height of the barometric column at zero degrees Celsius, being equal to 76 cm of mercury or equivalent to 14.696 pounds per square inch absolute,  $1 \text{ kg/cm}^2$ . Most of the pressures range from a little below atmosphere to hundreds of atmospheres.

- **Density** is the mass per unit volume of the material. It can be expressed as kilogram per cubic meter. ( $\text{kg/m}^3$ ).
- **Specific Weight** is the weight per unit volume of the material. It can be expressed as Newton per cubic meter ( $\text{N/m}^3$ ).
- **Specific Gravity** is basically a non-dimensional value as it is the ratio of two measurements in the same unit. It can be the ratio between the density of a material and the density of water or even the ratio between the specific weight of a material to the specific weight of water.
- **Static Pressure** is the fluid or gas pressure that does not move.
- **Dynamic Pressure** is the gas or fluid pressure that is obtained when it impacts with a surface or an object due to its motion or flow.
- **Impact Pressure** is the total pressure or the addition of both the static and dynamic pressures.
- **Atmospheric Pressure** is the surface pressure of earth and is available due to the weight of the gases in the earth's atmosphere.

- 
- Another important aspect of pressure measurement is the measurement of very low pressure or what is known as vacuum. With the advancement of scientific research and industrial application of the results, pressure as low as 10<sup>-6</sup> mm of mercury is often required to be measured in some systems. Measurement of pressure, therefore, consists of two parts – that of pressure and vacuum. The force exerted by the fluid per unit area of the wall of the container is called the absolute pressure, whereas the gauge pressure is the difference between the absolute and local atmospheric pressure, and when gauge pressure is negative, it is known as vacuum.

Basic methods of pressure measurement are same as those of force measurement. For high vacuum, however, some special techniques are necessary. Primary sensors are mostly, mechanical which through secondary sensing means provide electrical outputs. Manometers and elastic element sensors are used as primary pressure sensors while secondary sensing, often called transducing here, involves resistive, inductive and capacitive changes for deriving electrical outputs.

### **Pressure Instrument Selection**

Selection of pressure instrument for a particular application must be done carefully, taking into consideration various aspects such as process conditions, turn down requirements, accuracy, installation requirements, and so on.

While selecting a pressure instrument for a particular application, the process data such as fluid phase, pressure, temperature, density and viscosity must be correctly defined for all operating conditions including start-up, emergency operations and design conditions.

Another important parameter for selection is the turn down requirements, based on which we can select the pressure instrument to suit the maximum and minimum conditions within its specified accuracy limits.

In addition to the above, the installation requirements of the selected pressure instrument shall be carefully addressed taking in to account visibility, accessibility, because these requirements may affect the piping layouts.

### **Piston Type Pressure Transducer**

As shown in the figure below, the input pressure is given to the piston. This moves the piston accordingly and causes the spring to be compressed. The piston position will be directly proportional to the amount of input pressure exerted. A meter is placed outside the piston and spring arrangement,

---

which indicates the amount of pressure exerted. As the device has the ability to withstand shock, sudden pressure changes, and vibrations, it is commonly used in hydraulic applications. Mostly, the output of the piston and spring arrangement is given to a secondary device to convert movement into an electrical signal.

### Piston Type Pressure Transducer

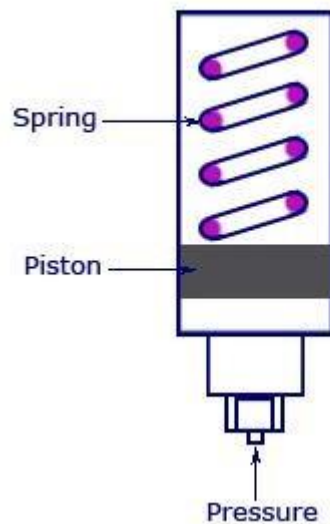

Piston Type Pressure Transducer

### Bell Gauge

The bell gauge is a type of pressure transducer that measures differential pressure between 0.06 Pa and 4 KPa. The static pressure may be as high as 4 to 6 MPa. The schematic diagram of a single element bell gauge is shown below.

## BELL GAUGE

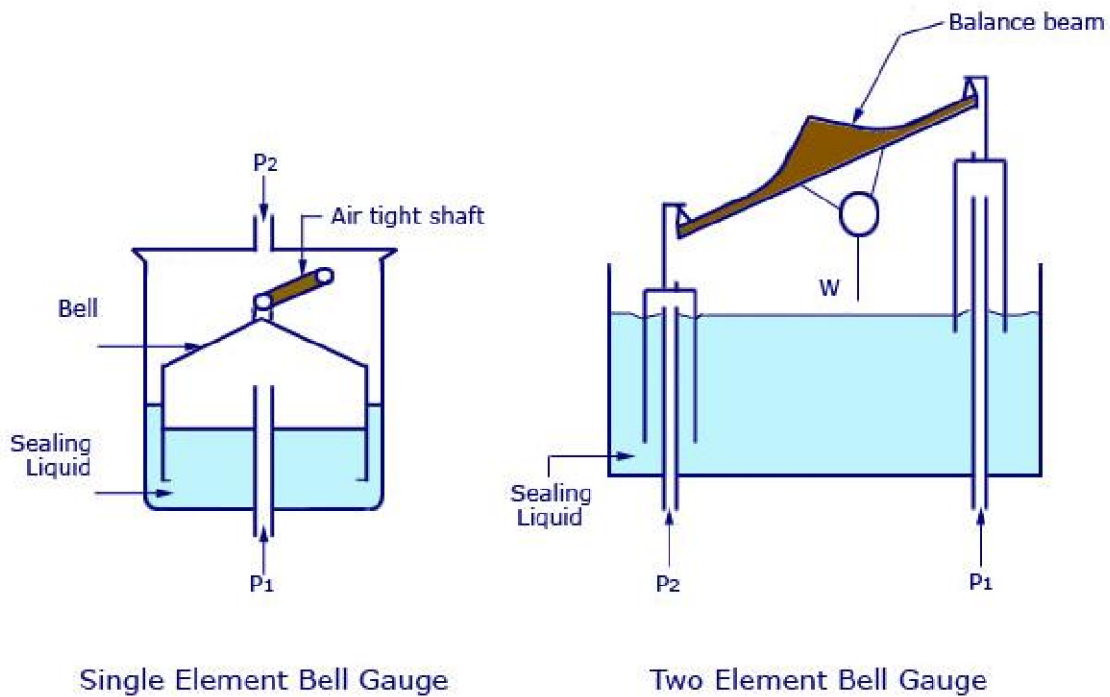

### Bell Gauge

The movement of the bell is taken out by link and lever mechanism or by some electrical methods. When the bell moves maximum up or down it closes the inlets of pressure  $p_2$  or  $p_1$ , whereby protection to overrange and reversal of pressure are afforded. The diagram of a two element bell differential gauge or balance is also shown above. The two identical bells are suspended from the two knife edges of a balance beam. The differential weight is balanced statically by the movement of the counter weight  $w$ .

### Force Transducers

The basic principle behind the measurement of force is – when a force is applied on an object, the object gets displaced. The amount of displacement occurred can be calculated using the various **displacement transducers**, and thus force measurement can be done. This is an indirect method for calculating force. Some of the direct methods for measuring force are given below.

- 
- **Strain Gauge Transducer**
  - **Piezo-Electric Transducer**
  - **Magnetostrictive Transducer**
  - **Force Measurement using Pressure**
  - **Other Force Measuring Systems**

### *Force Measurement Using Pressure*

Force measurement through pressure can be done with two types of load cells. They are explained below.

#### **1. Hydraulic Load Cell**

As shown in the figure given below, the inside chamber of the device is filled with oil which has a pre-load pressure. The force is applied on the upper portion and this increases the pressure of the fluid inside the chamber. This pressure change is measured using a pressure transducer or is displayed on a pressure gauge dial using a Bourdon Tube.

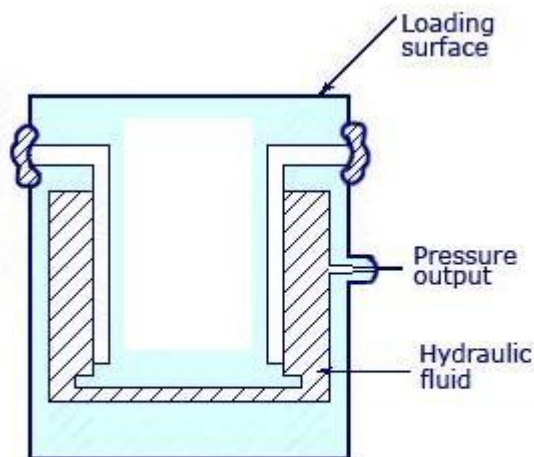

**Hydraulic Load Cell**

#### **Hydraulic Load Cell**

When a pressure transducer is used for measuring the value, the load cell is known to be very stiff. Even at a fully forced condition, it will only deflect up to 0.05mm. Thus, this device is usually used for calculating forces whose value lies between 500N and 200KiloN. The force monitoring device can be placed at a distance far away from the device with the help of a fluid-filled hose. Sometimes there will be need of multiple load cells. If so, a totaliser unit has to be designed for the purpose.



---

The biggest advantage of such a device is that it is completely mechanical. There is no need of any electrical assistance for the device. They can also be used for calculating both tensile and compressive forces. The error percentage does not exceed more than 0.25% if the device is designed correctly.

The device will have to be calibrated according to the temperature in which it is used as it is temperature sensitive.

## 2. Pneumatic Load Cell

The working of a pneumatic load cell is almost same to that of a hydraulic load cell. The force, whose value is to be measured, is applied on one side of a piston and this is balanced by pneumatic pressure on the other side. The pressure thus obtained will be equal to the input force applied. The value is measured using a bourdon tube.

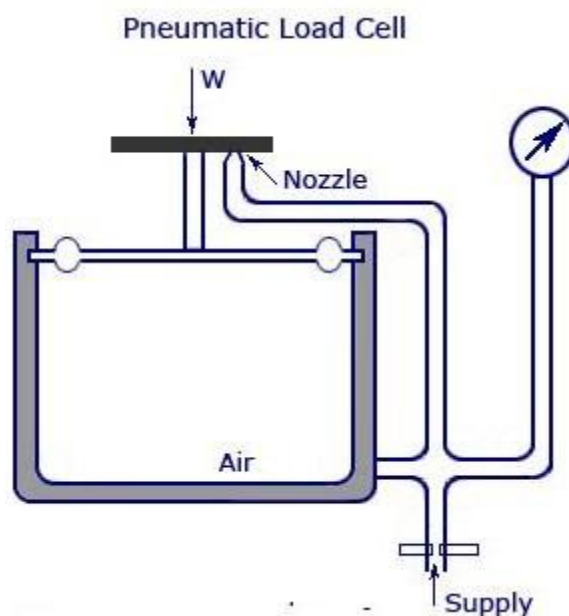

### Pneumatic Load Cell

The pneumatic load cell has an inside chamber which is closed with a cap. An air pressure is built up inside the chamber until its value equals the force on the cap. If the pressure is increased further, the air inside the chamber will forcefully open the cap and the process will continue until both the pressures are equal. At this point, the reading of the pressure in the chamber is taken using a pressure transducer and it will be equal to the input force.

## Velocity Transducer

A velocity transducer/sensor consists of a moving coil suspended in the magnetic field of a permanent magnet. The velocity is given as the input, which causes the movement of the coil in the magnetic field. This causes an emf to be generated in the coil. This induced emf will be proportional to the input velocity and thus, is a measure of the velocity. The instantaneous voltage produced is given by the equation

$$v = N(d\phi/dt)$$

$N$  – Number of turns of the coil

$d\phi/dt$  – Rate of change of flux in the

coil

The voltage produced will be proportional to any type of velocities like linear, sinusoidal or random.

The damping is obtained electrically. Thus, we can assume a very high stability under temperature conditions. The basic arrangement of a velocity sensor is shown below.

### Velocity Transducer Arrangement

The figure shows a moving coil kept under the influence of two pole pieces. The output voltage is taken across the moving coil. The moving coil is kept balanced for a linear motion with the help of a pivot assembly.

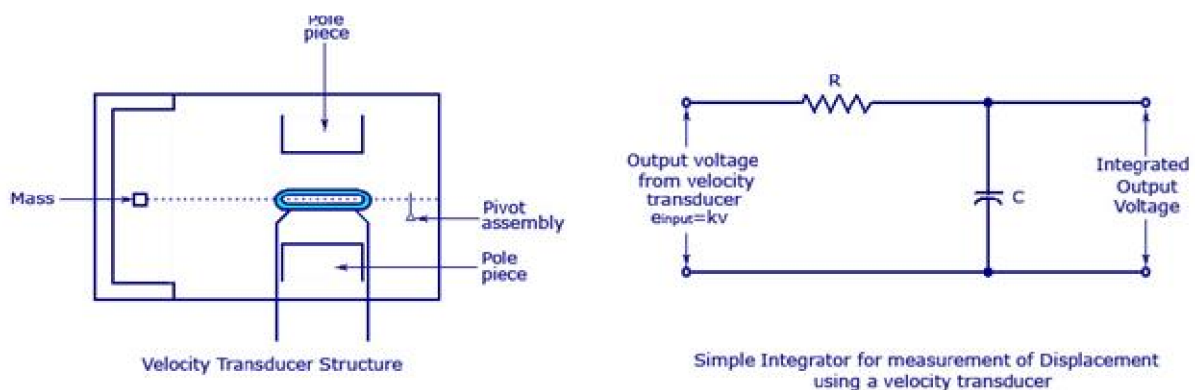

Velocity Transducer

---

## Measurement of Displacement Using Velocity Transducer

We know that velocity is the derivative of displacement with respect to time. Similarly, displacement is the time integral of velocity. Thus, a velocity transducer can be used to find the displacement of an object. All we have to do is add an integrating circuit to the velocity transducer arrangement. The output voltage ( $e_{input}$ ) of the transducer can be represented as the product of a constant  $k$  and the instantaneous velocity  $v$ . If the velocity varies sinusoidally according to its frequency  $f$ , and has a peak value  $V$ , then the output voltage can be written as

$$e_{input} = kV \sin(2\pi ft)$$

$$\text{Capacitor Reactance } X_c = 1/2\pi fc$$

When the value of frequency  $f$  is too low, the value of  $X_c$  will be very large. So, the integrated output voltage,  $e_{output}$  will be proportional to  $e_{input}$  and so will also be proportional to the velocity  $v$ . When the value of frequency becomes high, the value of  $X_c$  will become small. Thus, the integrated output voltage can be written as

$$e_{output} = e_{input} / j\omega CR$$

$$e_{output} = KV / \omega CR \sin(\omega t - 90^\circ)$$

This shows that the value of integrator output lags behind the value of the input voltage by 90 degrees. For a given value of velocity amplitude  $V$ , the integrator output is inversely proportional to frequency  $\omega$ .

## TEMPERATURE MEASUREMENT

### Temperature Sensors

**Transducer** have been devised which produce either changes in voltage or change in impedance whenever the temperature changes. Temperature measurement sensors can be divided into two categories. They are – Measurement using change in resistance and measurement using change in voltage.

The temperature sensor that uses change in resistance to measure temperature is called a resistance thermometer. Resistance thermometer can be further classified into **Resistance Temperature Detectors (RTD)** and **Thermistor**.

---

The temperature sensors that use change in voltage to measure temperature are **Thermocouple** and **Thermopile**

### *Temperature Parameters*

Before going into detail, it is important to know some of the basic temperature parameters and instrumentation systems.

1. **Range:** The range of a temperature measuring device is the maximum and minimum temperature it can indicate, record, measure or transmit. The range should be decided in such a manner that the normal operating temperature is almost (50-70)% of the full scale with the maximum temperature range close to, but more than the upper range of scale.
2. **Span:** The difference between the maximum and minimum values of temperature in the calibrated range is called span. It is always good to have very low values of span. The minimum span is the smallest range that the manufacturer can accurately calibrate within the device's range.
3. **Turndown:** It is the ratio of maximum measurable parameter to minimum measurable parameter.
4. **Immersion Length:** The immersion length of a Thermowell is the distance between the free end/tip of the Thermowell and the point of immersion in the medium that is being measured. The standard symbol for the immersion length of a Thermowell is -R||.
5. **Insertion Length:** The insertion length of a Thermowell is the distance between the free end/tip of a Thermowell and (but not including) the external threads of other means of attachment to a vessel. The standard symbol for the insertion length of a Thermowell is —U||.

### *Temperature*

The term 'temperature' can be defined in terms of heat. Heat is a measure of the energy contained in a body, which is due to the irregular motion of its molecules or atoms. The internal energy of body or gas increases with increasing temperature. Temperature is a variable which together with other parameters such as mass, specific heat etc. describe the energy content of a body. When energy in the form of heat is introduced to or extracted from a body, altered molecular activity will be made apparent as a temperature change.

To measure the value of temperature, some of the following phenomenon is needed.

- Change in physical dimensions or characteristics of liquids, metals, or gases
- Changes in electrical resistance

- 
- Thermoelectric effect
  - Radiant energy

### **Resistance Temperature Detector (RTD)**

A resistance temperature detector (RTD) can also be called a resistance thermometer as the **temperature measurement** will be a measure of the output resistance.

The main principle of operation of an RTD is that when the temperature of an object increases or decreases, the resistance also increases or decreases proportionally. The main difference between a RTD and a **Thermistor** is that the sensing element used in a RTD is a metal and a thermistor uses ceramic or polymer material. As platinum is the most commonly used metal for making RTD's, the device can also be called Platinum Resistance Thermometers (PRT's).

### **RTD Types**

RTD types are broadly classified according to the different sensing elements used. Platinum, Nickel and Copper are the most commonly used sensing elements. Platinum is considered the best as it has the widest temperature range. This is shown in the resistance versus temperature graph below. Platinum type RTD is also known for its best interchange ability than copper and nickel. It also has the highest time stability. PRT's can also be used in unsuitable environments where it can reduce atmospheric metallic vapours and also catalizable vapours if the element is bare. It can also be used in radioactive environments. In industrial applications, a PRT is known to measure temperatures as high as 1500 degree Fahrenheit while copper and Nickel can measure only to a maximum of 400 degree Fahrenheit.

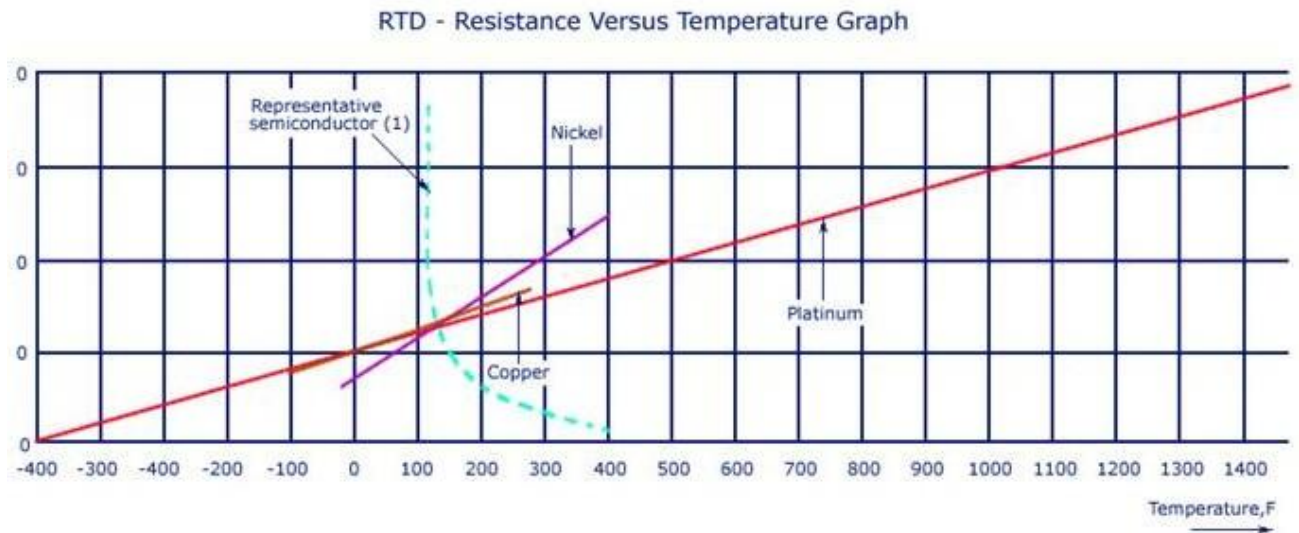

## RTD-Resistance Versus Temperature Graph

### RTD Styles

RTD's are available with single, double, or triple windings, each electrically separated. Use of more than one winding enables two independent measuring circuits to measure the same temperature, and also permits more than one measurement to be made with only one sensor installation. However, the additional mass introduced to the sensor by adding windings and their associated support and encapsulating materials increases both the response time and the conduction error. Using separate sensors provides mechanical independence of the sensors for maintenance.

RTDs should generally be of spring-loaded, tip-sensitive construction, with a 1/4-inch-diameter sheath.

### RTD Wiring Arrangements

RTD's are available with either two, three, or four output wires for connection to the secondary instrument as shown in the figure below. The various wiring arrangements are designed to reduce and/or eliminate any errors introduced due to resistance changes of the lead wires when they also undergo temperature changes. RTDs used for electrical equipment generally use either a three-wire system or a four-wire system having paired lead wires.

Copper lead wires are satisfactory for all the arrangements. For a given RTD, all the lead-wires should be of the same gauge and the same length, and should be run in the same conduit.

The four wire system is little affected by temperature induced resistance changes in lead-wires, and, of all the arrangements, it is affected least by stray currents. It, therefore, is used to measure temperature differences and is used generally for making very accurate measurements. The three-wire system is generally satisfactory for industrial measurement using a secondary instrument that is remote, say, more than 3 meters distant from the RTD. Although the error caused by temperature change in the leads is virtually eliminated in a 3-wire arrangement, a slight non-linearity in the resistance change is introduced with this scheme.

### Resistance Temperature Detector (RTD) - 2-Wire,3-Wire,4-Wire Systems

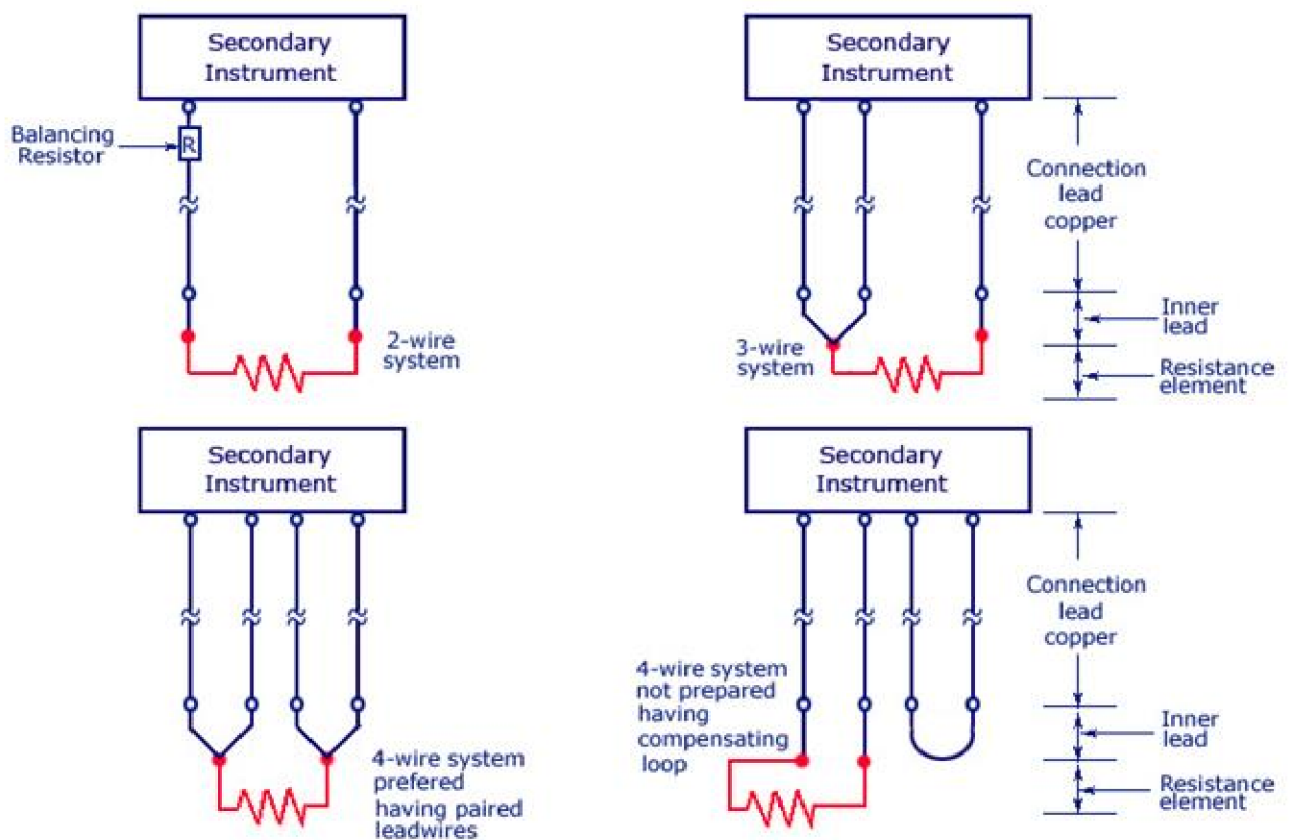

For each arrangement, the secondary instrument measures the resistance of the wires drawn with a heavy line

### Resistance Temperature Detector-(RTD)-2 Wire,3 Wire,4 Wire Systems

#### Power Supply for RTD

An electric dc power supply is required to provide current for the resistance measuring circuit. The power supply is normally applied through the secondary instrument. If the secondary instrument is a



---

transmitter having a current output of (4-20) mA, then the power is carried by the two output wires of the transmitter.

### **RTD Connection Head**

Unless a transmitter is mounted on the **Thermowell**, the sensor should be connected to a connection head generally like that for thermocouples except as follows:

- For a single RTD, the terminal block should be able to handle four lead wires.
- The head shall be explosion proof where and as needed to conform to a hazardous area rating. However, explosion proofing will not be required if the system is intrinsically safe. In this case the thermocouple head should be specified to be weatherproof.

### **RTD Grounding**

The principles for grounding that are stated in —Grounding‖ for **Thermocouples** apply to RTDs, with the exception that the sensitive portion, the resistance wire, of a RTD is never grounded because it must not be shorted. A RTD in a power device, such as a transformer, should be grounded locally; otherwise, RTDs are normally grounded at the power supply. A power supply and all its associated RTDs should be grounded at only one point. If local grounding is required for a RTD, then an individual power supply is required for this RTD.

### **RTD Shielding**

The RTD shielding principle is the same as that of **Thermocouple Shielding**.

### **Transmission of RTD signals**

The transmitter is the most commonly used instrument for transmission of RTD signals. A transmitter may be mounted either on an enclosed rack or locally. A local transmitter may be mounted on a Thermowell and supplied with it as a complete assembly. The most commonly used RTD transmitter is the so-called —Smart‖ transmitter. A typical —Smart‖ temperature transmitter is remarkably versatile: It is suitable for Platinum and Nickel RTDs; 2, 3, or 4 lead wire arrangements; 100, 200, or 500 ohm Platinum sensors, etc. This same instrument can also be used as a thermocouple transmitter, suitable for every thermocouple combination commercially available.

### **Advantages**

- Very high accuracy



- 
- Excellent stability and reproducibility
  - Interchangeability
  - Ability to be matched to close tolerances for temperature difference measurements.
  - Ability to measure narrow spans
  - Suitability for remote measurement

### **Disadvantages**

- Susceptibility to mechanical damage
- Need for lead wire resistance compensation
- Sometimes expensive
- Susceptibility to self-heating error
- Susceptibility to signal noise
- Unsuitability for bare use in electrically conducting substance
- Generally not repairable
- Need for power supply