

LECTURE NOTES

ON

EHV AC Transmission

2019 – 2020

IV B. Tech II semester (IARE-R16)

Ms. P. Sravani, Assistant Professor



ELECTRICAL AND ELECTRONICS ENGINEERING

INSTITUTE OF AERONAUTICAL ENGINEERING

DUNDIGAL, HYDERABAD - 500 043

UNIT-1

Introduction to EHV AC Transmission

1.1 ROLE OF EHV AC TRANSMISSION

Industrial-minded countries of the world require a vast amount of energy of which electrical energy forms a major fraction. There are other types of energy such as oil for transportation and industry, natural gas for domestic and industrial consumption, which form a considerable proportion of the total energy consumption. Thus, electrical energy does not represent the only form in which energy is consumed but an important part nevertheless. It is only 150 years since the invention of the dynamo by Faraday and 120 years since the installation of the first central station by Edison using dc. But the world has already consumed major portion of its natural resources in this short period and is looking for sources of energy other than hydro and thermal to cater for the rapid rate of consumption which is outpacing the discovery of new resources. This will not slow down with time and therefore there exists a need to reduce the rate of annual increase in energy consumption by any intelligent society if resources have to be preserved for posterity. After the end of the Second World War, countries all over the world have become independent and are showing a tremendous rate of industrial development, mostly on the lines of North-American and European countries, the U.S.S.R. and Japan. Therefore, the need for energy is very urgent in these developing countries, and national policies and their relation to other countries are sometimes based on energy requirements, chiefly nuclear. Hydro-electric and coal or oil-fired stations are located very far from load centres for various reasons which requires the transmission of the generated electric power over very long distances. This requires very high voltages for transmission. The very rapid strides taken by development of dc transmission since 1950 is playing a major role in extra-long-distance transmission, complementing or supplementing e.h.v. ac transmission. They have their roles to play and a country must make intelligent assessment of both in order to decide which is best suited for the country's economy.

NECESSITY OF EHVAC TRANSMISSION

- ✓ With the increase in transmission voltage, for same amount of power to be transmitted current in the line decreases which reduces I^2R losses. This will lead to increase in transmission efficiency.

- ✓ With decrease in transmission current, size of conductor required reduces which decreases the volume of conductor.
- ✓ The transmission capacity is proportional to square of operating voltages. Thus the transmission capacity of line increases with increase in voltage.
- ✓ With increase in level of transmission voltage, the installation cost of the transmission line per km decreases.
- ✓ It is economical with EHV transmission to interconnect the power systems on a large scale.
- ✓ The no. of circuits and the land requirement for transmission decreases with the use of higher transmission voltages.

ADVANTAGES

- Reduction in the current.
- Reduction in the losses.
- Reduction in volume of conductor material required.
- Decrease in voltage drop & improvement of voltage regulation.
- Increase in Transmission Efficiency.
- Increased power handling capacity.
- The no. of circuits & the land requirement reduces as transmission voltage increases.
- The total line cost per MW per km decreases considerably with the increase in line voltage.

AVERAGE VALUES OF LINE PARAMETERS

In order to be able to estimate how much power a single-circuit at a given voltage can handle, we need to know the value of positive-sequence line inductance and its reactance at power frequency. Furthermore, in modern practice, line losses caused by I^2R heating of the conductors is gaining in importance because of the need to conserve energy. Therefore, the use of higher voltages than may be dictated by purely economic consideration might be found in order not only to lower the current I to be transmitted but also the conductor resistance R by using bundled conductors comprising of several sub-conductors in parallel. We will utilize average values of parameters for lines with horizontal configuration as shown in Table 1.1 for preliminary estimates. When line resistance is neglected, the power that can be transmitted depends upon (a) the magnitudes of voltages at the ends (E_s , E_r), (b) their phase difference, and (c) the total positive sequence reactance X per phase, when the shunt capacitive admittance is neglected.

Thus,

$$P = \frac{E_s E_r \sin \delta}{LX} \dots(1.1)$$

where P = power in MW, 3-phase, E_s , E_r = voltages at the sending-end and receiving end, respectively, in kV line-line, δ = phase difference between E_s and E_r , x = positive-sequence reactance per phase, ohm/km, and L = line length, km.

Table 1.1: Average Values of Line Parameters

<i>System kV</i>	400	750	1000	1200
<i>Average Height, m</i>	15	18	21	21
<i>Phase Spacing, m</i>	12	15	18	21
<i>Conductor</i>	2 × 32 mm	4 × 30 mm	6 × 46 mm	8 × 46 mm
<i>Bundle Spacing, m</i>	0.4572	0.4572	–	–
<i>Bundle Dia., m</i>	–	–	1.2	1.2
<i>r, ohm/km*</i>	0.031	0.0136	0.0036	0.0027
<i>x, ohm/km (50 Hz)</i>	0.327	0.272	0.231	0.231
<i>x/r</i>	10.55	20	64.2	85.6

*At 20°C. Increase by 12.5% for 50°C.

From consideration of stability, δ is limited to about 30°, and for a preliminary estimate of P , we will take $E_s = E_r = E$.

POWER-HANDLING CAPACITY AND LINE LOSS

According to the above criteria, the power-handling capacity of a single circuit is $P = E^2 \sin \delta / Lx$. At unity power factor, at the load P , the current flowing is

$$I = E \sin \delta / 3 \dots(1.2)$$

and the total power loss in the 3-phases will amount to

$$p = 3I^2 rL = E^2 \cdot \sin^2 \delta \cdot r/Lx^2 \dots(1.3)$$

Therefore, the percentage power loss

$$\%p = 100 p/P = 100 \cdot \sin \delta \cdot (r/x) \dots\dots\dots (1.4)$$

Table 1.2. shows the percentage power loss and power-handling capacity of lines at various voltage levels shown in Table 1.1, for $\delta = 30^\circ$ and without series-capacitor compensation.

Table 1.2 Percent Power Loss and Power-Handling Capacity

<i>System kV</i>	400	750	1000	1200
<i>Percentage, Power Loss</i>	$\frac{50}{10.55} = 4.76$	$\frac{50}{20} = 2.5$	$\frac{50}{64.2} = 0.78$	$\frac{50}{85.6} = 0.584$
<i>Line Length, km</i>				
	$P = 0.5E^2/Lx, MW$			
400	670	2860	6000	8625
600	450	1900	4000	5750
800	335	1430	3000	4310
1000	270	1140	2400	3450
1200	225	950	2000	2875

The following important and useful conclusions can be drawn for preliminary understanding of trends relating to power-handling capacity of a.c. transmission lines and line losses.

- (1) One 750-kV line can normally carry as much power as four 400-kV circuits for equal distance of transmission.
- (2) One 1200-kV circuit can carry the power of three 750-kV circuits and twelve 400-kV circuits for the same transmission distance.
- (3) Similar such relations can be found from the table.
- (4) The power-handling capacity of line at a given voltage level decreases with line length, being inversely proportional to line length L . From equation (1.2) the same holds for current to be carried.
- (5) From the above property, we observe that if the conductor size is based on current rating, as line length increases, smaller sizes of conductor will be necessary. This will increase the danger of high voltage effects caused by smaller diameter of conductor giving rise to corona on the conductors and intensifying radio interference levels and audible noise as well as corona loss.
- (6) However, the *percentage* power loss in transmission remains independent of line length since it depends on the *ratio* of conductor resistance to the positive-sequence reactance per unit length, and the phase difference δ between E_s and E_r .
- (7) From the values of % p given in Table 1.2, it is evident that it decreases as the system voltage is increased. This is very strongly in favour of using higher voltages if energy is to be conserved. With the enormous increase in world oil prices and the need for conserving natural resources, this could sometimes become the governing criterion for selection of voltage for transmission. The Bonneville Power Administration (B.P.A.) in the U.S.A. has based the choice of 1150 kV for transmission over only 280 km length of line since the power is enormous (10,000 MW over one circuit).

(8) In comparison to the % power loss at 400 kV, we observe that if the same power is transmitted at 750 kV, the line loss is reduced to $(2.5/4.76) = 0.525$, at 1000 kV it is $0.78/4.76 = 0.165$, and at 1200 kV it is reduced further to 0.124. Some examples will serve to illustrate the benefits accrued by using very high transmission voltages.

Example 1.1. A power of 12,000 MW is required to be transmitted over a distance of 1000km. At voltage levels of 400 kV, 750 kV, 1000 kV, and 1200 kV, determine:

(1) Possible number of circuits required with equal magnitudes for sending and receiving end

Voltages with 30° phase difference;

(2) The currents transmitted; and

(3) The total line losses.

Assume the values of x given in Table 1.1. Omit series-capacitor compensation.

Solution. This is carried out in tabular form.

System, kv	400	750	1000	1200
x , ohm/km	0.327	0.272	0.231	0.231
$P = 0.5 E^2/Lx$, MW	268	1150	2400	3450
(a) No. of circuits (=12000/P)	45	10–11	5	3–4
(b) Current, kA	17.31	9.232	6.924	5.77
(c) % power loss, p	4.76	2.5	0.78	0.584
Total power loss, MW	571	300	93.6	70

The above situation might occur when the power potential of the Brahmaputra River in North-East India will be harnessed and the power transmitted to West Bengal and Bihar. Note that the total power loss incurred by using 1200 kV ac transmission is almost one-eighth that for 400 kV. The width of land required is far less while using higher voltages, as will be detailed later on.

MECHANICAL CONSIDERATIONS IN LINE PERFORMANCE

Types of Vibrations and Oscillations

In this section a brief description will be given of the enormous importance which designers place on the problems created by vibrations and oscillations of the very heavy conductor arrangement required for e.h.v. transmission lines. As the number of sub-conductors used in a bundle increases, these vibrations and countermeasures

and spacings of sub-conductors will also affect the electrical design, particularly the surface voltage gradient. The mechanical designer will recommend the tower dimensions, phase spacings, conductor height, sub-conductor spacings, etc. from which the electrical designer has to commence his calculations of resistance, inductance, capacitance, electrostatic field, corona effects, and all other performance characteristics. Thus, the two go hand in hand. The sub-conductors in a bundle are separated by spacers of suitable type, which bring their own problems such as fatigue to themselves and to the outer strands of the conductor during vibrations. The design of spacers will not be described here but manufacturers' catalogues should be consulted for a variety of spacers available. These spacers are provided at intervals ranging from 60 to 75 metres between each span which is in the neighbourhood of 300 metres for e.h.v. lines. Thus, there may be two end spans and two or three sub spans in the middle. The spacers prevent conductors from rubbing or colliding with each other in wind and ice storms, if any. However, under less severe wind conditions the bundle spacer can damage itself or cause damage to the conductor under certain critical vibration conditions. Electrically speaking, since the charges on the sub-conductors are of the same polarity, there exists electrostatic repulsion among them. On the other hand, since they carry currents in the same direction, there is electromagnetic attraction. This force is especially severe during short-circuit currents so that the spacer has a force exerted on it during normal or abnormal electrical operation.

Three types of vibration are recognized as being important for e.h.v. conductors, their degree of severity depending on many factors, chief among which are: (a) conductor tension, (b) span length, (c) conductor size, (d) type of conductor, (e) terrain of line, (f) direction of prevailing winds, (g) type of supporting clamp of conductor-insulator assemblies from the tower, (h) tower type, (i) height of tower, (j) type of spacers and dampers, and (k) the vegetation in the vicinity of line. In general, the most severe vibration conditions are created by winds without turbulence so that hills, buildings, and trees help in reducing the severity. The types of vibration are: (1) Aeolian Vibration, (2) Galloping, and (3) Wake-Induced Oscillations. The first two are present for both single- and multi-conductor bundles, while the wake-induced oscillation is confined to a bundle only. Standard forms of bundle conductors have sub-conductors ranging from 2.54 to 5 cm diameters with bundle spacing of 40 to 50 cm between adjacent conductors. For e.h.v. transmission, the number ranges from 2 to 8 sub-conductors for transmission voltages from 400 kV to 1200 kV, and up to 12 or even 18 for higher voltages which are not yet commercially in operation. We will briefly describe the mechanism causing these types of vibrations and the problems created by them.

Aeolian Vibration

When a conductor is under tension and a comparatively steady wind blows across it, small vortices are formed on the leeward side called Karman Vortices (which were first observed on aircraft wings). These vortices detach themselves and when they do alternately from the top and bottom they cause a minute vertical force on the conductor. The frequency of the forces is given by the accepted formula

$$F = 2.065 v/d, \text{ Hz ...}(1.5)$$

where v = component of wind velocity normal to the conductor in km/ hour, and d = diameter of conductor in centimetres. [The constant factor of equation (1.5) becomes 3.26 when v is in mph and d in inches.]

The resulting oscillation or vibrational forces cause fatigue of conductor and supporting structure and are known as aeolian vibrations. The frequency of detachment of the Karman vortices might correspond to one of the natural mechanical frequencies of the span, which if not damped properly, can build up and destroy individual strands of the conductor at points of restraint such as at supports or at bundle spacers. They also give rise to wave effects in which the vibration travels along the conductor suffering reflection at discontinuities at points of different mechanical characteristics. Thus, there is associated with them a mechanical impedance. Dampers are designed on this property and provide suitable points of negative reflection to reduce the wave amplitudes. Aeolian vibrations are not observed at wind velocities in excess of 25 km/hour. They occur principally in terrains which do not disturb the wind so that turbulence helps to reduce aeolian vibrations. In a bundle of 2 conductors, the amplitude of vibration is less than for a single conductor due to some cancellation effect through the bundle spacer. This occurs when the conductors are not located in a vertical plane which is normally the case in practice. The conductors are located in nearly a horizontal plane. But with more than 2 conductors in a bundle, conductors are located in both planes. Dampers such as the Stockbridge type or other types help to damp the vibrations in the subspans connected to them, namely the end sub-spans, but there are usually two or three sub-spans in the middle of the span which are not protected by these dampers provided only at the towers. Flexible spacers are generally provided which may or may not be designed to offer damping. In cases where they are purposely designed to damp the sub-span oscillations, they are known as spacer-dampers. Since the aeolian vibration depends upon the power imparted by the wind to the conductor, measurements under controlled conditions in the laboratory are carried out in wind tunnels. The frequency of vibration is usually limited to 20 Hz and the amplitudes less than 2.5 cm.

Galloping

Galloping of a conductor is a very high amplitude, low-frequency type of conductor motion and occurs mainly in areas of relatively flat terrain under freezing rain and icing of conductors. The flat terrain provides winds that are uniform and of a low turbulence. When a conductor is iced, it presents an unsymmetrical cross-section with the windward side having less ice accumulation than the leeward side of the conductor. When the wind blows across such a surface, there is an aerodynamic lift as well as a drag force due to the direct pressure of the wind. The two forces give rise to torsional modes of oscillation and they combine to oscillate the conductor with very

large amplitudes sufficient to cause contact of two adjacent phases, which may be 10 to 15 metres apart in the rest position. Galloping is induced by winds ranging from 15 to 50 km/hour, which may normally be higher than that required for aeolian vibrations but there could be an overlap. The conductor oscillates at frequencies between 0.1 and 1 Hz. Galloping is controlled by using "detuning pendulums" which take the form of weights applied at different locations on the span. Galloping may not be a problem in a hot country like India where temperatures are normally above freezing in winter. But in hilly tracts in the North, the temperatures may dip to below the freezing point. When the ice loosens from the conductor, it brings another oscillatory motion called Whipping but is not present like galloping during only winds.

Wake-Induced Oscillation

The wake-induced oscillation is peculiar to a bundle conductor, and similar to aeolian vibration and galloping occurring principally in flat terrain with winds of steady velocity and low turbulence. The frequency of the oscillation does not exceed 3 Hz but may be of sufficient amplitude to cause clashing of adjacent sub-conductors, which are separated by about 50 cm. Wind speeds for causing wake-induced oscillation must be normally in the range 25 to 65 km/hour. As compared to this, aeolian vibration occurs at wind speeds less than 25 km/hour, has frequencies less than 20 Hz and amplitudes less than 2.5 cm. Galloping occurs at wind speeds between 15 and 50 km/hour, has a low frequency of less than 1 Hz, but amplitudes exceeding 10 metres. Fatigue failure to spacers is one of the chief causes for damage to insulators and conductors. Wake-induced oscillation, also called "flutter instability", is caused when one conductor on the windward side aerodynamically shields the leeward conductor. To cause this type of oscillation, the leeward conductor must be positioned at rest towards the limits of the wake or windshadow of the windward conductor. The oscillation occurs when the bundle

tilts 5 to 15° with respect to a flat ground surface. Therefore, a gently sloping ground with this angle can create conditions favourable to wake-induced oscillations. The conductor spacing to diameter ratio in the bundle is also critical. If the spacing B is less than $15d$, d being the conductor diameter, a tendency to oscillate is created while for $B/d > 15$ the bundle is found to be more stable. As mentioned earlier, the electrical design, such as calculating the surface voltage gradient on the conductors, will depend upon these mechanical considerations.

Dampers and Spacers

When the wind energy imparted to the conductor achieves a balance with the energy dissipated by the vibrating conductor, steady amplitudes for the oscillations occur. A damping device helps to achieve this balance at smaller amplitudes of aeolian vibrations than an undamped conductor.

A simpler form of damper is called the Armour Rod, which is a set of wires twisted around the line conductor at the insulator supporting conductor and hardware, and extending for about 5 metres on either side. This is used for small conductors to provide a change in mechanical impedance. But for heavier conductors, weights must be used, such as the Stockbridge, which range from 5 kg for conductors of 2.5 cm diameter to 14 kg for 4.5 cm. Because of the steel strands inside them ACSR conductors have better built-in property against oscillations than ACAR conductors.

Resistance Of Conductors

Conductors used for e.h.v. transmission lines are always stranded. Most common conductors use a steel core for reinforcement of the strength of aluminium, but recently high tensile strength aluminium is being increasingly used, replacing the steel. The former is known as ACSR (Aluminium Conductor Steel Reinforced) and the latter ACAR (Aluminium Conductor Alloy Reinforced). A recent development is the AAAC (All Aluminium Alloy Conductor) which consists of alloys of Al, Mg, Si. This has 10 to 15% less loss than ACSR. When a steel core is used, because of its high permeability and inductance, power-frequency current flows only in the aluminium strands. In ACAR and AAAC conductors, the cross-section is better utilized. Fig. 1.1 shows an example of a stranded conductor.

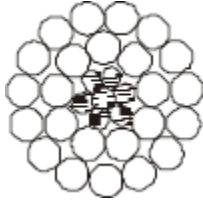

Fig 1.1 Cross-section of typical ACSR conductor.

If n_s = number of strands of aluminium, d_s = diameter of each strand in metre and ρ_a = specific resistance of Al, ohm-m, at temperature t , the resistance of the stranded conductor per km is

$$R = \rho_a \frac{1.05 \times 10^3}{2 \sqrt{4\pi d_s^2 n_s}} = 1337 \rho_a \frac{1.05}{\sqrt{4\pi d_s^2 n_s}}, \text{ ohms} \quad \dots(1.6)$$

The factor 1.05 accounts for the twist or lay whereby the strand length is increased by 5%.

PROPERTIES OF BUNDLED CONDUCTORS

Bundled conductors are exclusively used for e.h.v. transmission lines. Only one line in the world, that of the Bonneville Power Administration in the U.S.A., has used a special expanded ACSR conductor of 2.5 inch diameter for their 525 kV line. Fig. 1.2 shows examples of conductor configurations used for each phase of ac lines or each pole of a dc line.

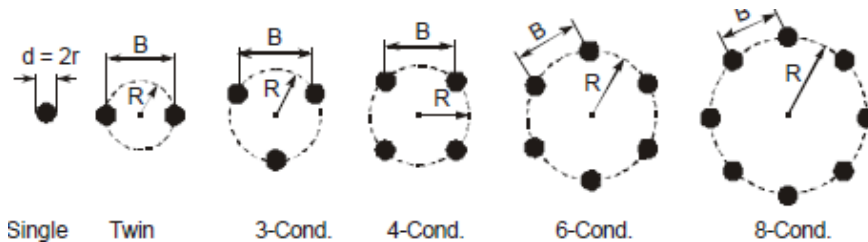

Fig. 1.2 Conductor configurations used for bundles in e.h.v. lines.

As of now a maximum of 18 sub-conductors have been tried on experimental lines but for commercial lines the largest number is 8 for 1150-1200 kV lines.

INDUCTANCE OF E.H.V. LINE CONFIGURATIONS

Fig. 1.3 shows several examples of line configuration used in various parts of the world. They range from single-circuit (S/C) 400 kV lines to proposed 1200 kV lines. Double-circuit (D/C) lines are not very common, but will come into practice

to save land for the line corridor. As pointed out in UNIT 2, one 750 kV circuit can transmit as much power as 4-400 kV circuits and in those countries where technology for 400 kV level exists there is a tendency to favour the four-circuit 400 kV line instead of using the higher voltage level. This will save on import of equipment from other countries and utilize the know-how of one's own country. This is a National Policy and will not be discussed further.

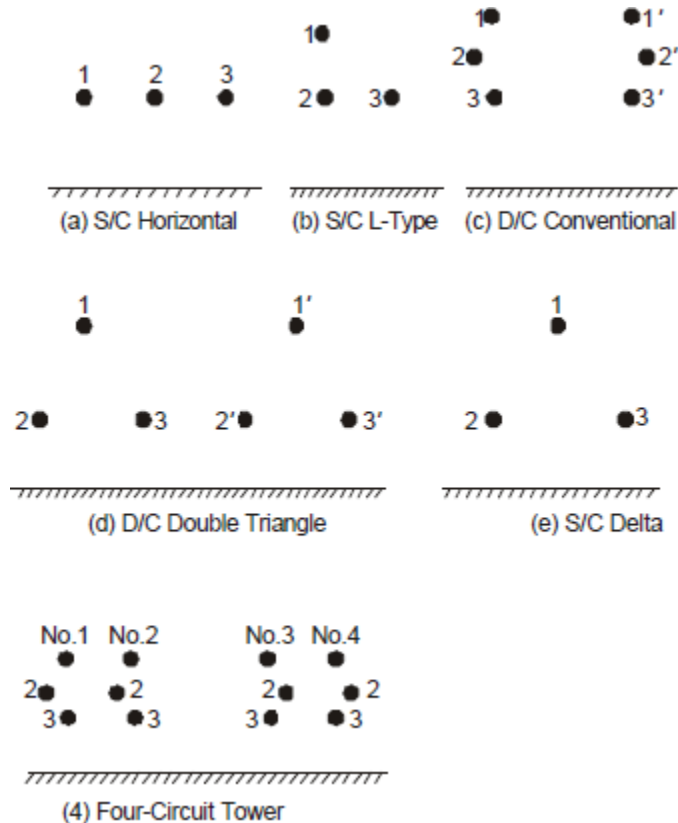

Fig. 1.3 E.h.v. line configurations used.

Inductance of Two Conductors

We shall very quickly consider the method of handling the calculation of inductance of two conductors each of external radius r and separated by a distance D which forms the basis for the calculation of the matrix of inductance of multi-conductor configurations.

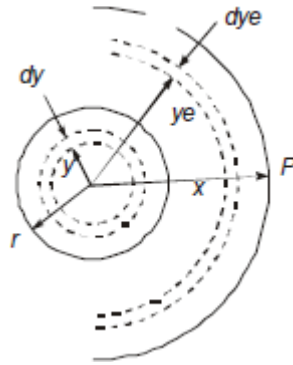

Fig. 1.4 Round conductor with internal and external flux linkages.

Figure 1.4 shows a round conductor carrying a current I . We first investigate the flux linkage experienced by it due, up to a distance x , to its own current, and then extend it to two conductors. The conductor for the present is assumed round and solid, and the current is also assumed to be uniformly distributed with a constant value for current density $J = I/\pi r^2$. There are two components to the flux linkage: (1) flux internal to the conductor up to r ; and (2) flux external to the conductor from r up to x .

Inductance Due to Internal Flux

At a radius y inside the conductor, Ampere's circuital law gives $\oint H \cdot dl =$ current enclosed. With a uniform current density J , the current enclosed up to radius y is $I_y = y^2 I/r^2$. This gives,

$$H_y \cdot 2\pi y = I y^2 / r^2 \text{ or, } H_y = \frac{I}{2\pi r^2} \cdot y$$

Now, the energy stored in a magnetic field per unit volume is

$$w_y = \frac{1}{2} \mu_0 \mu_r H_y^2 = \frac{I^2 \mu_0 \mu_r}{8\pi^2 r^4} y^2, \text{ Joules/m}^3$$

Consider an annular volume at y , thickness dy , and one metre length of conductor. Its volume is $(2\pi y \cdot dy \cdot 1)$ and the energy stored is

$$dW = 2\pi y \cdot w_y \cdot dy = \frac{I^2 \mu_0 \mu_r}{4\pi r^4} y^3 \cdot dy$$

Consequently, the total energy stored up to radius r in the conductor can be calculated. But this is equal to, $\frac{1}{2} Li^2$ where $= Li =$ inductance of the conductor per metre due to the internal flux linkage.

Therefore,

$$\frac{1}{2} L_i I^2 = \int_0^r dW = \frac{I^2 \mu_0 \mu_r}{4\pi r^4} \int_0^r y^3 dy = \frac{\mu_0 \mu_r}{16\pi} I^2$$

Consequently,

$$L_i = \mu_0 \mu_r / 8\pi, \text{ Henry/metre}$$

For a non-magnetic material, $\mu_r = 1$. With $\mu_0 = 4\pi \times 10^{-7}$ H/m, we obtain the interesting result that irrespective of the size of the conductor, the inductance due to internal flux linkage is

$$L_i = 0.05 \mu \text{ Henry/metre for } \mu_r = 1$$

The effect of non-uniform current distribution at high frequencies is handled in a manner similar to the resistance. Due to skin effect, the internal flux linkage decreases with frequency, contrary to the behaviour of resistance. The equation for the inductive reactance is (W.D. Stevenson, 2nd Ed.)

$$X_i(f) = R_0 \cdot (X/2) \cdot \frac{\text{Ber}(X) \cdot \text{B'er}(X) + \text{Bei}(X) \cdot \text{B'ei}(X)}{[\text{B'er}(X)]^2 + [\text{B'ei}(X)]^2}$$

where $X_i(f)$ = reactance due to internal flux linkage at any frequency f , R_0 = dc resistance of conductor per mile in ohms, and $X = 0.0636 f/R_0$. [If R_m = resistance per metre, then $X = 1.59 \times 10^{-3} f/R_m$.]

SEQUENCE INDUCTANCES AND CAPACITANCES

The use of Symmetrical Components for analysing 3-phase problems has made it possible to solve very extensive network problems. It depends upon obtaining mutually-independent quantities from the original phase quantities that have mutual interaction. Following this concept, we will now resolve the inductances, capacitances, charges, potentials etc., into independent quantities by a general method. This procedure will be used for many types of excitations other than power-frequency later on. The basis for such transformations is to impress suitable driving functions and obtain the resulting responses.

RESISTANCE AND INDUCTANCE OF GROUND RETURN

Under balanced operating conditions of a transmission line, ground-return currents do not flow. However, many situations occur in practice when ground currents have important effect on system performance. Some of these are:

- (a) Flow of current during short circuits involving ground. These are confined to single line to ground and double line to ground faults. During three phase to ground faults the system is still balanced;
- (b) Switching operations and lightning phenomena;

- (c) Propagation of waves on conductors;
- (d) Radio Noise studies.

The ground-return resistance increases with frequency of the current while the inductance decreases with frequency paralleling that of the resistance and inductance of a conductor. In all cases involving ground, the soil is inhomogeneous and stratified in several layers with different values of electrical conductivity. In this section, the famous formulas of J.R. Carson (B.S.T.J. 1926) will be given for calculation of ground resistance and inductance at any frequency in a homogeneous single-layer soil. The problem was first applied to telephone transmission but we will restrict its use to apply to e.h.v. transmission lines.

UNIT-2

Voltage Gradients of Conductors

ELECTROSTATICS

Conductors used for E.H.V transmission lines are thin long cylinders which are known as 'line charges'. The problems created by charges on the conductors manifest themselves as high electrostatic field in the line vicinity from power frequency to TV frequencies through audio frequency, carrier frequency and radio frequency (*PF, AF, CF, TVF*). The attenuation of travelling waves is also governed in some measure by the increase in capacitance due to corona discharges which surround the space near the conductor with charges. When the macroscopic properties of the electric field are studied, the conductor charge is assumed to be concentrated at its centre, even though the charge is distributed on the surface. In certain problems where proximity of several conductors affects the field distribution, or where conducting surfaces have to be forced to become equipotential surfaces (in two dimensions) in the field of several charges it is important to replace the given set of charges on the conductors with an infinite set of charges. This method is known as the Method of Successive Images. In addition to the electric-field properties of long cylinders, there are other types of important electrode configurations useful for extra high voltage practice in the field and in laboratories. Examples of this type are sphere-plane gaps, sphere-to-sphere gaps, point-to-plane gaps, rod-to-plane gaps, rod-rod gaps, conductor-to-tower gaps, conductor to- conductor gap above a ground plane, etc. Some of these types of gaps will also be dealt with in this UNIT which may be used for e.h.v. measurement, protection, and other functions. The coaxial-cylindrical electrode will also be discussed in great detail because of its importance in corona studies where the bundle of N sub-conductors is strung inside a 'cage' to simulate the surface voltage gradient on the conductors in a setup which is smaller in dimensions than an actual outdoor transmission line.

FIELD OF SPHERE GAP

A sphere-sphere gap is used in h.v. laboratories for measurement of extra high voltages and for calibrating other measuring apparatus. If the gap spacing is less than the sphere radius, the field is quite well determined and the sphere-gap breaks down consistently at the same voltage with a dispersion not exceeding $\pm 3\%$. This

is the accuracy of such a measuring gap, if other precautions are taken suitably such as no collection of dust or proximity of other grounded objects close by. The sphere-gap problem also illustrates the method of successive images used in electrostatics.

Figure 2.1 shows two spheres of radii R separated by a centre-to-centre distance of S , with one sphere at zero potential (usually grounded) and the other held at a potential V . Since both spheres are metallic, their surfaces are equi potentials. In order to achieve this, it requires a set of infinite number of charges, positive inside the left sphere at potential V and negative inside the right which is held at zero potential. The magnitude and position of these charges will be determined from which the voltage gradient resulting on the surfaces of the sphere on a line joining the centres can be determined. If this exceeds the critical disruptive voltage, a spark break-down will occur. The voltage required is the breakdown voltage.

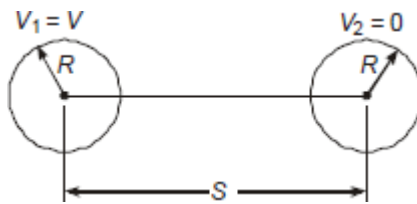

Fig. 2.1 The sphere gap.

Consider two point charges Q_1 and Q_2 located with a separation D , Figure 2.2. At a point $P(x, y)$ with coordinates measured from Q_1 , the potentials are as follows:

Potential at P due to Q_1

$$= \frac{Q_1}{4\pi\epsilon_0} \frac{1}{r_1} \text{ with } r_1 = \sqrt{x^2 + y^2}$$

Potential at P due to Q_2

$$= \frac{Q_2}{4\pi\epsilon_0} \frac{1}{r_2} \text{ with } r_2 = \sqrt{(D-x)^2 + y^2}$$

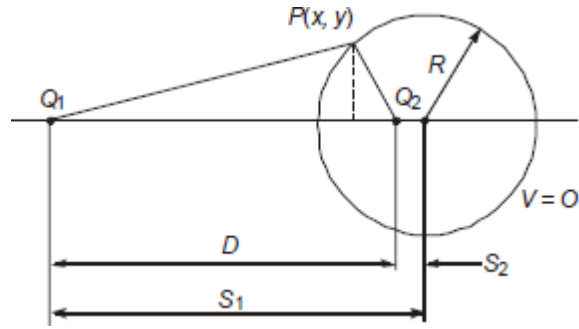

Fig. 2.2 Point charge Q_1 and sphere of radius R .

The total potential at P is

$$V_P = \frac{1}{4\pi\epsilon_0} (Q_1/r_1 + Q_2/r_2).$$

If this is to be zero, then $Q_2/Q_1 = -r_2/r_1$... (2. 1)

This clearly shows that Q_1 and Q_2 must be of opposite polarity.

FIELD OF LINE CHARGES AND THEIR PROPERTIES

Figure 2.3 shows a line charge of q coulomb/metre and we will calculate the electric field strength, potential, etc., in the vicinity of the conductor. First, enclose the line charge by a Gaussian cylinder, a cylinder of radius r and length 1 metre. On the flat surfaces the field will not have an outward normal component since for an element of charge dq located at S , there can be found a corresponding charge located at S' whose fields (force exerted on a positive test charge) on the flat surface F will yield only a radial component. The components parallel to the line charge will cancel each other out. Then, by Gauss's Law, if $E_p =$ field strength normal to the curved surface at distance r from the conductor,

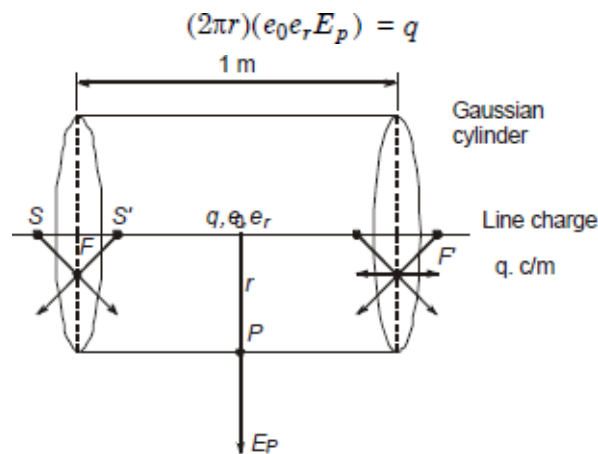

Fig. 2.3 Line charge with Gaussian cylinder.

The field strength at a distance r from the conductor is

$$E_p = (q/2\pi\epsilon_0\epsilon_r)(1/r), \text{ Volts/metre}$$

This is called the $(1/r)$ -field as compared to the $(1/r^2)$ -field of a point charge.

Let a reference distance r_0 be chosen in the field. Then the potential difference between any point at distance r and the reference is the work done on a unit test charge from r_0 to r .

Thus,

$$V_r = \frac{q}{2\pi\epsilon_0\epsilon_r} \int_{r_0}^r \frac{1}{\rho} d\rho = \frac{q}{2\pi\epsilon_0\epsilon_r} (\ln r_0 - \ln r)$$

In the case of a line charge, the potential of a point in the field with respect to infinity cannot be defined as was done for a point charge because of logarithmic term. However, we can find the p.d. between two points at distances r_1 and r_2 , since

(p.d. between r_1 and r_2) = (p.d. between r_1 and r_0) – (p.d. between r_2 and r_0)

i.e.

$$V_{12} = \frac{q}{2\pi\epsilon_0\epsilon_r} (\ln r_2 - \ln r_1) = \frac{q}{2\pi\epsilon_0\epsilon_r} \ln \frac{r_2}{r_1}$$

In the field of a positive line charge, points nearer the charge will be at a higher positive potential than points farther away ($r_2 > r_1$).

The potential (p.d. between two points, one of them being taken as reference r_0) in the field of a line charge is logarithmic. Equipotential lines are circles. In a practical situation, the charge distribution of a transmission line is closed, there being as much positive charge as negative.

SURFACE VOLTAGE GRADIENT ON CONDUCTORS

The surface voltage gradient on conductors in a bundle governs generation of corona on the line which have serious consequences causing audible noise and radio interference. They also affect carrier communication and signalling on the line and cause interference to television reception. The designer of a line must eliminate these nuisances or reduce them to tolerable limits specified by standards, if any exist. These limits will be discussed at appropriate places where AN, RI and other interfering fields are discussed in the next two UNITS. Since corona generation depends on the voltage gradient on conductor surfaces, this will be taken up now for e.h.v. conductors with number of sub-conductors in a bundle ranging from 1 to N . The maximum value of N is 8 at present but a general derivation is not difficult.

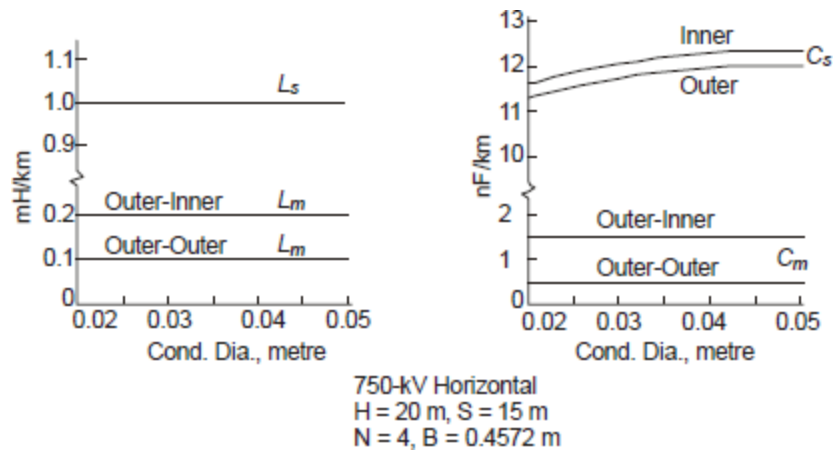

Fig. 2.4. L and C of 750 kV horizontal line.

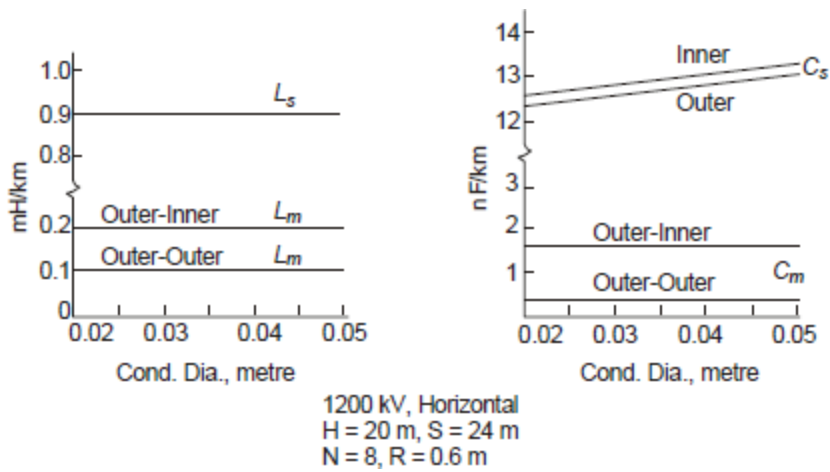

Fig. 2.5 L and C of 1200 kV horizontal line.

UNIT-3

Corona Effects

Power Loss and Audible Noise

The average power-handling capacity of a 3-phase e.h.v. line and percentage loss due to I^2R heating were discussed. Representative values are given below for comparison purposes.

System kV	400		750		1000		1150	
Line Length, km	400	800	400	800	400	800	400	800
3-Phase MW/circuit ($P = 0.5 V^2/xL$)	640	320	2860	1430	6000	3000	8640	4320
% Power Loss = $50 r/x$	4.98%		2.4%		0.8%		0.6%	
kW/km Loss, 3-phase	80	20	170	42.5	120	30	130	32.5

When compared to the I^2R heating loss, the average corona losses on several lines from 345 kV to 750 kV gave 1 to 20 kW/km in fair weather, the higher values referring to higher voltages. In foul-weather, the losses can go up to 300 kW/km. Since, however, rain does not fall all through the year (an average is 3 months of precipitation in any given locality) and precipitation does not cover the entire line length, the corona loss in kW/km cannot be compared to I^2R loss directly. A reasonable estimate is the yearly average loss which amounts to roughly 2 kW/km to 10 kW/km for 400 km lines, and 20-40 kW/km for 800 km range since usually higher voltages are necessary for the longer lines. Therefore, cumulative annual average corona loss amounts only to 10% of I^2R loss, on the assumption of continuous full load carried. With load factors of 60 to 70%, the corona loss will be a slightly higher percentage. Nonetheless, during rainy months, the generating station has to supply the heavy corona loss and in some cases it has been the experience that generating stations have been unable to supply full rated load to the transmission line. Thus, corona loss is a very serious aspect to be considered in line design.

When a line is energized and no corona is present, the current is a pure sine wave and capacitive. It leads the voltage by 90° , as shown in Figure 3.1(a). However, when corona is present, it calls for a loss component and a typical waveform of the total current is as shown in Figure 3.1 (b). When the two components are separated, the resulting inphase component has a waveform which is not purely

sinusoidal, Figure 3.1 (c). It is still a current at power frequency, but only the fundamental component of this distorted current can result in power loss.

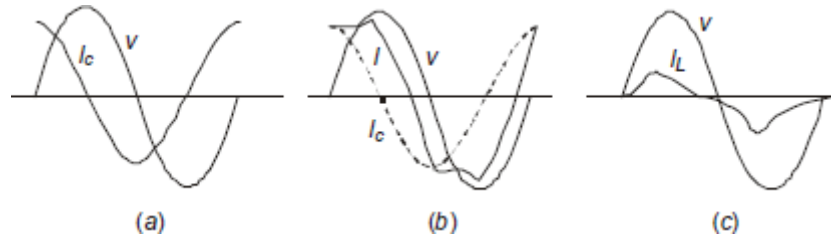

Fig. 3.1 Corona current waveform.

CORONA-LOSS FORMULAE

List of Formulae

Corona-loss formulae were initiated by F.W. Peek Jr. in 1911 derived empirically from most difficult and painstaking experimental work. Since then a horde of formulae have been derived by others, both from experiments and theoretical analysis. They all yield the power loss as a function of (a) the corona-inception voltage, V_0 ; (b) the actual voltage of conductor, V ; (c) the excess voltage ($V - V_0$) above V_0 ; (d) conductor surface voltage gradient, E ; (e) corona-inception gradient, E_0 ; (f) frequency, f ; (g) conductor size, d , and number of conductors in bundle, N , as well as line configuration; (h) atmospheric condition, chiefly rate of rainfall, r , and (i) conductor surface condition.

A. Those Based on Voltages

(i) *Linear relationship* : Skilling's formula (1931):

$$P_c \propto V - V_0$$

(ii) *Quadratic relationship*

(a) Peek's formula (1911):

$$P_c \propto (V - V_0)^2$$

(b) Ryan and Henline formula (1924):

$$P_c \propto V(V - V_0)$$

(c) Peterson's formula (1933) :

$$P_c \propto V^2 \cdot F(V/V_0)$$

where F is an experimental factor.

(iii) *Cubic Relationship*

(a) Foust and Menger formula (1928):

$$Pc \propto V^3$$

(b) Prinz's formula (1940):

$$Pc \propto V^2 (V - V_0)$$

B. Those Based on Voltage Gradients

(a) Nigol and Cassan formula (1961):

$$Pc \propto E^2 \ln (E/E_0)$$

(b) Project EHV formula (1966):

$$Pc \propto V \cdot E_m, m = 5$$

In order to obtain corona-loss figures from e.h.v. conductor configurations, outdoor experimental projects are established in countries where such lines will be strung. The resulting measured values pertain to individual cases which depend on local climatic conditions existing at the projects. It is therefore difficult to make a general statement concerning which formula or loss figures fit coronal losses universally.

CHARGE-VOLTAGE ($q - V$) DIAGRAM AND CORONA LOSS

Increase in Effective Radius of Conductor and Coupling Factors

The partial discharge of air around a line conductor is the process of creation and movement of charged particles and ions in the vicinity of a conductor under the applied voltage and field. We shall consider a simplified picture for conditions occurring when first the voltage is passing through the negative half-cycle and next the positive half-cycle, as shown in Figure 3.2.

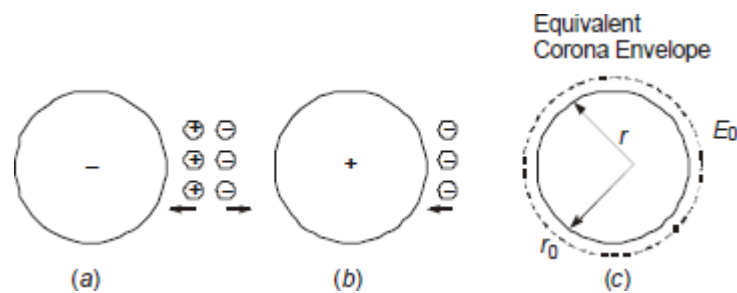

Fig. 3.2 Space-charge distribution in corona and increase in effective radius of conductor

In Figure 3.2(a), free electrons near the negative conductor when repelled can acquire sufficient energy to form an electron avalanche. The positive ions (a neutral molecule which has lost an electron) are attracted towards the negative conductor while the electrons drift into lower fields to attach themselves to neutral atoms or molecules of Nitrogen and Oxygen to form negative ions. Some recombination could also take place. The energy imparted for causing initial ionization by collision is supplied by the electric field. During the positive half cycle, the negative ions are attracted towards the conductor, but because of local conditions not all ions drift back to the conductor. A space charge is left behind and the hysteresis effect gives rise to the energy loss. Furthermore, because of the presence of charged particles, the effective charge of the conductor ground electrode system is increased giving rise to an increase in effective capacitance. This can be interpreted in an alternative manner by assuming that the conductor diameter is effectively increased by the conducting channel up to a certain extent where the electric field intensity decreases to a value equal to that required for further ionization, namely, the corona-inception gradient, Figure 3.2(c).

AUDIBLE NOISE: GENERATION AND CHARACTERISTICS

When corona is present on the conductors, e.h.v. lines generate audible noise which is especially high during foul weather. The noise is broadband, which extends from very low frequency to about 20 kHz. Corona discharges generate positive and negative ions which are alternately attracted and repelled by the periodic reversal of polarity of the ac excitation. Their movement gives rise to sound-pressure waves at frequencies of twice the power frequency and its multiples, in addition to the broadband spectrum which is the result of random motions of the ions, as shown in Figure 3.3. The noise has a pure tone superimposed on the broadband noise. Due to differences in ionic motion between ac and dc excitations, dc lines exhibit only a broad bandnoise, and furthermore, unlike for ac lines, the noise generated from a dc line is nearly equal in both fair and foul weather conditions. Since audible noise (AN) is man-made, it is measured in the same manner as other types of man-made noise such as aircraft noise, automobile ignition noise, transformer hum, etc.

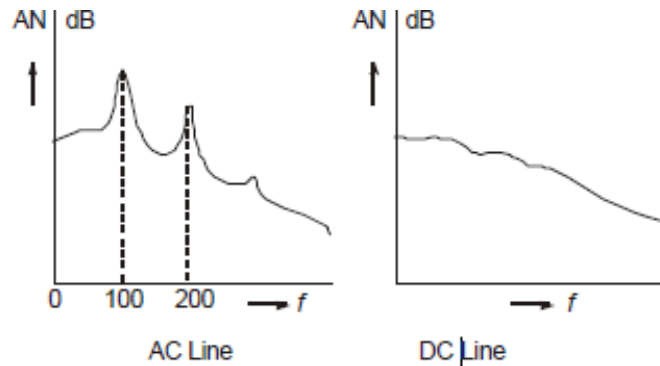

Fig. 3.3 Audible Noise frequency spectra from ac and dc transmission lines.

Audible noise can become a serious problem from 'psycho-acoustics' point of view, leading to insanity due to loss of sleep at night to inhabitants residing close to an e.h.v. line. This problem came into focus in the 1960's with the energization of 500 kV lines in the USA. Regulatory bodies have not as yet fixed limits to AN from power transmission lines since such regulations do not exist for other man-made sources of noise. The problem is left as a social one which has to be settled by public opinion.

LIMITS FOR AUDIBLE NOISE

Since no legislation exists setting limits for AN for man-made sources, power companies and environmentalists have fixed limits from public-relations point of view which power companies have accepted from a moral point of view. In doing so, like other kinds of interference, human beings must be subjected to listening tests. Such objective tests are performed by every civic minded power utility organization. The first such series of tests performed from a 500-kV line of the Bonneville Power Administration in the U.S.A. is known as Perry Criterion. The AN limits are as follows:

No complaints : Less than 52.5 dB (A),

Few complaints : 52.5 dB (A) to 59 dB (A),

Many complaints : Greater than 59 dB (A),

The reference level for audible noise and the dB relation will be explained later.

The notation (A) denotes that the noise is measured on a meter on a filter designated as A-weighting network. There are several such networks in a meter.

Design of line dimensions at e.h.v. levels is now governed more by the need to limit AN levels to the above values. The selection of width of line corridor or right-of-way (R-O-W), where the nearest house can be permitted to be located, is fixed from AN limit of 52.5 dB(A),

will be found adequate from other points of view at 1000 to 1200 kV levels. The audible noise generated by a line is a function of the following factors:

- (a) the surface voltage gradient on conductors,
- (b) the number of sub-conductors in the bundle,
- (c) conductor diameter,
- (d) atmospheric conditions, and
- (e) the lateral distance (or aerial distance) from the line conductors to the point where noise is to be evaluated.

The entire phenomenon is statistical in nature, as in all problems related to e.h.v. line designs, because of atmospheric conditions. with atmospheric conditions but also with the hours of the day and night during a 24-hour period. The reason is that a certain noise level which can be tolerated during the waking hours of the day, when ambient noise is high, cannot be tolerated during sleeping hours of the night when little or no ambient noises are present.

CORONA PULSES: THEIR GENERATION AND PROPERTIES

There are in general two types of corona discharge from transmission-line conductors: (i) Pulse less or Glow Corona; (ii) Pulse Type or Streamer Corona. Both these give rise to energy loss, but only the pulse-type of corona gives interference to radio broadcast in the range of 0.5 MHz to 1.6 MHz. In addition to corona generated on line conductors, there are spark discharges from chipped or broken insulators and loose guy wires which interfere with TV reception in the 80–200 MHz range.

Corona on conductors also causes interference to Carrier Communication and Signalling in the frequency range 30 kHz to 500 kHz. In the case of Radio and TV interference the problem is one of locating the receivers far enough from the line in a lateral direction such that noise generated by the line is low enough at the receiver location in order to yield a satisfactory quality of reception. In the case of carrier interference, the problem is one of determining the transmitter and receiver powers to combat line-generated noise power. In the case of Radio and TV interference the problem is one of locating the receivers far enough from the line in a lateral direction such that noise generated by the line is low enough at the receiver location in order to yield a satisfactory quality of reception. In the case of carrier interference, the problem is one of determining the transmitter and receiver powers to combat line-generated noise power.

As in most gas discharge phenomena under high impressed electric fields, free electrons and charged particles (ions) are created in space which contains very few initial electrons. We can therefore expect a buildup of resulting current in the

conductor from a zero value to a maximum or peak caused by the avalanche mechanism and their motion towards the proper electrode. Once the peak value is reached there is a fall in current because of lowering of electric field due to the relatively heavy immobile space charge cloud which lowers the velocity of ions. We can therefore expect pulses to be generated with short crest times and relatively longer fall times. Measurements made of single pulses by the author in co-axial cylindrical arrangement are shown in Figure 3.4 under dc excitation. Similar pulses occur during the positive and negative half-cycles under ac excitation. The best equations that fit the observed wave shapes are also given on the figures. It will be assumed that positive corona pulses have the equation

$$i_+ = k_+ i_p (e^{-\alpha t} - e^{-\beta t})$$

while negative pulses can be best described by

$$i_- = k_- i_p t^{-3/2} \cdot e^{-\gamma/t - \delta t}$$

These equations have formed the basis for calculating the response of bandwidth-limited radio receivers (noise meters), and for formulating mathematical models of the radio-noise problem.

In addition to the wave shape of a single pulse, their repetition rate in a train of pulses is also important.

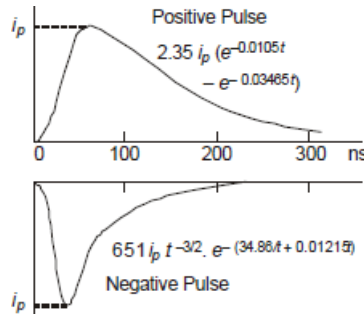

Fig. 3.4 Single positive and negative pulses

$$i_+ = k_+ i_p (e^{-\alpha t} - e^{-\beta t}); i_- = k_- i_p \cdot t^{-1.5} \cdot e^{(-\gamma/t - \delta t)}$$

Referring to Fig. 6.2, when a conductor is positive with respect to ground, an electron avalanche moves rapidly into the conductor leaving the heavy positive-ion charge cloud close to the conductor which drifts away. The rapid movement of electrons and motion of positive-ions gives the steep front of the pulse, while the further drift of the positive-ion cloud will form the tail of the pulse. It is clear that the presence of positive charges near the positive conductor lowers the field to an extent that the induced current in the conductor nearly vanishes. As soon as the positive-ions have drifted far enough due to wind or neutralized by other agencies such as free electrons by recombination, the electric field in the vicinity of the

conductor regains sufficiently high value for pulse formation to repeat itself. Thus, a train of pulses results from a point in corona on the conductor. The repetition rate of pulses is governed by factors local to the conductor. It has been observed that only one pulse usually occurs during a positive half cycle in fair weather and could increase to about 10 in rain where the water sprays resulting from breaking raindrops under the applied field control electrical conditions local to the conductor.

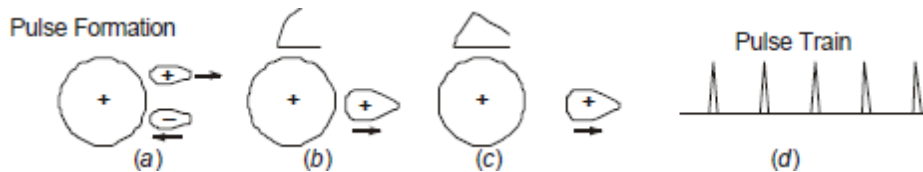

Fig. 3.4 Formation of pulse train from positive polarity conductor.

The situation when the conductor is negative with respect to ground is the reverse of that described above. The electron avalanche moves away from the conductor while the positive-ion cloud moves towards the negatively-charged conductor. However, since the heavy positive-ions are moving into progressively higher electric fields, their motion is very rapid which gives rise to a much sharper pulse than a positive pulse. Similarly, the lighter electrons move rapidly away from the conductor and the electric field near the conductor regains its original value for the next pulse generation quicker than for the positive case. Therefore, negative pulses are smaller in amplitude, have much smaller rise and fall times but much higher repetition rates than positive pulses. It must at once be evident that all the properties of positive and negative pulses are random in nature and can only be described through random variables.

Typical average values of pulse properties are as follows:

Type	Time to Crest	Time to 50% on Tail	Peak Value of Current	Repetition Rate Pulses per Second	
				A.C.	D.C.
Positive	50 ns	200 ns	100 mA	Power Freq.	1,000
Negative	20 ns	50 ns	10 mA	100 × P.F.	10,000

Pulses are larger as the diameter of conductor increases because the reduction in electric field strength as one moves away from the conductor is not as steep as for a smaller conductor so that conditions for longer pulse duration are more favorable. In very small wires, positive pulses can be absent and only a glow corona can result, although negative pulses are present when they are known as Trichel Pulses named after the first discoverer of the pulse-type discharge. Therefore, only positive polarity pulses are important because of their larger amplitudes even though their repetition rate is lower than negative pulses.

FREQUENCY SPECTRUM OF THE RI FIELD OF LINE

The frequency spectrum of radio noise refers to the variation of noise level in μV or $\mu\text{V/m}$ (or their dB values referred to 1 μV or 1 $\mu\text{V/m}$) with frequency of measurement.

$$A(\omega) = K i_p (\beta - \alpha) / \sqrt{(\alpha^2 + \omega^2)(\beta^2 + \omega^2)}$$

On a long line, there exist a very large number of points in corona and a noise meter located in the vicinity of the line (usually at or near ground level) responds to a train of pulses originating from them. The width of a single pulse is about 200 ns (0.2 μs) while the separation of pulses as seen by the input end of the meter could be 1 μs or more. Therefore, it is unusual for positive pulses to overlap and the noise is considered as impulsive. When pulses overlap, the noise is random. Measurements indicate that from a long line, the RI frequency spectrum follows closely.

$$RI(\omega) \propto f^{-1} \text{ to } f^{-1.5}$$

Thus, at 0.5 MHz the noise is 6-9 dB higher than at 1 MHz, while at 2 MHz it is 6–9 dB lower. In practice, these are the adders suggested to convert measured noise at any frequency to 1 MHz level. The frequency spectrum is therefore very important in order to convert noise levels measured at one frequency to another. This happens when powerful station signal interferes with noise measurements from a line so that measurements have to be carried out at a frequency at which no broadcast station is radiating. The frequency spectrum from corona generated line noise is nearly fixed in its characteristic so that any deviation from it as measured on a noise meter is an indication of sources other than the line, which is termed "back ground noise". In case a strong source of noise is present nearby, which is usually a factory with motors that are sparking or a broken insulator on the tower, this can be easily recognized since these usually yield high noise levels up to 30 MHz and their frequency spectrum is relatively flat.

LATERAL PROFILE OF RI AND MODES OF PROPAGATION

The most important aspect of line design from interference point of view is the choice of conductor size, number of sub-conductors in bundle, line height, and phase spacing. Next in importance is the fixing of the width of line corridor for purchase of land for the right-of-way. The lateral decrement of radio noise measured at ground level as one moves away from the line has the profile sketched in Fig. 3.5. It exhibits a characteristic double hump within the space between the conductors and then decreases monotonically as the meter is moved away from the

outer phase. receiver should be located within the distance d_0 from the outer phase or d_c from the line centre. Therefore, it becomes essential to measure or to be able to calculate at design stages the lateral profile very accurately from a proposed line in order to advise regulatory bodies on the location of receivers. In practice, many complaints are heard from the public who experience interference to radio broadcasts if the line is located too close to their homesteads when the power company routes an e.h.v. line wrongly. In such cases, it is the engineer's duty to recommend remedies and at times appear as witness in judicial courts to testify on the facts of a case.

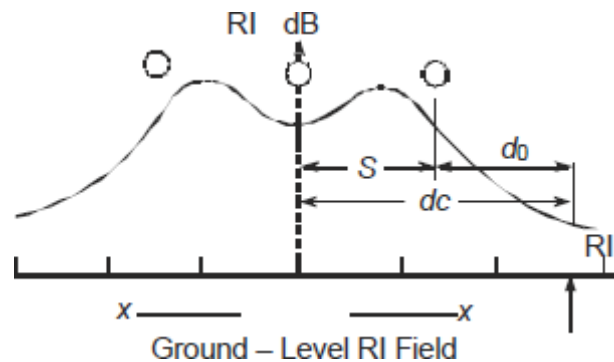

Fig. 3.5 Lateral profile of RI at ground level for fixing width of right-of-way of line

for the radio-frequency energy on the multi-conductor line. This is the basis for determining the expected noise profile from a chosen conductor size and line configuration in un-transposed and fully-transposed condition. We consider 6 preliminary cases of charge distribution on the line conductors after which we will combine these suitably for evaluating the total noise level of a line. In all these cases, the problem is to calculate the field strength at the location of a noise meter when the r - f charge distribution is known. Here, we consider the vertical component of ground-level field intensity which can be related to the horizontal component of magnetic field intensity by the characteristic impedance of free space. We restrict our attention to horizontal 3-phase line for the present. In every case, only the magnitude is of concern.

3.9 THE RI EXCITATION FUNCTION

With the advent of voltages higher than 750 kV, the number of sub conductors used in a bundle has become more than 4 so that the CIGRE formula does not apply. Moreover, very little experience of RI levels of 750 kV lines were available when the CIGRE formula was evolved, as compared to the vast experience with lines for 230 kV, 345 kV, 400 kV and 500 kV. Several attempts were made since

the 1950's to evolve a rational method for predicting the RI level of a line at the design stages before it is actually built when all the important line parameters are varied. These are the conductor diameter, number of sub-conductors, bundle spacing or bundle radius, phase spacing, line height, line configuration (horizontal or delta), and the weather variables. The most important concept resulting from such an attempt in recent years is the "Excitation Function" or the "Generating Function" of corona current injected at a given radio frequency in unit bandwidth into the conductor. This quantity is determined experimentally from measurements carried out with short lengths of conductor strung inside a cylindrical or rectangular cage.

Consider Fig. 3.6 which shows a source of corona at S located at a distance x from one end of a line of length L . According to the method using the Excitation Function to predict the RI level with given dimensions and conductor geometry, the corona source at S on the conductor generates an excitation function I measured in mA/ m. The line has a surge impedance Z_0 so that r-f power generated per unit length of line is

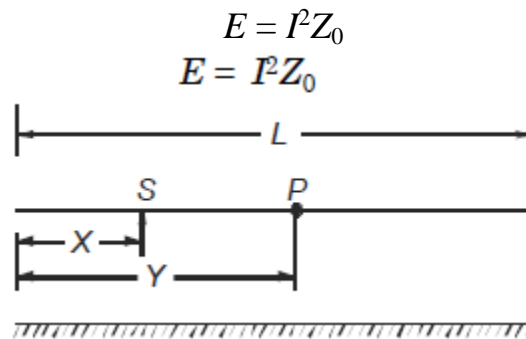

Fig. 3.6 The excitation function and its propagation on line for RI calculation.

Under rain, a uniform energy or power per unit bandwidth is generated so that in a differential length dx , the power generated is $(E.dx)$. In this method, we calculate the RI level under rain first and deduct 17 dB to obtain fair-weather RI. This power will split equally in two directions and travel along the line to reach the point P at a distance $(y-x)$ from the source S . In doing so, it will attenuate to the value $e^{-2a(y-x)}$, where a = attenuation factor for voltage in Nepers per unit length. Therefore, the total energy received at P due to all sources to the left of P will be

$$E_L = \int_0^y \frac{1}{2} (E.dx).e^{-2a(y-x)} = \frac{E}{4a} (1 - e^{-2ay})$$

Similarly, the energy received at P due to all sources to its right will be

$$E_R = \frac{E}{4a}(1 - e^{-2a(L-y)})$$

For a line of finite length, repeated reflections occur from the ends, but for a very long line these are not of consequence. Also, unless the point P is located very close to the ends, the exponential terms can be neglected. Therefore, the total r-f energy received at P will be

$$E_p = E/2a$$

which shows that all points on a long line receive the same r-f energy when the corona generation is uniform.

MEASUREMENT OF RI, RIV, AND EXCITATION FUNCTION

The interference to AM broadcast in the frequency range 0.5 MHz to 1.6 MHz is measured in terms of the three quantities : Radio Interference Field Intensity (RIFI or RI), the Radio Influence Voltage (RIV), and more recently through the Excitation Function. Their units are mV/m, mV, and mA/ m or the decibel values above their reference values of 1 unit (mV /m, mV, mA / m). The nuisance value for radio reception is governed by a quantity or level which is nearly equal to the peak value of the quantity and termed the Quasi Peak. A block diagram of a radio noise meter is shown in Fig. 3.7. The input to the meter is at radio frequency (r-f) which is amplified and fed to a mixer. The rest of the circuit works exactly the same as a highly sensitive super heterodyne radio receiver, However, at the IF output stage, a filter with 5 kHz or 9 kHz bandwidth is present whose output is detected by the diode D . Its output charges a capacitance C through a low resistance R_c such that the charging time constant $T_c = R_c C = 1$ ms. A second resistance R_d is in parallel with C which is arranged to give a time constant $T_d = R_d C = 600$ ms in ANSI meters and 160 ms in CISPR or European standard meters. Field tests have shown that there is not considerable difference in the output when comparing both time constants for line-generated corona noise. The voltage across the capacitor can either be read as a current through the discharge resistor R_d or a micro-voltmeter connected across it.

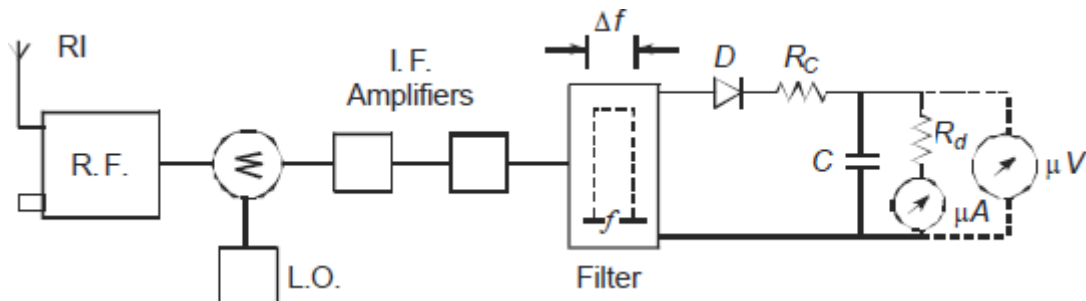

Fig. 3.7 Block diagram of Radio Noise Meter.

MEASUREMENT OF EXCITATION FUNCTION

The corona generating function or the excitation function caused by injected current at radio frequencies from a corona discharge is measured on short lengths of conductor strung inside "cages"

Some examples of measuring radio noise and injected current are shown in Fig.

3.8. In every case the measured quantity is RIV at a fixed frequency and the excitation function calculated. filter provides an attenuation of at least 25 dB so that the RI current is solely due to corona on conductor. The conductor is terminated in a capacitance C_c at one end in series with resistances R_1 and R_c , while the other end is left open. The conductor is strung with strain insulator at both ends which can be considered to offer a very high impedance at 1MHz so that there is an open-termination. But this must be checked experimentally in situ. The coupling capacitor has negligible reactance at r-f so that the termination at the measuring end is nearly equal to $(R_1 + R_c)$, where $R_c =$ surge impedance of the cable to the noise meter. The resistance R_c is also equal to the input impedance of the noise meter.

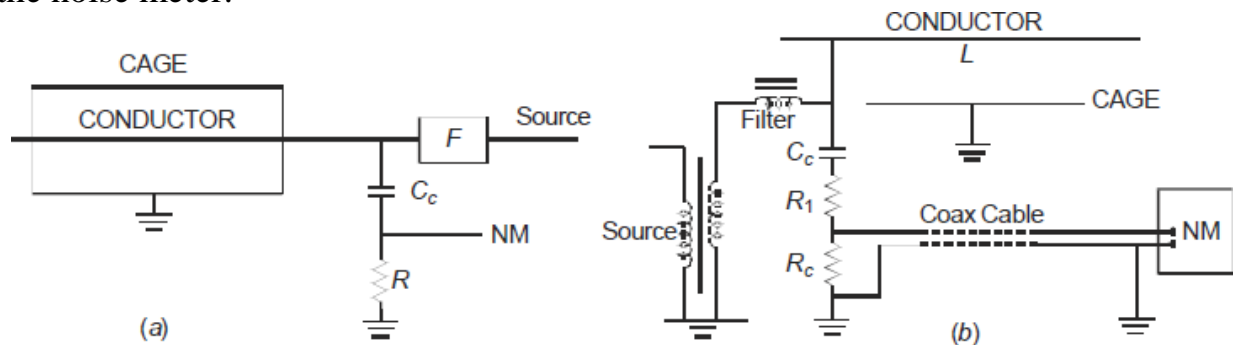

Fig. 3.8 Cage setups for measuring excitation function with measuring circuit.

UNIT-4

Electrostatic Fields

CALCULATION OF ELECTROSTATIC FIELD OF A.C. LINES

Power-Frequency Charge of Conductors

The method of calculating the electrostatic charges on the phase conductors from line dimensions and voltage. For n phases, this is, see Fig. 4.1, with q = total bundle charge and V = line to ground voltage.

$$\frac{1}{2\pi\epsilon_0}[q] = [P]^{-1}[V] = [M][V]$$

where

$$[q] = [q_1, q_2, q_3, \dots, q_n]_t$$

$$[V] = [V_1, V_2, V_3, \dots, V_n]_t$$

$[P]$ = $n \times n$ matrix of Maxwell's Potential coefficients with

$$P_{ii} = \ln(2H_i / r_{eq}) \text{ and } P_{ij} = \ln(I_{ij} / A_{ij}), i \neq j$$

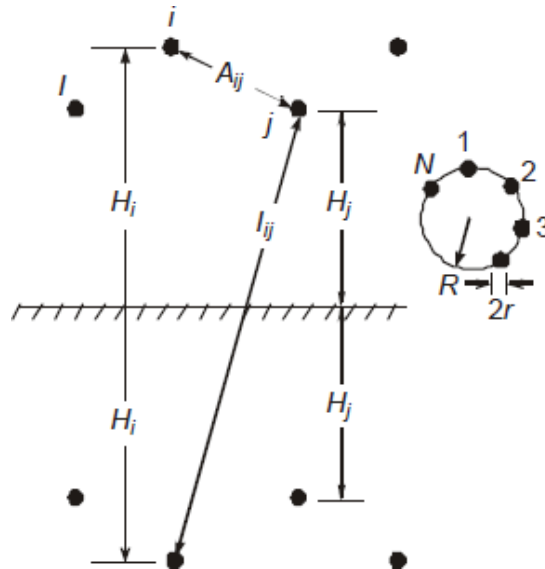

Fig. 4.1 n -phase line configuration for charge calculation.

EFFECT OF HIGH E.S. FIELD ON HUMANS, ANIMALS, AND PLANTS

The use of e.h.v. lines is increasing danger of the high e.s. field to (a) human beings, (b) animals, (c) plant life, (d) vehicles, (e) fences, and (f) buried pipe lines under and near these lines. When an object is located under or near a line, the field is disturbed, the degree of distortion depending upon the size of the object. It is a matter of some difficulty to calculate the characteristics of the distorted field, but measurements and experience indicate that the effect of the distorted field can be related to the magnitude of the undistorted field. A case-by-case study must be made if great accuracy is needed to observe the effect of the distorted field. The limits for the undistorted field will be discussed here in relation to the danger it poses.

(a) Human Beings

The effect of high e.s. field on human beings has been studied to a much greater extent than on any other animals or objects because of its grave and shocking effects which has resulted in loss of life. A farmer ploughing his field by a tractor and having an umbrella over his head for shade will be charged by corona resulting from pointed spikes. The vehicle is also charged when it is stopped under a transmission line traversing his field. When he gets off the vehicle and touches a grounded object, he will discharge himself through his body which is a pure resistance of about 2000 ohms. The discharge current when more than the let-go current can cause a shock and damage to brain. It has been ascertained experimentally that the limit for the undisturbed field is 15 kV/m, r.m.s., for human beings to experience possible shock. An e.h.v. or u.h.v. line must be designed such that this limit is not exceeded. The minimum clearance of a line is the most important governing factor. As an example, the B.P.A. of the U.S.A. have selected the maximum e.s. field gradient to be 9 kV/m at 1200 kV for their 1150 kV line and in order to do so used a minimum clearance at midspan of 23.2 m whereas they could have selected 17.2 m based on clearance required for switching-surge insulation recommended by the National Electrical Safety Council.

(b) Animals

Experiments carried out in cages under e.h.v. lines have shown that pigeons and hens are affected by high e.s. field at about 30 kV/m. They are unable to pick up grain because of chattering of their beaks which will affect their growth. Other animals get a charge on their bodies and when they proceed to a water trough to drink water, a spark usually jumps from their nose to the grounded pipe or trough.

(c) Plant Life

Plants such as wheat, rice, sugarcane, etc., suffer the following types of damage. At a field strength of 20 kV/m (r.m.s.), the sharp edges of the stalk give corona

discharges so that damage occurs to the upper portion of the grain-bearing parts. However, the entire plant does not suffer damage. At 30 kV/m, the by-products of corona, namely ozone and N₂O become intense. The resistance heating due to increased current prevents full growth of the plant and grain. Thus, 20 kV/m can be considered as the limit and again the safe value for a human being governs line design.

(d) Vehicles

Vehicles parked under a line or driving through acquire electrostatic charge if their tyres are made of insulating material. If parking lots are located under a line, the minimum recommended safe clearance is 17 m for 345 kV and 20 m for 400 kV lines. Trucks and lorries will require an extra 3 m clearance. The danger lies in a human being attempting to open the door and getting a shock thereby.

(e) Others

Fences, buried cables, and pipe lines are important pieces of equipment to require careful layout. Metallic fences parallel to a line must be grounded preferably every 75 m. Pipelines longer than 3 km and larger than 15 cm in diameter are recommended to be buried at least 30 m laterally from the line centre to avoid dangerous eddy currents that could cause corrosion. Sail boats, rain gutters and insulated walls of nearby houses are also subjects of potential danger. The danger of ozone emanation and harm done to sensitive tissues of a human being at high electric fields can also be included in the category of damage to human beings living near e.h.v. lines.

Travelling Wave Theory

On an electrical transmission line, the voltages, currents, power and energy flow from the source to a load located at a distance L , propagating as electro-magnetic waves with a finite velocity. Hence, it takes a short time for the load to receive the power. This gives rise to the concept of a wave travelling on the line which has distributed line parameters r , l , g , c per unit length. The current flow is governed mainly by the load impedance, the line-charging current at power frequency and the voltage. If the load impedance is not matched with the line impedance, which will be explained later on, some of the energy transmitted by the source is not absorbed by the load and is reflected back to the source which is a wasteful procedure.

However, since the load can vary from no load (infinite impedance) to rated value, the load impedance is not equal to the line impedance always; therefore, there always exist transmitted waves from the source and reflected waves from the load end. At every point on the intervening line, these two waves are present and the resulting voltage or current is equal to the sum of the transmitted and reflected

quantities. The polarity of voltage is the same for both but the directions of current are opposite so that the ratio of voltage to current will be positive for the transmitted wave and negative for the reflected wave. These can be explained mathematically and have great significance for determining the characteristics of load flow along distributed parameter line.

The same phenomenon can be visualized through standing waves. For example, consider an open-ended line on which the voltage must exist with maximum amplitude at the open end while it must equal the source voltage at the sending end which may have a different amplitude and phase. For 50 Hz, at light velocity of 300×10^3 km/sec, the wavelength is 6000 km, so that a line of length L corresponds to an angle of $(L \times 360^\circ/6000)$. With a load current present, an additional voltage caused by the voltage drop in the characteristic impedance is also present which will stand on the line. These concepts will be explained in detail by first considering a loss-less line ($r = g = 0$) and then for a general case of a line with losses present.

UNIT-5

Voltage Control

PROBLEMS AT POWER FREQUENCY

Power-frequency voltage is impressed on a system continuously as compared to transients caused by faults, lightning, and switching operations. Certain abnormal conditions arise when overvoltages of a sustained nature can exist in systems which have to be guarded against. Insulation levels will be governed by these, and it is very important to know all the factors

which contribute to such overvoltages. E.H.V. lines are longer than and their surge impedance lower than lines at 345 kV and lower voltages. Also, e.h.v. lines are used more for point-to point transmission so that when load is dropped, a large portion of the system is unloaded and voltage rise could be more severe than when there is a vast interconnected network. Due also to the high capacitance of e.h.v. lines possibility of self-excitation of generators is quite serious. Shunt reactors are employed to compensate the high charging current, which not only prevent overvoltages during load dropping but also improve conditions for load flow, and the risk of self excitation can also be counteracted. In order to improve conditions, variable static VAR systems can also be employed as well as switched capacitors which introduce harmonics into the system. Finally, the use of series capacitors to increase line loading in long lines might bring about the danger of subsynchronous resonance in which electrical conditions in generators can produce torques which correspond to the torsional frequencies of the shaft and result in mechanical damage.

The system at power frequency consists of lumped-parameter network elements connected to distributed-parameter transmission lines, and the calculations are best handled through generalized constants in matrix form.

SUB-SYNCHRONOUS RESONANCE PROBLEM AND COUNTER MEASURES

As pointed out before, electrical resonance frequencies lower than synchronous frequency f_0 exist when series-capacitor compensation is used. The frequency f_0 corresponds to the steady state speed of the rotor in large power stations. With steam-turbine-driven generating units (designated T.G. units), the shaft or shaft portions connecting the HP, IP, LP stages of the turbine and the generator-exciter

are very long, with their own characteristic torsional mechanical resonant frequencies. When the electrical system operates in such a manner that the rotating fields in the generator due to sub-synchronous currents produce torques of the same frequency as one of the mechanical torsional frequencies of the shaft and of the correct phase, torques up to 10 times the break away or ultimate strength of the shaft can be reached resulting in shaft damage. This phenomenon of electromechanical interaction between electrical resonant circuits of the transmission system and the torsional natural frequencies of the T-G rotor is known as "Sub-Synchronous Resonance", and designated SSR. The phenomenon of SSR has been studied very extensively since 1970 when a major transmission network in the U.S. experienced shaft failure to its T-G unit with series compensation in the 500 kV lines. This has now gone into technical literature as a classic problem and known as Project Navajo. The phenomenon, however, had been known to exist for a few years according to many experts who predicted such a phenomenon in series compensated lines connected to T-G units. As a result of extensive study of Project Navajo, countermeasures to combat the SSR problem have been designed and are operating successfully. The SSR failure must therefore be considered as one of the governing factors in design of series compensated lines when they are used for evacuating power from large thermal power stations. The combined cost of series-capacitor installation and the countermeasures is lower than the cost of additional transmission lines required when no series-compensation is used. Three distinct problems have been identified in SSR problem which are called

1. Induction Generator Effect,
2. Torsional Interaction, and
3. Transient Torque Problem.

The first two are known as steady-state problems while the last one occurs when system conditions change due to short-circuits and switching operations.

STATIC REACTIVE COMPENSATING SYSTEMS (STATIC VAR)

One type of reactor compensation for countering SSR was mentioned as a Dynamic Filter which uses thyristors to modulate the current through a parallel-connected reactor in response to rotor speed variation. The advent of high-speed high-current switching made possible by thyristors (silicon-controlled-rectifiers) has brought a new concept in providing reactive compensation for optimum system performance. Improvements obtained by the use of these static var compensators (SVC) or generators (SVG) or simply static var systems (SVS) are numerous, some of which are listed below:

1. When used at intermediate buses on long lines, the steady-state power-handling

capacity is improved.

2. Transient stability is improved.
3. Due to increased damping provided, dynamic system stability is improved.
4. Steady-state and temporary voltages can be controlled.
5. Load power factor can be improved thereby increasing efficiency of transmission and lowering of line losses.
6. Damping is provided for SSR oscillations.
7. Overall improvement is obtained in power-transfer capability and in increased economy.
8. The fast dynamic response of SVC's have offered a replacement to synchronous condensers having fast excitation response.