



Presentation For **FLEXIBLE MANUFACTURING SYSTEMS**

**DEPARTMENT OF MECHANICAL ENGINEERING
M.TECH – III SEM**

by

Mr. B.Vijaya Krishna

UNIT-I

FLEXIBLE MANUFACTURING SYSTEMS

❖ A flexible manufacturing system (FMS) is an arrangement of machines ... interconnected by a transport system. The transporter carries work to the machines on pallets or other interface units so that work-machine registration is accurate, rapid and automatic. A central computer controls both machines and transport system.

Or

❖ “FMS consists of a group of processing work stations interconnected by means of an automated material handling and storage system and controlled by integrated computer control system.”

❖ FMS is called flexible due to the reason that it is capable of processing a variety of different part styles simultaneously at the workstation and quantities of production can be adjusted in response to changing demand patterns

BASIC COMPONENTS OF FMS

The basic components of FMS are:

1. Workstations
2. Automated Material Handling and Storage system.
3. Computer Control System

1. Workstations: In present day application these workstations are typically computer numerical control (CNC) machine tools that perform machining operation on families of parts. Flexible manufacturing systems are being designed with other type of processing equipments including inspection stations, assembly works and sheet metal presses.

VARIOUS WORKSTATIONS

The various workstations are

1. Machining centers
2. Load and unload stations
3. Assembly work stations
4. Inspection stations
5. Forging stations
6. Sheet metal processing, etc.

2. Automated Material Handling and Storage system: The various automated material handling systems are used to transport work parts and subassembly parts between the processing stations, sometimes incorporating storage into function.

FUNCTIONS OF AUTOMATED MATERIAL HANDLING AND STORAGE SYSTEM ARE



The various functions of automated material handling and storage system are

1. Random and independent movement of work parts between workstations
 2. Handling of a variety of work part configurations
 3. Temporary storage
 4. Convenient access for loading and unloading of work parts
 5. Compatible with computer control.
3. Computer Control System: It is used to coordinate the activities of the processing stations and the material handling system in the FMS.

FUNCTIONS OF COMPUTER CONTROL

The various functions of computer control system are:

- (i) Control of each work station
- (ii) Distribution of control instruction to work station
- (iii) Production control
- (vi) Traffic control
- (v) Shuttle control
- (vi) Work handling system and monitoring
- (vii) System performance monitoring and

DIFFERENT TYPES OF FMS

The different types of FMS are

1. Sequential FMS
2. Random FMS
3. Dedicated FMS
4. Engineered FMS
5. Modular FMS

Sequential FMS: It manufactures one-piece part batch type and then planning and preparation is carried out for the next piece part batch type to be manufactured. It operates like a small batch flexible transfer line.

Random FMS: It manufactures any random mix of piece part types at any one time.

Dedicated FMS: It continually manufactures, for extended periods, the same but limited mix of piece part batch types.

Engineered FMS: It manufactures the same mix its lifetime

Modular FMS : modular FMS with a sophisticated FMS host, enables and FMS user to expand their FMS capabilities in a stepwise fashion into any of the previous four types of FMS.

UNIT OR JOB TYPE OF PRODUCTION:

This type of production is most commonly observed when you produce one single unit of a product.

A typical example of the same will be tailored outfits which are made just for you or a cake which is made just like you want it.

Example of Unit type of production

It is one of the most common types of [products](#) used because it is generally used by small businesses like restaurants, [individual](#) products providers or individual services providers.

It is also a type of production used by very premium companies like [Harley Davidson](#), or [Dell](#). Harley Davidson actually has a lot of accessories which can be customized, and which suit the individual. Same ways, you can design your own DELL laptop on their website with the given specifications.

Features of Unit production or Job Production :

1. Depends a lot on skill
2. Dependency is more on manual work than mechanical work
3. Customer service and customer management plays an important role

Batch type of Production:

It is one of the types of production most commonly used in consumer durables, FMCG or other such industries where there are large variety of products with variable demands. Batch production takes place in batches. The manufacturer already knows the number of units he needs to a manufacturer and they are manufactured in one batch.

So, if a manufacturer has the shortage of Product X and 100 units of this product is consumed in one month, then the manufacturer can give orders for batch production of 100 units of Product X.

Example of Batch production

LG has many different types of home appliance products in its portfolio. It has to manufacture all these different variants of the same type of product. There would be 10-20 types of mixer grinders alone in the product portfolio of LG home appliances. Thus, a company like LG manufactures these variants via Batch production. First, one type of mixer will be manufactured completely and then the second type will be manufactured. They are manufactured on the basis of demand. Depending on demand, the batch production can produce the number of units required in one batch.

Features of Batch production :

1. Production is done in batches.
2. The total number of units required is decided before the batch production starts
3. Once a batch production starts, stopping it midway may cost a huge amount to the company.
4. Demand plays a major role in a batch production. Example – seasonality of products.

Mass Production or Flow production

- One of the best examples of mass production is the manufacturing process adopted by [Ford](#).
- Mass production is also known as flow production or assembly line production.
- It is one of the most common types of products used in the [automobile](#) industry and is also used in industries where continuous production is required.
- An Assembly line or mass production plant typically focus on specialization.
- There are multiple workstations installed and the assembly line goes through all the workstations turn by turn.
- The work is done in a specialized manner and each workstation is responsible for one single type of work.
- As a result, these workstations are very efficient and production due to which the whole assembly line becomes productive and efficient.

- Products which are manufactured using mass production are very standardized products.
- High sophistication is used in the manufacturing of these products.
- If 1000 products are manufactured using mass production, each one of them should be exactly the same.
- There should be no deviation in the product manufactured.

Features of Mass Production

1. Mass production is generally used to dole out huge volumes of the product
2. It is used only if the product is standardized
3. Demand does not play a major role in a Mass production. However, production capacity determines the success of a mass production.
4. Mass production requires huge initial investment and the working capital demand is huge too.

Continuous production or Process production :

- There is a lot of confusion between mass production and continuous production.
- It can be differentiated by a single element.
- The amount of mechanical work involved.
- In Mass production, both machines and humans work in tandem.
- However, in continuous production, most of the work is done by machines rather than humans.
- In continuous production, the production is continuous, 24×7 hours, all days in a year.
- A good example of the Continuous production is brewing.
- In brewing, the production goes on 24 hours a day and 365 days a year. This is because brewing takes a lot of time and production is important.

- As a result, there is a continuous input of raw materials such as malt or water, and there is continuous output in the form of beer or other alcoholic drink.
- The key factor in this is that the brewing and fermentation process itself is time-consuming, and the maximum time is spent in the fermentation which is a continuous process
- There are many chemicals which are manufactured in the form of a continuous process due to the huge demand across the world. Similarly, the Plastic industry is known to adopt the continuous production methodology where production can go continuously for weeks or months depending on the demand.
- Once the production starts, you only need to feed in the raw material, and the machines turn out the finalized products.

Features of Continuous production :

1. Majority of the work is done by machines rather than humans
2. Work is continuous in nature.
3. Once production starts, it cannot be stopped otherwise it will cause huge loss.
4. A very controlled environment is required for continuous production

UNIT-II

SYSTEM MODELING ISSUES

Centralized Version Control

- A centralized version control system works on a client-server model. There is a single, (centralized) master copy of the code base, and pieces of the code that are being worked on are typically locked, (or “checked out”) so that only one developer is allowed to work on that part of the code at any one time.
- Access to the code base and the locking is controlled by the server. When the developer checks their code back in, the lock is released so it’s available for others to check out.
- Of course, an important part of any VCS is the ability to keep track of changes that are made to the code elements, and so when an element is checked in, a new version of that piece is created and logged although there have been many commercial examples (including IBM’s [Rational Clear Case](#)).

- When everyone has finished working on their different pieces and it's time to make a new release, a new version of the application is created, which usually just means logging the version numbers of all the individual parts that go together to make that version of the application.
- Probably the best known examples of centralized VCS systems are [CVS](#) and [Subversion](#), both of which are open source,

Distributed Version Control

- More recently, there's been a trend (or some might call it a revolution) toward distributed version control systems.
- These systems work on a peer-to-peer model: the code base is distributed amongst the individual developers' computers.
- In fact, the entire history of the code is mirrored on each system.
- There is still a master copy of the code base, but it's kept on a client machine rather than a server.
- There is no locking of parts of the code; developers make changes in their local copy and then, once they're ready to integrate their changes into the master copy, they issue a request to the owner of the master copy to merge their changes into the master copy.
- With a DVCS, the emphasis switches from versions to changes, and so a new version of the code is simply a combination of a number of different sets of changes

- That's quite a fundamental change in the way many developers work, which is why DVCS's are sometimes considered [harder to understand](#) than centralized systems.
- The best known examples of distributed VCS's are [Git](#) and [Mercurial](#), both of which are open source.

Pros and Cons :

The key difference between centralized and distributed VCS's, in my opinion, revolves around the fact that there is no locking of elements in a distributed system.

So every new set of changes that a developer makes is essentially like a new branch of the code, that needs to be merged back into the master repository.

In the distributed model, it's possible for two developers to be working on the same source file at the same time.

Real-time vs. Discrete-event Control System



- The use of digital or discrete technology to maintain conditions in operating systems as close as possible to desired values despite changes in the operating environment.
- Traditionally, control systems have utilized analog components, that is, controllers which generate time-continuous outputs (volts, pressure, and so forth) to manipulate process inputs and which operate on continuous signals from instrumentation measuring process variables (position, temperature, and so forth).
- In the 1970s, the use of discrete or logical control elements, such as fluidic components, and the use of programmable logic controllers to automate machining, manufacturing, and production facilities became widespread.
- In parallel with these developments has been the accelerating use of digital computers in industrial and commercial applications areas, both for logic-level control and for replacing analog control systems

- The development of inexpensive mini and microcomputers with arithmetic and logical capability orders of magnitude beyond that obtainable with analog and discrete digital control elements has resulted in the rapid substitution of conventional control systems by digital computer-based ones.
- With the introduction of computer-based control systems into major consumer products areas (such as automobiles and video and audio electronics), it is clear that the digital computer will be widely used to control objects ranging from small, personal appliances and games up to large, commercial manufacturing and production facilities.

Real-time control system

- Real-time control system means that the control system must provide the control responses or actions to the stimulus or requests within specific times, which therefore depend not just on what the system does but also on how fast it reacts.
 - In software, each of the stimulus handlers requires a process (or task).
 - Actually, a real-time control system normally consists of these three types of processes:
 - (1) Sensor control processes that collect information from sensors and may buffer information collected in response to a sensor stimulus.
 - (2) Data processor carrying out processing of collected information and computing the system response.
 - (3) Actuator control processes that generate control signals for actuators.
- Real-time control systems are usually designed in the software as cooperating processes with an executive concurrently controlling these processes.

Forward vs. backward scheduling approaches

Forward Scheduling :

- Forward scheduling is when businesses complete manufacturing their items as soon as possible before the due date.
- This is achieved by scheduling the relevant resources and materials as soon as they're available.
- Let's quickly use an example like, if a customer orders an item with a delivery date which is six days away and the lead time for the item is three days.
- Production begins as soon as the manufacturing order is created and the item should be ready three days before it is due (assuming there are no snags along the way).

- However, orders might become fulfilled long before they're required to be dispatched as the resources or materials are utilized as early as possible meaning you're going to have to hold the products in inventory until you can dispatch them

In simple terms:

Forward scheduling = figuring out the earliest time you can complete a customer's order

Advantages of Forward Scheduling

There are two notable advantages to using forward production, and these are;

- 1. High labor utilization rate .**
- 2. Minimize slack time by redistributing resources during unexpected workloads**

Disadvantages of Forward Scheduling

There are several disadvantages to forward production:

1. The material is consumed in advance
2. Lead times increase
3. Difficult to rush production
4. Meeting deadlines on-time decreases
5. Difficult to schedule customized goods

Backward Scheduling:

- Backward scheduling is when businesses make their items at the last possible available time period before the due date.
- The order starts with a planned receipt date or due date - one which is usually defined upon the customer's order. Then you work backward, allocating resources and materials to the order, and then determine the latest time you can start.

To keep it simple we'll use the same example as before. A customer orders an item with a delivery date which is six days away and the lead time is three days.

From the due date, a manufacturer will figure out when they can start manufacturing. So, if the 6th day is the due date and the lead time is three days, that means the production of the item will begin on the 3rd day.

Using back scheduling can help you with identifying bottlenecks, monitor resource availability and have an easier time completing tasks in priority.

Once again, but to simplify back scheduling:

Backward scheduling = calculating the start date for operations depending on the availability of resources and material from the due date.

Advantages of Backward Scheduling

The benefits for small business manufacturers who want to utilize backward scheduling are:

1. Lower costs
2. Less risk

Disadvantages of Backward Scheduling

1. No buffer time
2. Fulfilling orders
3. Delaying work orders

MODELING OF ABSORBING STATES AND DEADLOCKS

- In the mathematical theory of [probability](#), an **absorbing Markov chain** is a [Markov chain](#) in which every state can reach an absorbing state.
- An absorbing state is a state that, once entered, cannot be left.
- A Markov chain is an absorbing chain if there is at least one [absorbing state](#) and it is possible to go from any state to at least one absorbing state in a finite number of steps.
- In an absorbing Markov chain, a state that is not absorbing is called transient.

Let an absorbing Markov chain with transition matrix P have t transient states and r absorbing states. Then

$$P = \begin{pmatrix} Q & R \\ \mathbf{0} & I_r \end{pmatrix},$$

where Q is a t -by- t matrix, R is a nonzero t -by- r matrix, $\mathbf{0}$ is an r -by- t zero matrix, and I_r is the r -by- r identity matrix. Thus, Q describes the probability of transitioning from some transient state to another while R describes the probability of transitioning from some transient state to some absorbing state.

Deadlock is a situation where a set of processes are blocked because each process is holding a resource and waiting for another resource acquired by some other process.

Consider an example when two trains are coming toward each other on same track and there is only one track, none of the trains can move once they are in front of each other.

Similar situation occurs in operating systems when there are two or more processes hold some resources and wait for resources held by other(s).

For example, in the below diagram, Process 1 is holding Resource 1 and waiting for resource 2 which is acquired by process 2, and process 2 is waiting for resource

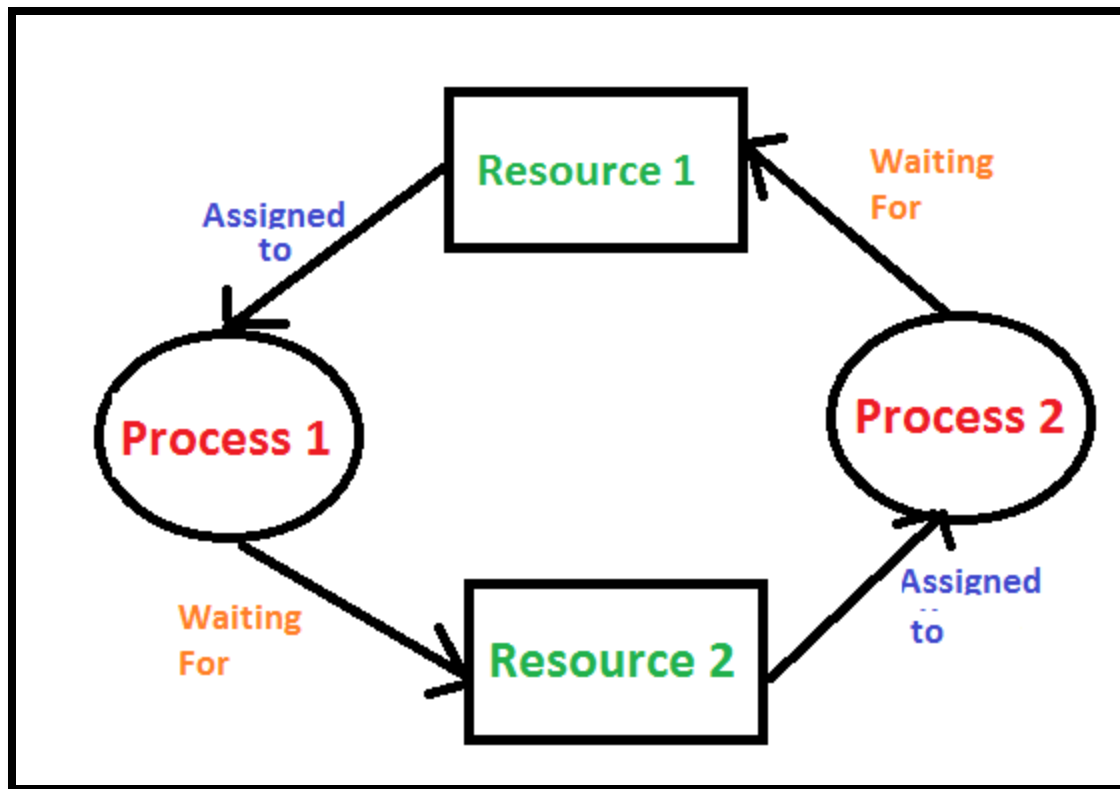

CONFLICTS

- **Conflict resolution strategies** are used in production systems in artificial intelligence, such as in rule-based expert systems, to help in choosing which production rule to fire. The need for such a strategy arises when the conditions of two or more rules are satisfied by the currently known facts.
- Conflict resolution strategies fall into several main categories. They each have advantages which form their rationales.
Specificity - If all of the conditions of two or more rules are satisfied, choose the rule according to how specific its conditions are. It is possible to favor either the more general or the more specific case. The most specific may be identified roughly as the one having the greatest number of preconditions. This usefully catches exceptions and other special cases before firing the more general (default) rules. [\[2\]](#)

Recency - When two or more rules could be chosen, favor the one that matches the most recently added facts, as these are most likely to describe the current situation.

Not previously used - If a rule's conditions are satisfied, but previously the same rule has been satisfied by the same facts, ignore the rule. This helps to prevent the system from entering infinite loops.

Order - Pick the first applicable rule in order of presentation.

This is the strategy that [Prolog](#) interpreters use by default, but any strategy may be implemented by building suitable rules in a Prolog system.

Arbitrary choice - Pick a rule at random. This has the merit of being simple to compute.

- **Concurrent design and manufacturing** involves simultaneously completing design and manufacturing stages of production.
- By completing the design and manufacturing stages at the same time, products are produced in less time while lowering cost. Although concurrent design and manufacturing requires extensive communication and coordination between disciplines, the benefits can increase the profit of a business and lead to a sustainable environment for product development.
- Concurrent design and manufacturing can lead to a competitive advantage over other businesses as the product maybe produced and marketed in less time.

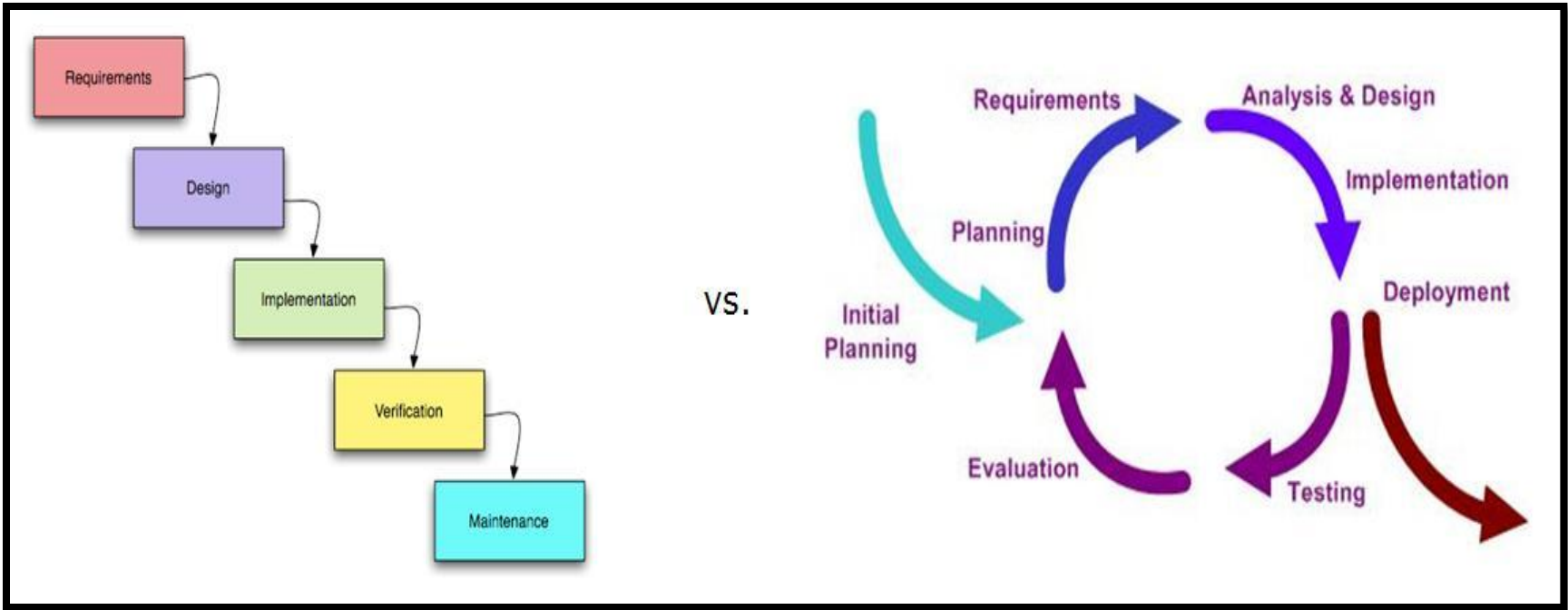

Synchronization :

The term 'synchronization' in manufacturing refers to the provision of the right components to the subsequent production steps at the right moment in time.

It is widely assumed that synchronization is beneficial to the logistics performance of manufacturing systems.

However, it has been shown that synchronization phenomena can be detrimental to systems in which they emerge

UNIT-III

SYSTEM MODELING TOOLS AND TECHNIQUES

- ❑ Mathematical modeling is the art of translating problems from an application area into tractable mathematical formulations whose theoretical and numerical analysis provides insight, answers, and guidance useful for the originating application.
- ❑ Mathematical modeling
 - is indispensable in many applications
 - is successful in many further applications
 - gives precision and direction for problem solution
 - enables a thorough understanding of the system modeled
 - prepares the way for better design or control of a system
 - allows the efficient use of modern computing capabilities
- ❑ Learning about mathematical modeling is an important step from a theoretical mathematical training to an application-oriented mathematical expertise, and makes the student fit for mastering the challenges of our modern technological culture.

Deterministic vs. stochastic models

- In deterministic models, the output of the model is fully determined by the parameter values and the initial conditions.
 - Stochastic models possess some inherent randomness. The same set of parameter values and initial conditions will lead to an ensemble of different outputs.
 - Obviously, the natural world is buffeted by stochasticity stochasticity.

But, stochastic models are considerably considerably more complicated. When do deterministic models provide a useful approximation to truly stochastic processes?

Discrete event simulation :

Discrete event simulation is a modeling approach widely used in decision support tools for logistics and supply chain management. In the context of [biomass supply chains](#), an early work was presented by Nilsson and Hansson, who developed a simulation model for a [biomass supply chain](#) of two feedstocks, straw and reed canary grass, for use in district heating applications (Nilsson and Hansson, 2001).

This discrete event simulation model aimed at satisfying a daily average heating demand load, and the authors concluded that a 15–20% cost reduction can be achieved when using two biomass types instead of one, due to increased efficiency of the [biomass utilization](#) network.

- **Monte Carlo methods**, or **Monte Carlo experiments**, are a broad class of computational algorithms that rely on repeated random sampling to obtain numerical results.
- The underlying concept is to use randomness to solve problems that might be deterministic in principle.
- They are often used in physical and mathematical problems and are most useful when it is difficult or impossible to use other approaches.
- Monte Carlo methods are mainly used in three problem classes: optimization, numerical integration, and generating draws from a probability distribution.

- In physics-related problems, Monte Carlo methods are useful for simulating systems with many coupled degrees of freedom, such as fluids, disordered materials, strongly coupled solids, and cellular structures (see cellular Potts model, interacting particle systems, McKean–Vlasov processes, kinetic models of gases).
- Other examples include modeling phenomena with significant uncertainty in inputs such as the calculation of risk in business and, in mathematics, evaluation of multidimensional definite integrals with complicated boundary conditions. In application to systems engineering problems (space, oil exploration, aircraft design, etc.), Monte Carlo–based predictions of failure, cost overruns and schedule overruns are routinely better than human intuition or alternative "soft" methods.

- In principle, Monte Carlo methods can be used to solve any problem having a probabilistic interpretation.
- By the law of large numbers, integrals described by the expected value of some random variable can be approximated by taking the empirical mean (a.k.a. the sample mean) of independent samples of the variable.
- When the probability distribution of the variable is parameterized, mathematicians often use a Markov chain Monte Carlo (MCMC) sampler.
- The central idea is to design a judicious Markov chain model with a prescribed stationary probability distribution.
- That is, in the limit, the samples being generated by the MCMC method will be samples from the desired (target) distribution.
- By the ergodic theorem, the stationary distribution is approximated by the empirical measures of the random states of the MCMC sampler.

MARKOV CHAIN

- A Markov chain is a stochastic model describing a sequence of possible events in which the probability of each event depends only on the state attained in the previous event
- In probability theory and related fields, a Markov process, named after the Russian mathematician Andrey Markov, is a stochastic process that satisfies the Markov property (sometimes characterized as "memorylessness").
- Roughly speaking, a process satisfies the Markov property if one can make predictions for the future of the process based solely on its present state just as well as one could knowing the process's full history, hence independently from such history, that is, conditional on the present state of the system, its future and past states are independent.

- A Markov chain is a type of Markov process that has either a discrete state space or a discrete index set (often representing time), but the precise definition of a Markov chain varies.
- For example, it is common to define a Markov chain as a Markov process in either discrete or continuous time with a countable state space (thus regardless of the nature of time), but it is also common to define a Markov chain as having discrete time in either countable or continuous state space (thus regardless of the state space).
- Markov studied Markov processes in the early 20th century, publishing his first paper on the topic in 1906.
- Random walks based on integers and the gambler's ruin problem are examples of Markov processes.

- Some variations of these processes were studied hundreds of years earlier in the context of independent variables.
- Two important examples of Markov processes are the Wiener process, also known as the Brownian motion process, and the Poisson process, which are considered the most important and central stochastic processes in the theory of stochastic processes, and were discovered repeatedly and independently, both before and after 1906, in various settings.
- These two processes are Markov processes in continuous time, while random walks on the integers and the gambler's ruin problem are examples of Markov processes in discrete time.
- Markov chains have many applications as statistical models of real-world processes, such as studying cruise control systems in motor vehicles, queues or lines of customers arriving at an airport, exchange rates of currencies, storage systems such as dams, and population growths of certain animal species.

- The algorithm known as PageRank, which was originally proposed for the internet search engine Google, is based on a Markov process
- Markov processes are the basis for general stochastic simulation methods known as Markov chain Monte Carlo, which are used for simulating sampling from complex probability distributions, and have found extensive application in Bayesian statistics.
- The adjective *Markovian* is used to describe something that is related to a Markov process.

Markov Process

- A stochastic process is a sequence of events in which the outcome at any stage depends on some probability.
- A Markov process is a stochastic process with the following properties:
 - (a.) The number of possible outcomes or states is finite.
 - (b.) The outcome at any stage depends only on the outcome of the previous stage.
 - (c.) The probabilities are constant over time.
- If x_0 is a vector which represents the initial state of a system, then there is a matrix M such that the state of the system after one iteration is given by the vector Mx_0 . Thus we get a chain of state vectors: x_0, Mx_0, M^2x_0, \dots where the state of the system after n iterations is given by $M^n x_0$. Such a chain is called a Markov chain and the matrix M is called a transition matrix.

- The state vectors can be of one of two types: an absolute vector or a probability vector.
- An absolute vector is a vector whose entries give the actual number of objects in a give state, as in the first example.
- A probability vector is a vector where the entries give the percentage (or probability) of objects in a given state.
- We will take all of our state vectors to be probability vectors from now on. Note that the entries of a probability vector addup to 1.

Theorem

Let M be the transition matrix of a Markov process such that M^k has only positive entries for some k . Then there exists a unique probability vector x_s such that $Mx_s = x_s$. Moreover $\lim_{k \rightarrow \infty} M^k x_0 = x_s$ for any initial state probability vector x_0 . The vector x_s is called a the steady-state vector

Transition Matrix and its Steady-State Vector

2. THE TRANSITION MATRIX AND ITS STEADY-STATE VECTOR

The transition matrix of an n -state Markov process is an $n \times n$ matrix M where the i, j entry of M represents the probability that an object in state j transitions into state i , that is if $M = (\mathbf{m}_{ij})$ and the states are S_1, S_2, \dots, S_n then \mathbf{m}_{ij} is the probability that an object in state S_j transitions to state S_i .

What remains is to determine the steady-state vector. Notice that we have the chain of equivalences:

$$M\mathbf{x}_s = \mathbf{x}_s \Leftrightarrow M\mathbf{x}_s - \mathbf{x}_s = \mathbf{0} \Leftrightarrow M\mathbf{x}_s - I\mathbf{x}_s = \mathbf{0} \Leftrightarrow (M - I)\mathbf{x}_s = \mathbf{0} \Leftrightarrow \mathbf{x}_s \in N(M - I)$$

Thus \mathbf{x}_s is a vector in the nullspace of $M - I$. If M^k has all positive entries for some k , then $\dim(N(M - I))=1$

and any vector in $N(M - I)$ is just a scalar multiple of \mathbf{x}_s . In particular if $\mathbf{x} = \begin{pmatrix} x_1 \\ \vdots \\ x_n \end{pmatrix}$ is any non-zero vector in

$N(M - I)$, then $\mathbf{x}_s = \frac{1}{c}\mathbf{x}$ where $c = x_1 + \dots + x_n$.

Example:

A certain protein molecule can have three configurations which we denote as C_1, C_2 and C_3 . Every second the protein molecule can make a transition from one configuration to another configuration with the following probabilities:

$$\begin{aligned} C_1 &\rightarrow C_2, P = 0.2 & C_1 &\rightarrow C_3, P = 0.5 \\ C_2 &\rightarrow C_1, P = 0.3 & C_2 &\rightarrow C_3, P = 0.2 \\ C_3 &\rightarrow C_1, P = 0.4 & C_3 &\rightarrow C_2, P = 0.2 \end{aligned}$$

Find the transition matrix M and steady-state vector \mathbf{x}_s for this Markov process.

Recall that $M = (\mathbf{m}_{ij})$ where \mathbf{m}_{ij} is the probability of configuration C_j making the transition to C_i . Therefore

$$M = \begin{pmatrix} 0.3 & 0.3 & 0.4 \\ 0.2 & 0.5 & 0.2 \\ 0.5 & 0.2 & 0.4 \end{pmatrix} \text{ and } M - I = \begin{pmatrix} -0.7 & 0.3 & 0.4 \\ 0.2 & -0.5 & 0.2 \\ 0.5 & 0.2 & -0.6 \end{pmatrix}$$

Now we compute a basis for $N(M - I)$ by putting $M - I$ into reduced echelon form:

$$U = \begin{pmatrix} 1 & 0 & -0.8966 \\ 0 & 1 & -0.7586 \\ 0 & 0 & 0 \end{pmatrix} \text{ and we see that } \mathbf{x} = \begin{pmatrix} 0.8966 \\ 0.7586 \\ 1 \end{pmatrix} \text{ is the basis vector for } N(M - I)$$

Consequently, $c = 2.6552$ and $\mathbf{x}_s = \begin{pmatrix} 0.3377 \\ 0.2857 \\ 0.3766 \end{pmatrix}$ is the steady-state vector of this process.

Note also that the nullspace of $M - I$ can be found using MATLAB and the function `null()`:

$$\begin{aligned} \mathbf{x} &= \text{null}(M - \text{eye}(3)) \\ \mathbf{x}_s &= \mathbf{x} / \text{sum}(\mathbf{x}) \end{aligned}$$

- In queueing theory, a discipline within the mathematical theory of probability, an M/M/1 queue represents the queue length in a system having a single server, where arrivals are determined by a Poisson process and job service times have an exponential distribution.
- The model name is written in Kendall's notation.
- The model is the most elementary of queueing models and an attractive object of study as closed-form expressions can be obtained for many metrics of interest in this model.
- An extension of this model with more than one server is the M/M/c queue.

- ❑ An M/M/1 queue is a stochastic process whose state space is the set $\{0,1,2,3,\dots\}$ where the value corresponds to the number of customers in the system, including any currently in service.
 - Arrivals occur at rate λ according to a Poisson process and move the process from state i to $i + 1$.
 - Service times have an exponential distribution with rate parameter μ in the M/M/1 queue, where $1/\mu$ is the mean service time.
 - A single server serves customers one at a time from the front of the queue, according to a first-come, first-served discipline. When the service is complete the customer leaves the queue and the number of customers in the system reduces by one.
 - The buffer is of infinite size, so there is no limit on the number of customers it can contain.

The model can be described as a continuous time Markov chain with transition rate matrix

$$Q = \begin{pmatrix} -\lambda & \lambda & & & & \\ \mu & -(\mu + \lambda) & \lambda & & & \\ & \mu & -(\mu + \lambda) & \lambda & & \\ & & \mu & -(\mu + \lambda) & \lambda & \\ & & & \mu & -(\mu + \lambda) & \lambda \\ & & & & \ddots & \ddots \end{pmatrix}$$

on the state space $\{0, 1, 2, 3, \dots\}$. This is the same continuous time Markov chain as in a birth-death process. The state space diagram for this chain is as below.

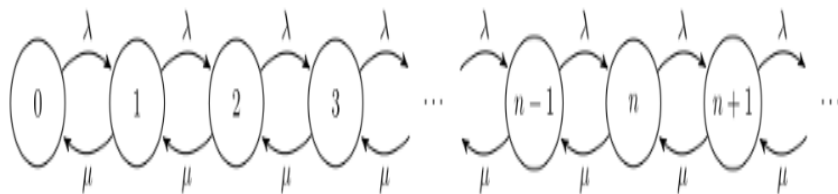

PETRI NET

- A **Petri net**, also known as a **place/transition (PT) net**, is one of several **mathematical modeling languages** for the description of **distributed systems**. It is a class of **discrete event dynamic system**.
- A Petri net is a directed **bipartite graph**, in which the nodes represent transitions (i.e. events that may occur, represented by bars) and places (i.e. conditions, represented by circles).
- The directed arcs describe which places are pre- and/or postconditions for which transitions (signified by arrows).
- Some sources[[] state that Petri nets were invented in August 1939 by **Carl Adam Petri**—at the age of 13—for the purpose of describing chemical processes.

PETRI NET

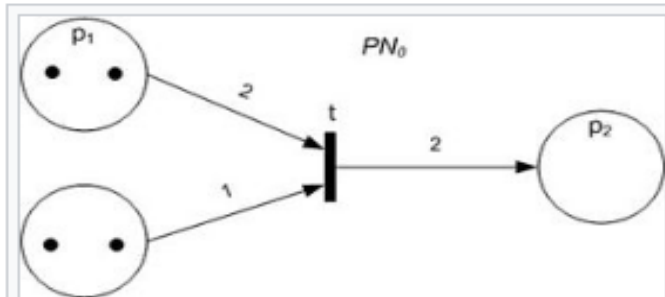

A Petri net with an enabled transition.

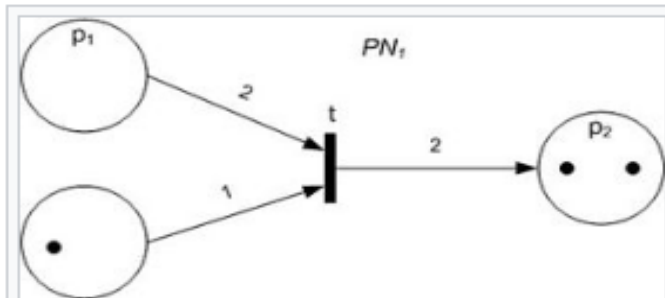

The Petri net that follows after the transition fires (Initial Petri net in the figure above).



- Like industry standards such as UML activity diagrams, Business Process Model and Notation and EPCs, Petri nets offer a graphical notation for stepwise processes that include choice, iteration, and concurrent execution.
- Unlike these standards, Petri nets have an exact mathematical definition of their execution semantics, with a well-developed mathematical theory for process analysis.
- A Petri net consists of *places*, *transitions*, and *arcs*. Arcs run from a place to a transition or vice versa, never between places or between transitions. The places from which an arc runs to a transition are called the *input places* of the transition; the places to which arcs run from a transition are called the *output places* of the transition.

- Graphically, places in a Petri net may contain a discrete number of marks called tokens.
- Any distribution of tokens over the places will represent a configuration of the net called a marking.
- In an abstract sense relating to a Petri net diagram, a transition of a Petri net may fire if it is enabled, i.e. there are sufficient tokens in all of its input places; when the transition fires, it consumes the required input tokens, and creates tokens in its output places.
- A firing is atomic, i.e. a single non-interruptible step.
- Unless an execution policy[example needed] is defined, the execution of Petri nets is nondeterministic: when multiple transitions are enabled at the same time, they will fire in any order.
- Since firing is nondeterministic, and multiple tokens may be present anywhere in the net (even in the same place), Petri nets are well suited for modeling the concurrent behavior of distributed systems.

UNIT-IV

PERFORMANCE ANALYSIS

Performance Analysis

- ❑ Automated guided vehicle systems consists of the computer, software and technology that are the “brains” behind the AGV. Without computer software systems and communications networks, only the simplest AGV functions can be performed
- ❑ The analysis of AGV systems is used to determine
 - (i) the number of AGV’s required
 - (ii) cycle times
 - (iii) handling system efficiency
- ❑ It is assumed that the vehicle operates at a constant speed of V .
- ❑ The acceleration, deceleration and other effects that influence the speed are ignored.
- ❑ The time for a typical delivery cycle in the operation of the vehicle includes
 1. loading at the pick up station
 2. unloading at the drop off stations
 3. travel time to the drop off station
 4. empty travel time of the vehicle between deliveries

Therefore the total cycle time per delivery per vehicle is given by

$$T_v = T_l + T_u + Ld/v + Le/v$$

Where, T_v = Delivery cycle time (min./delivery)

T_l = Pick up time (min.)

T_u = Drop off time (min.)

$T_h = T_l + T_u$ = Handling time (min)

Ld = Distance the vehicle travels between load and unload station (m)

Le = Distance the vehicle travels empty until the start of next delivery cycle (m)

v = velocity (m/min.)

The delivery cycle time can be used to determine the rate of deliveries per vehicle and number of vehicles required.

The hourly rate of deliveries per vehicle is 60 minutes divided by the delivery cycle time T_v , with adjusting for any time losses during the hour.

The possible time losses include *availability, traffic congestion and efficiency of manual drivers.*

∴ Traffic factor (F_t) accounts and lies between 0.85 and 1.

∴ Number of deliveries per hour per vehicle = $60 F_t/T_v$

or

Number of deliveries per hour per vehicle = $(60 E_h)/(Ld/v)$

Where E_h = handling system efficiency

$$= \{(Ld/v) \times F_t\}/(Ld/v + T_h + Le/v)$$

∴ Number of AGVs required = $\frac{\text{Number of deliveries required per hour}}{\text{Number of deliveries/hour/vehicle}}$

Example 8.1 Following are the data of AGV system:

Vehicle Velocity = 45 m/min.

Average distance traveled/delivery = 135m

Pick up time = 45 sec.

Drop off time = 45sec.

Average distance traveling empty = 90 m

Traffic factor = 0.9

Determine the number of vehicles required to satisfy the delivery demand if the delivery demand is 40 deliveries per hour. Also determine the handling system efficiency.

Solution: $Ld = 135$ m, $Le = 90$ m, $Tl = 45$ sec = 0.75 min, $Tu = 45$ sec = 0.75 min, $Th = Tl + Tu$
 $= 0.75$ min. + 0.75 min
 $= 1.5$ min.,
 $v = 45$ m/min. and $Ft = 0.9$

Total cycle time per delivery per vehicle is given by

$$Tv = Th + Ld/v + Le/v$$

$$= 0.75 + 0.75 + 135/45 + 90/45$$

$$= 6.45 \text{ min.}$$

The number of delivery per hour per vehicle = $60 Ft/Tv$

$$= 60 \times 0.9/6.45$$

$$= 8.37 \text{ deliveries/hour/vehicle}$$

$$\text{Number of vehicles required} = \frac{\text{Number of deliveries required per hour}}{\text{Number of deliveries/hour/vehicle}}$$

$$= \frac{40 \text{ delivery/hour}}{8.37 \text{ deliveries/hour/vehicle}}$$

$$= 4.82$$

$$= 5 \text{ vehicles}$$

$$\text{Handling system efficiency} = \frac{\{(Ld/v) \times Ft\}}{\{(Ld/v) + Th + (Le/v)\}}$$

$$= \frac{\{(135/45) \times 0.9\}}{\{(135/45) + 1.5 + (90/45)\}}$$

$$= 0.4154$$

$$= 41.54 \%$$

Example 8.2 In order to determine the number of vehicles required to meet the demand for a particular automated guided vehicle system. The system must be capable of making 40 deliveries per hour. The following are the data of performance characteristics of the system:

Vehicle velocity = 150 m/min.

Average distance traveled per delivery = 450 m

Pick up time = 0.75 min.

Drop off time = 0.75 min.

Average distance traveling empty = 300 m

Traffic factor = 0.9

Determine the number of vehicles required to meet the demand of delivery. Also determine the handling system efficiency?

Solution: The total time per delivery per vehicle is given by

$$\begin{aligned} T_v &= T_h + Ld/v + Lc/v \\ &= T_l + T_u + Ld/v + Le/v \\ &= 0.75 + 0.75 + 450/150 + 300/150 \\ &= 3 + 1.5 + 2 \\ &= 6.5 \text{ min.} \end{aligned}$$

The number of deliveries per hour per vehicle = $60 Ft/T_v$

$$= 60 (0.9)/6.5$$

$$= 8.3077 \text{ deliveries/hour/vehicle}$$

Therefore, the number of vehicles required

$$= \frac{\text{Number of deliveries required per hour}}{\text{Number of deliveries/hour/vehicle}}$$

$$= 40/8.3077$$

$$= 4.81 \text{ vehicles}$$

$$= 5 \text{ vehicles}$$

The handling system efficiency,

$$\begin{aligned} E_h &= \{(Ld/v) * Ft\} / \{(Ld/v) + T_h + (Le/v)\} \\ &= \{(450/150) * 0.9\} / \{(450/150) + 1.5 + (300/150)\} \\ &= 0.41538 \\ &= 41.54 \% \end{aligned}$$

Analysis Of Automated Storage And Retrieval Systems

AUTOMATED STORAGE AND RETRIEVAL SYSTEMS (AS/RS)

Automated Storage and Retrieval Systems (ASRS) are means to high density, hands free buffering of materials in distribution and manufacturing environments. There are several classes of Automated Storage and Retrieval (AS/RS) that are characterized by weight and size handling characteristics.

- Unit Load AS/RS
- Mini Load AS/RS
- Carousel AS/RS

- ❑ The analysis of AS/RS is used in order to determine the transaction cycle time.
- ❑ The transaction cycle involves retrieval of load out of storage or delivery of a load in to the storage or both of the activities in a single cycle.
- ❑ The two types of transaction cycles are:
 1. Single command cycle: It involves either retrieving a load from the storage or entering a load into the storage but not both in a single cycle.
 2. Dual command cycle: It involves both entering a load into storage and retrieval of the load from storage in the same cycle. It represents the most efficient way to operate the AS/RS since two loads are handled in a single transaction.

In order to compute the transaction cycle time based on the formulas derived by Bozer and White following assumptions have to be made

- Randomized storage of loads in AS/RS
- Storage compartments are of same size
- Pickup and delivery station is located at the base and end of the aisle
- Horizontal and vertical speed of the storage/retrieval (S/R) machine are constant
- Simultaneous horizontal and vertical travel

For single command cycle, the transaction time is given by,

$$T_{sc} = T (Q^2/3 + 1) + 2 T_{pd}$$

For dual command cycle, the transaction time is given by,

$$T_{dc} = T (4/3 + 0.5 Q^2 - Q^3/30) + 4 T_{pd}$$

Where, L_s = Length of aisle

H_s = Height of aisle

V_h = Average horizontal speed of S/R machine

V_v = Average vertical speed of S/R machine

T_{pd} = shuttle time to perform pickup and deposit.

The time required for horizontal and vertical travel in full length and height of the storage system are given by

$$t_h = L_s/V_h$$

and

$$t_v = H_s/V_v$$

Using these travel times, the following parameters are defined,

$$T = \max (t_h, t_v)$$

$$Q_{\min} = \min (t_h/T, t_v/T)$$

Quantitative Analysis

QUANTITATIVE ANALYSIS

The size and capacity of a storage carousel can be determined with reference to the given Fig. 8.21. The individual bins are hung on carriers that revolve around the carousel track. The circumference of the carousel track is given by

$$C = 2(Ls - Ws) + \pi Ws \quad \dots (8.12)$$

Consider the spacing between carriers around the track be given by s_c and the number of carriers be symbolized as n_c .

$$\text{Hence } n_c s_c = C \quad \dots (8.13)$$

If the number of separate bins hung from a carrier is n_b , the total number of bins that is storage compartments on the carousel = $n_c n_b$... (8.14)

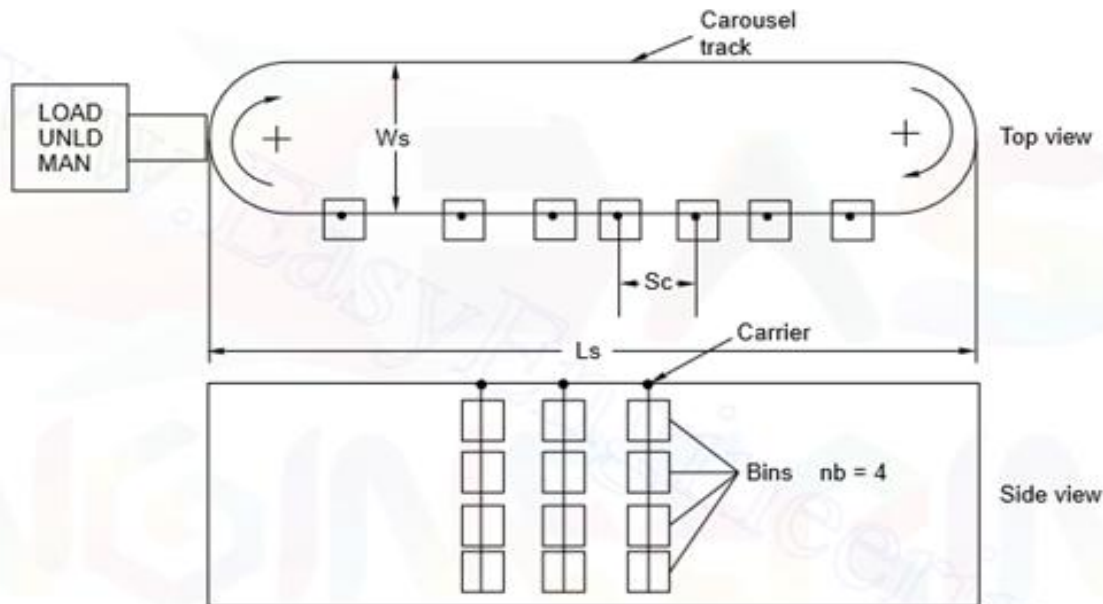

Fig. 8.21 Layout and elevation drawing of a typical storage carousel

- Let us consider a retrieval cycle and the storage transaction is performed under the same assumption of random storage would be equivalent to a retrieval transaction.
- The average distance that the carousel has to travel to move randomly located bin to the unload station at the end of the carousel depends on whether the carousel revolves in only one or both directions.
- For the single direction, the average travel distance is given by

$$L_r = 0.5C$$

And the corresponding time complete a retrieval transaction,

$$T_r = (0.5C/V_c) + T_h$$

Where T_h —handling time of the picker to remove the item or items from the bin. For the carousel capable of bi-directional travel, the corresponding average travel distance and retrieval transaction time are

$$L_r = 0.25C$$

$$T_r = (0.25C/V_c) + T_c$$

Example 8.3 Consider an operation of unit load AS/RS, which uses an S/R machine for each aisle of the system. The length of storage aisle is 300 m and its height is 50 m. Horizontal and vertical speeds of S/R machine are 400 m/min. and 75m/min. respectively. The S/R require 30 seconds to accomplish pickup and delivery. Determine the single and dual command cycle times.

Solution: The values of t_h and t_v are

$$\begin{aligned} t_h &= L_s/V_h \\ &= 300 \text{ m}/400 \text{ m/min} \\ &= 0.75 \text{ min.} \end{aligned}$$

$$\begin{aligned} t_v &= H_s/V_v \\ &= 50 \text{ m}/75 \text{ m/min} \\ &= 0.667 \text{ min.} \end{aligned}$$

The parameter T and Q are determined as

$$\begin{aligned} T &= \max(t_h, t_v) \\ &= \max(0.75, 0.667) \\ &= 0.75 \text{ min.} \end{aligned}$$

$$\begin{aligned} Q &= \min(t_h/T, t_v/T) \\ &= \min(0.75/0.75, 0.667/0.75) \\ &= 0.889 \text{ min.} \end{aligned}$$

Therefore single command transaction cycle time is given by:

$$\begin{aligned} T_{sc} &= T(Q^2/3 + 1) + 2 T_{pd} \\ &= 0.75 \{(0.889)^2/3 + 1\} + 2 (30/60) \\ &= 1.9475 \text{ min.} \end{aligned}$$

Example 8.4: The oval of a top-driven carousel track has a length = 50m and width = 4m. The speed of the carousel = 75 m/min. There are 100 carriers around the carousel and each carrier has 5 bins suspended from it. For a single direction carousel and a bidirectional carousel, compare how long it takes to retrieve 20 parts from the carrier if each part is in different storage bin and random storage is used in the carousel. Also determine the spacing between carriers and carousel. The handling time associated with retrieval is 20 seconds.

Solution: The circumference of the carousel track is

$$C = 2 \times (50 - 4) + 4\pi$$

$$= 104.57$$

For single direction carousel, the retrieval of 20 parts would require

$$20Tr = 20 \times (0.5 \times (104.57/75) + 0.333)$$

$$Tr = 20.61 \text{ min.}$$

For a bidirectional carousel, the retrieval of 20 parts would require

$$20Tr = 20 \times (0.25 \times (104.57/75) + 0.333)$$

$$Tr = 13.63 \text{ min}$$

The spacing between carriers along the carousel is given by

$$Sc = 104.57/50 = 2.091 \text{ m.}$$

The dual command cycle, the transaction time is given by,

$$Tdc = T (4/3 + 0.5 Q^2 - Q^3/30) + 4 Tpd$$

$$= 0.75 (4/3 + 0.5 (0.889)^2 - (0.889)^3/30) + 4 (30/60)$$

$$= 3.278 \text{ minutes.}$$

UNIT-V

PREVENTIVE MAINTAINANCE

Maintenance Definition:

“Maintenance is a routine and recurring activity of keeping a particular machine or facility at its normal operating condition so that it can deliver its expected performance or service without causing any loose of time on account of accidental damage or breakdown”

Objectives of maintenance :

The objectives of maintenance should be formulated within the framework of the overall organizational setup so that finally the goals of the organization are accomplished.

For this, the maintenance division needs to ensure that:

- (a) The machinery and/or facilities are always in an optimum working condition at the lowest possible cost
- (b) The time schedule of delivering to the customers is not affected because of non -availability of machinery /service in working condition
- (c) The performance of the machinery /facility is dependable and reliable.
- (d) The performance of the machinery /facility is kept to minimum to the event of the breakdown.
- (e) The maintenance cost is properly monitored to control overhead costs.
- (f) The life of equipment is prolonged while maintaining the acceptable level of performance to avoid unnecessary replacements.

Effects of maintenance

- Maintenance, being an important function in any production system, has far reaching effects on the system.
- If the right practice of maintenance is not established for a particular environment, it may lead to serious problem of either over maintenance or under maintenance.
- The selection of a particular maintenance policy is also governed by the past history of the equipment.
- Cost effective maintenance will help in enhancing productivity. It is therefore, is important for the team associated with maintenance work, to know how much to maintain.
- The nature of the maintenance function affects the life of equipment.

- It is known from experience that optimum maintenance will prolong the life of the equipment, and on the other hand, carelessness in maintenance would lead to reduced life of the equipment and in some cases an early failure as well.
- Further, proper maintenance will help to achieve the production targets. If the availability of the equipment in good working condition is high, the reliability of the production will also be high.
- Another important effect of the maintenance function is the working environment. If the equipment is in good working condition, the operator feels comfortable to use it otherwise there is a tendency to let the equipment deteriorate further.
- To get the desired results in maintenance operations, there should be selective development of skilled, semiskilled, and unskilled labour.

Preventive Maintenance:

- “The maintenance carried at predetermined intervals or corresponding to prescribed criteria and intended to reduce the probability of failure or the performance degradation of an item.”
- Preventive maintenance attempts to prevent any probable failures/breakdowns resulting in production stoppages. It is said that Preventive maintenance is a stitch in time that saves time. So it follows a slogan that “prevention is better than cure”.
- Preventive maintenance refers to maintenance action performed to keep or retain a machine/equipment or asset in a satisfactory operating condition through periodic inspections, lubrication, calibration, replacements and overhauls.

Preventive Maintenance Involves:

- (i) Periodic inspection of equipment/machinery to uncover condition that lead to production breakdown and harmful depreciation. Upkeeps of plant machinery to correct such conditions while they are still in a minor stage.
- (ii) The key to all good preventive maintenance programs, however is inspection.
- (iii) Regular cleaning, greasing and oiling of moving parts.
- iv) Replacement of worn out parts before they fail to operate,
- (v) Periodic overhauling of the entire machine.
- (vi) Machines or equipment's which are liable to sudden failures should be installed in duplicate e.g. motors, pumps, transformers and compressors etc.

Features of Preventive Maintenance:

A well-conceived preventive maintenance programme should possess the following features:

- (1) Proper identification of all items to be included in the maintenance programme.
- (2) Adequate records covering, volume of work, associated costs etc.
- (3) Inspection with a definite schedule with standing order on specific assignments.
- (4) Use of checklists by inspectors.
- 5) An inspection frequency schedule
- (6) A crew of well qualified inspectors with competency of simple repairs, as and when small trouble is noticed.
- (7) Administrative procedures which provide necessary fulfilment as well as follow up on programmes.

Objectives of Preventive Maintenance

Objectives of Preventive Maintenance:

- (1) To minimize the possibility of unanticipated production interruption or major breakdown by uncovering any condition which may lead to it.
- (2) To make plant, equipment and machinery always available and ready for use.
- (3) To maintain the value of equipment and machinery by periodic inspections, repairs, overhauls etc.
- (4) To reduce the work content of maintenance jobs.
- (5) To maintain the optimum productive efficiency of the plant equipment and machinery.
- (6) To maintain the operational accuracy of the plant equipment.
- (7) To achieve maximum production at minimum repair cost.
- (8) To ensure safety of life and limbs of the workmen along with plant equipment and machines etc.
- (9) To maintain the operational ability of the plant as a whole.

Procedure of Preventive Maintenance:

There is no readymade, on the shelf, preventive maintenance procedure for any industry or enterprise involved in manufacturing activities. In view of the fact that all industries differ in size, location, layout, construction, resources, machinery and its age so as to suit the requirements of an individual industrial plant, the preventive maintenance programs are specifically framed.

A well-conceived preventive maintenance programme has the following elements, features or steps to be adhered to in general:

- (1) Who should perform preventive maintenance?
- (2) Where to start preventive maintenance?
- (3) What to inspect regarding preventive maintenance?
- (4) What to Inspect for?

Procedure of Preventive Maintenance:

- 5) What should be the frequency of Inspection?
- (6) When to inspect or inspection schedules?
- (7) What are preventive maintenance stages?
- (8) Training of Maintenance staff.
- (9) Motivation Techniques.
- (10) Maintenance of Records of Preventive Maintenance.
- (11) Material Management for Maintenance.
- (12) Control and Evaluation of Preventive maintenance.

In view of the elements of PM mentioned above for establishing a sound preventive maintenance system in a manufacturing enterprise, we require extra manpower, maintenance facilities, testing equipment's and spare parts etc.

- To start with but in the long run it provides a lot of benefits by way of reduction in production losses, down time and repair costs etc.

Thus the essential requirements for a sound preventive maintenance can be listed as follows:

(1) Proper identification of machines/equipment's and tools:

Every item must be uniquely identified by a prominent serial/identity number.

(2) Adequate past records must be available for all equipment's being utilized. It should furnish complete details regarding previous maintenance operations/activities.

(3) Breakdown/Failures Data:

Sufficient breakdown information regarding criticality and frequency of failures must be available for all machines. This would be needed for the purpose of failure identification, failure diagnostics, analysis as well as final rectification.

(4) Secondary data:

In fact it is a sort of experienced data for similar equipment being utilized.

(5) Manufacturer's utilization recommendations:

Regarding the use of a particular machine i.e. how to utilize and provide P.M.

(6) Service manuals, instruction and maintenance sheets.

(7) Consumables and replacable parts/components should be available as and when needed.

(8) Availability of requisite skilled manpower may be engineers, inspectors and technicians.

(9) Availability/provision of test rigs/equipment's i.e., test rigs, sensors etc.

(10) Clear instructions with a check list regarding preventive and corrective measures must be available to ensure proper functioning of the system.

(11) Users feedback and cooperation:

The user of the equipment/machine must provide feedback to the manufacturer regarding actual functioning of the equipment.

(12) Management Support:

For establishing a preventive maintenance system, the commitment of top management is very essential for the implementation of preventive maintenance policy of the organization.

Applications of Preventive Maintenance

Applications of Preventive Maintenance:

- (1) This system of maintenance is applicable for automated or continuous production process e.g., steel mills, chemical plants and automobile industries.
- (2) In some of the abovementioned practical situations the cost of lost production due to a failure/breakdown can be extremely high. Besides, such heavy cost of failures, the breakdowns may be totally destructive in nature i.e., the failure of a small equipment may lead to complete breakdown of the system. Hence preventive maintenance system is essential in such situations to ensure continuous and failure free plant operation.
- (3) In the failure of equipment's such as boilers, turbines, pressure vessels and lifting devices the results may be fatal sometimes. Thus in order to avoid any loss of human life and health hazards, a proper preventive maintenance system must be adopted.

Examples of preventive maintenance

Examples where preventive maintenance is adopted are as follows:

- (i) P.M. of machine tools.
- (ii) P.M. of pressure vessels or boilers.
- (iii) P.M. of steam and gas turbines.
- (iv) P.M. of heat exchangers,
- (v) P.M. of mobile compressors and generators.
- (vi) Overhead cranes.
- (vii) Small power plants.
- (viii) Elevators.
- (ix) Vehicles.

Preventive maintenance is subdivided into following two categories:

- (i) Running.
- (ii) Shut down.

Running maintenance means that maintenance work carried out even when machine or equipment is in service, while shut down maintenance is concerned with maintenance work carried out only when the machine/equipment is not in operation.

Advantages of Preventive Maintenance:

Advantages of Preventive Maintenance:

- (1) Reduction in breakdown time and associated breakdown elements.
- (2) Reduces the odd time repairs and over time to the maintenance staff.
- (3) Fewer large scale and repetitive repairs.
- (4) Less member of standby equipment ad spare parts required.
- (5) Greater safety to work force/employees due to reduced breakdowns.
- (6) Increased life of equipment and machines.
- (7) The work load of the maintenance staff can be properly planned.
- (8) It improves the availability of facilities.
- (9) Optimum production efficiency can be achieved by employing preventive maintenance.
- (10) Maintenance and repair cost reduce heavily.

- 11) It improves the quality of product and reduces rejections.
- (12) Production cost goes down by adopting RM.
- (13) Regular planned servicing and adjustment maintains and provides a high level of plant output, better equipment performance and better product quality.
- (14) Healthy, hygienic, safe and an accident free work environment can be achieved with the application of scientific preventive maintenance. This would promote industrial relations since workers do not lose any type of incentive due to breakdowns or accidents.
- (15) Reduction in inventory

Limitations of Preventive Maintenance:

Limitations of Preventive Maintenance:

- (1) When the cost of failure prevention is always greater than cost of failure rectification the process of P.M is very costly e.g., batch production-bridge construction.
- (2) The type of maintenance requires extra facilities and lead to under/poor utilization of basic facilities for RM.
- (3) For small scale manufacturing units which are mainly undertaking job and batch production, the P.M system is not suited and economically justified.

KANBAN:

- Kanban (Kahn Bahn) is Japanese word that when translated literally means “visible record” or “visible part”.
- In general context, it refers to a signal of some kind. Thus, in the manufacturing environment, kanbans are signals used to replenish the inventory of items used repetitively within a facility.
- The kanban system is based on a customer of a part pulling the part from the supplier of that part.
- The customer of the part can be an actual consumer of a finished product (external) or the production personnel at the succeeding station in a manufacturing facility (internal).
- Likewise, the supplier could be the person at the preceding station in a manufacturing facility.
- The premise of kanbans is that material will not be produced or moved until a customer sends the signal to do so.

- The typical kanban signal is an empty container designed to hold a standard quantity of material or parts.
- When the container is empty, the customer sends it back to the supplier.
- The container has attached to it instructions for refilling the container such as the part number, description, quantity, customer, supplier, and purchase or work order number.
- Some other common forms of kanban signals are supplier replaceable cards for cardboard boxes designed to hold a standard quantity, standard container enclosed by a painting of the outline of the container on the floor, and color coded striped golf balls sent via pneumatic tubes from station to station.

Kanbans serve many purposes:

- They act as communication devices from the point of use to the previous operation and as visual communication tools.
- They act as purchase orders for your suppliers and work orders for the production departments, thereby eliminating much of the paperwork that would otherwise be required.
- In addition, kanbans reinforce other manufacturing objectives such as increasing responsibility of the machine operator and allowing for proactive action on quality defects.
- However, kanbans should not be used when lot production or safety stock is required because the kanban system will not account for these requirements.

TYPES OF KANBAN

Dual-Card Kanban

- This kanban system is more commonly referred to as the Toyota kanban system as Toyota was the first to employ this system in full-scale use.
- It is a more useful kanban technique in large-scale, high variety manufacturing facilities. In this system, each part has its own special container designed to hold a precise quantity of that part.
- Two cards are used: the production kanban, which serves the supplier workstation and the conveyance kanban, which serves the customer workstation. Each container cycles from the supplier workstation to its stock point to the customer workstation and its stock point, and back while one kanban is exchanged for another. No parts are produced unless a P-kanban authorizes it.
- There is only one C-kanban and one P-kanban for each container and each container holds a standard quantity (no more, no less).

Figure 3.1 clearly explains this process using the Milling (supplier) and Drilling (customer) processes.

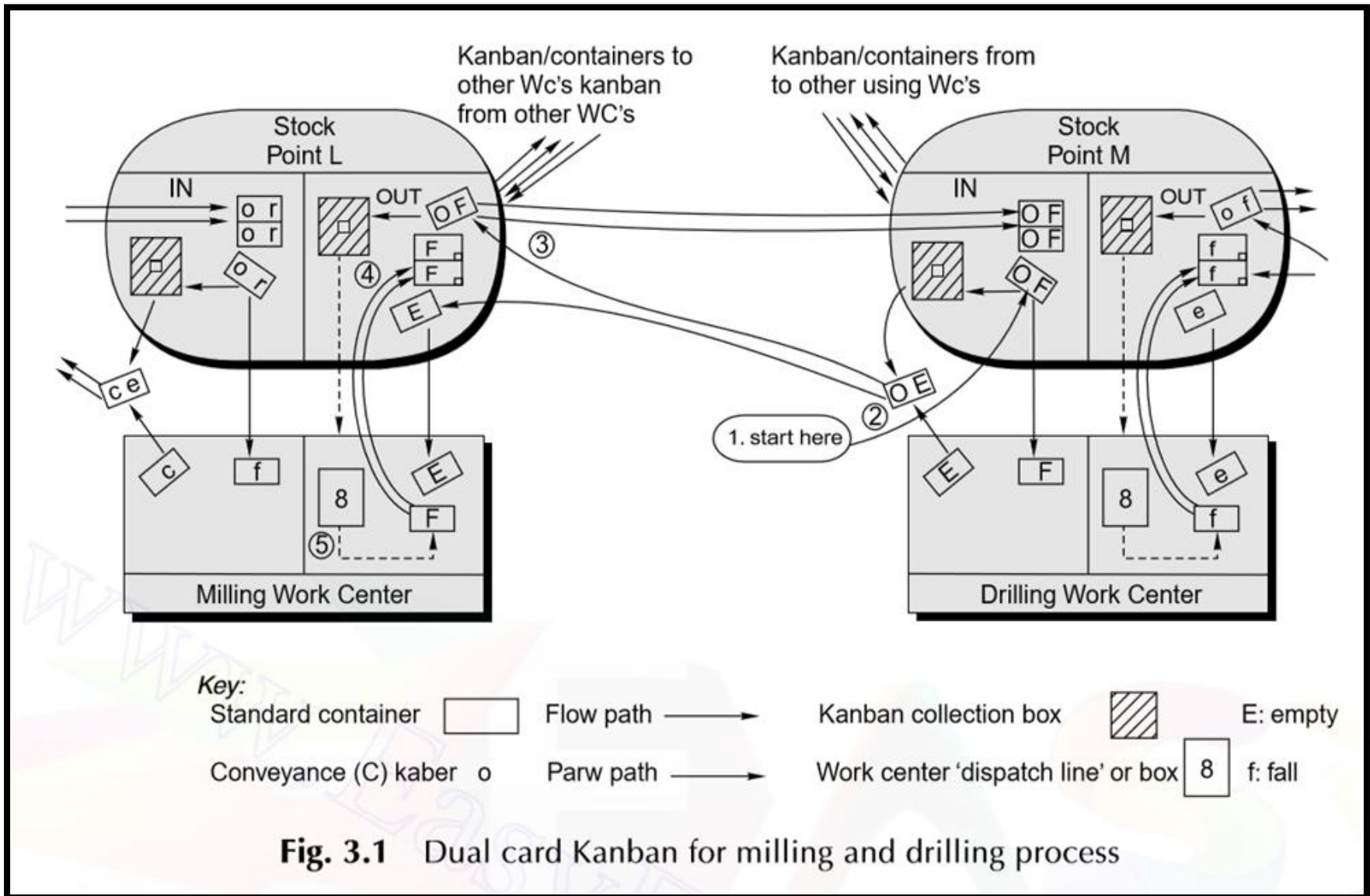

PROCESS

1. Find the note “Start here”. The C-kanban is detached and placed in a collection box for Stock Point M.
2. The container that is most recently emptied in Drilling is taken to Stock Point M and a Ckanban is attached to it.
3. The empty container and C-kanban are taken to Stock Point L where the C-kanban is detached and re-attached to a full container, which is taken back to Stock Point M.
4. The full container taken to Stock Point M had a P-kanban attached to it. Before leaving Stock Point L, the P-kanban was detached and placed in the Stock Point L collection box.
5. The P-kanban in the Stock Point L collection box are taken to Milling hourly where they go into a dispatch box and become the list of jobs to be worked on next at the Milling Station.
6. For every job that is completed, parts go into an empty container from Stock Point L, and a P-kanban is attached. The full container is then moved back to Stock Point L.

Single-Card Kanban

Single-Card Kanban

- The single-card kanban system is a more convenient system for manufacturing facilities requiring less variety in their parts. Essentially, the single-card kanban system is simply a dual-card kanban system with the absence of the production kanban and designated stock points.
- This system is demonstrated using the following diagram and the same workstations as the dual-card example (where the stock points shown are the work stations themselves but are shown separately for explanation purposes):

1. Find the note “Start here”. A container has just been emptied at the drilling station. The kanban is placed in the kanban collection box
2. The full containers at milling, with kanbans attached to them, are transported to drilling and the kanbans in the collection box are taken back to milling.
3. Milling continues to fill containers depending on the demand from Drilling.
4. Empty containers are collected from drilling periodically.

Due to the inherent simplicity of the single-card kanban system and its applicability to the purposes of this report, the remainder of the report shall assume this technique is employed

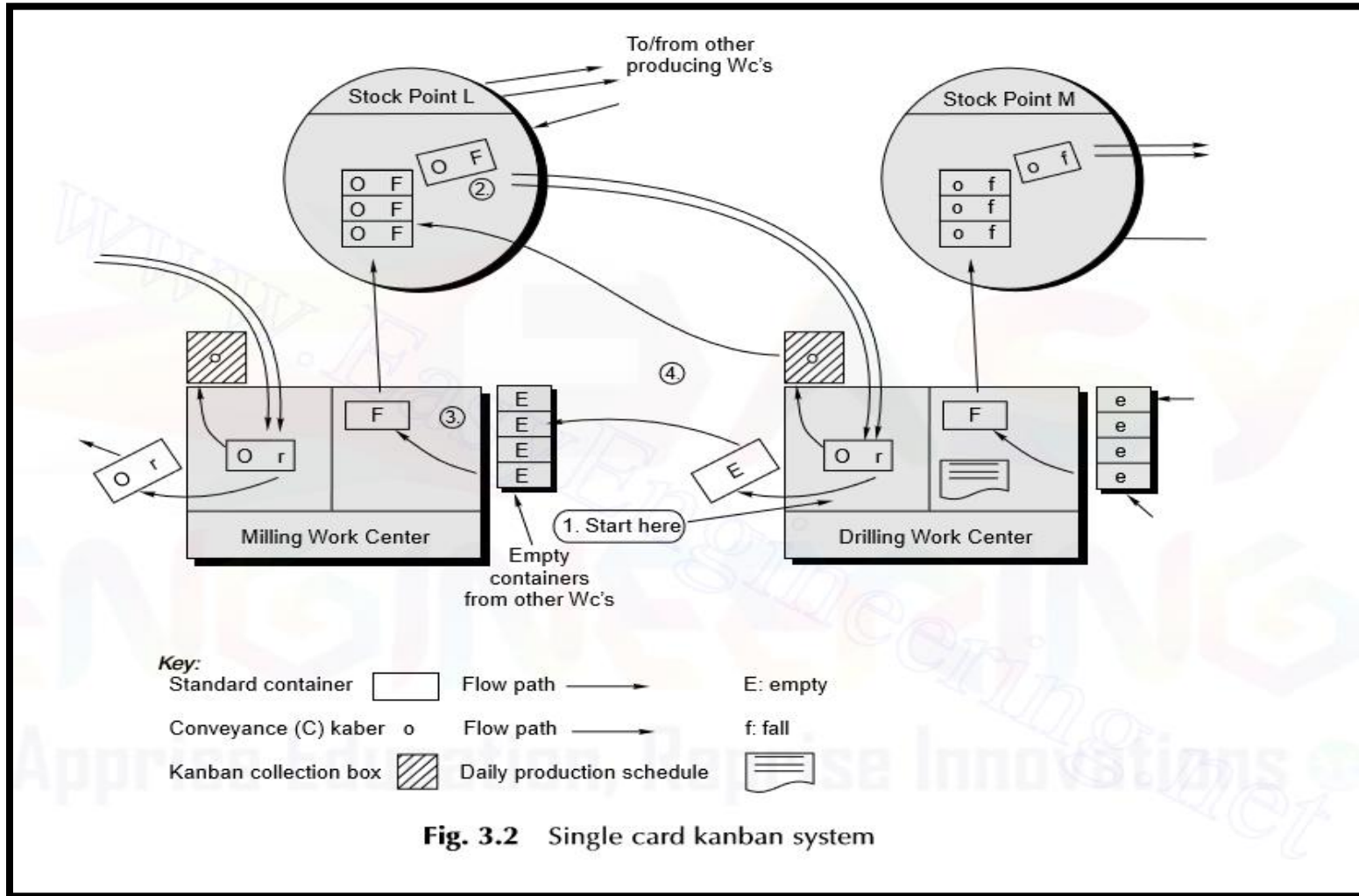

Kanban Method

Kanban Method

At the beginning of the 21st Century, key players within the software industry quickly realized how Kanban could be used to positively change the ways in which products and services were delivered.

With an increased focus on efficiency, and by harnessing advances in computing technology, Kanban left the realm of the automotive industry and was successfully applied to other complex commercial sectors such as IT, software development, marketing and so on.

Indeed, what we now recognize as the Kanban Method with all core elements emerged at the beginning of 2007.

The simplest [Kanban board](#) may start with three columns – “Requested”, “In Progress” and “Done”. When constructed, managed and functioning properly, it serves as a real-time information repository, highlighting bottlenecks within the system and anything else which might get in the way of smooth working practices.

Principles of Kanban

The 4 Core Principles of Kanban

David J. Anderson (a pioneer in the field of Lean/ Kanban for knowledge work) has formulated the Kanban method as an approach to incremental, evolutionary process and systems change for knowledge work organizations. It is focused on getting things done and the most important principles can be broken down into four basic principles and six practices.

Principle 1: Start With What You Do Now

Kanban's flexibility allows it to be overlaid on existing workflows, systems and processes without disrupting what is already successfully being done; it will, naturally, highlight issues that need to be addressed and help to assess and plan changes so their implementation is as non-disruptive as possible.

Kanban's versatility allows it to be introduced incrementally, and sympathetically, to all types of organization without fear of over-commitment or 'culture shock'. This makes Kanban easy to implement in any type of organization as there is no need for you to make sweeping changes right from the start.

Principle 2: Agree to Pursue Incremental, Evolutionary Change

The Kanban methodology is designed to meet minimal resistance and thus encourages continuous small incremental and evolutionary changes to the current process. In general, sweeping changes are discouraged because they usually encounter resistance due to fear or uncertainty.

Principle 3: Respect the Current Process, Roles & Responsibilities

Kanban recognizes that existing processes, roles, responsibilities, and titles have value and are, generally, worth preserving. The Kanban method does not prohibit change, but neither does it prescribe it as a 'universal panacea'. It is designed to promote and encourage incremental, logical, changes without triggering a fear of change itself.

Principle 4: Encourage Acts of Leadership at All Levels

This is the newest Kanban principle. It reminds you that some of the best leadership comes from everyday acts of people on the front line of their teams. It is important that everyone fosters a mindset of continuous improvement (Kaizen) in order to reach optimal performance on a team/department/company level. This can't be a management level activity.

6 Practices of Kanban

The 6 Practices of Kanban

Although embracing the Kanban philosophy and embarking on the transitional journey is the most important step, every organization needs to be careful with the practical steps. There are six core practices as identified by David Anderson that need to be present for successful implementation.

1. Visualize the Workflow
2. Limit Work in Progress
3. Manage Flow
4. Make Process Policies Explicit
5. Feedback Loops
6. Improve Collaboratively (using models & the scientific method)



6 REASONS YOU MAY FAIL WITH KANBAN IMPLEMENTATION

- ❖ Implementing Kanban in your organization may seem easy, but it is a bit tricky indeed. If you start without the necessary respect for details things can go wrong.
- ❖ Imagine that you have the fastest car in Formula 1. However, you decide to put one of your engineers behind the wheel and tell him to win the race. What are the odds? After all, he will drive the best racing car. Nevertheless, we all know that chances for a triumph are close to zero.
- ❖ It is the same with Kanban implementation. If you just say to your team “Kanban is the best method for workflow management, make it work for you”, your staff will probably feel like an experienced F1 engineer with a great car that he doesn’t know how to drive.
- ❖ So instead of creating uncertainty, make sure your team is familiar with how to use Kanban properly.
- ❖ Let’s dig a bit deeper and reveal some of the main reasons that may fail you in implementing Kanban in your work process.

6 REASON FOR WHY YOU FAIL TO IMPLEMENTATION OF KANBAN

REASON FOR WHY YOU FAIL TO IMPLEMENTATION OF KANBAN

1. Nobody Explained What Kanban Actually Is About
 2. Replacing the Whole Process or When Not to Use Kanban
 3. Nobody Respects the WIP Limits
 4. You Create a Parallel Universe on the Kanban Board
 5. You Don't Use the Full Capacity of Kanban
- You Want to Squeeze All the Juice Out of Kanban Right Now

Thank you!