



**INSTITUTE OF AERONAUTICAL ENGINEERING**  
**(Autonomous)**  
Dundigal, Hyderabad -500 043  
**MECHANICAL ENGINEERING**

**COURSE LECTURE NOTES**

<b>Course Name</b>	<b>MACHINE DESIGN</b>
<b>Course Code</b>	AME015
<b>Programme</b>	B.Tech
<b>Semester</b>	VI
<b>Course Coordinator</b>	Dr. G.V.R.Seshagiri Rao, Professor
<b>Course Faculty</b>	Dr.B.Vijay krishna , Assistant Professor
<b>Lecture Numbers</b>	1-55
<b>Topic Covered</b>	All

**COURSE OBJECTIVES (COs):**

<b>The course should enable the students to:</b>	
I	Ability to identify design variables and performance factors in the study of journal bearings.
II	Ability to identify different types of rolling contact bearings, their basic features, related terminology and designations
III	Ability to select rolling contact bearings for a given application
IV	Awareness of the basic features of prime movers and the means of power transmission commonly used in mechanical engineering
V	Ability to analyze and design all types of gears for given application

**COURSE LEARNING OUTCOMES (CLOs):**

**Students, who complete the course, will have demonstrated the ability to do the following:**

<b>S.No</b>	<b>Description</b>
AME012.01	Explain various lubrication process, Illustrate various parts of bearing
AME012.02	Analyze heat dissipation in bearings
AME012.03	Select the lubricants for various applications
AME012.04	Discuss types of bearings for required application
AME012.05	Describe static and dynamic rating of roller bearings
AME012.06	Explain various parts of connecting Rod
AME012.07	Illustrate about thrust acting on a connecting Rod
AME012.08	Categorize & Describe about stresses induced and find suitable cross section
AME012.09	Classify the various types of Crankshafts.
AME012.10	Calculate the sizes of different parts of crankshaft and crank pin

AME012.11	Explain the various parts of the piston and forces acting on each of these parts
AME012.12	Construct the piston diagram and generate formulae
AME012.13	Describe the various types of belt drives and transmission power and V.R
AME012.14	Describe the construction of ropes
AME012.15	Define the efficiency of power transmission and explain factors effecting efficiency
AME012.16	Distinguish different pulleys for belt and rope drives
AME012.17	Describe load transmission between gear teeth and Illustrate dynamic load factors
AME012.18	Compare the equations for compressive and bending strength
AME012.19	Explain the Procedure design of spur gears
AME012.20	Describe the governing equation and find the dynamic and wear strength
AME012.21	Explain Procedure for design of helical and bevel gears
AME012.22	Describe the terminology of power screws
AME012.23	Describe construction and explain failure mechanism
AME012.24	Design of Differential screw
AME012.25	Ball screw-possible failures

## SYLLABUS

<b>UNIT-I</b>	<b>BEARINGS</b>
Bearings: Types of journal bearings, basic modes of lubrication, bearing modulus, full and partial bearings, Clearance ratio, Heat dissipation of bearings, bearing materials, Journal bearing design. Ball and roller bearing, Static load-dynamic load, equivalent radial load-design and selection of ball and roller bearings.	
<b>UNIT-II</b>	<b>DESIGN OF IC ENGINE PARTS</b>
Connecting rod: thrust in connecting rod-stress due to whipping action on connecting rod ends-cranks and crank shafts, strength and proportions of over hung and center cranks-crank pins, crank shafts, piston, forces acting on piston-construction design and proportions of piston.	
<b>UNIT-III</b>	<b>POWER TRANSMISSION SYSTEMS, PULLEYS</b>
Transmission of power by belt and rope drives, transmission efficiencies, Belts-Flat and V belts-ropes-pulleys for belt and rope drives, materials- chain drives.	
<b>UNIT-IV</b>	<b>SPUR GEAR</b>
Load concentration factor-dynamic load factor, surface compressive strength-bending strength-design analysis of spur gear, check for plastic deformation, check for dynamic and wear considerations. Helical and Bevel Gear Drives: Load concentration factor-dynamic load factor, Analysis of helical and bevel gears, check for plastic deformation, check for dynamic and wear considerations. Design of Worm gears: worm gear-properties of worm gears-selections of materials-strength and wear rating of worm gears-force analysis-friction in worm gears-thermal considerations	
<b>UNIT-V</b>	<b>DESIGN OF POWER SCREWS</b>
Design of screw, design of nut, compound screw, differential screw, ball screw-possible failures	
<b>Text Books:</b>	
1. P. Kanniah, (2012), Machine Design, 2 <sup>nd</sup> Edition, Scitech Publications India Pvt. Ltd, New Delhi, India. 2. V. Bandari (2011), A Text Book of Design of Machine Elements, 3 <sup>rd</sup> edition, Tata McGraw hill education (P) ltd, New Delhi, India.	
<b>Reference Books:</b>	

1. Shigley, J.E, (2011), Mechanical Engineering Design, 9<sup>th</sup> Edition, Tata McGraw-Hill, New Delhi, India.
2. S. M.D. Jalaludin, (2011), Machine Design, 3<sup>rd</sup> Edition, Anuradha Publishers, Kumbakonam, Chennai, India.
3. R. L. Norton (2006), Machine Design (An Integrated approach), 2<sup>nd</sup> edition, Pearson Publishers, Chennai, India.
4. R.S. Khurmi, A. K. Gupta, "Machine Design", S. Chand & Co, New Delhi, 1<sup>st</sup> Edition, 2014.
5. PSG College, "Design Data: Data Book of Engineers", 1<sup>st</sup> Edition, 2012.

## UNIT 1

### JOURNAL BEARINGS

#### 1.1 WHY TO STUDY FRICTION, WEAR & LUBRICATION?

Moving parts of every machine is subjected to friction and wear. Friction consumes and wastes energy. Wear causes changes in dimensions and eventual breakdown of the machine element and the entire machine. The loss of just a few milligrams of material in the right place, due to wear can cause a production machine or an automobile to be ready for replacement. If we imagine the amount of material rendered useless by way of wear, it is startling! Lots of materials ranging from Antimony to zinc, including titanium, vanadium, iron, carbon, copper, aluminum etc., would be lost. It is therefore essential to conserve the natural resources through reduction in wear. Lubrication plays a vital role in our great and complex civilization.

#### 1.2 BEARINGS

A bearing is machine part, which support a moving element and confines its motion. The supporting member is usually designated as bearing and the supporting member may be journal. Since there is a relative motion between the bearing and the moving element, a certain amount of power must be absorbed in overcoming friction, and if the surface actually touches, there will be a rapid wear.

**1.2.1 Classification:** Bearings are classified as follows:

**1. Depending upon the nature of contact between the working surfaces:-**

- a) Sliding contact bearings
- b) Rolling contact bearings.

**a) SLIDING BEARINGS:**

- Hydrodynamically lubricated bearings
- Bearings with boundary lubrication
- Bearings with Extreme boundary lubrication.
- Bearings with Hydrostatic lubrication.

## b) ROLLING ELEMENT BEARINGS:

- Ball bearings
- Roller bearings
- Needle roller bearings

### 1. Based on the nature of the load supported:

- Radial bearings - Journal bearings
- Thrust bearings
  - Plane thrust bearings
  - Thrust bearings with fixed shoes
  - Thrust bearings with Pivoted shoes
- Bearings for combined Axial and Radial loads.

## JOURNAL BEARING:

It is one, which forms the sleeve around the shaft and supports a bearing at right angles to the axis of the bearing. The portion of the shaft resting on the sleeve is called the journal.

**Example of journal bearings are-** Solid bearing, bushed bearing and Pedestal bearing.

### Solid bearing:

A cylindrical hole formed in a cast iron machine member to receive the shaft which makes a running fit is the simplest type of solid journal bearing. Its rectangular base plate has two holes drilled in it for bolting down the bearing in its position as shown in the figure 1.1. An oil hole is provided at the top to lubricate the bearing. There is no means of adjustment for wear and the shaft must be introduced into the bearing endwise. It is therefore used for shafts, which carry light loads and rotate at moderate speeds.

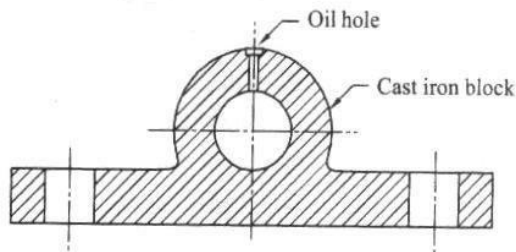

Fig. 7.1 Solid bearing

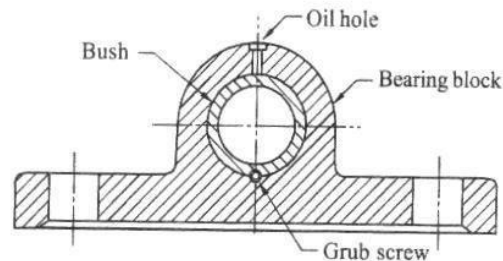

Fig. 7.2 Bushed bearing

### Bushed bearing:

It consists of mainly two parts, the cast iron block and bush; the bush is made of soft material such as brass, bronze or gunmetal. The bush is pressed inside the bore in the cast iron block and is prevented from rotating or sliding by means of grub-screw as shown if the figure 1.2. When the bush gets worn out it can be easily replaced. Elongated holes in the base are provided for lateral adjustment.

### Pedestal bearing:

It is also called Plummer block. Figure 1.3 shows half sectional front view of the Plummer block. It consists of cast iron pedestal, phosphor bronze bushes or steps made in two

halves and cast iron cap. A cap by means of two square headed bolts holds the halves of the steps together. The steps are provided with collars on either side in order to prevent its axial movement. The snug in the bottom step, which fits into the corresponding hole in the body, prevents the rotation of the steps along with the shaft. This type of bearing can be placed anywhere along the shaft length.

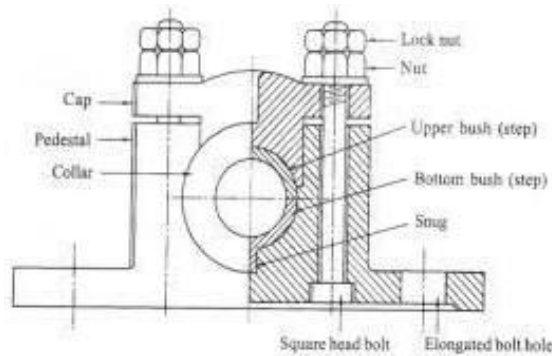

Fig 1.3: Pedestal Bearing

**Thrust bearing:**

It is used to guide or support the shaft, which is subjected to a load along the axis of the shaft. Since a thrust bearing operates without a clearance between the conjugate parts, an adequate supply of oil to the rubbing surfaces is extremely important. Bearings designed to carry heavy thrust loads may be broadly classified in to two groups-

**FOOT STEP BEARING, AND COLLAR BEARING**

**Footstep bearing:** Footstep bearings are used to support the lower end of the vertical shafts. A simple form of such bearing is shown in fig 1.4. It consists of cast iron block into which a gunmetal bush is fitted. The bush is prevented from rotating by the snug provided at its neck. The shaft rests on a concave hardened steel disc. This disc is prevented from rotating along with the shaft by means of pin provided at the bottom.

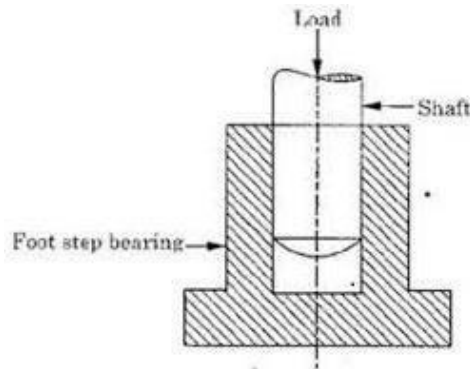

Fig: 1.4 Foot step Bearing

### Collar bearing:

The simple type of thrust bearing for horizontal shafts consists of one or more collars cut integral with the shaft as shown in fig.1.5. These collars engage with corresponding bearing surfaces in the thrust block. This type of bearing is used if the load would be too great for a step bearing, or if a thrust must be taken at some distance from the end of the shaft. Such bearings may be oiled by reservoirs at the top of the bearings.

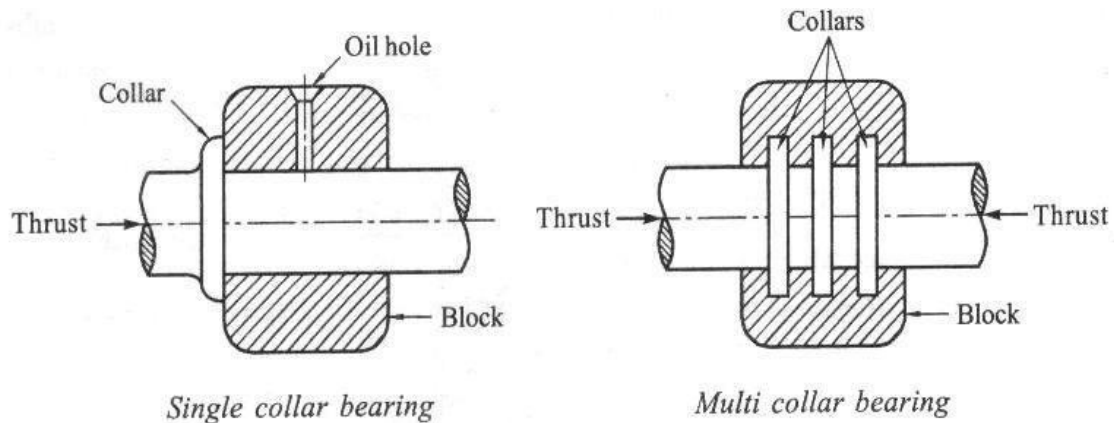

Fig.1.5 Collar bearings

Thrust bearings of fixed inclination pad and pivoted pad variety are shown in figure 1.6 a & b. These are used for carrying axial loads as shown in the diagram. These bearings operate on hydrodynamic principle.

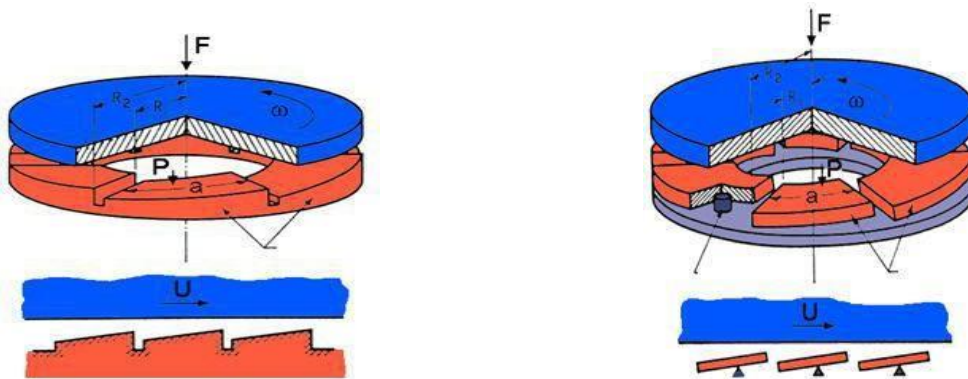

Fig.1.6a Fixed-incline-pads thrust bearing

Fig.1.6b Pivoted-pads thrust bearing

### Rolling contact bearings:

The bearings in which the rolling elements are included are referred to as rolling contact bearings. Since the rolling friction is very less compared to the sliding friction, such bearings are known as anti-friction bearings.

**Ball bearings:**

It consists of an inner ring which is mounted on the shaft and an outer ring which is carried by the housing. The inner ring is grooved on the outer surface called inner race and the outer ring is grooved on its inner surface called outer race. In between the inner and outer race there are number of steel balls. A cage pressed steel completes the assembly and provides the means of equally spacing and holding the balls in place as shown in the figure 1.7. Radial ball bearings are used to carry mainly radial loads, but they can also carry axial loads.

**Cylindrical roller bearings**

The simplest form of a cylindrical roller bearing is shown in fig 1.8. It consists of an inner race, an outer race, and set of roller with a retainer. Due to the line contact between the roller and the raceways, the roller bearing can carry heavy radial loads.

**Tapered roller bearings:**

In tapered roller bearings shown in the fig. 1.9, the rollers and the races are all truncated cones having a common apex on the shaft center to assure true rolling contact. The tapered roller bearing can carry heavy radial and axial loads. Such bearings are mounted in pairs so that the two bearings are opposing each other's thrust.

**1.2.2 ADVANTAGES OF SLIDING CONTACT BEARINGS:**

- They can be operated at high speeds.
- They can carry heavy radial loads.
- They have the ability to withstand shock and vibration loads.
- Noiseless operation.

**Disadvantages:**

- High friction losses during starting.
- More length of the bearing.
- Excessive consumption of the lubricant and high maintenance.

**1.2.3 ADVANTAGES ROLLING CONTACT BEARINGS:**

- Low starting and less running friction.
- It can carry both radial as well as thrust loads.
- Momentary over loads can be carried without failure.
- Shaft alignment is more accurate than in the sliding bearings.

**Disadvantages**

- More noisy at high speeds.
- Low resistance to shock loads.
- High initial cost.
- Finite life due to eventual failure by fatigue

### 1.3 SOLID FRICTION

1. Resistance force for sliding
  - Static coefficient of friction
  - Kinetic coefficient of friction
2. Causes
  - Surface roughness (asperities)
  - Adhesion (bonding between dissimilar materials)
3. Factors influencing friction
  - Sliding friction depends on the normal force and frictional coefficient, independent of the sliding speed and contact area
4. Effect of Friction
  - Frictional heat (burns out the bearings)
  - Wear (loss of material due to cutting action of opposing motion)
5. Engineers control friction
  - Increase friction when needed (using rougher surfaces)
  - Reduce friction when not needed (lubrication)

The coefficients of friction for different material combinations under different conditions are given in table 1.1.

**TABLE 1.1**  
**COEFFICIENTS OF FRICTION**

Material	$\mu$
Perfectly clean metals in vacuum	Seizure $\mu > 5$
Clean metals in air	0.8-2
Clean metals in wet air	0.5-1.5
Steel on dry bearing metals (e.g. lead, bronze)	0.1-0.5
Steel on ceramics	0.1-0.5
Ceramics on ceramics (e.g. carbides on carbides)	0.05-0.5
Polymers on polymers	0.05-1.0
Metals and ceramics on polymers (PE, PTFE, PVC)	0.04-0.5
Boundary lubrication of metals	0.05-0.2
High-temperature lubricants (MoS <sub>2</sub> , graphite)	0.05-0.2
Hydrodynamic lubrication	0.001-0.005



## 1.4 LUBRICATION:

Prevention of metal to metal contact by means of an intervening layer of fluid or fluid like material.

### Types of sliding lubrication:

- Sliding with Fluid film lubrication.
- Sliding with Boundary lubrication.
- Sliding with Extreme boundary lubrication.
- Sliding with clean surfaces.

### 1.4.1 HYDRODYNAMIC / THICK FILM LUBRICATION / FLUID FILM LUBRICATION

Metal to Metal contact is prevented. This is shown in figure 1.10. Friction in the bearing is due to oil film friction only. Viscosity of the lubricant plays a vital role in the power loss, temperature rise & flow through of the lubricant through the bearing. The principle operation is the Hydrodynamic theory. This lubrication can exist under moderately loaded bearings running at sufficiently high speeds.

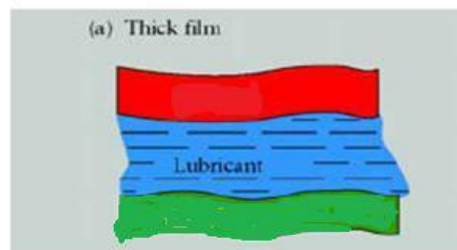

Fig.1.10 Thick Film Lubrication

### 1.4.2 BOUDARY LUBRICATION (THIN FILM LUBRICATION)

During starting and stopping, when the velocity is too low, the oil film is not capable of supporting the load. There will be metal to metal contact at some spots as shown in figure 1.11. Boundary lubrication exists also in a bearing if the load becomes too high or if the viscosity of the lubricant is too low. Mechanical and chemical properties of the bearing surfaces and the lubricants play a vital role.

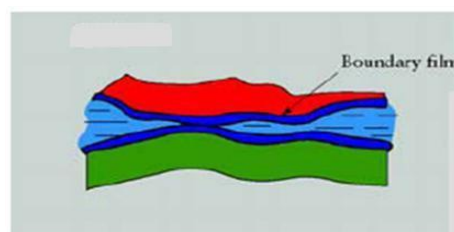

Fig.1.11 Boundary Lubrication

Oiliness of lubricant becomes an important property in boundary lubrication. Anti-oxidants and Anti-corrosives are added to lubricants to improve their performance. Additives are added to improve the viscosity index of the lubricants.

### Oiliness Agents

- Increase the oil film's resistance to rupture, usually made from oils of animals or vegetables.
- The molecules of these oiliness agents have strong affinity for petroleum oil and for metal surfaces that are not easily dislodged.
- Oiliness and lubricity (another term for oiliness), not related to viscosity, manifest itself under boundary lubrication; reduce friction by preventing the oil film breakdown.

### Anti-Wear Agents

Mild EP additives protect against wear under moderate loads for boundary lubrications. Anti-wear agents react chemically with the metal to form a protective coating that reduces friction, also called as anti-scuff additives.

### **1.4.3 Extreme boundary lubrication**

Under certain conditions of temperature and load, the boundary film breaks leading to direct metal to metal contact as shown in figure 1.12. Seizure of the metallic surfaces and destruction of one or both surfaces begins. Strong intermolecular forces at the point of contact results in tearing of metallic particles. "Plowing" of softer surfaces by surface irregularities of the harder surfaces. Bearing material properties become significant. Proper bearing materials should be selected.

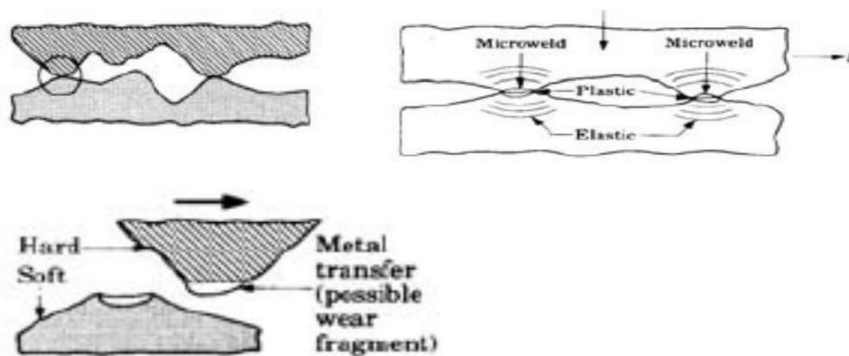

Fig.1.12 Extreme Boundary Lubrication

### **Extreme-Pressure Agents**

Scoring and pitting of metal surfaces might occur as a result of this case, seizure is the primarily concern. Additives are derivatives of Sulphur, phosphorous, or chlorine. These additives prevent the welding of mating surfaces under extreme loads and temperatures.

## **Stick-Slip Lubrication**

A special case of boundary lubrication when a slow or reciprocating action exists. This action is destructive to the full fluid film. Additives are added to prevent this phenomenon causing more drag force when the part is in motion relative to static friction. This prevents jumping ahead phenomenon.

### **1.4.4 Solid film lubrication**

When bearings must be operated at extreme temperatures, a solid film lubricant such as graphite or molybdenum di-sulfide must be used because the ordinary mineral oils are not satisfactory at elevated temperatures. Much research is currently being carried out in an effort to find composite bearing materials with low wear rates as well as small frictional coefficients.

### **1.4.5. Hydrostatic lubrication**

*Hydrostatic lubrication* is obtained by introducing the lubricant, which is sometimes air or water, into the load-bearing area at a pressure high enough to separate the surfaces with a relatively thick film of lubricant. So, unlike hydrodynamic lubrication, this kind of lubrication does not require motion of one surface relative to another. Useful in designing bearings where the velocities are small or zero and where the frictional resistance is to be an absolute minimum.

### **1.4.6 Elasto Hydrodynamic lubrication**

Elasto-hydrodynamic *lubrication* is the phenomenon that occurs when a lubricant is introduced between surfaces that are in rolling contact, such as mating gears or rolling bearings. The mathematical explanation requires the Hertzian theory of contact stress and fluid mechanics.

## **1.5 Newton's Law of Viscous Flow**

In Fig. 1.13 let a plate  $A$  be moving with a velocity  $U$  on a film of lubricant of thickness  $h$ . Imagine the film to be composed of a series of horizontal layers and the force  $F$  causing these layers to deform or slide on one another just like a deck of cards. The layers in contact with the moving plate are assumed to have a velocity  $U$ ; those in contact with the stationary surface are assumed to have a zero velocity. Intermediate layers have velocities that depend upon their distances  $y$  from the stationary surface.

Newton's viscous effect states that the shear stress in the fluid is proportional to the rate of change of velocity with respect to  $y$ .

Thus  $T = F/A = Z (du/dy)$ .

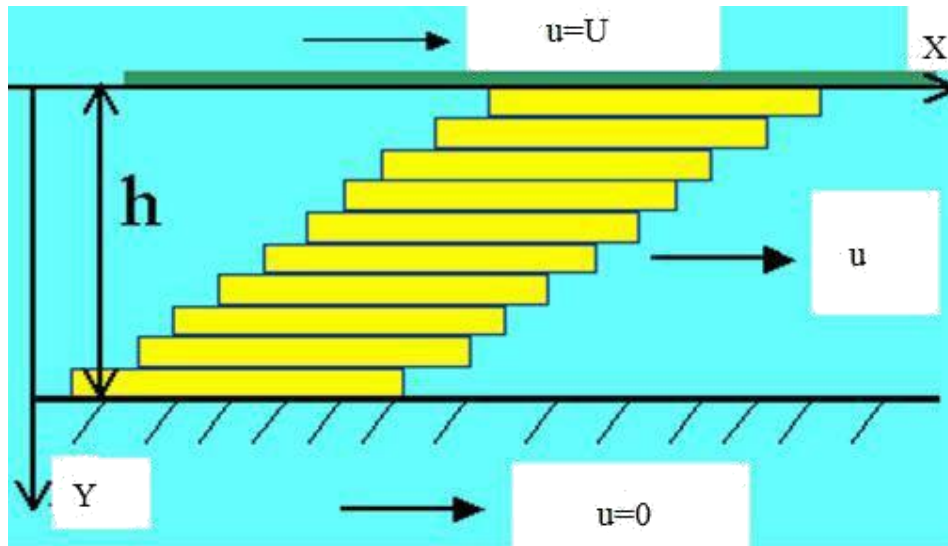

Fig.1.13 Viscous flow

where  $Z$  is the constant of proportionality and defines *absolute viscosity*, also called *dynamic viscosity*. The derivative  $du/dy$  is the rate of change of velocity with distance and may be called the rate of shear, or the velocity gradient. The viscosity  $Z$  is thus a measure of the internal frictional resistance of the fluid.

For most lubricating fluids, the rate of shear is constant, and  $du/dy = U/h$ . Fluids exhibiting this characteristic are known as a Newtonian fluids.

Therefore  $\tau = F/A = Z (U/h)$ .

The absolute viscosity is measured by the pascal-second ( $\text{Pa} \cdot \text{s}$ ) in SI; this is the same as a Newton-second per square meter.

The poise is the CGS unit of dynamic or absolute viscosity, and its unit is the dyne second per square centimeter ( $\text{dyn} \cdot \text{s}/\text{cm}^2$ ). It has been customary to use the centipoises (cP) in analysis, because its value is more convenient. The conversion from CGS units to SI units is as follows:

$$Z (\text{Pa} \cdot \text{s}) = (10)^{-3} Z (\text{cP})$$

Kinematic Viscosity is the ratio of the absolute Viscosity to the density of the lubricant.

$$Z_k = Z / \rho$$

The ASTM standard method for determining viscosity uses an instrument called the Saybolt Universal Viscometer. The method consists of measuring the time in seconds for 60 mL of lubricant at a specified temperature to run through a tube 17.6 micron in diameter and 12.25 mm long. The result is called the *kinematic viscosity*, and in the past

the unit of the square centimeter per second has been used. One square centimeter per second is defined as a **stoke**.

The kinematic viscosity based upon seconds Saybolt, also called *Saybolt Universal viscosity* (SUV) in seconds, is given by:

$$Z_k = (0.22t - 180/t)$$

where  $Z_k$  is in centistokes (cSt) and  $t$  is the number of seconds Saybolt.

### 1.6 Viscosity -Temperature relation

Viscous resistance of lubricating oil is due to intermolecular forces. As the temperature increases, the oil expands and the molecules move further apart decreasing the intermolecular forces. Therefore the viscosity of the lubricating oil decreases with temperature as shown in the figure.1.14. If speed increases, the oil's temperature increases and viscosity drops, thus making it better suited for the new condition. An oil with high viscosity creates higher temperature and this in turn reduces viscosity. This, however, generates an equilibrium condition that is not optimum. Thus, selection of the correct viscosity oil for the bearings is essential.

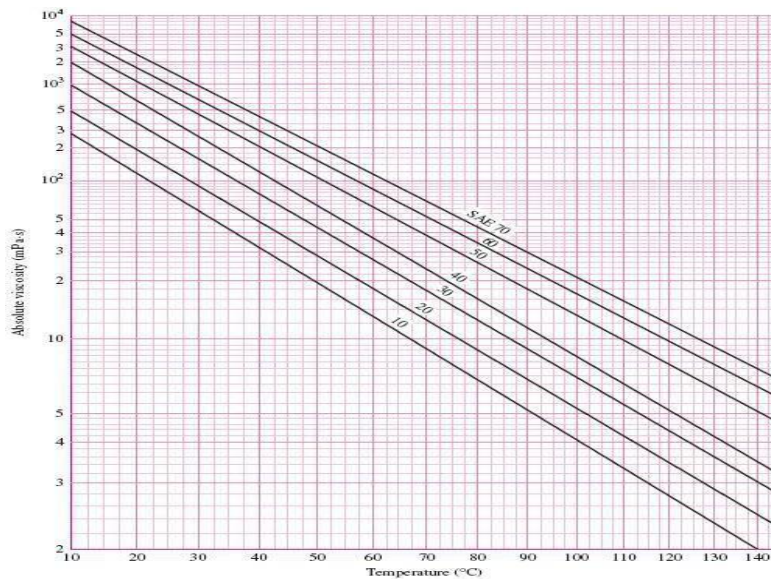

Fig.1.14 Viscosity temperature relationship

### Viscosity index of a lubricating oil

Viscosity Index (V.I) is value representing the degree for which the oil viscosity changes with temperature. If this variation is small with temperature, the oil is said to have a high viscosity index. The oil is compared with two standard oils, one having a V.I. of 100 and the other Zero. A viscosity Index of 90 indicates that the oil with this value thins out less rapidly than an oil with V.I. of 50.

## 1.7 Types of lubricants

- Vegetable or Animal oils like Castor oil, Rapeseed oil, palm oil, Olive oil etc.
- Animal oils like lard oil, tallow oil, whale oil, etc.
- Mineral oils-petroleum based- Paraffinic and Naphthenic based oils

## Properties of lubricants

- Availability in wide range of viscosities.
- High Viscosity index.
- Should be chemically stable with bearing material at all temperatures encountered.
- Oil should have sufficient specific heat to carry away heat without abnormal rise in temperature.
- Reasonable cost.

## Selection Guide for Lubricants

The viscosity of lubricating oil is decisively for the right thickness of the lubricating film (approx. 3-30 $\mu$ m) under consideration of the type of lubricant supply

Low sliding speed	High Viscosity
High sliding speed	Low viscosity
High bearing clearance	High Viscosity
High load (Bearing pressures)	Higher Viscosity

## 1.8 Bearing materials

Relative **softness** (to absorb foreign particles), reasonable strength, **machinability** (to maintain tolerances), **lubricity**, **temperature and corrosion resistance**, and in some cases, **porosity** (to absorb lubricant) are some of the important properties for a bearing material.

A bearing element should be *less than one-third as hard* as the material running against it in order to provide **embedability** of abrasive particles.

A bearing material should have high compression strength to withstand high pressures without distortion and should have good fatigue strength to avoid failure due to pitting. E.g. in Connecting rod bearings, Crank shaft bearings, etc. A bearing material should have conformability. Soft bearing material has *conformability*. Slight misalignments of bearings can be self-correcting if plastic flow occurs easily in the bearing metal. Clearly there is a compromise between load-bearing ability and conformability.

In bearings operating at high temperatures, possibility of oxidation of lubricating oils leading to formation of corrosive acids is there. The bearing material should be **corrosion resistant**. Bearing material should have easy **availability and low cost**. The bearing material

should be soft to allow the dirt particles to get embedded in the bearing lining and avoid further trouble. This property is known as **Embeddability**.

### Different Bearing Materials

- **Babbitt or White metal** -- usually used as a lining of about 0.5mm thick bonded to bronze, steel or cast iron.
  - Lead based & Tin based Babbitt's are available.
  - Excellent conformability and embeddability
  - Good corrosion resistance.
  - Poor fatigue strength
- **Copper Based alloys** - most common alloys are copper tin, copper lead, phosphor bronze: harder and stronger than white metal: can be used **un-backed as a solid bearing**.
- **Aluminum based alloys** - running properties not as good as copper based alloys but cheaper.
  - **Ptfe** - suitable in very light applications
  - **Sintered bronze** - Sintered bronze is a porous material which can be impregnated with oil, graphite or Ptfe. Not suitable for heavily loaded applications but useful where lubrication is inconvenient.
- **Nylon** - similar to Ptfe but slightly harder: used only in very light applications.

Triple-layer composite bearing material consists of 3 bonded layers: steel backing, sintered porous tin bronze interlayer and anti-wear surface as shown in figure 1.15. High load capacities and low friction rates, and are oil free and anti-wear.

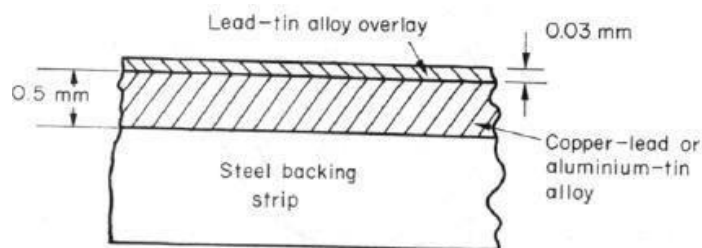

Fig.1.15 Tri-metal Bearing

If oil supply fails, frictional heating will rapidly increase the bearing temperature, normally lead to metal-to-metal contact and eventual seizure. Soft bearing material (low melting point) will be able to shear and may also melt locally. **Protects the journal** from severe surface damage, and helps to avoid component breakages (sudden locking of mating surfaces).

## 1.9 Petroff's Equation for lightly Loaded Bearings

The phenomenon of bearing friction was first explained by Petroff on the assumption that the shaft is concentric. This can happen when the radial load acting on the bearing is zero or very small, speed of the journal is very high and the viscosity of the lubricant is very high. Under these conditions, the eccentricity of the bearing (the offset between journal center and bearing center) is very small and the bearing could be treated as a concentric bearing as shown in figure 1.16

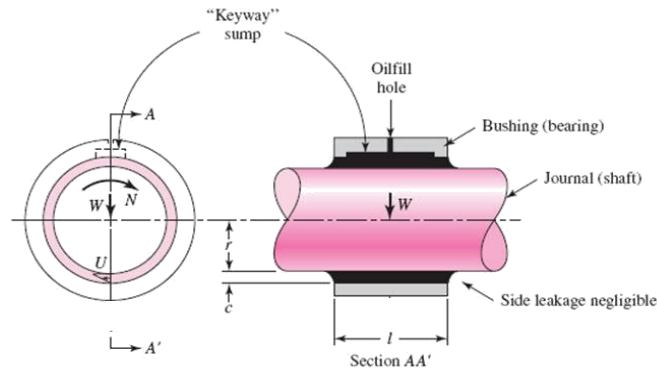

Fig.1.16 Concentric Bearing

Let us now consider a shaft rotating in a guide bearing. It is assumed that the bearing carries a very small load that the clearance space is completely filled with oil, and that leakage is negligible (Fig. 7.16). Let the radius of the shaft be  $r$ , and the length of the bearing by  $l$ . If the shaft rotates at  $N'$  rev/s, then its surface velocity is  $U = 2\pi r N'$ . Since the shearing stress in the lubricant is equal to the velocity gradient times the viscosity,

$$\tau = Z U/h = 2\pi r N' Z/c$$

where the radial clearance  $c$  has been substituted for the distance  $h$ .

$$F = \text{Frictional force} = \tau A = (2\pi r N' Z/c) (2\pi r l) = (4\pi^2 r^2 l Z N'/c)$$

$$\text{Frictional torque} = Fr = (4\pi^2 r^3 l Z N'/c)$$

The coefficient of friction in a bearing is the ratio of the frictional force  $F$  to the Radial load  $W$  on the bearing.

$$f = F/W = (4\pi^2 r^3 l Z N'/cW)$$

The unit bearing pressure in a bearing is given by  $p = W/2rL = \text{Load/ Projected Area of the Bearing}$ .

$$\text{Or } W = 2prL$$

Substituting this in equation for  $f$  and simplifying



$$f = 2m^2 (ZN'/p) (r/c)$$

This is the Petroff's equation for the coefficient of Friction in Lightly Loaded bearings.

### Example on lightly loaded bearings

E1. A full journal bearing has the following specifications:

- Journal Diameter: 46 mm
- Bearing length: 66 mm
- Radial clearance to radius ratio: 0.0015
- speed : 2800 r/min
- Radial load: 820 N.
- Viscosity of the lubricant at the operating temperature: 8.4 cP

Considering the bearing as a lightly loaded bearing, Determine (a) the friction torque (b) Coefficient of friction under given operating conditions and (c) power loss in the bearing.

### **Solution:**

Since the bearing is assumed to be a lightly loaded bearing, Petroff's equation for the coefficient of friction can be used.

$$f = 2m^2 (ZN'/p) (r/c)$$

$$N = 2800/60 = 46.66 \text{ r/sec.}$$

$$Z = 8.4 \text{ cP} = 8.4 \times 10^{-3}$$

$$Pa \cdot \text{sec } r = 46/2 = 23 \text{ mm} =$$

$$0.023 \text{ m}$$

$$P = w/2rL = 820 / (2 \times 0.023 \times 0.066) = 270092 \text{ Pa.}$$

Substituting all these values in the equation for f, **f = 0.019**

T = Frictional torque: Frictional force x Radius of the Journal

$$= (f W) r$$

$$= 0.019 \times 820 \times 0.023$$

$$= \mathbf{0.358 \text{ N-m}}$$

$$= 0.358 \times 46.66 / 1000$$

$$= \mathbf{0.016 \text{ kW}}$$

## 1.10 HYDRODYNAMIC JOURNAL BEARINGS Concept

The film pressure is created by the moving surface itself pulling the lubricant into a wedge-shaped zone at a velocity sufficiently high to create the pressure necessary to separate the surfaces against the load on the bearing.

One type occurs when the rate of shear across the oil film is a constant value and the line representing the velocity distribution is a straight line. In the other type the velocity distribution is represented by a curved line, so that the rate of shear in different layers across the oil film is different. The first type takes place in the case of two parallel surfaces having a relative motion parallel to each other as shown in Fig.1.19.

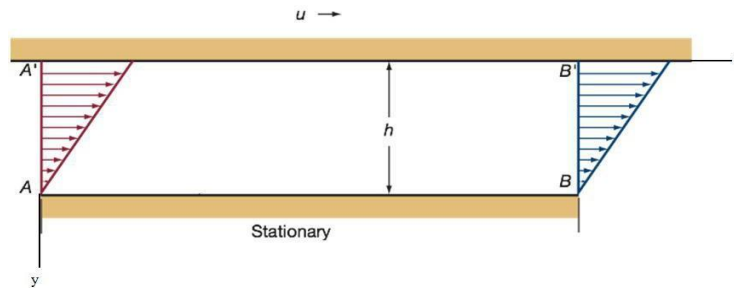

Fig. 1.19 Velocity profiles in a parallel-surface slider bearing.

There is no pressure development in this film. This film cannot support an external Load. The second type of velocity distribution across the oil film occurs if pressure exists in the film. This pressure may be developed because of the change of volume between the surfaces so that a lubricant is squeezed out from between the surfaces and the viscous resistance of flow builds up the pressure in the film as shown in Fig 1.20 or the pressure may be developed by other means that do not depend upon the motion of the surfaces or it may develop due to the combination of factors. What is important to note here is the fact that pressure in the oil film is always present if the velocity distribution across the oil film is represented by a curved line

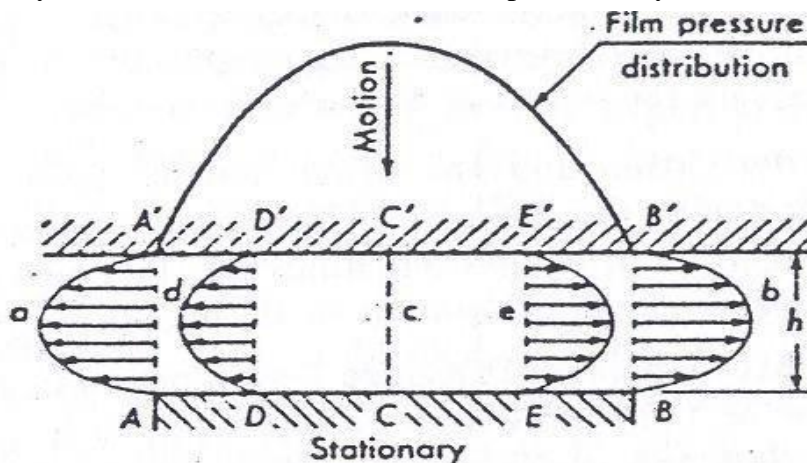

Fig.1.20 Flow between two parallel surface

Plate AB is stationary while A' B' is moving perpendicular to AB.  
 Note that the velocity distribution is Curvilinear. This is a pressure induced flow.  
 This film can support an External load.

**Hydrodynamic film formation**

Consider now the case of two non parallel planes in which one is stationary while the other is in motion with a constant velocity in the direction shown in Fig 1.21. Now consider the flow of lubricant through the rectangular areas in section AA' and BB' having a width equal to unity in a direction perpendicular to the paper.

The volume of the lubricant that the surface A'B' tends to carry into the space between the surfaces AB and A'B' through section AA' during unit time is AC'A'. The volume of the lubricant that this surface tends to discharge from space through section BB' during the same period of time is BD'B'. Because the distance AA' is greater than BB' the volume AC'A' is greater than volume BC'B' by a volume AEC'. Assuming that the fluid is incompressible and that there is no flow in the direction perpendicular to the motion, the actual volume of oil carried into the space must be equal to the discharge from this space. Therefore the excess volume of oil is carried into these space is squeezed out through the section AA' and BB' producing a constant pressure – induced flow through these sections.

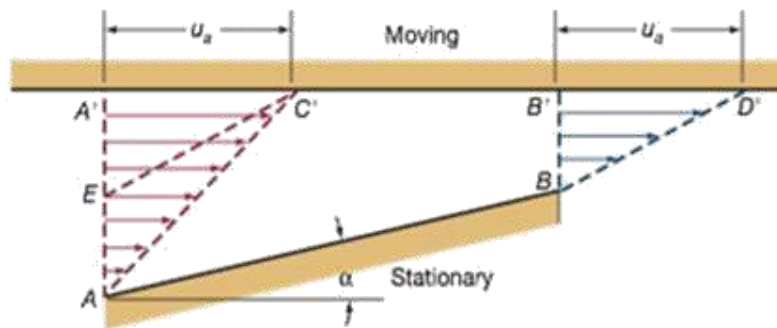

Fig.1.21 Velocity distribution only due to moving plate

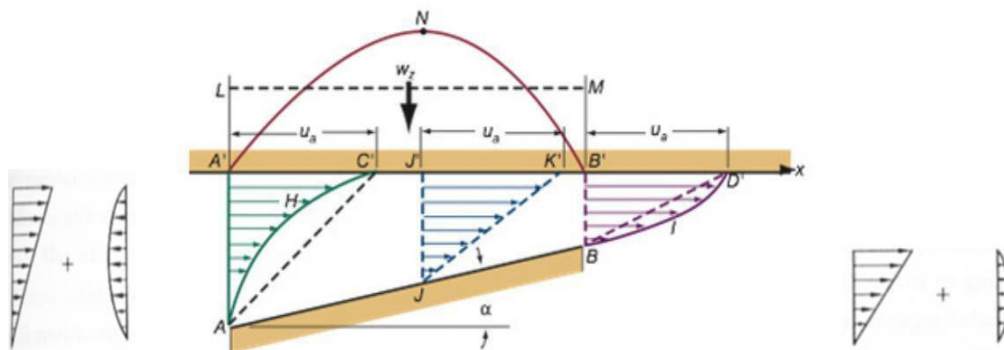

Fig.1.22 Resultant Velocity Distribution

The actual velocity distribution in section AA' and BB' is the result of the combined flow of lubricant due to viscous drag and due to pressure –induced flow. The resultant velocity distributions across these sections are as shown in Fig 1.22.

The curve A'NB' shows the general character of the pressure distribution in the oil film and the line LM shows the mean pressure in the oil film. Because of the pressure developed in the oil film the, plane A'B' is able to support the vertical load W applied to this plane, preventing metal to metal contact between the surfaces AB and A'B'. This load is equal to the product of projected area of the surface AB and mean pressure in the oil film.

### Conditions to form hydrodynamic lubrication

There must be a wedge-shaped space between two relative moving plates;

There must be a relative sliding velocity between two plates, and the lubricant must flow from big entrance to small exit in the direction of the moving plate;

The lubricant should have sufficient viscosity, and the supply of the lubricant is abundant.

### Formation of oil film in a Journal bearing

Imagine a journal bearing with a downward load on the shaft that is initially at rest and then brought up to operating speed. At rest (or at slow shaft speeds), the journal will contact the lower face of the bearing as shown in the figure 1.23. This condition is known as boundary lubrication and considerable wear can occur. As shaft speed increases, oil dragged around by the shaft penetrates the gap between the shaft and the bearing so that the shaft begins to “float” on a film of oil. This is the transition region and is known as thin-film lubrication. The journal may occasionally contact the bearing particularly when shock radial load occur. Moderate wear may occur at these times. At high speed, the oil film thickness increases until there comes a point where the journal does not contact the bearing at all. This is known as thick film lubrication and no wear occurs because there is no contact between the journal and the bearing.

The various stages of formation of a hydrodynamic film is shown in figure 1.23.

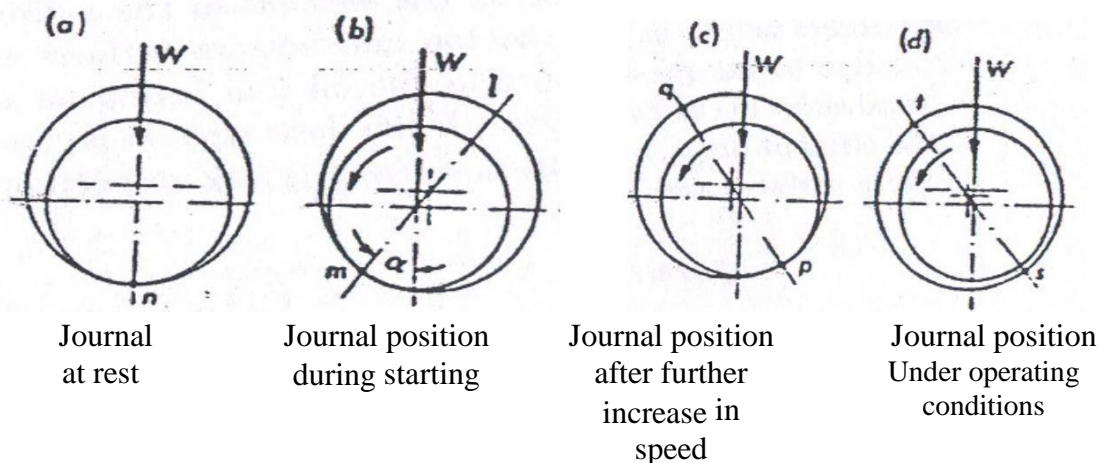

### Pressure distribution around an idealised journal bearing

A typical pressure distribution around the journal in a hydrodynamic bearing is as shown in the Fig. 1.24.

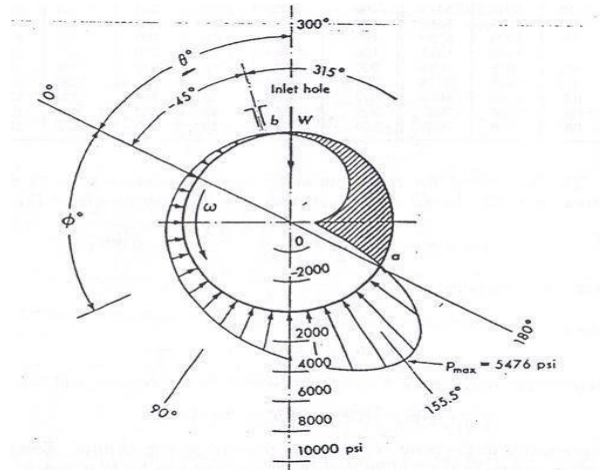
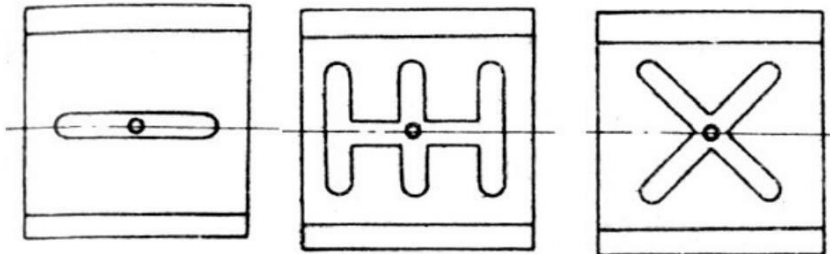

Fig.1.24 Bearing pressure distribution in a journal bearing

### Typical oil groove patterns



Some typical groove patterns are shown in the above figure. In general, the lubricant may be brought in from the end of the bushing, through the shaft, or through the bushing. The flow may be intermittent or continuous. The preferred practice is to bring the oil in at the center of the bushing so that it will flow out both ends, thus increasing the flow and cooling action.

### 1.13 Thermal aspects of bearing design

Heat is generated in the bearing due to the viscosity of the oil. The frictional heat is converted into heat, which increases the temperature of the lubricant. Some of the lubricant that enters

the bearing emerges as a side flow, which carries away some of the heat. The balance of the lubricant flows through the load-bearing zone and carries away the balance of the heat generated. In determining the viscosity to be used we shall employ a temperature that is the average of the inlet and outlet temperatures, or

$$T_{av} = (T_i + T_o) / 2$$

Where  $T_i$  = (T<sub>i</sub> + T<sub>o</sub>) is the inlet temperature and  $T$  is the temperature rise of the lubricant from inlet to outlet. The viscosity used in the analysis must correspond to  $T_{av}$ .

**Self contained bearings:**

These bearings are called *selfcontained* bearings because the lubricant sump is within the bearing housing and the lubricant is cooled within the housing. These bearings are described as *pillow-block* or *pedestal* bearings. They find use on fans, blowers, pumps, and motors, for example. Integral to design considerations for these bearings is dissipating heat from the bearing housing to the surroundings at the same rate that enthalpy is being generated within the fluid film.

**Heat dissipated based on the projected area of the bearing:**

Heat dissipated from the bearing, J/S  $H_D = CA (t_B - t_A)$

Where C= Heat dissipation coefficient from data hand book

Another formula to determine the heat dissipated from the

bearing  $H_D = ld (T + 18)^2 / K_3$

Where  $K_3 = 0.2674 \times 10^6$  for bearings of heavy construction and well ventilated =  
 $0.4743 \times 10^6$  for bearings of light construction in still air

$T = t_B - t_A$

Where,

$t_B$  = Bearing surface temperature

$t_A$  = Ambient temperature

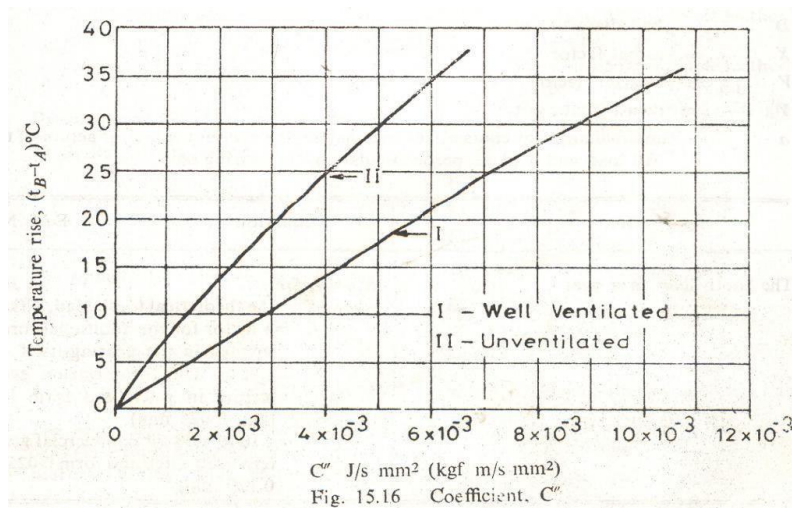

$C$  J/s mm<sup>2</sup> (kgf m/s mm<sup>2</sup>)  
 Fig. 15.16 Coefficient,  $C$

For good performance the following factors should be considered.

**Surface finish of the shaft (journal):** This should be a fine ground finish and preferably lapped.

**Surface hardness of the shaft:** It is recommended that the shaft be made of steel containing at least 0.35-0.45% carbon. For heavy duty applications shaft should be hardened.

**Grade of the lubricant:** In general, the higher the viscosity of the lubricant the longer the life. However the higher the viscosity the greater the friction, so high viscosity lubricants should only be used with high loads. In high load applications, bearing life may be extended by cutting a grease groove into the bearing so grease can be pumped in to the groove.

**Heat dissipation:** Friction generates heat and causes rise in temperature of the bearing and lubricant. In turn, this causes a reduction in the viscosity of the lubricating oil and could result in higher wear. Therefore the housing should be designed with heat dissipation in mind. For example, a bearing mounted in a Bakelite housing will not dissipate heat as readily as one mounted in an aluminium housing.

**Shock loads:** Because of their oil-cushioned operation, sliding bearings are capable of operating successfully under conditions of moderate radial shock loads. However excessive prolonged radial shock loads are likely to increase metal to metal contact and reduce bearing life. Large out of balance forces in rotating members will also reduce bearing life.

**Clearance:** The bearings are usually a light press fit in the housing. A shouldered tool is usually used in arbor press. There should be a running clearance between the journal and the bush. A general rule of thumb is to use a clearance of 1/1000 of the diameter of the journal.

**Length to diameter ratio (l/d ratio):** A good rule of thumb is that the ratio should lie in the range 0.5-1.5. If the ratio is too small, the bearing pressure will be too high and it will be difficult to retain lubricant and to prevent side leakage. If the ratio is too high, the friction will be high and the assembly misalignment could cause metal to metal contact.

### Examples on journal bearing design Example EI:

Following data are given for a 360° hydrodynamic bearing:

Radial load=3.2 kN  
Journal speed= 1490 r.p.m  
Journal diameter=50 mm  
Bearing length=50mm  
Radial clearance=0.05 mm  
Viscosity of the lubricant= 25 cP

Assuming that the total heat generated in the bearing is carried by the total oil flow in the bearing, calculate:

- Power lost in friction;
- The coefficient of friction;
- Minimum oil film thickness
- Flow requirement in l/min; and
- Temperature rise.

**Solution:**

$$P = W/Ld = 3.2 \times 1000 / (50 \times 50) = 1.28 \text{ MPa} = 1.28 \times 10^6$$

$$\text{Pa Sommerfeld number} = S = (ZN'/\rho) (r/c)^2$$

$$r/c = 25/0.05 = 500$$

$$Z = 25 \text{ cP} = 25 \times 10^{-3} \text{ Pa}\cdot\text{sec}$$

$$= 1490/60 = 24.833 \text{ r/sec. Substituting the above values, we get}$$

$$\mathbf{S = 0.121}$$

$$\text{For } S = 0.121 \text{ \& } L/d = 1,$$

$$\text{Friction variable from the graph} = (r/c) f = 3.22$$

$$\text{Minimum film thickness variable} = h_o/c = 0.4$$

$$\text{Flow variable} = Q/rcN L = 4.33$$

$$f = 3.22 \times 0.05 / 25 = 0.0064$$

$$\text{Frictional torque} = T = fWr = 0.0064 \times 3200 \times 0.025 \\ = 0.512 \text{ N}\cdot\text{m}$$

$$\text{Power loss in the Bearing} = 2\pi N T / 1000 \text{ kW} \\ = 0.080 \text{ kW}$$

$$h_o = 0.4 \times 0.05 = 0.02 \text{ mm}$$

$$Q/rcN L = 4.33 \text{ from which}$$

$$\text{we get, } Q = 6720.5 \text{ mm}^3 / \text{sec.}$$

Ex

2 Determination of dimensionless variables is shown in the following figures.

Assume that all the heat generated due to friction is carried away by the lubricating oil.

$$\text{Heat generated} = 80 \text{ watt} = mC_p T$$

where:

$$m = \text{mass flow rate of lubricating oil} = \rho Q \text{ in}$$

$$\text{kg/sec } C_p = \text{Specific heat of the oil} = 1760 \text{ J/kg } ^\circ\text{C}$$

$$T = \text{temperature rise of the oil}$$

$$\rho = 860 \times 10^{-9} \text{ kg/mm}^3$$

Substituting the above values,

$$T = 7.9 \text{ } ^\circ\text{C}$$

$$\text{The Average temperature of the oil} = T_i + T/2 = 27 + (7.9/2) = 30.85 \text{ } ^\circ\text{C}$$



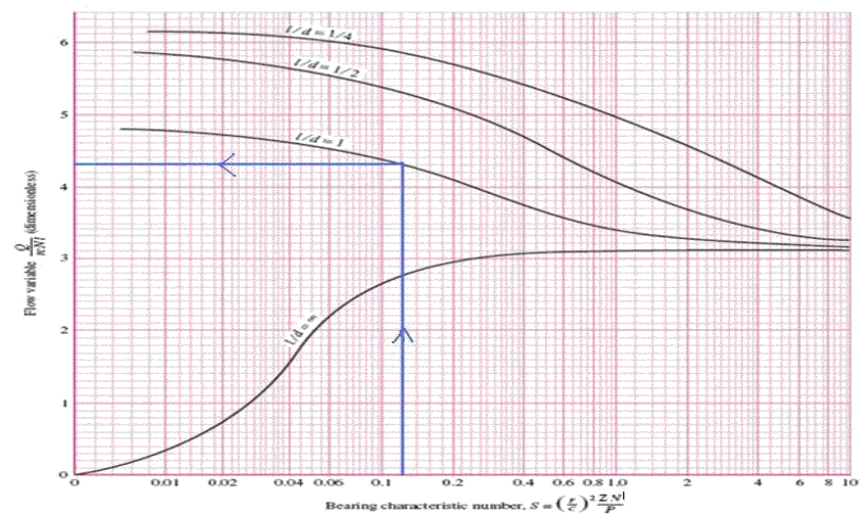
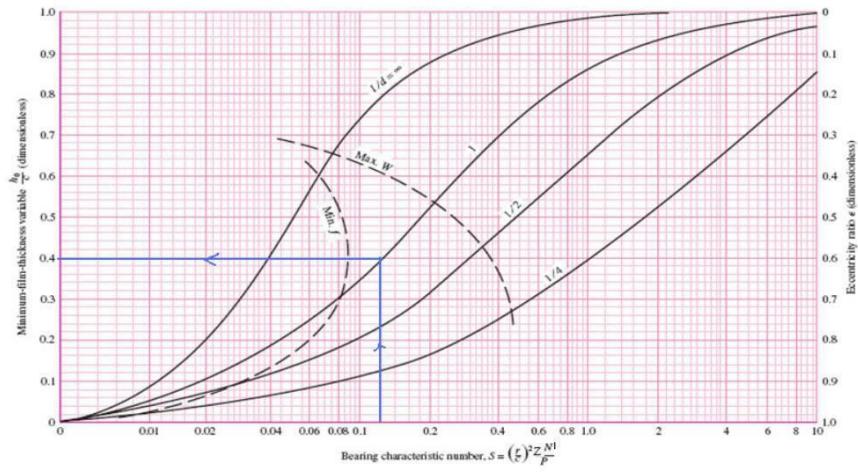
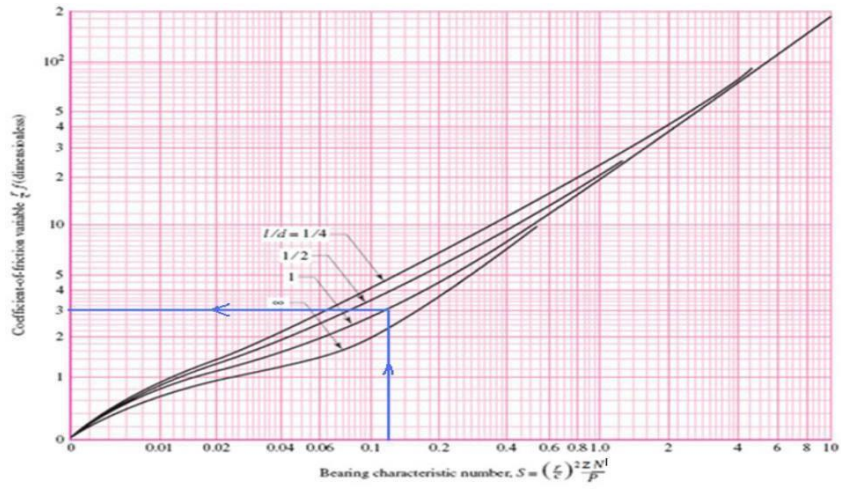

### **Example E2:**

A 50 mm diameter hardened and ground steel journal rotates at 1440 r/min in a lathe turned bronze bushing which is 50 mm long. For hydrodynamic lubrication, the minimum oil film thickness should be five times the sum of surface roughness of journal bearing. The data about machining methods are given below:

Machining method	surface Roughness (c.l.a)
Shaft grinding	1.6 micron
Bearing turning/boring	0.8 micron

The class of fit is H8d8 and the viscosity of the lubricant is 18 cP. Determine the maximum radial load that the journal can carry and still operate under hydrodynamic conditions.

### **Solution:**

Min. film thickness =  $h_o = 5 [0.8+1.6] = 12 \text{ micron} = 0.012 \text{ mm}$   
For H8 d8 fit, referring to table of tolerances,  
 $\text{Ø}50 \text{ H8} = \text{Min. hole limit} = 50.000 \text{ mm}$   
 $\text{Max.hole limit} = 50.039 \text{ mm}$

Mean hole diameter = 50.0195 mm

$\text{Ø} 50 \text{ d8} = \text{Max.shaft size} = 50 - 0.080 = 49.920 \text{ mm}$

$\text{Min. shaft size} = 50 - 0.119 = 49.881 \text{ mm}$

Mean shaft diameter = 49.9005 mm.

Assuming that the process tolerance is centered,  
Diametral clearance =  $50.0195 - 49.9005 = 0.119 \text{ mm}$   
Radial clearance =  $0.119/2 = 0.0595 \text{ mm}$

$h_o / c = 0.012 / 0.0595 = 0.2$

$L/d = 50/50 = 1$

From the graph, Sommerfeld number = 0.045

$$S = (ZN'/p) (r/c)^2 = 0.045$$

$$r/c = 25/0.0595 = 420.19$$

$$Z = 18 \text{ cP} = 18 \times 10^{-3}$$

$$\text{Pa.sec } N' = 1440/60 = 24$$

r/sec

From the above equation, Bearing pressure can be calculated.

$$p = 1.71 \times 10^6 \text{ Pa} = 1.71 \text{ MPa.}$$

The load that the bearing can carry:

$$W = pLd = 1.71 \times 50 \times 50 = 4275 \text{ N}$$

**Example E3:**

The following data are given for a full hydrodynamic journal bearing:

Radial load=25kN

Journal speed=900 r/min.

Unit bearing pressure= 2.5 MPa

(l/d) ratio= 1:1

Viscosity of the  
lubricant=20cP Class of  
fit=H7e7

- Calculate: 1. Dimensions of bearing  
2. Minimum film thickness and  
3. Requirement of oil flow

**Solution:**

$$N' = 900/60 = 15 \text{ r/sec}$$

$$P = W/Ld$$

$$2.5 = 25000/Ld = 25000/d^2$$

As  $L=d$ .

$$\mathbf{d = 100 \text{ mm} \ \& \ L = 100 \text{ mm}}$$

For H7 e7 fit, referring to table of tolerances,

$$\text{\O}100 \text{ H7} = \text{Min. hole limit} = 100.000 \text{ mm}$$

$$\text{Max. hole limit} = 100.035 \text{ mm}$$

$$\text{Mean hole diameter} = 100.0175 \text{ mm}$$

$$\text{\O}100 \text{ e7} = \text{Max. shaft size} = 100 - 0.072 = 99.928 \text{ mm}$$

$$\text{Min. shaft size} = 100 - 0.107 = 99.893 \text{ mm}$$

$$\text{Mean shaft diameter} = 99.9105 \text{ mm}$$

**Assuming that the process tolerance is centered,**

$$\mathbf{\text{Diametral clearance} = 100.0175 - 99.9105 = 0.107}$$

$$\mathbf{\text{mm Radial clearance} = 0.107/2 = 0.0525 \text{ mm}}$$

Assume  $r/c = 1000$  for general bearing applications.

$$C = r/1000 = 50/1000 = 0.05 \text{ mm.}$$

$$Z = 20 \text{ cP} = 20 \times 10^{-3}$$

$$\text{Pa. sec } N' = 15 \text{ r/sec}$$

$$P = 2.5 \text{ MPa} = 2.5 \times 10^6 \text{ Pa}$$

$$\mathbf{S = (ZN'/p) (r/c)^2 = 0.12}$$

For  $L/d=1$  &  $S=0.12$ , Minimum Film thickness variable=  $h_o/c = 0.4$

$$\mathbf{h_o = 0.4 \times 0.05 = 0.02 \text{ mm}}$$

**Example E4:**

A journal bearing has to support a load of 6000N at a speed of 450 r/min. The diameter of the journal is 100 mm and the length is 150mm. The temperature of the bearing surface is limited to 50 °C and the ambient temperature is 32 °C. Select a suitable oil to suit the above conditions.

**Solution:**

$N^1 = 450/60 = 7.5$  r/sec,  $W=6000$  N,  $L=150$ mm,  $d=100$  mm,  $t_A = 32$  °C,  $t_B = 50$  °C.

Assume that all the heat generated is dissipated by the bearing.

Use the Mckee's Equation for the determination of coefficient of friction.

$$f = \text{Coefficient of friction} = K_a (ZN^1/p) (r/c) 10^{-10} + f$$

$$p = W/Ld = 6000/100 \times 150 = 0.4 \text{ MPa.}$$

$$K_a = 0.195 \times 10^6 \text{ for a full bearing } f = 0.002$$

$$r/c = 1000 \text{ assumed}$$

$$U = 2\pi r N^1 = 2 \times 3.14 \times 50 \times 7.5 = 2335 \text{ mm/sec} = 2.335 \text{ m/sec.}$$

$$f = 0.195 \times 10^6 \times (Z * 7.5 / 0.4) \times 1000 \times 10^{-10} + 0.002$$

$$f = 0.365Z + 0.002$$

$$\text{Heat generated} = f * W * U$$

$$\text{Heat generated} = (0.365Z + 0.002) \times 6000 \times 2.335$$

Heat dissipated from a bearing surface is given by:

$$H_D = ld (T+18)^2 / K_3$$

Where  $K_3 = 0.2674 \times 10^6$  for bearings of heavy construction and well ventilated =  $0.4743 \times 10^6$  for bearings of light construction in still air

$$T = t_B - t_A = 50 - 32 = 18^\circ\text{C}$$

$$H_D = 150 \times 100 (18+18)^2 / 0.2674 \times 10^6 = 72.7 \text{ Watt}$$

$H_D = H_g$  for a self-contained bearing.

$$72.7 = (0.365Z + 0.002) \times 6000 \times 2.335$$

$$Z = 0.0087$$

$$\text{Pa. Sec}$$

Relation between oil temp, Amb. temp, & Bearing surface temperature is given by  $t_B - t_A = \frac{1}{2} (t_O - t_A)$

$$t_O = \text{oil temperature} = 68^\circ\text{C}$$

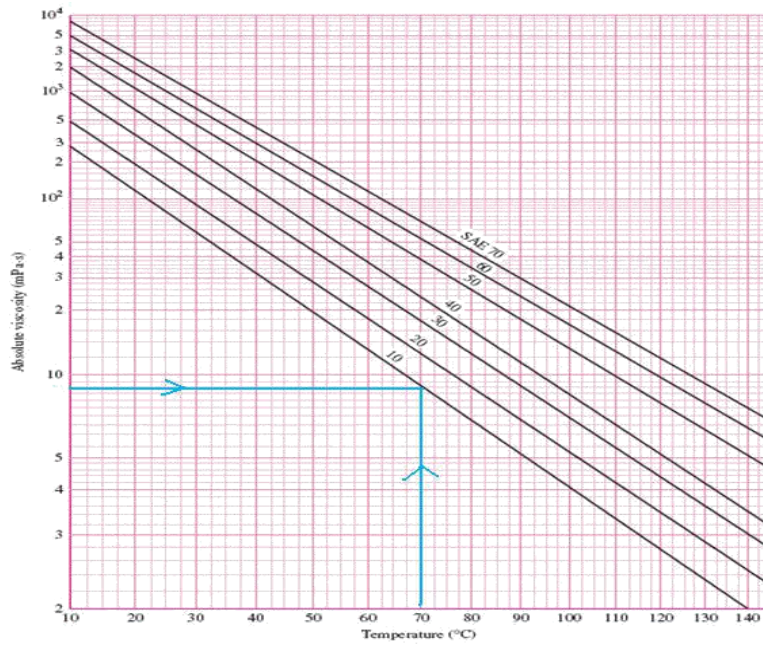

Select SAE 10 Oil for this application

## UNIT 2

### DESIGN OF I.C ENGINE PARTS

#### INTRODUCTION :

The internal combustion engine, shortly called as I.C Engine is one type of engines in which the thermal and chemical energies of combustion are released inside the engine cylinder. There is another type of heat engine called External combustion engine. For example steam engine, combustion takes place outside the engine cylinder and the thermal energy is first transmitted to water outside the cylinder and steam is produced and then this energized steam is injected inside the cylinder for further operation.

The I.C engines are commonly operated by petrol even fuels like petrol, diesel and sometimes by gas. Depending on the properties of these fuels, the construction of concerned engines may be slightly changed from one to another. But , whatever be the type of engines, they have the following basic components which are i) Cylinder ii) Piston iii) Connecting rod iv) Crank shaft and v) flywheel. Apart from these main elements they have some auxiliary parts like push rod, cams, valves, and springs and so on.

The I.C Engines are employed in many places like in small capacity power plants, Industries and laboratory machines and their outstanding applications are in the field of transportation like automobiles, air-crafts, rail-engines, ships and so on.

#### CLASSIFICATION OF I.C ENGINES

The I.C Engines are classified in many ways such as according to fuel used, method of ignition, work cycles, cylinder arrangement of applications etc.:

- a) According to fuel used
  - i) Petrol Engine
  - ii) Diesel Engine
  - iii) Gas Engine
- b) According to method of ignition
  - i) Spark ignition engine
  - ii) Compression ignition engine
- c) According to working cycle
  - i) Four stroke engine
  - ii) Two stroke engine
- d) According to cylinder arrangement
  - i) Horizontal engine
  - ii) Vertical engine
  - iii) Inline engine
  - iv) v-engine
  - v) Radial engine

e) According to field of applications

i) Automobile engine

ii) Motor cycle engine

iii) Aero engine

iv) Locomotive engine

v) Stationary engine

## IC ENGINE TERMINOLOGY:

The following terms/Nomenclature associated with an engine are explained for the better understanding of the working principle of the IC engines

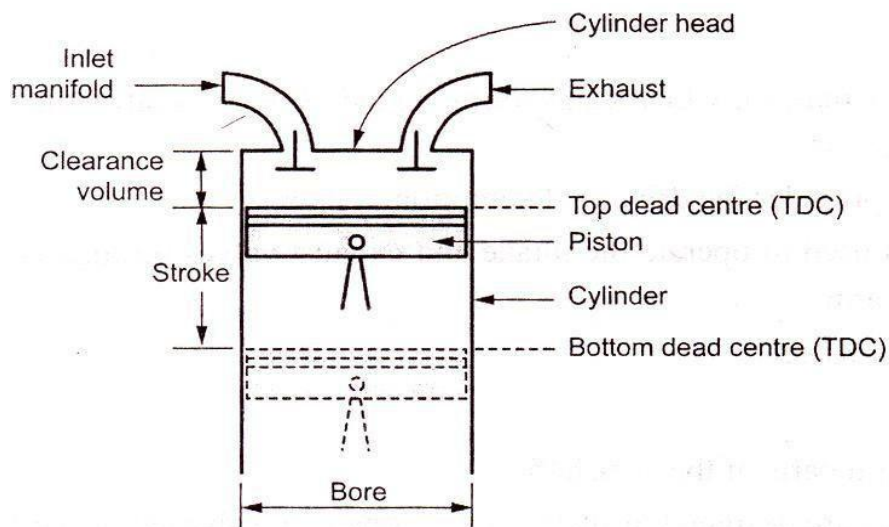

**1. BORE:** The nominal inside diameter of the engine cylinder is called bore.

**2. TOP DEAD CENTRE (TDC):** The extreme position of the piston at the top of the cylinder of the vertical engine is called top dead center (TDC), In case of horizontal engines. It is known as inner dead centre (IDC).

**3. BOTTOM DEAD CENTRE (BDC):** The extreme position of the piston at the bottom of the cylinder of the vertical engine called bottom dead centre (BDC).In case of horizontal engines, it is known as outer dead center (ODC).

**4. STROKE:** The distance travelled by the piston from TDC to BDC is called stroke. In other words, the maximum distance travelled by the piston in the cylinder in one direction is known as stroke. It is equal to twice the radius of the crank.

**5. CLEARANCE VOLUME (V<sub>c</sub>):** The volume contained in the cylinder above the top of the piston, when the piston is at top dead centre is called the clearance volume.

**6. SWEPT VOLUME (V<sub>s</sub>):** The volume swept by the piston during one stroke is called the swept volume or piston displacement. Swept volume is the volume covered by the piston while moving from TDC to BDC.

i.e. Swept volume = Total volume – clearance volume

**7. COMPRESSION RATIO (RC):** Compression ratio is a ratio of the volume when the piston is at bottom dead centre to the volume when the piston is at top dead centre.

Mathematically,

$$\begin{aligned} \text{Compression ratio} &= \frac{\text{Maximum cylinder volume}}{\text{Maximum cylinder volume} - \text{Clearance volume}} \\ &= \frac{\text{Swept volume} + \text{clearance volume}}{\text{Clearance volume}} \end{aligned}$$



## **ENGINE-CYLINDER:**

At the time of compression and power strokes , more pressure is produced by the fuel-gas inside the cylinder. In order to with stand this high pressure, the cylinder ,cylinder head and piston should be fabricated with robust construction. The cylinder should also have the capacity to resist high temperature produced at the time of power stroke. It should be able to transfer the unused heat efficiency so as to escape from reaching the melting temperature of cylinder material.

During operation of the engine, the piston slides inside the cylinder millions of times and thus the inside wall of the cylinder may be worn out. Since the cylinder is made as the integral part of the engine, the removal of the cylinder for repairing to rectify the wear by re-boring etc. will be very tedious and not economical and hence the cylinder is provided with another thin cylindrical piece called liner fitted concentric with the axis of the cylinder, by doing so worn out liner can easily replaced by new liner. Also by using strong liner, the good quality and strong material equal to that of liner material, need not be used for the entire cylinder and engine and thus the engine cost may be reduced. In the case of large sized engine, the cylinder with water jacket for cooling purpose.

**MATERIALS :** The cylinder and liner should be made of such a material which is strong enough to with stand high gas pressure and at the same time sufficiently hard enough to resist wear due to piston movement. It should also be capable of resisting thermal stresses due to heat flow through the liner-wall. In order to meet out the above requirements, the cylinder is usually made grey cast-iron and liners are made of nickel cast-iron, nickel chromium cast iron ,nickel chromium cast steel and so on.

## CYLINDER LINER

The cylinders are provided with cylinder liners so that in case of wear, they can be easily replaced. The cylinder liners are of the following two types :

1. Dry liner, and
2. Wet liner.

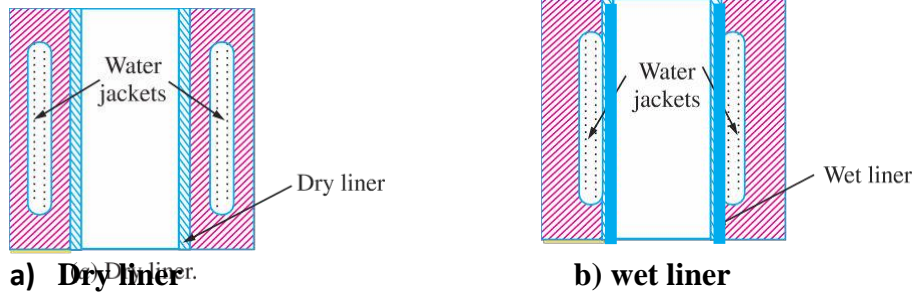

A cylinder liner which does not have any direct contact with the engine cooling water, is known as **dry liner**, as shown in Fig. (a). A cylinder liner which have its outer surface in direct contact with the engine cooling water, is known as **wet liner**, as shown in Fig. (b). The cylinder liners are made from good quality close grained cast iron (*i.e.* pearlitic cast iron), nickel cast iron, nickel chromium cast iron. In some cases, nickel chromium cast steel with molybdenum may be used. The inner surface of the liner should be properly heat-treated in order to obtain a hard surface to reduce wear.

## DESIGN OF ENGINE CYLINDER

When designing a new engine, heat analysis must be carried out to determine analytically the basic parameters of the engine under design with a sufficient degree of accuracy. This involves choice of data like engine type, power and speed, number and arrangement of cylinders, cylinder size, stroke bore ratio, piston speed and compression ratio etc.

Usually the piston speed and speed factor categorise the engine into high speed engine or low speed engine. The speed factor is defined as

$$C_s = \frac{0.3VN}{10^5}$$

Where V = piston speed in m/min

N = Crank shaft speed in r.p.m

The maximum piston speed for various applications is taken as follows

Air craft engines 750 to 1000 m/min

Heavy duty stationary engines 450 to 750 m/min

Large gas and diesel engines 300 to 450 m/min

The engines are classified as

- i) Low speed engine if  $C_s$  is less than 3
- ii) Medium speed engine if  $C_s$  is between 3 to 9
- iii) High speed engine if  $C_s$  is between 9 to 27
- iv) Super speed engine if  $C_s$  is greater than 27.

The recommended piston speeds and the stroke-bore ratio for different types of engines are taken from Jalal data book page number 15.12

Now considering the design of engine cylinder, when the gas expands inside the cylinder, two types of stresses will be induced in the walls of the cylinder liner which are

- i) Tensile stress due to gas pressure and
- ii) Thermal stress due to enormous heat.

By selecting the high heat resisting material, the thermal stresses can be reduced to the maximum extent.

The gas pressure also produces two types of tensile stresses in the cylinder namely) Longitudinal stress and b) Circumferential stress which act at right angle to each other. We have already known that when the pressure vessel like boiler or engine cylinder is subjected to gas pressure the induced circumferential stress (hoop stress) will be more than the induced longitudinal stress and hence the cylinder is based on circumferential (hoop) stress.

The wall thickness of cylinder is usually calculated by applying thin cylinder

formula. Then the wall thickness of cylinder,

$$t = \frac{pD}{2\sigma_t} + C$$

where  $p$  = maximum pressure of fuel-gas inside the cylinder

$D$  = Inside diameter of cylinder (or) bore dia

$\sigma_t$  = Allowable tensile stress of cylinder material  $\text{N/mm}^2$

= (50 to 60  $\text{N/mm}^2$  for C.I Engine & 80 to 100  $\text{N/mm}^2$  for steel)

Where  $C$  = 6 to 12 mm to account for blow holes, corrosion and re-boring etc

The thickness of the cylinder wall usually varies from 4.5 mm to 25 mm, or more depending upon the cylinder size.

The other parameters are empirically found out as follows

The thickness of liner  $t_l = 0.03D$  to  $0.035D$

The thickness of jacket wall is given by,

$$t_j = 0.032D \text{ to } 1.6 \text{ mm}$$

The water space between the outer cylinder wall and the inner jacket wall is given by

$$t_w = 0.08D \text{ to } 6.5 \text{ mm}$$

The cylinder is usually attached to the upper half of the crank case with the help of flanges, studs and nuts.

The flange thickness is obtained as,

$$t_f = (1.2 \text{ to } 1.4) t$$

where  $t$  = cylinder thickness

The stud or bolt diameter can be evaluated by comparing the tensile strength of all bolts at their root diameters to the gas load such as

$$n \cdot \frac{\pi}{4} \cdot d_c^2 \cdot \sigma_{tb} = \frac{\pi \cdot D^2 \cdot p}{4}$$

where

$d_c$  = core (i.e., root) diameter of bolt or stud

$\sigma_{tb}$  = Allowable tensile strength of bolt material = (80 N/mm<sup>2</sup> to 100 N/mm<sup>2</sup>)

$n$  = Number of studs = (0.01D to 0.02D) + 4

The thickness of cylinder head may be calculated as

$$t = kD \sqrt{\frac{p}{2\sigma_{th}}}$$

where  $k$  = constant = 0.5

$\sigma_{th}$  = Allowable tensile stress of head material = (30 to 50 N/mm<sup>2</sup>).

## PISTON

The piston is a disc which reciprocates within a cylinder. It is either moved by the fluid or it moves the fluid which enters the cylinder. The main function of the piston of an internal combustion engine is to receive the impulse from the expanding gas and to transmit the energy to the crankshaft through the connecting rod. The piston must also disperse a large amount of heat from the combustion chamber to the cylinder walls.

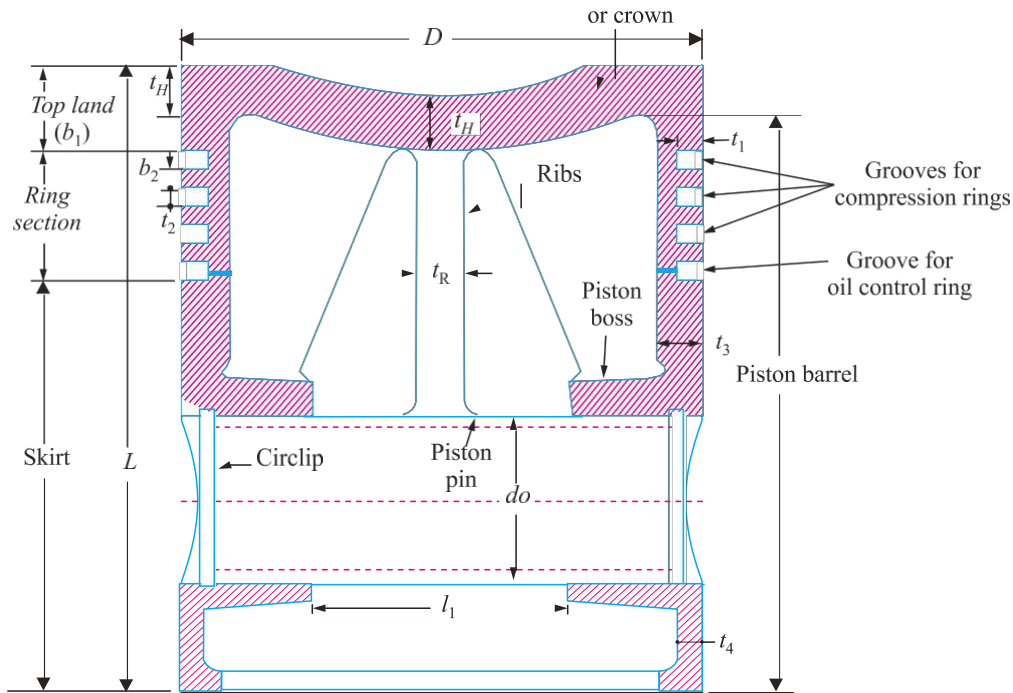

**Fig.Piston for i.c Engine**

The piston of internal combustion engines are usually of trunk type as shown in Fig.32.3. Such pistons are open at one end and consists of the following parts:

**HEAD OR CROWN.** The piston head or crown may be flat, convex or concave depending upon the design of combustion chamber. It withstands the pressure of gas in the cylinder.

**PISTON RINGS.** e piston rings are used to seal the cylinder in order to prevent leakage of the gas past the piston.

**SKIRT.** The skirt acts as a bearing for the side thrust of the connecting rod on the walls of cylinder.

**PISTON PIN.** It is also called *gudgeon pin* or *wrist pin*. It is used to connect the piston to the connecting rod.

### DESIGN CONSIDERATIONS FOR A PISTON

In designing a piston for I.C. engine, the following points should be taken into consideration :

1. It should have enormous strength to withstand the high gas pressure and inertia forces.
2. It should have minimum mass to minimise the inertia forces.
3. It should form an effective gas and oil sealing of the cylinder.
4. It should provide sufficient bearing area to prevent undue wear.
5. It should disperse the heat of combustion quickly to the cylinder walls.
6. It should have high speed reciprocation without noise.
7. It should be of sufficient rigid construction to withstand thermal and mechanical distortion.
8. It should have sufficient support for the piston pin.

### PISTON MATERIALS

Since the piston is subjected to highly rigorous conditions, it should have enormous strength and heat resisting properties to withstand high gas pressure. Its construction should be rigid enough to withstand thermal and mechanical distortion. Also the piston should be operated with least friction

and noiseless. The material of the piston must possess good wear resisting operating temperature and it should be corrosive resistant.

The most commonly used materials for the pistons of I.C engines are cast-iron, cost- aluminum, forged aluminum, cast steel and forged steel. Cast iron pistons are used for moderate speed i.e below 6m/s and aluminum pistons are employed for higher piston speeds greater than 6 m/s.

## DESIGN OF PISTON

When designing a piston, the following points must be considered such as

1. Adequate strength to withstand high pressure produced by the gas.
2. Capacity of piston to withstand high temperature.
3. Scaling of the working space against escape of gases.
4. Good dissipation of heat to the cylinder wall
5. Sufficient projected area (i.e surface area) and rigidity of the barrel.
6. Minimum loss of power due to friction.
7. Sufficient length to have better guidance and so on.

The dimensions of various parts of the trunk-type piston are determined as follows.

## PISTON HEAD

The piston head or crown is designed keeping in view the following two main considerations, *i.e.*

1. It should have adequate strength to withstand the straining action due to pressure of explosion inside the engine cylinder, and
2. It should dissipate the heat of combustion to the cylinder walls as quickly as possible.

On the basis of first consideration of straining action, the thickness of the piston head is determined by treating it as a flat circular plate of uniform thickness, fixed at the outer edges and subjected to a uniformly distributed load due to the gas pressure over the entire Cross-section.

Based on strength consideration, the thickness of the piston head ( $t_1$ ), according to Grashoff's formula is given by

$$t_1 = \sqrt{\frac{3p_m D^2}{16\sigma_{tp}}} \text{ mm}$$

where  $p_m$  = Maximum gas pressure  $\text{N/mm}^2$

$D$  = Allowable of piston or cylinder bore (mm)

$\sigma_{tp}$  = Allowable tensile stress of the piston material

= 35 to 40  $\text{N/mm}^2$  for cast iron

= 60 to 100  $\text{N/mm}^2$  for steel

= 50 to 90  $\text{N/mm}^2$  for aluminum alloy

Based on heat dissipation, the head thickness is determined as,

$$t_1 = \frac{1000H}{12.56 k(T_c - T_e)} \text{ mm}$$

where H= Heat following through the head (KW)

$$H = C \times m \times C_v \times P_B$$

C =Constant (Usually 0.05). It is the piston of the hat supplied to the engine which is absorbed by the piston.

m = mass of the fuel used (i.e fuel consumption) (kg/kw/s)

$C_v$  = Higher calorific value of the fuel(KJ/kg)

$$= 44 \times 10^3 \text{ KJ/kg for diesel fuel}$$

$$= 11 \times 10^3 \text{ KJ/kg for petrol fuel.}$$

$P_B$  = Brake power of the engine per cycle (KW)

$$= \frac{P_{mb} L A n}{60000000} \text{ kw}$$

$P_{mb}$ = Brake mean effective pressure (N/mm<sup>2</sup>)

L= stroke length (mm)

A= Area of piston at its top side (mm<sup>2</sup>)

n= Number of power strokes per minute

K= Heat conductivity factor (kw/m/<sup>0</sup>C)

$$= 46.6 \times 10^{-3} \text{ for cast iron}$$

$$= 51 \times 10^{-3} \text{ for steel}$$

$$= 175 \times 10^{-3} \text{ for aluminum alloys}$$

$T_c$ = Temperature at the centre of piston head (<sup>0</sup>C)

$T_e$ = Temperature at the edge of piston head (<sup>0</sup>C)

$$= 75^{\circ}\text{C for aluminum alloys}$$

### **RIBS:**

To make the piston rigid and to prevent distortion due to gas load and connecting rod, thrust, Four to six ribs are provided at the inner of the piston.

The thickness of rib is assumed as  $t_2 = (0.3 \text{ to } 0.5)t_1$

Where  $t_1$  is thickness of the piston head.

### **PISTON RINGS:**

To maintain the seal between the piston and the inner wall of the cylinder, some split-rings

called as piston rings are employed. By making such sealing the escape of gas through piston side-wall to the connecting rod side can be prevented. The piston rings also serve to transfer the heat from the piston head to cylinder walls.

With respect to the location of piston rings, they are called as top rings, or bottom rings. Rings inserted at the top of the piston side wall are compression rings which may be 3 to 4 for automobiles and air craft engines and 5 to 7 for stationary compression ignition engines. Rings inserted at the bottom of the piston side wall are oil scraper rings, used to scrap the oil from the surface liner so as to minimize the flow of oil into the combustion chamber. The number of oil scraper rings may be taken as 1 to 3. In the oil rings, the bottom edge is stepped to drain the oil.

The compression rings (i.e top side piston rings) are made of rectangular cross-section and their diameters are made slightly larger than the bore diameter. A part of the ring is cut off in order to permit the ring to enter into the cylinder liner.=

Due to difference of diameters between the piston rings and liner, a pressure is exerted on the liner by the piston rings. Sufficient clearance should be given, between the cut ends (i.e free ends) of the piston-rings in order to prevent the ends contact at high temperature by thermal expansion.

Usually the piston rings are made of alloy cast iron with chromium plated to possess good wear resisting qualities and spring characteristics even at high temperatures. When designing on the liner wall should be limited between  $0.025 \text{ N/mm}^2$  and  $0.042 \text{ N/mm}^2$ .

Let  $t_3$  = radial thickness of piston

rings  $t_4$  = Axial thickness of piston

rings

$p_c$  = contact pressure (i.e wall pressure) in  $\text{N/mm}^2$

Now radial  
thickness

$$t_3 = D \sqrt[3]{\frac{3p_c}{\sigma_{br}}} \text{ mm}$$

and the axial thickness  $t_4 = (0.7 \text{ to } 1) t_3$

or by empirical relation

$$t_4 = \frac{D}{10i}$$

where  $D$  = Bore diameter mm

$\sigma_{br}$  = Allowable bending stress of ring material  $\text{N/mm}^2$  = Alloy cast iron 84 to 112

$\text{N/mm}^2$   $i$  = Number of rings.

Due to some advantages like, better scaling action, less wear of lands etc., usually thinner rings are preferred. The first ring groove is cut at a distance of  $t_1$  to  $1.2t_1$  from top. The lands between the rings may be equal to or less than the axial thickness of ring  $t_4$ . The gap between the free ends of the ring is taken as

$$C = (3.5 \text{ to } 4) t_3$$

Where  $t_3$  is the radial thickness of ring.



### PISTON BARREL:

The cylindrical portion of the piston is termed as piston barrel. The barrel thickness may be varied (usually reduced) from top side to bottom side of the piston. The maximum thickness of barrel nearer to piston head is given by,  $t_5 = 0.03D + b + 4.5$  mm

Where  $b$  = radial depth of ring-groove  $b = t_3 + 0.4$  mm

The thickness of barrel at the open end of the piston,  $t_6 = (0.25 \text{ to } 0.35) t_5$  mm

### PISTON SKIRT

The portion of the piston barrel below the ring selection upto the open end is called as portion-skirt. The piston skirt takes up the thrust of the connecting rod. The length of the piston skirt is selected in such a way that the side thrust pressure should not exceed  $0.28 \text{ N/mm}^2$  for slow speed engines and  $0.5 \text{ N/mm}^2$  for high speed engines.

The side thrust force is given by,

$$F_s = \mu F_g$$

Where  $\mu$  = coefficient of friction between lines and skirt =  $(0.03 \text{ to } 0.1)$

$$F_g = \text{Gas force} = \frac{\pi}{4} D^2 p_m$$

$$\text{The side thrust pressure, } p_s = \frac{\text{side thrust force}}{\text{projected area}} = \frac{F_c}{L_c * D}$$

$$\text{Length of skirt (} L_s) = \frac{F_c}{p_c * D} \text{ where } D = \text{Bore diameter.}$$

### LENGTH OF PISTON

The length of piston,  $L_p$  can be obtained as

$$L_p = L_s + \text{Length of ring section} + \text{Top land}$$

$$\text{Empirically } L_p = D \text{ to } 1.5D$$

### GUDGEON PIN or PISTON PIN

The piston pin should be made of case hardened alloy steel containing nickel, chromium, molybdenum etc with ultimate strength of  $700 \text{ to } 900 \text{ N/mm}^2$  in order to withstand high gas pressure. The piston pin is designed based on the bearing pressure consideration.

Let  $l$  = length of piston pin,  $d$  = diameter of piston pin,  $p_b$  = Allowable bearing pressure for piston pin =  $15 \text{ to } 30 \text{ N/mm}^2$ .

Bearing strength of piston pin  $F_b$  = Bearing pressure x Projected area

$$F_b = p_b \cdot l \cdot d$$

By equating this bearing strength to gas force  $G_g$ , we get

$$P_b.l.d = F_g \text{ (there fore } F_g = \frac{\pi D^2 p}{4} \text{ )}$$

Usually,  $l/d = 1.5$  to  $2$ .

The piston pin is checked for bending as, the induced bending stress

$$\sigma_b = \frac{32M}{\pi d^3} < \sigma_b$$

where  $M =$  Bending moment  $\frac{F_g D}{8}$   
 $=$

$D =$  Bore diameter

$F_g =$  gas force

$\sigma_b =$  Allowable bending stress =  $84 \text{ N/mm}^2$  for case hardened steel and  $140 \text{ N/mm}^2$  for heat treated alloy steel

The gudgeon pin is fitted at a distance of  $(L_s/2)$  from open end where  $L_s$  is the skirt-length.

### PISTON CLEARANCE

**Proper clearance** must be provided between the piston and liner to take care of thermal expansion and distortion under load. Usually the clearance may be between  $0.04 \text{ mm}$  to  $0.20 \text{ mm}$ , depending upon the engine design and piston dia. small clearance may be adopted for the pistons cooled by oil (or) water.

### DESIGN OF A CONNECTING ROD

The connecting rod is the intermediate member between the piston and the crankshaft. Its primary function is to transmit the push and pull from the piston pin to the crankpin and thus convert the reciprocating motion of the piston into the rotary motion of the crank. The usual form of the connecting rod in internal combustion engines is shown in Fig. 32.9. It consists of a long shank, a small end and a big end. The cross-section of the shank may be rectangular, circular, tubular, *I*-section or *H*-

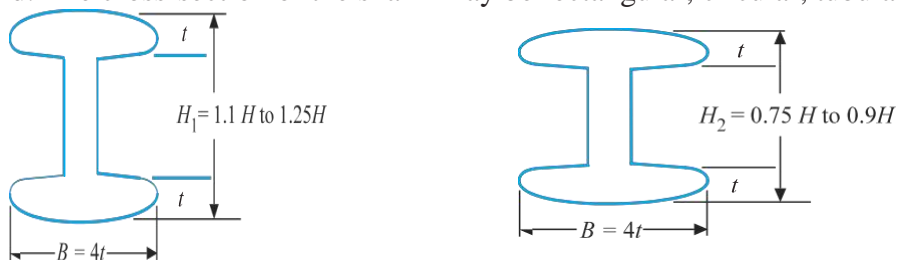

Section. Generally circular section is used for low speed engines while *I*-section is preferred for high speed engines

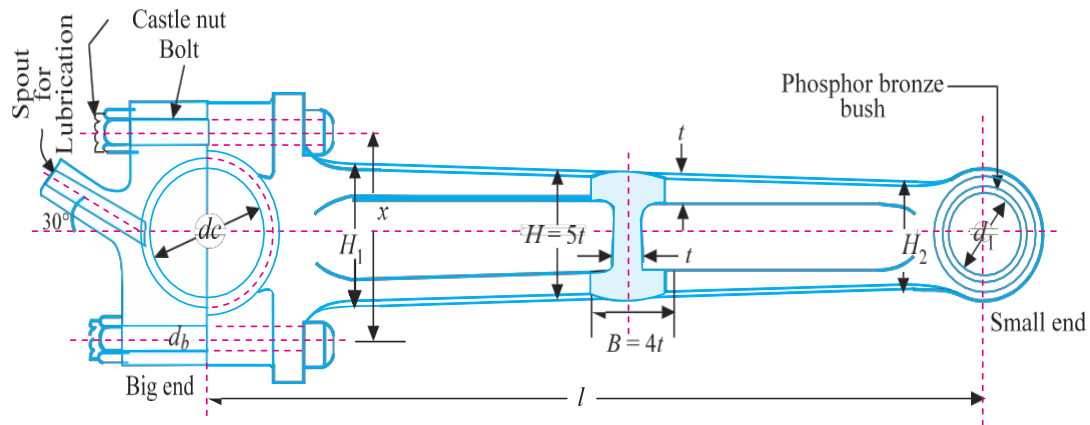

The \*length of the connecting rod ( $l$ ) depends upon the ratio of  $l / r$ , where  $r$  is the radius of crank. It may be noted that the smaller length will decrease the ratio  $l / r$ . This increases the angularity of the connecting rod which increases the side thrust of the piston against the cylinder liner which in turn increases the wear of the liner. The larger length of the connecting rod will increase the ratio  $l / r$ . This decreases the angularity of the connecting rod and thus decreases the side thrust and the resulting wear of the cylinder. But the larger length of the connecting rod increases the overall height of the engine. Hence, a compromise is made and the ratio  $l / r$  is generally kept as 4 to 5.

The small end of the connecting rod is usually made in the form of an eye and is provided with a bush of phosphor bronze. It is connected to the piston by means of a piston pin.

The big end of the connecting rod is usually made split (in two \*\*halves) so that it can be mounted easily on the crankpin bearing shells. The split cap is fastened to the big end with two cap bolts. The bearing shells of the big end are made of steel, brass or bronze with a thin lining (about 0.75 mm) of white metal or Babbitt metal. The wear of the big end bearing is allowed for by inserting thin metallic strips (known as *shims*) about 0.04 mm thick between the cap and the fixed half of the connecting rod. As the wear takes place, one or more strips are removed and the bearing is trued up.

The connecting rods are usually manufactured by drop forging process and it should have adequate strength, stiffness and minimum weight. The material mostly used for connecting rods varies from mild carbon steels (having 0.35 to 0.45 percent carbon) to alloy steels (chrome-nickel or chrome-molybdenum steels). The carbon steel having 0.35 percent carbon has an ultimate tensile strength of about 650 MPa when properly heat treated and a carbon steel with 0.45 percent carbon has an ultimate tensile strength of 750 MPa. These steels are used for connecting rods of industrial engines. The alloy steels have an ultimate tensile strength of about 1050 MPa and are used for connecting rods of aero engines and automobile engines.

The bearings at the two ends of the connecting rod are either splash lubricated or pressure lubricated. The big end bearing is usually splash lubricated while the small end bearing is pressure lubricated. In the **splash lubrication system**, the cap at the big end is provided with a dipper or spout and set at an angle in such a way that when the connecting rod moves downward, the spout will dip into the lubricating oil contained in the sump. The oil is forced up the spout and then to the big end bearing. Now when the connecting rod moves upward, a splash of oil is produced by the spout. This

splashed up lubricant find its way into the small end bearing through the widely chamfered holes provided on the upper surface of the small end.

In the **pressure lubricating system**, the lubricating oil is fed under pressure to the big end bearing through the holes drilled in crankshaft, crank webs and crank pin. From the big end bearing, the oil is fed to small end bearing through a fine hole drilled in the shank of the connecting rod. In some cases, the small end bearing is lubricated by the oil scrapped from the walls of the cylinder liner by the oil scraper rings.

### FORCES ACTING ON THE CONNECTING ROD

The various forces acting on the connecting rod are as follows:

1. Force on the piston due to gas pressure and inertia of the reciprocating parts,
2. Force due to inertia of the connecting rod or inertia bending forces,
3. Force due to friction of the piston rings and of the piston, and
4. Force due to friction of the piston pin bearing and the crankpin bearing.

We shall now derive the expressions for the forces acting on a vertical engine, as discussed below.

#### 1. Force on the piston due to gas pressure and inertia of reciprocating parts

Consider a connecting rod  $PC$  as shown in Fig. 32.10.

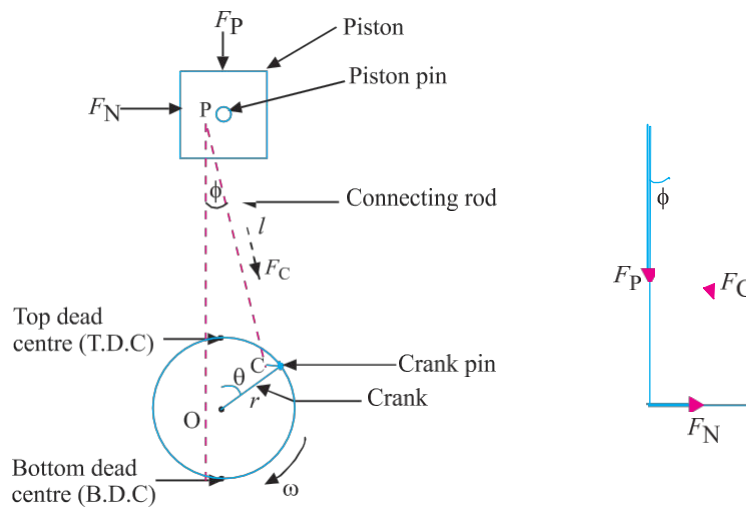

Let

$p$  = Maximum pressure of gas,

$D$  = Diameter of piston,

$A_p$  = Cross-section area of piston

$MR$  = Mass of reciprocating parts,

$r$  = radius of crank shaft

$\omega$  = Angular speed of crank,

$\phi$  = Angle of inclination of the connecting rod with the line of stroke,

$\Theta$  = Angle of inclination of the crank from top dead centre,

$r$  = Radius of crank,

$l$  = Length of connecting rod, and

$n$  = Ratio of length of connecting rod to radius of crank =  $l / r$ .

$F_{op}$  = Force acting on the piston =  $p \times$

$A_p$   $F_c$  = Force acting on the connecting rod

$F_i$  = Inertia force due to weight of the reciprocating parts

we know that the force on the piston due to pressure of gas,

$$F_{op} = \text{Pressure} \times \text{Area} = p \cdot A_p = p \times \pi D^2 / 4$$

And the inertia force of the reciprocating parts

$F_i$  = mass  $\times$  Acceleration

$$= \frac{M_r}{g} \times \omega^2 r (\cos \Theta + (\cos 2\Theta) / n)$$

The net load acting on the connecting rod,  $F_c = F_p \pm F_i$

The -ve sign is used when the piston moves from TDC to BDC and +ve sign is used when the piston moves from BDC to TDC.

When weight of the reciprocating parts is to be considered, then

$$F_c = F_p \pm F_i \pm W_r$$

The actual axial load acting on the connecting rod will be more than the net load due to the angularity of the rod.

Now, the force acting on the connecting rod at any instant is given by

$$F_c = \frac{F_p - F_i}{\cos \alpha} = \frac{F_p}{\cos \alpha \phi}$$

Normally inertia force due to the weight of reciprocating parts is very small, it can be neglected when designing connecting rod

$$F_c = \frac{F_p}{\cos \alpha \phi}$$

Since the piston is under reciprocating action, the connecting rod will be subjected to maximum force when the crank angle  $\Theta = 90^\circ$  and for other positions, the force values are reduced and for  $\Theta = 0^\circ$  and  $\Theta = 180^\circ$ , the forces are zeros. Also the inclination of the connecting rod  $\phi = \phi_{\max}$  when  $\Theta = 90^\circ$ . Hence the maximum force acting on the connecting rod, is given by

$$F_{c_{\max}} = \frac{F_p}{\cos \alpha \phi}$$

In general,  $n$  should be at least 3

Hence for  $n=1/r=3$ ,

$F_c=1.06F_p$   $N=4$ ,  $F_c=1.03F_p$

$N=5$ ,  $F_c=1.02F_p$

Maximum bending moment due to inertia force is given by the relation  $M_{max}=m.\omega^2 .\frac{S}{9\sqrt{3}}$

Where  $m$ = mass of connecting rod

$\omega$  = Angular speed in rad/s

$L$ = length of connecting

rod  $R$  = radius of crank

The maximum bending stress =  $\frac{M_{max}}{Z}$

Where  $Z$  = section modulus.

### **DIMENSIONS OF CONNECTING ROD ENDS**

Now the other parts of connecting rod such as its small end, big end and bolts are designed as follows

The small end is made as solid eye without any split and is provided with brass bushes inside the eye and the big end is split and the top cap is joined with the remaining parts of connecting rod by means of bolts. By this set up the connecting rod can be dismantled without removing the crank shaft. In the big end also, the brass bushes of split type are employed.

The parameters of small end and big end are determined based on the bearing pressures

Let  $l_1$ ,  $d_1$ =length and diameter of piston (i.e small end respectively)

$L_2$ ,  $d_2$  = Length and diameter of crank pin (i.e big end respectively)

$P_{b1}$ ,  $P_{b2}$  = Design bearing pressures for the small end and big end respectively

Bearing load applied on the piston pin(i.e small end) is given by

$$F_1 = P_{b1}.l_1.d_1$$

And the bearing load applied on the crank pin (i.e big end) is given by  **$F_2 = P_{b2}.L_2.d_2$**

Usually the design bearing pressure for the small end and big end may be taken as,

$$P_{b1} = 12.5 \text{ to } 15.4 \text{ N/mm}^2$$

$$P_{b2} = 10.8 \text{ to } 12.6 \text{ N/mm}^2$$

Similarly, the ratio of length to diameter for small end and big end may be assumed as,

$$L_1/d_1=1.5 \text{ to } 2, L_2/d_2= 1.0 \text{ to } 1.25$$

Usually, low design stress value is selected for big end than that for small end.

The biggest load to be carried by these for bearings containing piston pin and crank pin is the maximum compressive load produced by the gas pressure neglecting the inertia force due to its small value

At the same time, the bolts are designed based on the inertia force of the reciprocating parts which is given by

$$\text{Inertia force } F_i = m r \omega^2 \left( \cos \theta + \frac{\cos 2\theta}{n} \right)$$

$$n = \frac{s}{r} = \frac{\text{Length of connecting rod}}{\text{radius}}$$

The maximum inertia force will be obtained when the crank shaft is at dead centre position, i.e., at  $\theta = 0$ .

By equating this maximum inertia force to the tensile strength of bolts and their core diameters, the size of bolts may be determined.

$$\text{For two bolts } F_{im} = 2 \times \frac{\pi}{4} d_c^2 \times S_t$$

The nominal diameter may be selected from the manufacture's table (usually  $d_c = 0.84 d_b$ , where  $d_b$  is the nominal dia of bolt).

The cap is usually treated as a beam freely supported at the bolts centre's and loaded in a manner intermediate between uniformly distributed load and centrally concentrated loaded.

$$\text{Maximum bending moment at the centre of cap is given by } M = w l^1 / 6$$

Where  $w$  = maximum load equal to inertia force of reciprocating parts =  $F_{im}$

$$\text{Hence } M = F_{im} l^1 / 6$$

$l^1$  = Distance between bolts centers

$$= \text{Diameter of crank pin} + (2 \times \text{wall thickness of bush}) + \text{dia of bolt} + \text{some extra marginal thickness.}$$

Width of cap may be calculated as,

$$b = \text{length of crank pin} - 2 \times \text{flange thickness of bush}$$

usually, the wall thickness and flange thickness of bush may be taken as about 5 mm.

Bending stress induced in the cap =  $S_{be} = M / Z$ .

Where  $Z$  = Section modulus of the cap.

$$Z = 1/6 \cdot b \cdot t_c^2$$

Where  $t_c$  = Thickness of cap.

By comparing this induced bending stress with the design stress, the thickness of cap may be evaluated.

### **DESIGN PROCEDURE FOR CONNECTING ROD:**

For the design of connecting rod, the following steps may be observed.

1. From the statement of problem, note the pressure of steam or gas, length of connecting rod, crank radius etc.,. Then select suitable material usually mild steel for the connecting rod and find its design stresses. Assume the essential non given data suitably based on the working conditions.
2. Select I-section connecting rod if possible and determine its moment of inertia about x-axis and y-axis.
3. Equate the steam force with buckling strength of connecting rod using Rankine's formula and determine the dimensions of connecting rod.
4. Calculate the maximum bending stress and then compare it with design stress of the connecting rod for checking.

### **SLENDERNESS RATIO:**

It is the ratio of the length of column ( $l$ ) to its least radius of gyration ( $k$ )

Slenderness ratio =  $l/k$

If  $l/k < 40$  – then design of connecting rod be based on compressive load.

If  $l/k > 40$  – then design of connecting rod may be based on buckling load.

### **BUCKLING LOAD or CRIPPLING LOAD**

**The piston rod and connecting rod are designed mainly** based on compressive failure load. Since the length of rods are more, they can buckle during compression, which is also considered as functional failure. That is, the compressive load which causes buckling of piston rod



or connecting rod is called as buckling load or crippling load. For proper functioning without buckling the piston rod or connecting rod should be subjected to a compressive load which is less than crippling load.

When the connecting rod or piston rod are subjected to compressive load, they may fracture when the applied compressive load is more than their resisting compressive strength. At the same time, if the length of rods have been increased beyond certain limit with respect to their gross sectional dimensions (i.e  $l/k > 40$ ) the rods may buckle for lower values of compressive load known as buckling load. This buckling load also considered as functional failure. Usually design of connecting & piston rod are designed based on buckling load.

## CRANK SHAFT

A crank shaft (i.e a shaft with a crank) is used to convert reciprocating motion of the piston into rotary motion or vis versa. The crank shaft consists of the shaft parts which revolve in the main bearings, the crank pins to which the big ends of the connecting are connected, the crank arms or webs (also called cheeks) which connect the crank pins and the shaft parts. The crankshaft, depending upon the position of crank, may be divided into the following two types.

1. Side crank shaft
2. centre crank shaft.

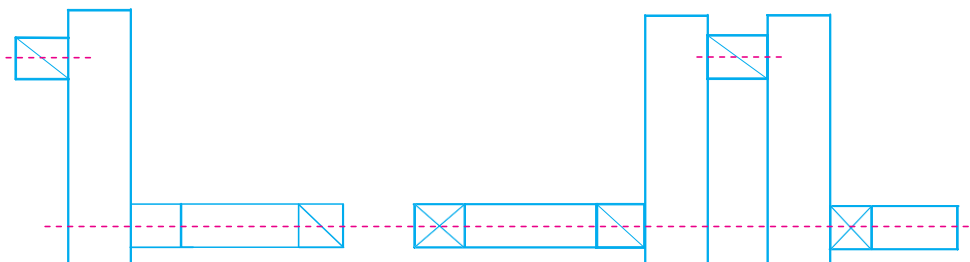

The crankshaft, depending upon the number of cranks in the shaft, may also be classified as single throw or multi-throw crankshafts. A crank shaft with only one side crank or centre crank is called a **single throw crankshaft** whereas the crankshaft with two side cranks, one on each end or with two or more centre cranks is known as **multi-throw crankshaft**.

The side crankshafts are used for medium and large size horizontal engines.

## MATERIAL AND MANUFACTURE OF CRANKSHAFTS

The crankshafts are subjected to shock and fatigue loads. Thus material of the crankshaft should be tough and fatigue resistant. The crankshafts are generally made of carbon steel, special steel or special cast iron.

In industrial engines, the crankshafts are commonly made from carbon steel such as 40 C 8, 55 C 8 and 60 C 4. In transport engines, manganese steel such as 20 Mn 2, 27 Mn 2 and 37 Mn 2 are generally used for the making of crankshaft. In aero engines, nickel chromium steel such as 35 Ni 1 Cr 60 and 40 Ni 2 Cr 1 Mo 28 are extensively used for the crankshaft.

The crankshafts are made by drop forging or casting process but the former method is more common. The surface of the crankpin is hardened by case carburizing, nitriding or induction hardening.

### DESIGN OF OVERHUNG CRANKSHAFT

Overhung crank shaft or side crankshaft of one crank pin, one shaft part (i.e Journal) and one web which connects the crank pin with the journal. When designing the crankshaft, it is required to discuss about the nature of stresses induced in various parts of the crankshaft.

Let

F = Force transmitted from connecting rod to the crankshaft

A = Area of cross section of crank pin

L = Length of crank pin

d = Diameter of crank pin

w – width of crank web

t = Thickness of crank web

r = Distance between axes of crankpin and journal (i.e crank

radius) x = Distance between the centers of crank pin and journal

$\Theta$  = Angle of inclination of crank from inner dead centre

$\phi$  = Angle of inclination of the connecting rod with the line of stroke

$\beta$  = Angle between crank and connecting rod

Fr = radial component of force

Ft = Tangential component of force

Sb = Allowable bending stress

Ss = Allowable shear stress

Sc = Allowable crushing (or) bearing stress.

### STRESS INDUCED IN THE CRANKPIN

**When the force is transmitted from the connecting rod to the crankshaft, the crankpin is subjected to three types of stresses namely,**

- i) **Plain shear stress due to direct shear force**
- ii) **Bending stress at the fixed end due to the bending moment**
- iii) **Crushing (or) bearing stress acting over the projected area**

**At any** crank angle  $\Theta$ , the force  $F$  can be resolved into radial component of force  $F_r$ , and tangential component of force  $F_t$ . Their magnitudes are

$$F_r = F \cos(\Theta + \phi) \text{ and } F_t = F \sin(\Theta + \phi)$$

In the case of crank pin, these components of force will not produce any effect on the pin and hence, for the design of crankpin, the actual force  $F$  may be considered for all positions of the crank.

Now, the various stresses induced in the crankpin are evaluated as follows.

$$\text{Plain shear stress } S_s = F / A = 4 F / \pi d^2$$

Bending moment at the fixed end  $M = F \times (l/2)$

(Assuming the force is acting at the centre of pin)

$$\begin{aligned} \text{Hence bending stress } S_b &= 32M / \pi d^3 \\ &= 16Fl / \pi d^3 \end{aligned}$$

Bending stress  $S_c = \text{Force} / \text{projected Area} = F / l.d$

It is found that the bearing pressure is a limiting factor in design as it insures proper lubrication.

### **STRESSES INDUCED IN THE CRANK WEB**

Since the force acting on the crank web is having different values for different positions of the crank with respect to the line of stroke, the web is designed based on maximum loading conditions. Usually two positions of crank may be considered for the web design, that is, at zero crank angle and when the included angle between connecting rod and the crank web is  $90^\circ$ . When  $\Theta = 0$ , the radial component  $F_r = F$  and tangential component  $F_t = 0$ . Similarly when  $\beta = 90^\circ$ ,  $F_t = F$ , and  $F_r = 0$ . For other positions of crank, the force is resolved into radial and tangential components and the corresponding induced stresses are evaluated properly.

The various induced stresses in the web at any crank angle are AS FOLLOWS.

- I) Direct (or) axial stress by radial force
- II) Bending stress due to radial force
- III) Bending stress due to tangential force.

$$\text{Direct stress } S_o = F_r / w.t$$

Bending stress induced in the web due to eccentric application of radial force,

$$S_{br} = M / Z$$

$$\text{i.e } S_{br} = (Fr(1/2 + t/2)) / ((1/6) \times wt^2)$$

$$= 3Fr(1 + t) / wt^2$$

Bending stress induced in the web nearer to the main journal,

$$S_{bt} = M / Z = Ft.r / ((1/6) \times w^2t)$$

$$= 6Ft.r / t.w^2$$

Resultant maximum stress acting on the web,

$$S = S_o + S_{br} + S_{bt}.$$

### **STRESSES INDUCED IN THE CRANK-SHAFT MAIN JOURNAL**

The main journal of the crank shaft is also designed similar to web based on induced bending and torsional stresses corresponding to maximum loading positions. The induced stresses on the main journal are

- I) Bending stress due to radial force
- II) Bending stress due to tangential force
- III) Torsional shear stress due to tangential force

Bending stress due to radial force,

$$S_{br} = 32M/D^3\pi = 32F_r.x / \pi D^3$$

Bending stress due to tangential force,

$$S_{bt} = 32M / \pi D^3 = 32 F_t.x / \pi D^3$$

These two bending stresses are acting at right angles and hence the resultant bending stress is given by

$$S_b = \sqrt{S_{br}^2 + S_{bt}^2} = 32 / \pi D^3 (\sqrt{F_r^2 + F_t^2}.x) = 32 F_x / \pi D^3$$

Torsional shear stress due to tangential force,

$$S_s = 16T / \pi D^3 = 16F_t.r / \pi D^3$$

Since the main journal is subjected to bending stress and shear stress, the induced equivalent bending stress and shear stress must be found out.

$$\text{Equivalent bending stress, } S_{be} = \frac{1}{2} [ S_b + \sqrt{S_b^2 + 4S_s^2} ]$$

$$\text{Equivalent shear stress } S_{se} = \frac{1}{2} [ \sqrt{S_b^2 + 4S_s^2} ]$$

Also the main journal must be checked for bearing pressure. For the optimum design of crankshaft, the dimensions of crank shaft parts are selected in such a way that the induced stresses should be less than their allowable values.

### **DESIGN OF CENTRE CRANK SHAFT**

In this type of crankshaft, one crank pin is supported by two webs and the webs are fitted with main journals at both ends. Since the crankshaft resembles a simply supported beam with central loading, the force received from the connecting rod is shared equally by the two journals and the maximum bending moment is developed at the centre of crank pin.

Centre crank shaft is divided into single crank type (or single throw ) and multi crank type (or multi throw) depending upon the number of crank pins , which may be employed in single cylinder engine or multi-cylinder engine. For the single throw and multi throw crankshafts, the number of crankpins, webs and the main journals required are as follows.

If we consider as

$n_p$  = Number of crank pins

$n_w$  = Number of webs

$n_j$  = Number of main journals.

Then for single throw crank shaft.

$n_p = 1, n_w = 2, n_j = 2.$

For multi throw crankshaft, the number of main journals is usually one more than the number of crankpins. However, the number of main journals and web can be reduced, excluding some between the crankpins, if the rigidity of the crankshaft is increased sufficiently.

i.e for multi throw crank shaft, (say, for four crank model)

$n_p = 4, n_w = 2, n_j = 8, n_j = n_p + 1 = 5$

(or)  $n_p = 4, n_w = 6, n_j = 3$  (in special case)

Similarly for six crank model

$n_p = 6, n_w = 2n_p = 12, n_j = n_p + 1 = 7$  or  $n_p = 6, n_w = 10, n_j = 5$ .

### **DSIGN OF SINGLE THROW CRANK SHAFT**

The single throw crank shaft consists of one crank pin, two webs and two main journals which are rotating inside the main bearings.

The stresses induced in various parts are discussed as follows.

Let

F = Force applied by the connecting rod to the crank shaft.

A = Area of cross-section of crank pin

L = Length of crank pin

D = Diameter of crank pin

L = Length of main

journal

D = Diameter of main

journal W = width of crank

web

T = Thickness of crank

web R = Radius of crank

X = Distance between centers of main journals

Fr = Radial component of force

Ft = Tangential component of force

The centre crank shaft may be considered as a simply supported beam, loaded at the centre (i.e. at the crank pin) and supported at the bearings.

Since the force F is shared by the two journals equally the reaction on each journal is  $F/2$  and the maximum bending moment is developed at the centre of crank pin and is equal to  $(\frac{F_s}{4})$

### **STRESSES INDUCED IN THE CRANK PIN**

In this case also, the crank pin is subjected to three types of stresses, similar to overhung crank shaft.

They are

- i) plain shear stress (or transverse shear stress) due to direct shear force at the area of cross-section.  $S_s = F/A = 4F/\pi d^2$
- ii) Bending stress due to bending moment at the centre of the pin  
 $S_b = 32M/\pi d^3 = 8Fx/\pi d^3$

iii) Bearing stress over the projected area,

$$S_c = F/l.d$$

### STRESSES INDUCED IN THE CRANK WEB

Since this crank shaft is containing two webs, the force supplied by the connecting rod is shared by these two webs equally and hence the force applied on one web is only half of force. The induced stresses are

- i) Direct axial stress by the radial force,  
 $S_o = Fr/wt$
- ii) Bending stress due to radial force,  

$$S_{br} = \frac{M}{Z} = \frac{\text{force} \times \text{Distance of action}}{\text{section modulus}} = \frac{Fr \left[ \frac{x}{2} - \left( \frac{l}{2} \right) \right]}{\frac{1}{6}tw^2}$$

$$= \frac{3Fr[s-(S+t)]}{wt^2}$$

- iii) Bending stress induced by the tangential force,  

$$S_{bt} = \frac{M}{Z} = \frac{Ft.r}{\frac{1}{6}tw^2} = \frac{6Ft.r}{tw^2}$$

Total resultant stress induced on the web,

$$S = S_o + S_{br} + S_{bt}$$

Here radial force  $Fr = \frac{F}{2} \cos(\Theta + \phi)$

And tangential force,  $Ft = \frac{F}{2} \sin(\Theta + \phi)$

### STRESSES INDUCED IN THE CRANK SHAFT MAIN JOURNAL

Since the centre crank shaft is similar to simply supported beam, the bending moment at the journals is zero. Hence the possible induced stress is due to twisting moment produced by the tangential force.

The torsional shear stress,  $S_s = \frac{16T}{\pi D^3} = \frac{16Ft.r}{\pi D^3}$

$$\text{Where } F_t = \frac{F}{2} \sin (\Theta + \phi)$$

Sometimes fly wheels may be connected at the end of journal. For such cases, the bending moment produced by the weight of the fly wheel on the journal may be taken into account for the design consideration.

### DESIGN OF MAIN BEARINGS

The main bearings, into which the crankshaft journals are rotating, are designed based on the bearing pressure developed over the projected area.

If D = Diameter of

bearing L = Length of

bearing

$$\text{Then bearing pressure, } p_b = \frac{\text{Load}}{\text{Projected area}} = \frac{M}{L.D}$$

Where W = F for overhung crank shaft

and W = F/2 for centre crank shaft.

### DESIGN OF MULTI-THROW CRANK SHAFT

Since the multi throw crankshaft is simply the multiple structure of single throw crank shaft, the design of multi-throw crank shaft is very similar to the design of single throw crankshaft.

In this, case, since all the cylinders of the engine possess equal capacity, the force supplied by one cylinder is used for designing one portion of the crank shaft, (i.e one set of crank pin web and journal etc.) and for the remaining portions, the same design values are adopted.

### DESIGN STRESS VALUES

All parts of crankshaft (i.e crank pin, web & journal) are made of same material and hence they must have common design stress values. Usual design stress values for the crank shaft material (I.e for mild steel) are

i)	In bending	:	60 to 100 Mpa
ii)	In torsion & compression	:	80 to 120 Mpa
iii)	In shear	:	40 to 60 Mpa
iv)	In bearing	:	10 to 20 Mpa

The design bearing pressure for the bearings are

i)	In crank pin	:	4 to 12 Mpa
ii)	In main shaft	:	1.5 to 2 Mpa



## STEPS INVOLVED IN THE DESIGN OF CRANKSHAFT

1. From the given problem, identify the type of crankshaft to be designed, material, steam, or gas pressure and other given parameters.
2. Determine the maximum load acting on the crank pin, maximum torque and bending moments.
3. Find out the parameters of crankpin such as its length, and diameter etc. based on the bearing pressure and check the induced bending and shear stresses with their allowable values.
4. Design the main journal (i.e shaft) based on maximum torque and bending moment conditions and check the bearing pressure.
5. Select the web parameters proportionately and check their induced stresses.
6. In any case, if the induced stress is more than the allowable value, then alter the corresponding dimensions suitably.
7. Usually the following proportions are adopted for the crankshaft parts:

Let  $d$  = Diameter of crankpin

$D$  = Diameter of main journal.

Then for overhung crankshaft.

- a) Diameter of main journal  $D = 1.25$  to  $1.5d$
- b) Length of main journal  $l = 1.25D$
- c) Length of journal inside the crank  $L_1 = 1.0$  to  $1.25D$
- d) Length of crank pin  $l = 1.0$  to  $1.25d$
- e) Length of pin inside the crank  $l_1 = 1.0$  to  $1.25d$
- f) Thickness of web  $t = 0.7$  to  $1.0d$
- g) Width of web nearer to crank pin  $a = 1.5d$
- h) Width of web nearer to journal  $b = 1.5d$

For centre crankshaft

- a) Diameter of journal  $D = d$
- b) Thickness of web  $t = 0.7d$
- c) Width of web  $w = 1.5d$

The remaining parameters may be calculated based on design stress values.

**Ex .1.**

A four stroke diesel engine has the following specifications: Brake power = 5 kW ; Speed = 1200 r.p.m. ; Indicated mean effective pressure = 0.35 N / mm<sup>2</sup> ; Mechanical efficiency = 80 % . Determine : 1. bore and length of the cylinder ;  
2. thickness of the cylinder head ; and 3. size of studs for the cylinder head.

**Solution.** Given: B.P. = 5kW = 5000 W ; N = 1200 r.p.m. or  $n = N / 2 = 600$  ;  
 $p_m = 0.35 \text{ N/mm}^2$ ;  $\eta_m = 80\% = 0.8$

**1. Bore and length of cylinder**

Let  $D$  = Bore of the cylinder in mm,  
 $A$  = Cross-sectional area of the cylinder =  $\frac{\pi}{4} D^2 \text{ mm}^2$   
 $l$  = Length of the stroke in m.  
 $= 1.5 D \text{ mm} = 1.5 D / 1000 \text{ m} \dots\dots\dots$  (Assume)

We know that the indicated power,  
 $I.P = B.P. / \eta_m = 5000 / 0.8 = 6250 \text{ W}$

We also know that the indicated power (I.P.),  
 $6250 = \frac{p_m \cdot l \cdot A \cdot n}{60} = \frac{0.35 \cdot 1.5D \cdot \frac{\pi}{4} D^2 \cdot 600}{60 \cdot 1000 \cdot 4} = 4.12 \times 10^{-3} D^3$   
...∴ For four stroke engine,  $n = N/2$

$D^3 = 6250 / 4.12 \times 10^{-3} = 1517 \times 10^3$  or  $D = 115 \text{ mm Ans.}$

and  $l = 1.5 D = 1.5 \times 115 = 172.5 \text{ mm}$

Taking a clearance on both sides of the cylinder equal to 15% of the stroke, therefore length of the cylinder,

$L = 1.15 l = 1.15 \times 172.5 = 198$  say  $200 \text{ mm Ans.}$

**2. Thickness of the cylinder head**

Since the maximum pressure ( $p$ ) in the engine cylinder is taken as 9 to 10 times the mean effective pressure ( $p_m$ ), therefore let us take

$p = 9 p_m = 9 \times 0.35 = 3.15 \text{ N/mm}^2$

We know that thickness of the cylinder head,

$t_h = D \sqrt{\frac{C \cdot p}{42}} = 115 \sqrt{\frac{0.1 \cdot 3.15}{42}} = 9.96$  say  $10 \text{ mm Ans.}$

...(Taking  $C = 0.1$  and  $\sigma_t = 42 \text{ MPa} = 42 \text{ N/mm}^2$ )

**3. Size of studs for the cylinder head**

Let  $d$  = Nominal diameter of the stud in mm,  
 $d_c$  = Core diameter of the stud in mm. It is usually taken as  $0.84 d$ .  
 $\sigma_t$  = Tensile stress for the material of the stud which is usually nickel steel.  
 $n_s$  = Number of studs.

We know that the force acting on the cylinder head (or on the studs)

$$= \frac{\pi}{4} D^2 p = \frac{\pi}{4} (115)^2 3.15 = 32\,702 \text{ N} \quad \dots(i)$$

The number of studs ( $n_s$ ) are usually taken between  $0.01 D + 4$  (i.e.  $0.01 \times 115 + 4 = 5.15$ ) and  $0.02 D + 4$  (i.e.  $0.02 \times 115 + 4 = 6.3$ ). Let us take  $n_s = 6$ .

We know that resisting force offered by all the studs

$$= n_s \frac{\pi}{4} (d_c)^2 \sigma_t = 6 \frac{\pi}{4} (0.84d)^2 65 = 216d^2 \text{ N} \quad \dots(ii)$$

From equations (i) and (ii),

$$d = 12.3 \text{ mm.}$$

## UNIT 3

### POWER TRANSMISSION SYSTEMS AND PULLEYS

When the power is to be transmitted between two co-axial shafts, connecting elements like couplings or clutches can be employed on the other hand, if the power is to be transmitted between two non-co-axial shafts but may be kept parallel or non-parallel and at some distances, we need some intermediate driving elements like belts, chains, or gears. When the co-axial shafts are connected by couplings, their speeds will not differ whereas we can reduce or increase the speed of driven shaft through these intermediate driving links. Shortly saying that the drives are the intermediate mechanism between the driving and driven shafts in order to transmit the power or energy produced in one machine to another or between two members of a machine along with the variation of shaft speeds.

The belts or ropes are used to transmit power from one shaft to another by means of pulleys which rotate at the same speed or at different speeds. The amount of power transmitted depends upon the following factors:

1. The velocity of the belt.
2. The tension under which the belt is placed on the pulleys.
3. The arc of contact between the belt and the smaller pulley.
4. The conditions under which the belt is used.

It may be noted that

- a. The shafts should be properly in line to insure uniform tension across the belt section.
- b. The pulleys should not be too close together, in order that the arc of contact on the smaller pulley may be as large as possible.
- c. The pulleys should not be so far apart as to cause the belt to weigh heavily on the shafts, thus increasing the friction load on the bearings.
- d. A long belt tends to swing from side to side, causing the belt to run out of the pulleys, which in turn develops crooked spots in the belt.
- e. The tight side of the belt should be at the bottom, so that whatever sag is present on the loose side will increase the arc of contact at the pulleys.
- f. In order to obtain good results with flat belts, the maximum distance between the shafts should not exceed 10 meters and the minimum should not be less than 3.5 times the diameter of the larger pulley

### CLASSIFICATION OF POWER TRANSMITTING DRIVES

Modern machines utilize mechanical, hydraulic, pneumatic and electrical drives. The design principles of some commonly adopted mechanical drives are discussed, i.e., the power transmitting elements may be mechanical items.

Mechanical drives may be classified based on the following conditions.

- a) According to the physical conditions of transmission they may be classified into.
  - i) Friction drives such as belt and rope drives, and
  - ii) Toothed drives such as gears and chain drives
- b) According to the method of linking the driving and driven members, they may be grouped into,
  - i) Drives with direct contact between the driving and driven members such as gears,
  - ii) Drives with an intermediate link between the driving and driven members such as belts, ropes and chain drives.
- c) According to positions of shaft axes as ,
  - i) Flexible drives: Here the slight variation of shaft axes from parallelism may be permitted because this variation will not affect much the proper function of drive and also the slight variation of centre distance may not be minded much.  
Ex: Belt drives, rope drives, chain Drives.
  - ii) Rigid drives: Here the variations of shaft axes from parallelism and centre distance will not be permitted because of the rigid construction and direct contact of the driving and driven members.
  - iii) Ex: Gear drives.

### **ELEMENTS OF A POWER DRIVE**

Each transmission mechanism comprises two essential shafts namely the driving (input) shaft and the driven (output) shaft.

The members of power suppliers, like shafts and pulleys of a motor are called as driving members and the members of power receivers like shafts and pulleys of a machine (say lathe or Rice mill) may be called as driven members.

Each drive, whether it may be a belt, chain, or gear drive, has its specific features and fields of application. The choice of drive depends on the amount of power to be transmitted, peripheral distance between the axes of the mating members.

### **BELT DRIVE:**

It is a mechanical drive in which the driving shaft and driven shaft are connected by a flexible link (i.e belt) through pulleys mounted on the shafts.

Generally, the belts and chain drives are called as flexible drives because they allow the designer considerable flexibility in location of driving and driven machineries and tolerances are not critical as in the case of gear drives. Another advantage of flexible drives, especially of belt drives, is that they reduce vibration and shock transmission.

### **SELECTION OF A BELT DRIVE**

Following are the various important factors upon which the selection of a belt drive depends:

1. Speed of the driving and driven shafts,
2. Speed reduction ratio,

- |                                 |  |
|---------------------------------|--|
| 3. Power to be transmitted,     | 4. Centre distance between the Shafts, |
| 5. Positive drive requirements, | 6. Shafts layout,                      |
| 7. Space available, and         | 8. Service conditions.                 |

## TYPES OF BELTDRIVES

The belt drives are usually classified into the following three groups:

- 1. LIGHT DRIVES.** These are used to transmit small powers at belt speeds upto about 10 m/s, as in agricultural machines and small machine tools.
- 2. MEDIUM DRIVES.** These are used to transmit medium power at belt speeds over 10 m/s but up to 22 m/s, as in machine tools.
- 3. HEAVY DRIVES.** These are used to transmit large powers at belt speeds above 22 m/s, as in compressors and generators.

## TYPES OF BELTS

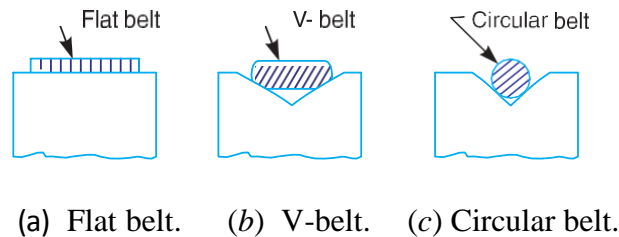

**Fig. 3.1.** Types of belts.

Though there are many types of belts used these days, yet the following are important from the subject point of view:

- 1. FLAT BELT.** The flat belt, as shown in Fig. 3.1 (a), is mostly used in the factories and workshops, where a moderate amount of power is to be transmitted, from one pulley to another when the two pulleys are not more than 8 meters apart.
- 2. V-BELT.** The V-belt, as shown in Fig. 3.1 (b), is mostly used in the factories and workshops, where a moderate amount of power is to be transmitted, from one pulley to another, when the two pulleys are very near to each other.
- 3. CIRCULAR BELT OR ROPE.** The circular belt or rope, as shown in Fig. 3.1 (c), is mostly used in the factories and workshops, where a great amount of power is to be transmitted, from one pulley to another, when the two pulleys are more than 8 meters apart.

If a huge amount of power is to be transmitted, then a single belt may not be sufficient. In such a case, wide pulleys (for V-belts or circular belts) with a number of grooves are used. Then a belt in each groove is provided to transmit the required amount of power from one pulley to another.

## MATERIAL USED FOR BELTS

The material used for belts and ropes must be strong, flexible, and durable. It must have a high coefficient of friction. The belts, according to the material used, are classified as follows:

**LEATHER BELTS.** The most important material for the belt is leather. The best leather belts are made from 1.2 meters to 1.5 meters long strips cut from either side of the back bone of the top grade steer hides. The hair side of the leather is smoother and harder than the flesh side, but the flesh side is stronger. The fibers on the hair side are perpendicular to the surface, while those on the flesh side are interwoven and parallel to the surface. Therefore for these reasons, the hair side of a belt should be in contact with the pulley surface, as shown in Fig. 3.2. This gives a more intimate contact between the belt and the pulley and places the greatest tensile strength of the belt section on the outside, where the tension is maximum as the belt passes over the pulley.

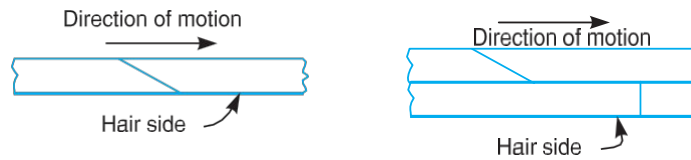

(a) Single layer belt.

(b) Double layer belt.

**Fig. 3.2.** Leather belts.

The leather may be either oak-tanned or mineral salt tanned *e.g.* chrome tanned. In order to increase the thickness of belt, the strips are cemented together. The belts are specified according to the number of layers *e.g.* single, double or triple ply and according to the thickness of hides used *e.g.* light, medium or heavy.

The leather belts must be periodically cleaned and dressed or treated with a compound or dressing containing neats foot or other suitable oils so that the belt will remain soft and flexible.

**COTTON OR FABRIC BELTS.** Most of the fabric belts are made by folding canvass or cotton duck to three or more layers (depending upon the thickness desired) and stitching together. These belts are woven also into a strip of the desired width and thickness. They are impregnated with some filler like linseed oil in order to make the belts water proof and to prevent injury to the fibers. The cotton belts are cheaper and suitable in warm climates, in damp atmospheres and in exposed positions. Since the cotton belts require little attention, therefore these belts are mostly used in farm machinery, belt conveyor etc.

**RUBBER BELT.** The rubber belts are made of layers of fabric impregnated with rubber composition and have a thin layer of rubber on the faces. These belts are very flexible but are quickly destroyed if allowed to come into contact with heat, oil or grease. One of the principal advantage of these belts is that they may be easily made endless. These belts are found suitable for saw mills, paper mills where they are exposed to moisture.

**BALATA BELTS.** These belts are similar to rubber belts except that balata gum is used in place of rubber. These belts are acid proof and water proof and it is not effected by



animal oils or alkalis. The balata belts should not be at temperatures above 40° C because at this temperature the balata begins to soften and becomes sticky. The strength of balata belts is 25 per cent higher than rubber belts.

## TYPES OF FLAT BELT DRIVES

The power from one pulley to another may be transmitted by any of the following types of belt drives:

**OPEN BELT DRIVE.** The open belt drive, as shown in Fig. 3.3, is used with shafts arranged parallel and rotating in the same direction. In this case, the driver *A* pulls the belt from one side (*i.e.* lower side *RQ*) and delivers it to the other side (*i.e.* upper side *LM*). Thus the tension in the lower side belt will be more than that in the upper side belt. The lower side belt (because of more tension) is known as **tight side** whereas the upper side belt (because of less tension) is known as **slack side**, as shown in Fig. 3.3.

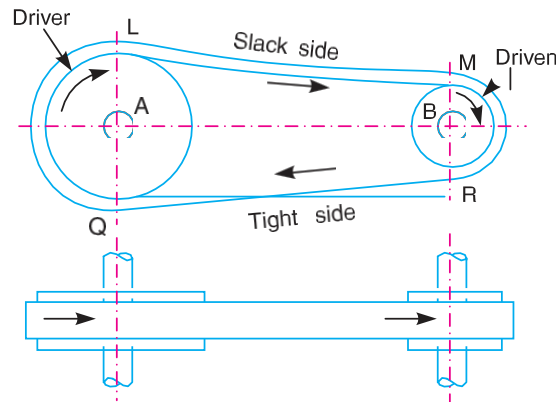

**Fig. 3.3.** Open belt drive.

**CROSSED OR TWIST BELT DRIVE.** The crossed or twist belt drive, as shown in Fig. 3.4, is used with shafts arranged parallel and rotating in the opposite directions.

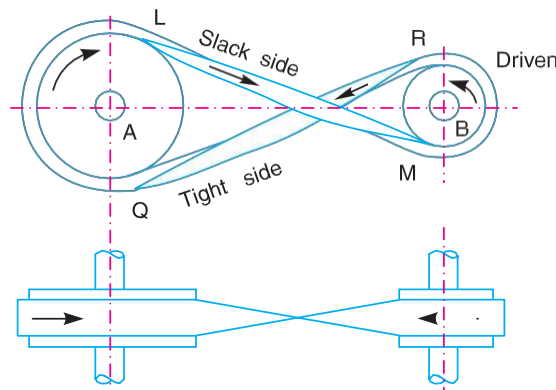

**Fig. 3.4.** Crossed or twist belt drive.

In this case, the driver pulls the belt from one side (*i.e.*  $RQ$ ) and delivers it to the other side (*i.e.*  $LM$ ). Thus the tension in the belt  $RQ$  will be more than that in the belt  $LM$ . The belt  $RQ$  (because of more tension) is known as **tight side**, whereas the belt  $LM$  (because of less tension) is known as **slack side**, as shown in Fig. 3.4.

A little consideration will show that at a point where the belt crosses, it rubs against each other and there will be excessive wear and tear. In order to avoid this, the shafts should be placed at a maximum distance of  $20b$ , where  $b$  is the width of belt and the speed of the belt should be less than 15 m/s.

**QUARTER TURN BELT DRIVE.** The quarter turn belt drive also known as right angle belt drive, as shown in Fig. 3.5 (a), is used with shafts arranged at right angles and rotating in one definite direction. In order to prevent the belt from leaving the pulley, the width of the face of the pulley should be greater or equal to  $1.4b$ , where  $b$  is the width of belt.

In case the pulleys cannot be arranged, as shown in Fig. 3.5 (a), or when the reversible motion is desired, then a **quarter turn belt drive with guide pulley**, as shown in Fig. 3.5 (b), may be used.

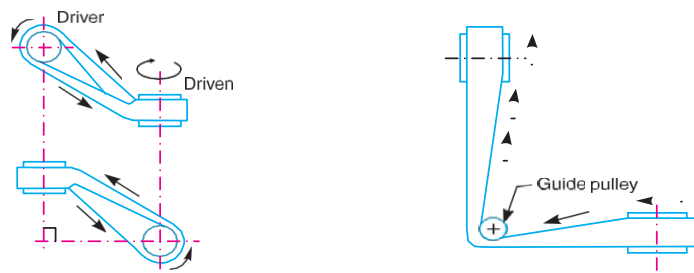

a) Quarter turn belt drive. (b) Quarter turn belt drive with guide pulley

**Fig. 3.5**

**BELT DRIVE WITH IDLER PULLEYS.** A belt drive with an idler pulley, as shown in Fig. 3.6 (a), is used with shafts arranged parallel and when an open belt drive cannot be used due to small angle of contact on the smaller pulley. This type of drive is provided to obtain high velocity ratio

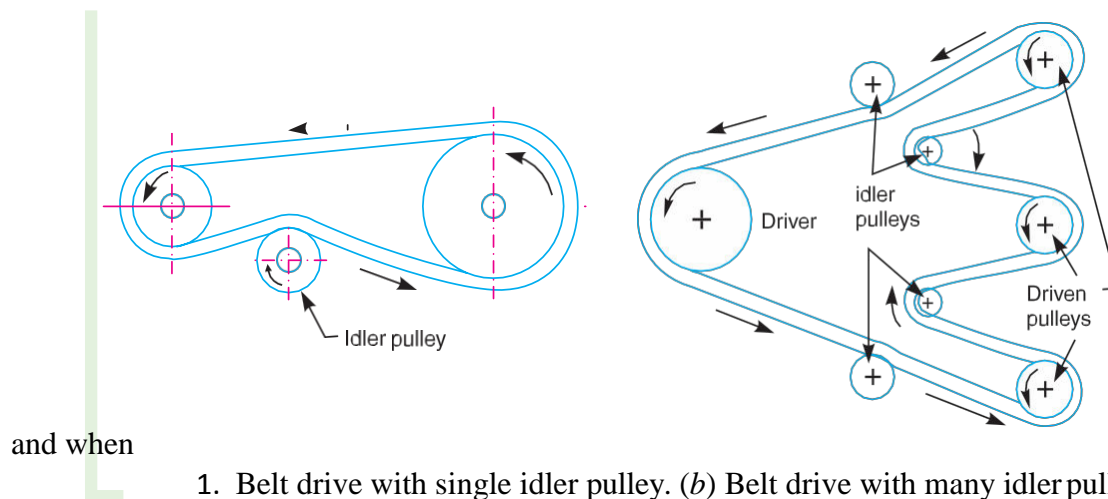

and when

1. Belt drive with single idler pulley. (b) Belt drive with many idler pulleys.

**Fig. 3.6**

the required belt tension cannot be obtained by other means.

When it is desired to transmit motion from one shaft to several shafts, all arranged in parallel, a belt drive with many idler pulleys, as shown in Fig. 3.6 (b), may be employed.

**COMPOUND BELT DRIVE.** A compound belt drive, as shown in Fig. 3.7, is used when power is transmitted from one shaft to another through a number of pulleys.

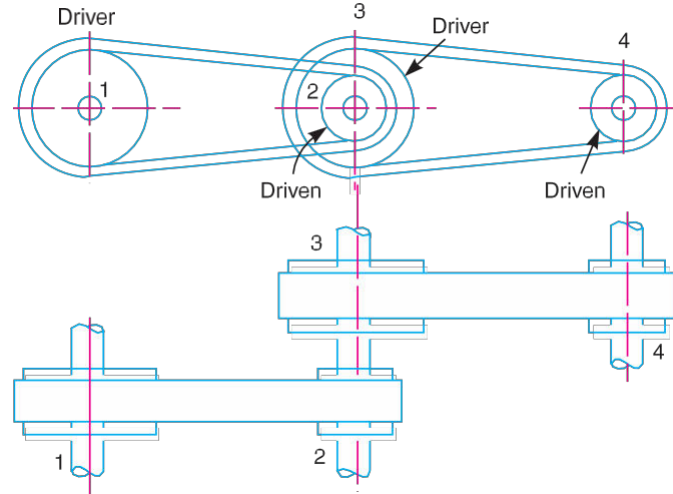

**Fig. 3.7.** Compound belt drive.

**STEPPED OR CONE PULLEY DRIVE.** A stepped or cone pulley drive, as shown in Fig. 3.8, is used for changing the speed of the driven shaft while the main or driving shaft runs at constant speed. This is accomplished by shifting the belt from one part of the steps to the other.

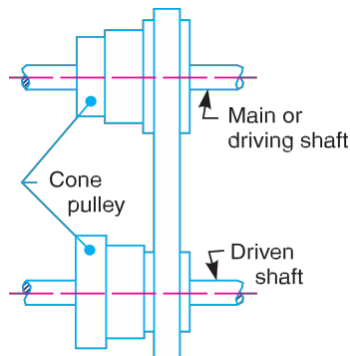

**Fig. 3.8.** Stepped or cone pulley Drive

**FAST AND LOOSE PULLEY DRIVE.** A fast and loose pulley drive, as shown in Fig. 3.9, is used when the driven or machine shaft is to be started or stopped whenever desired without interfering with the driving shaft. A pulley which is keyed to the machine shaft is called *fast pulley* and runs at the same speed as that of machine shaft. A loose pulley runs freely over the machine shaft and is incapable of transmitting any power. When the driven shaft is

required to be stopped, the belt is pushed on to the loose pulley by means of sliding bar having belt forks.

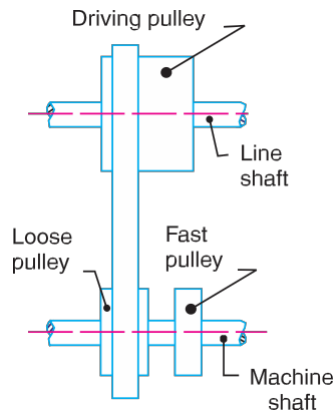

**Fig. 3.9.** Fast and loose pulley drive.

## WORKING CHARACTERISTICS OF FLAT BELTS

Flat belts are made of leather, cotton fabrics, rubber, synthetic fibres etc. Their maximum tensile strength (i.e ultimate strength) varies as follows:

1. For leather belting it varies from  $20 \text{ N/mm}^2$  to  $35 \text{ N/mm}^2$
2. For cotton or fabric belting it varies from  $35 \text{ N/mm}^2$  to  $40 \text{ N/mm}^2$

By assuming that the factor of safety as 8 to 10, the working stress may be considered from  $1.75 \text{ N/mm}^2$  to  $2.8 \text{ N/mm}^2$ , which may take the belt to have the life of about 15 years.

It has been found that for efficient transmission of power the belt speed of 17.5 m/s to 22.5 m/s may be adopted if the belt speed is increased, the centrifugal force is also increased which tries to pull the belt away from the pulley which results the decreasing of power transmitting capacity of the belt.

When discussing about the working characteristics of flat belts, some technical parameters must be familiarized. The following some of such parameters

## VELOCITY RATIO OF BELT DRIVE

The velocity ratio (speed ratio) is the ratio of the speed of the driven pulley to the speed of driver pulley.

Let  $d, n$  = Diameter and speed in r.p.m of driving pulley (usually smaller size)

$D, N$  = Diameter and speed in r.p.m of driven pulley (usually bigger size)

The distance travelled per unit time (i.e. linear velocity) is same for both pulleys. (when the belt is no slip).

$$v = \frac{\pi d n}{60} = \frac{\pi D N}{60}$$

$$d n = D N$$

The speed ratio (i.e velocity ratio) = V.R  $\frac{N}{n} = \frac{d}{D}$

Suppose the thickness of belt is to be considered, then the effective diameters are

For driving pulley  $d^I = d + (2 \times \frac{t}{2}) = d + t$  and driven pulley  $D^I = D + (2 \times \frac{t}{2}) = D + t$

Then  $i = \frac{N}{n} = \frac{d^I}{D^I} = \frac{d+t}{D+t}$

### SLIP OF THE BELT

Since the belt is to transmit power through friction, it must be given initial tension in order to hold the pulley with sufficient grip. Due to age or centrifugal tension caused on the belt, the grip may be slightly lost. Hence, because of less grip, during starting, the driving pulley alone rotates slightly without pulling the belt or the belt alone moves without rotating driven pulley. This type of difference of motions between the pulley and belt is termed as belt slip. The main drawback of the slip is that it will reduce the velocity ratio.

Let  $S_1 = \% \text{ of slip between driving pulley and belt} = \left( \frac{v_1 - v_s}{v_1} \right)$

$S_2 = \% \text{ of slip between driven pulley and belt} = \left( \frac{v_b - v_2}{v_b} \right)$

Then total slip  $S = S_1 + S_2$

The velocity ratio  $i = \frac{N}{n} = \frac{d}{D} \left( 1 - \frac{S}{100} \right)$ ..... when t is neglected

Or  $i = \frac{N}{n} = \frac{d+t}{D+t} \left( 1 - \frac{S}{100} \right)$ ..... when t is considered, where **t** =belt thickness.

### CREEP OF BELT

When the belt passes from slack side to the tight side, a certain of the belt extends and it contracts again when the belt passes from the tight side to the slack side. Due to these changes of length, there is a relative motion between the belt and the pulley surfaces. This relative motion is termed as creep. The total effect of creep is reduce slightly the speed of the driven pulley or follower. Considering creep, velocity ratio is given by



$$i = \frac{N}{n} = \frac{d}{D} \left( \frac{E + \sqrt{\sigma_2}}{E + \sqrt{\sigma_1}} \right)$$

where  $\sigma_1$  &  $\sigma_2$  = stress in the belt on the tight and slack side respectively

E = young's modulus for the material of the belt

Note: since the effect of creep is very small, therefore it is generally neglected.

### CENTRIFUGAL TENSION

When the belt runs at lower speed, the initial tension given to the belt will be sufficient to keep the belt on the pulley with required grip, on the other hand, if the belt speed increases, due to centrifugal action, the belt will try to fly off from the pulley. At the same time, the tensions at the tight side and slack side will increase. The force applied on the shaft due to centrifugal action is called as centrifugal tension.

Let  $T_1$  = Tension in the tight

side  $T_2$  = Tension in the slack

side

$T_c$  = centrifugal tension =  $mv^2$

It is known that, the total tensions at tight side and slack side are given by

$$T_{t1} = T_1 + T_c \quad \text{and} \quad T_{t2} = T_2 + T_c$$

Since the centrifugal tension depends on the belt velocity, at low speeds the centrifugal action and its tension may be neglected. But for the higher speeds, the centrifugal tension will be taken into account.

i.e  $T_{t1} = T_1$  and  $T_{t2} = T_2$  at low speeds, and  $T_{t1} = T_1 + T_c$  and  $T_{t2} = T_2 + T_c$  high speeds.

Also since the centrifugal force tries to pull the belt away from the pulley resulting the decrease of power transmitting capacity, the linear velocity of the belt is limited to 17.5 to 22.5 m/s, in order to control the centrifugal tension.

If  $\mu$  is the coefficient of friction between the belt and pulley and  $\theta$  is the angle of contact for driving pulley in radians, then it is found that the ratio of driving tensions is

$$\frac{T_1}{T_2} = e^{\mu\theta} \dots\dots\dots \text{when the centrifugal tension } (T_c) \text{ is neglected.}$$

$$(T_1 - T_c) / (T_2 - T_c) = e^{\mu\theta} \dots\dots\dots \text{when the centrifugal tension } (T_c) \text{ is considered.}$$

### LAW OF BELTING

Law of belting states that the centre line of the belt, as it approaches the pulley must lie in a plane perpendicular to the axis of that pulley, otherwise the belt will run off the pulley.





## DESIGN OF FLAT BELTS

Flat Belt Drives

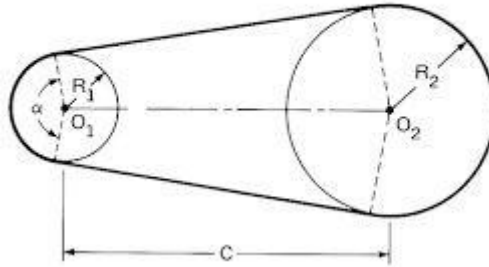

The essential parameters of flat belt like width, thickness, length and the type of belt are determined based on two methods.

1. Using fundamental formulas
2. Using manufacturer's catalogues

### USING FUNDAMENTAL FORMULAS

When the driving pulley rotates the driven pulley by belt, the belt pulling side is known as tight side and the belt releasing side is known as slack side. If the centre distance and the selected materials of belt and pulleys are kept proper, the belts can have sufficient grip over the pulley without any slip and the power transmission is properly maintained.

For designing the belt based on fundamental formulae, we should know the tensions (i.e loads) on tight side and slack side of the pulleys, power-torque relationship, coefficient of friction between the contact surfaces of pulleys and belt, diameters of pulleys and so on. Some of such useful formulas are

1. Power transmitted by belt

$$P = (T_1 - T_2) v \dots \dots \text{N-m/s}$$

Where  $T_1$  = Tensions in the tight side in Newton's  
 $T_2$  = Tensions in the slack side in Newton's  
 $V$  = velocity of belt in m/s

2. Velocity of belt (v)  $\frac{\pi dn}{60000}$  m/s

Where  $d$  = Diameter of smaller pulley in mm  
 $n$  = speed of smaller pulley in r.p.m

3. Ratio between the tensions of tight and slack side



$$\frac{T_1}{T_2} = e^{\mu\theta}$$

Where,

$\mu$  = coefficient of friction between the contact surfaces of pulley and belt

$\theta$  = Arc of contact in radians

4. The relationships used to find out the length and arc of contact are common with manufacturer's catalogue.

## USING MANUFACTURER'S CATALOGUES

In this method, the manufacturers are producing certain types of belts whose widths and thickness have already been standardized by them. Their loading capacity (I.e belt rating) are also experimentally determined by the concerned manufacturers. They may also adopt certain safety factors like service factors, angle of contact factors for obtaining better design. To meet our requirement, we may select a particular belt based on working conditions and it is compared with their available data in practice.

**Design of belts by this method is based mainly on two concepts:**

1. How much power (i.e maximum power (or) Design power) to be transmitted.
2. What may be the power transmitting capacity(i.e belt rating)of the selected belt.

For determining the design power and belt rating, we must consider certain correction factors like service factors, arc of contact factors and so on. Some of the factors and data adopted by manufacturers are given in the jalal data book page 23.7.

### I) Arc of contact

Consider the driving pulley and the driven pulley are connected by a flat belt as shown above. The angle subtended by the overlaying belt on the pulley is known as angle of contact or arc of contact ( $\theta$ ).

Let  $d$  = Diameter of smaller pulley (driver)  
 $D$  = Diameter of bigger pulley(driven)  $C$  = centre distance between pulleys

Then Arc of contact factor ( $\theta$ ) for smaller pulley

For

- i) Open belt drive  $\theta = 180^\circ - \left(\frac{D-d}{C}\right) 60^\circ$
- ii) Cross belt drive  $\theta = 180^\circ + \left(\frac{D+d}{C}\right) 60^\circ$
- iii) Quarter turn belt drive  $\theta = 180^\circ - \left(\frac{D-d}{C}\right) 60^\circ$

### II) Load rating (or) Belt capacity



The load rating have been developed for 1800 of arc of contact, 10 m/s belt speed per mm width, and per ply and they are to be corrected for actual arc of contact, actual speed, actual plies and through these data the required width is determined.

Load rating per mm width per ply at 1800 arc of contact at 10 m/s belt speed:

‘HI SPEED’ 878 g duck belting: 0.023kw (or) 0.0314 h.p

‘FORT’ 949 g duck belting: 0.0289 kw (or) 0.0392 h.p

**III) Length of belt(L)**

$$\text{Open belt drive } L = 2C + \frac{\pi}{2} (D + d) + \frac{(D-d)^2}{4C}$$

$$\text{Cross belt drive } L = 2C + \frac{\pi}{2} (D + d) + \frac{(D+d)^2}{4C}$$

$$\text{Quarter turn belt drive } L = 2C + \frac{\pi}{2} (D + d) + \frac{D^2+d^2}{2C}$$

- iv) Belt tensions: If the length of belt, determined by using the above relations is used as it is, then the belt will not transmit the power properly due to slip of belts (or) insufficient grip and hence certain amount of length should be reduced from the above calculated length to overcome the above deficiency. The reduction of length is based on the type of plies.

For,

1. Belt of 3 plies ..... 1.5 % of L
2. Belt of 4,5 &6 plies ..... 1 % of L
3. Belt of 8 plies ..... 0.5 % of L

Should be reduced in order to get belt tensions.

- v) Pulley widths:

Generally the pulleys should be slightly wider than belt widths.pulleys width table is given in jalal data book 23.9.

**DESIGN PROCEDURE FOR FLAT BELT BASED ON MANUFACTURER’S TABLES**

1. From the given conditions like power, type of working conditions, diameter of pulleys, speed ratio etc, determine maximum power(i.e design power) as

Design power = Rated power (i.e given power) x service factor(i.e load correction factor)  
x Arc of contact factor.



Select service factor based on nature of load and applications (jalal data book page 23.7 and table 23.6) and choose arc of contact factor based on contact of the belt on the smaller pulley jalal data book 23.7.

2. Decide the type of belt (i.e number of plies of the belt) depending upon the belt speed and diameter of smaller pulley, JBD -23.8
3. Then calculate the belt rating (i.e power transmitting capacity per mm width) for the above said belt using corresponding relations.
4. Find the required width by dividing the design power by belt capacity, and adopt the next standard available width.
5. Determine the length of belt based on type of drive and then reduce certain amount of length so as to get initial tension (i.e to make the belt to hold the pulley firmly for getting proper grip).
6. Find out pulley dimensions and draw the arrangement of belt drive.

Note: if calculated width is not available in the manufacturer's table, hen higher capacity belt (i.e belt of higher ply) may be selected.

### **FLAT BELT PULLEYS:**

The flat belt pulley is a cylindrical member, similar to fly wheel in which thickness is small and width is large as compared to flywheel. The flat belt is laid on the pulley and the power is transmitted from the driving shaft to driven shaft by the belt drive set up. Similar to flywheel, pulleys are also made into i) solid or web type and ii) Rim and hub type models. If the size of the pulley is to be very large, it is made into spitted rim model. The rim type pulley is shown below.

### **MATERIALS FOR PULLEY**

The material for making pulley depends on the size and velocity of pulley, working environments etc. The commonly used pulley materials are i) cast-iron ii) steel iii) wood and iv) compressed papers etc.

### **DESIGN OF CAST-IRON PULLEYS FOR FLAT BELT DRIVE**

In a belt drive, since the speed or velocity ratio is the inverse ratio of the diameters of driving and driven pulleys, selection of pulley diameters must be proper to have the required velocity ratio. Also since the pulley resembles with flywheels the design of pulley is very similar to flywheel design. The parameters of the main parts of pulley such as pulley rim, hub and arm are determined as follows.





## DIMENSIONS OF PULLEY RIM

- i) Pulley diameter:
- ii) The rim diameter (i.e pulley outer diameter) can be determined from the velocity ratio and centrifugal force. Due to centrifugal force acting on the rim, the rim has the tendency to expand which is restrained by the arms. The tensile stress induced in the arm due to centrifugal force is given by

$$\sigma_t = S_t = \rho v^2$$

where  $\rho$  = Density of rim material in kg/m<sup>3</sup> = 7200 kg/m<sup>3</sup> for cast iron

v = Linear velocity of rim in m/s

$$= \frac{\pi DN}{60} \quad \text{where } D = \text{Diameter of pulley in m}$$

N = speed of pulley in r.p.m

The diameter obtained from the above relation can be standardized from the dimensions given in jalal data book 23.13 table in 23.9 page.

- iii) Rim width(B)  
The width of rim is decided by the width of belt. If the belt is known, the rim width (i.e pulley width) is given some extra dimension as represented in table 23.11 jalal data book 23.9 page. for safe operation. Some standard dimensions for pulley width have been presented in table 23.12 in JBD 23.9
- iv) Rim thickness  
The thickness of pulley rim may approximately be taken as

$$t = \frac{D}{200} + 3 \text{ mm (single belt)}$$

$$t = \frac{D}{200} + 6 \text{ mm (double belt)}$$

where D = Diameter of pulley in mm.

- v) Crown thickness(h)  
Pulley is provided a slight conical shape or convex shape in its rim's outer surface in order to prevent the belt from running off the pulley due to centrifugal force. This is known as crowning of pulley. Usually the crowning height (i.e crown thickness) may be of 1/96 of pulley face width. The standard values of crown thickness are given in table 23.13 & 23.15 in jalal data book page 23.9 & 23.10.

## DIMENSIONS OF ARM



### 1) Number of arms

The number of arms may be taken as

N = 4 for pulley diameters upto 450 mm

N = 6 for pulley diameters over 450 mm.

When the pulley diameter is less than 200 mm, the pulley is usually made with solid disc (i.e web type) instead of providing arms.

### 3. Cross-section of arms

Cross section of arm is usually elliptical with major axis(x) equal to twice the major axis(y). The cross-section dimensions of the arm are determined by treating the arm as a cantilever which is assumed to be fixed at the hub end and carrying a concentrated load at the rim end. The length of cantilever is taken equal to the radius of pulley. Also it is assumed that at any given time, the power is transmitted from the hub to rim to hub through only half the total number of arms.

Let T – Torque transmitted

R = Radius of

pulley N= Number

of arms

The tangential force acting on one arm at the rim end due to torque is given by

$$W \text{ or } F = \frac{2T}{nR}$$

Bending moment applied at the hub end due to the tangential force,

$$M = F \times R = \frac{2T}{nR} \times R = \frac{2T}{n}$$

Section modulus for the arm is  $Z = \frac{\pi}{32} x^2 y$

The induced bending stress  $S_b = \frac{M}{Z} = \frac{2T}{nZ}$

By equating this induced stress with the allowable bending stress, the dimensions of arm x and y can be determined. The allowable bending stress for cast-iron material is taken as 16 to 20 N/mm<sup>2</sup>.

The arms are tapered from hub to rim. The tapers usually 1/48 to 1/32.

#### Dimensions of hub:

Let  $d_s$  = Diameter of shaft

$D_i$  = Inner diameter of hub

$D_o$  = outer diameter of hub

L = length of hub

Then,

$D_i = d_s$  and  $d_o = 1.5 d_s + 25 \text{ mm}$  but not more than  $2d_s$

$L = (2/3 \text{ to } 1)B$ , where B is the width of pulley.



Note: The maximum speed of cast iron pulley is taken as follows

- a) For solid pulley with flat or crown face:1500 m/min
- b) For split pulley with flat or crown face :1000 m/min

## V-BELT DRIVES

v-belts are another type of flexible connectors for transmitting power from one pulley to another whose centre distances are approximately up to 3 meters. Their cross-section is trapezoidal or similar to a wedge. Generally v-belts are made endless (i.e each belt is made in a circular form) with various cross-section which may be differentiated by various grades. The belts are adopted on grooved pulley, grooves being v-shaped or having two inclined sides with flat bottom. The contact between the belts & pulleys is obtained in the inclined surfaces of pulleys in contrast with flat belt where contact is obtained at the top surface of the pulley.

A Properly installed should v-belt should fit tightly against the sides of the pulley grooves without projecting beyond the rim or touching the bottom of the groove. The correct method of mounting a wedge -shaped belt in a grooved pulley is shown in fig below. In any grade belt, the included angle between the inclined surfaces is about  $40^{\circ}$ .

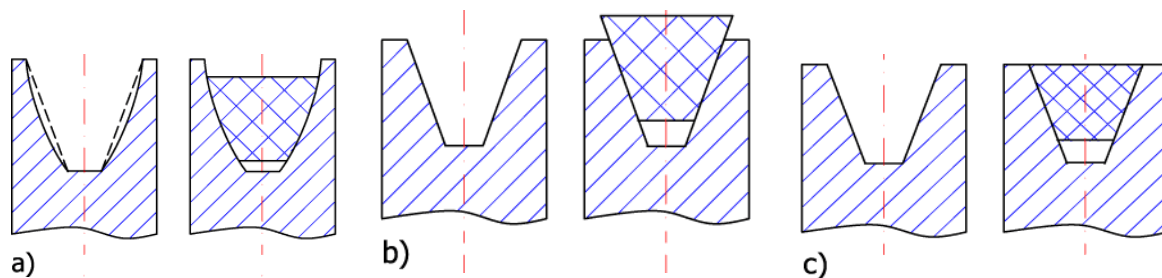

Comparing to flat belt ; v-belt is adopted for positive drive (i.e drive without slip).

## MATERIALS USED

Usually V-belts are made of cord and fabric, impregnated with rubber, the cord material being cotton or rayon.

## Types of V-belts

Generally v-belts are classified into various grades based on their power transmitting capacity as A,B,C,D and E. The cross-sectional areas are in increasing order from A to E.



Depending upon the places of applications, v-belts are manufactured into single v-belts, multiple v-belts and ribbed belts.

The multiple v-belt and ribbed belt are manufactured in such away that they may have a number of separate single v-belts joined together to act as a single unit, for transmitting very high power, a calculated number of single v-belts or a suitable multiple v-belt drive, all the belts should be stretched at the same rate.(i.e drive with many number of single v-belts). Then only we can say that the load or (power) is distributed evenly between the belts. If any one belt is worn-out, all the belts should be replaced by new belts instead of changing the broken belt alone so as to have the even distribution of load and constant velocity of all belts. such a deficiency may be avoided in the case of multiple v-belt. Drive for getting clear positive drive, toothed or timing belt is generally preferred.

#### Advantages and Disadvantages of V-belt Drive over Flat Belt Drive

Following are the advantages and disadvantages of the V-belt drive over flat belt drive.

#### **ADVANTAGES**

1. The V-belt drive gives compactness due to the small distance between the centers of pulleys.
2. The drive is positive, because the slip between the belt and the pulley groove is negligible.
3. Since the V-belts are made endless and there is no joint trouble, therefore the drive is smooth.
4. It provides longer life, 3 to 5 years.
5. It can be easily installed and removed.
6. The operation of the belt and pulley is quiet.
7. The belts have the ability to cushion the shock when machines are started.
8. The high velocity ratio (maximum 10) may be obtained.
9. The wedging action of the belt in the groove gives high value of limiting ratio of tensions. Therefore the power transmitted by V-belts is more than flat belts for the same coefficient of friction, arc of contact and allowable tension in the belts.
10. The V-belt may be operated in either direction with tight side of the belt at the top or bottom. The centre line may be horizontal, vertical or inclined.

#### **DISADVANTAGES**





1. The V-belt drive cannot be used with large centre distances.
2. The V-belts are not as durable as flat belts.
3. The construction of pulleys for V-belts is more complicated than pulleys for flat belts.
4. Since the V-belts are subjected to certain amount of creep, therefore these are not suitable for constant speed application such as synchronous machines, and timing devices.
5. The belt life is greatly influenced with temperature changes, improper belt tension and mismatching of belt lengths.
6. The centrifugal tension prevents the use of V-belts at speeds below 5 m/s and above 50m/s.

### DESIGN OF V-BELTS USING BASIC FORMULAS

Similar to flat belts, v-belts are also designed based on i) fundamental formulas and ii) manufacturers catalogues. Since v-belts vary considerably in cross-section and amount of reinforcement, the design of v-belts is usually based on the tables given by the manufacturers than the first method (i.e using fundamental formulas) anyhow, before learning in detail about the design using manufacturers tables, it is better to have some basic ideas about the design using fundamental formulas.

1. Ratio of driving tensions

$$\frac{T_1}{T_2} = e^{\mu\theta / \sin(\frac{\alpha}{2})}$$

Where T1 and T2 are tensions at tight and slack side respectively

$\theta$  = Angle of contact in radians

$\alpha$  = Angle subtended by sides of v-belts

Power transmitted by a belt in S.I or M.K.S unit as

$$P = (T_1 - T_2) v \dots \dots \text{N-m/s}$$

Where  $T_1$  = Tensions in the tight side in

Newton's

$T_2$  = Tensions in the slack side in Newton's

V = velocity of belt in m/s

### DESIGN OF V-BELTS USING MANUFACTURER'S TABLE

The manufacturers produce v-belts in different grades as A, B, C, D, e which can be used to transmit different ranges of power, the range being in increasing order from A to E because of increasing order of area of cross-section in the same series.



One important point is that when selecting flat belt, we should give preference to thin wider belt for optimum power transmission because the area of contact between belt and pulley is more in thin wider belt than thick narrow belt. But in the case of v-belt, thick belt is more preferred to thin belt which may reduce the total number of belts to be operated for transmitting a particular quantity of power.

Here also, the design of v-belt depends on two concepts

1. Design power (i.e Total power after considering safety factors or correction factors)
2. Belt rating (i.e power transmitting capacity of one belt)

Consider a v-belt drive as shown in fig below

Required to transmit the power of P from one pulley of diameter d to another pulley of diameter D the pulleys being situated at a distance of C. The work may be intermittent or continuous.

**For designing such a belt we may follow certain steps.**

1. At first based on amount of power to be transmitted select the type of belt from A to E grades JBD page 24.3, table 24.1
2. Calculate design power using the relation as

$$\text{Design power} = \frac{\text{rated power} \times \text{service factor}}{\text{Arc of contact factor} \times \text{belt pitch length factor}}$$

For obtaining the above correction factors, find out the service conditions, arc of contact and pitch length and then choose suitable factors from page 24.3 tables JBD 24.2,24.3,24.4 respectively. Since the v-belt can be operated as open belt type we can make use of the following formula for finding pitch length and arc of contact. i.e The pitch length

$$L = 2C + \frac{\pi}{2} (D + d) + \frac{(D-d)^2}{4C}$$

$$\text{Arc of contact} = \theta = 180^\circ - \left( \frac{D-d}{C} \right) 60^\circ$$

3. Note the inside length corresponding to pitch length from table 24.4 for belt specifications.
4. Determine the belt rating (i.e power transmitting capacity of one belt) using suitable formula adopted by the manufacturers given in table 24.5 or 24.6 to 24.10.



5. Obtain number of belts required to transmit the entire design power as number of belts  $= \frac{\text{Design power}}{\text{BeSt rating}}$
6. Correct the centre distance according to the selected pitch length using formulas (A) which have been given below of table 24.11 and give initial tension to belt. (Refer condition B, below of table 24.11)
7. Also determine parameters of v-groove pulleys using table 24.12.

### **DESIGN OF V-GROOVED PULLEY**

The pulley required for v-belt drive must have sufficient number of v-grooves in its outer surface in order to fit the v-belts in the correct position. Mostly cast-iron or steel are adopted as the materials for v-belt pulley.

The dimensions of the v-groove of the pulley is decided by the dimensions of the v-belt. The width of pulley depends on the number of belts laid on the pulley. The diameter of pulley is found out from the linear velocity of the belt and the velocity ratio. The number of arms, their cross-sections and hub dimensions are determined similar to flat belt pulley. Some standard values for various parameters of v-groove are given in table 24.12.

$$\text{Arc of contact angle} = 2 \cos^{-1} \frac{D-d}{2C} = 180^\circ - 60^\circ \frac{D-d}{2C}$$

D = pitch dia of larger pulley, d = pitch dia of smaller pulley, C = centre distance

### **CHAIN DRIVES**

A chain drive is a mechanical device which belongs to the category of drives with intermediate link is obtained by chains. It may also be considered to be intermediate between belt and gear drives, in that it has features in common with both.

Chains are suitable for long as well as short centre distance drives and give a more compact drive than is possible with belt.



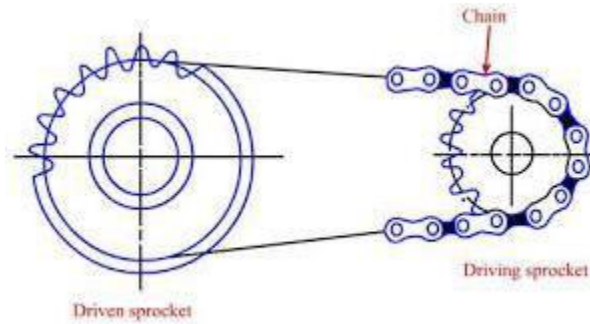

## APPLICATION

Modern chain drives are employed in these places where we require velocity ratios upto 10, chain velocities upto 20 m/s and power ratios upto 150 kW.

Chain drives are quite extensively used in transportation machineries like motor cycles, bicycles, automobiles and conveyors. And technological machines like agricultural machinery, oil well drilling rigs, machine tools.

## ADVANTAGES

1. The chain drives are having more power transmitting capacities compared with belt drives when the centre distance between the shafts is large (i.e. 5 to 8 meters).
2. Their efficiency is higher (85 %)
3. Their small size compared with V-belt for particular power transmission provides a compact set up.
4. The chain drives exert less load on the shaft since no initial tension is required as compared with belt drives.
5. They can be operated for wide range of centre distances of power transmitting sprockets.
6. One chain can be operated to transmit power to several numbers of sprockets.
7. Maintenance is very easy because the chains can easily be repaired or replaced.

## **DISADVANTAGES**

1. Design of chain drive is more complicated.
2. The operation of chain drive is noisy.
3. Their production cost is high.
4. They need careful maintenance by providing housing to the chains to save them from dirt.
5. They require more accurate assembly of shafts than belt drives.

## **CLASSIFICATION**

1. **POWER TRANSMITTING CHAINS**  
Treated for transmitting mechanical energy from one shaft to another.
2. **HAULING CHAINS**  
Used for carrying loads in conveying machinery.
3. **LOADING OF LIFTING CHAINS**  
Served for suspending, hoisting and lowering loads, mainly in material handling machineries.

## **CLASSIFICATION OF POWER TRANSMITTING CHAINS**

- a. **BASED ON THE TYPES OF CHAINS EMPLOYED**
  1. Roller chain
  2. Bush chain
  3. Silent chain
- b. **BASED ON THE NO OF CHAINS REQUIRED**
  1. Single row chain
  2. Multi row chain
- c. **BASED ON THE NO OF DRIVEN SPROCKETS**
  1. Normal type drive (i.e. one driven sprocket)
  2. Special type drive(i.e. several driven sprocket)

## **COMPONENTS OF CHAIN DRIVE**

The essential components of a chain drive area) chains b) sprockets c) chain housing and d) slack adjusters.

### **a) CHAINS:**

The chain is main element of drive which determine its reliability and service life. A





Chain consists of rigid links which are hinged together to provide flexibility for wrapping action around the driving and driven wheels. The wheels having surfaces which are shaped to conform to the type of chain used are called sprockets. The design dimensions and mechanical characteristics of chains are standardized. The strength of chain is determined by its ultimate strength established by the manufacturer's. The schematic diagram for various types of chains are show.

Regarding the design parameters, the pitch ( $p$ ) which is linear distance between the centers of consecutive rollers and the width ( $b$ ) which is the space between the inner link plates, are considered as the main geometrical characteristics of chains.

Usually the driving chains such as roller, bush and silent chains are made in various standards. Among them, the simplex, duplex and triplex chains are commonly used. Sometimes chains of four ,five and six rows are made.

A roller chain consists of alternate inner and outer links connected by hinged joints. Each joint comprises a pin of diameter ( $d_p$ ) pressed into the outer plates and bush secured in the holes of the inner plates. Roller safeguards the sprocket's teeth against wear. The diametral area or projection area of the connect surface for such a joint is given by

$$A = D_p \cdot b$$

Where  $b$  is the width of inner link plates.

## **BUSH CHAINS**

Bush chains differ from roller ones in that they have no rollers. Such a chain, is lighter in weight, but the absence of rollers intensifies the wear of teeth on the sprocket's due to sliding friction between the teeth and bushes.

When heavy loads are to be transmitted, chains with a larger pitch may be employed. In this case the sprockets have larger diameters. To diminish their diameters and reducing chain pitch values, use of multi-row chains.

A silent chain consists of a series of toothed plates pinned together in rows across the width of the chain. The structure of silent chains are more intricate, more expensive and require a good maintenance.

The materials used for making different elements of chain are as follows, plates are made of cold-rolled band of medium carbon or alloy steels. Bent plates are made of alloy steels. The parts of chain-pins, bushings and inserts are made of carburizing steels and are hardened to 50 – 65 RC. The life of chains can be prolonged by chroming the chain joints.

### **b) SPROCKETS:**

The operating capacity of a chain drive largely depends on the quality of the sprockets. The sprockets are made of cast-iron or hardened steel. The teeth of a sprocket are shaped depending on the type of chain .The small size sprocket is known as pinion-sprocket and the big size sprocket is known as wheel sprocket.

$$\alpha = \frac{360}{Z}$$

$$d = \text{pitch circle dia of sprocket} = \frac{P}{\sin(\frac{\alpha}{2})}$$

### c) CHAIN HOUSING

The housing is a cover made of thin plates and it protects the drive from dust and dirt, preserves grease and damps the noise of the drive. The housing should be as small as possible but should not interfere with adjustment of the distance between the shafts when the chain becomes stretched.

### d) SLACK ADJUSTERS:

Chain sag is regulated and the required tensions are ensured by means of movable bearings known as slack adjusters. The movable bearings are in the form of slides in which sprocket shaft is installed.

## FAILURES OF CHAIN DRIVES

The chain drive may fail due to the following causes

1. Wear in the joints leading to elongation of the chain and its faulty engagement with the sprockets. The allowable elongation is 1.5 to 2.5% .
2. Wear of the sprocket teeth.
3. Turning of pins and bushing in the plates where they are press fitted is a frequently encountered reason for the failure of roller chains.
4. Fatigue failure of the plates at the eyes.
5. Chipping and breaking of the rollers.
6. Poor lubrication and improper maintenance.

## DESIGN OF DRIVING CHAINS

Similar to belts the driving chains or power transmitting chains are designated in different ways by different concerns.

As per Indian standard (IS 2403 – 1964), roller chains are designated by the roller diameter and number of stands. For example 10.0S IS: 2403 -1964 stands for single stand (simplex) chain of 10.16 mm roller diameter. Similarly **12.0 D** IS: 2403 -1964 stands for double stand (duplex) chain of 11.90 mm roller diameter.

According to International standard organization (ISO) chains are designated by their roller dia followed by the type of chain and the number of stands. For example 10A -1 represents the chain of 10.16 mm, roller diameter and a type single stand (simplex) chain. Similarly 10A -2 is the double stand (duplex) of above category and so on.

According to roller chain manufacturers, chains are designated by the number of stands followed by the chain numbers. For example, R50, DR50 and TR50 are simplex, duplex



and Triplex types of roller chains whose chain number is 50. Similarly B35, DB35 and TB35 are simple, duplex and triplex types of bush chains whose chain number is 35.

## DESIGN CRITERIA OF CHAIN DRIVES

The chain drives can be employed to transmit from a fraction of kilowatt to 3500 kw, but in most cases up to 100 kw. When selecting a suitable chain to transmit the design power, one should consider the characteristics of certain parameters which are essential in the design point of view. The following are some of such parameters:

### 1. Chain velocity

The velocity of chain and the speed of rotation of sprockets are limited by chain wear which may increase with velocity. Hence the optimum chain velocity may be taken about 15 m/s. For high speed drives with high quality chains and proper lubrication, the velocity may be adopted up to 30 m/s.

The average velocity of chain ( $v$ ) is given by

$$v = \frac{Znp}{60000} \text{ m/s or } v = \frac{\pi dn}{60000} \text{ m/s}$$

where  $Z$  = Number of teeth of a sprocket

$n$  = sprocket speed in rpm

$p$  = Pitch of chain in mm

$d$  = pitch circle diameter of sprocket

The speed of rotation of the sprockets is limited by the impact stresses of the chain on the sprockets.

### 2. Speed ratio:

The speed ratio is decided by the allowable overall size of the drive, angle of contact (arc of meshing the chain on the smaller sprocket) and the number of teeth. Usually the speed ratio may take up to 10. It is found out from the condition of equality of average velocities of the chain on the sprockets as

$$Z_1 n_1 p = Z_2 n_2 p \text{ (since chain pitch is constant)}$$

$$\text{Speed ratio, } i = \frac{n_1}{n_2} = \frac{Z_2}{Z_1}$$

Where  $n_1, z_1$  = speed & number of teeth of small sprocket (i.e pinion sprocket)

$N_2, z_2$  = speed & number of teeth of big sprocket (i.e wheel sprocket)

### 3. Number of teeth of sprockets:

The number of teeth of sprockets is limited by the wear of chain joints, dynamic (impact)



Loads and also the noise made by the drive. The less the number of teeth, the greater the wear of the chain because the angle of chain engagement with sprocket is  $(\frac{360}{Z})$  and hence more impact load on less numbered teeth sprocket. The minimum number of teeth on sprockets in power drives with roller chains is  $Z_{min} = 19$  to 23 for speeds, 17 to 19 medium speeds and 13 to 15 for low speeds.

Due to chain wear, the chain may elongate and hence it may shift outward upon the sprocket teeth profiles. The smaller the angular pitch of the sprocket (angle between adjacent teeth) the greater the outward shift. This outward shift limits the maximum number of teeth on sprocket, which for roller chain is taken from 100 to 120.

#### **4. Distance between the sprocket axes:**

The minimum centre distance (i.e distance between the axes of sprockets) is determined from the condition that the angle of contact of the chain with the small sprocket should be at least 120° usually the centre distance may be specified in terms of pitches.

The optimum centre distance is given by

$$A = (30 \text{ to } 50) p \text{ where } p = \text{chain pitch and the maximum centre distance is } a_{max} \leq 80p .$$

#### **5. Chain pitch:**

This is the principal parameter of chain drive. Chains with larger pitch have a higher “load carrying capacity” but allow considerably low speed of rotation and operate with higher dynamic loads and noise. Usually a chain with the minimum allowable pitch may be selected for the given load, the pitch value may be selected as  $\frac{a}{80} \leq p \leq \frac{a}{25}$  where “a” is the centre distance.

#### **6. Arrangement of chain drives:**

Chain drives are arranged so that the chain travels in a vertical plane, the relative height position of the driving and driven sprockets being arbitrary. The optimum position of the line of centers is horizontal or inclined at an angle up to 45° to the horizontal. Vertical arrangement of the chain drive requires more careful adjustment of the chain tension because the sagging of the chain in this case does not provide for self-tensioning.

### **SELECTION OF CHAINS- INFLUENCING FACTORS**

In accordance with the principal criterion of chain drive performance-wear resistance of chain joints, the load carrying capacity of a chain can be determined from the condition that the pressure developed in the joints must not exceed the allowable value.

Usually chains are manufactured in different sizes with different structures such as simplex, duplex, and triplex chains and so on. Each chain is having a criterion amount of load carrying capacity. Among these various chains, for transmitting the given power, a suitable

Chain is selected based on its minimum breaking strength required and the induced stress on the bearing area of the selected chain. To overcome the chain failure, the selected chain should have more strength than the breaking load and the induced stress should be less than the allowable value.

Similar to belt drives, manufacturers formulated a certain method to select a suitable chain base on experimental data which are given in the following tables.

Let P = Power to be transmitted in watts

Q = Breaking load required for the chain in

Newton's V = chain velocity in m/s

Kn = Factor of

safety Ks = service  
factor

$\sigma$  = Allowable bearing stress in

N/mm<sup>2</sup> A = projected bearing area in

N/mm<sup>2</sup>

The power, that can transmitted (i.e safe power) on the basis of breaking load is given by

$$P = \frac{Qv}{k_n k_s} \text{ watts}$$

On the basis of allowable bearing stress, the power to be transmitted is given by

$$P = \frac{\sigma A v}{k_s} \text{ watts}$$

The required service factor (ks) may be determined based on various working conditions, such that

$$K_s = K_1.K_2.K_3.K_4.K_5.K_6$$

Where K1 = load factor

K2= Factor for distance regulation

K3 =Factor for centre distance of sprockets

K4 =Factor for the position of the sprockets

K5 = Lubrication factor

K6 = Rating

factor The values of factors in various conditions are as follows:

### Load factor (K1)

Constant load	1.0
Variable load or load with mild shocks	1.25
Variable load or load with heavy shocks	1.5





**Factor from distance regulation (K2)**

Adjustable supports	1.0
Drive using idler sprocket	1.1
Fixed centre distance	1.25

**Factor for centre distance of sprockets (K3)**

$$\frac{L_p}{Z_1+Z_2} > 1 \text{ or } a_p < 25P \quad 1.25$$

$$\frac{L_p}{Z_1+Z_2} = 1.5 \text{ or } a_p = 30 \text{ to } 50P \quad 1.0$$

$$\frac{L_p}{Z_1+Z_2} \leq 2.0 \text{ or } a_p < 60 \text{ to } 80P \quad 0.8$$

Where  $L_p$  = Length of chain in multiples with pitch

**Factor for the position of sprockets (K4)**

Inclination of the line joining the centres of the sprockets to the horizontal upto  $60^\circ$  .....K4=1  
 More than  $60^\circ$ ..... K4=1.25

**Lubrication factor (K5)**

Conditions (oil-bath or forced lubrication) ..... K5 = 0.8  
 Drop-lubrication.....K5=1.0  
 Periodic ..... K5=1.

**Rating factor(K6)**

Single shift of 8 hours a day	K6=1.0
Double shift of 16 hours a day	K6=1.25
Continuous running	K6=1.5

**SELECTION PROCEDURE FOR CHAIN DRIVE**

According to manufacturer’s method, the following procedure can be adopted to select an appropriate chain for transmitting given power.

1. Depending upon the amount of power to be transmitted and other working conditions such as available space, chain speed, position of chain drive etc, select



the type of chain like bush chain or roller chain.

2. Assuming the centre distance between the chain sprockets in terms of pitches (usually from 30 to 50 P) determine the pitch of chain and adopt its standard value.
3. Determine the design power to be transmitted by considering safety factors as

$$P_d = P \times K_s$$

4. Calculate the developed load fro breaking the chain due to design power using the expression as

$$P = \frac{Qv}{k_n k_s} \quad \text{or} \quad P = \frac{P \cdot K_c \cdot K}{n} \text{ watts}$$

Where  $K_n$  = factor of safety which depends on speed of sprocket pinion and pitch.  
From table

$K_s$  = service factor which depends on various operating conditions

$$K_s = K_1 \cdot K_2 \cdot K_3 \cdot K_4 \cdot K_5 \cdot K_6$$

$$V = \text{chain velocity in m/s} \\ = \frac{Z_1 n_1 p}{60000} \text{ m/s or } v = \frac{Z_2 n_2 p}{60000} \text{ m/s}$$

Here  $Z_1, Z_2$  are number of teeth of sprocket pinion and sprocket wheel,  $n_1, n_2$  are the speeds in rpm of sprocket pinion and sprocket wheel, and  $p$  is the pitch of chain.

$Q$  = Breaking load in Newton's (i.e the developed tension or force on the chain due to power transmission)

$P$  = Rated power in watts.

5. For the determined pitch, choose a suitable chain from the table which should have more breaking (i.e resisting) strength than the above calculated breaking load.

I.e  $(Q) > Q$  where  $(Q)$  is the strength of selected chain and  $Q$  is the load developed (also called as breaking load)

Due to design power.

6. Find out the actual factor of safety this selected chain using the relation as

$$K_n = \frac{(Q)}{\sum F} \quad \text{where } \sum F = F_t + F_c + F_s \text{ from table}$$



Here (kn) = Actual factor of safety which should be greater than allowable value i.e (Kn) > Kn

$F_t$  = tangential force due to power transmission in Newton's

$$= \left( \frac{P}{v} \right) \text{ where } P \text{ is power in watts, } v \text{ is the velocity of chain in m/s}$$

$F_c$  = centrifugal tension in Newton's

$$= \left( \frac{Wv^2}{g} \right) \text{ where } W \text{ is the weight of chain per meter length in Newton's}$$

$F_s$  = tension due to sagging of chain in Newton's,

**Fs = k.w.a** where k is sagging coefficient from table and a is the centre distance in meters.

This table factor of safety is checked with the adopted value.

- Determine the induced stress over the projected area of the chain using the relation as

$$\sigma = \frac{P_d}{A_c v} \text{ or } \sigma = \frac{P}{A_c v} \text{ N/mm}^2$$

- Find the length of chain using the relation given in the table and provide allowance for initial sagging.
- Evaluate the pitch diameter of pinion-sprocket ( $d_1$ ) and wheel-sprocket ( $d_2$ ) using

$$d_1 = \frac{P}{\sin\left(\frac{180}{Z_1}\right)} \text{ and } d_2 = \frac{P}{\sin\left(\frac{180}{Z_2}\right)}$$

- Draw a neat sketch of chain drive with calculated specifications.

**Note:**

The empirical formula to determine the pitch of the chain in mm is given by

$$P \leq 10 \left[ \frac{60.67}{n^1} \right]^{2/3}$$

Where  $n^1$  = speed of small sprocket in rps (i.e  $n^1 = n_1/60$ )

**CHORDAL (POLYGONAL) ACTION OF ROLLER CHAIN**

In a chain drive, the smooth running of the chain, can be effected by the less number of sprocket-teeth. This type of unsmooth running is termed as chordal action of the chain. It can be explained as follows.



When the roller of a chain approaches the sprocket and has just, it has the radius  $r_c$ , known as chordal radius, as shown fig(a). When the roller travels through an angle of  $\alpha/2$  (half of the pitch angle), the roller has the radius  $r$ , which is the pitch radius and it is cleared that  $r > r_c$ . For  $N$  rom, the chain velocity for radius  $r$  is  $2\pi r_c N$ .

Since the velocity due to  $r$  is greater than the velocity due to  $r_c$ , it is obvious that, the chain is undergoing from minimum velocity to maximum velocity for every rotation which may affect the smooth running. The chordal rise  $\Delta r$  sis given by,

$$\Delta r = r - r_c = r - r \cos\left(\frac{\alpha}{2}\right) = r\left(1 - \cos\left(\frac{\alpha}{2}\right)\right)$$

This chordal rise  $\Delta r$  can be reduced by increasing the number of teeth  $Z$ , because  $\alpha = \frac{360}{Z}$ . The effect of chordal action can be reduced to negligible if there are 25 or more teeth on the sprocket. In order to distribute wear evenly on all the chain links, it is the usual practice to have number of teeth on the smaller sprocket and an even number of pitches in the chain.

### LINK CHAINS –AN OUTLINE STUDY

Link chains, also called as welded chains, are formed bending the required number of steel rods of specified length into oval shaped links and their ends are welded together after connecting each link with the other as shown in fig below . The dimensions of a link chain are its pitch ( $p$ ), outside width( $B$ ) and the diameter of chain rod( $d$ ).

Depending upon the value of pitch, the link chains are classified in to

- a) Short link chains (when  $p \leq 3d$ )
- b) Long link chains (when  $p > 3d$ )

Welded chains should be tested under load equal to one half the breaking load and no permanent set is permitted after the test.

Link chains are mostly used in some of the hand operated hoist mechanisms in which drum or pulley diameter ( $D$ ) should not be less than  $20d$ . In case of power mechanism  $D = 30d$ .

The general formula for selecting the welded chain in tension is  $P_s = \frac{P_b}{f_s}$

Where  $P_s$  = safe load to be carried by chain (or design load)

$P_b$  =Breaking load

$f_s$  = factor of safety (4 to 8)

The main advantages of link chains are i) good flexibility in all directions ii) simple design and the notable disadvantages are iii) Heavy susceptibility to jerk and overloads iv) Intensive wear of the links in the joints and sometimes sudden failure.





## SILENT CHAIN AND SIGNIFICANCE

The silent chain resembles with toothed or timing belt. The silent chain, also known as inverted toothed chain is constructed from a series of flat plates. Each plate has two projections or teeth. Each link, as it enters the sprocket, pivots about the pin of the adjacent link which is in contact with the sprocket. Thus the contact is gradual equal to almost three times the speed of simple roller chains. Even through the silent chain and timing belt, the power transmission capacity of silent chain is many times that of timings belt. The schematic diagram of a silent chain is shown in fig. The silent chain can be classified based on the type joint between the links such as i) Reynold chain and ii) Morse chain



(a) Chain with oval links.

(b) Chain with square links.

**Fig.** Hoisting and hauling chains.

The silent chains are mostly employed for high speed & high power applications. Because of the complicated structure of silent chain, its manufacturing cost is more and at the same time its run off from the sprocket (i.e shift) will be almost prevented. The silent chains are heavier, more expensive and require more careful maintenance. Due to the above reasons, they have limited applications.



**Ex1.**

A belt is required to transmit 18.5 kW from a pulley of 1.2 m diameter running at 250rpm to another pulley which runs at 500 rpm. The distance between the centers of pulleys is 2.7 m. The following data refer to an open belt drive,  $\mu = 0.25$ . Safe working stress for leather is 1.75 N/mm<sup>2</sup>. Thickness of belt = 10mm. Determine the width and length of belt taking centrifugal tension into account. Also find the initial tension in the belt and absolute power that can be transmitted by this belt and the speed at which this can be transmitted.

**Data:**

Open belt drive;  $N = 18.5 \text{ kW}$ ;  $n_1 = 500 \text{ rpm} = \text{Speed of smaller pulley}$ ;  
 $d_2 = 1.2 \text{ m} = 1200 \text{ mm} = D = \text{Diameter of larger pulley}$ ;  $n_2 = 250 \text{ rpm} = \text{Speed of larger pulley}$ ;  
 $C = 2.7 \text{ m} = 2700 \text{ mm}$ ;  $\mu = 0.25$ ;  $\sigma_1 = 1.75 \text{ N/mm}^2$ ;  $t = 10 \text{ mm}$

(i) **Diameter of smaller pulley**

$$n_1 d_1 = n_2 d_2$$

$$500 \times d_1 = 250 \times 1200$$

$$\therefore \text{Diameter of smaller pulley } d_1 = 600 \text{ mm} = d$$

(ii) **Velocity**

$$v = \frac{\pi(D+t)n_2}{60,000} = \frac{\pi(1200+10)250}{60,000} = 15.839 \text{ m/sec.}$$

(iii) **Centrifugal stress**

$$\sigma_c = \frac{wv^2}{g} \times 10^6$$

Assume specific weight of leather as  $10 \times 10^{-6} \text{ N/mm}^3$

$$\therefore \sigma_c = \frac{10 \times 10^{-6}}{9810} \times 15.839^2 \times 10^6 = 0.25573 \text{ N/mm}^2$$

(iv) **Capacity**

Since coefficient of friction is same for both smaller and larger pulleys, capacity =  $e^{\mu\theta}$

$$\text{i.e., } e^{\mu\theta} = e^{\mu\theta_s}$$

$$\theta_s = \pi - \left\{ 2 \sin^{-1} \left( \frac{D-d}{2C} \right) \right\} \frac{\pi}{180}$$

$$= \pi - \left\{ 2 \sin^{-1} \left( \frac{1200-600}{2 \times 2700} \right) \right\} \frac{\pi}{180} = 2.92 \text{ radians}$$

$$\therefore e^{\mu\theta} = e^{0.25 \times 2.92} = 2.075$$



(v) Constant

$$k = \frac{e^{\mu\theta} - 1}{e^{\mu\theta}} = \frac{2.075 - 1}{2.075} = 0.52$$

(vi) Width of belt

$$\begin{aligned} \text{Power transmitted per mm}^2 \text{ area} &= \frac{(\sigma_1 - \sigma_c)kv}{1000} \\ &= \frac{(1.75 - 0.25573)0.52 \times 15.839}{1000} = 0.01231 \text{ kW} \end{aligned}$$

(vii) Length of belt

$$\begin{aligned} \text{Length of open belt } L &= \sqrt{4C^2 - (D-d)^2} + \frac{1}{2}(D\theta_L + d\theta_s) \\ \theta_L &= \pi + \left\{ 2 \sin^{-1} \left( \frac{D-d}{2C} \right) \right\} \frac{\pi}{180} \\ &= \pi + \left\{ 2 \sin^{-1} \left( \frac{1200-600}{2 \times 2700} \right) \right\} \frac{\pi}{180} = 3.364 \text{ radians} \end{aligned}$$

$$L = \sqrt{4 \times 2700^2 - (1200 - 600)^2} + \frac{1}{2} (3.364 \times 1200 + 2.92 \times 600)$$

$$\therefore L = 8260.96 \text{ mm}$$

(viii) Initial tension

$$2\sqrt{T_o} = \sqrt{T_1} + \sqrt{T_2}$$

$$T_1 = \sigma_1 A = 1.75 \times 1503.18 = 2630.566 \text{ N}$$

$$\frac{\sigma_1 - \sigma_c}{\sigma_2 - \sigma_c} = e^{\mu\theta}; \frac{1.75 - 0.25573}{\sigma_2 - 0.25573} = 2.075; \therefore \sigma_2 = 0.97586 \text{ N/mm}^2$$

$$T_2 = \sigma_2 A = 0.97586 \times 1503.18 = 1466.894 \text{ N}$$

$$2\sqrt{T_o} = \sqrt{2630.566} + \sqrt{1466.894}$$

$$\therefore T_o = 2006.552 \text{ N}$$

(ix) Absolute power

For maximum power transmission

$$\sigma_c = \frac{\sigma_1}{3} = \frac{1.75}{3} = 0.5833 \text{ N/mm}^2$$

$$\text{Also } \sigma_c = \frac{w}{g} v^2 \times 10^6$$

$$\therefore 0.5833 = \frac{10 \times 10^{-6}}{9810} \times v^2 \times 10^6$$

$$\therefore v = 23.92 \text{ m/sec}$$

$$\begin{aligned} \therefore \text{Power transmitted \ mm}^2 &= \frac{(\sigma_1 - \sigma_c)kv}{1000} \\ &= \frac{(1.75 - 0.5833)0.52 \times 23.92}{1000} \\ &= 0.0145 \text{ kW} \end{aligned}$$

$$\begin{aligned} \therefore \text{Total absolute power} &= \text{Area of c/s of belt} \times \text{power per mm}^2 \\ &= 1503.18 \times 0.0145 = 21.7961 \text{ kW} \end{aligned}$$

$$\therefore \text{Absolute power} = 21.8 \text{ kW.}$$

**EX: 2**

Select a V-belt drive to transmit 10 kW of power from a pulley of 200 mm diameter mounted on an electric motor running at 720 rpm to another pulley mounted on compressor running at 200 rpm. The service is heavy duty varying from 10 hours to 14 hours per day and centre distance between centre of pulleys is 600 mm.

**Data:**

$N = 10 \text{ kW}; d_1 = 200 \text{ mm} = d; n_1 = 720 \text{ rpm}; n_2 = 200 \text{ rpm}; C = 600 \text{ mm}$   
Heavy duty 10 hours to 14 hours per day.

**Solution :**

**i. Diameter of larger pulley**

$$\begin{aligned} n_1 d_1 &= n_2 d_2 \\ 720 \times 200 &= 200 \times d_2 \\ \therefore d_2 &= 720 \text{ mm} = D = \text{diameter of larger pulley} \end{aligned}$$

**ii. Select the cross-section of belt**

Equivalent Pitch diameter of smaller pulley  $d_e = d_p F_b$  where  $d_p = d_1 = 200 \text{ mm}$

$$\frac{n_1}{n_2} = \frac{720}{200} = 3.6$$

From Table when  $\frac{n_1}{n_2} = 3.6$

Smaller diameter factor  $F_b = 1.14$

$$\therefore d_e = 200 \times 1.14 = 228 \text{ mm.}$$

iii. Velocity

$$v = \frac{\pi d_1 n_1}{60000} = \frac{\pi \times 200 \times 720}{60000} = 7.54 \text{ m/sec}$$

iv. Power capacity

For 'C' cross-section belt

$$\begin{aligned} N^* &= v \left[ \frac{1.47}{V^{0.09}} - \frac{143.27}{d_e} - \frac{2.34v^2}{10^4} \right] \\ &= 7.54 \left[ \frac{1.47}{7.54^{0.09}} - \frac{143.27}{228} - \frac{2.34 \times 7.54^2}{10^4} \right] \\ N^* &= 4.4 \text{ kW} \end{aligned}$$

Number of bolts:

$$i = \frac{NF_a}{N^* F_c \cdot F_d}$$

for heavy duty 10–14 hours/day correction factor for service  $F_a = 1.3$

$$\begin{aligned} L &= 2C + \frac{\pi}{2} (D+d) + \frac{(D-d)^2}{4C} \\ &= 2 \times 600 + \frac{\pi}{2} (720+200) + \frac{(720-200)^2}{4 \times 600} = 2757.8 \text{ mm} \end{aligned}$$

The nearest standard value of nominal pitch length for the selected C-cross section belt  $L = 2723$  mm, Nominal inside length = 2667 mm,

For nominal inside length = 2667 mm, and C-cross section belt, correction factor for length  $F_e = 0.94$

$$\begin{aligned} \text{Angle of contact } \theta &= 2 \cos^{-1} \left( \frac{D-d}{2C} \right) \\ &= 2 \cos^{-1} \left( \frac{720-200}{2 \times 600} \right) = 128.64^\circ \end{aligned}$$

From Table when  $\theta = 128.64^\circ$

Correction factor for angle of contact  $F_d = 0.86$  (Assume V-V belt)

$$\therefore i = \frac{10 \times 1.3}{4.4 \times 0.94 \times 0.86} = 3.655$$

$\therefore$  Number of V belts  $i = 4$



### EX.3

Select a roller chain drive to transmit power of 10 kw from a shaft rotating at 750 rpm to another shaft to run at 450 rpm. The distance between the shaft centers could be taken as 35 pitches.

Data:  $N = 10$  kw;  $n_1 = 750$  rpm;  $n_2 = 450$  rpm;  $C = 35$  pitches

#### 1. Pitch of chain

$$p \leq 25 \left( \frac{900}{n_1} \right)^{\frac{2}{3}}$$

$$\leq 25 \left( \frac{900}{750} \right)^{\frac{2}{3}}$$

$$\leq 28.23 \text{ mm}$$

From table 21.64, the nearest standard value of pitch  **$p = 25.4$  mm**

Select chain number 208 B

Breaking load  $F_u = 17.9$  kN = 17900 N

Measuring load  $w = 127.5$  N

#### 2. Number of teeth on the sprockets

$$\frac{n_1}{n_2} = \frac{750}{450} = 1.667$$

From Table 21.60 for  $\frac{n_1}{n_2} = 1.667$ , select number of teeth on the smaller sprocket  $z_1 = 27$

$$\text{Now } \frac{n_1}{n_2} = \frac{z_2}{z_1}$$

$$\frac{750}{450} = \frac{z_2}{27}$$

Number of teeth on larger sprocket  $z_2 = 45$

### 3. Pitch diameter

$$d = \frac{p}{\sin\left(\frac{180}{z}\right)}$$

$$\text{Pitch diameter of smaller sprocket } d_1 = \frac{p}{\sin\left(\frac{180}{z_1}\right)} = \frac{25.4}{\sin\left(\frac{180}{27}\right)} = 218.79 \text{ mm}$$

$$\text{Pitch diameter of larger sprocket } d_2 = \frac{p}{\sin\left(\frac{180}{z_2}\right)} = \frac{25.4}{\sin\left(\frac{180}{45}\right)} = 364.124 \text{ mm}$$

### 4. Velocity

$$v = \frac{pz_1 n_1}{60000} = \frac{25.4 \times 27 \times 750}{60000} = 8.57 \text{ m/sec}$$

### 5. Required pull

$$\text{Power } N = \frac{F_0 \cdot v}{1000 k_l k_s} \quad \text{---- 21.115a (DDHB)}$$

$$k_l = \text{Load factor} = 1.1 - 1.5$$

$$k_s = \text{Service factor}$$

$$= 1.2 \text{ for 24 hours operation (Assume 24 hours operation)}$$

$$\text{Take } k_l = 1.3$$

$$\therefore 10 = \frac{F_0 \times 8.57}{1000 \times 1.3 \times 1.2}$$

$$\therefore F_0 = 1820.3 \text{ N}$$

### 6. Allowable pull

$$F_a = \frac{F_u}{n_o} \text{ where } n_o = \text{Working factor of safety}$$

From Table 21.75 for  $n_1 = 750 \text{ rpm}$  and  $p = 25.4 \text{ mm}$

Select the working factor of safety  $n_o = 11.7$  [ $n_o$  is not equal to 10.7, printing error in DDHB]

$$\therefore F_a = \frac{17900}{11.7} = 1529.914$$

### 7. Number of strands

$$i = \frac{F_o}{F_a} = \frac{1820.3}{1529.914} = 1.189$$

∴ Number of strands  $i = 2$

### 8. Check for actual factor of safety

$$\text{Actual factor of safety } n_a = \left( \frac{F_u}{F_o + F_{cs} + F_s} \right) i$$

$$F_o = \frac{1000 \text{ N}}{v} = \frac{1000 \times 10}{8.57} = 1166.86 \text{ N}$$

$$F_{cs} = \frac{wv^2}{g} = \frac{127.5 \times 8.57^2}{9.81} = 954.56 \text{ N}$$

$$F_s = k_{sg} w C$$

From Table 21.58 for horizontal drive,  $k_{sg} = 6$

$$\therefore F_s = 6 \times 127.5 \times \frac{35 \times 25.4}{1000} = 680.085 \text{ N}$$

$$\therefore n_a = \left( \frac{17900}{1166.86 + 954.56 + 680.085} \right) \times 2 = 12.778$$

Since  $n_a > n_o$ , the selection of the chain is safe.

### 9. Length of chain in pitches

$$L_p = 2 C_p \cos \alpha + \frac{z_1 + z_2}{2} + \alpha \left( \frac{z_2 - z_1}{180} \right) \quad \text{--- 21.122 (DDHB)}$$

$$\alpha = \sin^{-1} \left( \frac{d_2 - d_1}{2C} \right) \quad \text{--- 21.122 (DDHB)}$$

$$= \sin^{-1} \left( \frac{364.124 - 218.79}{2 \times 35 \times 25.4} \right) = 4.6886^\circ$$

$$\therefore L_p = 2 \times 35 \cos 4.6886 + \left( \frac{27 + 45}{2} \right) + 4.6886 \left( \frac{45 - 27}{180} \right) \\ = 106.2346 \text{ pitches}$$

The nearest even number of pitches is 106

$$\therefore L_p = 106 \text{ pitches}$$

### 11. Correct centre distance

$$L_p = 2 \frac{C}{p} \cos \alpha + \frac{(z_2 + z_1)}{2} + \alpha \frac{(z_2 - z_1)}{180}$$

$$106 = 2 \times \frac{C}{25.4} \cos 4.6886 + \left( \frac{27 + 45}{2} \right) + 4.6886 \left( \frac{45 - 27}{180} \right)$$

$$\therefore C = 886 \text{ mm}$$

## UNIT-4

### Spur and helical Gear Drives

Mechanical drives may be categorized into two groups;

1. Drives that transmit power by means of friction: eg: belt drives and rope drives.
2. Drives that transmit power by means of engagement: eg: chain drives and gear drives.

However, the selection of a proper mechanical drive for a given application depends upon number of factors such as centre distance, velocity ratio, shifting arrangement, Maintenance and cost.

#### GEAR DRIVES

Gears are defined as toothed wheels, which transmit power and motion from one shaft to another by means of successive engagement of teeth.

1. The centre distance between the shafts is relatively small.
2. It can transmit very large power
3. It is a positive, and the velocity ratio remains constant.
4. It can transmit motion at a very low velocity.

#### CLASSIFICATION OF GEARS:

##### Four groups:

1. Spur Gears
2. Helical gears
3. Bevel gears and
4. Worm Gears

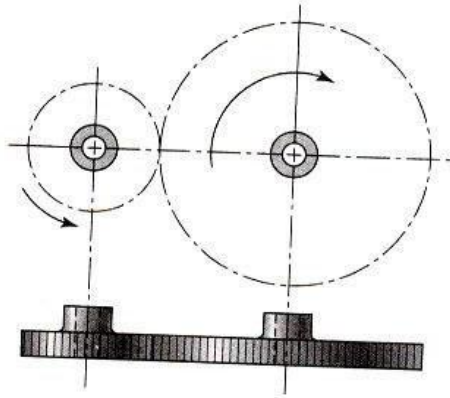

Spur Gear

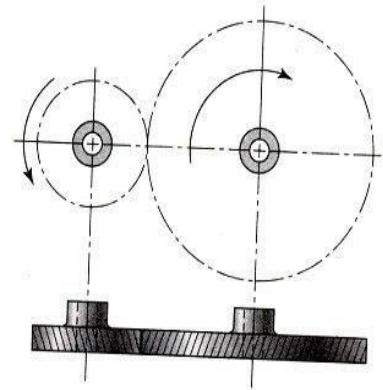

Helical Gear

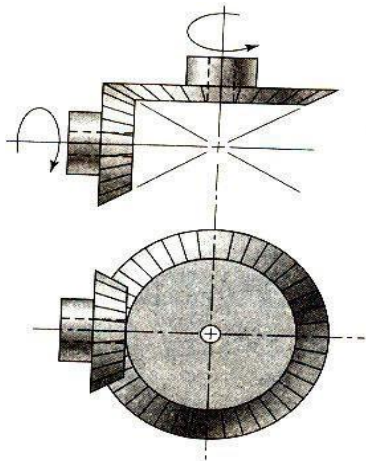

Bevel Gear

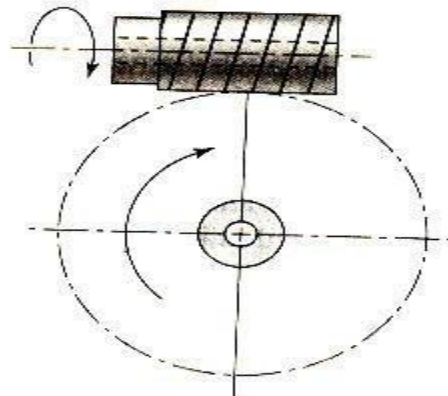

Worm Gear Set

### NOMEN CLATURE

Spur gears are used to transmit rotary motion between parallel shafts. They are usually cylindrical in shape and the teeth are straight and parallel to the axis of rotation.

In a pair of gears, the larger is often called the GEAR and, the smaller one is called the PINION

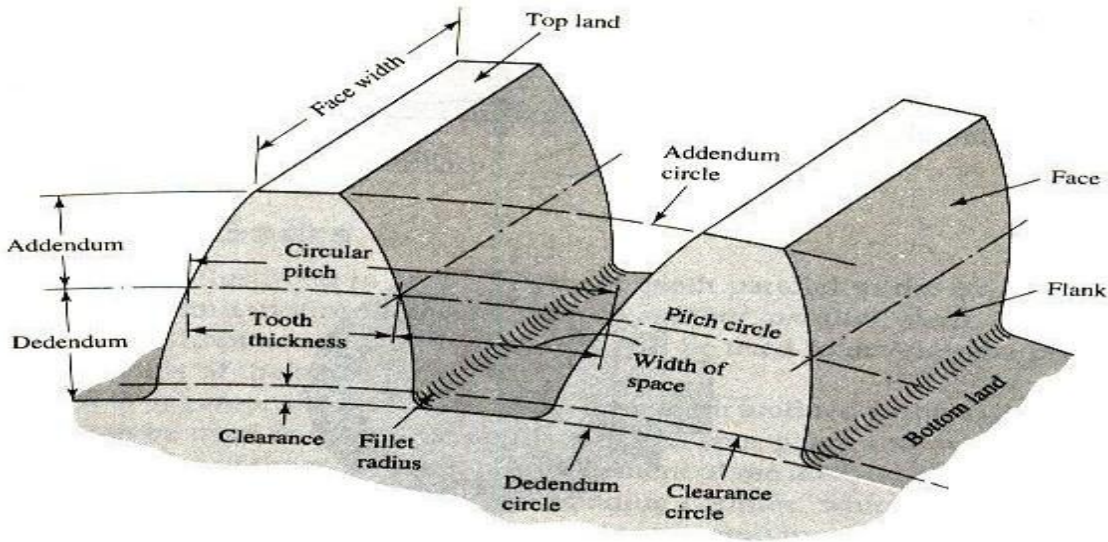

## Nomenclature of Spur Gear

1. **Pitch Surface:** The pitch surfaces of the gears are imaginary planes, cylinders or cones that roll together without slipping.
2. **Pitch circle:** It is a theoretical circle upon which all calculations are usually based. It is an imaginary circle that rolls without slipping with the pitch circle of a mating gear. Further, pitch circles of a mating gear are tangent to each other.
3. **Pitch circle diameter:** The pitch circle diameter is the diameter of pitch circle. Normally, the size of the gear is usually specified by pitch circle diameter. This is denoted by “d”
4. **Top land:** The top land is the surface of the top of the gear tooth
5. **Base circle:** The base circle is an imaginary circle from which the involute curve of the tooth profile is generated (the base circles of two mating gears are tangent to the pressure line)
6. **Addendum:** The Addendum is the radial distance between the pitch and addendum circles. Addendum indicates the height of tooth above the pitch circle.
7. **Dedendum:** The dedendum is the radial distance between pitch and the dedendum circles. Dedendum indicates the depth of the tooth below the pitch circle.
8. **Whole Depth:** The whole depth is the total depth of the tooth space that is the sum of addendum and Dedendum.

9. **Working depth:** The working depth is the depth of engagement of two gear teeth that is the sum of their addendums
10. **Clearance:** The clearance is the amount by which the Dedendum of a given gear exceeds the addendum of its mating tooth.
11. **Face:** The surface of the gear tooth between the pitch cylinder and the addendum cylinder is called face of the tooth.
12. **Flank:** The surface of the gear tooth between the pitch cylinder and the root cylinder is called flank of the tooth.
13. **Face Width:** is the width of the tooth measured parallel to the axis.
14. **Fillet radius:** The radius that connects the root circle to the profile of the tooth is called fillet radius.
15. **Circular pitch:** is the distance measured on the pitch circle, from a point on one tooth to a corresponding point on an adjacent tooth.
16. **Circular tooth thickness:** The length of the arc on pitch circle subtending a single gear tooth is called circular tooth thickness. Theoretically circular tooth thickness is half of circular pitch.
17. **Width of space (Tooth space):** The width of the space between two adjacent teeth measured along the pitch circle. Theoretically, tooth space is equal to circular tooth thickness or half of circular pitch
18. **Working depth:** The working depth is the depth of engagement of two gear teeth, that is the sum of their addendums
19. **Whole depth:** The whole depth is the total depth of the tooth space, that is the sum of addendum and dedendum and (this is also equal to whole depth + clearance)
20. **Centre distance:** it is the distance between centers of pitch circles of mating gears. (it is also equal to the distance between centers of base circles of mating gears)

21. **Line of action:** The line of action is the common tangent to the base circles of mating gears. The contact between the involute surfaces of mating teeth must be on this line to give smooth operation. The force is transmitted from the driving gear to the driven gear on this line.

22. **Pressure angle:** It is the angle that the line of action makes with the common tangent to the pitch circles.

23. **Arc of contact:** Is the arc of the pitch circle through which a tooth moves from the beginning to the end of contact with mating tooth.

24. **Arc of approach:** it is the arc of the pitch circle through which a tooth moves from its beginning of contact until the point of contact arrives at the pitch point.

25. **Arc of recess:** It is the arc of the pitch circle through which a tooth moves from the contact at the pitch point until the contact ends.

26. **Contact Ratio? Velocity ratio:** if the ratio of angular velocity of the driving gear to the angular velocity of driven gear. It is also called the speed ratio.

27. **Module:** It is the ratio of pitch circle diameter in milli meters to the number of teeth. it is usually denoted by 'm' Mathematically

$$m = D/Z$$

28. **Back lash:** It is the difference between the tooth space and the tooth thickness as measured on the pitch circle.

29. **Velocity Ratio:** Is the ratio of angular velocity of the driving gear to the angular velocity of driven gear. It is also called the speed ratio.



## NOTATION

### ENGLISH SYMBOLS

$A_o$	Centre distance
$B$	Face width
$D_a$	Addendum circle diameter
$D_o$	Pitch circle diameter
$d_r$	Root circle diameter
$m$	Module
$r_a$	Addendum circle radius
$r_b$	Base circle radius
$r_o$	Pitch circle radius
$R$	Radius of curvature of tooth profile
$R_g$	Gear ratio
$Z$	Number of teeth a Pressure angle
$\sigma$	Stress value
$\sigma_b$	Bending stress
$\sigma_{HB}$	Contact stress at the beginning of the engagement
$\sigma_{HE}$	Contact stress at the end of the engagement
$\sigma_{HL}$	Pitting limit stress
$\tau$	Shear stress
$\omega$	Angle velocity

Suffix 1 Pinion

Suffix 1 Gear

Nomenclature of Spur Gear

Failure Map of Involute Gears

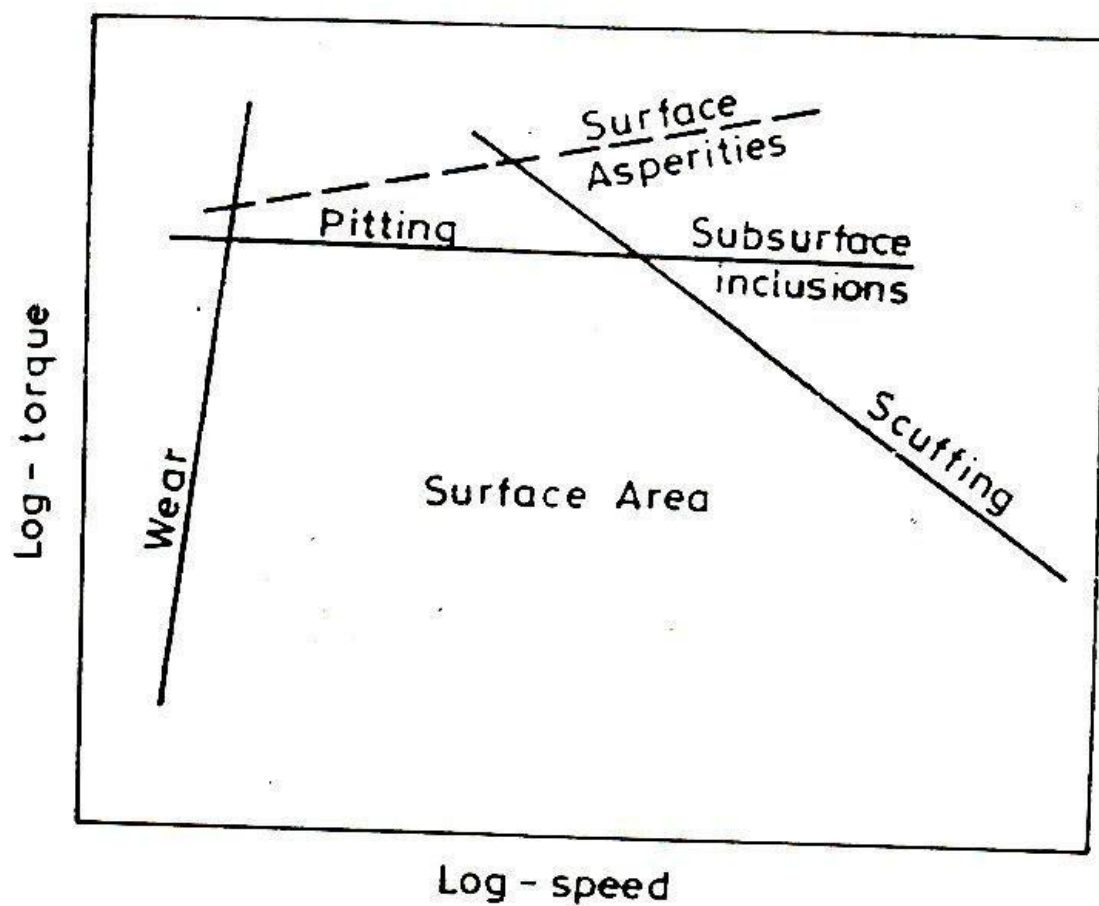

Failure Map of Involute Gears

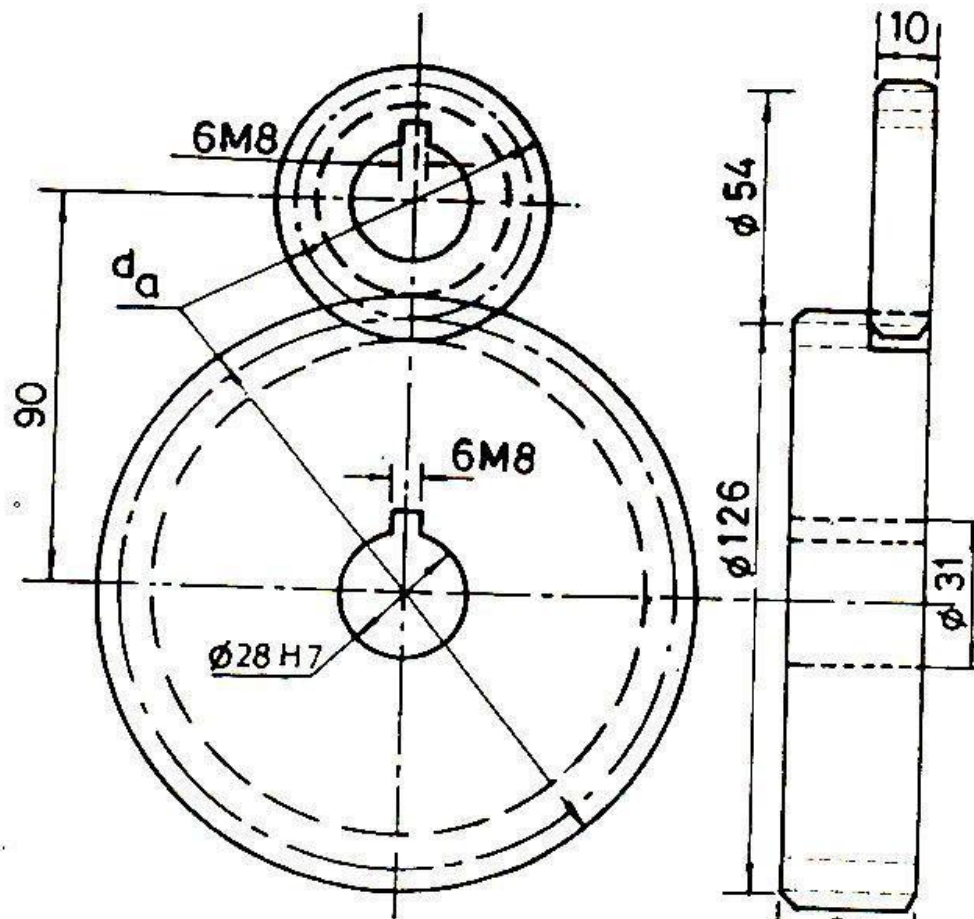

$$\alpha_o = 20^\circ; m = 3 \text{ mm}; z_1 = 1.8; z_2 = 42$$

Gear Set

### Specification of Test Pinions and Gears

Variable	Symbol	Unit	Values of variables used in the experiments		
			Pinion	Gears	
Module	m	(mm)		3.0	
Pressure angle	$\alpha_o$	(deg)		20°	
Number of teeth	z	(--)	18		42
Pitch circle diameter	d	(mm)	54.0		126.0
Centre distance	$a_o$	(mm)		90.0	
Addendum circle diameter	$d_a$	(mm)	60.0		132.0
Root circle diameter	$d_r$	(mm)	46.5		118.5
Face width	B	(mm)	10.0		30.0

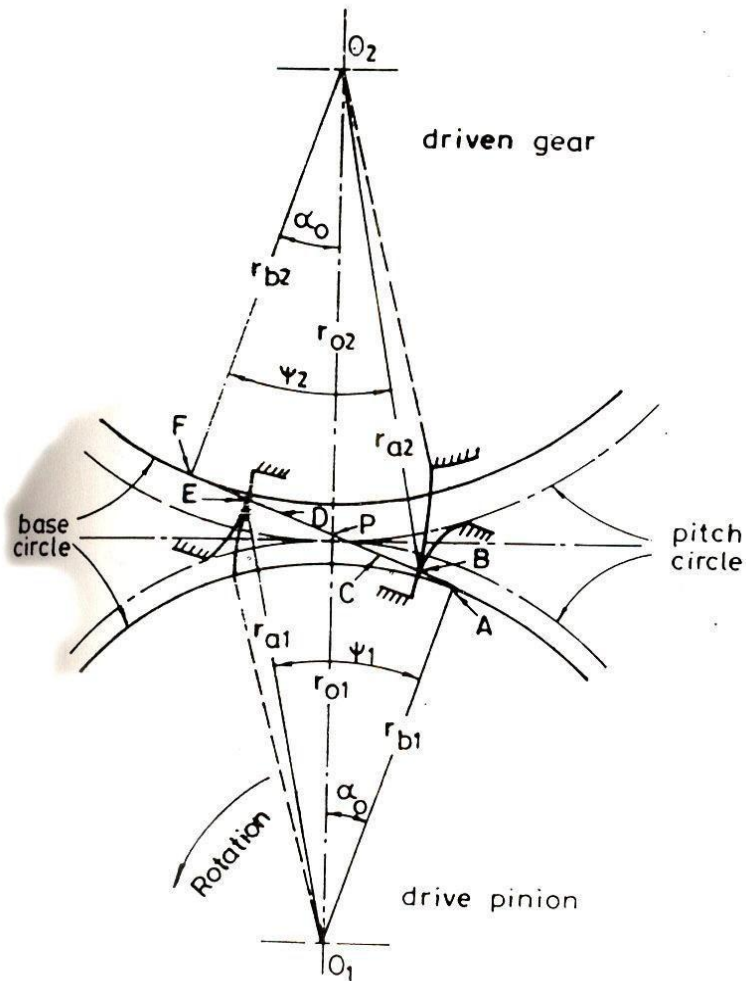

## Different Phases of Gear Tooth Contact

Phase of contact	Position and number of pairs of teeth (J) in contact	Radius of curvature	
		$R_1$	$R_2$
Beginning of engagement	B     2	$C_3 - C_2$	$C_2$
Transition phase	C     2 to 1	$C_1 - C_6$	$C_3 - C_1 - C_6$
Pitch point	P     1	$C_4$	$C_5$
Transition phase	D     1 to 2	$C_3 - C_2 + C_6$	$C_2 - C_6$
End of engagement	E     2	$C_1$	$C_3 - C_1$

Expressions for the Calculation of Equivalent Radii of Curvature at Various Phases of Contact

### Design consideration for a Gear drive

In the design of gear drive, the following data is usually given

- i. The power to be transmitted
- ii. The speed of the driving gear
- iii. The speed of the driven gear or velocity ratio
- iv. The centre distance

The following requirements must be met in the design of a gear drive

- (a) The gear teeth should have sufficient strength so that they will not fail under static loading or dynamic loading during normal running conditions
- (b) The gear teeth should have wear characteristics so that their life is satisfactory.
- (c) The use of space and material should be recommended
- (d) The alignment of the gears and deflections of the shaft must be considered because they effect on the performance of the gears
- (e) The lubrication of the gears must be satisfactory

## **Selection of Gears:**

The first step in the design of the gear drive is selection of a proper type of gear for a given application. The factors to be considered for deciding the type of the gear are

- General layout of shafts
- Speed ratio
- Power to be transmitted
- Input speed and
- Cost

**1. Spur & Helical Gears** – When the shaft are parallel

**2. Bevel Gears** – When the shafts intersect at right angles, and,

**3. Worm & Worm Gears** – When the axes of the shaft are perpendicular and not intersecting. As a special case, when the axes of the two shafts are neither intersecting nor perpendicular crossed helical gears are employed.

The speed reduction or velocity ratio for a single pair of spur or helical gears is normally taken as 6: 1. On rare occasions this can be raised to 10: 1. When the velocity ratio increases, the size of the gear wheel increases. This results in an increase in the size of the gear box and the material cost increases. For high speed reduction two stage or three stage construction are used.

The normal velocity ratio for a pair of bend gears is 1: 1 which can be increased to 3: 1 under certain circumstances.

For high-speed reduction worm gears offers the best choice. The velocity ratio in their case is 60: 1, which can be increased to 100: 1. They are widely used in materials handling equipment due to this advantage.

Further, spur gears generate noise in high-speed applications due to sudden contact over the entire face with between two meeting teeth. Whereas, in helical gears the contact between the two meshing teeth begins with a point and gradually extends along the tooth, resulting in quite operations.

From considerations spur gears are the cheapest. They are not only easy to manufacture but there exists a number of methods to manufacture them. The manufacturing of helical, bevel and worm gears is a specialized and costly operation.

**Law of Gearing:** The fundamental law of gearing states “The common normal to the both profile at the point of contact should always pass through a fixed point called the pitch point, in order to obtain a constant velocity ratio.

**MODULE:** The module specifies the size of gear tooth. Figure shows the actual sizes of gear tooth with four different modules. It is observed that as the modules increases, the size of the gear tooth also increases. It can be said that module is the index of the size of gear tooth.

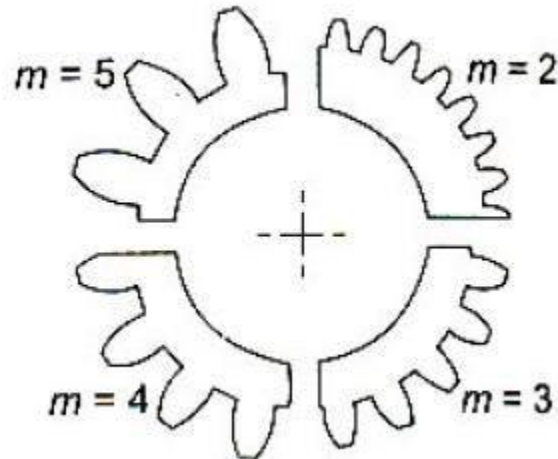

Standard values of module are as shown.

*Recommended Series of Modules (mm)*

Preferred (1)	Choice 2 (2)	Choice 3 (3)	Preferred (1)	Choice 2 (2)	Choice 3 (3)
1			8	7	(6.5)
1.25	1.125		10	9	
1.5	1.375		12	11	
2	1.75		16	14	
2.5	2.25		20	18	
3	2.75	(3.25)	25	22	
4	3.5		32	28	
5	4.5	(3.75)	40	36	
6	5.5		50	45	

**Note:** The modules given in the above table apply to spur and helical gears. In case of helical gears and double helical gears, the modules represent normal modules

The module given under choice 1, is always preferred. If that is not possible under certain circumstances module under choice 2, can be selected.

Standard proportions of gear tooth in terms of module  $m$ , for  $20^\circ$  full depth system.

Addendum =  $m$

Dedendum =  $1.25 m$

Clearance ( $c$ ) =  $0.25 m$

Working depth =  $2 m$

Whole depth =  $2.25 m$

Tooth thickness =  $1.5708 m$   $\left[ \frac{\pi d}{2z} = \frac{\pi m z}{2z} \right] = 1.5708 m$

Tooth space =  $1.5708 m$

Fillet radius =  $0.4 m$

### Standard Tooth proportions of involute spur gear

Gear Terms	Circular pitch $p$	Diametral pitch $P$	Module $m$
Addendum	$0.3183 p$	$1/P$	$m$
Dedendum	$0.3977 p$	$1.25/P$	$1.25 m$
Tooth thickness	$0.5 p$	$1.5708/P$	$1.5708 m$
Tooth space	$0.5 p$	$1.5708/P$	$1.5708 m$
Working depth	$0.6366 p$	$2/P$	$2 m$
Whole depth	$0.7160 p$	$2.25/P$	$2.25 m$
Clearance	$0.0794 p$	$0.25/P$	$0.25 m$
Pitch diameter	$zp/\pi$	$z/P$	$zm$
Outside diameter	$(z+2)p/\pi$	$(z+2)/P$	$(z+2) m$
Root diameter	$(z - 2.5)p/\pi$	$(z - 2.5)/P$	$(z - 2.5) m$
Fillet radius	$0.1273p$	$0.4/P$	$0.4 m$

### Selection of Material:

- The load carrying capacity of the gear tooth depends upon the ultimate tensile strength or yield strength of the material.
- When the gear tooth is subjected to fluctuating forces, the endurance strength of the tooth is the deciding factor.



- The gear material should have sufficient strength to resist failure due to breakage of the tooth.
- In many cases, it is wear rating rather than strength rating which decides the dimensions of gear tooth.
- The resistance to wear depends upon alloying elements, grain size, percentage of carbon and surface hardness.
- The gear material should have sufficient surface endurance strength to avoid failure due to destructive pitting.
- For high-speed power transmission, the sliding velocities are very high and the material should have a low coefficient of friction to avoid failure due to scoring.
- The amount of thermal distortion or warping during the heat treatment process is a major problem on gear application.
- Due to warping the load gets concentrated at one corner of the gear tooth.
- Alloy steels are superior to plain carbon steel in this respect (Thermal distortion)

### **Load-Distribution Factor $K_m$ (KH)**

The load-distribution factor modified the stress equations to reflect non uniform distribution of load across the line of contact. The ideal is to locate the gear “midspan” between two bearings at the zero slope place when the load is applied. However, this is not always possible. The following procedure is applicable to

- Net face width to pinion pitch diameter ratio  $F/d \leq 2$
- Gear elements mounted between the bearings
- Face widths up to 40 in
- Contact, when loaded, across the full width of the narrowest member

The load-distribution factor under these conditions is currently given by the *face load* distribution factor,  $C_{mf}$ , where

$$K_m = C_{mf} = 1 + C_{mc} (C_{pf} C_{pm} + C_{ma} C_e)$$

Where

$$C_{mc} = \begin{cases} 1 & \text{for uncrowned teeth} \\ 0.8 & \text{for crowned teeth} \end{cases}$$

$$C_{pf} = \begin{cases} \frac{F}{10d} - 0.025 & F \leq 1 \text{ in} \\ \frac{F}{10d} - 0.0375 + 0.0125F & 1 < F \leq 17 \text{ in} \\ \frac{F}{10d} - 0.1109 + 0.0207F - 0.000228F^2 & 17 < F \leq 40 \text{ in} \end{cases}$$

Note that for values of  $F/(10d) < 0.05$ ,  $F/(10d) = 0.05$  is used.

$$C_{pm} = \begin{cases} 1 & \text{for straddle-mounted pinion with } S_1/S < 0.175 \\ 1.1 & \text{for straddle-mounted pinion with } S_1/S \geq 0.175 \end{cases}$$

$$C_{ma} = A + BF + CF^2 \quad (\text{see Table 14-9 for values of } A, B, \text{ and } C)$$

$$C_e = \begin{cases} 0.8 & \text{for gearing adjusted at assembly, or compatibility} \\ & \text{is improved by lapping, or both} \\ 1 & \text{for all other conditions} \end{cases}$$

### Force analysis – Spur gearing.

We know that, the reaction between the mating teeth occur along the pressure line, and the power is transmitted by means of a force exerted by the tooth of the driving gear on the meshing tooth of the driven gear. (i.e. driving pinion exerting force PN on the tooth of driven gear).

According to fundamental law of gear this resultant force  $P_N$  always acts along the pressure line.

This resultant force  $P_N$ , can be resolved into two components – tangential component  $P_t$  and radial components  $P_r$  at the pitch point.

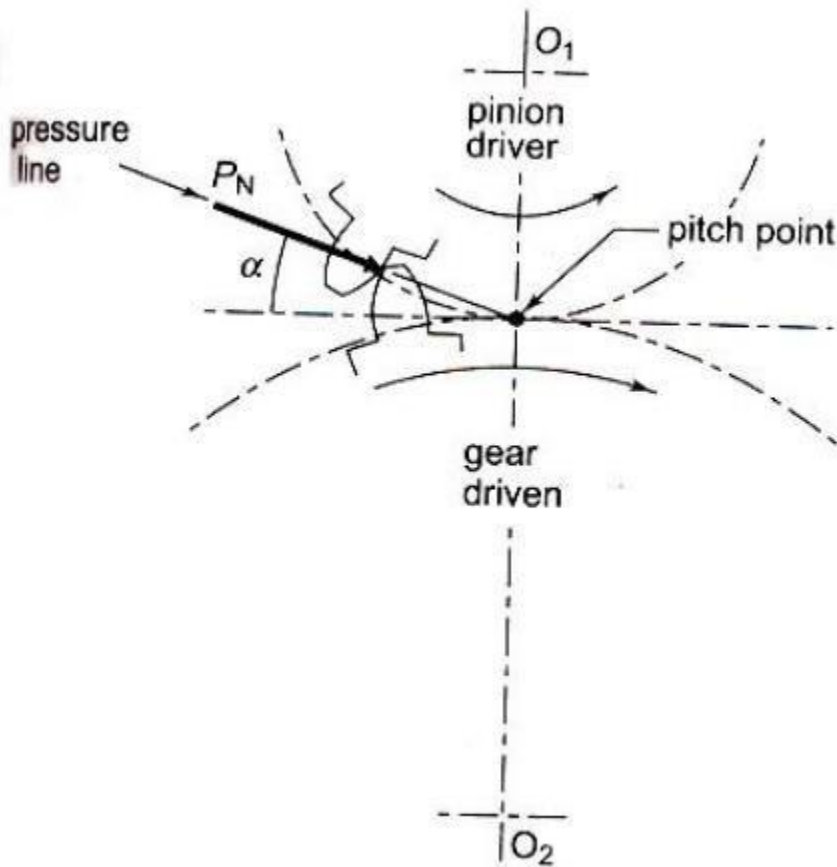

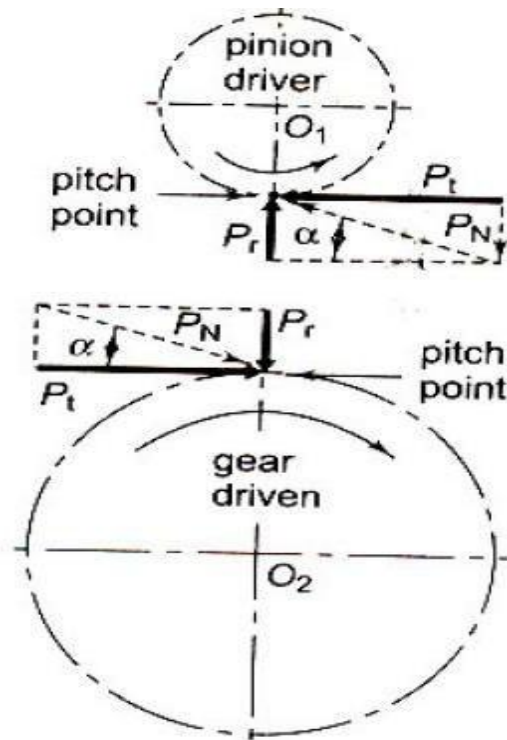

The tangential component \$P\_t\$ is a useful component (load) because it determines the magnitude of the torque and consequently the power, which is transmitted.

The radial component \$P\_r\$ services no useful purpose (it is a separating force) and it is always directed towards the centre of the gear.

The torque transmitted by the gear is given by

$$M_t = \frac{P \times 60}{2 \pi N_1} \text{ N-m}$$

Where, \$M\_t\$ = Torque transmitted gears (N- m)

\$P\$ = Power transmitted by gears

\$N\_1\$ = Speed of rotation (rev / mn)

The tangential component \$F\_t\$ acts at the pitch circle radius.

$$\therefore M_t = F_t \frac{d}{2}$$

OR

$$F_t = \frac{2M_t}{d}$$

Where,

$M_t$  = Torque transmitted gears N- mm

$d$  = Pitch Circle diameter, mm

Further, we know,

Power transmitted by gears =  $2 \pi N M_t / 60$  (KW)

Where

$$F_r = F_t \tan \alpha$$

Resultant force,

$$F_N = \frac{F_t}{\cos \alpha}$$

The above analysis of gear tooth force is based on the following assumptions.

- i) As the point of contact moves the magnitude of resultant force  $F_N$  changes. This effect is neglected.
- ii) It is assumed that only one pair of teeth takes the entire load. At times, there are two pairs that are simultaneously in contact and share the load. This aspect is also neglected.

iii) This analysis is valid under static conditions for example, when the gears are running at very low velocities. In practice there are dynamic forces in addition to force due to power transmission.

For gear tooth forces, It is always required to find out the magnitude and direction of two components. The magnitudes are determined by using equations

$$M_t = \frac{P \times 60}{2\pi N_1}$$

$$F_t = \frac{2M_t}{d_1}$$

Further, the direction of two components  $F_t$  and  $F_r$  are decided by constructing the free body diagram.

?

How

Minimum Number of Teeth:

The minimum number of teeth on pinion to avoid interference is given by

$$Z_{\min} = \frac{2}{\sin^2 \alpha}$$

For 20° full depth involute system, it is always safe to assume the number of teeth as 18 or 20

Once the number of teeth on the pinion is decided, the number of teeth on the gear is calculated by the velocity ratio

$$i = \frac{Z_2}{Z_1}$$

## Face Width:

In designing gears, it is required to express the face width in terms of module.

In practice, the optimum range of face width is  $9.5 m \leq b \leq 12.5m$

Generally, face width is assumed as ten times module

$$\therefore \boxed{b = 12.5m}$$

## Systems of Gear Teeth

The following four systems of gear teeth are commonly used in practice.

**1.**  $14\frac{1}{2}^\circ$  Composite system, **2.**  $14\frac{1}{2}^\circ$  Full depth involute system, **3.**  $20^\circ$  Full depth involute system, and **4.**  $20^\circ$  Stub involute system.

The  $14\frac{1}{2}^\circ$  *composite system* is used for general purpose gears. It is stronger but has no interchangeability.

The tooth profile of this system has cycloidal curves at the top and bottom and involute curve at the middle portion. The teeth are produced by formed milling cutters or hobs. The tooth profile of the  $14\frac{1}{2}^\circ$  *full depth involute system* was developed for use with gear hobs for spur and helical gears.

The tooth profile of the  $20^\circ$  *full depth involute system* may be cut by hobs. The increase of the pressure angle from  $14\frac{1}{2}^\circ$  to  $20^\circ$  results in a stronger tooth, because the tooth acting as a beam is wider at the base. The  $20^\circ$  *stub involute system* has a strong tooth to take heavy loads.

## Standard Proportions of Gear Systems

The following table shows the standard proportions in module ( $m$ ) for the four gear systems as discussed in the previous article.

**Table 4.1. Standard proportions of gear systems.**

S. No.	Particulars	$14\frac{1}{2}^\circ$ composite or full depth involute system	$20^\circ$ full depth involute system	$20^\circ$ stub involute system
1.	Addendum	$1m$	$1m$	$0.8m$
2.	Dedendum	$1.25m$	$1.25m$	$1m$
3.	Working depth	$2m$	$2m$	$1.60m$
4.	Minimum total depth	$2.25m$	$2.25m$	$1.80m$
5.	Tooth thickness	$1.5708m$	$1.5708m$	$1.5708m$
6.	Minimum clearance	$0.25m$	$0.25m$	$0.2m$
7.	Fillet radius at root	$0.4m$	$0.4m$	$0.4m$

### Causes of Gear Tooth Failure

The different modes of failure of gear teeth and their possible remedies to avoid the failure, are as follows:

**1. Bending failure.** Every gear tooth acts as a cantilever. If the total repetitive dynamic load acting on the gear tooth is greater than the beam strength of the gear tooth, then the gear tooth will fail in bending, *i.e.* the gear tooth will break.

In order to avoid such failure, the module and face width of the gear is adjusted so that the beam strength is greater than the dynamic load.

**2. Pitting.** It is the surface fatigue failure which occurs due to many repetition of Hertz contact stresses. The failure occurs when the surface contact stresses are higher than the endurance limit of the material. The failure starts with the formation of pits which continue to grow resulting in the rupture of the tooth surface.

In order to avoid the pitting, the dynamic load between the gear tooth should be less than the wear strength of the gear tooth.

**3. Scoring.** The excessive heat is generated when there is an excessive surface pressure, high speed or supply of lubricant fails. It is a stick-slip phenomenon in which alternate shearing and welding takes place rapidly at high spots.



This type of failure can be avoided by properly designing the parameters such as speed, pressure and proper flow of the lubricant, so that the temperature at the rubbing faces is within the permissible limits.

**4. Abrasive wear.** The foreign particles in the lubricants such as dirt, dust or burr enter between the tooth and damage the form of tooth. This type of failure can be avoided by providing filters for the lubricating oil or by using high viscosity lubricant oil which enables the formation of thicker oil film and hence permits easy passage of such particles without damaging the gear surface.

**5. Corrosive wear.** The corrosion of the tooth surfaces is mainly caused due to the presence of corrosive elements such as additives present in the lubricating oils. In order to avoid this type of wear, proper anti-corrosive additives should be used.

## Design Procedure for Spur Gears

In order to design spur gears, the following procedure may be followed:

**1.** First of all, the design tangential tooth load is obtained from the power transmitted and the pitch line velocity by using the following relation :

$$W_T = \frac{P}{v} \times C_s \quad \dots(i)$$

where

$W_T$  = Permissible tangential tooth load in newtons,

$P$  = Power transmitted in watts,

\* $v$  = Pitch line velocity in m / s =  $\frac{\pi D N}{60}$ ,

$D$  = Pitch circle diameter in metres,

---

\* We know that circular pitch,

$$p_c = \pi D / T = \pi m$$

$$\dots(\because m = D / T)$$

$$\therefore D = m.T$$

Thus, the pitch line velocity may also be obtained by using the following relation, *i.e.*

$$v = \frac{\pi D.N}{60} = \frac{\pi m.T.N}{60} = \frac{p_c.T.N}{60}$$

where

$m$  = Module in metres, and

$T$  = Number of teeth.

$N$  = Speed in r.p.m., and

$C_s$  = Service factor.

The following table shows the values of service factor for different types of loads:

**Table 4.2. Values of service factor.**

Type of load	Type of service		
	Intermittent or 3 hours per day	8-10 hours per day	Continuous 24 hours per day
Steady	0.8	1.00	1.25
Light shock	1.00	1.25	1.54
Medium shock	1.25	1.54	1.80
Heavy shock	1.54	1.80	2.00

**Note:** The above values for service factor are for enclosed well lubricated gears. In case of non-enclosed and grease lubricated gears, the values given in the above table should be divided by 0.65.

2. Apply the Lewis equation as follows :

$$\begin{aligned}
 W_T &= \sigma_w \cdot b \cdot p_c \cdot y = \sigma_w \cdot b \cdot \pi m \cdot y \\
 &= (\sigma_o \cdot C_v) b \cdot \pi m \cdot y \quad \dots (\because \sigma_w = \sigma_o \cdot C_v)
 \end{aligned}$$

**Notes:** (i) The Lewis equation is applied only to the weaker of the two wheels (*i.e.* pinion or gear).

(ii) When both the pinion and the gear are made of the same material, then pinion is the weaker.

(iii) When the pinion and the gear are made of different materials, then the product of  $(\sigma_w \times y)$  or  $(\sigma_o \times y)$  is the \*deciding factor. The Lewis equation is used to that wheel for which  $(\sigma_w \times y)$  or  $(\sigma_o \times y)$  is less.

\* We see from the Lewis equation that for a pair of mating gears, the quantities like  $W_T$ ,  $b$ ,  $m$  and  $C_v$  are constant. Therefore  $(\sigma_w \times y)$  or  $(\sigma_o \times y)$  is the only deciding factor.

(iv) The product  $(\sigma_w \times y)$  is called **strength factor** of the gear.

(v) The face width ( $b$ ) may be taken as 3  $pc$  to 4  $pc$  (or 9.5  $m$  to 12.5  $m$ ) for cut teeth and 2  $pc$  to 3  $pc$  (or 6.5  $m$  to 9.5  $m$ ) for cast teeth.

3. Calculate the dynamic load ( $W_D$ ) on the tooth by using Buckingham equation, *i.e.*

$$\begin{aligned}
 W_D &= W_T + W_I \\
 &= W_T + \frac{21v(b.C + W_T)}{21v + \sqrt{b.C + W_T}}
 \end{aligned}$$

In calculating the dynamic load ( $W_D$ ), the value of tangential load ( $W_T$ ) may be calculated by neglecting the service factor ( $CS$ ) *i.e.*

$W_T = P / v$ , where  $P$  is in watts and  $v$  in m / s.

4. Find the static tooth load (*i.e.* beam strength or the endurance strength of the tooth) by using the relation,

$$W_S = \sigma_e \cdot b \cdot pc \cdot y = \sigma_e \cdot b \cdot \pi \cdot m \cdot y$$

For safety against breakage,  $W_S$  should be greater than  $W_D$ .

5. Finally, find the wear tooth load by using the relation,

$$W_w = D_p \cdot b \cdot Q \cdot K$$

The wear load ( $W_w$ ) should not be less than the dynamic load ( $W_D$ ).

**Example 1.** The following particulars of a single reduction spur gear are given:

Gear ratio = 10: 1; Distance between centers = 660 mm approximately; Pinion transmits 500 kW at 1800 r.p.m.; Involute teeth of standard proportions (addendum =  $m$ ) with pressure angle of  $22.5^\circ$ ; Permissible normal pressure between teeth = 175 N per mm of width. Find:

1. The nearest standard module if no interference is to occur;
2. The number of teeth on each wheel;
3. The necessary width of the pinion; and
4. The load on the bearings of the wheels due to power transmitted.

**Solution:** Given:  $G = T_G / T_P = D_G / D_P = 10$ ;  $L = 660$  mm;  $P = 500$  kW =  $500 \times 10^3$  W;  
 $N_P = 1800$  r.p.m. ;  $\phi = 22.5^\circ$  ;  $W_N = 175$  N/mm width

### 1. Nearest standard module if no interference is to occur

Let  $m$  = Required module,  
 $T_P$  = Number of teeth on the pinion,  
 $T_G$  = Number of teeth on the gear,  
 $D_P$  = Pitch circle diameter of the pinion, and  
 $D_G$  = Pitch circle diameter of the gear.

We know that minimum number of teeth on the pinion in order to avoid interference,

$$T_P = \frac{2 A_W}{G \left[ \sqrt{1 + \frac{1}{G} \left( \frac{1}{G} + 2 \right) \sin^2 \phi} - 1 \right]}$$

$$= \frac{2 \times 1}{10 \left[ \sqrt{1 + \frac{1}{10} \left( \frac{1}{10} + 2 \right) \sin^2 22.5^\circ} - 1 \right]} = \frac{2}{0.15} = 13.3 \text{ say } 14$$

... ( $\because A_W = 1$  module)

$\therefore T_G = G \times T_P = 10 \times 14 = 140$  ... ( $\because T_G / T_P = 10$ )

We know that  $L = \frac{D_G}{2} + \frac{D_P}{2} = \frac{D_G}{2} + \frac{10 D_P}{2} = 5.5 D_P$  ... ( $\because D_G / D_P = 10$ )

$\therefore 660 = 5.5 D_P$  or  $D_P = 660 / 5.5 = 120$  mm

We also know that  $D_P = m \cdot T_P$

$\therefore m = D_P / T_P = 120 / 14 = 8.6$  mm

Since the nearest standard value of the module is 8 mm, therefore we shall take  $m = 8$  mm **Ans.**

## 2. Number of teeth on each wheel

We know that number of teeth on the pinion,

$$T_P = D_P / m = 120 / 8 = 15 \text{ Ans.}$$

and number of teeth on the gear,

$$T_G = G \times T_P = 10 \times 15 = 150 \text{ Ans.}$$

## 3. Necessary width of the pinion

We know that the torque acting on the pinion,

$$T = \frac{P \times 60}{2 \pi N_P} = \frac{500 \times 10^3 \times 60}{2 \pi \times 1800} = 2652 \text{ N-m}$$

$$\therefore \text{Tangential load, } W_T = \frac{T}{D_P / 2} = \frac{2652}{0.12 / 2} = 44\,200 \text{ N} \quad \dots (\because D_P \text{ is taken in metres})$$

and normal load on the tooth,

$$W_N = \frac{W_T}{\cos \phi} = \frac{44\,200}{\cos 22.5^\circ} = 47\,840 \text{ N}$$

Since the normal pressure between teeth is 175 N per mm of width, therefore necessary width of the pinion,

$$b = \frac{47\,840}{175} = 273.4 \text{ mm Ans.}$$

## 4. Load on the bearings of the wheels

We know that the radial load on the bearings due to the power transmitted,

$$W_R = W_N \cdot \sin \phi = 47\,840 \times \sin 22.5^\circ = 18\,308 \text{ N} = 18.308 \text{ kN Ans.}$$

## Spur Gear Construction

The gear construction may have different designs depending upon the size and its application. When the dedendum circle diameter is slightly greater than the shaft diameter, then the pinion teeth are cut integral with the shaft as shown in Fig. 28.13 (a). If the pitch circle diameter of the pinion is less than or equal to  $14.75 m + 60 \text{ mm}$  (where  $m$  is the module in mm), then the pinion is made solid with uniform thickness equal to the face width, as shown in Fig. 28.13 (b). Small gears up to 250 mm pitch circle diameter are built with a web, which joins the hub and the rim. The web thickness is generally equal to half the circular pitch or it may be taken as  $1.6 m$  to  $1.9 m$ , where  $m$  is the module. The web may be made solid as shown in Fig. 28.13 (c) or may have recesses in order to reduce its weight.

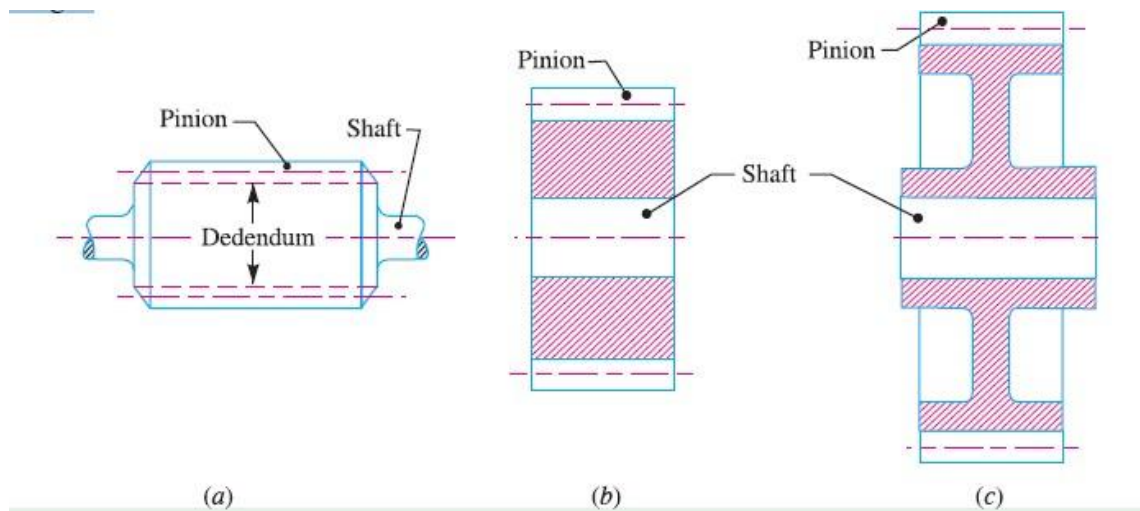

**Fig.** Construction of spur gears.

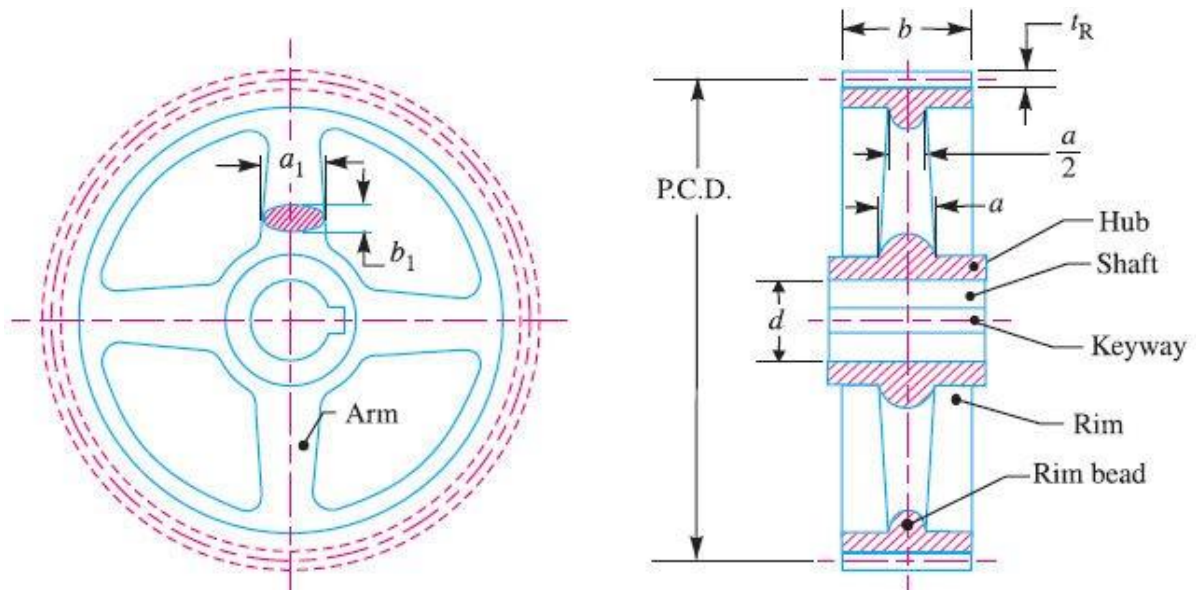

**Fig. Gear with arms.**

Large gears are provided with arms to join the hub and the rim, as shown in Fig. 28.14. The number of arms depends upon the pitch circle diameter of the gear. The number of arms may be selected from the following table.

**Table 4.3. Number of arms for the gears.**

<i>S. No.</i>	<i>Pitch circle diameter</i>	<i>Number of arms</i>
1.	Up to 0.5 m	4 or 5
2.	0.5 – 1.5 m	6
3.	1.5 – 2.0 m	8
4.	Above 2.0 m	10

The cross-section of the arms is most often elliptical, but other sections as shown in Fig.15 may also be used.

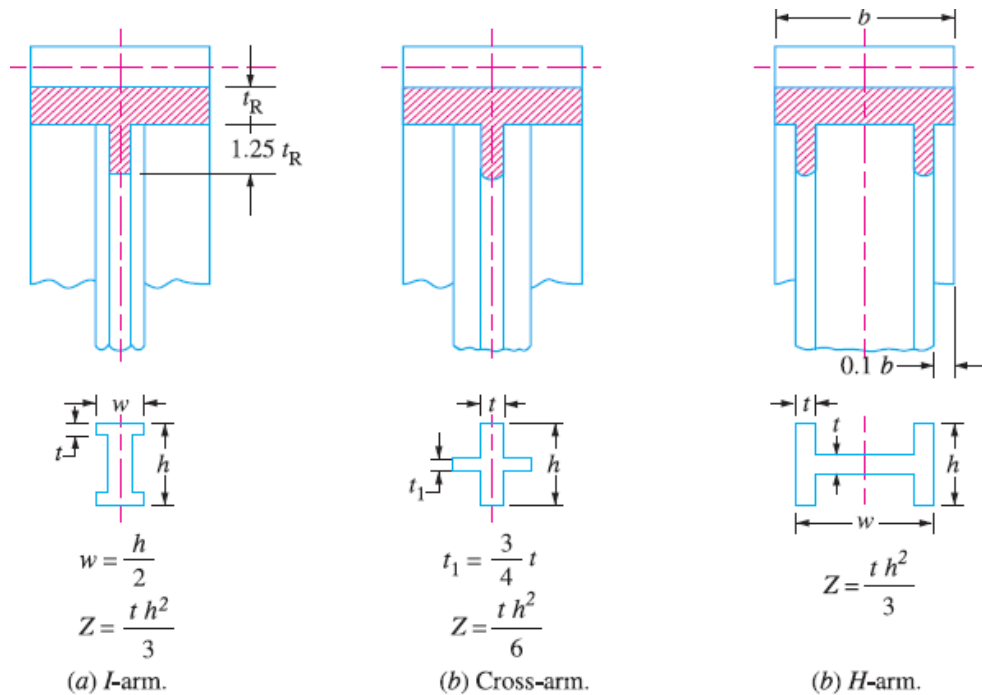

**Fig.** Cross-section of the arms.

The hub diameter is kept as 1.8 times the shaft diameter for steel gears, twice the shaft diameter for cast iron gears and 1.65 times the shaft diameter for forged steel gears used for light service. The length of the hub is kept as 1.25 times the shaft diameter for light service and should not be less than the face width of the gear.

The thickness of the gear rim should be as small as possible, but to facilitate casting and to avoid sharp changes of section, the minimum thickness of the rim is generally kept as half of the circular pitch (or it may be taken as  $1.6 m$  to  $1.9 m$ , where  $m$  is the module). The thickness of rim ( $t_R$ ) may also be calculated by using the following relation, *i.e.*

$$t_R = m \sqrt{\frac{T}{n}}$$

Where

$T$  = Number of teeth, and

$n$  = Number of arms.

The rim should be provided with a circumferential rib of thickness equal to the rim thickness.

## SPUR GEAR – TOOTH FORCE ANALYSIS

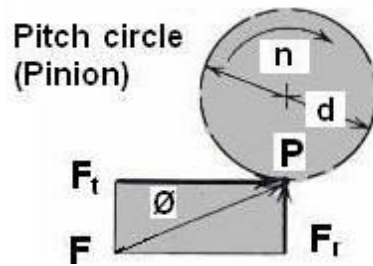

**Fig. Spur gear – tooth force analysis**

As shown in Fig. 7.1, the normal force  $F$  can be resolved into two components; a tangential force  $F_t$  which does transmit the power and radial component  $F_r$  which does no work but tends to push the gears apart. They can hence be written as,

$$F_t = F \cos \phi \quad (4.1)$$

$$F_r = F \sin \phi \quad (4.2)$$

From eqn. (4.2),

$$F_r = F_t \tan \phi \quad (4.3)$$

The pitch line velocity  $V$ , in meters per second, is given as

$$V = \frac{\pi d n}{6000} \quad (4.4)$$

$$W = \frac{F_t V}{1000} \quad (4.5)$$

Where  $d$  is the pitch diameter of the gear in millimeters and  $n$  is the rotating speed in rpm and  $W$  power in kW.



## SPUR GEAR - TOOTH STRESSES

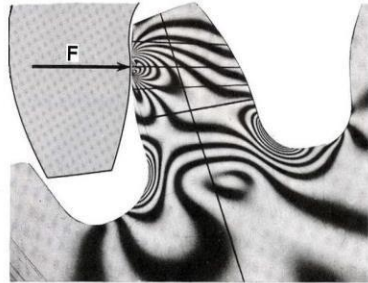

Stresses developed by Normal force in a photo-elastic model of gear tooth as per Dolan and Broghammer are shown in above Fig. The highest stresses exist at regions where the lines are bunched closest together. The highest stress occurs at two locations:

- A. At contact point where the force  $F$  acts
- B. At the fillet region near the base of the tooth.

## SPUR GEAR - LEWIS EQUATION FOR TOOTH BENDING STRESS

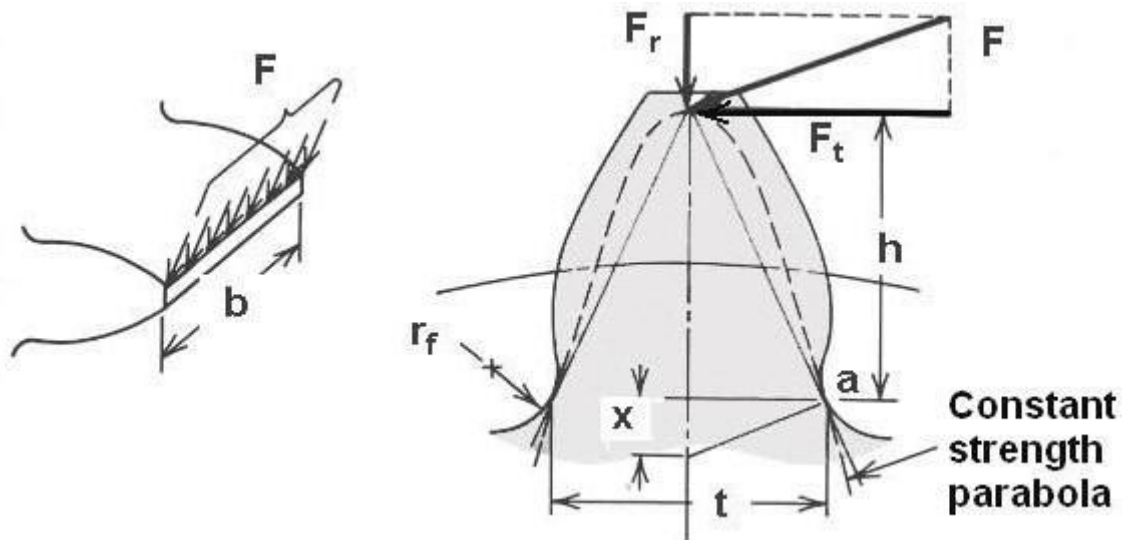

**Fig. Gear tooth as cantilever beam**

Lewis considered gear tooth as a cantilever beam with static normal force  $F$  applied at the tip. Assumptions made in the derivation are:

1. The full load is applied to the tip of a single tooth in static condition.
2. The radial component is negligible.
3. The load is distributed uniformly across the full face width.
4. Forces due to tooth sliding friction are negligible.
5. Stress concentration in the tooth fillet is negligible.

The above Fig. shows clearly that the gear tooth is stronger throughout than the inscribed constant strength parabola, except for the section at 'a' where parabola and tooth profile are tangential to each other.

At point 'a', bending stress is

$$\sigma = \frac{Mc}{I} = \frac{6Fth}{bt^2} \quad (4.6)$$

By similar triangles,

$$\frac{t/2}{x} = \frac{h}{t/2} \text{ or } \frac{t^2}{h} = 4x \quad (4.7)$$

Substituting of Eqn. (4.7) in Eqn. (4.6), it gives

$$\sigma = \frac{6F_t}{4bx} \quad (4.8)$$

$$y = \frac{2x}{3p} \quad (4.9)$$

where 'y' is defined as the Lewis form factor .  
And substituting Eqn. (4.9) in Eqn. (4.8) we get

$$\sigma = \frac{F_t}{b p y} \quad (4.10)$$

**p π m** in equation (4.10), we get

$$\sigma = \frac{F_t}{b \pi y m} \quad (4.11)$$

Let  $Y = \pi y$ , which is known as modified Lewis form factor, then

$$\sigma = \frac{F_t}{b Y m} \quad (4.12)$$

Eqn. 12 is the standard Lewis equation for tooth bending stress based on module.

Both  $Y$  and  $y$  are functions of tooth shape (but not size) and therefore vary with the number of teeth in the gear. These values can be obtained from the below Table or Graph in below Fig.

**Table VALUES OF LEWIS FORM FACTOR**

<b>Number of teeth</b>	$\phi = 20^\circ$ $a = 0.8m^*$ $b = m$	$\phi = 20^\circ$ $a = m$ $b = 1.25m$	$\phi = 25^\circ$ $a = m$ $b = 1.25m$	$\phi = 25^\circ$ $a = m$ $b = 1.35m^+$
12	0.335 12	0.229 60	0.276 77	0.254 73
13	0.348 27	0.243 17	0.292 81	0.271 77
14	0.359 85	0.255 30	0.307 17	0.287 11
15	0.370 13	0.266 22	0.320 09	0.301 00
16	0.379 31	0.276 10	0.331 78	0.133 63
17	0.387 57	0.285 08	0.342 40	0.325 17
18	0.395 02	0.293 27	0.352 10	0.335 74
19	0.401 79	0.300 78	0.360 99	0.345 46
20	0.407 97	0.307 69	0.369 16	0.354 44
21	0.413 63	0.314 06	0.376 71	0.362 76
22	0.418 83	0.319 97	0.383 70	0.370 48
24	0.428 06	0.330 56	0.396 24	0.384 39
26	0.436 01	0.339 79	0.407 17	0.396 57
28	0.442 94	0.347 90	0.416 78	0.407 33
30	0.449 02	0.355 10	0.425 30	0.416 91
34	0.459 20	0.367 31	0.439 76	0.433 23
38	0.467 40	0.377 27	0.451 56	0.446 63
45	0.478 46	0.390 93	0.467 74	0.465 11
50	0.484 58	0.398 60	0.476 81	0.475 55
60	0.493 91	0.410 47	0.490 86	0.491 77
75	0.503 45	0.422 83	0.505 46	0.508 77
100	0.513 21	0.435 74	0.520 71	0.526 65
150	0.523 21	0.449 30	0.536 68	0.545 56
300	0.533 48	0.463 64	0.553 51	0.565 70
Rack	0.544 06	0.478 97	0.571 39	0.587 39

\* Stub teeth

+ Large fillet

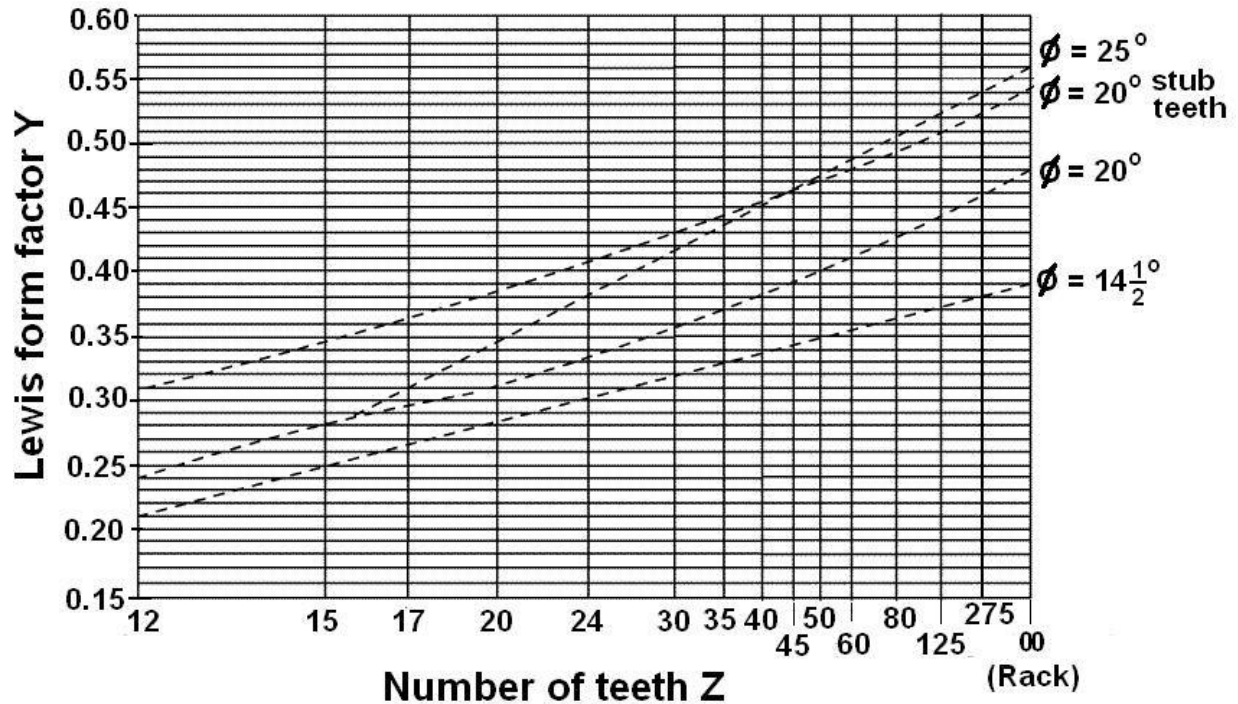

Fig. spur gear - graph 1 for modified Lewis form factor

The Lewis equation indicates that tooth bending stress varies with the following:

$$\sigma = \frac{F_t}{b Y m}$$

(4.13)

- (1) Directly with load,
- (2) Inversely with tooth width b,
- (3) Inversely with tooth size p or m,
- (4) Inversely with tooth shape factor y or Y.

Drawbacks of Lewis equation are:

1. The tooth load in practice is not static. It is dynamic and is influenced by pitch line velocity.
2. The whole load is carried by single tooth is not correct. Normally load is shared by teeth since contact ratio is near to 1.5.

3. The greatest force exerted at the tip of the tooth is not true as the load is shared by teeth. It is exerted much below the tip when single pair contact occurs.

4. The stress concentration effect at the fillet is not considered.

### SPUR GEAR – MODIFIED LEWIS EQUATION FOR BENDING STRESS

The modified Lewis equation for bending stress is,

$$\sigma = \frac{F_t}{K'_v b Y_m}$$

(4.14)

where  $K'_v$  is known as velocity factor and is given by Barth's equation below for known pitch line velocity  $V$  in m/s and is given by,

$$K'_v = \frac{6}{6 + V}$$

(4.15)

Eqn. (4.14) is used for cut or milled teeth or for gears not carefully generated.

$$K'_v = \frac{50}{50 + (200V)^{0.5}}$$

(4.16)

Eqn. (4.15) is used for hobbled and shaped gears.

$$K'_v = \left[ \frac{78}{78 + (200V)^{0.5}} \right]^{0.5}$$

(4.17)

Eqn. (4.16) is used for high-precision shaved or ground teeth.

The modified Lewis equation given in eqn. 4.13 is used when fatigue failure of the gear teeth is not a problem and a quick estimate is desired for more detailed analysis.

## SPUR GEAR - TOOTH BENDING STRESS

Factors that influence gear tooth bending stresses are as follows:

1. Pitch line velocity.
2. Manufacturing accuracy.
3. Contact ratio.
4. Stress concentration.
5. Degree of shock loading.
6. Accuracy and rigidity of mounting.
7. Moment of inertia of the gears and attached rotating Members.

### SPUR GEAR –TOOTH BENDING STRESS (AGMA)

Accommodating the earlier mentioned factors, American Gear Manufacturing Association (AGMA) came up with a refined form of Lewis equation as given below:

$$\sigma = \frac{F_t}{b m J} K_v K_o K_m \quad (4.18)$$

Where,  $J$  = Spur gear geometry factor. This factor includes the Lewis form factor  $Y$  and also a stress concentration factor based on a tooth fillet radius of  $0.35/P$ . It also depends on the number teeth in the mating gear.

$$J = \frac{Y}{K_f} \quad (4.19)$$

Where,  $Y$  is the modified Lewis form factor dealt earlier and  $K_f$  is the fatigue stress concentration factor given below:

$$K_f = H + \left(\frac{t}{r}\right)^L + \left(\frac{t}{l}\right)^M \quad (4.20)$$

Where,  $H = 0.34 - 0.458 366 2\phi$  (4.21)

$L = 0.316 - 0.458 366 2\phi$  (4.22)

$M = 0.290 + 0.458 366 2\phi$  (4.23)

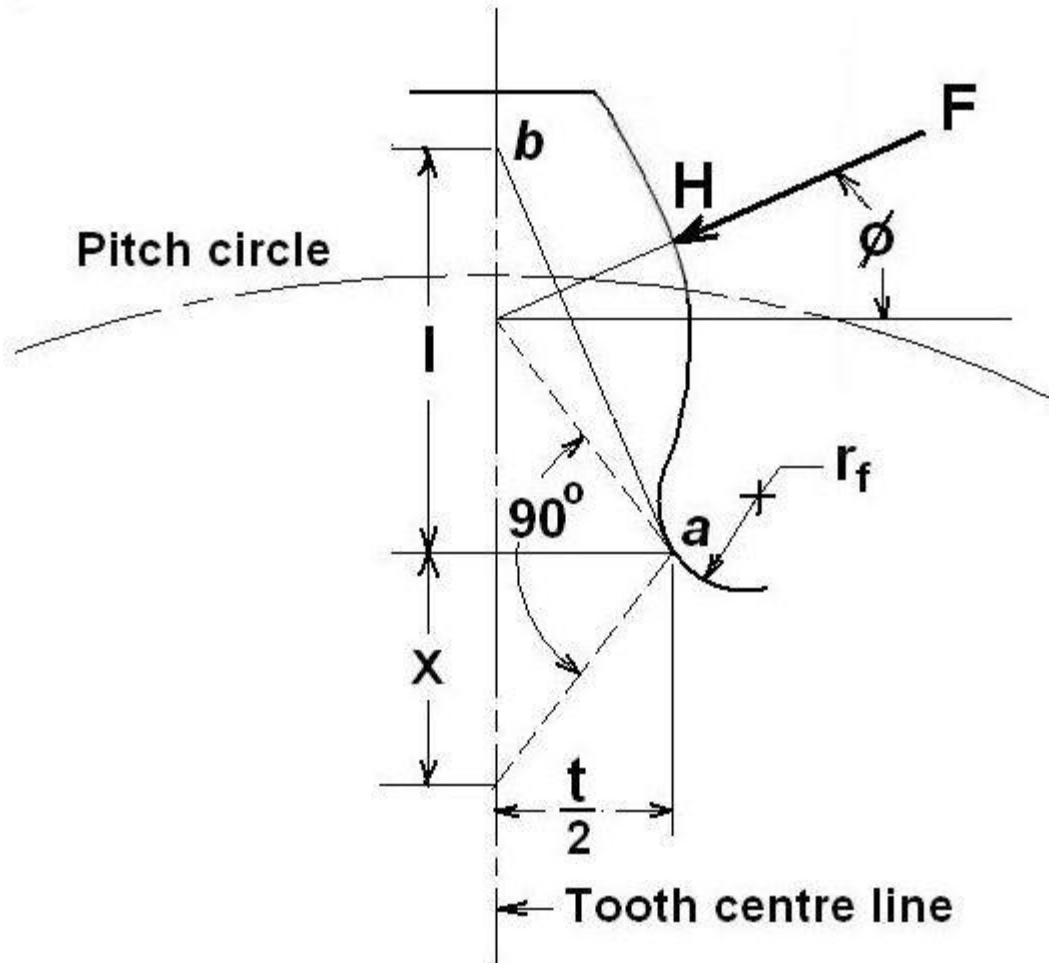

Fig. Maximum Tooth loading

$$r = \frac{r_f + (b - r_f)^2}{(d/2) + b - r_f}$$

(4.24)

Where,  $r_f$  is the fillet radius,  $d$  is the pitch diameter and  $b$  is the dedendum.

$J$  value can also be obtained from the Table 4.2 or Fig.4.5

Table 7.2 AGMA Geometry factor J for teeth having  $\Phi = 20^\circ$ ,  $a = 1m$ ,  $b = 1.25m$  and  $r = 0.3m_f$

Number of teeth	Number of teeth in mating gear							
	1	17	25	35	50	85	300	1000
18	0.244 86	0.324 04	0.332 14	0.338 40	0.344 04	0.350 50	0.355 94	0.361 12
19	0.247 94	0.330 29	0.338 78	0.345 37	0.351 34	0.358 22	0.364 05	0.369 63
20	0.250 72	0.336 00	0.344 85	0.351 76	0.358 04	0.365 32	0.371 51	0.377 49
21	0.253 23	0.341 24	0.350 44	0.357 64	0.364 22	0.371 86	0.378 41	0.384 75
22	0.255 52	0.346 07	0.355 59	0.363 06	0.369 92	0.377 92	0.384 79	0.391 48
24	0.259 51	0.354 68	0.364 77	0.372 75	0.380 12	0.388 77	0.396 26	0.403 60
26	0.262 89	0.362 11	0.372 72	0.381 15	0.388 97	0.398 21	0.406 25	0.414 18
28	0.265 80	0.368 60	0.379 67	0.388 51	0.396 73	0.406 50	0.415 04	0.423 51
30	0.268 31	0.374 62	0.385 80	0.395 00	0.403 59	0.413 83	0.422 83	0.431 79
34	0.272 47	0.383 94	0.396 71	0.405 94	0.415 17	0.426 24	0.436 04	0.445 86
38	0.275 75	0.391 70	0.404 46	0.414 80	0.424 56	0.436 33	0.446 80	0.457 35
45	0.280 13	0.402 23	0.415 79	0.426 85	0.437 35	0.450 10	0.461 52	0.473 10
50	0.282 52	0.408 08	0.422 08	0.435 55	0.444 48	0.457 78	0.469 75	0.481 93
60	0.286 13	0.417 02	0.431 73	0.443 83	0.455 42	0.469 60	0.482 43	0.495 57
75	0.289 79	0.426 20	0.441 63	0.454 40	0.466 68	0.481 79	0.495 54	0.509 70
100	0.293 53	0.435 61	0.451 80	0.465 27	0.478 27	0.494 37	0.509 09	0.524 35
150	0.297 38	0.445 30	0.462 26	0.476 45	0.490 23	0.507 36	0.523 12	0.539 54
300	0.301 41	0.455 26	0.473 04	0.487 98	0.502 56	0.520 78	0.537 65	0.555 33
Rack	0.305 71	0.465 54	0.484 15	0.499 88	0.515 29	0.534 67	0.552 72	0.571 73

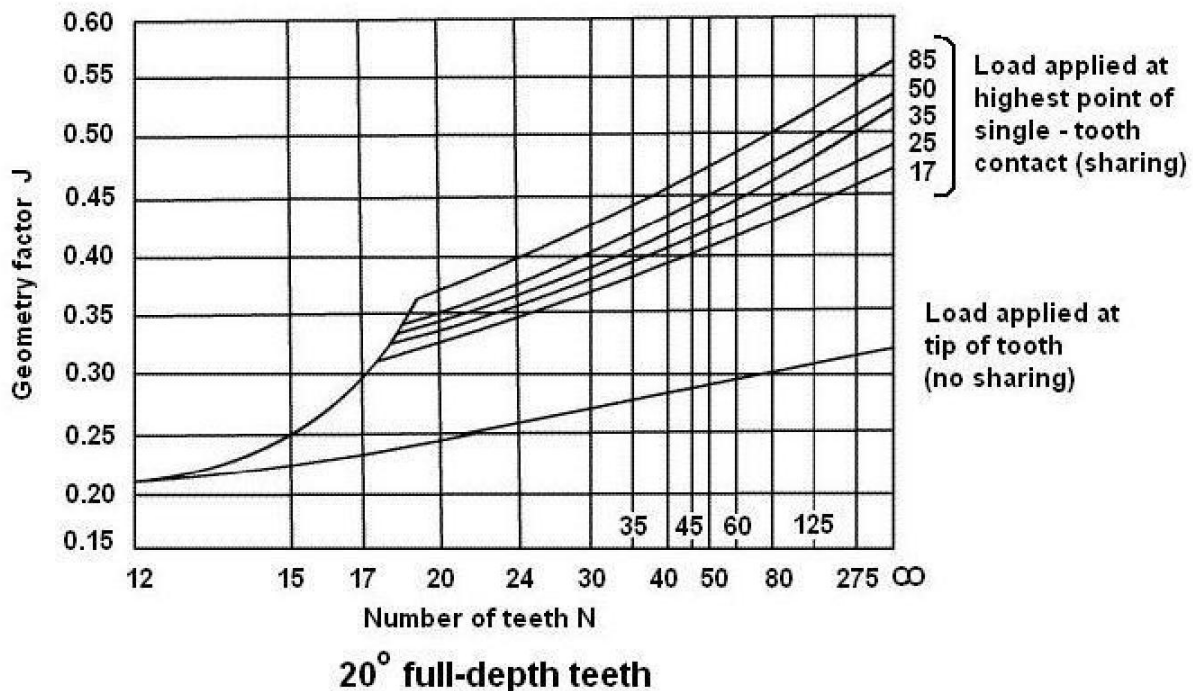

Fig. Graph 2 AGMA geometry (J) factor



$K_v$  - Velocity factor.

$K_o$  = overload factor, given in Table 4.3

$K_m$  = Load distribution factor, given in Table 4.4

$K_v$  = Velocity or dynamic factor, indicates the severity of impact as successive pairs of teeth engage. This is a function of pitch line velocity and manufacturing accuracy.

$$K_v = \frac{6 + V}{6}$$

(4.25)

Eqn. (4.25) is used for cut or milled teeth or for gears not carefully generated.

$$K_v = \frac{50 + (200V)^{0.5}}{50}$$

(4.26)

Eqn. (4.26) is used for hobbed and shaped gears.

$$K_v = \left[ \frac{78 + (200V)^{0.5}}{78} \right]^{0.5}$$

(4.27)

Eqn. (4.27) is used for high-precision shaved or ground teeth.

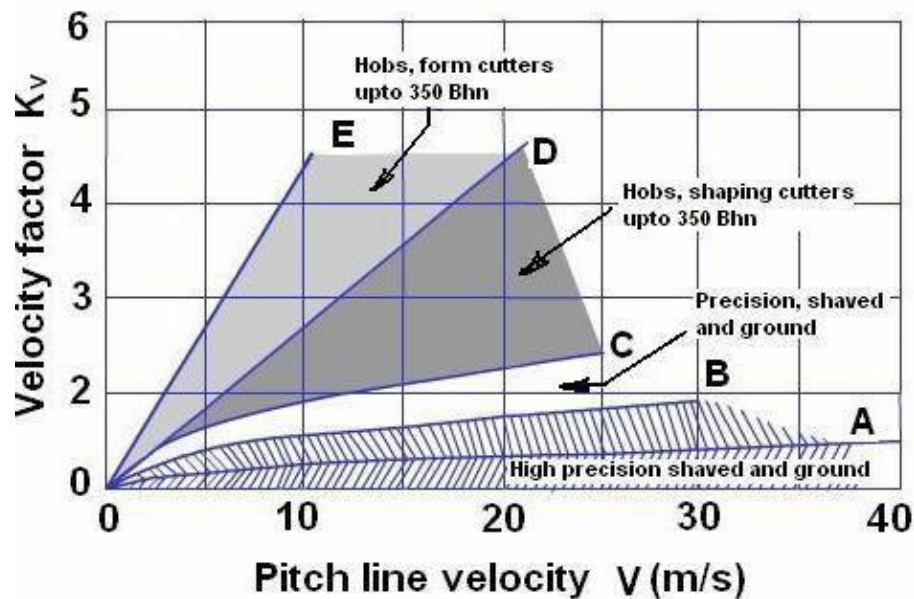

Rough value of  $K_v$  accounts for effects of tooth spacing and profile errors, tooth stiffness, and the velocity, inertia, and stiffness of the rotating parts.

Fig. Velocity factor  $K_v$

$K_o$  = Overload factor which reflects the degree of non-uniformity of driving and load torques. It is given in Table 7.3

$K_m$  = Load distribution factor which accounts for non-uniform spread of the load across the face width. It depends on the accuracy of mounting, bearings, shaft deflection and accuracy of gears.

**Table 4.3 -Overload factor  $K_o$**

	Driven Machinery		
Source of power	Uniform	Moderate Shock	Heavy Shock
Uniform	1.00	1.25	1.75
Light shock	1.25	1.50	2.00
Medium shock	1.50	1.75	2.25

**Table 4.4 Load distribution factor  $K_m$**

	Face width ( mm)			
Characteristics of Support	0 - 50	150	225	400 up
Accurate mountings, small bearing clearances, minimum deflection, precision gears	1.3	1.4	1.5	1.8
Less rigid mountings, less accurate gears, contact across the full face	1.6	1.7	1.8	2.2
Accuracy and mounting such that less than full-face contact exists	Over 2.2	Over 2.2	Over 2.2	Over 2.2

**SPUR GEAR – PERMISSIBLE TOOTH BENDING STRESS (AGMA)**

Endurance limit of the material is given by:

$$\sigma_e = \sigma_e' k_L k_v k_s k_r k_T k_f k_m \tag{4.28}$$

Where,  $\sigma_e'$  endurance limit of rotating-beam specimen

$k_L$  = load factor , = 1.0 for bending loads

$k_v$  = size factor, = 1.0 for  $m < 5$  mm and

= 0.85 for  $m > 5$  mm

$k_s$  = surface factor, is taken from Fig. 7.7 based on the ultimate tensile strength of the material for cut, shaved, and ground gears.

$k_r$  = reliability factor given in Table 7.5.

$k_T$  = temperature factor, = 1 for  $T \leq 350^\circ\text{C}$

= 0.5 for  $350 < T \leq 500^\circ\text{C}$

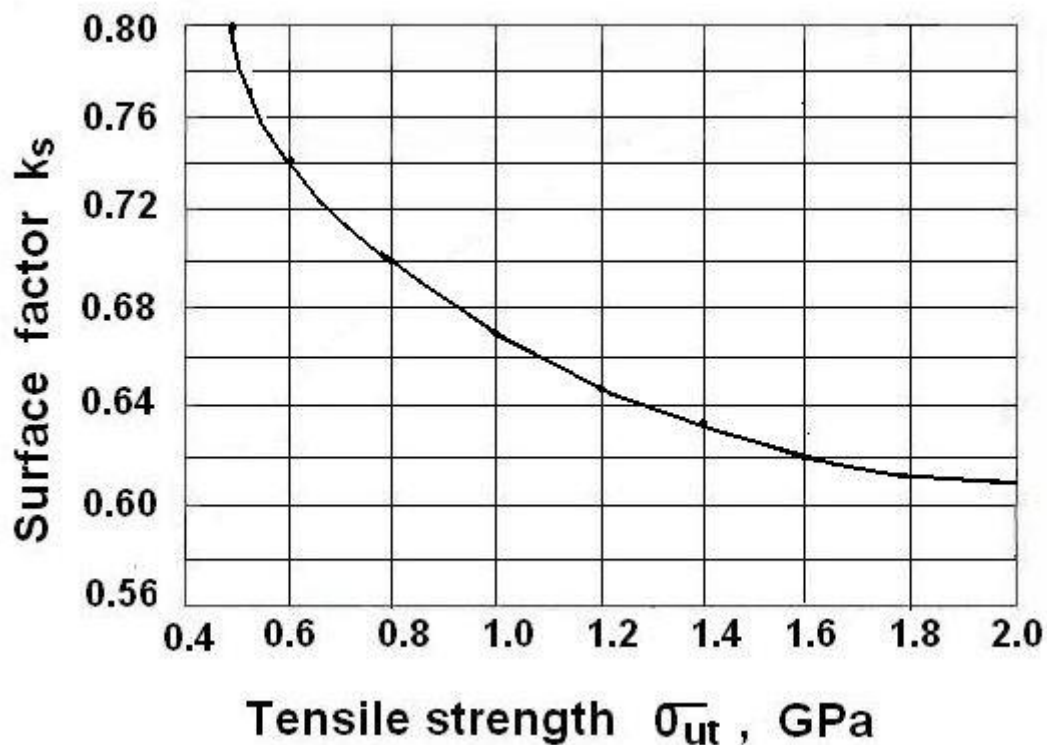

Fig. Surface factor  $k_s$   
Table 4.5 Reliability Factor  $k_r$

Reliability R	0.50	0.90	0.95	0.99	0.999	0.9999
Reliability Factor $k_r$	1.000	0.897	0.868	0.814	0.753	0.702

$k_f$  = fatigue stress concentration factor. Since this factor is included in J factor, its value is taken as 1.

$k_m$  = Factor for miscellaneous effects. For idler gears subjected to two way bending, = 1. For other gears subjected to one way bending, the value is taken from the Fig.7.8. Use  $k_m = 1.33$  for  $\sigma_{ut}$  less than 1.4 GPa.

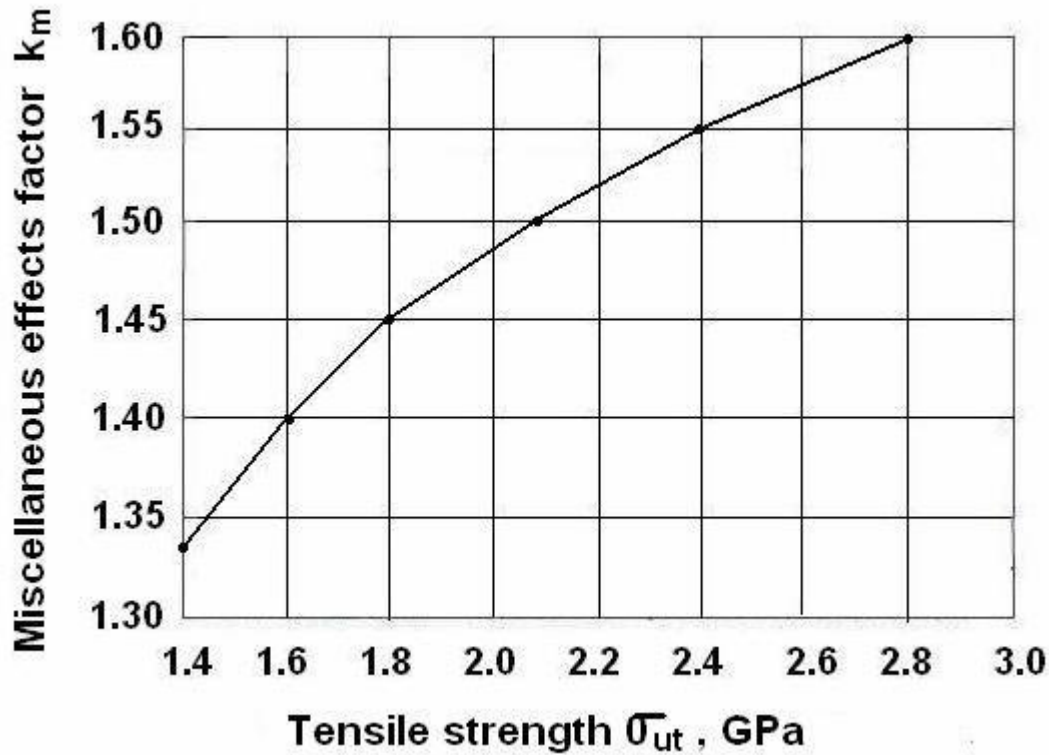

Fig. - Miscellaneous effects factor  $k_m$

Permissible bending stress

$$[\sigma] = \frac{\sigma_e}{s} \tag{4.29}$$

where  $s$  is the factor of safety.

Hence the design equation from bending consideration is :

$$\sigma \leq (\sigma_e / s) \tag{4.30}$$

### SPUR GEARS – BUCKINGHAM’S DYNAMIC LOAD EQUATION

#### Buckingham’s dynamic load equation (1932):

According to him, small machining error and deflection of teeth under load cause periods of acceleration, inertia forces, and impact loads on the teeth similar to variable load superimposed on a steady load. The total maximum instantaneous load on the teeth or dynamic load is  $F_d$

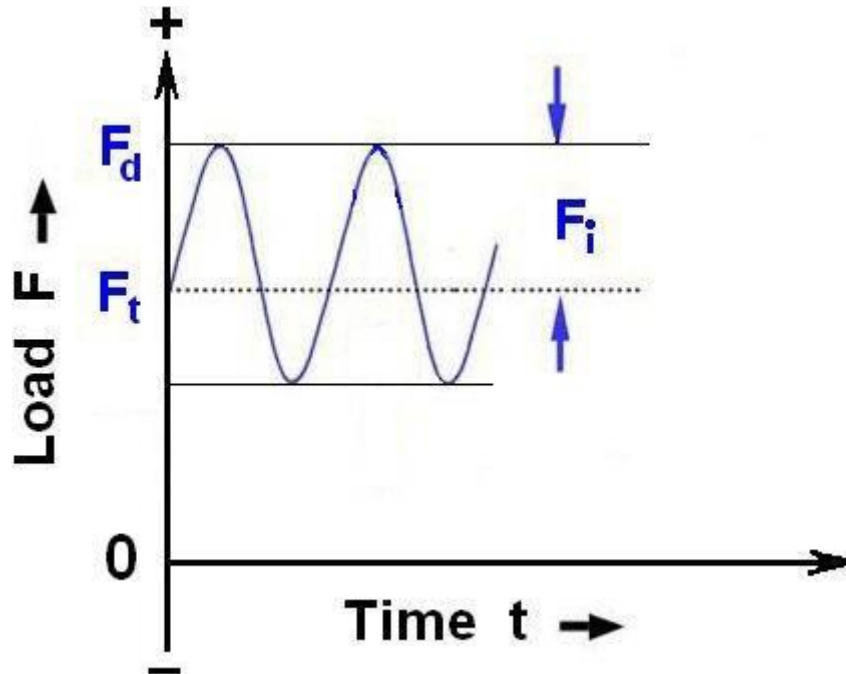

Fig. Dynamic loading on gear

$$F_d = F_t + F_i \quad (4.31)$$

$$F_i = \left[ \frac{9.84V(Cb + F_t)}{9.84V + 0.4696\sqrt{Cb + F_t}} \right]$$

(4.32)

Where

$F_d$  – Dynamic load, N

$F_t$  – Transmitted load, N

$F_i$  – Increment load due to machining errors and the pitch line velocity

$V$  – Pitch line velocity, m/s

$b$  – face width, mm

$C$  – Factor depending on machining error

Table 4.6 Value of C for spur gears

Tooth Form	Material of Pinion and gear	C
14.5°	Cast iron and Cast iron	5720 e
	Steel and Cast iron	7850 e
	Steel and Steel	11440 e
20° Full depth	Cast iron and Cast iron	5930 e
	Steel and Cast iron	8150 e
	Steel and Steel	11860 e
20° stub tooth	Cast iron and Cast iron	6150 e
	Steel and Cast iron	8450 e
	Steel and Steel	12300 e

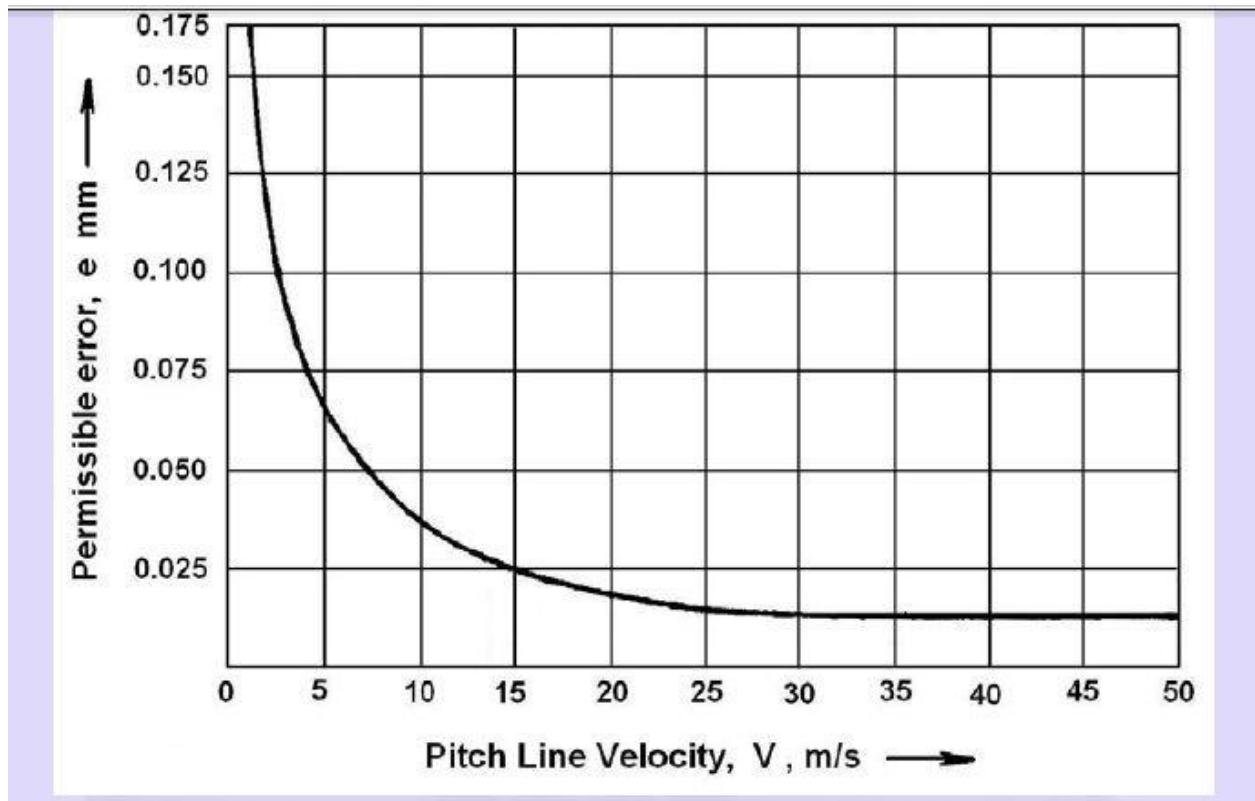

Fig. Graph 6 Permissible error

Table.7 Expected error in tooth profile

Module	Gear quality and expected error e		
	First class Commerical gears	Carefully cut gears	Precision gears
upto 4	0.050	0.025	0.0125
5	0.056	0.025	0.0125
6	0.064	0.030	0.0150
7	0.072	0.035	0.0170
8	0.080	0.038	0.0190
9	0.085	0.041	0.0205
10	0.090	0.044	0.0220

**SPUR GEARS –BUCKINGHAM’S DYNAMIC LOAD FOR DESIGN**

Lewis equation is,

$$\sigma = \frac{F_t}{b Y m}$$

(4.33)

Rearranging eqn 33,

$$F_t = \sigma b Y m \quad (4.34)$$

If we substitute permissible stress in Eqn. (4.33) we get on the right side, beam or tooth strength of the gear  $F_{td}$  as,

$$F_{td} = [\sigma] b Y m \quad (4.35)$$

From design point of view  $F_{td} = FF$

## Design of Shaft for Spur Gears

In order to find the diameter of shaft for spur gears, the following procedure may be followed.

1. First of all, find the normal load ( $W_N$ ), acting between the tooth surfaces. It is given by

$$W_N = W_T / \cos \phi$$

Where  $W_T$  = Tangential load, and  
 $\phi$  = Pressure angle.

A thrust parallel and equal to  $W_N$  will act at the gear centre as shown in Fig.

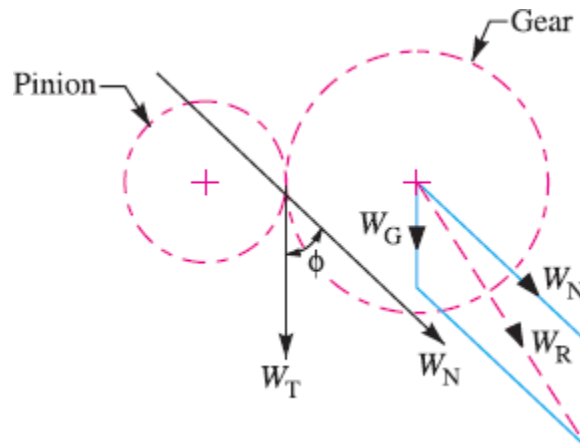

**Fig.** Load acting on the gear.

2. The weight of the gear is given by

$$W_G = 0.0018 TG.b.m^2 \text{ (in N)}$$

where  $TG$  = No. of teeth on the gear,  
 $b$  = Face width in mm, and  
 $m$  = Module in mm.

3. Now the resultant load acting on the gear,

$$W_R = \sqrt{(W_N)^2 + (W_G)^2 + 2 W_N \times W_G \cos \phi}$$

4. If the gear is overhung on the shaft, then bending moment on the shaft due to the resultant load,

$$M = W_R \times X$$

where  $X$  = Overhang i.e. the distance between the centre of gear and the centre of bearing.



5. Since the shaft is under the combined effect of torsion and bending, therefore we shall determine the equivalent torque. We know that equivalent torque,

$$T_e = \sqrt{M^2 + T^2}$$

$$T = \text{Twisting moment} = W_T \times D_G / 2$$

6. Now the diameter of the gear shaft ( $d$ ) is determined by using the following relation, *i.e.*

$$T_e = \frac{\pi}{16} \times \tau \times d^3$$

Where  $\tau$  = Shear stress for the material of the gear shaft.

**Note :** Proceeding in the similar way as discussed above, we may calculate the diameter of the pinion shaft.

### Design of Arms for Spur Gears

The cross-section of the arms is calculated by assuming them as a cantilever beam fixed at the hub and loaded at the pitch circle. It is also assumed that the load is equally distributed to all the arms. It may be noted that the arms are designed for the stalling load. The **stalling load** is a load that will develop the maximum stress in the arms and in the teeth. This happens at zero velocity, when the drive just starts operating.

The stalling load may be taken as the design tangential load divided by the velocity factor.

$$\text{Let } W_S = \text{Stalling load} = \frac{\text{Design tangential load}}{\text{Velocity factor}} = \frac{W_T}{C_v},$$

$D_G$  = Pitch circle diameter of the gear,

$n$  = Number of arms, and

$\sigma_b$  = Allowable bending stress for the material of the arms.

Now, maximum bending moment on each arm,

$$M = \frac{W_S \times D_G / 2}{n} = \frac{W_S \times D_G}{2n}$$

And the section modulus of arms for elliptical cross-section,

$$Z = \frac{\pi (a_1)^2 b_1}{32}$$

Where  $a_1$  = Major axis, and  $b_1$  = Minor axis.

The major axis is usually taken as twice the minor axis. Now, using the relation,  $b = M / Z$ , we can calculate the dimensions  $a_1$  and  $b_1$  for the gear arm at the hub end.

**Note:** The arms are usually tapered towards the rim about 1/16 per unit length of the arm (or radius of the gear).

$a_1$  Major axis of the section at the rim end

$$= a_1 - \text{Taper} = a_1 - \frac{1}{16} \times \text{Length of the arm} = a_1 - \frac{1}{16} \times \frac{D_G}{2} = a_1 - \frac{D_G}{32}$$

## Helical Gears

### 4.1 Introduction

A helical gear has teeth in form of helix around the gear. Two such gears may be used to connect two parallel shafts in place of spur gears. The helixes may be right handed on one gear and left handed on the other. The pitch surfaces are cylindrical as in spur gearing, but the teeth instead of being parallel to the axis, wind around the cylinders helically like screw threads. The teeth of helical gears with parallel axis have line contact, as in spur gearing. This provides gradual engagement and continuous contact of the engaging teeth. Hence helical gears give smooth drive with a high efficiency of transmission.

### 1.7.1 COMPARISON BETWEEN SPUR AND HELICAL GEARS

Table 1.3 Comparison Between Spur and Helical Gears

Spur Gears	Helical Gears
1. Teeth are cut parallel to the axis of the shaft.	1. Teeth are cut in the form of a helix on the pitch cylinder between meshing gears.
2. Contact between meshing teeth occurs along the entire face width of the tooth.	2. Contact between meshing gears begins with a point on the leading edge of the tooth and gradually extends along the diagonal line across the tooth.
3. Load application is sudden resulting into impact conditions and generating noise in high speed applications.	3. Pick up of load by the tooth is gradual, resulting in smooth engagement and quiet operation even at high speeds.
4. Used for parallel shafts only.	4. Crossed helical gears are used on shafts with crossed axes.
5. Speed is limited to about 20 m/s.	5. Used in automobiles, turbines and high speed applications upto 50 m/s.
6. Imposes radial load only.	6. Imposes radial and axial thrust loads.
7. Contact ratio is low.	7. Contact ratio is high.

### 4.2 Terms used in Helical Gears

The following terms in connection with helical gears, as shown in Fig. 4.1, are important from the subject point of view.

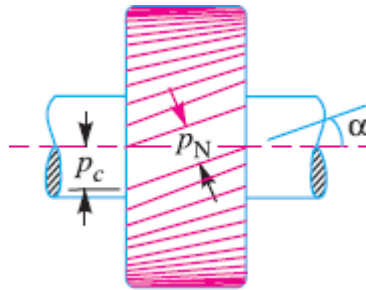

**Fig. 4.1.** Helical gear (Nomenclature).

1. **Helix angle.** It is a constant angle made by the helices with the axis of rotation.
2. **Axial pitch.** It is the distance, parallel to the axis, between similar faces of adjacent teeth. It is the same as circular pitch and is therefore denoted by  $p_c$ . The axial pitch may also be defined as the circular pitch in the plane of rotation or the diametral plane.
3. **Normal pitch.** It is the distance between similar faces of adjacent teeth along a helix on the pitch cylinders normal to the teeth. It is denoted by  $p_N$ . The normal pitch may also be defined as the circular pitch in the normal plane which is a plane perpendicular to the teeth. Mathematically, normal pitch,

$$P_N = P_c \cos \alpha$$

**Note :** If the gears are cut by standard hobs, then the pitch (or module) and the pressure angle of the hob will apply in the normal plane. On the other hand, if the gears are cut by the Fellows gear-shaper method, the pitch and pressure angle of the cutter will apply to the plane of rotation. The relation between the normal pressure angle ( $\phi_N$ ) in the normal plane and the pressure angle ( $\phi$ ) in the diametral plane (or plane of rotation) is given by

$$\tan \phi_N = \tan \phi \times \cos \alpha$$

### 4.3 Face Width of Helical Gears

In order to have more than one pair of teeth in contact, the tooth displacement (*i.e.* the advancement of one end of tooth over the other end) or overlap should be at least equal to the axial pitch, such that

$$\text{Overlap} = P_c = b \tan \alpha$$

$$\alpha \geq \frac{P_c}{b} \tag{i}$$

The normal tooth load ( $W_N$ ) has two components; one is tangential component ( $W_T$ ) and the other axial component ( $W_A$ ), as shown in Fig. 4.2. The axial or end thrust is given by

$$W_A = W_N \sin \alpha = W_T \tan \alpha$$

$$W_A = W_T \tan \alpha \tag{ii}$$

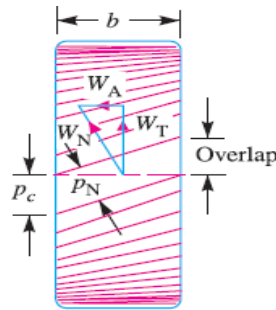

**Fig. 4.2.** Face width of helical gear.

From equation (i), we see that as the helix angle increases, then the tooth overlap increases. But at the same time, the end thrust as given by equation (ii), also increases, which is undesirable. It is usually recommended that the overlap should be 15 percent of the circular pitch.

$$\therefore \text{Overlap} = b \tan \alpha = 1.15 p_c$$

$$\text{or } b = \frac{1.15 p_c}{\tan \alpha} = \frac{1.15 \times \pi m}{\tan \alpha} \dots (\because p_c = \pi m)$$

where  $b$  = Minimum face width, and  
 $m$  = Module.

**Notes : 1.** The maximum face width may be taken as  $12.5 m$  to  $20 m$ , where  $m$  is the module. In terms of pinion diameter ( $D_p$ ), the face width should be  $1.5 D_p$  to  $2 D_p$ , although  $2.5 D_p$  may be used.

**2.** In case of double helical or herringbone gears, the minimum face width is given by

$$b = \frac{2.3 p_c}{\tan \alpha} = \frac{2.3 \times \pi m}{\tan \alpha}$$

The maximum face width ranges from  $20 m$  to  $30 m$ .

**3.** In single helical gears, the helix angle ranges from  $20^\circ$  to  $35^\circ$ , while for double helical gears, it may be made up to  $45^\circ$ .

### Formative or Equivalent Number of Teeth for Helical Gears

The formative or equivalent number of teeth for a helical gear may be defined as the number of teeth that can be generated on the surface of a cylinder having a radius equal to the radius of curvature at a point at the tip of the minor axis of an ellipse obtained by taking a section of the gear in the normal plane. Mathematically, formative or equivalent number of teeth on a helical gear,

$$T_E = T / \cos^3 \alpha$$

Where  $T$  = Actual number of teeth on a helical gear, and

$\alpha$  = Helix angle.

#### 4.5 Proportions for Helical Gears

Though the proportions for helical gears are not standardized, yet the following are recommended by American Gear Manufacturer's Association (AGMA).

Pressure angle in the plane of rotation,

$$\phi = 15^\circ \text{ to } 25^\circ$$

Helix angle,	$\alpha = 20^\circ \text{ to } 45^\circ$
Addendum	$= 0.8 m$ (Maximum)
Dedendum	$= 1 m$ (Minimum)
Minimum total depth	$= 1.8 m$
Minimum clearance	$= 0.2 m$
Thickness of tooth	$= 1.5708 m$



In helical gears, the teeth are inclined to the axis of the gear.

#### 4.6 Strength of Helical Gears

In helical gears, the contact between mating teeth is gradual, starting at one end and moving along the teeth so that at any instant the line of contact runs diagonally across the teeth.

Therefore in order to find the strength of helical gears, a modified Lewis equation is used. It is given by

where

$$W_T = (\sigma_o \times C_v) b \cdot \pi m \cdot y'$$

$W_T$  = Tangential tooth load,

$\sigma_o$  = Allowable static stress,

$C_v$  = Velocity factor,

$b$  = Face width,

$m$  = Module, and

$y'$  = Tooth form factor or Lewis factor corresponding to the formative or virtual or equivalent number of teeth.

**Notes : 1.** The value of velocity factor ( $C_v$ ) may be taken as follows :

$$\begin{aligned} C_v &= \frac{6}{6+v}, \text{ for peripheral velocities from } 5 \text{ m/s to } 10 \text{ m/s.} \\ &= \frac{15}{15+v}, \text{ for peripheral velocities from } 10 \text{ m/s to } 20 \text{ m/s.} \\ &= \frac{0.75}{0.75+\sqrt{v}}, \text{ for peripheral velocities greater than } 20 \text{ m/s.} \\ &= \frac{0.75}{1+v} + 0.25, \text{ for non-metallic gears.} \end{aligned}$$

**2.** The dynamic tooth load on the helical gears is given by

$$W_D = W_T + \frac{21v(b \cdot C \cos^2 \alpha + W_T) \cos \alpha}{21v + \sqrt{b \cdot C \cos^2 \alpha + W_T}}$$

where  $v$ ,  $b$  and  $C$  have usual meanings as discussed in spur gears.

**3.** The static tooth load or endurance strength of the tooth is given by

$$W_S = \sigma_e \cdot b \cdot \pi m \cdot y'$$

**4.** The maximum or limiting wear tooth load for helical gears is given by

$$W_w = \frac{D_p \cdot b \cdot Q \cdot K}{\cos^2 \alpha}$$

where  $D_p$ ,  $b$ ,  $Q$  and  $K$  have usual meanings as discussed in spur gears.

$$\text{In this case, } K = \frac{(\sigma_{es})^2 \sin \phi_N}{1.4} \left[ \frac{1}{E_p} + \frac{1}{E_G} \right]$$

where

$\phi_N$  = Normal pressure angle.

## WEAR

As per gear engineer's point of view, the wear is a kind of tooth damage where in layers of metal are removed more or less uniformly from the surface. It is nothing but progressive removal of metal from the surface. Consequently tooth thins down and gets weakened. Three most common causes of gear tooth wear are metal-to-metal contact due to lack of oil film, ingress of abrasive particles in the oil and chemical wear due to the composition of oil and its additives. Wear is classified as adhesive, abrasive and chemical wear.

## UNIT-5

### Power Screws

#### 5.1 Introduction

The power screws (also known as *translation screws*) are used to convert rotary motion into translatory motion. For example, in the case of the lead screw of lathe, the rotary motion is available but the tool has to be advanced in the direction of the cut against the cutting resistance of the material. In case of screw jack, a small force applied in the horizontal plane is used to raise or lower a large load. Power screws are also used in vices, testing machines, presses, etc.

In most of the power screws, the nut has axial motion against the resisting axial force while the screw rotates in its bearings. In some screws, the screw rotates and moves axially against the resisting force while the nut is stationary and in others the nut rotates while the screw moves axially with no rotation.

#### 5.2 Types of Screw Threads used for Power Screws

Following are the three types of screw threads mostly used for power screws:

1. **Square thread.** A square thread, as shown in Fig. 17.1 (a), is adapted for the transmission of power in either direction. This thread results in maximum efficiency and minimum radial or bursting

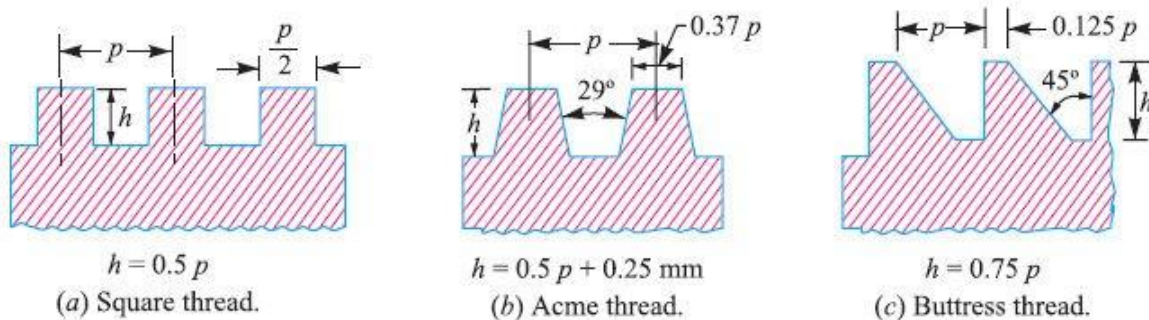

Fig. 5.1. Types of power screws.

Pressure on the nut. It is difficult to cut with taps and dies. It is usually cut on a lathe with a single point tool and it cannot be easily compensated for wear. The square threads are employed in screw jacks, presses and clamping devices. The standard dimensions for square threads according to IS: 4694 – 1968 (Reaffirmed 1996), are shown in Table 17.1 to 17.3.

2. **Acme or trapezoidal thread.** An acme or trapezoidal thread, as shown in Fig. 17.1 (b), is a modification of square thread. The slight slope given to its sides lowers the efficiency slightly than square thread and it also introduces some bursting pressure on the nut, but increases its area in shear. It is used where a split nut is required and where provision is made to take up wear as in the lead screw of a lathe. Wear may be taken up by means of an adjustable split nut. An acme thread may be cut by means of dies and hence it is more easily manufactured than square thread. The standard dimensions for acme or trapezoidal threads are shown in Table 17.4 (Page 630).

**3. Buttress thread.** A buttress thread, as shown in Fig. 5.1 (c), is used when large forces act along the screw axis in one direction only. This thread combines the higher efficiency of square thread and the ease of cutting and the adaptability to a split nut of acme thread. It is stronger than other threads because of greater thickness at the base of the thread. The buttress thread has limited use for power transmission. It is employed as the thread for light jack screws and vices.

### 5.3 Multiple Threads

The power screws with multiple threads such as double, triple etc. are employed when it is desired to secure a large lead with fine threads or high efficiency. Such type of threads are usually found in high speed actuators.

### 5.4 Torque Required to Raise Load by Square Threaded Screws

The torque required to raise a load by means of square threaded screw may be determined by considering a screw jack as shown in Fig. 5.2 (a). The load to be raised or lowered is placed on the head of the square threaded rod which is rotated by the application of an effort at the end of lever for lifting or lowering the load.

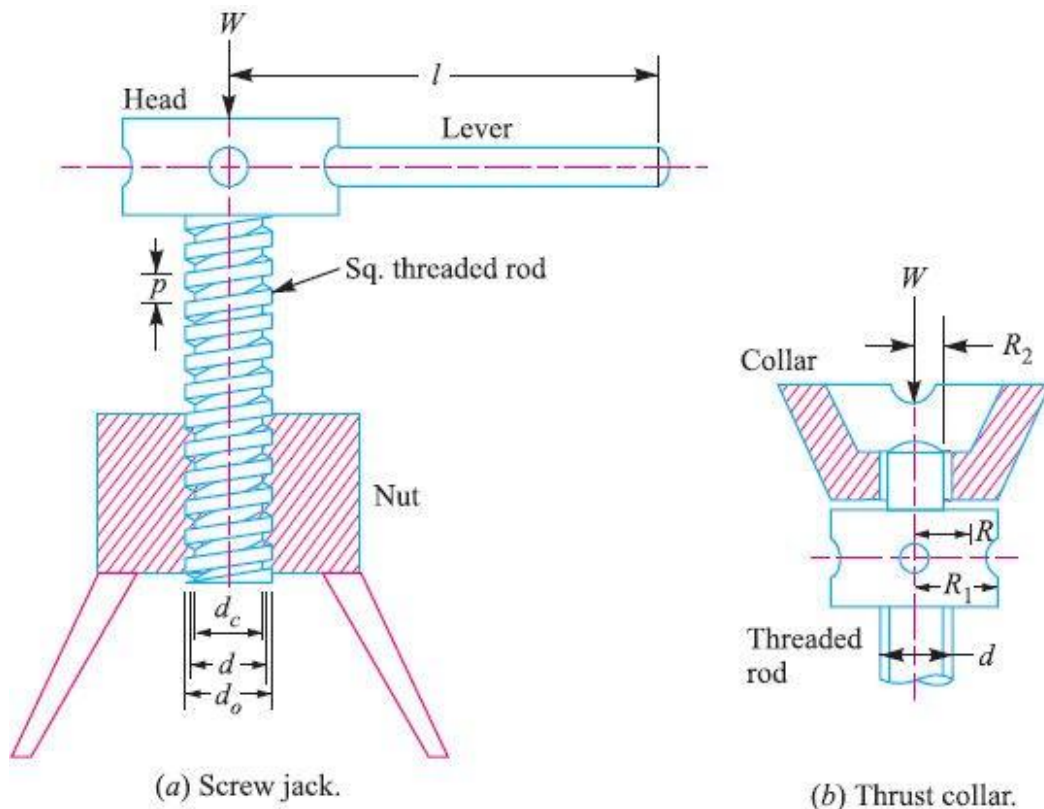
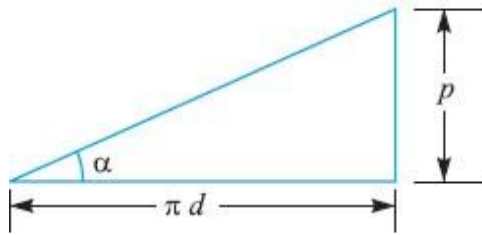

Fig. 17.2

A little consideration will show that if one complete turn of a screw thread be imagined to be unwound, from the body of the screw and developed, it will form an inclined plane as shown in Fig. 5.3 (a).





(a) Development of a screw.

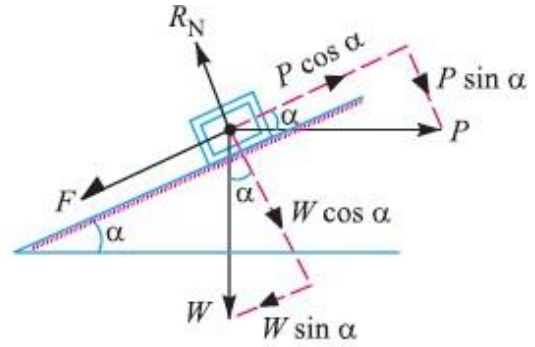

(b) Forces acting on the screw.

Fig. 5.3

- Let
- $p$  = Pitch of the screw,
  - $d$  = Mean diameter of the screw,
  - $\alpha$  = Helix angle,
  - $P$  = Effort applied at the circumference of the screw to lift the load,
  - $W$  = Load to be lifted, and
  - $\mu$  = Coefficient of friction, between the screw and nut
- =  $\tan \phi$ , where  $\phi$  is the friction angle.

From the geometry of the Fig. 5.3 (a), we find that

$$\tan \alpha = p / \pi d$$

Since the principle, on which a screw jack works is similar to that of an inclined plane, therefore the force applied on the circumference of a screw jack may be considered to be horizontal as shown in Fig. 5.3 (b).

Since the load is being lifted, therefore the force of friction ( $F = \mu \cdot R_N$ ) will act downwards. All the forces acting on the body are shown in Fig. 5.3 (b).

Resolving the forces along the plane,

$$P \cos \alpha = W \sin \alpha + F = W \sin \alpha + \mu \cdot R_N \dots\dots\dots (i)$$

and resolving the forces perpendicular to the plane,

$$R_N = P \sin \alpha + W \cos \alpha \dots\dots(ii)$$

Substituting this value of  $R_N$  in equation (i), we have

$$P \cos \alpha = W \sin \alpha + \mu (P \sin \alpha + W \cos \alpha)$$

$$= W \sin \alpha + \mu P \sin \alpha + \mu W \cos \alpha$$

or  $P \cos \alpha - \mu P \sin \alpha = W \sin \alpha + \mu W \cos \alpha$

or  $P (\cos \alpha - \mu \sin \alpha) = W (\sin \alpha + \mu \cos \alpha)$

$$\therefore P = W \times \frac{(\sin \alpha + \mu \cos \alpha)}{(\cos \alpha - \mu \sin \alpha)}$$

Substituting the value of  $\mu = \tan \phi$  in the above equation, we get

or 
$$P = W \times \frac{\sin \alpha + \tan \phi \cos \alpha}{\cos \alpha - \tan \phi \sin \alpha}$$

Multiplying the numerator and denominator by  $\cos \phi$ , we have

$$P = W \times \frac{\sin \alpha \cos \phi + \sin \phi \cos \alpha}{\cos \alpha \cos \phi - \sin \alpha \sin \phi}$$

$$= W \times \frac{\sin (\alpha + \phi)}{\cos (\alpha + \phi)} = W \tan (\alpha + \phi)$$

$\therefore$  Torque required to overcome friction between the screw and nut,

$$T_1 = P \times \frac{d}{2} = W \tan (\alpha + \phi) \frac{d}{2}$$

When the axial load is taken up by a thrust collar as shown in Fig. 5.2 (b), so that the load does not rotate with the screw, then the torque required to overcome friction at the collar,

$$T_2 = \frac{2}{3} \times \mu_1 \times W \left[ \frac{(R_1)^3 - (R_2)^3}{(R_1)^2 - (R_2)^2} \right] \quad \dots \text{(Assuming uniform pressure conditions)}$$

$$= \mu_1 \times W \left( \frac{R_1 + R_2}{2} \right) = \mu_1 W R \quad \dots \text{(Assuming uniform wear conditions)}$$

where

$R_1$  and  $R_2$  = Outside and inside radii of collar,

$R$  = Mean radius of collar =  $\frac{R_1 + R_2}{2}$ , and

$\mu_1$  = Coefficient of friction for the collar.

Total torque required to overcome friction (*i.e.* to rotate the screw),

$$T = T_1 + T_2$$

If an effort  $P$  is applied at the end of a lever of arm length  $l$ , then the total torque required to overcome friction must be equal to the torque applied at the end of lever, *i.e.*

$$T = P \times \frac{d}{2} = R_1 \times l$$

**Notes: 1.** When the \*nominal diameter ( $d_o$ ) and the \*\*core diameter ( $d_c$ ) of the screw is given, then

$$d = \frac{d_o + d_c}{2} = d_o - \frac{p}{2} = d_c + \frac{p}{2}$$

Mean diameter of screw,

2. Since the mechanical advantage is the ratio of the load lifted ( $W$ ) to the effort applied ( $P_1$ ) at the end of the lever, therefore mechanical advantage,

$$\begin{aligned} \text{M.A.} &= \frac{W}{P_1} = \frac{W \times 2l}{P \times d} && \dots \left( \because P \times \frac{d}{2} = P_1 \times l \text{ or } P_1 = \frac{P \times d}{2l} \right) \\ &= \frac{W \times 2l}{W \tan(\alpha + \phi) d} = \frac{2l}{d \tan(\alpha + \phi)} \end{aligned}$$

## 5.6 Efficiency of Square Threaded Screws

The efficiency of square threaded screws may be defined as the ratio between the ideal effort (*i.e.* the effort required to move the load, neglecting friction) to the actual effort (*i.e.* the effort required to move the load taking friction into account).

We have seen in Art. 17.4 that the effort applied at the circumference of the screw to lift the load is

$$P = W \tan(\alpha + \phi) \quad \dots(i)$$

where

$W$  = Load to be lifted,

$\alpha$  = Helix angle,

$\phi$  = Angle of friction, and

$\mu$  = Coefficient of friction between the screw and nut =  $\tan \phi$ .

If there would have been no friction between the screw and the nut, then  $\phi$  will be equal to zero.

The value of effort  $P_0$  necessary to raise the load, will then be given by the equation,

$$P_0 = W \tan \alpha \quad [\text{Substituting } \phi = 0 \text{ in equation (i)}]$$

$$\therefore \text{Efficiency, } \eta = \frac{\text{Ideal effort}}{\text{Actual effort}} = \frac{P_0}{P} = \frac{W \tan \alpha}{W \tan(\alpha + \phi)} = \frac{\tan \alpha}{\tan(\alpha + \phi)}$$

This shows that the efficiency of a screw jack, is independent of the load raised.

In the above expression for efficiency, only the screw friction is considered. However, if the screw friction and collar friction is taken into account, then

$$\begin{aligned} \eta &= \frac{\text{Torque required to move the load, neglecting friction}}{\text{Torque required to move the load, including screw and collar friction}} \\ &= \frac{T_0}{T} = \frac{P_0 \times d/2}{P \times d/2 + \mu_1 W R} \end{aligned}$$

**Note:** The efficiency may also be defined as the ratio of mechanical advantage to the velocity ratio. We know that mechanical advantage,

$$M.A. = \frac{W}{P_1} = \frac{W \times 2l}{P \times d} = \frac{W \times 2l}{W \tan(\alpha + \phi) d} = \frac{2l}{d \tan(\alpha + \phi)}$$

and velocity ratio,  $V.R. = \frac{\text{Distance moved by the effort } (P_1) \text{ in one revolution}}{\text{Distance moved by the load } (W) \text{ in one revolution}}$

$$= \frac{2\pi l}{p} = \frac{2\pi l}{\tan \alpha \times \pi d} = \frac{2l}{d \tan \alpha} \quad \dots (\because \tan \alpha = p / \pi d)$$

$$\therefore \text{Efficiency, } \eta = \frac{M.A.}{V.R.} = \frac{2l}{d \tan(\alpha + \phi)} \times \frac{d \tan \alpha}{2l} = \frac{\tan \alpha}{\tan(\alpha + \phi)}$$

### 5.7 Maximum Efficiency of a Square Threaded Screw

$$\eta = \frac{\tan \alpha}{\tan(\alpha + \phi)} = \frac{\sin \alpha / \cos \alpha}{\sin(\alpha + \phi) / \cos(\alpha + \phi)} = \frac{\sin \alpha \times \cos(\alpha + \phi)}{\cos \alpha \times \sin(\alpha + \phi)} \quad \dots (i)$$

Multiplying the numerator and denominator by 2, we have,

$$\eta = \frac{2 \sin \alpha \times \cos(\alpha + \phi)}{2 \cos \alpha \times \sin(\alpha + \phi)} = \frac{\sin(2\alpha + \phi) - \sin \phi}{\sin(2\alpha + \phi) + \sin \phi} \quad \dots (ii)$$

$$\left[ \begin{array}{l} \because 2 \sin A \cos B = \sin(A + B) + \sin(A - B) \\ \dots \\ 2 \cos A \sin B = \sin(A + B) - \sin(A - B) \end{array} \right]$$

The efficiency given by equation (ii) will be maximum when  $\sin(2\alpha + \phi)$  is maximum, i.e. when

$$\sin(2\alpha + \phi) = 1 \quad \text{or when } 2\alpha + \phi = 90^\circ$$

$$\therefore 2\alpha = 90^\circ - \phi \quad \text{or } \alpha = 45^\circ - \phi / 2$$

Substituting the value of  $2\alpha$  in equation (ii), we have maximum efficiency,

$$\eta_{max} = \frac{\sin(90^\circ - \phi + \phi) - \sin \phi}{\sin(90^\circ - \phi + \phi) + \sin \phi} = \frac{\sin 90^\circ - \sin \phi}{\sin 90^\circ + \sin \phi} = \frac{1 - \sin \phi}{1 + \sin \phi}$$

**Example 5.1.** A vertical screw with single start square threads of 50 mm mean diameter and 12.5 mm pitch is raised against a load of 10 kN by means of a hand wheel, the boss of which is threaded to act as a nut. The axial load is taken up by a thrust collar which supports the wheel boss and has a mean diameter of 60 mm. The coefficient of friction is 0.15 for the screw and 0.18 for the collar. If the tangential force applied by each hand to the wheel is 100 N, find suitable diameter of the hand wheel.

**Solution. Given :**  $d = 50 \text{ mm}$  ;  $p = 12.5 \text{ mm}$  ;  $W = 10 \text{ kN} = 10 \times 10^3 \text{ N}$  ;  $D = 60 \text{ mm}$  or  $R = 30 \text{ mm}$  ;  $\mu = \tan \phi = 0.15$  ;  $\mu_1 = 0.18$  ;  $P_1 = 100 \text{ N}$

We know that  $\tan \alpha = \frac{p}{\pi d} = \frac{12.5}{\pi \times 50} = 0.08$

and the tangential force required at the circumference of the screw,

$$P = W \tan (\alpha + \phi) = W \left( \frac{\tan \alpha + \tan \phi}{1 - \tan \alpha \tan \phi} \right)$$

$$= 10 \times 10^3 \left[ \frac{0.08 + 0.15}{1 - 0.08 \times 0.15} \right] = 2328 \text{ N}$$

We also know that the total torque required to turn the hand wheel,

$$T = P \times \frac{d}{2} + \mu_1 W R = 2328 \times \frac{50}{2} + 0.18 \times 10 \times 10^3 \times 30 \text{ N-mm}$$

$$= 58\,200 + 54\,000 = 112\,200 \text{ N-mm ... (i)}$$

Let  $D_1$  = Diameter of the hand wheel in mm.

We know that the torque applied to the handwheel,

$$T = 2 P_1 \times \frac{D_1}{2} = 2 \times 100 \times \frac{D_1}{2} = 100 D_1 \text{ N-mm} \quad \dots (ii)$$

Equating equations (i) and (ii),

$$D_1 = 112\,200 / 100 = 1122 \text{ mm} = 1.122 \text{ m Ans.}$$

### 5.8 Acme or Trapezoidal Threads

We know that the normal reaction in case of a square threaded screw is

$$R_N = W \cos \alpha$$

where  $\alpha$  is the helix angle.

But in case of Acme or trapezoidal thread, the normal reaction between the screw and nut is increased because the axial component of this normal reaction must be equal to the axial load ( $W$ ).

Consider an Acme or trapezoidal thread as shown in Fig. 5.6.

Let  $\theta$  = angle of the thread

\* The material of screw is usually steel and the nut is made of cast iron, gun metal, and phosphor bronze in order to keep the wear to a minimum.

\*\* For Acme threads,  $2\theta = 29^\circ$ , and for trapezoidal threads,  $2\theta = 30^\circ$ .

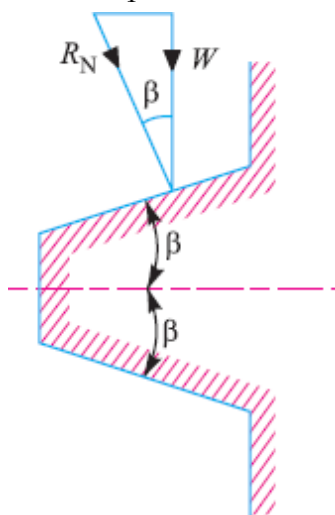

**Fig. 5.6.** Acme or trapezoidal threads.

$$\therefore R_N = \frac{W}{\cos \beta}$$

and frictional force,  $F = \mu \cdot R_N = \mu \times \frac{W}{\cos \beta} = \mu_1 \cdot W$

where  $\mu / \cos \beta = \mu_1$ , known as *virtual coefficient of friction*.

**Notes :** 1. When coefficient of friction,  $\mu_1 = \frac{\mu}{\cos \beta}$  is considered, then the Acme thread is equivalent to a square thread.

2. All equations of square threaded screw also hold good for Acme threads. In case of Acme threads,  $\mu_1$  (i.e.  $\tan \phi_1$ ) may be substituted in place of  $\mu$  (i.e.  $\tan \phi$ ). Thus for Acme threads,

$$P = W \tan (\alpha + \phi_1)$$

where  $\phi_1 =$  Virtual friction angle, and  $\tan \phi_1 = \mu_1$ .

**Example 17.6.** The lead screw of a lathe has Acme threads of 50 mm outside diameter and 8 mm pitch. The screw must exert an axial pressure of 2500 N in order to drive the tool carriage. The thrust is carried on a collar 110 mm outside diameter and 55 mm inside diameter and the lead screw rotates at 30 r.p.m. Determine (a) the power required to drive the screw; and (b) the efficiency of the lead screw. Assume a coefficient of friction of 0.15 for the screw and 0.12 for the collar.

**Solution.** Given:  $d_o = 50$  mm;  $p = 8$  mm;  $W = 2500$  N;  $D_1 = 110$  mm or  $R_1 = 55$  mm;  $D_2 = 55$  mm or  $R_2 = 27.5$  mm;  $N = 30$  r.p.m. ;  $\mu = \tan \phi = 0.15$  ;  $\mu_c = 0.12$

**(a) Power required to drive the screw**

We know that mean diameter of the screw,

$$d = d_o - p / 2 = 50 - 8 / 2 = 46 \text{ mm}$$

$$\therefore \tan \alpha = \frac{p}{\pi d} = \frac{8}{\pi \times 46} = 0.055$$

Since the angle for Acme threads is  $2\beta = 29^\circ$  or  $\beta = 14.5^\circ$ , therefore virtual coefficient of friction,

$$\mu_1 = \tan \phi_1 = \frac{\mu}{\cos \beta} = \frac{0.15}{\cos 14.5^\circ} = \frac{0.15}{0.9681} = 0.155$$

We know that the force required to overcome friction at the screw,

$$\begin{aligned} P &= W \tan (\alpha + \phi_1) = W \left[ \frac{\tan \alpha + \tan \phi_1}{1 - \tan \alpha \tan \phi_1} \right] \\ &= 2500 \left[ \frac{0.055 + 0.155}{1 - 0.055 \times 0.155} \right] = 530 \text{ N} \end{aligned}$$

and torque required to overcome friction at the screw.

$$T_1 = P \times d / 2 = 530 \times 46 / 2 = 12\,190 \text{ N-mm}$$

We know that mean radius of collar,

$$R = \frac{R_1 + R_2}{2} = \frac{55 + 27.5}{2} = 41.25 \text{ mm}$$

Assuming uniform wear, the torque required to overcome friction at collars,

$$T_2 = \square 2 W R = 0.12 \times 2500 \times 41.25 = 12\,375 \text{ N-mm}$$

□ Total torque required to overcome friction,

$$T = T_1 + T_2 = 12\,190 + 12\,375 = 24\,565 \text{ N-mm} = 24.565 \text{ N-m}$$

We know that power required to drive the screw

$$= T \cdot \omega = \frac{T \times 2 \pi N}{60} = \frac{24.565 \times 2 \pi \times 30}{60} = 77 \text{ W} = 0.077 \text{ kW} \quad \text{Ans.}$$

... ( $\because \omega = 2\pi N / 60$ )

### (b) Efficiency of the lead screw

We know that the torque required to drive the screw with no friction,

$$T_o = W \tan \alpha \times \frac{d}{2} = 2500 \times 0.055 \times \frac{46}{2} = 3163 \text{ N-mm} = 3.163 \text{ N-m}$$

$\therefore$  Efficiency of the lead screw,

$$\eta = \frac{T_o}{T} = \frac{3.163}{24.565} = 0.13 \text{ or } 13\% \quad \text{Ans.}$$

## 5.13 Stresses in Power Screws

A power screw must have adequate strength to withstand axial load and the applied torque.

Following types of stresses are induced in the screw.

**1. Direct tensile or compressive stress due to an axial load.** The direct stress due to the axial load may be determined by dividing the axial load ( $W$ ) by the minimum cross-sectional area of the screw ( $A_c$ ) *i.e.* area corresponding to minor or core diameter ( $d_c$ ). □ Direct stress (tensile or compressive)

$$= W/A$$

This is only applicable when the axial load is compressive and the unsupported length of the screw between the load and the nut is short. But when the screw is axially loaded in compression and the unsupported length of the screw between the load and the nut is too great, then the design must be based on column theory assuming suitable end conditions. In such cases, the cross-sectional area corresponding to core diameter may be obtained by using Rankine-Gordon formula or J.B. Johnson's formula. According to this,

$$W_{cr} = A_c \times \sigma_y \left[ 1 - \frac{\sigma_y}{4 C \pi^2 E} \left( \frac{L}{k} \right)^2 \right]$$

$$\therefore \sigma_c = \frac{W}{A_c} \left[ \frac{1}{1 - \frac{\sigma_y}{4 C \pi^2 E} \left( \frac{L}{k} \right)^2} \right]$$

Where  $W_{cr}$  = Critical load,

□<sub>y</sub> = Yield stress,

$L$  = Length of screw,

$k$  = Least radius of gyration,

$C$  = End-fixity coefficient,

$E$  = Modulus of elasticity, and

$\sigma_c$  = Stress induced due to load  $W$ .

**Note :** In actual practice, the core diameter is first obtained by considering the screw under simple compression and then checked for critical load or buckling load for stability of the screw.

**2. Torsional shear stress.** Since the screw is subjected to a twisting moment, therefore torsional shear stress is induced. This is obtained by considering the minimum cross-section of the screw. We know that torque transmitted by the screw,

$$T = \frac{\pi}{16} \times \tau (d_c)^3$$

or shear stress induced,

$$\tau = \frac{16 T}{\pi (d_c)^3}$$

When the screw is subjected to both direct stress and torsional shear stress, then the design must be based on maximum shear stress theory, according to which maximum shear stress on the minor diameter section,

$$\tau_{max} = \frac{1}{2} \sqrt{(\sigma_t \text{ or } \sigma_c)^2 + 4 \tau^2}$$

It may be noted that when the unsupported length of the screw is short, then failure will take place when the maximum shear stress is equal to the shear yield strength of the material. In this case,

Shear yield strength,

$$\tau_y = \tau_{max} \times \text{Factor of safety}$$

**3. Shear stress due to axial load.** The threads of the screw at the core or root diameter and the threads of the nut at the major diameter may shear due to the axial load. Assuming that the load is uniformly distributed over the threads in contact, we have Shear stress for screw,

$$\tau_{(screw)} = \frac{W}{\pi n . d_c . t}$$

and shear stress for nut,

$$\tau_{(nut)} = \frac{W}{\pi n . d_o . t}$$

Where

$W$  = Axial load on the screw,

$n$  = Number of threads in engagement,

$d_c$  = Core or root diameter of the screw,

$d_o$  = Outside or major diameter of nut or screw, and

$t$  = Thickness or width of thread.

**4. Bearing pressure.** In order to reduce wear of the screw and nut, the bearing pressure on the thread surfaces must be within limits. In the design of power screws, the bearing pressure depends upon the materials of the screw and nut, relative velocity between the nut and screw and the nature of lubrication. Assuming that the load is uniformly distributed over the threads in contact, the bearing pressure on the threads is given by



$$P_b = \frac{W}{\frac{\pi}{4} [(d_o)^2 - (d_c)^2] n} = \frac{*W}{\pi d . t . n}$$

where  $d$  = Mean diameter of screw,

$t$  = Thickness or width of screw =  $p / 2$ , and

$n$  = Number of threads in contact with the nut

$$= \frac{\text{Height of the nut}}{\text{Pitch of threads}} = \frac{h}{p}$$

Therefore, from the above expression, the height of nut or the length of thread engagement of the screw and nut may be obtained.

The following table shows some limiting values of bearing pressures.

$$* \quad \text{We know that } \frac{(d_o)^2 - (d_c)^2}{4} = \frac{d_o + d_c}{2} \times \frac{d_o - d_c}{2} = d \times \frac{p}{2} = d . t$$

**Example 17.7.** A power screw having double start square threads of 25 mm nominal diameter and 5 mm pitch is acted upon by an axial load of 10 kN. The outer and inner diameters of screw collar are 50 mm and 20 mm respectively. The coefficient of thread friction and collar friction may be assumed as 0.2 and 0.15 respectively. The screw rotates at 12 r.p.m. Assuming uniform wear condition at the collar and allowable thread bearing pressure of 5.8 N/mm<sup>2</sup>, find: 1. the torque required to rotate the screw; 2. the stress in the screw; and 3. the number of threads of nut in engagement with screw.

**Solution.** Given:  $d_o = 25$  mm;  $p = 5$  mm;  $W = 10$  kN =  $10 \times 10^3$  N;  $D_1 = 50$  mm or  $R_1 = 25$  mm;  $D_2 = 20$  mm or  $R_2 = 10$  mm;  $\mu = \tan \phi = 0.2$ ;  $\mu_1 = 0.15$ ;  $N = 12$  r.p.m.;  $p_b = 5.8$  N/mm<sup>2</sup>

### 1. Torque required to rotate the screw

We know that mean diameter of the screw,

$$d = d_o - p / 2 = 25 - 5 / 2 = 22.5 \text{ mm}$$

Since the screw is a double start square threaded screw, therefore lead of the screw,

$$= 2 p = 2 \times 5 = 10 \text{ mm}$$

$$\therefore \tan \alpha = \frac{\text{Lead}}{\pi d} = \frac{10}{\pi \times 22.5} = 0.1414$$

We know that tangential force required at the circumference of the screw,

$$P = W \tan (\alpha + \phi) = W \left[ \frac{\tan \alpha + \tan \phi}{1 - \tan \alpha \tan \phi} \right]$$

$$= 10 \times 10^3 \left[ \frac{0.1414 + 0.2}{1 - 0.1414 \times 0.2} \right] = 3513 \text{ N}$$

and mean radius of the screw collar,

$$R = \frac{R_1 + R_2}{2} = \frac{25 + 10}{2} = 17.5$$

\(\therefore\) Total torque required to rotate the screw,

$$T = P \times \frac{d}{2} + \mu_1 W R = 3513 \times \frac{22.5}{2} + 0.15 \times 10 \times 10^3 \times 17.5 \text{ N-mm}$$

$$= 65\,771 \text{ N-mm} = 65.771 \text{ N-m Ans.}$$

## 2. Stress in the screw

We know that the inner diameter or core diameter of the screw,

$$d_c = d_o - p = 25 - 5 = 20 \text{ mm}$$

□ Corresponding cross-sectional area of the screw,

$$A_c = \frac{\pi}{4} (d_c)^2 = \frac{\pi}{4} (20)^2 = 314.2 \text{ mm}^2$$

We know that direct stress,

$$\sigma_c = \frac{W}{A_c} = \frac{10 \times 10^3}{314.2} = 31.83 \text{ N/mm}^2$$

and shear stress,

$$\tau = \frac{16 T}{\pi (d_c)^3} = \frac{16 \times 65\,771}{\pi (20)^3} = 41.86 \text{ N/mm}^2$$

We know that maximum shear stress in the screw,

$$\tau_{max} = \frac{1}{2} \sqrt{(\sigma_c)^2 + 4\tau^2} = \frac{1}{2} \sqrt{(31.83)^2 + 4(41.86)^2}$$

$$= 44.8 \text{ N/mm}^2 = 44.8 \text{ MPa Ans.}$$

## 3. Number of threads of nut in engagement with screw

Let  $n$  = Number of threads of nut in engagement with screw, and

$t$  = Thickness of threads =  $p / 2 = 5 / 2 = 2.5 \text{ mm}$

we know that bearing pressure on the threads ( $p_b$ ),

$$5.8 = \frac{W}{\pi d \times t \times n} = \frac{10 \times 10^3}{\pi \times 22.5 \times 2.5 \times n} = \frac{56.6}{n}$$

$\therefore n = 56.6 / 5.8 = 9.76$  say 10 **Ans.**

$$P \cos \alpha = W \sin \alpha + \mu (P \sin \alpha + W \cos \alpha)$$

$$= W \sin \alpha + \mu P \sin \alpha + \mu W \cos \alpha$$

or  $P \cos \alpha - \mu P \sin \alpha = W \sin \alpha + \mu W \cos \alpha$

or  $P (\cos \alpha - \mu \sin \alpha) = W (\sin \alpha + \mu \cos \alpha)$

$$\therefore P = W \times \frac{(\sin \alpha + \mu \cos \alpha)}{(\cos \alpha - \mu \sin \alpha)}$$

Substituting the value of  $\mu = \tan \phi$  in the above equation, we get

or 
$$P = W \times \frac{\sin \alpha + \tan \phi \cos \alpha}{\cos \alpha - \tan \phi \sin \alpha}$$

Multiplying the numerator and denominator by  $\cos \phi$ , we have

$$P = W \times \frac{\sin \alpha \cos \phi + \sin \phi \cos \alpha}{\cos \alpha \cos \phi - \sin \alpha \sin \phi}$$

$$= W \times \frac{\sin (\alpha + \phi)}{\cos (\alpha + \phi)} = W \tan (\alpha + \phi)$$

$\therefore$  Torque required to overcome friction between the screw and nut,

$$T_1 = P \times \frac{d}{2} = W \tan (\alpha + \phi) \frac{d}{2}$$

\*\*\*\*\*