



INSTITUTE OF AERONAUTICAL ENGINEERING

(Autonomous)

Dundigal, Hyderabad -500 043

AERONAUTICAL ENGINEERING

COURSE LECTURE NOTES

Course Name	INTRODUCTION TO ROBOTICS
Course Code	AME553
Programme	B.Tech
Semester	VI
Course Coordinator	Mr. A Anudeep Kumar, Assistant Professor
Course Faculty	Mr. A Anudeep Kumar, Assistant Professor
Lecture Numbers	54
Topic Covered	All

COURSE OBJECTIVES (COs):

The course should enable the students to:	
I	Develop the knowledge in various robot structures and their workspace.
II	Develop the skills in performing kinematics analysis of robot systems.
III	Provide the knowledge of the dynamics associated with the operation of robotic systems.
IV	Provide the knowledge and analysis skills associated with trajectory planning.
V	Understand material handling and robot applications in industries.

COURSE LEARNING OUTCOMES (CLOs):

Students, who complete the course, will have demonstrated the ability to do the following:

AME553.01	Differentiate between automation and robotics.
AME553.02	Classify robots and describe its anatomy.
AME553.03	Specify various types of industrial sensors.
AME553.04	Classify various grippers.
AME553.05	Discuss about motion analysis of robot.
AME553.06	Understand methods for calculating the kinematics and inverse kinematics of a robot manipulator.
AME553.07	Deduce D-H notations, joint coordinates and. world coordinates.
AME553.08	Discuss about homogeneous transformation.
AME553.09	Describe the differential kinematics of planar manipulators.

AME553.10	Illustrate Lagrange-Euler formulation.
AME553.11	Discuss jacobian and robot dynamics.
AME553.12	Illustrate Newton-Euler formulation.
AME553.13	Describe Joint space scheme.
AME553.14	Illustrate cubic polynomial fit.
AME553.15	Classify types of motion.
AME553.16	Explain actuators and classify them.
AME553.17	Illustrate various robot applications in manufacturing.
AME553.18	Discuss the role of robots in material handling.
AME553.19	Explain work cell design.
AME553.20	Discuss the role of robots in assembly and inspection,

SYLLABUS

Unit-I	INTRODUCTION TO ROBOTICS
Introduction: Automation and robotic, an over view of robotics, classification by coordinate system and control systems; Components of the industrial robotics: Degrees of freedom, end effectors: Mechanical gripper, magnetic, vacuum cup and other types of grippers, general consideration on gripper selection and design.	
Unit-II	MOTION ANALYSIS AND KINEMATICS
Motion analysis: Basic rotation matrices, composite rotation matrices, Euler angles, equivalent angle and axis, homogeneous transformation, problems; Manipulator kinematics: D-H notations, joint coordinates and world coordinates, forward and inverse kinematics, problems.	
Unit-III	KINEMATICS AND DYNAMICS
Differential kinematics: Differential kinematics of planar and spherical manipulators, Jacobians, problems. Robot dynamics: Lagrange, Euler formulations, Newton-Euler formulations, problems on planar two link manipulators.	
Unit-IV	TRAJECTORY PLANNING AND ACTUATORS
Trajectory planning: Joint space scheme, cubic polynomial fit, avoidance of obstacles, types of motion: Slew motion, joint interpolated motion, straight line motion, problems, Robot actuators and feedback components; Actuators: pneumatic and hydraulic actuators.	
Unit-V	ELECTRIC ACTUATORS AND ROBOTIC APPLICATIONS
Electric actuators: DC servo motors, stepper motors, feedback components position sensors, potentiometers, resolvers and encoders, velocity sensors, tactile sensors. Robot application in manufacturing, material handling, assembly and inspection.	
Text Books:	
1. M. P. Groover, Industrial Robotics, Pearson, 2 nd Edition, 2012. 2. J.J Criag, Introduction to Robotic Mechanics and Controll, Pearson, 3 rd Edition, 2013.	
Reference Books:	
1. K.S Fu, Robotics, McGraw-Hill, 1 st Edition, 2013. 2. Richard, D.Klafter, Thomas A Chmielewski, Miachael Neigen, Robotic Engineering An Integrated Approach, Prentice Hall, 1 st Edition, 2013.	

UNIT-I
INTRODUCTION TO ROBOTICS

INTRODUCTION

The field of robotics has its origins in science fiction. The term robot was derived from the English translation of a fantasy play written in Czechoslovakia around 1920. It took another 40 years before the modern technology of industrial robotics began. Today Robots are highly automated mechanical manipulators controlled by computers. We survey some of the science fiction stories about robots, and we trace the historical development of robotics technology. Let us begin our chapter by defining the term robotics and establishing its place in relation to other types of industrial automation.

Robotics: -

Robotics is an applied engineering science that has been referred to as a combination of machine tool technology and computer science. It includes machine design, production theory, micro electronics, computer programming & artificial intelligence.

OR

"Robotics" is defined as the science of designing and building Robots which are suitable for real life application in automated manufacturing and other non-manufacturing environments.

Industrial robot: -

The official definition of an industrial robot is provided by the robotics industries association (RIA). Industrial robot is defined as an automatic, freely programmed, servo-controlled, multi-purpose manipulator to handle various operations of an industry with variable programmed motions.

Automation and robotics:-

Automation and robotics are two closely related technologies. In an industrial context, we can define automation as a technology that is concerned with the use of mechanical, electronic, and computer-based systems in the operation and control of production. Examples of this technology include transfer lines. Mechanized assembly machines, feedback control

systems (applied to industrial processes), numerically controlled machine tools, and robots. Accordingly, robotics is a form of industrial automation.

Ex:- Robotics, CAD/CAM, FMS, CIMS

Types of Automation:-

Automation is categorized into three types. They are,

- 1) Fixed Automation
- 2) Programmable Automation
- 3) Flexible Automation.

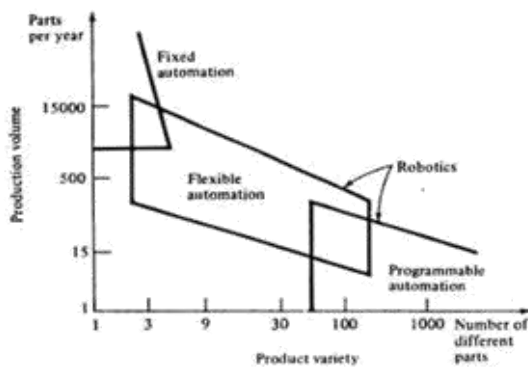

Relationship of fixed automation, programmable automation, and flexible automation as a function of production volume and product variety.

(1) Fixed Automation:-

It is the automation in which the sequence of processing or assembly operations to be carried out is fixed by the equipment configuration. In fixed automation, the sequence of operations (which are simple) are integrated in a piece of equipment. Therefore, it is difficult to automate changes in the design of the product. It is used where high volume of production is required. Production rate of fixed automation is high. In this automation, no new products are processed for a given sequence of assembly operations.

Features:-

- i) High volume of production rates,
- ii) Relatively inflexible in product variety (no new products are produced). Ex:- Automobile industries ... etc.

(2) Programmable Automation:-

It is the automation in which the equipment is designed to accommodate various product configurations in order to change the sequence of operations or assembly operations by means of control program. Different types of programs can be loaded into the equipment to produce products with new configurations (i.e., new products). It is employed for batch production of low and medium volumes. For each new batch of different configured product, a new control program corresponding to the new product is loaded into the equipment. This automation is relatively economic for small batches of the product.

Features:-

- i) High investment in general purpose,
 - ii) Lower production rates than fixed automation,
 - iii) Flexibility & Changes in products configuration,
 - iv) More suitable for batch production.
- Ex:- Industrial robot, NC machines tools... etc.

(3) Flexible Automation:-

A computer integrated manufacturing system which is an extension of programmable automation is referred as flexible automation. It is developed to minimize the time loss between the changeover of the batch production from one product to another while reloading. The program to produce new products and changing the physical setup i.e., it produces different products with no loss of time. This automation is more flexible in interconnecting work stations with material handling and storage system.

Features:-

- i) High investment for a custom engineering system.
- ii) Medium Production rates

- iii) Flexibility to deal with product design variation,
- iv) Continuous production of variable mixtures of products. Ex:- Flexible manufacturing systems (FMS)

Advantages:-

- 1.High Production rates
- 2.Lead time decreases
- 3.Storing capacity decreases
4. Human errors are eliminated.
- 5.Labour cost is decreases.

Disadvantages:-

- 1.Initial cost of raw material is very high,
- 2.Maintenance cost is high,
- 3.Required high skilled Labour.
4. Indirect cost for research development & programming increases.

Reasons for implementation of automated systems in manufacture industries:-

The reasons for the implementation of automated systems in manufacturing industries are as follows,

- (i) To Increase the Productivity Rate of Labour
- (ii) To Decrease the Cost of Labour
- (iii) To Minimize the Effect of Shortage of Labour
- (iv) To Obtain High Quality of Products

- (v) A Non-automation nigh Cost is Avoided
- (vi) To Decrease the Manufacturing Lead Time
- (vii) To upgrade the Safety of Workers.

Need for using robotics in industries:-

Industrial robot plays a significant role in automated manufacturing to perform different kinds of applications.

1. Robots can be built a performance capability superior to those of human beings. In terms of strength, size, speed, accuracy...etc.
2. Robots are better than humans to perform simple and repetitive tasks with better quality and consistence's.
3. Robots do not have the limitations and negative attributes of human works .such as fatigue, need for rest, and diversion of attention.....etc.
4. Robots are used in industries to save the time compared to human beings.
5. Robots are in value poor working conditions
6. Improved working conditions and reduced risks.

CAD/CAM & Robotics:-

CAD/CAM is a term which means computer aided design and computer aided manufacturing. It is the technology concerned with the use of digital computers to perform certain functions in design & production.

CAD:- CAD can be defined as the use of computer systems to assist in the creation modification, analysis OR optimization of design.

Cam:- CAM can be defined as the use of computer system to plan, manage & control the operation of a manufacturing plant, through either direct or in direct computer interface with the plant's production resources.

Specifications of robotics:-

1. Axil of motion
2. Work stations
3. Speed
4. Acceleration
5. Pay load capacity
6. Accuracy
7. Repeatability etc...

Overview of Robotics:-

"Robotics" is defined as the science of designing and building Robots which are suitable for real life application in automated manufacturing and other non-manufacturing environments. It has the following objectives,

1. To increase productivity
2. Reduce production life
3. Minimize labour requirement
4. Enhanced quality of the products
5. Minimize loss of man hours, on account of accidents.
6. Make reliable and high speed production.

The robots are classified as,

Programmable/Reprogrammable purpose

robots

*Tele-operated, Man controlled robots

*Intelligent robots.

Robots are used in manufacturing and assembly units

such as,

1. Spot or arc welding
2. Parts assembly
3. Paint spraying
4. Material, handling
5. Loading and unloading

The feature and capabilities of the robots are as follows,

1. Intelligence
2. Sensor capabilities
3. Telepresence
4. Mechanical design
5. Mobility and navigation
6. Universal gripper
7. System integration and networking.

Types of drive systems:-

1. Hydraulic drive
2. Electric drive
3. Pneumatic drive

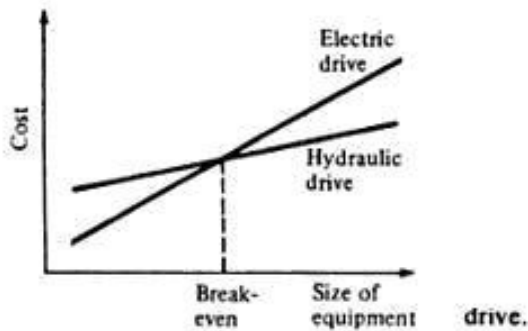

1. Hydraulic drive:-

Hydraulic drive and electric drive are the two main types of drives used on more sophisticated robots.

Hydraulic drive is generally associated with larger robots, such as the Unimate 2000 series. The usual advantages of the hydraulic drive system are that it provides the robot with greater speed and strength. The disadvantages of the hydraulic drive system are that it typically adds to the floor space required by the robot, and that a hydraulic system is inclined to leak on which is a nuisance.

This type of system can also be called as non-air powered cylinders. In this system, oil is used as a working fluid instead of compressed air. Hydraulic system need pump to generate the required pressure and flow rate. These systems are quite complex, costly and require maintenance.

2. Electric drive:-

Electric drive systems do not generally provide as much speed or power as hydraulic systems. However, the accuracy and repeatability of electric drive robots are usually better.

Consequently, electric robots tend to be smaller. Require less floor space, and their applications tend toward more precise work such as assembly.

In this System, power is developed by an electric current. It required little maintenance and the operation is noise less.

3. Pneumatic drive:-

Pneumatic drive is generally reserved for smaller robots that possess fewer degrees of freedom (two- to four-joint motions).

In this system, air is used as a working fluid, hence it is also called air-powered cylinders. Air is compressed in the cylinder with the aid of pump the compressed air is used to generate the power with required amount of pressure and flow rates.

Applications of robots:-

Present Applications of Robots:-

- (i) Material transfer applications
- (ii) Machine loading and unloading
- (iii) Processing operations like,
 - (a) Spot welding
 - (b) Continuous arc welding
 - (c) Spray coating
 - (d) Drilling, routing, machining operations
 - (e) Grinding, polishing debarring wire brushing
 - (g) Laser drilling and cutting etc.
- (iv) Assembly tasks, assembly cell designs, parts mating.

(v) Inspection, automation.

Future Applications of Robots:-

The profile of the future robot based on the research activities will include the following,

(i) Intelligence

(ii) Sensor capabilities

(iii) Telepresence

(iv) Mechanical design

(v) Mobility and navigation (walking machines)

(vi) Universal gripper

(vii) Systems and integration and networking

(viii) FMS (Flexible Manufacturing Systems)

(Ix) Hazardous and inaccessible non-manufacturing environments

(x) Underground coal mining

(xi) Fire fighting operations

(xii) Robots in space

(xiii) Security guards

(xiv) Garbage collection and waste disposal operations

(xv) Household robots

(xvi) Medical care and hospital duties etc.

Classification of Robots (or) Classification by co-ordinate system and control system:-

Co-ordinate systems:-

Industrial robots are available in a wide variety of sizes, shapes, and physical configurations. The vast majority of today's commercially available robots possess one of the basic configurations:

I. Polar configuration

2. Cylindrical configuration

3. Cartesian coordinate configurable

4. Jointed-arm configuration

1. Polar configuration:-

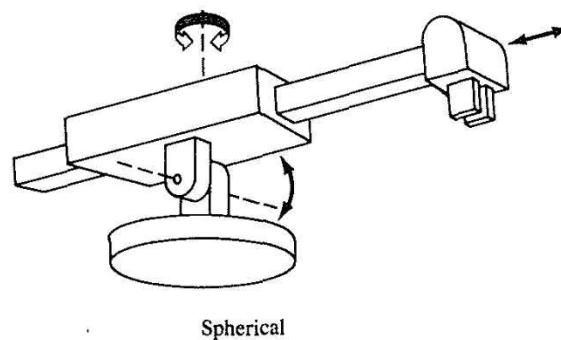

The polar configuration is pictured in part (a) of Fig. It uses a telescoping arm that can be raised or lowered about a horizontal pivot. The pivot is mounted on a rotating base. These various joints provide the robot with the capability to move its arm within a spherical space, and hence the name "spherical coordinate" robot is sometimes applied to this type. A number of commercial robots possess the polar configuration.

2. Cylindrical configuration:-

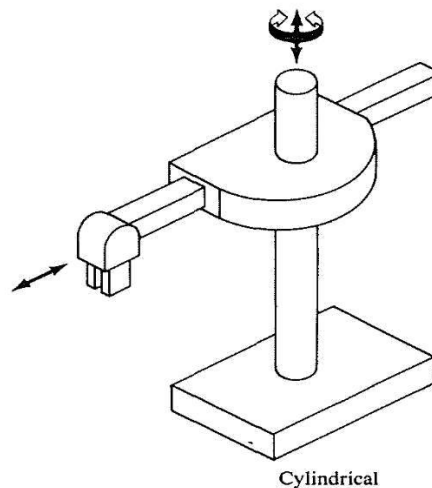

The cylindrical configurable, as shown in fig, uses a vertical column and a slide that can be moved up or down along the column. The robot arm is attached to the slide so that it can be moved radially with respect to the column. By rotating the column, the robot is capable of achieving a work space that approximates a cylinder.

3. Cartesian coordinate configurable:-

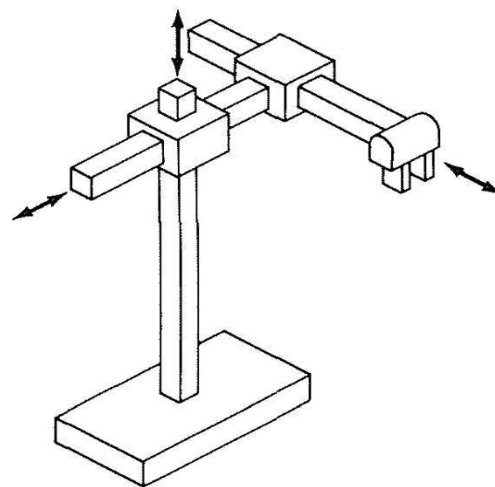

Cartesian or xyz

The cartesian coordinate robot, illustrated in part Cc) of Fig, uses three perpendicular slides to construct the x, y, and z axes. Other names are sometimes applied to this configuration, including xyz robot and rectilinear robot, By moving the three slides relative to one another, the robot is capable of operating within a rectangular work envelope.

4. Jointed-arm configuration:-

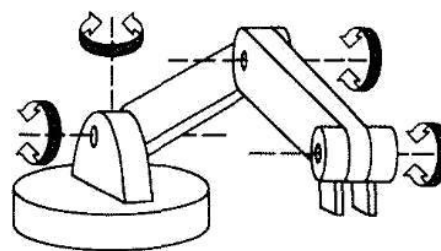

Revolute

The jointed-arm robot is pictured in Fig. Its configuration is similar to that of the human arm. It consists of two straight components. Corresponding to the human forearm and upper

arm, mounted on a vertical pedestal. These components are connected by two rotary joints corresponding to the shoulder and elbow.

Control systems:-

With respect to robotics, the motion control system used to control the movement of the end-effector or tool.

1. Limited sequence robots (Non-servo)
2. Playback robots with point to point (servo)
3. Playback robots with continuous path control,
4. Intelligent robots.

Limited sequence robots (Non-servo):-

Limited sequence robots do not give servo controlled to inclined relative positions of the joints; instead they are controlled by setting limit switches & are mechanical stops. There is generally no feedback associated with a limited sequence robot to indicate that the desired position, has been achieved generally this type of robots involves simple motion as pick & place operations.

Point to point motion:-

These type robots are capable of controlling velocity acceleration & path of motion, from the beginning to the end of the path. It uses complex control programs, PLC's (programmable logic controller's) computers to control the motion.

The point to point control motion robots are capable of performing motion cycle that consists of a series of desired point location. The robot is taught & recorded, unit.

Continuous path motion:-

In this robots are capable of performing motion cycle in which the path followed by the robot is controlled. The robot moves through a series of closely spaced points which describe the desired path.

Ex:- Spray painting, arc welding & complicate assembly operations.

Intelligent robots:-

This type of robots not only programmable motion cycle but also interact with its environment in a way that years intelligent. It taken make logical decisions based on sensor data receive from the operation.

There robots are usually programmed using an English like symbolic language not like a computer programming language.

Precision of movement (or) parameters of robot:-

The preceding discussion of response speed and stability is concerned with the dynamic performance of the robot. Another measure of performance is precision of the robot's movement. We will define precision as a function of three features:

- 1.Spatial resolution
- 2.Accuracy
- 3.Repeatability

These terms will be defined with the following assumptions.

- 1) The definitions will apply at the robot's wrist end with no hand attached to the wrist.
- 2) The terms apply to the worst case conditions, the conditions under which the robot's precision will be at its wont. This generally means that the robot's arm is fully extended in the case of a jointed arm or polar configurable.
- 3) Third, our definitions will he developed in the context of a point-to-point robot.

1. Spatial resolution:-

The spatial resolution of a robot is the smallest increment of movement into which the robot can divide its work volume. Spatial resolution depends on two factors: the

system's control resolution and the robot's mechanical inaccuracies. It is easiest to conceptualize these factors in terms of a robot with 1 degree of freedom.

2. Accuracy:-

Accuracy refers to a robot's ability to position its wrist end at a desired target point within the work volume. The accuracy of a robot can be defined in terms of spatial resolution because the ability to achieve a given target point depends on how closely the robot can define the control increments for each of its joint motions.

3. Repeatability:-

Repeatability is concerned with the robot's ability to position its wrist or an end effector attached to its wrist at a point in space is known as repeatability. Repeatability and accuracy refer to two different aspects of the robot's precision. Accuracy relates to the robot's capacity to be programmed to achieve a given target point. The actual programmed point will probably be different from the target point due to limitations of control resolution. Repeatability refers to the robot's ability to return to the programmed point when commanded to do so.

UNIT-II
MOTION ANALYSIS AND KINEMATICS

ROBOT KINEMATICS

INTRODUCTION:

A robot is a machine capable of doing work by using different physical motions called mechanism. Various types of mechanism are used for generating robotic motion. A robot mechanism is a multi-link system. We know that the combination of links is called linkage. The linkage (joint) can be described by the way the pair of links are connected to each other.

There are two types of connections between the pair of links. Refer Fig. 2.1(a) and (b)

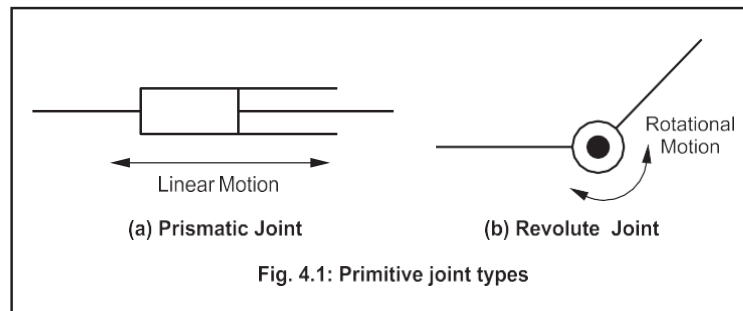

Prismatic joint: One link slides on the other along a straight line Linear motion.

Revolute joint: Here, the pair of links rotate about a fixed axis like a link rotates about a hinge Rotational motion. Most of the robots are built with the combination of the above two types of joints.

The two joints are shown in Fig. 2.2 Normally each joint represents 1 degree of freedom (DOF). In this Fig. 2.2, there are 6 joints -5 revolute joints and 1 prismatic joint. So there are 6 degrees of freedom (6 DOF). i.e. 6 is the minimum number of parameters required to position the end effector. For dynamic systems, velocity should be added to each DOF.

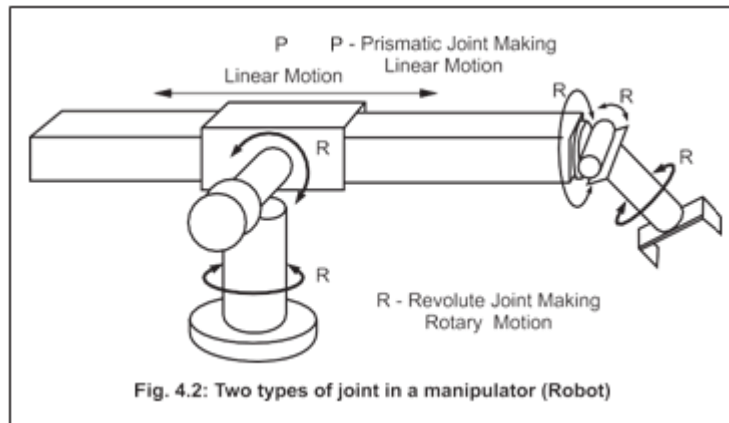

Refer Fig. 2.3. Joints are labelled as J_1 and J_2 . Links are labelled as L_1 , L_2 and L_3 .

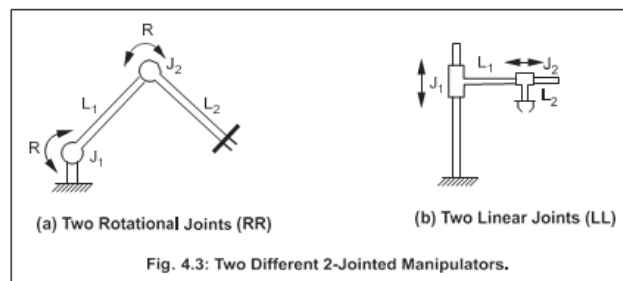

FORWARD KINEMATICS AND REVERSE (INVERSE) KINEMATICS:

If the position and orientation of the end effector are derived from the given joint angles (θ_1, θ_2) and link parameters L_1, L_2 then the way is called forward kinematics. Fig. 2.4.

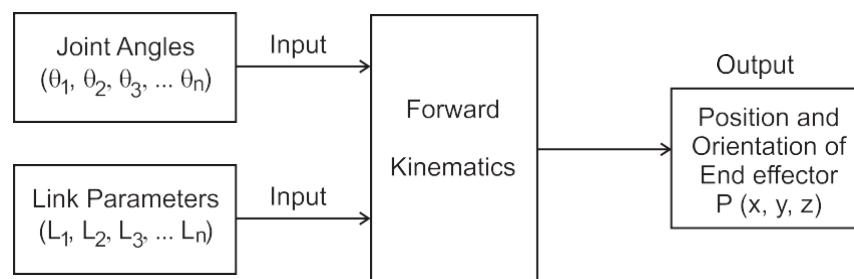

Fig. 2.4: Forward Kinematics

On the other hand, if the joint angles ($\theta_1, \theta_2, \dots$) and link parameters (L_1, L_2, \dots) of the robot are derived from the position and orientation of the end effector, then the way is called the Reverse kinematics (or) Inverse kinematics Fig. 2.5.

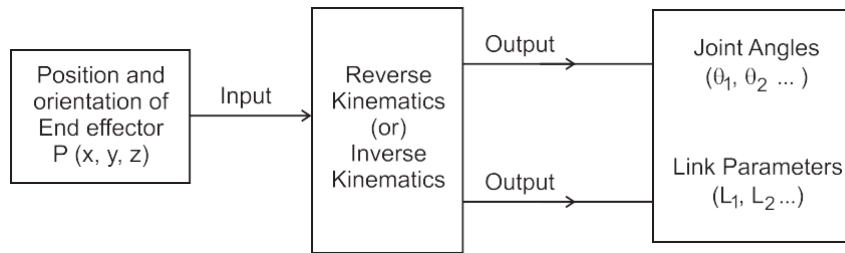
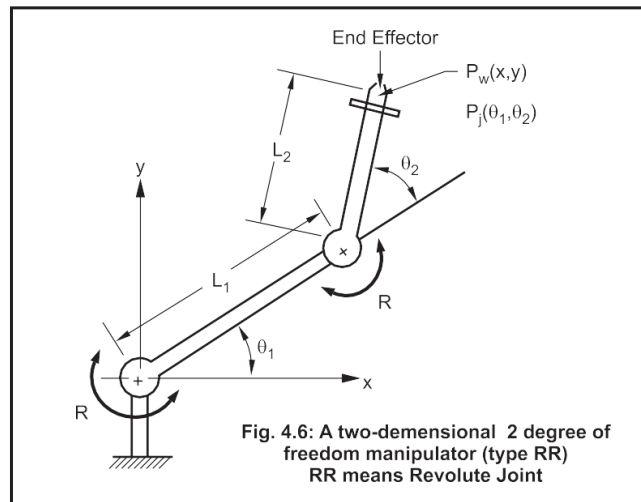

Fig. 2.5: Reverse (Inverse) Kinematics

Refer Fig. 2.6. The position of end effector can be represented by two ways



One way → using two joint angles θ_1 and θ_2 .

It is known as **'Joint space'**.

$$P_j = (\theta_1, \theta_2)$$

Another way ® defining the end effector position in **'World space'** using Cartesian coordinate system.

$$P_w = (x, y) \text{ in 2D}$$

$$P_w = (x, y, z) \text{ in 3D}$$

Among these two ways, world space is the best way to understand the Robot's kinematics.

In forward kinematics, the world space $P_w(x, y)$ is found out by using joint space $P_j(\theta_1, \theta_2)$.

In reverse kinematics, the joint space $P_j(\theta_1, \theta_2)$, is found out by using world space $P_w(x, y)$.

FORWARD KINEMATIC OF MANIPULATORS WITH 2 DOF IN 2D:

For link 1, $x_1 = L_1 \cos \theta_1$

$$y_1 = L_1 \sin \theta_1$$

Position of Link 1, $r_1(x_1, y_1) = [L_1 \cos \theta_1, L_1 \sin \theta_1]$

Similarly for Link 2, $r_2(x, y) = [L_2 \cos (\theta_1 + \theta_2), L_2 \sin (\theta_1 + \theta_2)]$

i.e., $r_1 = L_1 \cos \theta_1, L_1 \sin \theta_1$

$$r_2 = L_2 \cos (\theta_1 + \theta_2), L_2 \sin (\theta_1 + \theta_2)$$

Adding vectorially, we can get the coordinates x and y of the manipulator end effector P_w in world space, as

$$x_2 = L_1 \cos \theta_1 + L_2 \cos (\theta_1 + \theta_2) \dots (1)$$

$$y_2 = L_1 \sin \theta_1 + L_2 \sin (\theta_1 + \theta_2) \dots (2)$$

REVERSE KINEMATICS OF MANIPULATORS WITH 2 DOF IN 2D:

In this case, the joint angles are derived from the position in world space of end effector.

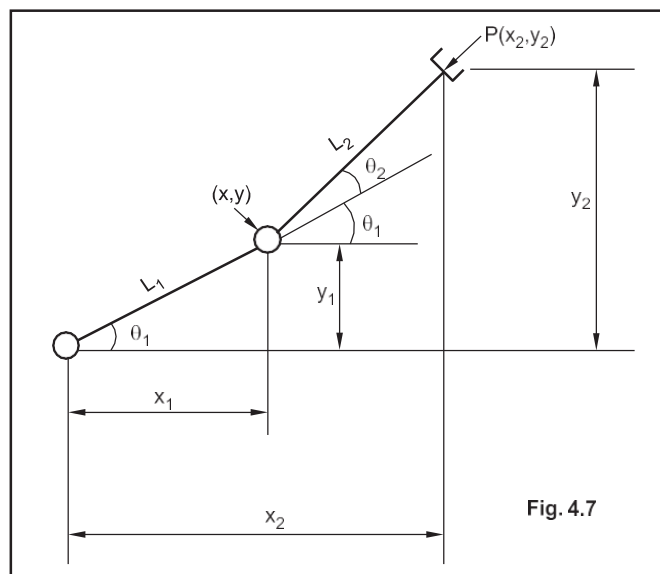

We know,

$$\cos (A + B) = \cos A \cos B - \sin A \sin B$$

$$\sin (A + B) = \sin A \cos B + \cos A \sin B$$

Now the equations 1 and 2 can be expanded as

$$x_2 = L_1 \cos \theta_1 + L_2 \cos \theta_1 \cos \theta_2 - L_2 \sin \theta_1 \sin \theta_2 \dots\dots\dots (3)$$

$$y_2 = L_1 \sin \theta_1 + L_2 \sin \theta_1 \cos \theta_2 + L_2 \cos \theta_1 \sin \theta_2 \dots\dots\dots (4)$$

Squaring on both sides and adding the two equations, we get

$$\cos \theta_2 = \frac{x^2 + y^2 - L_1^2 - L_2^2}{2 L_1 L_2}$$

Substituting value of θ_2 in equations (3) and (4), we can get θ_1 .

FORWARD KINEMATICS OF MANIPULATORS WITH 3 DOF IN 2D:

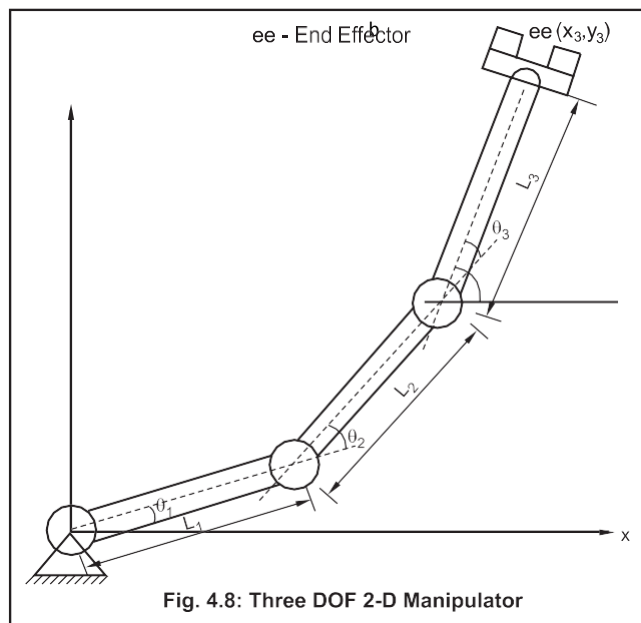

In the forward kinematics, to find out the position of the end effector, we have to construct the different transformation matrices and combine them. The result being ${}^{bs}{}^{ee}T$, where bs is the base frame of the robot manipulator and ee is end effector.

This can be done by the use of the Denavit-Hartenberg convention.

Thus the compound homogeneous transformation matrix is found by premultiplying the individual transformation matrices.

$${}^{ee}T = {}^N T = {}^0 T {}^1 T {}^2 T {}^3 T \dots\dots$$

ee – end effector,

bs – base.

L_1, L_2, L_3 are the lengths of the arm, $\theta_1, \theta_2, \theta_3$ are the twisted angles respectively.

The orientation of the first link, relative to the reference frame is given by

$$T_1(\theta_1) = \begin{bmatrix} \cos \theta_1 & -\sin \theta_1 & 0 \\ \sin \theta_1 & -\cos \theta_1 & 0 \\ 0 & 0 & 1 \end{bmatrix}$$

The orientation of the second link relative to the first link is given by

$$T_2(\theta_2) = \begin{bmatrix} \cos \theta_2 & -\sin \theta_2 & L_1 \\ \sin \theta_2 & -\cos \theta_2 & 0 \\ 0 & 0 & 1 \end{bmatrix}$$

This corresponds to a rotation by an angle θ_2 and translation by a distance L_1 (L_1 = Length of the first link).

The orientation of the third link, relative to the second link is given by

$$T_3(\theta_3) = \begin{bmatrix} \cos \theta_3 & -\sin \theta_3 & L_2 \\ \sin \theta_3 & -\cos \theta_3 & 0 \\ 0 & 0 & 1 \end{bmatrix}$$

The position of the end effector, relative to the third link is given by

$$T_4 = \begin{bmatrix} 1 & 0 & L_3 \\ 0 & 1 & 0 \\ 0 & 0 & 1 \end{bmatrix}$$

Then solution by Denavit – Hartenberg Convention.

$${}^{00}T_{bs} = {}_0^4 T$$

$$= \begin{bmatrix} \cos \theta_1 & -\sin \theta_1 & 0 \\ \sin \theta_1 & -\cos \theta_1 & 0 \\ 0 & 0 & 1 \end{bmatrix} \begin{bmatrix} \cos \theta_2 & -\sin \theta_2 & L_1 \\ \sin \theta_2 & -\cos \theta_2 & 0 \\ 0 & 0 & 1 \end{bmatrix} \begin{bmatrix} \cos \theta_3 & -\sin \theta_3 & L_2 \\ \sin \theta_3 & -\cos \theta_3 & 0 \\ 0 & 0 & 1 \end{bmatrix} \begin{bmatrix} 1 & 0 & L_3 \\ 0 & 1 & 0 \\ 0 & 0 & 1 \end{bmatrix}$$

$$= \begin{bmatrix} \cos(\theta_1+\theta_2+\theta_3) & -\sin(\theta_1+\theta_2+\theta_3) & L_1\cos\theta_1+L_2\cos(\theta_1+\theta_2)+L_3\cos(\theta_1+\theta_2+\theta_3) \\ \sin(\theta_1+\theta_2+\theta_3) & \cos(\theta_1+\theta_2+\theta_3) & L_1\sin\theta_1+L_2\sin(\theta_1+\theta_2)+L_3\sin(\theta_1+\theta_2+\theta_3) \\ 0 & 0 & 1 \end{bmatrix}$$

Resulting kinematic equations are:

$$x = L_1 \cos \theta_1 + L_2 \cos (\theta_1 + \theta_2) + L_3 \cos (\theta_1 + \theta_2 + \theta_3)$$

$$y = L_1 \sin \theta_1 + L_2 \sin (\theta_1 + \theta_2) + L_3 \sin (\theta_1 + \theta_2 + \theta_3)$$

Forward kinematics:

The position and orientation of the end-effector (in world space) can be determined from the joint angles and the link parameters by the following equations.

$$x_3 = L_1 \cos \theta_1 + L_2 \cos (\theta_1 + \theta_2) + L_3 \cos (\theta_1 + \theta_2 + \theta_3) \quad \dots (5)$$

$$y_3 = L_1 \sin \theta_1 + L_2 \sin (\theta_1 + \theta_2) + L_3 \sin (\theta_1 + \theta_2 + \theta_3) \quad \dots (6)$$

$$\phi = (\theta_1 + \theta_2 + \theta_3) \quad \dots (7)$$

Reverse Kinematics:

The joint angles can also be determined from the end-effector position (x_3, y_3) and the orientation (ϕ) , using reverse kinematics in the following way

$$x_2 = x_3 - L_3 \cos \phi \dots (8)$$

$$y_2 = y_3 - L_3 \sin \phi \dots (9)$$

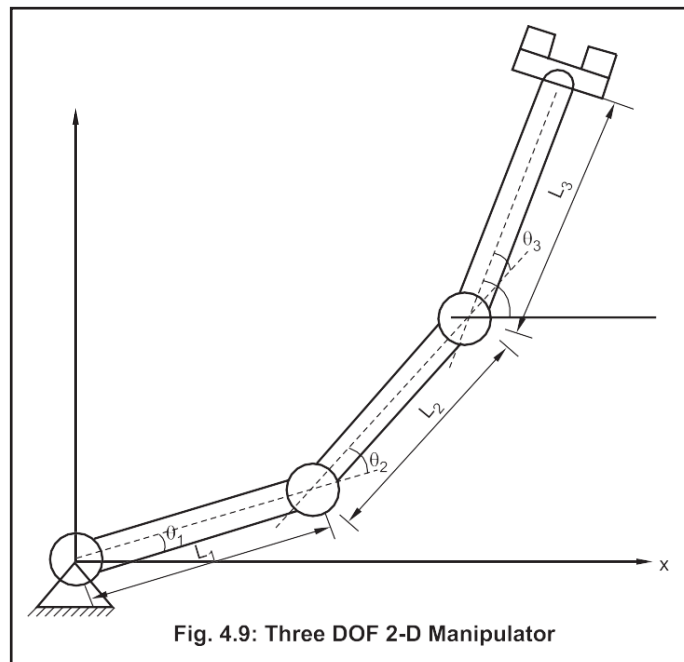

Fig. 4.9: Three DOF 2-D Manipulator

From the given geometry,

$$x_2 = L_1 \cos \theta_1 + L_2 \cos \theta_1 \cos \theta_2 - L_2 \sin \theta_1 \sin \theta_2 \dots (10)$$

$$y_2 = L_1 \sin \theta_1 + L_2 \sin \theta_1 \cos \theta_2 + L_2 \cos \theta_1 \sin \theta_2 \dots (11)$$

Squaring and adding Eqs. (10) and (11),

$$\cos \theta_2 = \frac{x_2^2 + y_2^2 - L_1^2 - L_2^2}{2 L_1 L_2} \dots (12)$$

Substituting the value of θ_2 in Eqs. (10) and (11), we obtain the value of θ_1 .

$$\text{(or) } \tan \theta_1 = \frac{y_2 (L_1 + L_2 \cos \theta_2) + x_2 (L_2 \sin \theta_2)}{x_2 (L_1 + L_2 \cos \theta_2) + y_2 (L_2 \sin \theta_2)} \dots (13)$$

Finally, the value of θ_3 can be obtained using the following relation.

$$\theta_3 = \phi - (\theta_1 + \theta_2) \dots (14)$$

HOMOGENEOUS TRANSFORMATIONS:

In the last articles, only three joints are analysed. When a more number of joints of manipulator is to be analysed, there should be a general single method to solve the kinematic equations, for this, homogeneous transformations are to be used. For knowing homogeneous transformations, the knowledge of vectors and matrices is necessary.

A point can be defined as

$$P = ai + bj + ck$$

It can be represented in matrix as

$$\begin{bmatrix} x \\ y \\ z \\ s \end{bmatrix} \quad \text{where} \quad a = \frac{x}{s} \quad s$$

$$b = \frac{y}{s}$$

$$c = \frac{z}{s} \quad \text{and}$$

$s = \text{scaling factor.}$

For example, $P = 20i + 15j + 30k$ can be given as

$$\begin{bmatrix} 20 \\ 15 \\ 30 \\ 1 \end{bmatrix} = \begin{bmatrix} 10 \\ 7.5 \\ 15 \\ 0.5 \end{bmatrix} = \begin{bmatrix} 40 \\ 30 \\ 60 \\ 2 \end{bmatrix}$$

The above vector form can be used to define end effector of robot manipulator. The vector can be translated in space by means of a translation matrix (4 X 4).

The vector can be rotated in space by means of rotation matrix (4 × 4).

Translation Matrix:

A vector can be translated in space by a distance

- a in x direction
- b in y direction
- c in z

direction and

it can be given as

$$\text{Trans (a, b, c)} = \begin{bmatrix} 1 & 0 & 0 & a \\ 0 & 1 & 0 & b \\ 0 & 0 & 1 & c \\ 0 & 0 & 0 & 1 \end{bmatrix}$$

Problem 2.1: Translate a vector $P = 30i + 20j + 15k$ by a distance of 10 in x direction, 8 in y direction and 2 in the z direction.

$$\text{Trans (a, b, c)} = \begin{bmatrix} 1 & 0 & 0 & 10 \\ 0 & 1 & 0 & 8 \\ 0 & 0 & 1 & 2 \\ 0 & 0 & 0 & 1 \end{bmatrix}$$

The translated vector

$$= \begin{bmatrix} 1 & 0 & 0 & 10 \\ 0 & 1 & 0 & 8 \\ 0 & 0 & 1 & 2 \\ 0 & 0 & 0 & 1 \end{bmatrix} \begin{bmatrix} 30 \\ 20 \\ 15 \\ 1 \end{bmatrix} = \begin{bmatrix} 40 \\ 28 \\ 17 \\ 1 \end{bmatrix}$$

[Explanation : $(1 \times 30) + (0 \times 20) + (0 \times 15) + (10 \times 1) = 40$

$(0 \times 30) + (1 \times 20) + (0 \times 15) + (8 \times 1) = 28$

$(0 \times 30) + (0 \times 20) + (1 \times 15) + (2 \times 1) = 17$

$(0 \times 30) + (0 \times 20) + (0 \times 15) + (1 \times 1) = 1.]$

Rotational Matrix:

A vector can be rotated about each of the three axes x, y and z by an angle θ by rotation matrix (4×4).

Rotations Matrix,

About x axis, $\text{Rot}(x, \theta) = \begin{bmatrix} 1 & 0 & 0 & 0 \\ 0 & \cos \theta & -\sin \theta & 0 \\ 0 & \sin \theta & \cos \theta & 0 \\ 0 & 0 & 0 & 1 \end{bmatrix}$

Rotation matrix, about y-axis

$$\text{Rot}(y, \theta) = \begin{bmatrix} \cos \theta & 0 & \sin \theta & 0 \\ 0 & 1 & 0 & 0 \\ -\sin \theta & 0 & \cos \theta & 0 \\ 0 & 0 & 0 & 1 \end{bmatrix}$$

Rotation matrix about z-axis,

$$\text{Rot}(z, \theta) = \begin{bmatrix} \cos \theta & -\sin \theta & 0 & 0 \\ \sin \theta & \cos \theta & 0 & 0 \\ 0 & 0 & 1 & 0 \\ 0 & 0 & 0 & 1 \end{bmatrix}$$

$\text{Rot}(x, \theta)$ can be written as $R(x, \theta)$

$$X = R \cdot A$$

$$A = R^{-1} \cdot X$$

Rotation	R Matrix	$R^{-1} = R^T$
$R(x, \theta)$	$\begin{bmatrix} 1 & 0 & 0 \\ 0 & \cos \theta & -\sin \theta \\ 0 & \sin \theta & \cos \theta \end{bmatrix}$	$\begin{bmatrix} 1 & 0 & 0 \\ 0 & \cos \theta & \sin \theta \\ 0 & -\sin \theta & \cos \theta \end{bmatrix}$
$R(y, \theta)$	$\begin{bmatrix} \cos \theta & 0 & \sin \theta \\ 0 & 1 & 0 \\ -\sin \theta & 0 & \cos \theta \end{bmatrix}$	$\begin{bmatrix} \cos \theta & 0 & -\sin \theta \\ 0 & 1 & 0 \\ \sin \theta & 0 & \cos \theta \end{bmatrix}$
$R(z, \theta)$	$\begin{bmatrix} \cos \theta & -\sin \theta & 0 \\ \sin \theta & \cos \theta & 0 \\ 0 & 0 & 1 \end{bmatrix}$	$\begin{bmatrix} \cos \theta & \sin \theta & 0 \\ -\sin \theta & \cos \theta & 0 \\ 0 & 0 & 1 \end{bmatrix}$

UNIT-III
KINEMATICS AND DYNAMICS

JACOBIANS:

The position and orientation of the manipulator end-effector can be evaluated in relation to joint displacements. The joint displacements corresponding to a given end-effector location can be obtained by solving the kinematic equation for the manipulator. This preliminary analysis permitted the robotic system to place the end-effector at a specified location in space. In addition to find the final location of the end-effector, the velocity at which the end-effector moves should also be found out. In order to move the end-effector in a specified direction at a specified speed, it is necessary to coordinate the motion of the individual joints and to achieve coordinated motion in multiple-joint robotic systems. The end-effector position and orientation are directly related to the joint displacements. Hence, in order to coordinate joint motions, the differential relationship between the joint displacements and the end-effector location should be derived to find out the individual joint motions.

Differential Relationship:

Ref. Fig. 3.1.

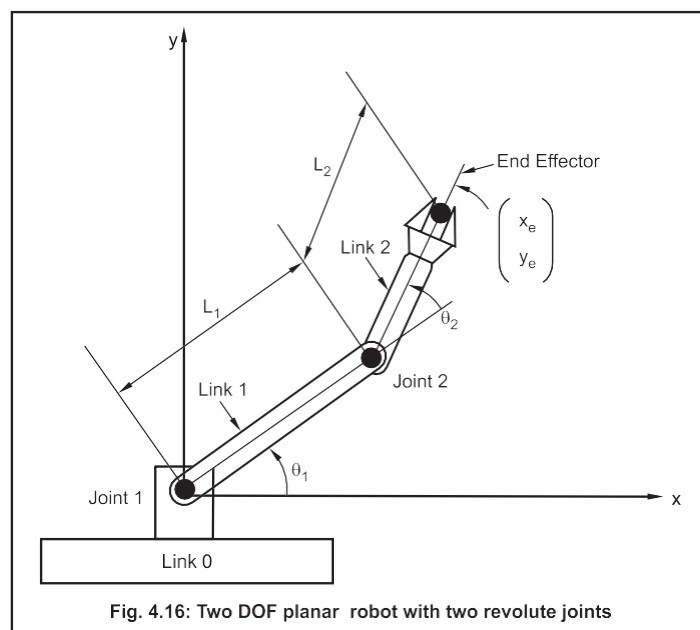

The kinematic equations relating the end-effector coordinates x_e and y_e to the joint displacements θ_1 and θ_2 are given by

$$x_e(\theta_1, \theta_2) = L_1 \cos \theta_1 + L_2 \cos(\theta_1 + \theta_2) \dots (1)$$

$$y_e(\theta_1, \theta_2) = L_1 \sin \theta_1 + L_2 \sin(\theta_1 + \theta_2) \dots (2)$$

Small movements of the individual joints at the current position, and the resultant motion of the end-effector, can be obtained by the total derivatives of the above kinematic equations:

$$dx_e = \frac{\partial x_e}{\partial \theta_1} d\theta_1 + \frac{\partial x_e}{\partial \theta_2} d\theta_2 \quad \dots (3)$$

$$dy_e = \frac{\partial y_e}{\partial \theta_1} d\theta_1 + \frac{\partial y_e}{\partial \theta_2} d\theta_2 \quad \dots (4)$$

where x_e , y_e are variables of both θ_1 and θ_2 , hence two partial derivatives are involved in the total derivatives. In vector form, the above equation can be reduced to

Where

$$d\mathbf{x}_e = \mathbf{J} \cdot d\mathbf{q} \quad \dots (5)$$

$$d\mathbf{x}_e = \begin{pmatrix} dx_e \\ dy_e \end{pmatrix}, \quad d\mathbf{q} = \begin{pmatrix} d\theta_1 \\ d\theta_2 \end{pmatrix} \quad \dots (6)$$

and \mathbf{J} is a 2 by 2 Jacobian matrix given by

$$\mathbf{J} = \begin{pmatrix} \frac{\partial x_e}{\partial \theta_1} & \frac{\partial x_e}{\partial \theta_2} \\ \frac{\partial y_e}{\partial \theta_1} & \frac{\partial y_e}{\partial \theta_2} \end{pmatrix} \quad \dots (7)$$

The matrix \mathbf{J} comprises the partial derivatives of the function x_e and y_e with respect to joint displacements θ_1 and θ_2 . The matrix \mathbf{J} , is called as **Jacobian Matrix**, Since most of the robot mechanisms have multiples of active joints, a Jacobian matrix is needed for describing the mapping of the vectorial joint motion to the vectorial end-effector motion.

For the two-dof robot arm of Figure 3.1, the components of the Jacobian matrix are computed as

$$\mathbf{J} = \begin{pmatrix} -L_1 \sin \theta_1 - L_2 \sin (\theta_1 + \theta_2) & -L_2 \sin (\theta_1 + \theta_2) \\ L_1 \cos \theta_1 + L_2 \cos (\theta_1 + \theta_2) & L_2 \cos (\theta_1 + \theta_2) \end{pmatrix} \quad \dots (8)$$

Hence the Jacobian collectively represents the sensitivities of individual end-effector coordinates to individual joint displacements. This sensitivity information is needed in order to coordinate the multi dof joint displacements for generating a desired motion at the end-effector.

When the two joints of the robot arm are moving at joint velocities

$$\dot{\mathbf{q}} = (\dot{\theta}_1, \dot{\theta}_2)^T, \text{ and let } \mathbf{v}_e = (\dot{x}_e, \dot{y}_e)^T$$

be the resultant end-effector velocity vector. The Jacobian provides the relationship between the joint velocities and the resultant end-effector velocity. Dividing equ. (5) by the infinitesimal time increment dt yields.

$$\frac{d \mathbf{x}_e}{dt} = \mathbf{J} \frac{d \mathbf{q}}{dt}, \text{ or } \boxed{\mathbf{v}_e = \mathbf{J} \cdot \dot{\mathbf{q}}} \quad \dots (9)$$

Thus the Jacobian determines the velocity relationship between the joints and the end-effector.

DIRECT KINEMATICS

• Manipulator

series of links connected by means of joints

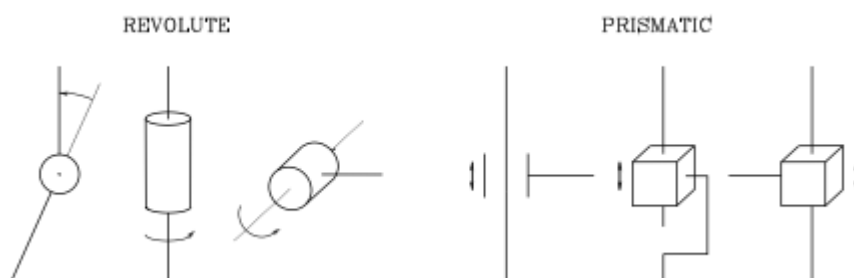

Kinematic chain (from base to end-effector)

open (only one sequence)

closed (loop)

Degree of freedom

associated with a joint articulation = joint variable

Base frame and end-effector frame

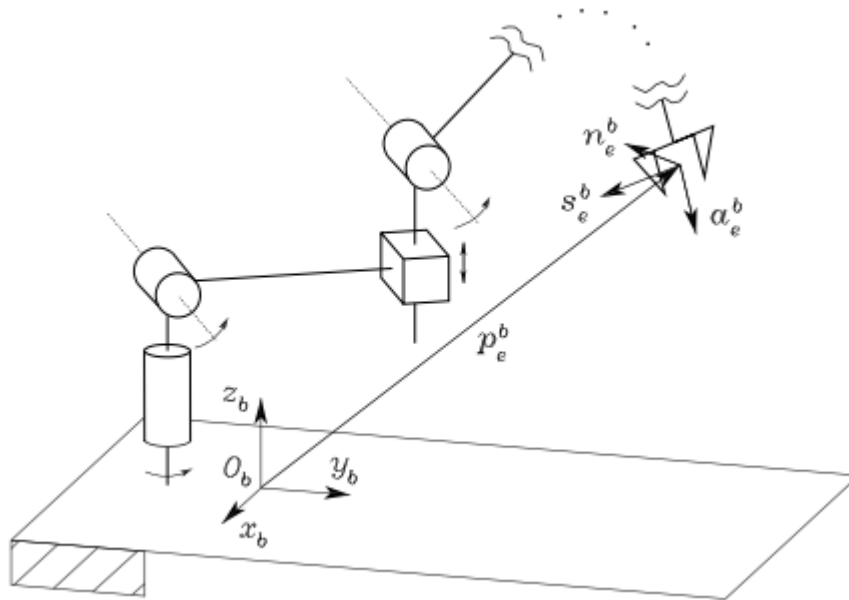

Direct kinematics equation

$$T_e^b(q) = \begin{bmatrix} n_e^b(q) & s_e^b(q) & a_e^b(q) & p_e^b(q) \\ 0 & 0 & 0 & 1 \end{bmatrix}$$

Two-link planar arm

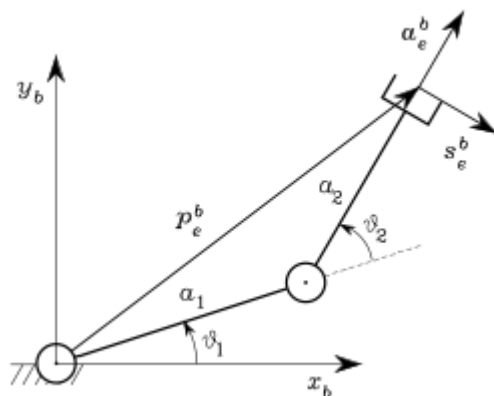

$$T_e^b(q) = \begin{bmatrix} n_e^b & s_e^b & a_e^b & p_e^b \\ 0 & 0 & 0 & 1 \end{bmatrix}$$

$$= \begin{bmatrix} 0 & s_{12} & c_{12} & a_1 c_1 + a_2 c_{12} \\ 0 & -c_{12} & s_{12} & a_1 s_1 + a_2 s_{12} \\ 1 & 0 & 0 & 0 \\ 0 & 0 & 0 & 1 \end{bmatrix}$$

Denavit-Hartenberg convention

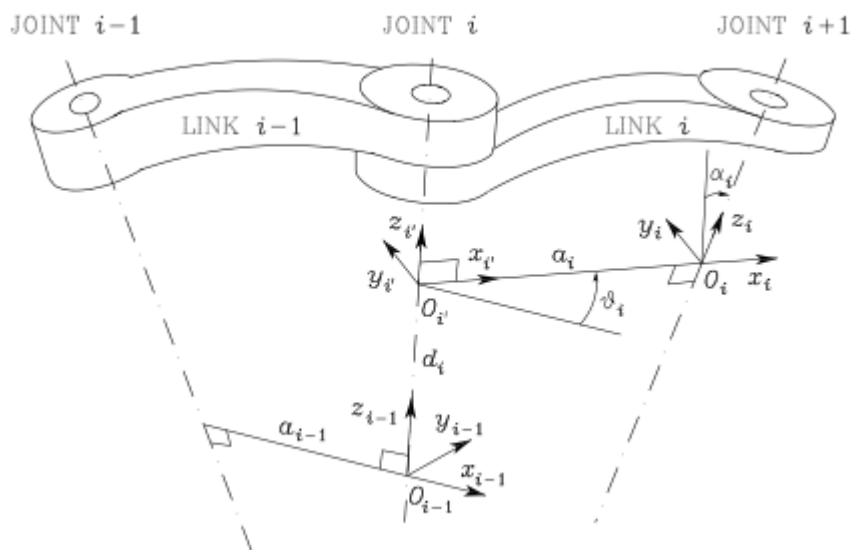

- choose axis z_i along axis of Joint $i + 1$
- locate O_i at the intersection of axis z_i with the common normal to axes z_{i-1} and z_i , and O'_{i-1} at intersection of common normal with axis z_{i-1}
- choose axis x_i along common the normal to axes z_{i-1} and z_i with positive direction from Joint i to Joint $i + 1$
- choose axis y_i so as to complete right-handed frame
- Nonunique definition of link frame:

For Frame 0, only the direction of axis z_0 is specified: then O_0 and X_0 can be chosen arbitrarily.

For Frame n , since there is no Joint $n + 1$, z_n is not uniquely defined while x_n has to be normal to axis z_{n-1} ; typically Joint n is revolute and thus z_n can be aligned with z_{n-1} .

when two consecutive axes are parallel, the common normal between them is not uniquely defined.

when two consecutive axes intersect, the positive direction of x_i is arbitrary.

When Joint i is prismatic, only the direction of z_{i-1} is specified.

Denavit–Hartenberg parameters

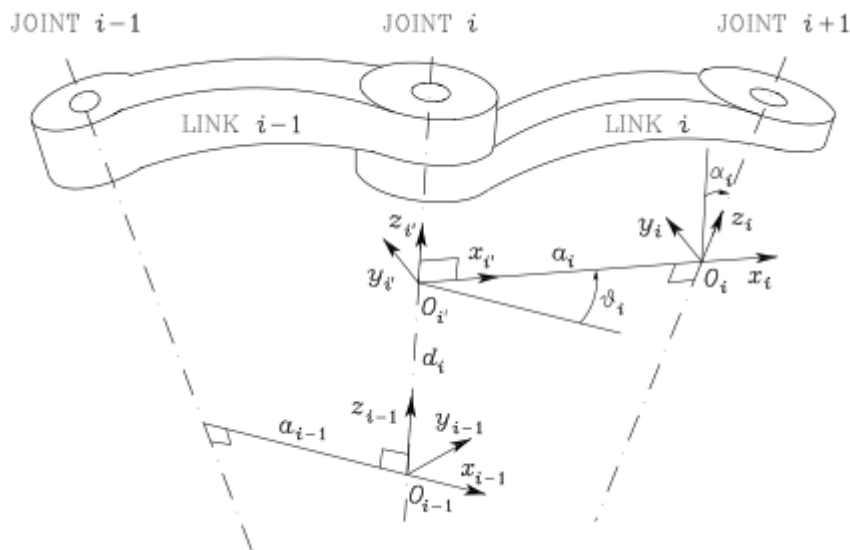

a_i distance between O_i and O_{i+1} ;

d_i coordinate of O_i and z_{i-1} ;

α_i angle between axes z_{i-1} and z_i about axis x_i to be taken positive when rotation is made counter-clockwise

α_i angle between axes x_{i-1} and x_i about axis z_{i-1} to be taken positive when rotation is made counter-clockwise

a_i and α_i are always constant

if Joint i is revolute the variable is θ_i

if Joint i is prismatic the variable is d_i

• Coordinate transformation

$$A_{i-1}^{i'} = \begin{bmatrix} c_{\theta_i} & -s_{\theta_i} & 0 & 0 \\ s_{\theta_i} & c_{\theta_i} & 0 & 0 \\ 0 & 0 & 1 & d_i \\ 0 & 0 & 0 & 1 \end{bmatrix}$$

$$A_i^{i'} = \begin{bmatrix} 1 & 0 & 0 & a_i \\ 0 & c_{\alpha_i} & -s_{\alpha_i} & 0 \\ 0 & s_{\alpha_i} & c_{\alpha_i} & 0 \\ 0 & 0 & 0 & 1 \end{bmatrix}$$

$$A_i^{i-1}(q_i) = A_{i'}^{i-1} A_i^{i'} = \begin{bmatrix} c_{\theta_i} & -s_{\theta_i} c_{\alpha_i} & s_{\theta_i} s_{\alpha_i} & a_i c_{\theta_i} \\ s_{\theta_i} & c_{\theta_i} c_{\alpha_i} & -c_{\theta_i} s_{\alpha_i} & a_i s_{\theta_i} \\ 0 & s_{\alpha_i} & c_{\alpha_i} & d_i \\ 0 & 0 & 0 & 1 \end{bmatrix}$$

Procedure

1. Find and number consecutively the joint axes; set the directions of axes z_0, \dots, z_{n-1} .
2. Choose Frame 0 by locating the origin on axis z_0 ; axes x_0 and y_0 are chosen so as to obtain a righthanded frame. If feasible, it is worth choosing Frame 0 to coincide with the base frame.

Execute steps from 3 to 5 for $i = 1, \dots, n - 1$:

3. Locate the origin O_i at the intersection of z_i with the common normal to axes z_{i-1} and z_i . If axes z_{i-1} and z_i are parallel and Joint i is revolute, then locate O_i so that $d_i=0$; if Joint i is prismatic, locate O_i at a reference position for the joint range, e.g., a mechanical limit.
4. Choose axis x_i along the common normal to axes z_{i-1} and z_i with direction from Joint i to Joint $i + 1$.
5. Choose axis y_i so as to obtain a right-handed frame to complete.
6. Choose Frame n ; if Joint n is revolute, then align z_n with z_{n-1} , otherwise, if Joint n is prismatic, then choose z_n arbitrarily. Axis x_n is set according to step 4.
7. For $i = 1, \dots, n$, form the table of parameters $a_i, d_i, \alpha_i, \theta_i$.
8. On the basis of the parameters in 7, compute the homogeneous transformation matrices $A_i^{i-1}(q_i)$ for $i=1, \dots, n$.
9. Compute the homogeneous transformation $T_n^0(q)=A_1^0 \dots A_n^{n-1}$ they yields the position and orientation of Frame n with respect to Frame 0.
10. Given T_0^b and T_e^n , compute the direct kinematics function as $T_e^b(q)=T_0^b T_n^0 T_e^n$ that yields the position and orientation of the end-effector frame with respect to the base frame.

Three-link planar arm

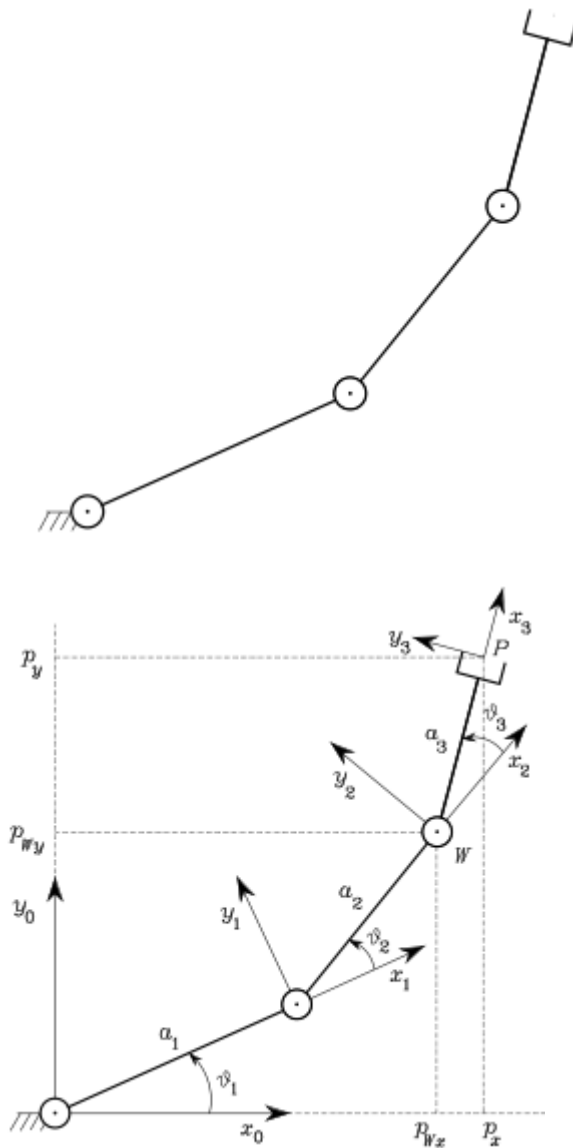

Link	a_i	α_i	d_i	ϑ_i
1	a_1	0	0	ϑ_1
2	a_2	0	0	ϑ_2
3	a_3	0	0	ϑ_3

$$A_i^{i-1} = \begin{bmatrix} c_i & -s_i & 0 & a_i c_i \\ s_i & c_i & 0 & a_i s_i \\ 0 & 0 & 1 & 0 \\ 0 & 0 & 0 & 1 \end{bmatrix} \quad i = 1, 2, 3$$

$$T_3^0 = A_1^0 A_2^1 A_3^2$$

$$= \begin{bmatrix} c_{123} & -s_{123} & 0 & a_1 c_1 + a_2 c_{12} + a_3 c_{123} \\ s_{123} & c_{123} & 0 & a_1 s_1 + a_2 s_{12} + a_3 s_{123} \\ 0 & 0 & 1 & 0 \\ 0 & 0 & 0 & 1 \end{bmatrix}$$

Spherical arm

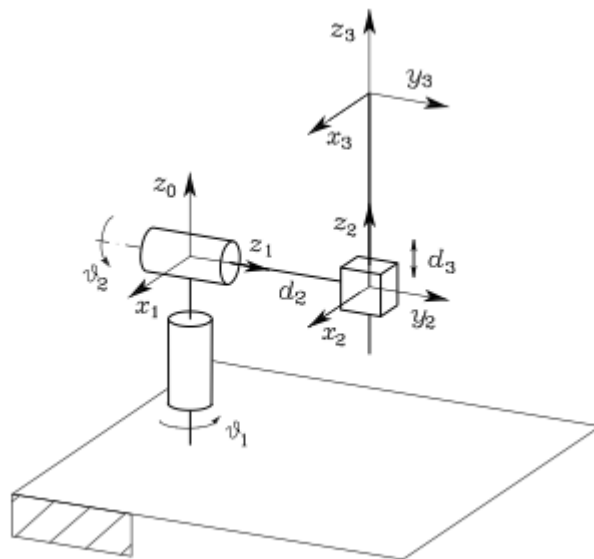
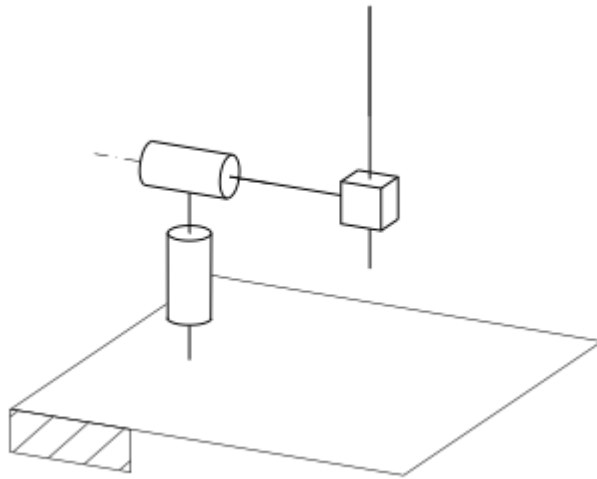

Link	a_i	α_i	d_i	ϑ_i
1	0	$-\pi/2$	0	ϑ_1
2	0	$\pi/2$	d_2	ϑ_2
3	0	0	d_3	0

$$A_1^0 = \begin{bmatrix} c_1 & 0 & -s_1 & 0 \\ s_1 & 0 & c_1 & 0 \\ 0 & -1 & 0 & 0 \\ 0 & 0 & 0 & 1 \end{bmatrix} \quad A_2^1 = \begin{bmatrix} c_2 & 0 & s_2 & 0 \\ s_2 & 0 & -c_2 & 0 \\ 0 & 1 & 0 & d_2 \\ 0 & 0 & 0 & 1 \end{bmatrix} \quad A_3^2 = \begin{bmatrix} 1 & 0 & 0 & 0 \\ 0 & 1 & 0 & 0 \\ 0 & 0 & 1 & d_3 \\ 0 & 0 & 0 & 1 \end{bmatrix}$$

$$T_3^0 = A_1^0 A_2^1 A_3^2$$

$$= \begin{bmatrix} c_1 c_2 & -s_1 & c_1 s_2 & c_1 s_2 d_3 - s_1 d_2 \\ s_1 c_2 & c_1 & s_1 s_2 & s_1 s_2 d_3 + c_1 d_2 \\ -s_2 & 0 & c_2 & c_2 d_3 \\ 0 & 0 & 0 & 1 \end{bmatrix}$$

Anthropomorphic arm

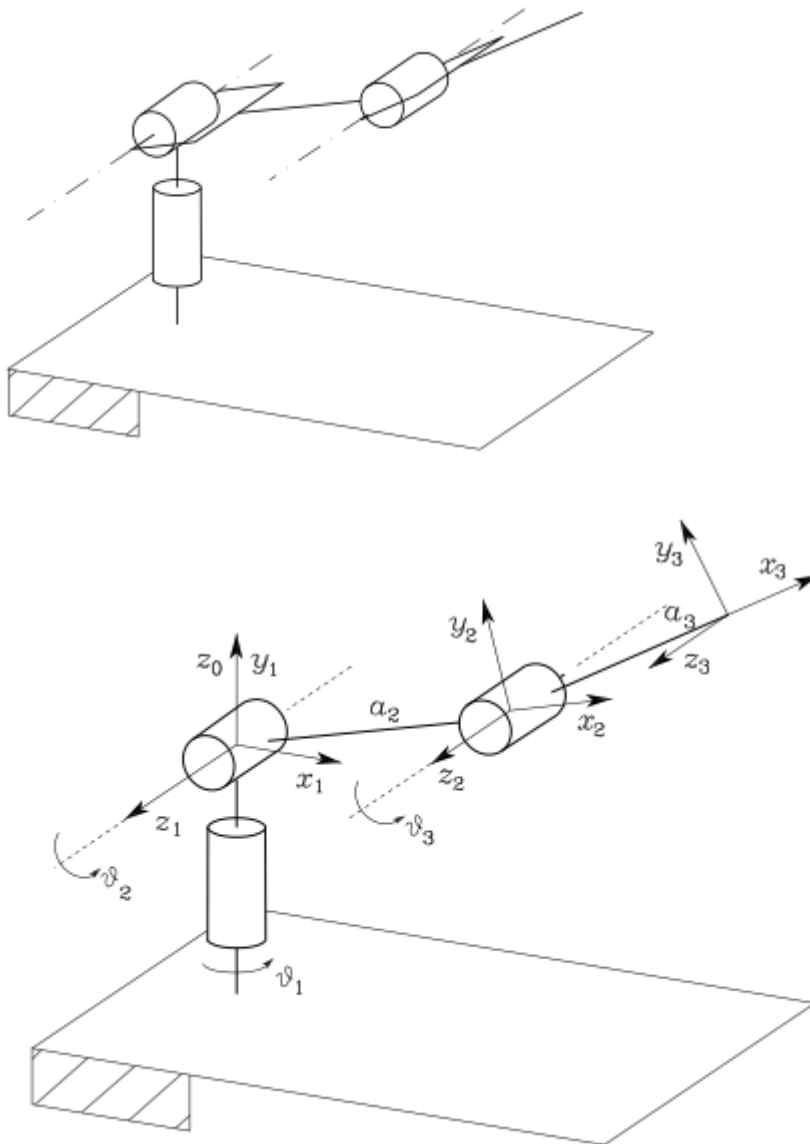

Link	a_i	α_i	d_i	ϑ_i
1	0	$\pi/2$	0	ϑ_1
2	a_2	0	0	ϑ_2
3	a_3	0	0	ϑ_3

$$A_1^0 = \begin{bmatrix} c_1 & 0 & s_1 & 0 \\ s_1 & 0 & -c_1 & 0 \\ 0 & 1 & 0 & 0 \\ 0 & 0 & 0 & 1 \end{bmatrix} A_i^{i-1} = \begin{bmatrix} c_i & -s_i & 0 & a_i c_i \\ s_i & c_i & 0 & a_i s_i \\ 0 & 0 & 1 & 0 \\ 0 & 0 & 0 & 1 \end{bmatrix} \quad i = 2, 3$$

$$T_3^0 = A_1^0 A_2^1 A_3^2$$

$$= \begin{bmatrix} c_1 c_{23} & -c_1 s_{23} & s_1 & c_1(a_2 c_2 + a_3 c_{23}) \\ s_1 c_{23} & -s_1 s_{23} & -c_1 & s_1(a_2 c_2 + a_3 c_{23}) \\ s_{23} & c_{23} & 0 & a_2 s_2 + a_3 s_{23} \\ 0 & 0 & 0 & 1 \end{bmatrix}$$

Spherical wrist

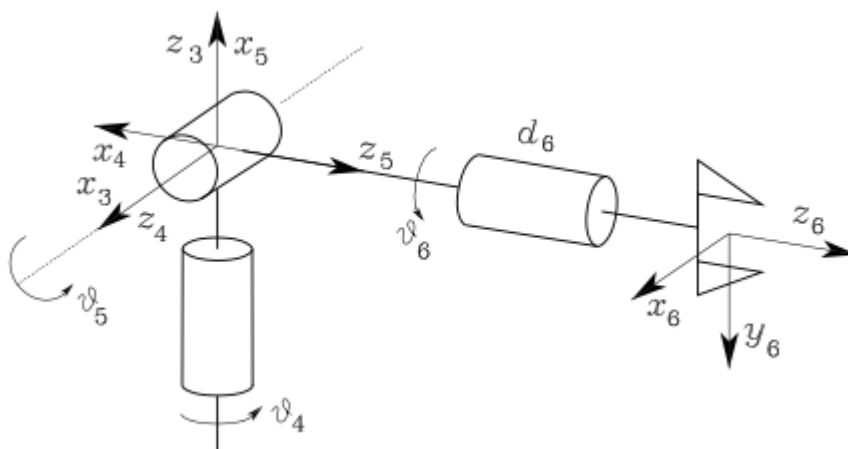
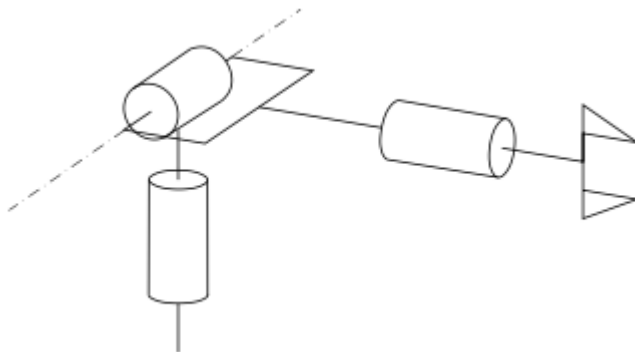

Link	a_i	α_i	d_i	ϑ_i
4	0	$-\pi/2$	0	ϑ_4
5	0	$\pi/2$	0	ϑ_5
6	0	0	d_6	ϑ_6

$$A_4^3 = \begin{bmatrix} c_4 & 0 & -s_4 & 0 \\ s_4 & 0 & c_4 & 0 \\ 0 & -1 & 0 & 0 \\ 0 & 0 & 0 & 1 \end{bmatrix} \quad A_5^4 = \begin{bmatrix} c_5 & 0 & s_5 & 0 \\ s_5 & 0 & -c_5 & 0 \\ 0 & 1 & 0 & 0 \\ 0 & 0 & 0 & 1 \end{bmatrix}$$

$$A_6^5 = \begin{bmatrix} c_6 & -s_6 & 0 & 0 \\ s_6 & c_6 & 0 & 0 \\ 0 & 0 & 1 & d_6 \\ 0 & 0 & 0 & 1 \end{bmatrix}$$

$$T_6^3 = A_4^3 A_5^4 A_6^5$$

$$= \begin{bmatrix} c_4 c_5 c_6 - s_4 s_6 & -c_4 c_5 s_6 - s_4 c_6 & c_4 s_5 & c_4 s_5 d_6 \\ s_4 c_5 c_6 + c_4 s_6 & -s_4 c_5 s_6 + c_4 c_6 & s_4 s_5 & s_4 s_5 d_6 \\ -s_5 c_6 & s_5 s_6 & c_5 & c_5 d_6 \\ 0 & 0 & 0 & 1 \end{bmatrix}$$

JOINT SPACE AND OPERATIONAL SPACE

Joint space

$$q = \begin{bmatrix} q_1 \\ \vdots \\ q_n \end{bmatrix}$$

$q_i = \vartheta_i$ (revolute joint)

$q_i = d_i$ (prismatic joint)

Operational space

$$x = \begin{bmatrix} P \\ \phi \end{bmatrix}$$

P (position)

Φ (orientation)

Direct kinematics equation

$$x = k(q)$$

Example

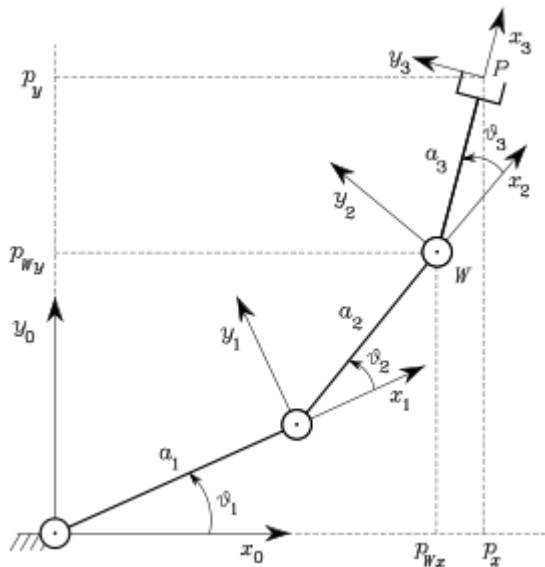

$$x = \begin{bmatrix} p_x \\ p_y \\ \phi \end{bmatrix} = k(q) = \begin{bmatrix} a_1 c_1 + a_2 c_{12} + a_3 c_{123} \\ a_1 s_1 + a_2 s_{12} + a_3 s_{123} \\ \vartheta_1 + \vartheta_2 + \vartheta_3 \end{bmatrix}$$

Workspace

- Reachable workspace

$$p = p(q) \quad q_{im} \leq q_i \leq q_{iM} \quad i = 1, \dots, n$$

surface elements of planar, spherical, toroidal and cylindrical type.

Dexterous workspace different orientations

Example

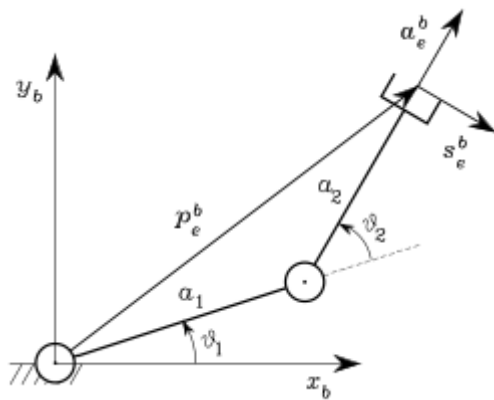

admissible configurations

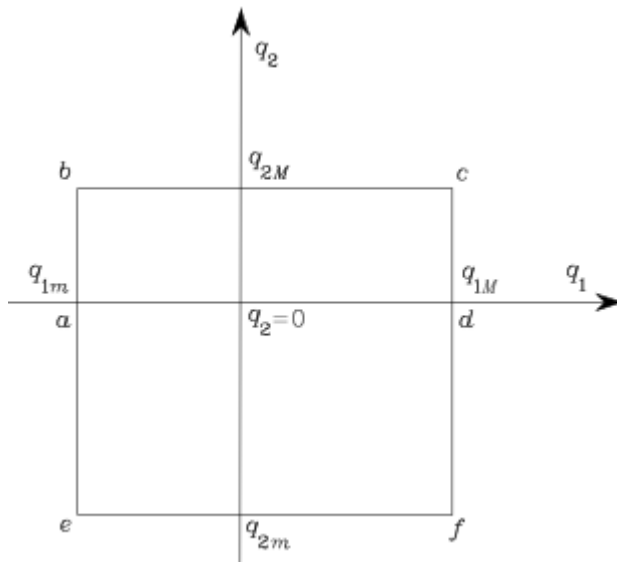

Workspace

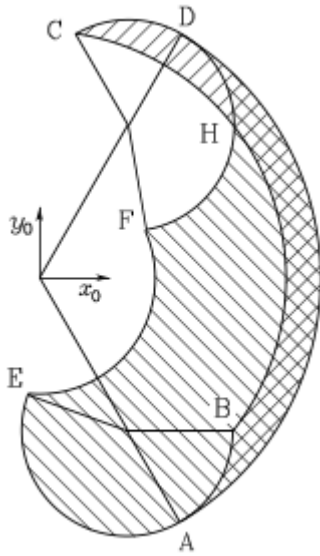

KINEMATIC CALIBRATION

- Accurate estimates of DH parameters to improve manipulator accuracy.
- Direct kinematics equation as a function of all parameters.

$$x = k(a, \alpha, d, \vartheta)$$

x_m measured pose

x_n nominal pose (fixed parameters + joint variables)

$$\begin{aligned} \Delta x &= \frac{\partial k}{\partial a} \Delta a + \frac{\partial k}{\partial \alpha} \Delta \alpha + \frac{\partial k}{\partial d} \Delta d + \frac{\partial k}{\partial \vartheta} \Delta \vartheta \\ &= \Phi(\zeta_n) \Delta \zeta \end{aligned}$$

l measurements ($l_m \gg 4n$)

$$\Delta \bar{x} = \begin{bmatrix} \Delta x_1 \\ \vdots \\ \Delta x_l \end{bmatrix} = \begin{bmatrix} \Phi_1 \\ \vdots \\ \Phi_l \end{bmatrix} \Delta \zeta = \bar{\Phi} \Delta \zeta$$

Solution

$$\Delta \zeta = (\bar{\Phi}^T \bar{\Phi})^{-1} \bar{\Phi}^T \Delta \bar{x}$$

INVERSE KINEMATICS PROBLEM

- Direct kinematics

$q \Rightarrow T$

$q \Rightarrow x$

- Inverse kinematics

$T \Rightarrow q$

$x \Rightarrow q$

- Complexity

closed-form solution

multiple solutions

infinite solutions

no admissible solutions

- Intuition

Algebraic

Geometric

- Numerical techniques

Solution of three-link planar arm

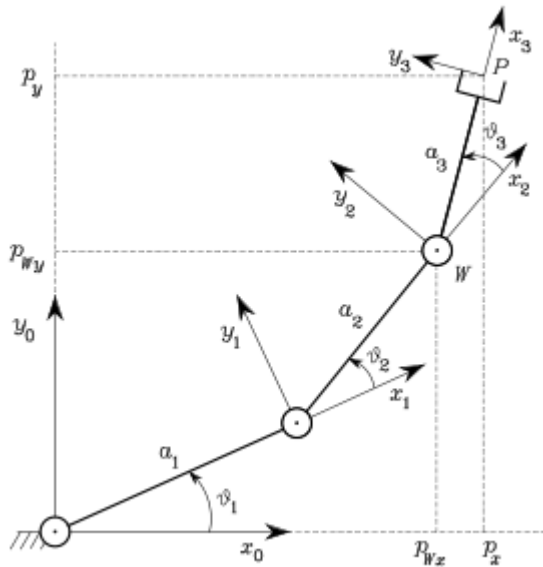

Algebraic solution

$$\phi = \vartheta_1 + \vartheta_2 + \vartheta_3$$

$$p_{Wx} = p_x - a_3 c_\phi = a_1 c_1 + a_2 c_{12}$$

$$p_{Wy} = p_y - a_3 s_\phi = a_1 s_1 + a_2 s_{12}$$

$$c_2 = \frac{p_{Wx}^2 + p_{Wy}^2 - a_1^2 - a_2^2}{2a_1 a_2}$$

$$s_2 = \pm \sqrt{1 - c_2^2}$$

$$\vartheta_2 = \text{Atan2}(s_2, c_2)$$

$$s_1 = \frac{(a_1 + a_2 c_2) p_{Wy} - a_2 s_2 p_{Wx}}{p_{Wx}^2 + p_{Wy}^2}$$

$$c_1 = \frac{(a_1 + a_2 c_2) p_{Wx} + a_2 s_2 p_{Wy}}{p_{Wx}^2 + p_{Wy}^2}$$

$$\vartheta_1 = \text{Atan2}(s_1, c_1)$$

$$\vartheta_3 = \phi - \vartheta_1 - \vartheta_2$$

Geometric solution

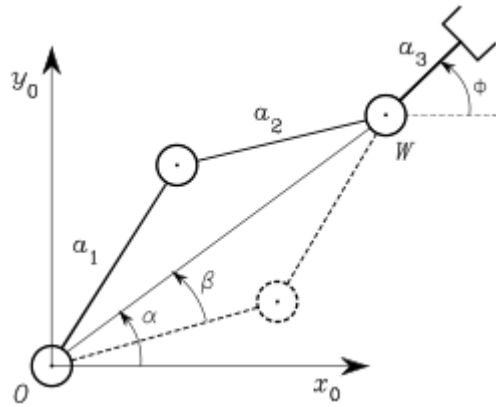

$$c_2 = \frac{p_{Wx}^2 + p_{Wy}^2 - a_1^2 - a_2^2}{2a_1a_2}$$

$$\vartheta_2 = \cos^{-1}(c_2)$$

$$\alpha = \text{Atan2}(p_{Wy}, p_{Wx})$$

$$c\beta \sqrt{p_{Wx}^2 + p_{Wy}^2} = a_1 + a_2 c_2$$

$$\beta = \cos^{-1} \left(\frac{p_{Wx}^2 + p_{Wy}^2 + a_1^2 - a_2^2}{2a_1 \sqrt{p_{Wx}^2 + p_{Wy}^2}} \right)$$

$$\vartheta_1 = \alpha \pm \beta$$

UNIT-IV
TRAJECTORY PLANNING AND ACTUATORS

Trajectory Generation

Introduction:

Trajectory (or) path describes the desired motion of a manipulator in space. Trajectory refers to a time history of position, velocity, and acceleration for each degree of freedom.

For generating the trajectory, position (θ), velocity ($\dot{\theta}$), and acceleration ($\ddot{\theta}$), are computed on digital computers, at a certain rate, called the **path-update rate**. In typical manipulator systems, this rate lie between 60 and 2000 Hz.

The motions of a manipulator can be considered as motions of the tool frame, $\{T\}$, relative to the station frame, $\{S\}$.

When we move the manipulator from an initial position to some desired final position that is, to move the tool frame from its current value,

$$\{T_{\text{initial}}\}, \text{ to a desired final value, } \{T_{\text{final}}\}.$$

in orientation and a change in the position of the tool relative to the station.

To specify the motion in detail, we should include a path description to give a sequence of desired via points (intermediate points between the initial and final positions). Thus for completing the motion, the tool frame must pass through a set of intermediate positions and orientations as described by the via points.

The path points includes all the via points plus the initial and final points.

For the motion of the manipulator to be smooth, we can define a smooth function as a function that is continuous and has a continuous first derivative, and a continuous second derivative.

Rough and jerky motions tend to cause increased wear on the mechanism and cause vibrations by exciting resonances in the manipulator. In order to guarantee smooth paths, there is a great variety of the ways that paths might be specified and planned. Any smooth functions of time, passing through the via points can be used to specify the exact path shape.

JOINT-SPACE SCHEMES:

In path generation, the path shapes (in space and in time) are described in terms of functions of joint angles.

Each path point is usually specified in terms of a desired position and orientation of the tool frame, $\{T\}$, relative to the station frame, $\{S\}$. Each of these via points is “converted” into a set of desired joint angles by using inverse kinematics. Then a smooth function is found for each of the n joints that pass through the via points and end at the goal point.

Cubic Polynomials:

Consider the problem of moving the tool from its initial position to a final position in a certain amount of time. Inverse kinematics allow the set of joint angles that correspond to the goal position and orientation to be calculated. t_0 is the initial position of the joint and t_f is the desired final position of that joint. There are many smooth functions, $\theta(t)$, to interpolate the joint value as shown in Fig. 4.1.

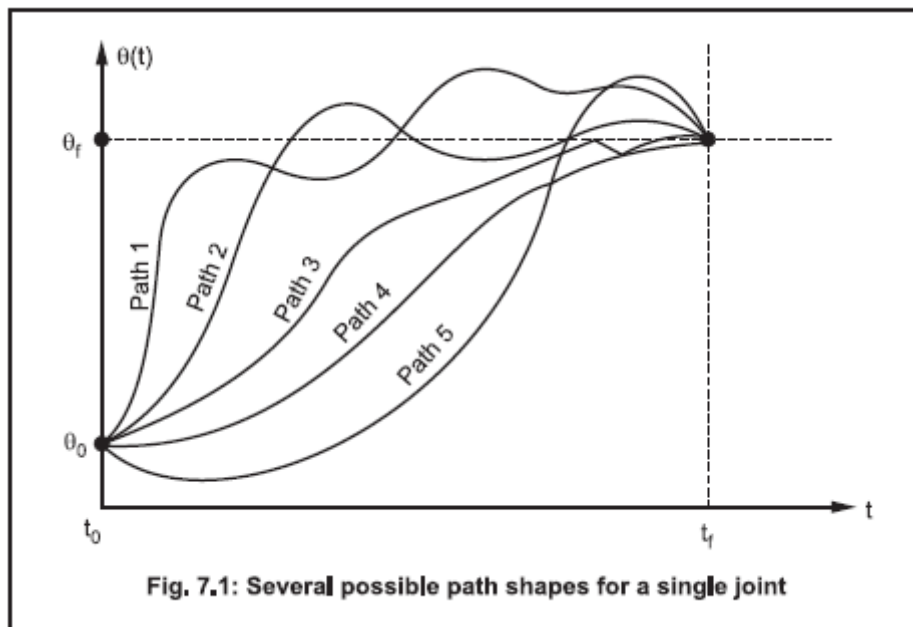

In making a single smooth motion, at least four constraints on $\theta(t)$ are needed. Two constraints are initial and final values.

Initial \rightarrow At $t = 0, \theta(0) = \theta_0,$

Final \rightarrow At $t = f, \theta(t_f) = \theta_f, \dots \dots \dots (1)$

An additional two constraints are that the function be continuous in velocity, which means that the initial and final velocity are zero.

Initially, Velocity, $\dot{\theta}(0) = 0,$

Finally, Velocity, $\dot{\theta}(t_f) = 0, \dots \dots \dots (2)$

These four constraints can be satisfied by a polynomial of at least third degree.

A cubic has the form

$$\theta(t) = a_0 + a_1 t + a_2 t^2 + a_3 t^3, \dots \dots \dots (3)$$

$$\begin{aligned} \text{The joint velocity } \dot{\theta}(t) &= a_1 + 2a_2 t + 3a_3 t^2 \\ \text{Acceleration } \ddot{\theta}(t) &= 2a_2 + 6a_3 t. \end{aligned} \quad \dots (4)$$

Applying four desired constraints yields four equations in four unknowns:

$$\theta_0 = a_0,$$

$$\theta_f = a_0 + a_1 t_f + a_2 t_f^2 + a_3 t_f^3,$$

$$\dot{\theta}(0) = 0 \quad \therefore a_1 = 0, \quad \dots (5)$$

$$\dot{\theta}(t_f) = 0 \Rightarrow 0 = a_1 + 2a_2 t_f + 3a_3 t_f^2,$$

Solving these equations for the a_i , we obtain

$$a_0 = \theta_0,$$

$$a_1 = 0,$$

$$a_2 = \frac{3}{t_f^2} (\theta_f - \theta_0) \quad \dots (6)$$

$$a_3 = -\frac{2}{t_f^3} (\theta_f - \theta_0)$$

Using equation (6), we can calculate the cubic polynomial that connects any initial joint angle position with any desired final position. This solution is for the case when the joint starts and finishes at zero velocity.

Cubic Polynomials for a path with via points:

In the last article, we have considered motions described by a desired duration and a final goal point. In general, we wish to decide paths to include intermediate via points. If the manipulator is to come to rest at each via point, then we can use the cubic solution explained in the last problem.

Usually, we wish to pass through a via point without stopping, and hence we should generalize the way to fit cubics to the path constraints.

For single goal point, each via point is usually specified in terms of a desired position and orientation of the tool frame relative to the station frame. Each of these via points is “converted” into a set of desired joint angles by using inverse kinematics. Then cubics can be computed to connect the via-point values for each joint together in a smooth way.

If desired velocities of the joints at the via points are known, then we can construct cubic polynomials. In the case, the velocity constraints at each end are not zero, but known velocity.

$$\text{Then equating (2) becomes } \left. \begin{array}{l} \dot{\theta}(0) = \dot{\theta}_0, \\ \dot{\theta}(t_f) = \dot{\theta}_f. \end{array} \right\} \dots (7)$$

Then four equations describing this general cubic are

$$\left. \begin{array}{l} \theta_0 = a_0, \\ \theta_f = a_0 + a_1 t_f + a_2 t_f^2 + a_3 t_f^3, \\ \dot{\theta}_0 = a_1, \\ \dot{\theta}_f = a_1 + 2a_2 t_f + 3a_3 t_f^2. \end{array} \right\} \dots (8)$$

Solving these equations for the a_i , we obtain

$$\left. \begin{array}{l} a_0 = \theta_0, \\ a_1 = \dot{\theta}_0, \\ a_2 = \frac{3}{t_f^2} (\theta_f - \theta_0) - \frac{2}{t_f} \dot{\theta}_0 - \frac{1}{t_f} \dot{\theta}_f, \\ a_3 = -\frac{2}{t_f^3} (\theta_f - \theta_0) + \frac{1}{t_f^2} (\dot{\theta}_f + \dot{\theta}_0). \end{array} \right\} \dots (9)$$

Using equation (9) the cubic polynomial can be calculated to connect any initial and final positions with any initial and final velocities.

PATH GENERATION AT RUN TIME:

At run time, the path-generator constructs the trajectory, usually in terms of θ , $\dot{\theta}$, and $\ddot{\theta}$, and feeds this information to the manipulator's control system.

This path generator computes the trajectory at the path-update rate.

UNIT -V
ELECTRIC ACTUATORS AND ROBOTIC APPLICATIONS

ROBOT APPLICATION IN MANUFACTURING

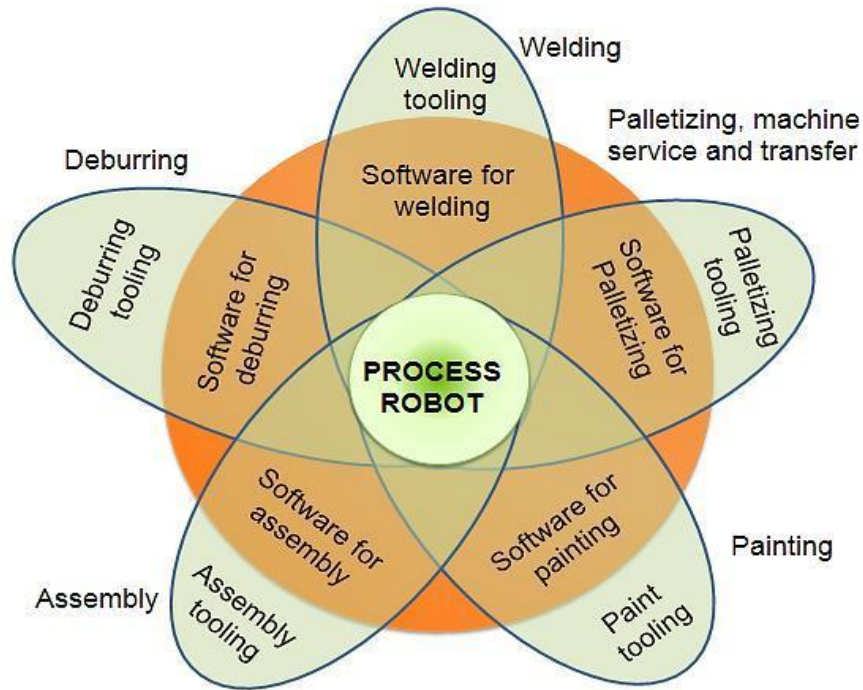

Fig. Applications of robots in industry and manufacturing

Figure shows a diagram which depicts an overview of applications of robots in manufacturing. The general characteristics of industrial work situations that tend to promote the substitution of robots for human labor.

Table Characteristics of situations where robots may substitute for humans

Situation	Description
Hazardous work environment for humans	In situations where the work environment is unsafe, unhealthy, uncomfortable, or otherwise unpleasant for humans, robot application may be considered.
Repetitive work cycle	If the sequence of elements in the work

	<p>cycle is the same, and the elements consist of relatively simple motions, robots usually perform the work with greater consistency and repeatability than humans.</p>
Difficult handling for humans	<p>If the task requires the use of heavy or difficult-to-handle parts or tools for humans, robots may be able to perform the operation more efficiently.</p>
Multi-shift operation	<p>A robot can replace two or three workers at a time in second or third shifts, thus they can provide a faster financial payback.</p>
Infrequent changeovers	<p>Robots' use is justified for long production runs where there are infrequent changeovers, as opposed to batch or job shop production where changeovers are more frequent.</p>
Part position and orientation are established in the work cell	<p>Robots generally don't have vision capabilities, which means parts must be precisely placed and oriented for</p>

Material Handling Applications

Robots are mainly used in three types of applications: material handling; processing operations; and assembly and inspection. In material handling, robots move parts between various locations by means of a gripper type end effector. Material handling activity can be subdivided into material transfer and machine loading and/or unloading.

Application	Description
Material transfer	<ul style="list-style-type: none"> • Main purpose is to pick up parts at one location and place them at a new location. Part re-orientation may be accomplished during the transfer. The most basic application is a pick-and-place procedure, by a low-technology robot (often

	<p>pneumatic), using only up to 4 joints.</p> <ul style="list-style-type: none"> • More complex is palletizing, where robots retrieve objects from one location, and deposit them on a pallet in a specific area of the pallet, thus the deposit location is slightly different for each object transferred. The robot must be able to compute the correct deposit location via powered lead-through method, or by dimensional analysis. • Other applications of material transfer include de-palletizing, stacking, and insertion operations.
Machine loading and/or unloading	<ul style="list-style-type: none"> • Primary aim is to transfer parts into or out-of a production machine. • There are three classes to consider: machine loading—where the robot loads the machine machine unloading—where the robot unloads the machine machine loading and unloading where the robot performs both actions • Used in die casting, plastic molding, metal machining operations, forging, press-working, and heat-treating operations.

Processing Operations

In processing operations, the robot performs some processing activities such as grinding, milling, etc. on the workpart. The end effector is equipped with the specialized tool required for the respective process. The tool is moved relative to the surface of the workpart. Table outlines the examples of various processing operations that deploy robots.

Table : Robotic process operations

Process	Description
Spot Welding	<p>Metal joining process in which two sheet metal parts are fused together at localized points of contact by the deployment of two electrodes that squeeze the metal together and apply an electric current. The electrodes constitute the spot welding gun, which is the end effector tool of the welding robot.</p>
Arc Welding	<p>Metal joining process that utilizes a continuous rather than contact welding point process, in the same way as above. Again, the end effector is the electrodes used to achieve the welding arc. The robot must use continuous path control, and a jointed arm robot consisting of six joints is frequently used.</p>
Spray Coating	<p>Spray coating directs a spray gun at the object to be coated. Paint or some other fluid flows through the nozzle of the spray gun, which is the end effector and is dispersed and applied over the surface of the object. Again, the robot must use continuous path control, and is typically programmed using manual lead-through. Jointed arm robots seem to be the most common anatomy for this application.</p>
Other applications	<p>Other applications include: drilling, routing, and other machining processes; grinding, wire brushing, and similar operations; waterjet cutting; and laser cutting.</p>

Work Cell Design and Control

Robot work cell layout

- Robot-centered work cell
- In-line robot work cell
- Mobile work cell

Robot-centered work cell

- Center of work cell
- High utilization of robot
- Method of work part delivery (eg: conveyor, part-feeders, pallets)
- Install for single robot servicing 1 @more production machines

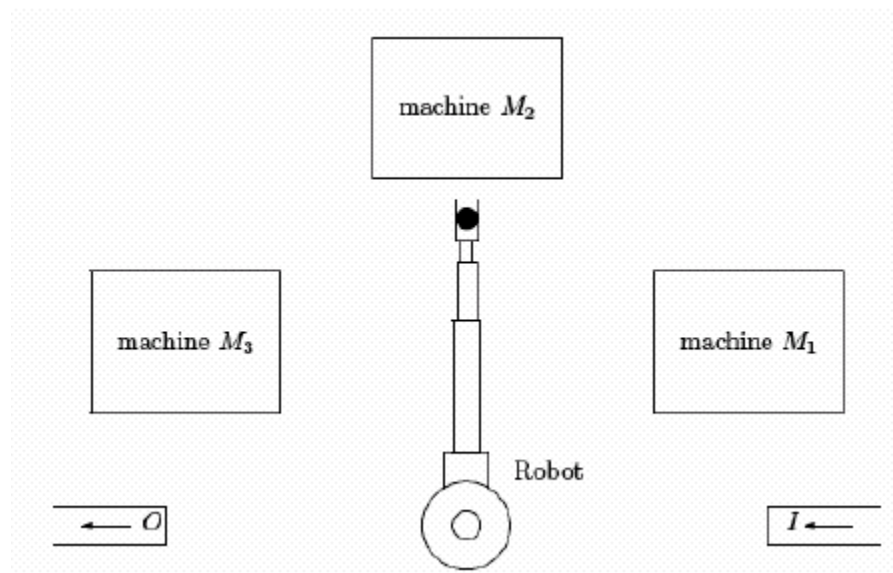
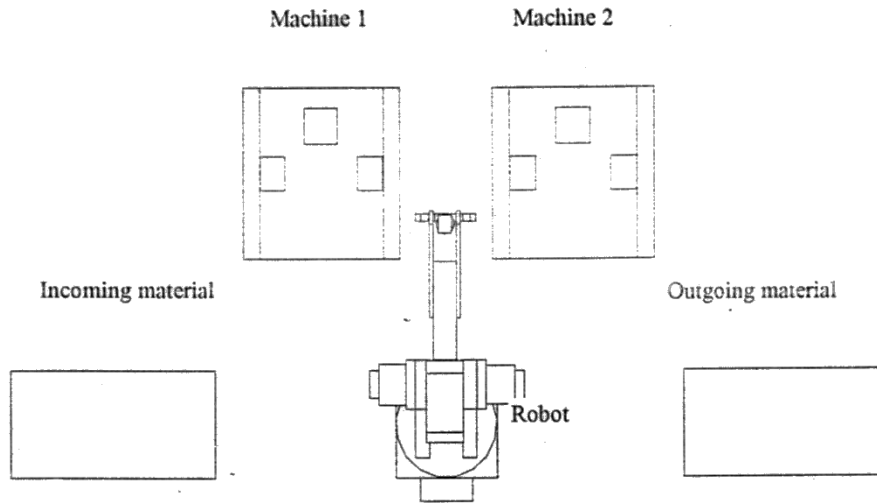

In-line robot work cell

- One or more robots located along in-line conveyor
- Work is organized so each robot performs assembly operation on each part (eg: welding line)

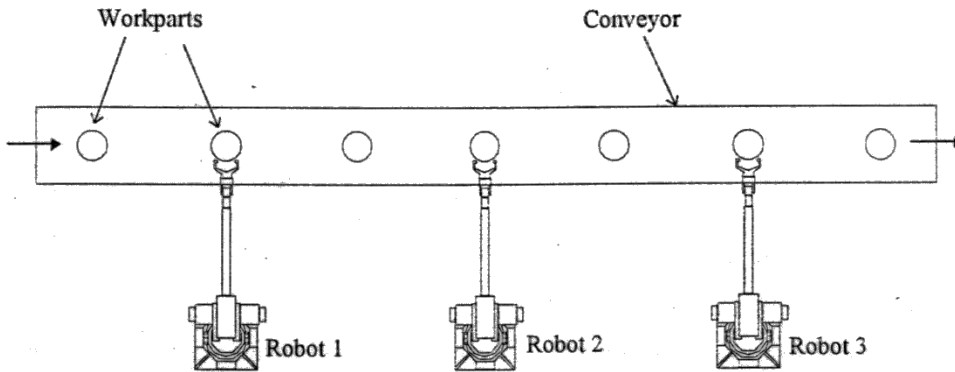

There are 3 types of work part transport system used in in-line robot work cell.

1. Intermittent Transfer
2. Continuous Transfer
3. Non-Synchronous Transfer

Intermittent Transfer

The parts are moved in a start-and-stop motion from one station to another along the line. It is also called synchronous transfer since all parts are moved simultaneously to the next stop.

The advantage of this system is that the parts are registered in a fixed location and orientation with respect to the robot during robot's work cycle.

Continuous Transfer

Work parts are moved continuously along the line at constant speed. The robot(s) has to perform the tasks as the parts are moving along.

The position and orientation of the parts with respect to any fixed location along the line are continuously changing.

This results in a "tracking" problem, that is, the robot must maintain the relative position and orientation of its tool with respect to the work part.

This tracking problem can be solved.

the moving baseline tracking system by moving the robot parallel to the conveyor at the same speed. or by the stationary baseline tracking system i.e. by computing and adjusting the robot tool to maintain the position and orientation with respect to the moving part.

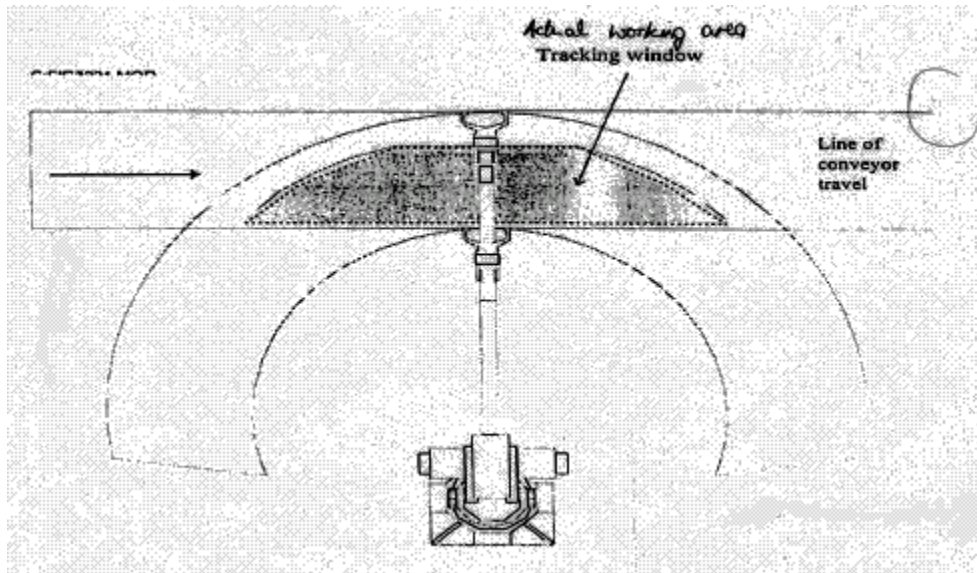

The second tracking system involves considerable engineering problems:

- firstly, the robot must have sufficient computational and control capabilities
- secondly the robot's tracking window must be adequate
- thirdly the sensor system to identify the different parts coming into the tracking window and also to track the moving part relative to the robot's tool

Non-synchronous Transfer System

This is a power and free system". Each work part moves independently of other parts. in a stop-and-go manner.

When a work station has finished working on a work part, that part then proceeds to the next work station. Hence, some parts are being processed on the line at the same time that others are being transported or located between stations. Here, the timing varies according to the cycle time requirements of each station.

The design and operation of this type of transfer system is more complicated than the other two because each part must be provided with its own independently operated moving cart.

However, the problem of designing and controlling the robot system used in the power-and-free method is less complicated than for the continuous transfer method.

Nonsynchronous Transfer System

For the irregular timing of arrivals, sensors must be provided to indicate to the robot when to begin its work cycle.

The more complex problem of part registration with respect to the robot that must be solved in the continuously moving conveyor systems are not encountered on either the intermittent transfer or the non-synchronous transfer.

Mobile work cell

In this arrangement, the robot is provided with a means of transport, such as a mobile base, within the work cell to perform various tasks at different locations.

The transport mechanism can be floor mounted tracks or overhead railing system that allows the robot to be moved along linear paths.

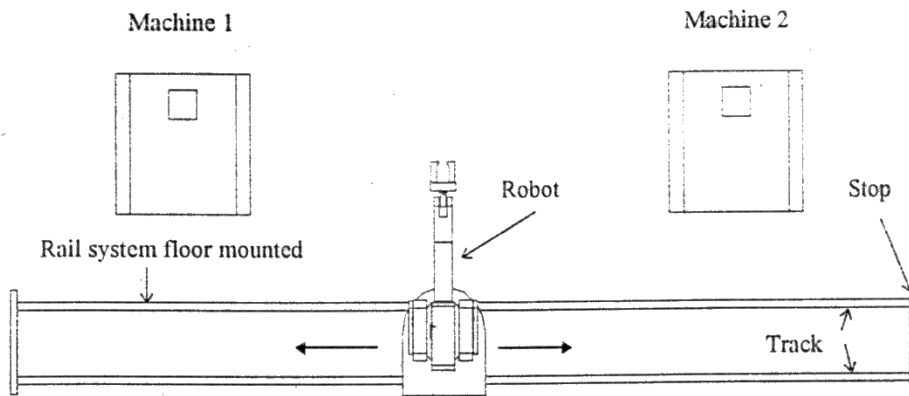

Mobile robot work cells are suitable for installations where the 1 robot must service more than one station (production machine) that has long processing cycles, and the stations cannot be arranged around the robot in a robot-centred cell arrangement.

One such reason could be due to the stations being geographically separated by distances greater than the robot's reach. The type of layout allows for time-sharing tasks that will lower the robot idle time. One of the problems in designing this work cell is to find the optimum number of stations or machines for the robot to service.

Transport mechanism: floor mounted at the overhead railing system

Service for more than one station

Problem: to find optimum number of station to service

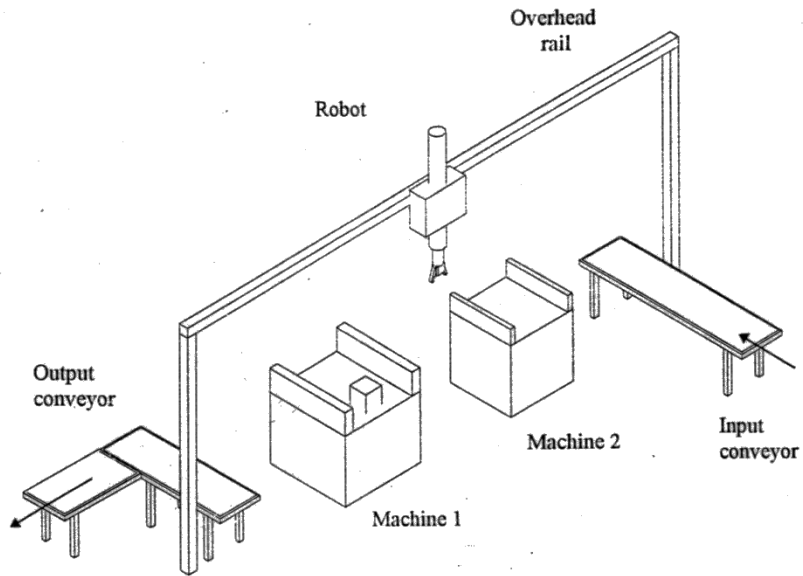

Some Modification in Work Cell Design

Modification to other equipment in the cell

Part position and orientation

Part identification problem

Protect of robot from its environment

Utilities

Control of work cell

Safety

i. Modifications to other equipment in the work cell

- Modifications need to be done in order to interface robots to equipment in the cell. Special fixtures and control devices must be devised for integrated operation.

- For example, the work holding nests. conveyor stops to position and orientate parts for robots.
- Changes has to be done in machines to allow by robots and use of limit switches and other devices to interface components

ii Part Position and Orientation

When parts are being delivered into the work cell, precise pick up locations along conveyors must be established.

Parts must be in a known position and orientation for the robot to grasp accurately. As the parts are being processed, the orientation must not be lost.

A way of achieving the above must be designed. For automated feeder systems, the design of the way parts are being presented to the work cell must be provided for.

iii. Part Identification problem

It there are more than one type of parts, there will be a necessity to identify various parts by automated means, such as optical techniques. magnetic techniques or limit switches that sense different sizes or geometry.

Electronic tagging may also be used with pallets so that the parts are identified by the information carried by the information card.

iv. Protection of robot from its environment

In applications such as spray painting. hot metal working conditions. abrasive applications. adhesive sealant applications, the robot has to be protected from possible adverse environment. (e.g. use of sleeves. long grippers).

v. Utilities

Requirements for electricity. air and hydraulic pressures. gas for furnaces has to be considered and provided for.

vi. Control of the work cell

The activities of the robot must be coordinated with those of the other equipment in the work cell.

vii. Safety

Human protection measures such as fences, barriers, safety interrupt system with sensors in and around the work cell must be provided.

This must be considered even at the early stages of the design of the work cell.

Work cell control

Sequence control

Operator interface

Safety monitoring

Sequence control

Sequence control includes:

Regulate the sequence of activities

Control of simultaneous activities

Making decision to proceed/stop/delay work based on events

In a work cell, the sequence of activities are as follows:

1. Robot picks up raw work part from conveyor at a known pick up location (machine idle)
2. Robot loads part into fixture at machining centre (machine idle).
3. Machining centre begins auto machining cycle (robot idle).
4. Machine completes auto machining. Robot unloads machine and places part on the machine on pallet (machine idle).
5. Robot moves back to pick up point (machine idle)

Here almost all activities occur sequentially. Therefore, the controller must ensure activities occur in correct sequence and that each step is completed before the next is started.

Notice that machine idle / robot idle is significant. If we fit a double gripper, productivity can be further improved.

The modified sequence of activities (with double gripper fitted):

1. Robot picks up raw work part using the first gripper from conveyor at a known pick up location. Robot moves its double gripper into ready position in front of machining centre (machine cycle in progress).
2. At completion of machine cycle, robot unloads finished part from the machine fixture with a second gripper and loads raw part into fixture with the first gripper (machine idle).
3. Machining centre begins auto machining cycle. Robot moves finished part to pallet and places it in programmed location on pallet.

4. Robot moves back to pick up point (machine cycle in progress).

- In the modified sequence, several activities occur simultaneously but initiated sequentially.

Sequence Control

Therefore, controller is to ensure the various control cycles begin at the required times. a

Controller must communicate back and forth with the various equipment (machining centre, conveyors and robot).

Signals must be sent by the controller, and other signals must be received from the components. These signals are called interlocks.

Operator Interface

Operator to interact with robot work cell.

Operator interface is required to:

Program the robot, modify and update programs

Let human operator participate in work cycle

Do data entry by human operator

Do emergency stopping activities

Safety Monitoring

Emergency stopping requires an alert operator to be present to notice the emergency and take action to interrupt the cycle (however, safety emergencies do not always occur at convenient times. when the operator is present).

Therefore, a more automatic and reliable means of protecting the cell equipment and people who might wander into the work zone. is imperative. This is safety monitoring.

Safety monitoring (or hazard monitoring) is a work cell control function where sensors are used to monitor status and activities of the cell. to detect the unsafe or potentially unsafe conditions.

There are various types sensors that can be used for such purpose. for example. limit switches to detect movements has occurred correctly. temperature sensors, pressure sensitive floor mats. light beams combined with photosensitive sensors. and machine vision.

The safety monitoring is programmed to respond to various hazard conditions in different ways:

Complete stoppage of cell activities.

Slowing down the robot speed to a safe level when human is present.

Warning buzzers to alert maintenance personnel of a safety hazard.

Specially programmed subroutines to permit the robot to recover from a particular unsafe event (this is called error detection and recovery).

Interlock

Interlocks provide means of preventing the work cycle sequence from continuing unless a certain or set of conditions are satisfied.

This is a very important feature of work cell control, that regulates the sequence of activities being carried out. Interlocks are essential for the coordination and synchronization of activities which could not be accomplished through timing alone.

Interlocks allow for variations in the times taken for certain elements in the work cycles. In the example case in section 4, interlocks would be used for the following purposes:

To ensure that a raw part was at the pick up location, before the robot tries to grasp it.

To determine when the machining cycle has been completed before robot attempts to load part onto fixture.

To indicate that the part has been successfully loaded so that the auto machining cycle can start.

Input interlocks.

Input interlocks make use of signals sent from the components in the cell to the controller.

They indicate that certain conditions have been met and that the programmed work sequence can continue. For example a limit switch on work fixture can send a signal to indicate that the part has been properly loaded.

Output interlocks.

Makes use of signals sent from the controller to other devices or machines in the work cell.

In our example an output signal is used to signal the machining centre to commence the auto cycle. The signal is contingent upon certain conditions being met, such as, that work part has

been properly loaded and the robot gripper has been moved to a safe distance. These conditions are usually determined by means of input interlocks.

In our example an output signal is used to signal the machining centre to commence the auto cycle. The signal is contingent upon certain conditions being met. such as. that work part has been properly loaded and the robot gripper has been moved to a safe distance. These conditions are usually determined by means of input interlocks.

In designing the work cell, we must not only consider the regular sequence of events during normal operation. but also the possible irregularities and malfunctions that might happen. In the regular cycle, the various sequential and simultaneous activities must be identified, together with the conditions that must be satisfied.

for the potential malfunctions, the applications engineer must determine a method of identifying that the malfunction has occurred and what action must be taken to respond to that malfunction. • Then for both the regular and the irregular events in the cycle. interlocks must be provided to accomplish the required sequence control and hazard monitoring that must occur during the work cycle.

In some cases. the interlock signals can be generated by the electronic controllers for the machines. For example NC machines would be capable of being interfaced to work cell controller to signal completion of auto machining cycle.

In other cases, the applications engineer must design the interlocks using sensors to generate the required signals.