

BASIC ELECTRICAL AND ELECTRONICS ENGINEERING

IARE- R16

Course code: AEE018

AERONAUTICAL ENGINEERING

Prepared By:

Ms. B. Manogna, Assistant Professor, EEE

Ms. B. Navothna, Assistant Professor, EEE



DEPARTMENT OF ELECTRICAL AND ELECTRONICS ENGINEERING

INSTITUTE OF AERONAUTICAL ENGINEERING

(Autonomous)

Dundigal – 500043, Hyderabad

UNIT –I

ELECTRIC CIRCUITS, ELECTROMAGNETISM AND INSTRUMENTS

The SI System

Base units:

- meter (m), kilogram (kg), second (s), ampere (A)
- also: kelvin, mole, and candela

Derived units:

- work or energy: joule (J)
- power (rate of doing work): watt (W)
- $1 \text{ W} = 1 \text{ J/s}$

SI: Units and Prefixes

Any measurement can be expressed in terms of a unit, or a unit with a “prefix” modifier.

FACTOR	NAME	SYMBOL
10^{-9}	nano	n
10^{-6}	micro	μ
10^{-3}	milli	m
10^3	kilo	k
10^6	mega	M

Example: $12.3 \text{ mW} = 0.0123 \text{ W} = 1.23 \times 10^{-2} \text{ W}$

Charge

- ▶ charge is *conserved*: it is neither created nor destroyed
- ▶ symbol: Q or q ; units are coulomb (C)
- ▶ the smallest charge, the *electronic charge*, is carried by an electron (-1.602×10^{-19} C) or a proton ($+1.602 \times 10^{-19}$ C)
- ▶ in most circuits, the charges in motion are electrons

Current and Charge

Current is the rate of charge flow:

1 ampere = 1 coulomb/second (or $1 \text{ A} = 1 \text{ C/s}$)

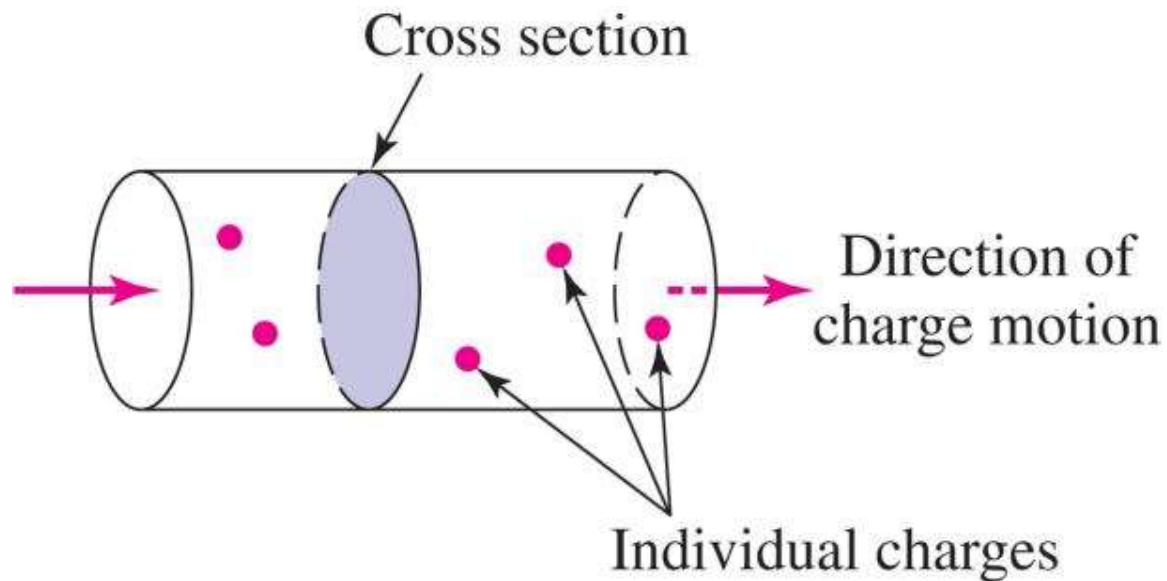

Current and Charge

- ▶ Current (designated by I or i) is the rate of flow of charge
- ▶ Current must be designated with both a direction and a magnitude
- ▶ These two currents are the same:

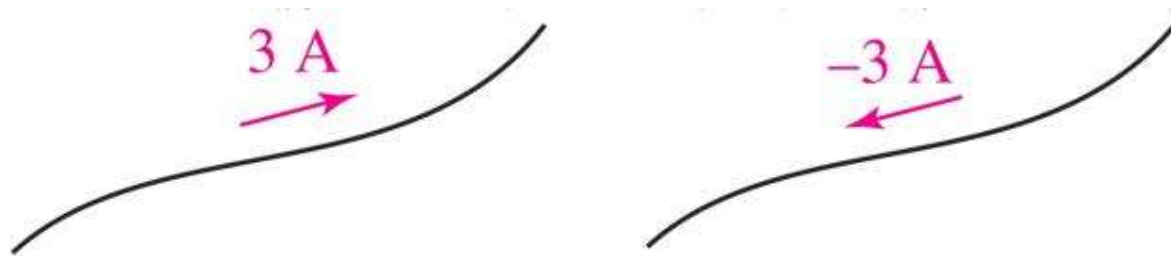

Current and Charge: $i = dq/dt$

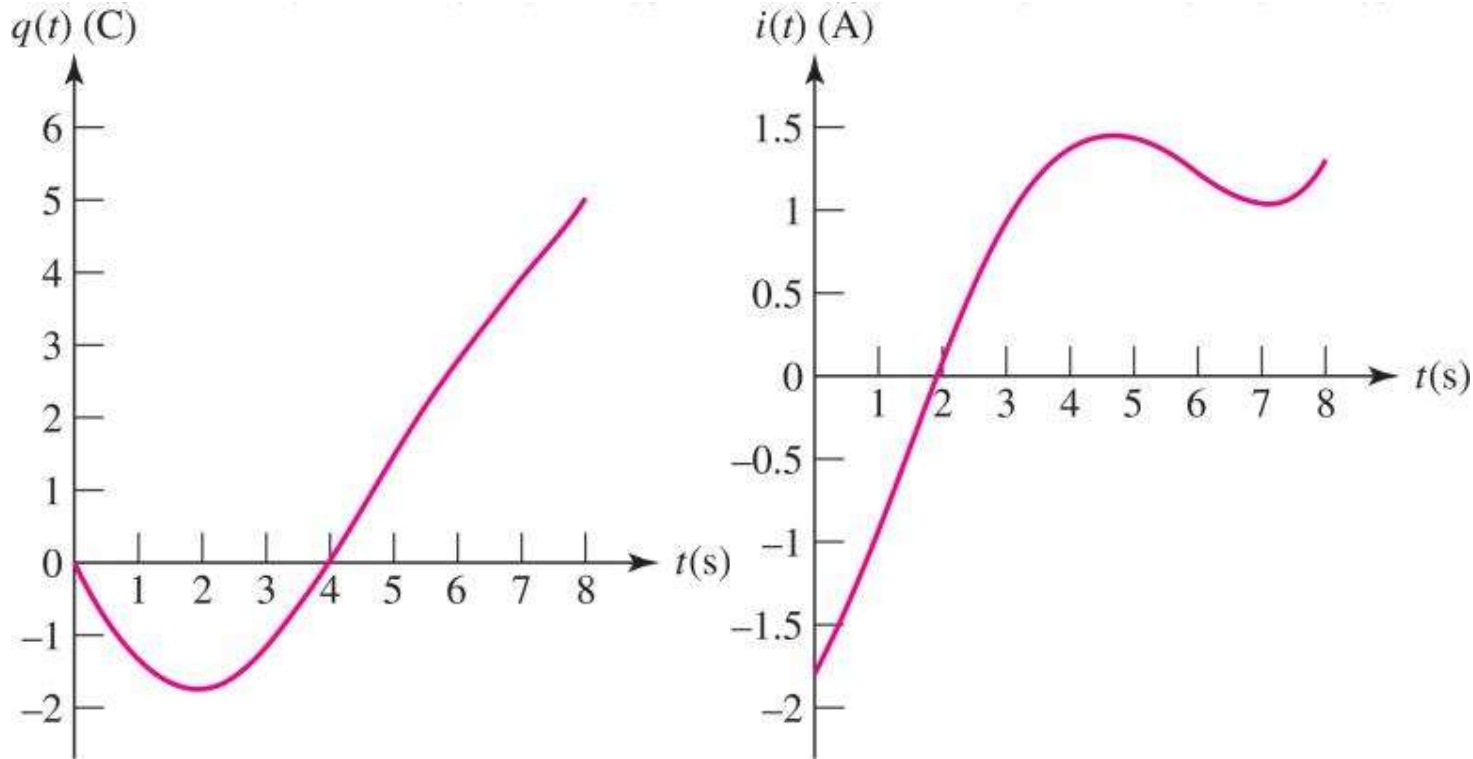

Voltage

- When 1 J of work is required to move 1 C of charge from A to B, there is a voltage of 1 volt between A and B.
- Voltage (V or v) across an element requires both a magnitude and a polarity.
- Example: (a)=(b), (c)=(d)

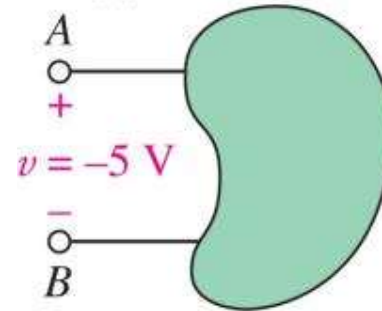

(a)

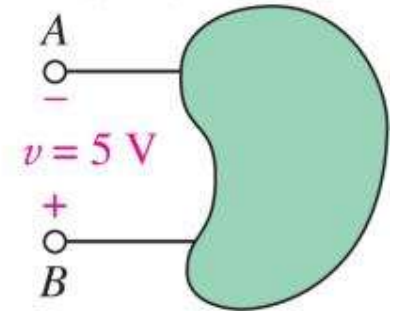

(b)

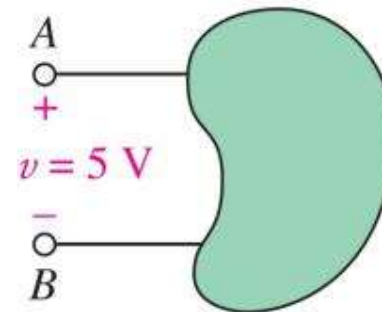

(c)

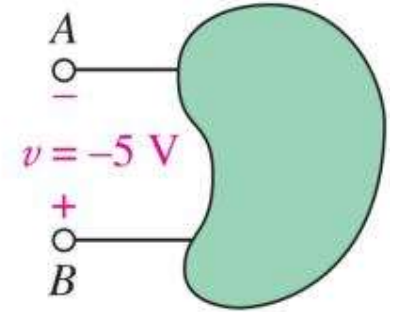

(d)

Power: $p = v i$

The power required to push a current i (C/s) into a voltage v (J/C) is $p = v i$ (J/s = W).

When power is positive, the element is *absorbing* energy.

When power is negative, the element is *supplying* energy.

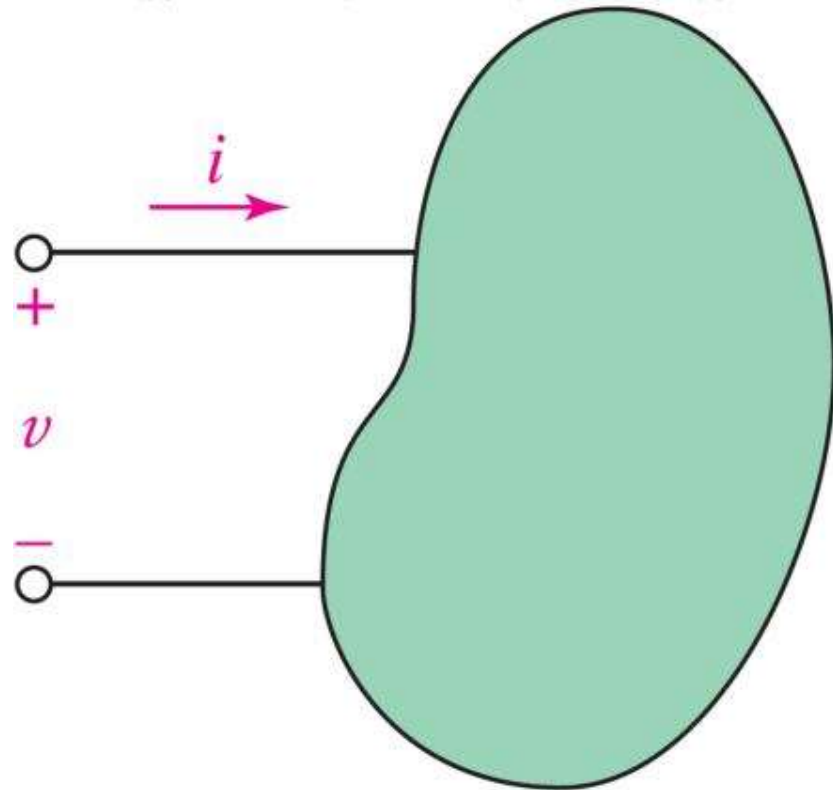

Example: Power

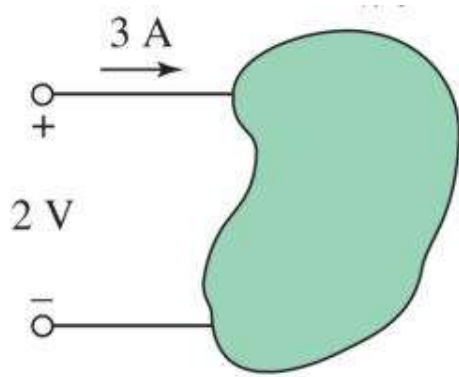

(a)

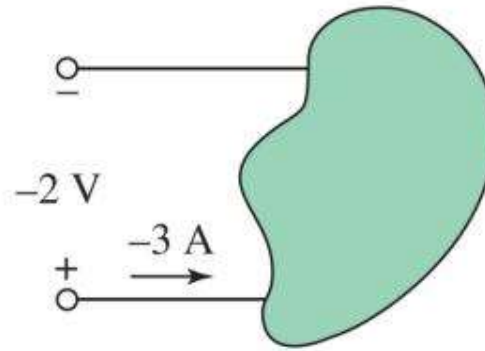

(b)

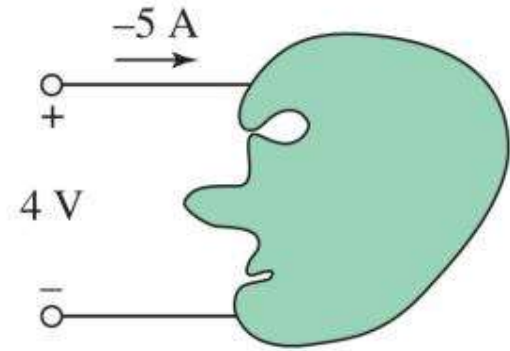

(c)

How much power is absorbed by the three elements above?

$$P_a = +6 \text{ W}, P_b = +6 \text{ W}, P_c = -20 \text{ W}.$$

(Note: (c) is actually supplying power)

Circuit Elements

- ▶ A circuit element usually has two terminals (sometimes three or more).
- ▶ The relationship between the voltage v across the terminals and the current i through the device defines the circuit element model.

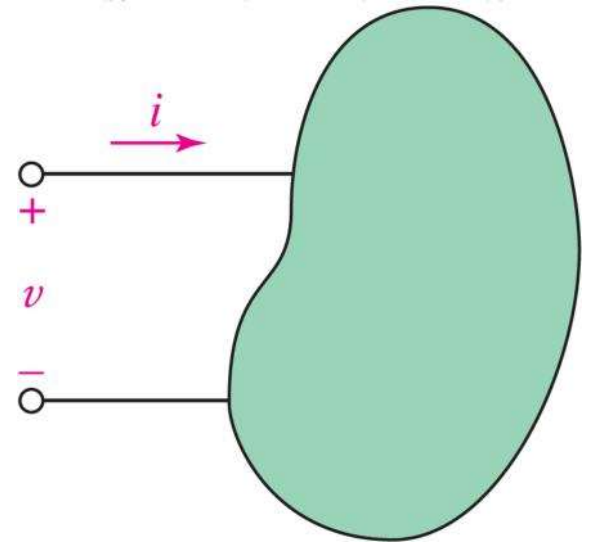

Voltage Sources

- ▶ An ideal voltage source is a circuit element that will maintain the specified voltage v_s across its terminals.
- ▶ The current will be determined by other circuit elements.

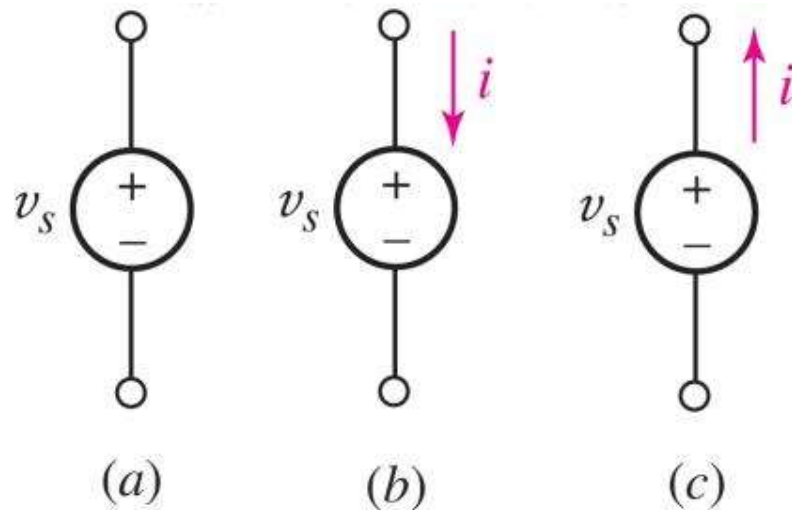

Current Sources

- ▶ An ideal current source is a circuit element that maintains the specified current flow i_s through its terminals.
- ▶ The voltage is determined by other circuit elements.

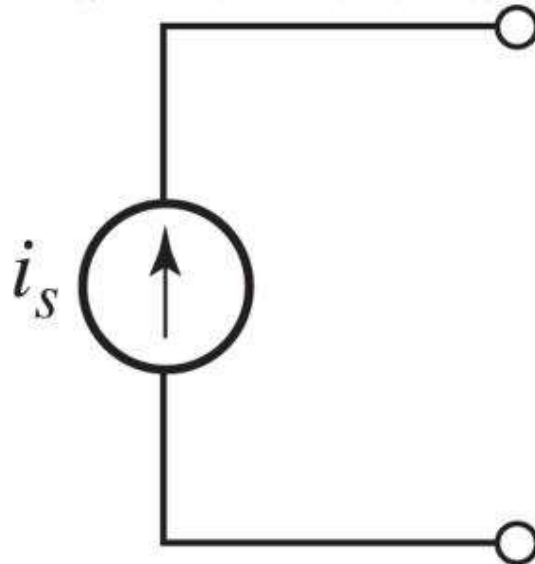

Battery as Voltage Source

- A voltage source is an idealization (no limit on current) and generalization (voltage can be time-varying) of a battery.
- A battery supplies a constant “dc” voltage V but in practice a battery has a maximum power.

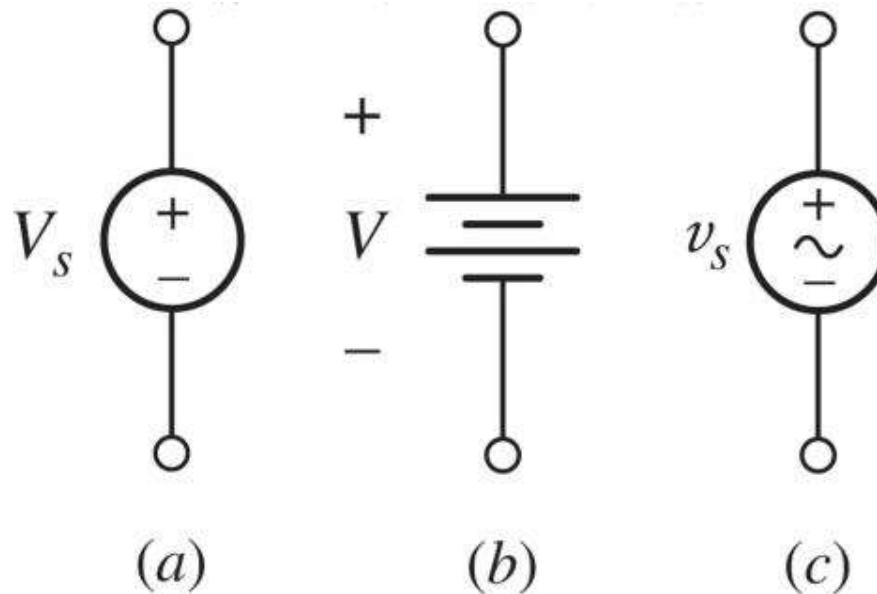

Dependent Sources

Dependent current sources (a) and (b) maintain a *current* specified by another circuit variable.

Dependent voltage sources (c) and (d) maintain a *voltage* specified by another circuit variable.

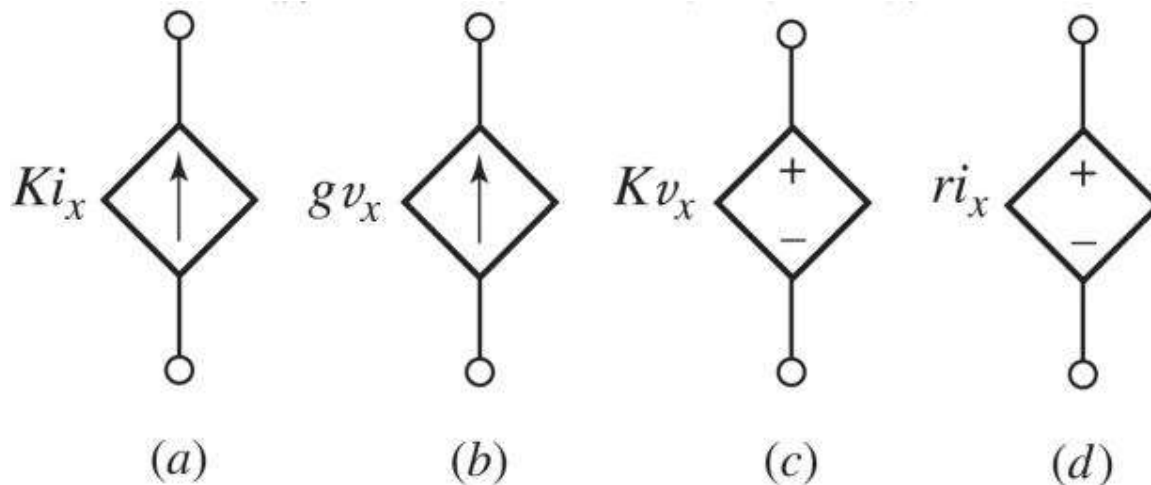

Example: Dependent Sources

Find the voltage v_L in the circuit below.

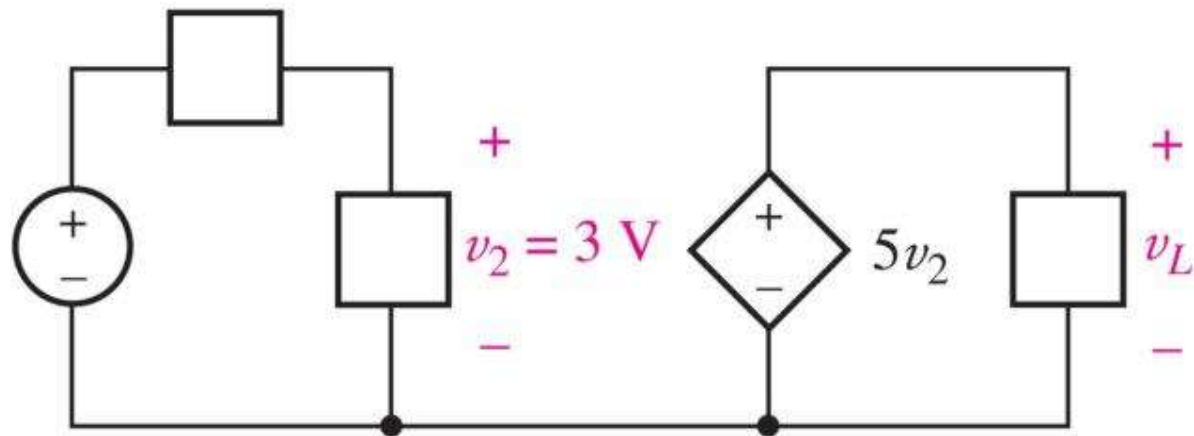

Ohm's Law: Resistance

- ▶ A (linear) resistor is an element for which
 - ▶ $v=iR$
- ▶ where the constant R is a resistance.
- ▶ The equation is known as “Ohm's Law.”
- ▶ The unit of resistance is ohm (Ω).

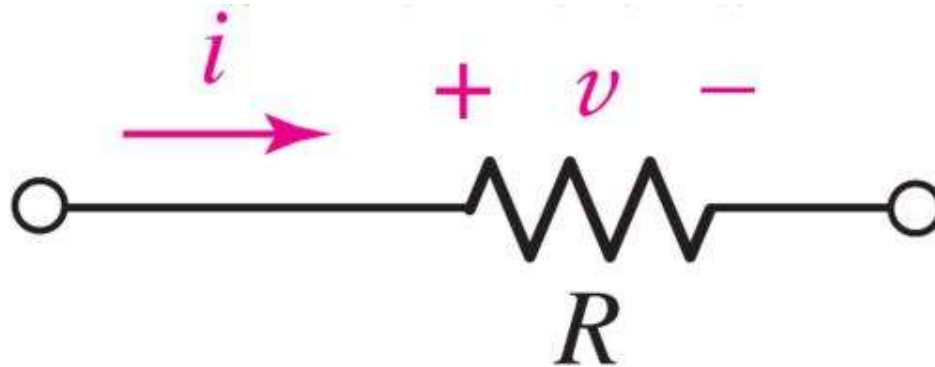

Resistors

(a) typical resistors (b) power resistor
(c) a 10 T Ω resistor (d) circuit symbol

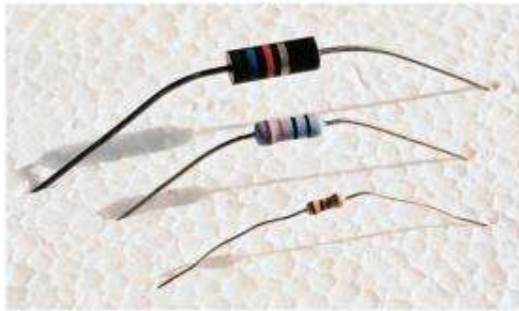

(a)



(b)

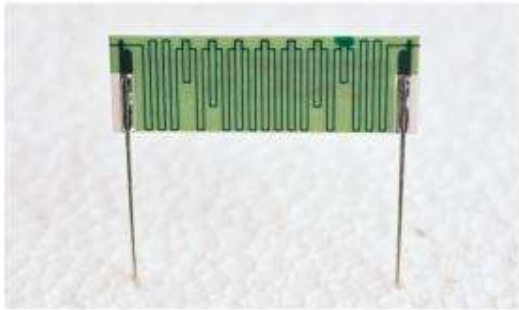

(c)

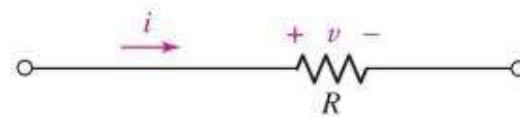

(d)

VI Graph for a Resistor

For a resistor, the plot of current versus voltage is a straight line:

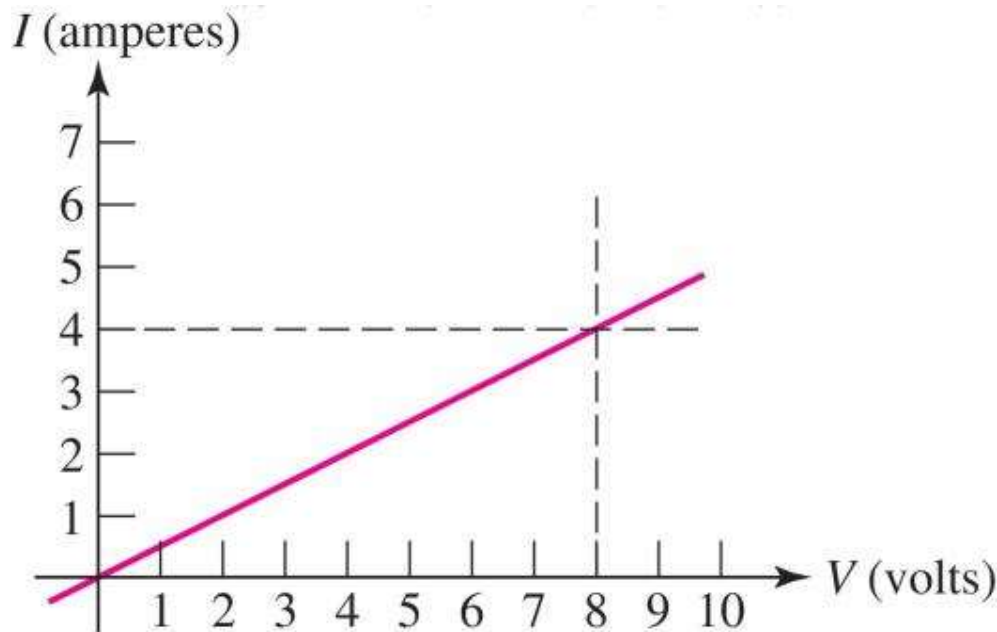

In this example, the slope is $4 \text{ A} / 8 \text{ V}$ or $0.5 \Omega^{-1}$.

This is the graph for a 2 ohm resistor.

Power Absorption

Resistors absorb power: since $v=iR$

$$p=vi = v^2/R = i^2R$$

Positive power means the device is absorbing energy.
Power is always positive for a resistor!

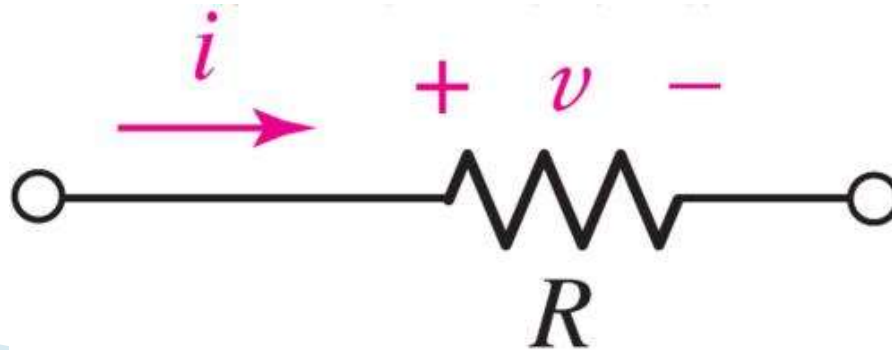

Example: Resistor Power

A $560\ \Omega$ resistor is connected to a circuit which causes a current of $42.4\ \text{mA}$ to flow through it.

Calculate the voltage across the resistor and the power it is dissipating.

$$v = iR = (0.0424)(560) = 23.7\ \text{V}$$

$$p = i^2R = (0.0424)^2(560) = 1.007\ \text{W}$$

Wire Gauge and Resistivity

The resistance of a wire is determined by the resistivity of the conductor as well as the geometry:

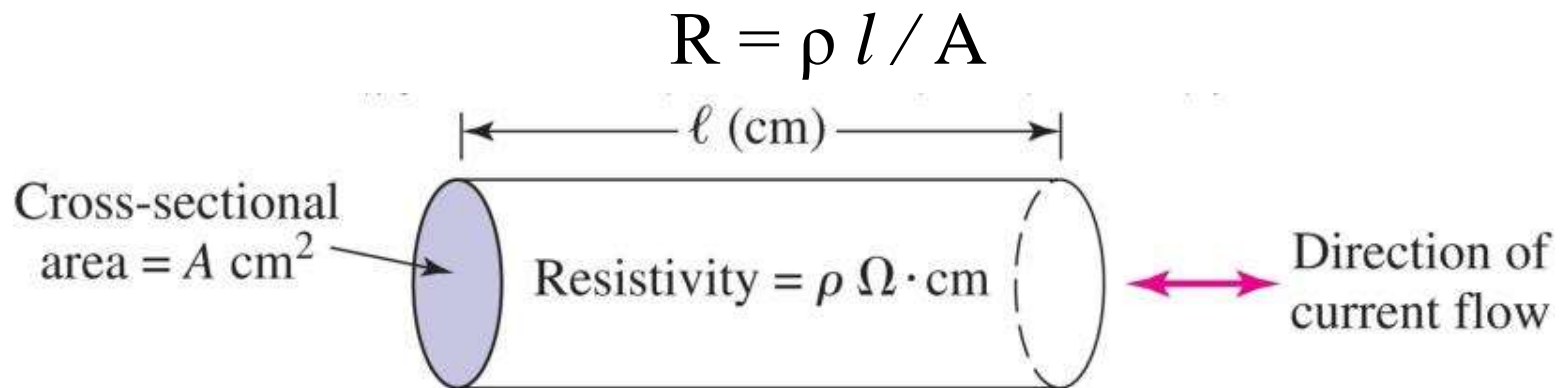

[In most cases, the resistance of wires can be assumed to be 0 ohms.]

Conductance

- ✘ We sometimes prefer to work with *the reciprocal of resistance* ($1/R$), which is called conductance (symbol G , unit siemens (S)).
- ✘ A resistor R has conductance $G=1/R$.
- ✘ The i - v equation (i.e. Ohm's law) can be written as

$$i = Gv$$

Open and Short Circuits

- ▶ An open circuit between A and B means $i=0$.
- ▶ *Voltage across* an open circuit: any value.
- ▶ An open circuit is equivalent to $R = \infty \Omega$.

- ▶ A short circuit between A and B means $v=0$.
- ▶ *Current through* a short circuit: any value.
- ▶ A short circuit is equivalent to $R = 0 \Omega$.

Circuit Analysis Basics

- × Fundamental elements
 - + Resistor
 - + Voltage Source
 - + Current Source
 - + Air
 - + Wire
- × Kirchhoff's Voltage and Current Laws
- × Resistors in Series
- × Voltage Division

Voltage and Current

- ✦ Voltage is the difference in electric potential between two points. To express this difference, we label a voltage with a “+” and “-” :

Here, V_1 is the potential at “a” minus the potential at “b”, which is -1.5 V.

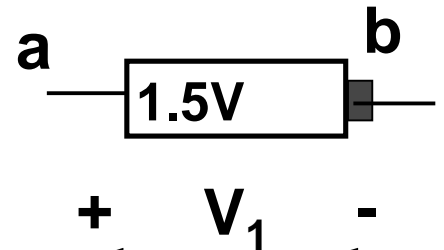

- ✦ Current is the flow of positive charge. Current has a value and a direction, expressed by an arrow:

Here, i_1 is the current that flows right;

i_1 is negative if current actually flows left.

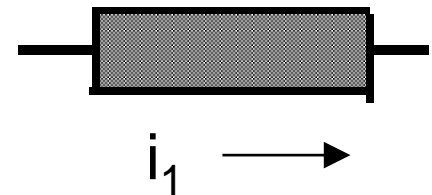

- ✦ These are ways to place a frame of reference in your analysis.

Basic Circuit Elements

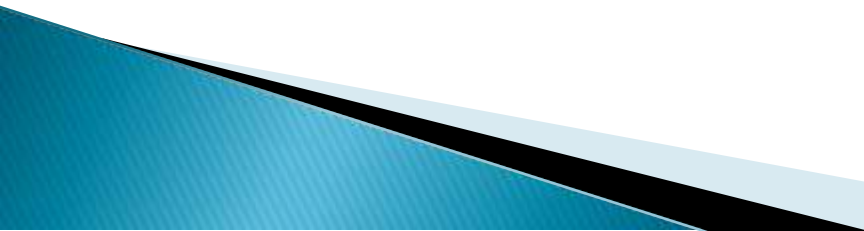
- × Resistor
 - + Current is proportional to voltage (linear)
 - × Ideal Voltage Source
 - + Voltage is a given quantity, current is unknown
 - × Wire (Short Circuit)
 - + Voltage is zero, current is unknown
 - × Ideal Current Source
 - + Current is a given quantity, voltage is unknown
 - × Air (Open Circuit)
 - + Current is zero, voltage is unknown
- 

Resistor

- ✘ The resistor has a current-voltage relationship called Ohm's law:

$$v = i R$$

where R is the resistance in Ω , i is the current in A, and v is the voltage in V, with reference directions as pictured.

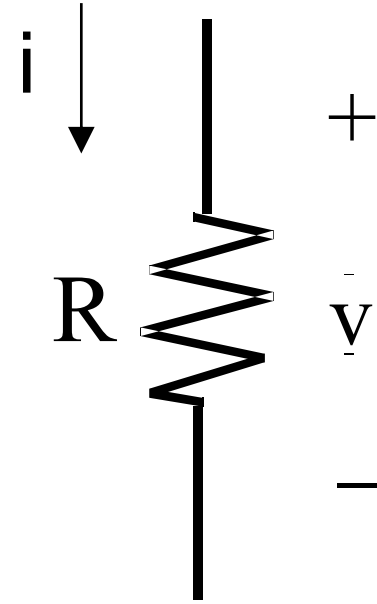

- ✘ If R is given, once you know i , it is easy to find v and vice-versa.
- ✘ Since R is never negative, a resistor always absorbs power...

Ideal Voltage Source

- ✘ The ideal voltage source explicitly defines the voltage between its terminals.
 - + Constant (DC) voltage source: $V_s = 5 \text{ V}$
 - + Time-Varying voltage source: $V_s = 10 \sin(t) \text{ V}$
 - + Examples: batteries, wall outlet, function generator, ...
- ✘ The ideal voltage source does not provide any information about the current flowing through it.
- ✘ The current through the voltage source is defined by the rest of the circuit to which the source is attached. Current cannot be determined by the value of the voltage.
- ✘ Do not assume that the current is zero.

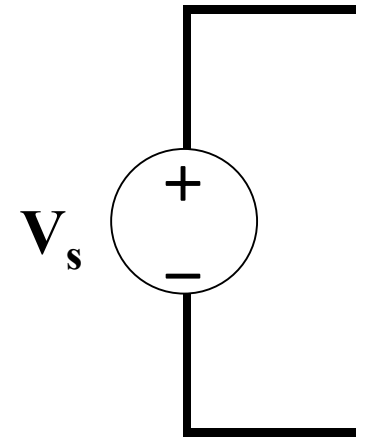

Wire

- × Wire has a very small resistance.
- × For simplicity, we will idealize wire in the following way: the potential at all points on a piece of wire is the same, regardless of the current going through it.
 - + Wire is a 0 V voltage source
 - + Wire is a 0 Ω resistor
- × This idealization (and others) can lead to contradictions on paper—and smoke in lab.

Ideal Current Source

- ✘ The ideal current source sets the value of the current running through it.
 - + Constant (DC) current source: $I_S = 2 \text{ A}$
 - + Time-Varying current source: $I_S = -3 \sin(t) \text{ A}$
 - + Examples: few in real life!
- ✘ The ideal current source has known current, but unknown voltage.
- ✘ The voltage across the voltage source is defined by the rest of the circuit to which the source is attached.
- ✘ Voltage cannot be determined by the value of the current.
- ✘ Do not assume that the voltage is zero!

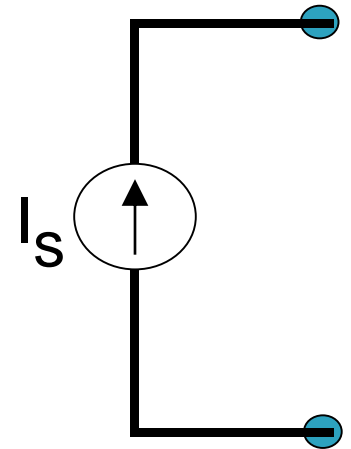

Air

- ✘ Many of us at one time, after walking on a carpet in winter, have touched a piece of metal and seen a blue arc of light.
- ✘ That arc is current going through the air. So is a bolt of lightning during a thunderstorm.
- ✘ However, these events are unusual. Air is usually a good insulator and does not allow current to flow.
- ✘ For simplicity, we will idealize air in the following way:
 - current never flows through air (or a hole in a circuit), regardless of the potential difference (voltage) present.
 - + Air is a 0 A current source
 - + Air is a very very big (infinite) resistor
- ✘ There can be nonzero voltage over air or a hole in a circuit

I-V Relationships Graphically

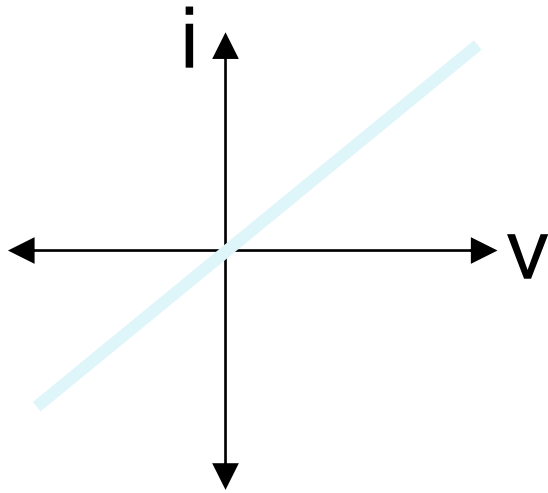

Resistor: Line through origin with slope $1/R$

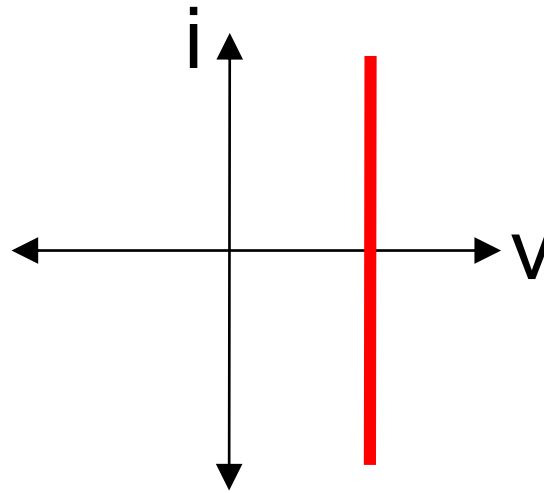

Ideal Voltage Source: Vertical line

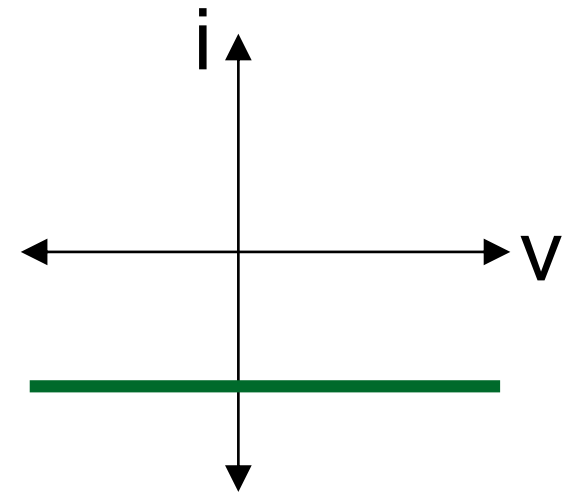

Ideal Current Source: Horizontal line

Wire: Vertical line through origin

Air: Horizontal line through origin

Kirchhoff's Laws

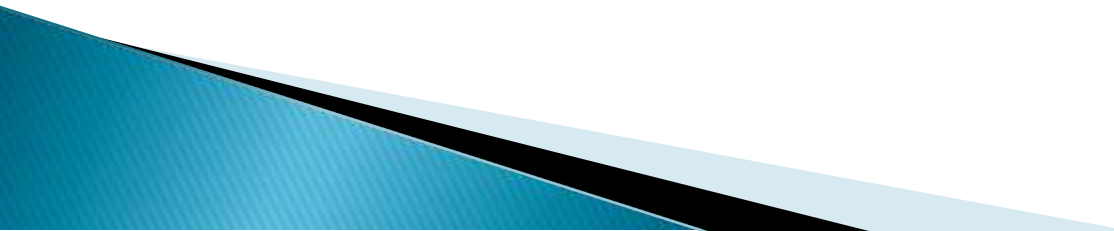
- ✘ The I-V relationship for a device tells us how current and voltage are related within that device.
 - ✘ Kirchhoff's laws tell us how voltages relate to other voltages in a circuit, and how currents relate to other currents in a circuit.
 - ✘ KVL: The sum of voltage drops around a closed path must equal zero.
 - ✘ KCL: The sum of currents leaving a closed surface or point must equal zero.
- 

Kirchhoff's Voltage Law (KVL)

- ✘ Suppose I add up the potential drops around the closed path, from “a” to “b” to “c” and back to “a”.
- ✘ Since I end where I began, the total drop in potential I encounter along the path must be zero: $V_{ab} + V_{bc} + V_{ca} = 0$
- ✘ It would not make sense to say, for example, “b” is 1 V lower than “a”, “c” is 2 V lower than “b”, and “a” is 3 V lower than “c”. I would then be saying that “a” is 6 V lower than “a”, which is nonsense!
- ✘ We can use potential rises throughout instead of potential drops; this is an alternative statement of KVL.

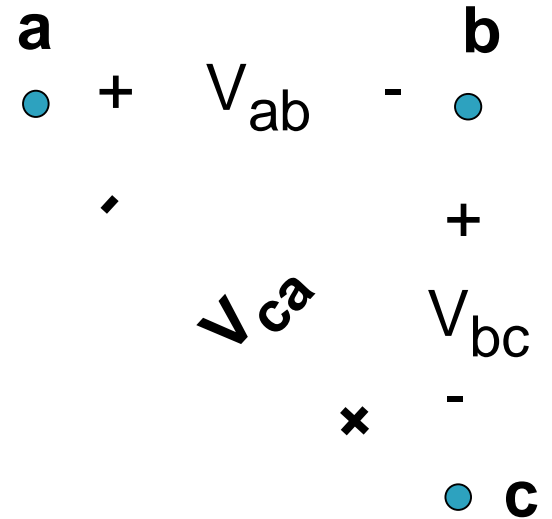

KVL Tricks

- ▶ A voltage rise is a negative voltage drop.

Along a path, I might encounter a voltage which is labeled as a voltage drop (in the direction I'm going). The sum of these voltage drops must equal zero.

I might encounter a voltage which is labeled as a voltage rise (in the direction I'm going). This rise can be viewed as a “negative drop”.

Rewrite:

- ▶ Look at the first sign you encounter on each element when tracing the closed path. If it is a “-”, it is a voltage rise and you will insert a “-” to rewrite as a drop.

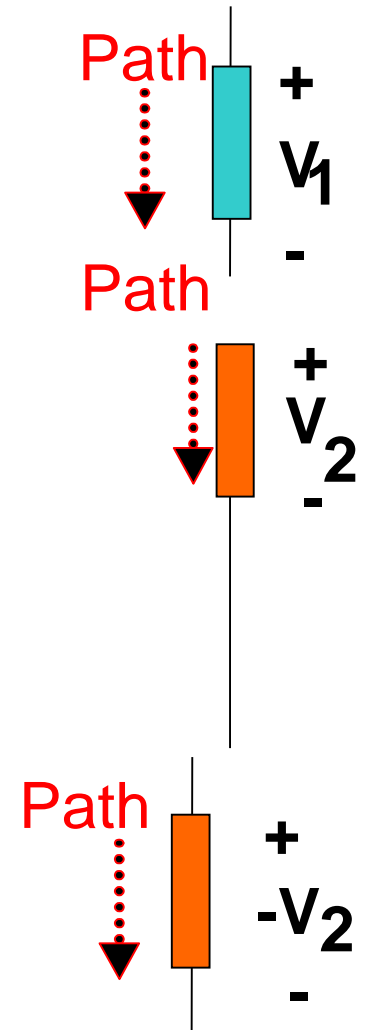

Writing KVL Equations

What does KVL say about the voltages along these 3 paths?

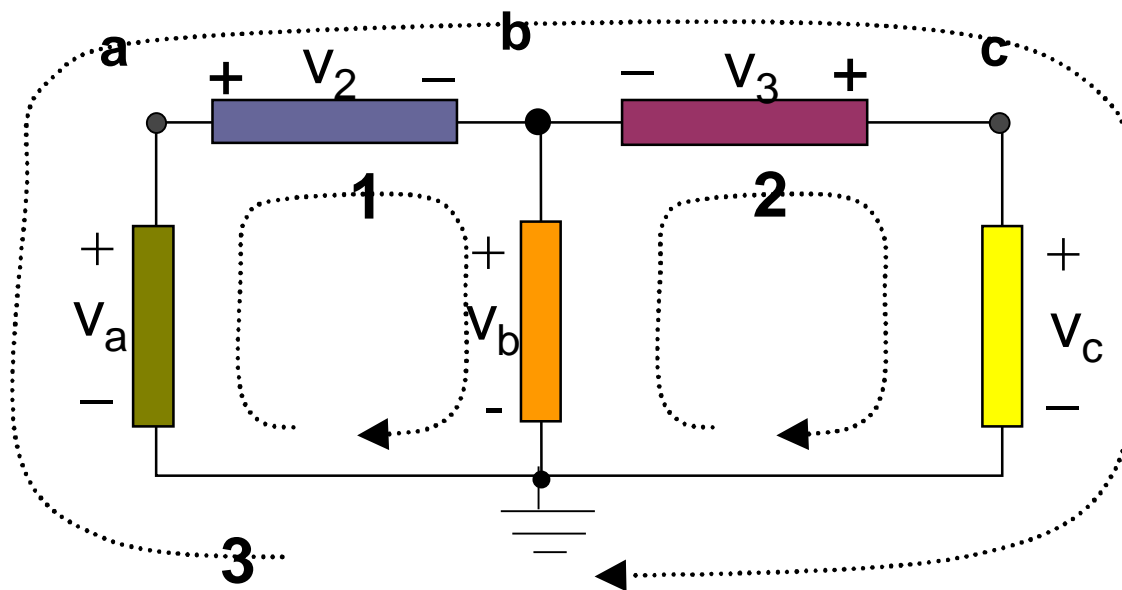

Path 1:
$$-V_a + V_2 + V_b = 0$$

Path 2:
$$-V_b - V_3 + V_c = 0$$

Path 3:
$$-V_a + V_2 - V_3 + V_c = 0$$

Elements in Parallel

- ▶ KVL tells us that any set of elements which are **connected at both ends** carry the **same voltage**.
- ▶ We say these elements are **in parallel**.

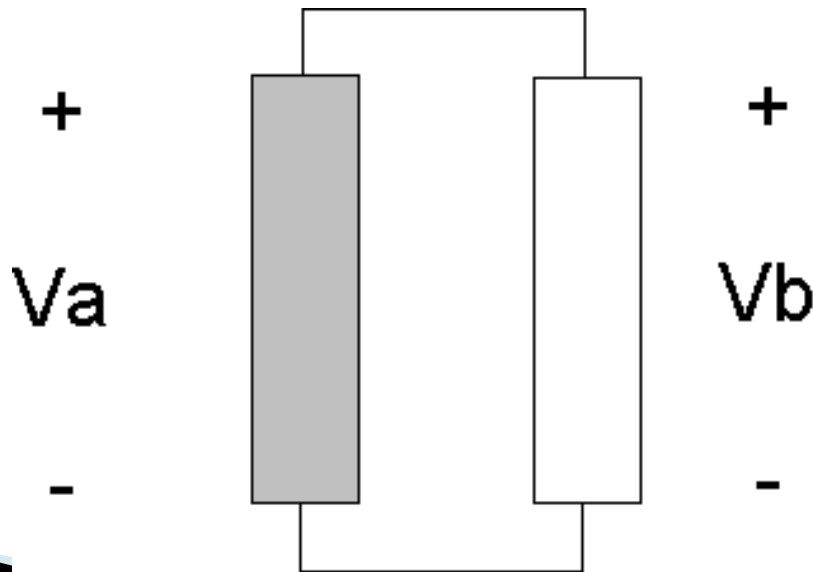

**KVL clockwise,
start at top:**

$$V_b - V_a = 0$$

$$V_a = V_b$$

Kirchhoff's Current Law (KCL)

- ▶ Electrons don't just disappear or get trapped (in our analysis).
- ▶ Therefore, the sum of all current entering a closed surface or point must equal zero—whatever goes in must come out.
- ▶ Remember that current leaving a closed surface can be interpreted as a negative current entering:

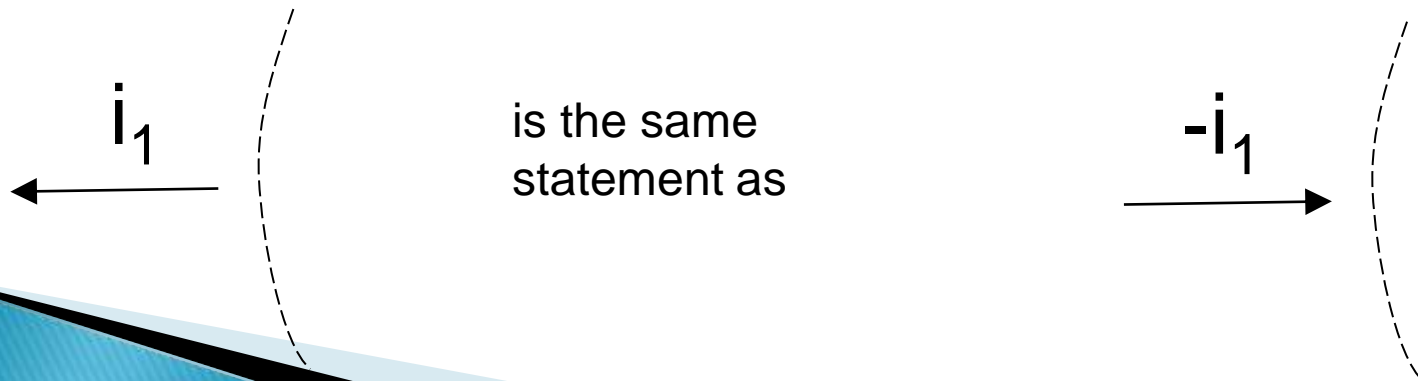

KCL Equations

In order to satisfy KCL, what is the value of i ?

KCL says:

$$24 \mu\text{A} + -10 \mu\text{A} + (-)-4 \mu\text{A} + -i = 0$$

$$18 \mu\text{A} - i = 0$$

$$i = 18 \mu\text{A}$$

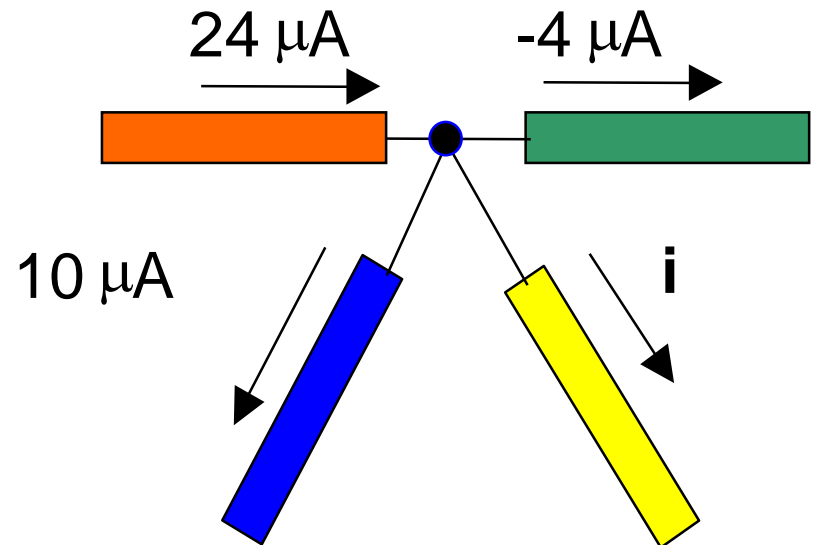

Elements in Series

- ▶ Suppose two elements are connected with **nothing coming off in between**.
- ▶ KCL says that the elements carry the **same current**.
- ▶ We say these elements are **in series**.

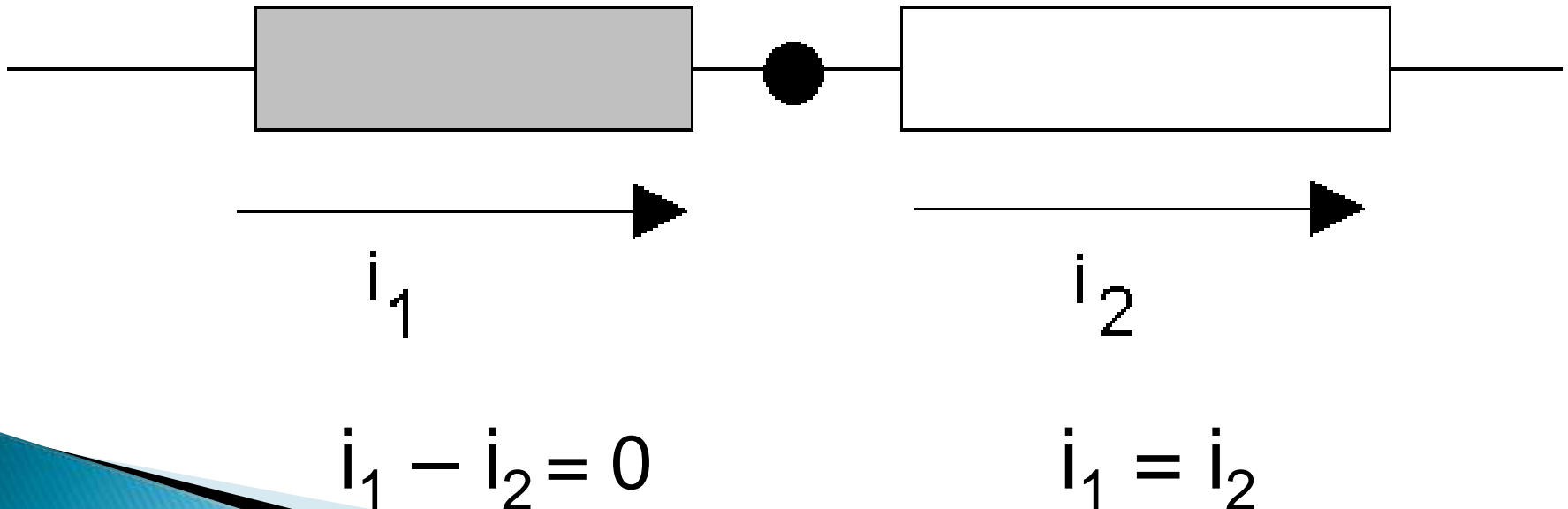

Resistors in Series

- ✘ Consider resistors in series. This means they are attached end-to-end, with nothing coming off in between.

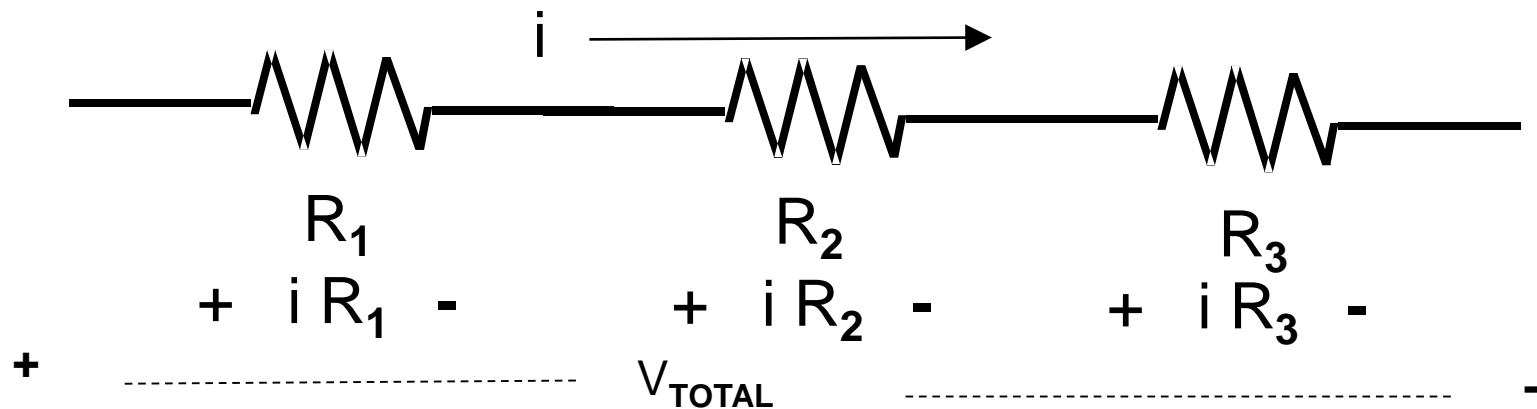

- ✘ Each resistor has the same current (labeled i).
- ✘ Each resistor has voltage iR , given by Ohm's law.
- ✘ The total voltage drop across all 3 resistors is
$$V_{TOTAL} = i R_1 + i R_2 + i R_3 = i (R_1 + R_2 + R_3)$$

Resistors in Series

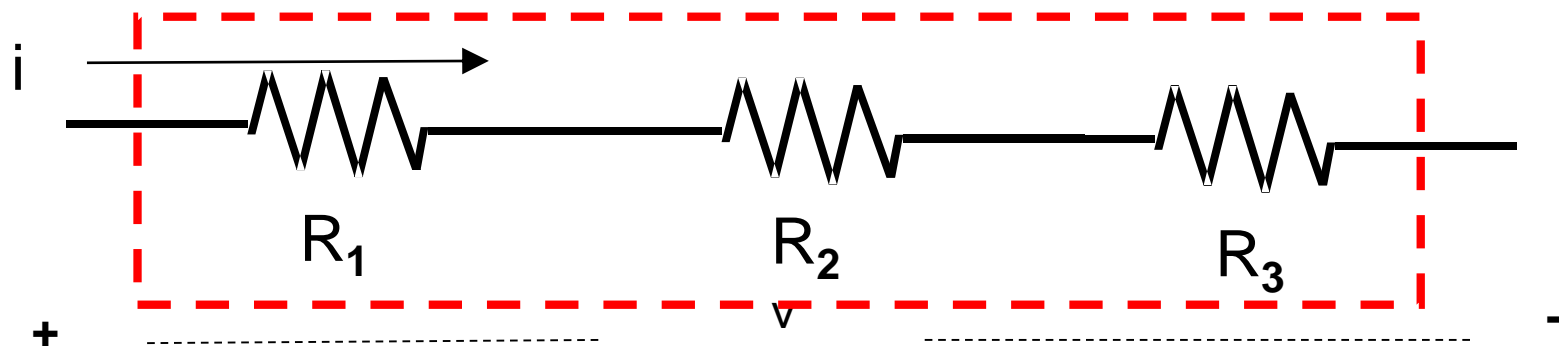

- ✘ When we look at all three resistors together as one unit, we see that they have the same I-V relationship as one resistor, whose value is the sum of the resistances:
- ✘ So we can treat these resistors as just one **equivalent resistance**, as long as we are not interested in the individual voltages. Their effect on the rest of the circuit is the same, whether lumped together or not.

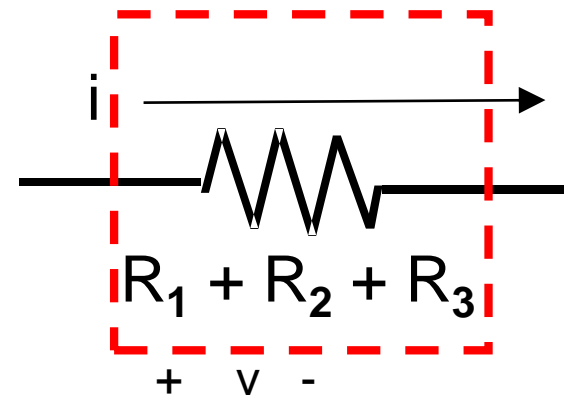

Voltage Division

- ✦ If we know the total voltage over a series of resistors, we can easily find the individual voltages over the individual resistors.

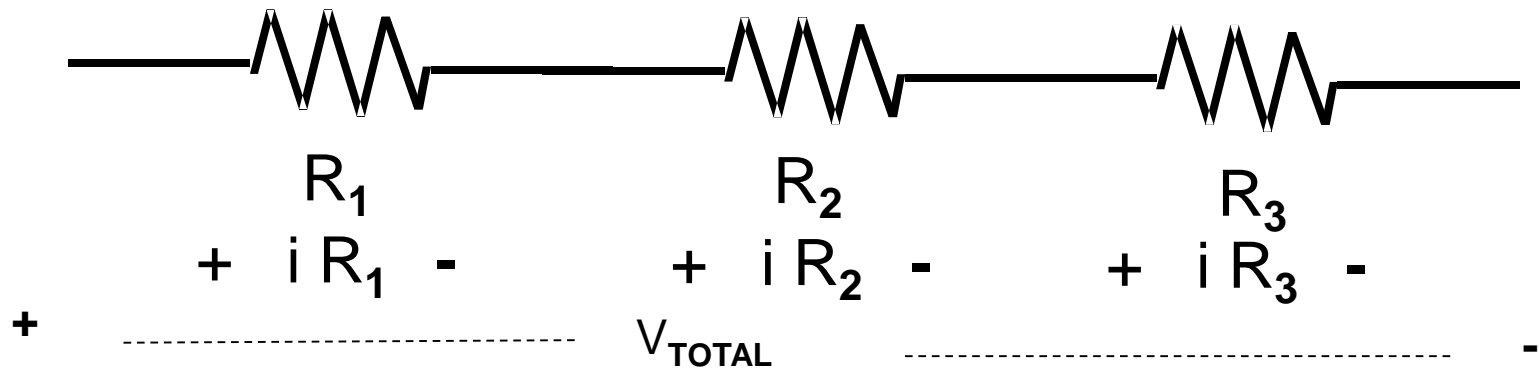

- ✦ Since the resistors in series have the same current, the voltage divides up among the resistors in proportion to each individual resistance.

Voltage Division

- ✦ For example, we know

$$i = V_{\text{TOTAL}} / (R_1 + R_2 + R_3)$$

so the voltage over the **first resistor** is

$$i R_1 = R_1 V_{\text{TOTAL}} / (R_1 + R_2 + R_3)$$

$$= V_{\text{TOTAL}} \frac{R_1}{R_1 + R_2 + R_3}$$

- ✦ To find the voltage over an individual resistance in series, take the total series voltage and multiply by the individual resistance over the total resistance.

MEASURING INSTRUMENTS

MEASURING INSTRUMENTS

“The device used for comparing the unknown quantity with the unit of measurement or standard quantity is called a Measuring Instrument.”

(OR)

“An instrument may be defined as a machine or system which is designed to maintain functional relationship between prescribed properties of physical variables & could include means of communication to human observer.”

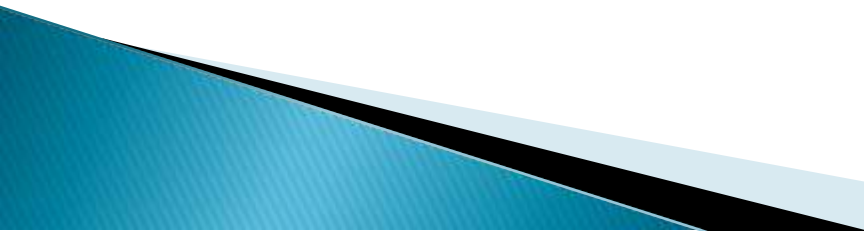

CLASSIFICATION OF INSTRUMENTS

Electrical instruments may be divided into two categories, that are;

1. Absolute instruments,
2. Secondary instruments.

-Absolute instruments gives the quantity to be measured in term of instrument constant & its deflection.

-In Secondary instruments the deflection gives the magnitude of electrical quantity to be measured directly. These instruments are required to be calibrated by comparing with another standard instrument before putting into use.

CLASSIFICATION OF INSTRUMENTS



CLASSIFICATION OF INSTRUMENTS

Electrical measuring instruments may also be classified according to the kind of quantity, kind of current, principle of operation of moving system.

CLASSIFICATION OF SECONDARY INSTRUMENTS

Secondary instruments can be classified into three types;

- i. Indicating instruments;
- ii. Recording instruments;
- iii. Integrating instruments.

CLASSIFICATION OF SECONDARY INSTRUMENTS

- Indicating Instruments:

It indicates the magnitude of an electrical quantity at the time when it is being measured. The indications are given by a pointer moving over a graduated dial.

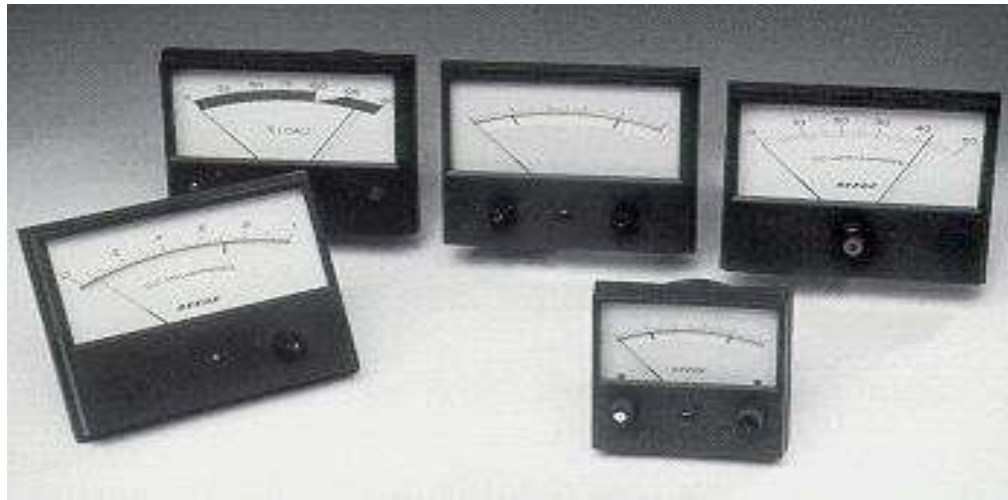

CLASSIFICATION OF SECONDARY INSTRUMENTS

- Recording Instruments:

The instruments which keep a continuous record of the variations of the magnitude of an electrical quantity to be observed over a defined period of time.



CLASSIFICATION OF SECONDARY INSTRUMENTS

- Integrating Instruments:

The instruments which measure the total amount of either quantity of electricity or electrical energy supplied over a period of time. For example energy meters.



ESSENTIALS OF INDICATING INSTRUMENTS

A defined above, indicating instruments are those which indicate the value of quantity that is being measured at the time at which it is measured. Such instruments consist essentially of a pointer which moves over a calibrated scale

& which is attached to a moving system pivoted in bearing. The moving system is subjected to the following three torques:

1. A deflecting (or operating) torque;
2. A controlling (or restoring) torque;

DEFLECTING TORQUE

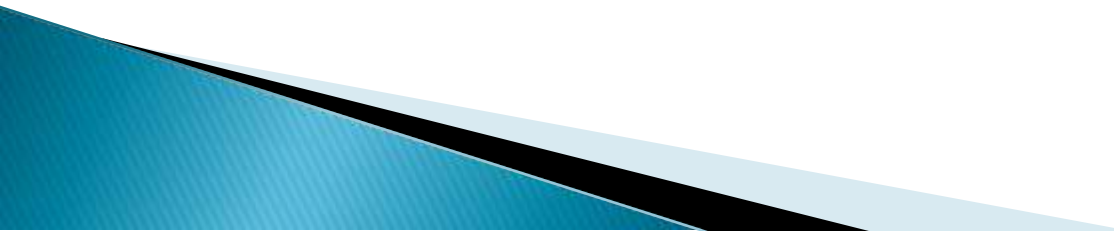
- The deflecting torque is produced by making one of the magnetic, heating, chemical, electrostatic and electromagnetic induction effect of current or voltage and cause the moving system of the instrument to move from its zero position.
 - The method of producing this torque depends upon the type of instrument.
- 

CONTROLLING TORQUE

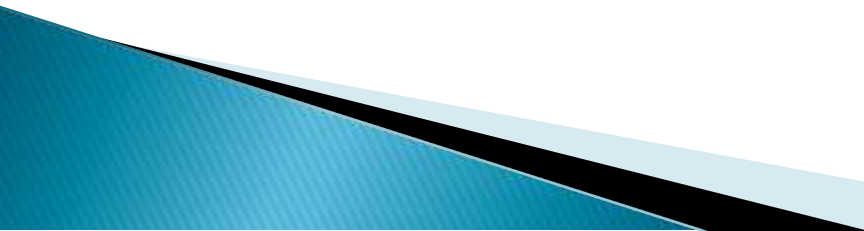
- The magnitude of the moving system would be some what indefinite under the influence of deflecting torque, unless the controlling torque existed to oppose the deflecting torque.
 - It increases with increase in deflection of moving system.
 - Under the influence of controlling torque the pointer will return to its zero position on removing the source producing the deflecting torque.
 - Without controlling torque the pointer will swing at its maximum position & will not return to zero after removing the source.
- 

- **Controlling torque is produced either by spring or gravity control.**

Spring Control:

•When the pointer is deflected one spring unwinds itself while the other is twisted. This twist in the spring produces restoring (controlling) torque, which is proportional to the angle of deflection of the moving systems.

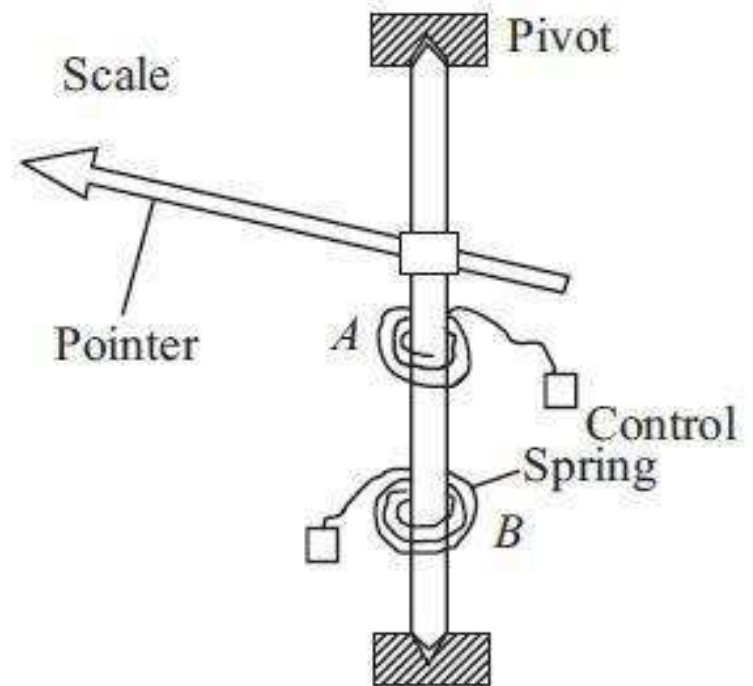

Spring Control

$$T_c \propto \theta$$

$$T_c = K_s \theta$$

$$T_d \propto I$$

$$T_d = K_s I$$

$$T_c = T_d$$

$$\theta = I$$

Gravity Control

- In gravity controlled instruments, *a small adjustable weight is attached to the spindle of the moving system* such that the deflecting torque produced by the instrument has to act against the action of gravity.
- Thus a controlling torque is obtained. This weight is called the *control weight*. Another adjustable weight is also attached is the *moving system for zero adjustment and balancing purpose*. This weight is called *Balance weight*.

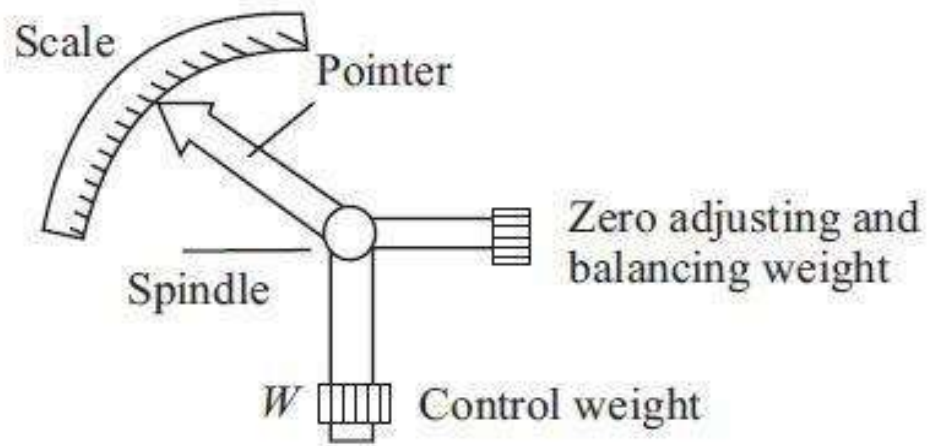

DAMPING TORQUE

- We have already seen that the moving system of the instrument will tend to move under the action of the deflecting torque.
 - But on account of the control torque, it will try to occupy a position of rest when the two torques are equal and opposite.
 - However, due to inertia of the moving system, the pointer will not come to rest immediately but oscillate about its final deflected position as shown in figure and takes appreciable time to come to steady state.
 - To overcome this difficulty a damping torque is to be developed by using a damping device attached to the moving system.

DAMPING TORQUE

- The damping torque is proportional to the speed of rotation of the moving system, that is

$$T_v = k_v \frac{d\theta}{dt}$$

where k_v = damping torque constant

$\frac{d\theta}{dt}$ = speed of rotation of the moving system

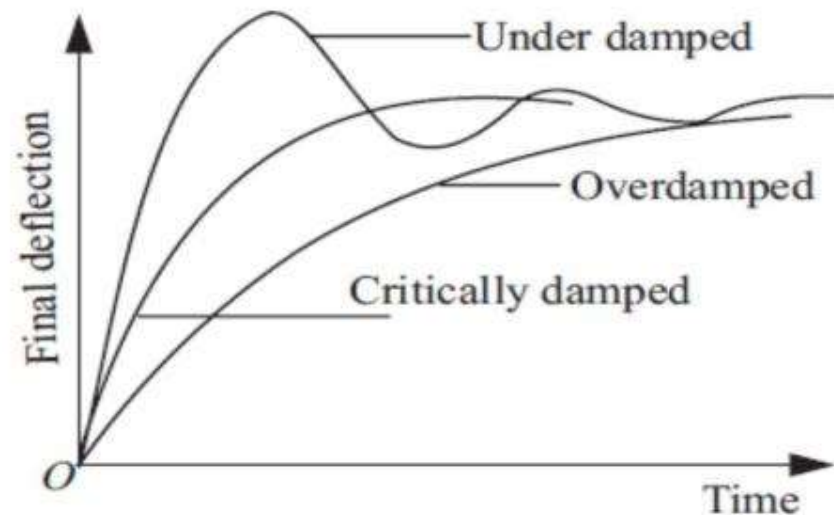

- Depending upon the degree of damping introduced in the moving system, the instrument may have any one of the

DAMPING TORQUE

1. Under damped condition:

- ▶ The response is oscillatory

2. Over damped condition:

- ▶ The response is sluggish and it rises very slowly from its zero position to final position.

3. Critically damped condition:

- ▶ When the response settles quickly without any oscillation, the system is said to be critically damped.
- ▶ The damping torque is produced by the following methods:

1. Air Friction Damping

2. Fluid Friction Damping

3. Eddy Current Damping

4. Electromagnetic

Moving-Coil instrument

- There are two types of moving coil instruments namely, permanent magnet moving coil type which can only be used for direct current, voltage measurements.
 - The dynamometer type which can be used on either direct or alternating current, voltage measurements.
- 

PERMANENT MAGNET MOVING COIL

“The principle operation of PMMC is based upon the principle of current carrying conductor is placed in a magnetic field it is acted upon by force which tends to move it.”

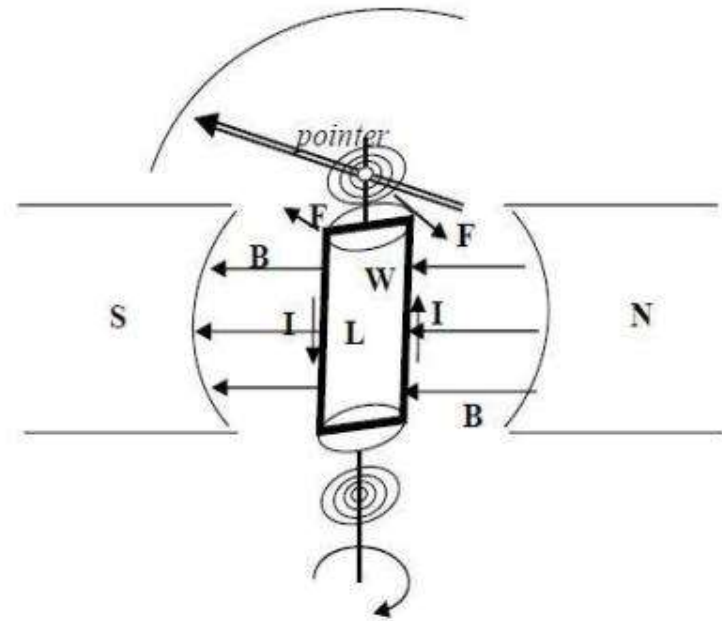

Moving-iron instrument

- An attraction type of moving-iron instrument is shown diagrammatically in Figure. When current flows in the solenoid, a pivoted soft-iron disc is attracted towards the solenoid and the movement causes a pointer to move across a scale.

In the repulsion type moving-iron instrument shown diagrammatically in Figure, two pieces of iron are placed inside the solenoid, one being fixed, and the other attached to the spindle carrying the pointer.

Moving-iron instrument

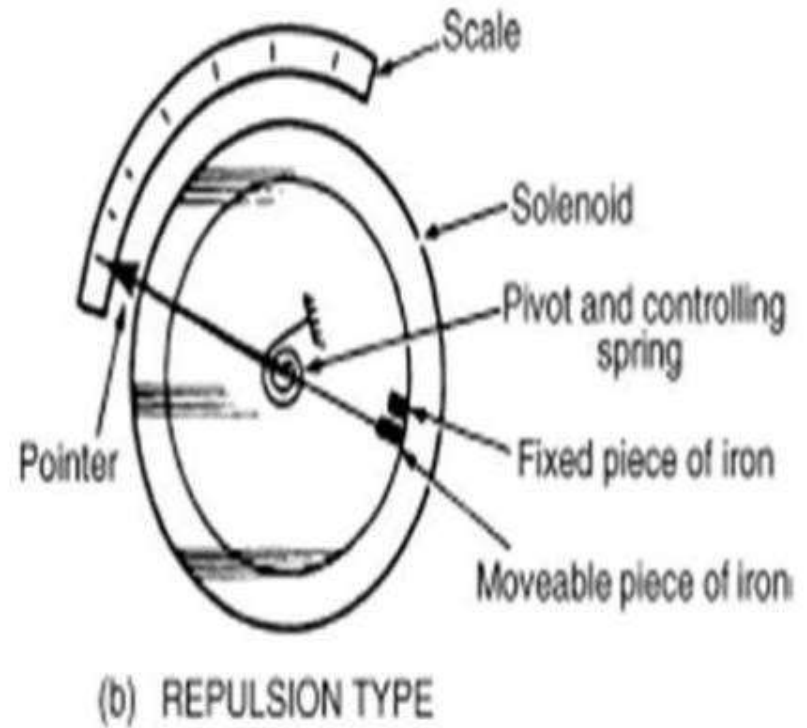
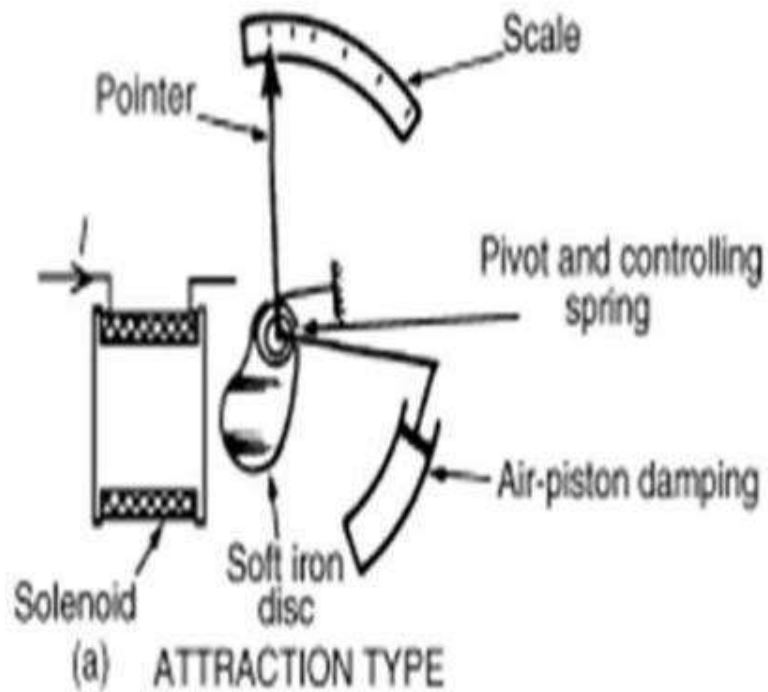

UNIT II

DC MACHINES

DC Generator

Mechanical energy is converted to electrical energy

Three requirements are essential

1. Conductors
2. Magnetic field
3. Mechanical energy

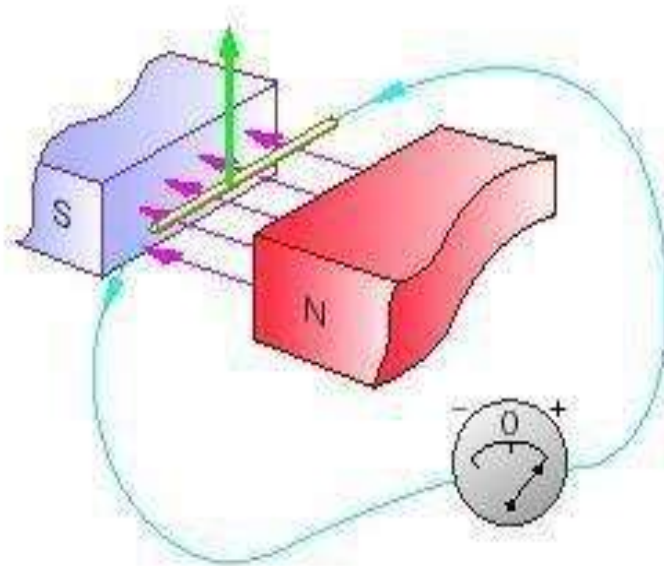

Working principle

- A generator works on the principles of
 - Faraday's law of electromagnetic induction.
 - Whenever a conductor is moved in the magnetic field , an emf is induced and the magnitude of the induced emf is directly proportional to the rate of change of flux linkage.
 - This emf causes a current flow if the conductor circuit is closed .
- 

Fleming's Right hand rule

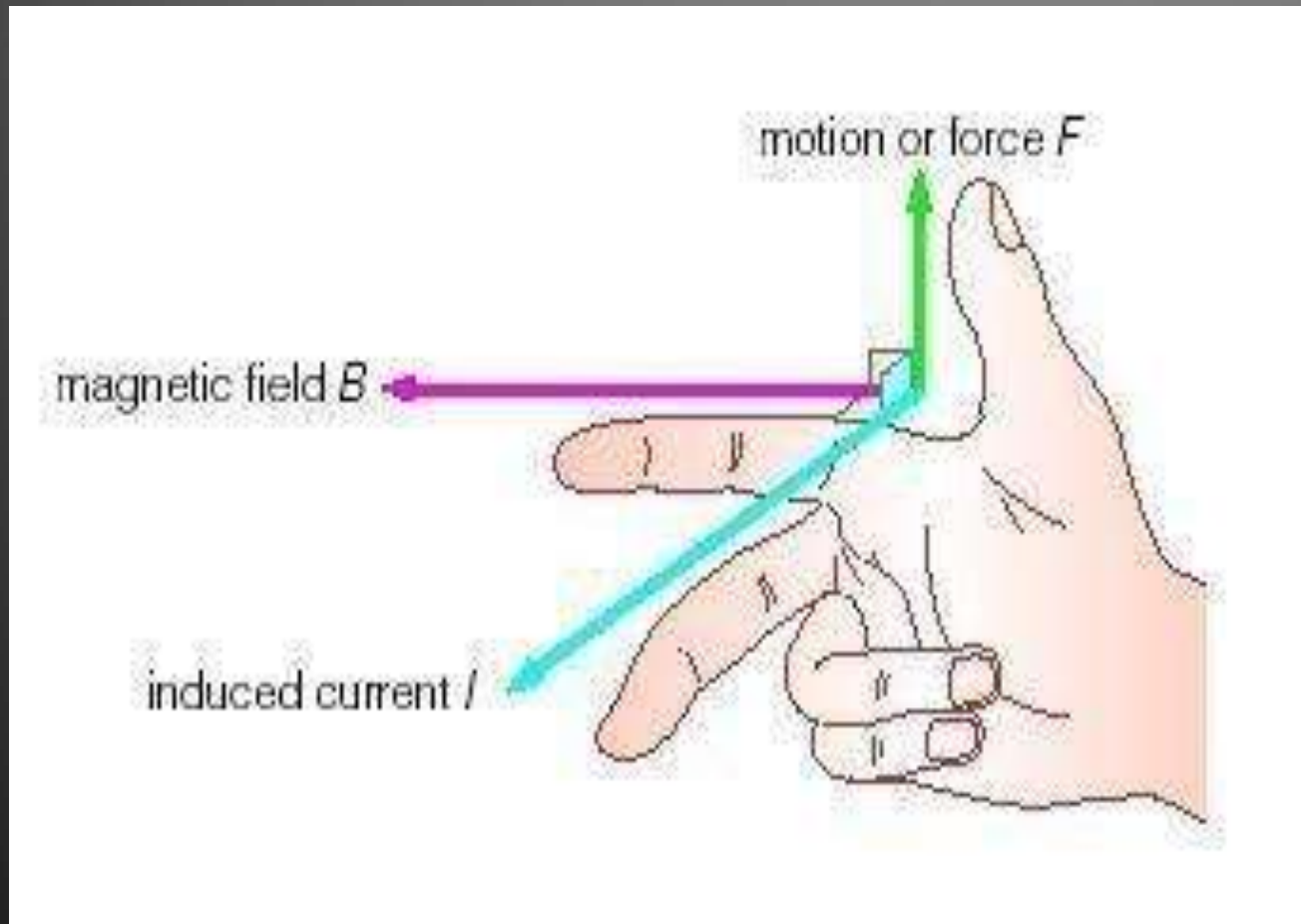

Fleming's Right hand rule

- Used to determine the direction of emf induced in a conductor for DC Generators
- The middle finger, the fore finger and thumb of the left hand are kept at right angles to one another.
- The fore finger represent the direction of magnetic field
- The thumb represent the direction of motion of the conductor
- The middle finger will indicate the direction of the inducted emf .
- **This rule is used in DC Generators**

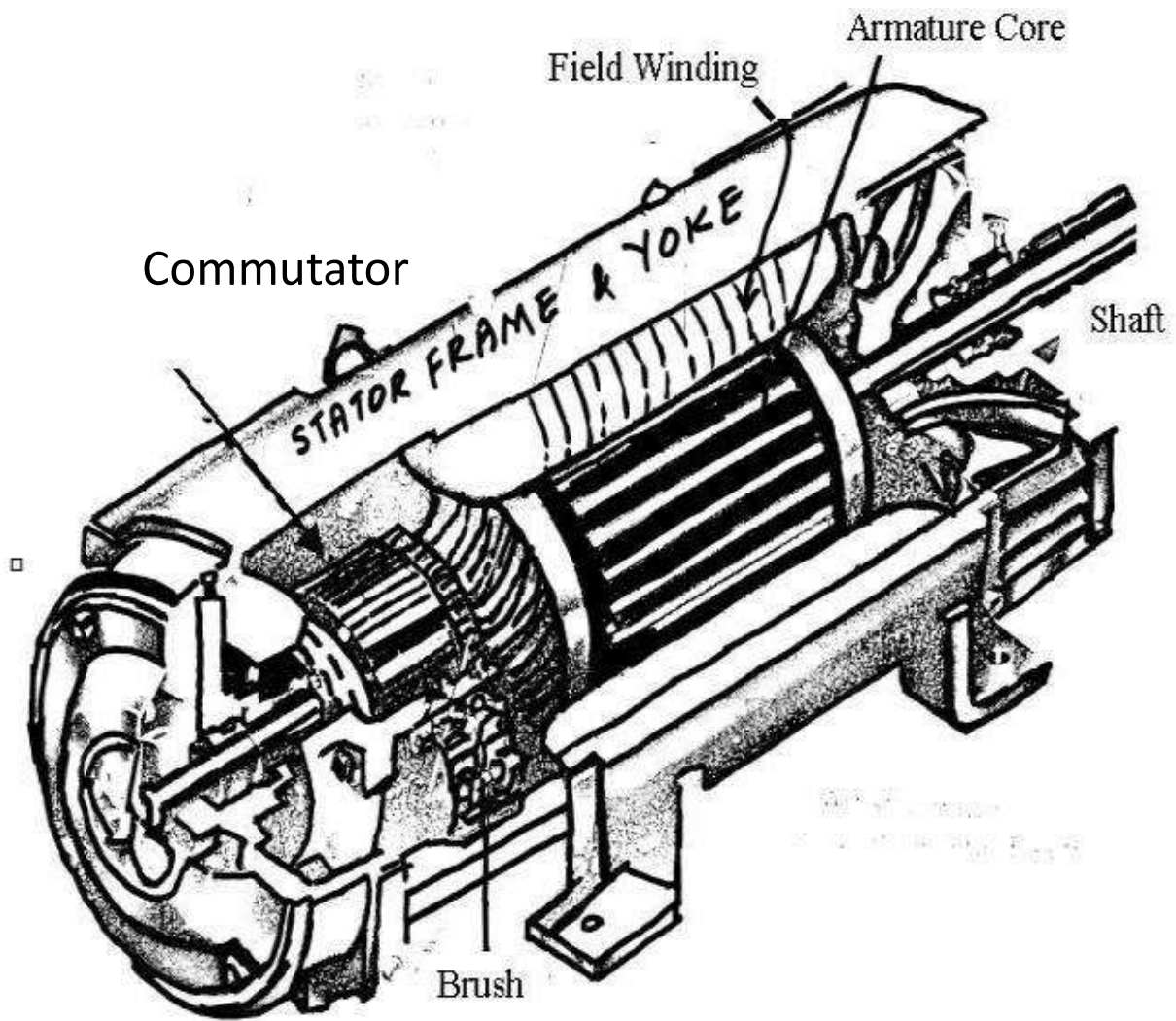
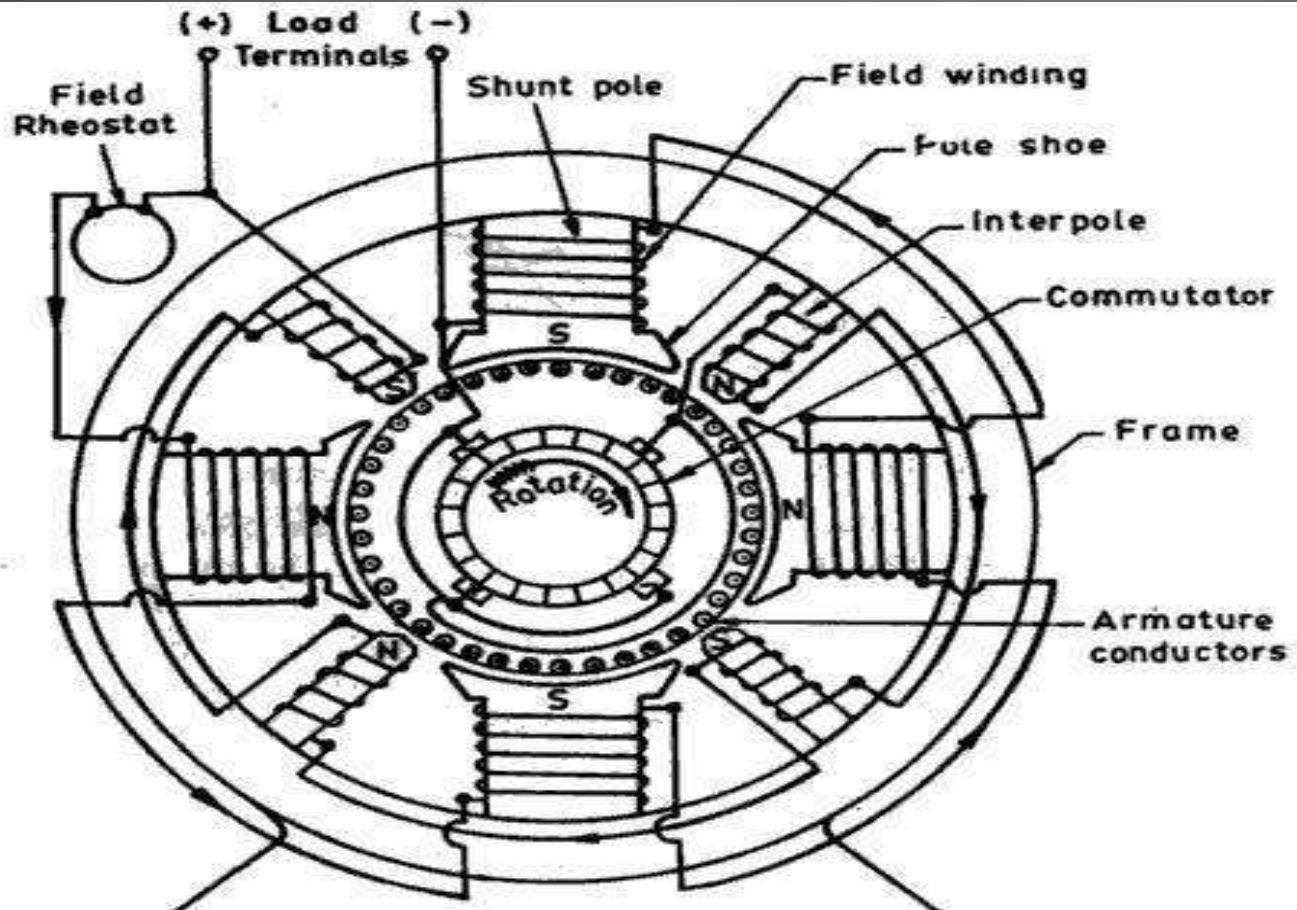

Fig. 1.1. Construction of a DC motor.

SECTIONAL VIEW OF A DC MACHINE



Construction of DC Generator

- Field system
- Armature core
- Armature winding
- Commutator

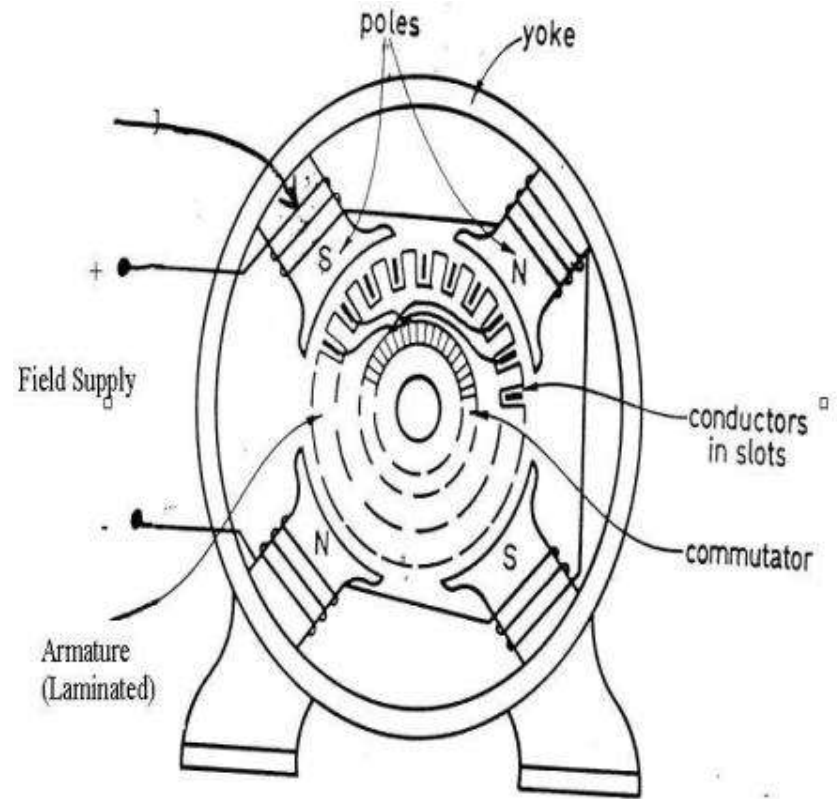

Field winding

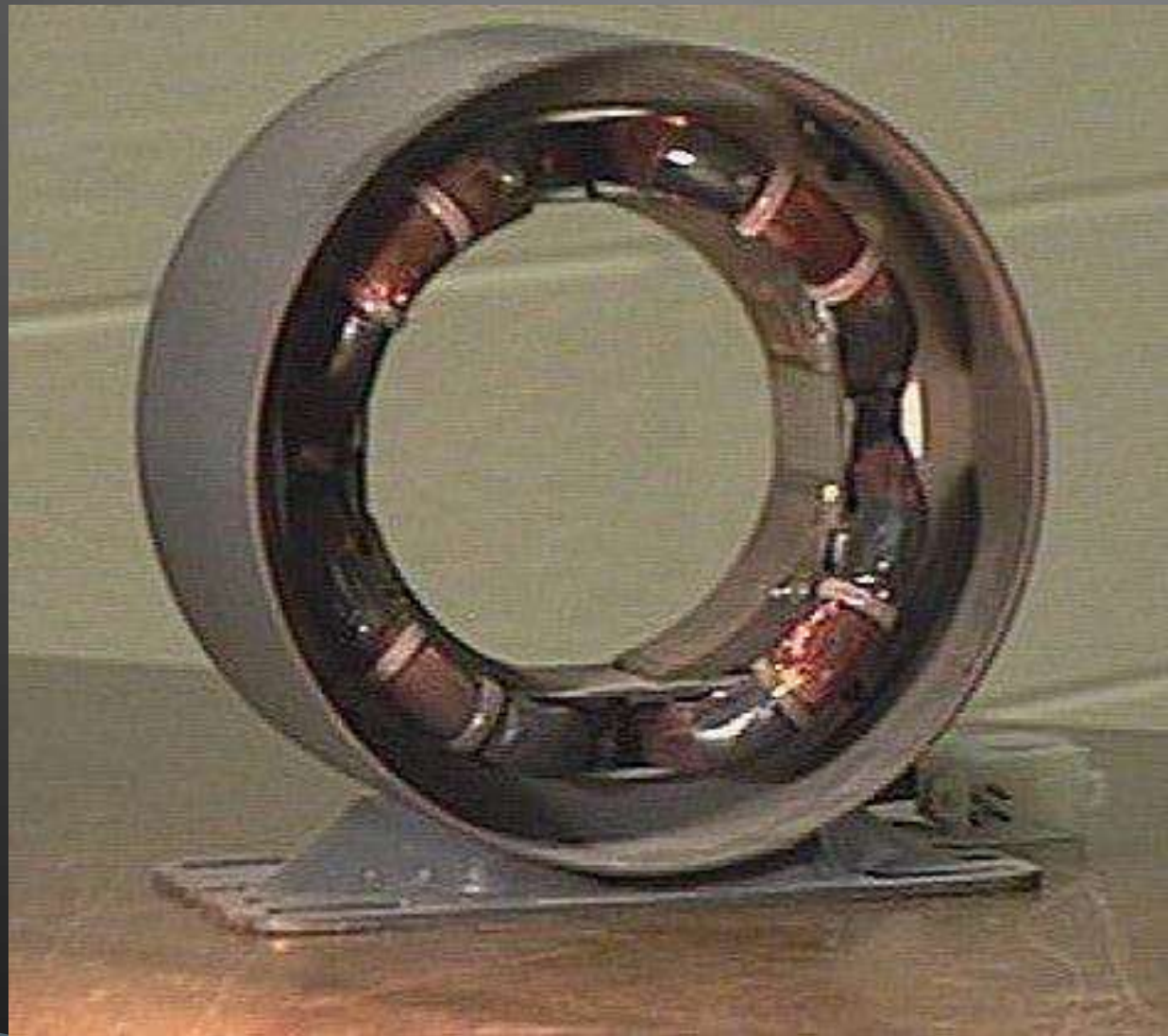

Rotor and rotor winding

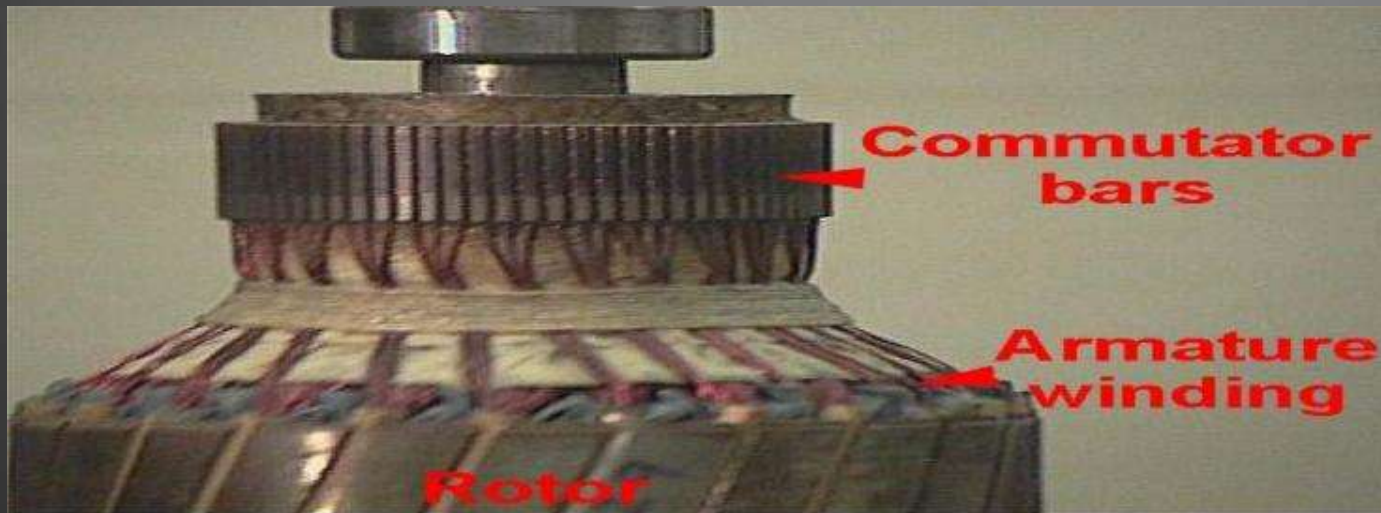

Armature winding

There are 2 types of winding

- **Lap and**
- **Wave winding**

Lap winding $A = P$

The armature windings are divided into no. of sections equal to the no of poles

Wave winding $A =$

2

It is used in low current output and high voltage.

2 brushes

Field system

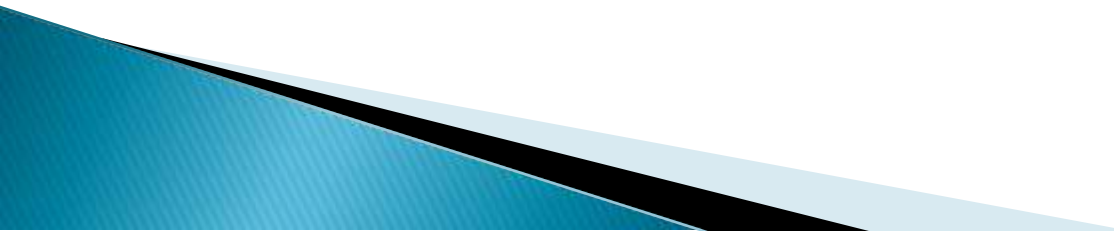
- It is for uniform magnetic field within which the armature rotates.
 - Electromagnets are preferred in comparison with permanent magnets
 - They are cheap , smaller in size , produce greater magnetic effect and
 - Field strength can be varied
- 

FIELD SYSTEM CONSISTS OF THE FOLLOWING PARTS

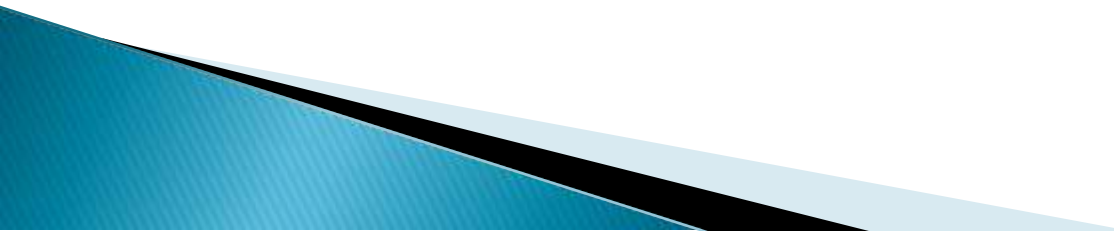
- Yoke
 - Pole cores
 - Pole shoes
 - Field coils
- 

Armature core

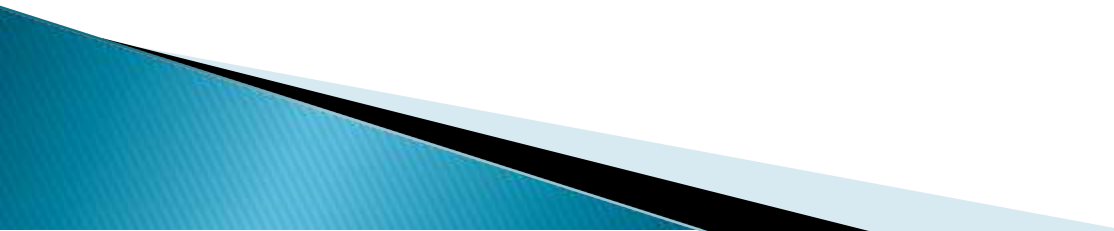
- The armature core is cylindrical High permeability silicon steel stampings
 - Impregnated
 - Lamination is to reduce the eddy current loss
- 

Commutator

- Connect with external circuit
 - Converts ac into unidirectional current Cylindrical in shape
 - Made of wedge shaped copper segments Segments are insulated from each other
 - Each commutator segment is connected to armature conductors by means of a cu strip called riser.
 - No of segments equal to no of coils
- 

Carbon brush

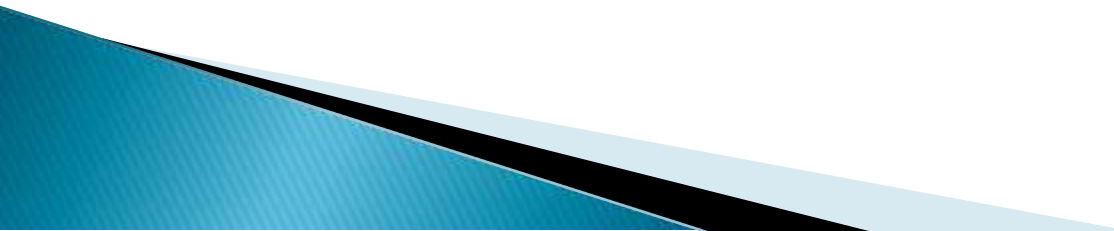
- Carbon brushes are used in DC machines because they are soft materials
 - It does not generate spikes when they contact commutator
 - To deliver the current thro armature
 - Carbon is used for brushes because it has negative temperature coefficient of resistance
- 

Brush rock and holder

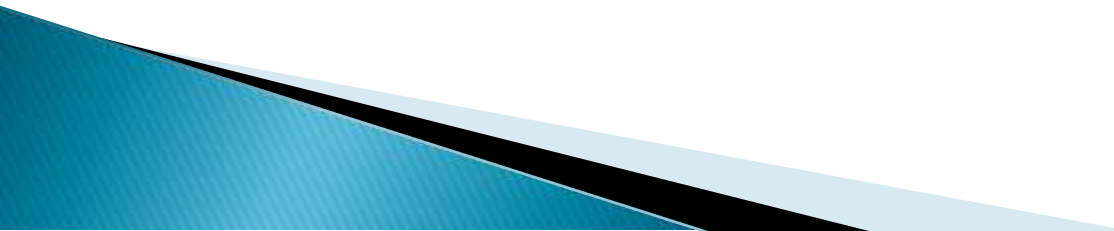

Carbon brush

- Brush leads (pig tails)
 - Brush rocker (brush gear)
 - Front end cover
 - Rear end cover Cooling
 - fan Bearing
 - Terminal box
- 

EMF Equation

Let,

Φ = flux per pole in weber

Z = Total number of conductor P = Number of poles

A = Number of parallel paths

N = armature speed in rpm

E_g = emf generated in any one of the parallel paths

EMF equation

Flux cut by 1 conductor in 1 revolution = $P * \phi$

Flux cut by 1 conductor in 60 sec = $P \phi N / 60$

Avg emf generated in 1 conductor = $P\phi N / 60$

Number of conductors in each parallel path = Z / A

$$E_g = P\phi NZ / 60A$$

Types of DC Generator

- Separately excited DC generator.
- Self excited DC generator

Types of DC Machines

Both the armature and field circuits carry direct current in the case of a DC machine.

Types:

Self-excited DC machine: when a machine supplies its own excitation of the field windings. In this machine, residual magnetism must be present in the ferromagnetic circuit of the machine in order to start the self-excitation process.

Separately-excited DC machine: The field windings may be separately excited from an external DC source.

Shunt Machine: armature and field circuits are connected in parallel. Shunt generator can be separately-excited or self-excited.

Series Machine: armature and field circuits are connected in series.

Separately-Excited and Self-Excited DC Generators

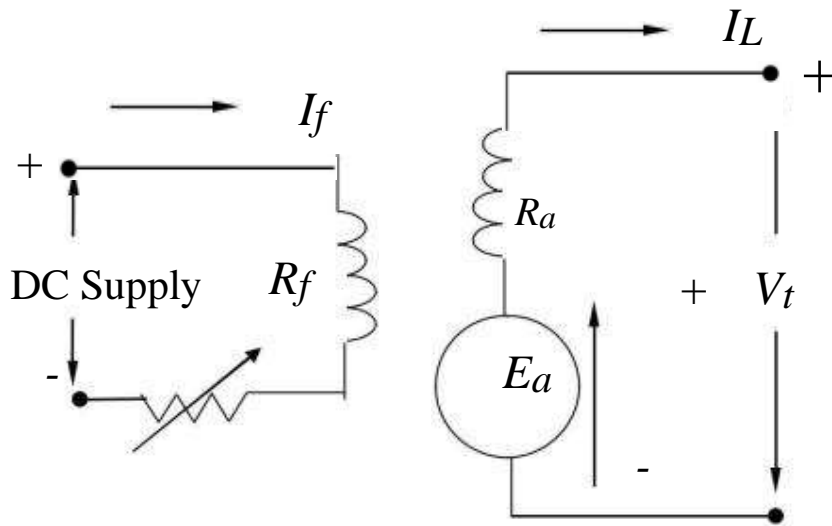

Separately-Excited

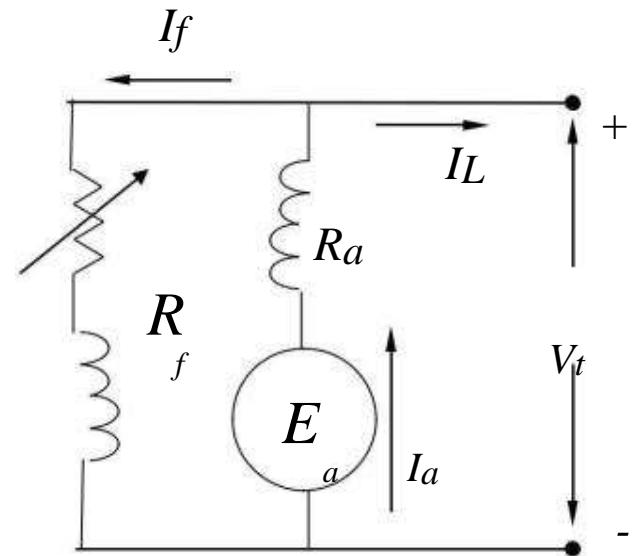

Self-Excited

Further classification of DC Generator

- Series wound generator
 - Shunt wound generator
 - Compound wound generator
 - Short shunt & Long shunt
 - Cumulatively compound
 - Differentially compound
- 

Applications

Shunt Generators:

- a. in electro plating
- b. for battery recharging
- c. as exciters for AC generators.

Series Generators :

- A. As boosters
 - B. As lighting arc lamps
- 

DC Motors

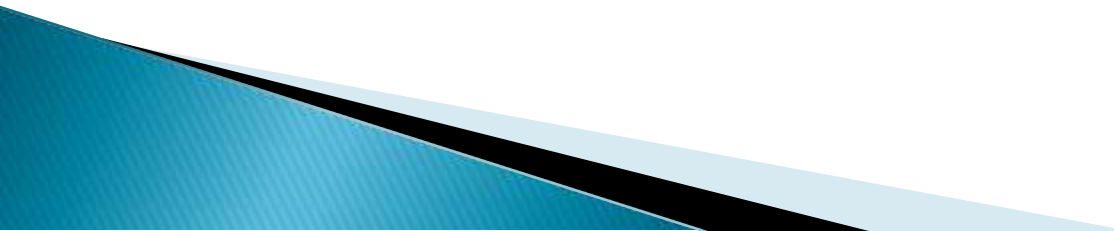
- ▶ Converts Electrical energy into Mechanical energy
 - ▶ Construction : Same for Generator and motor
 - ▶ Working principle : Whenever a current carrying conductor is placed in the magnetic field , a force is set up on the conductor.
- 

Working principle of DC motor

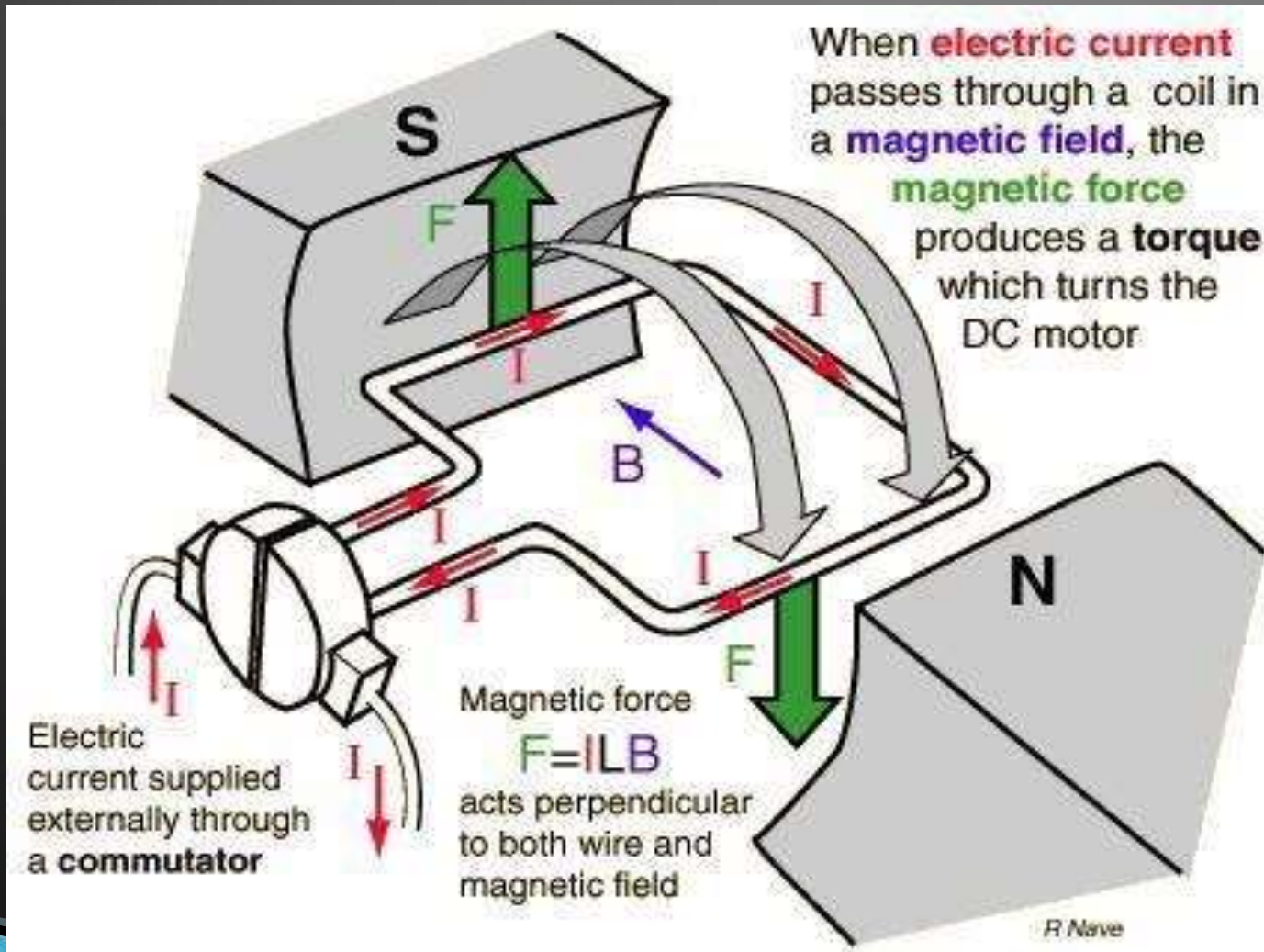

Working principle of DC motor

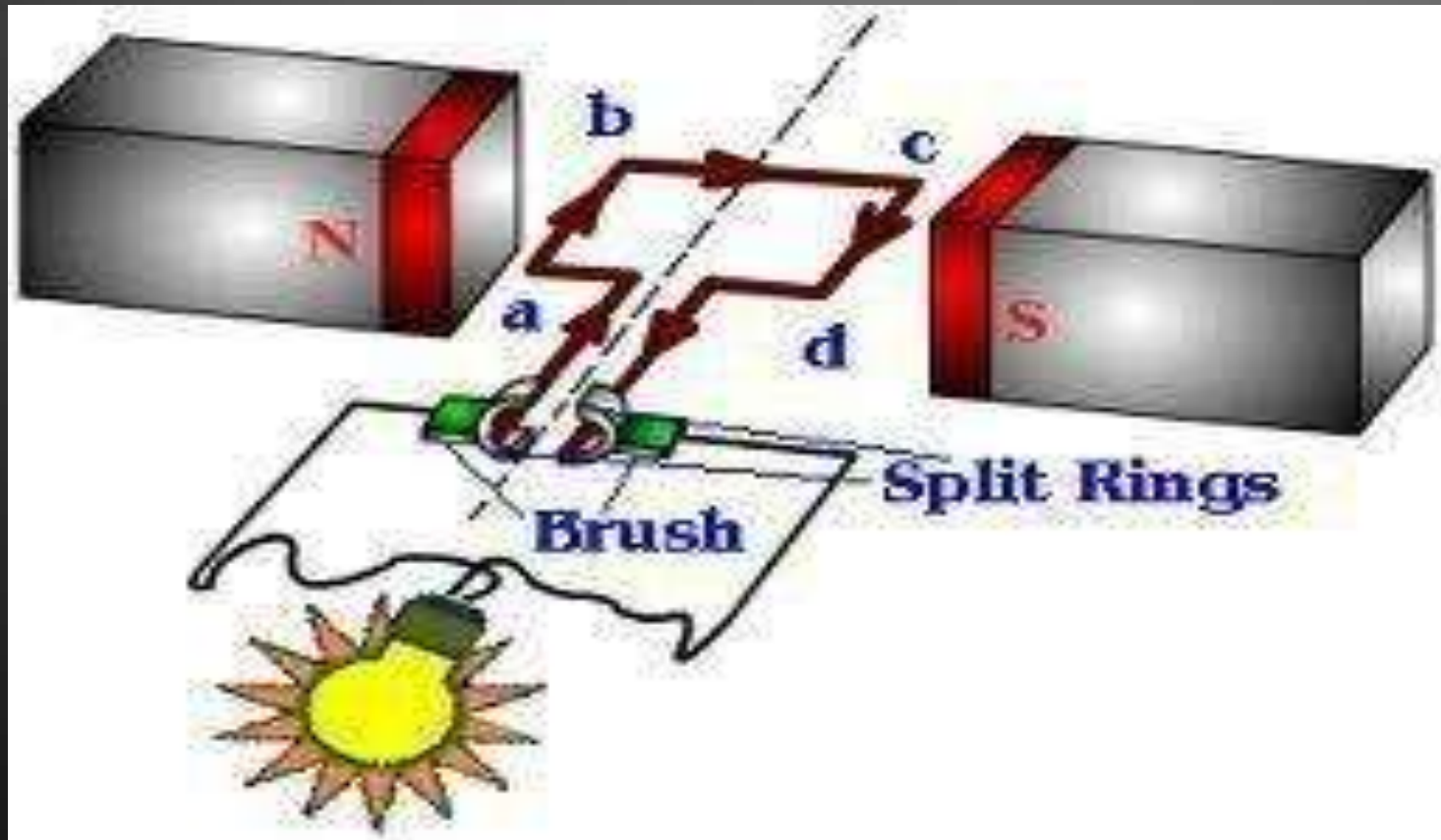

Force in DC motor

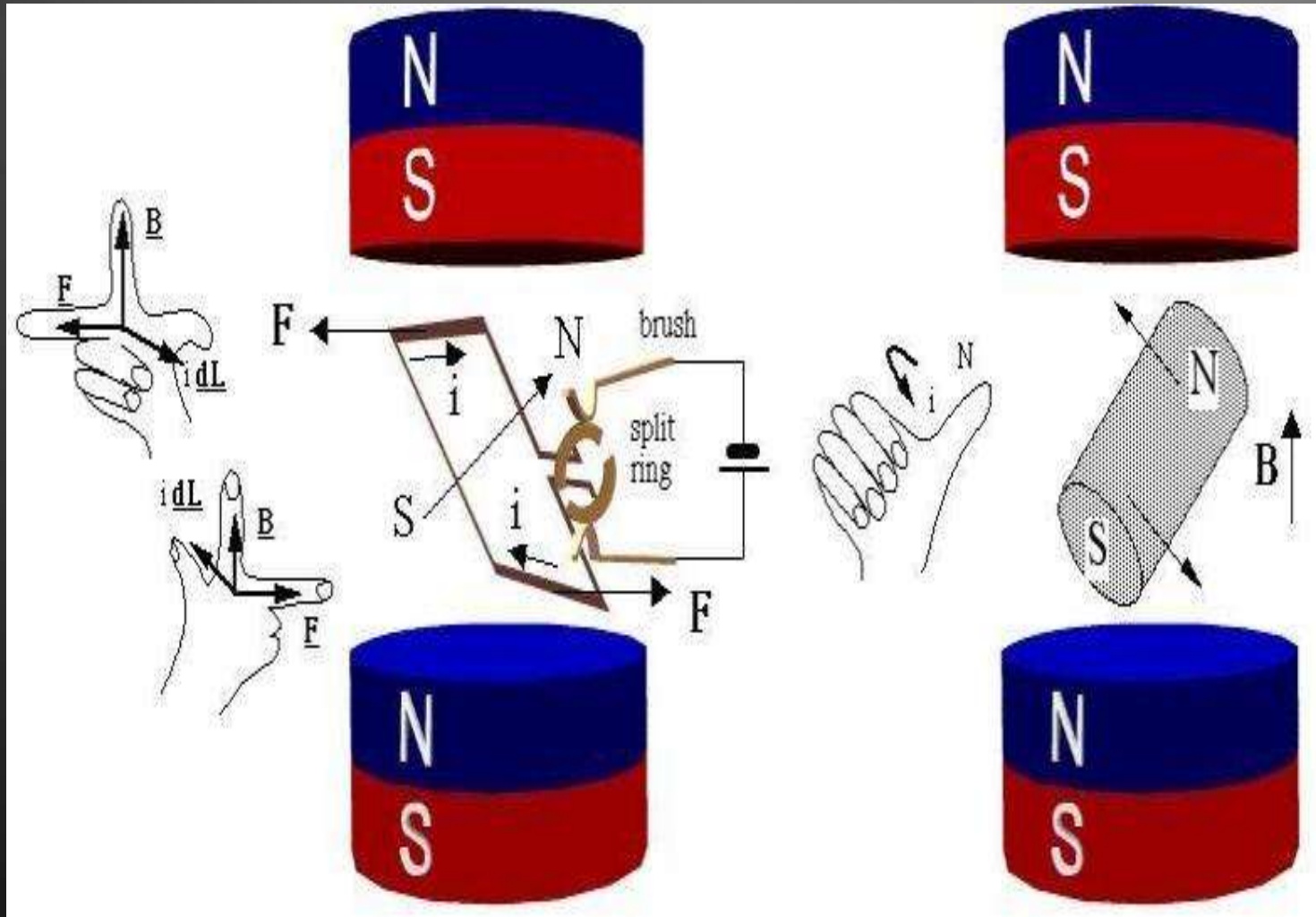

Fleming's left hand rule

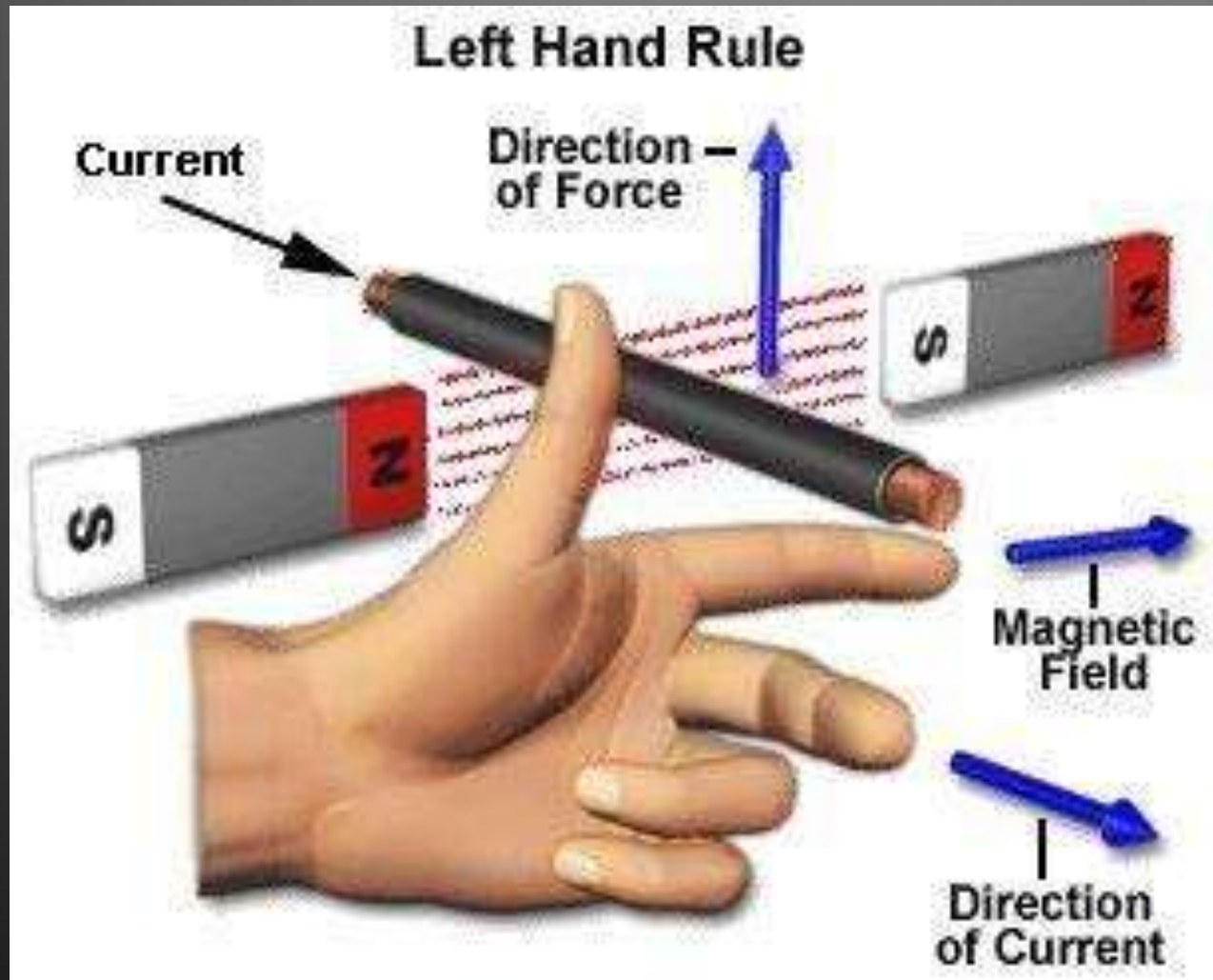

Fleming's left hand rule

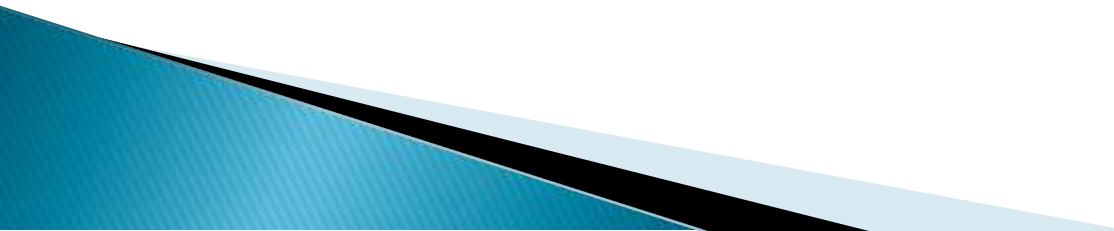
- Used to determine the direction of force acting on a current carrying conductor placed in a magnetic field .
 - The middle finger , the fore finger and thumb of the left hand are kept at right angles to one another .
 - The middle finger represent the direction of current
 - The fore finger represent the direction of magnetic field
 - The thumb will indicate the direction of force acting on the conductor .This rule is used in motors.
- 

Back emf

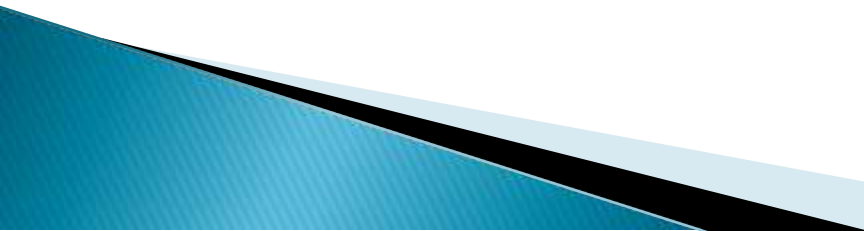
- The induced emf in the rotating armature conductors always acts in the opposite direction of the supply voltage .
 - According to the Lenz's law, the direction of the induced emf is always so as to oppose the cause producing it .
 - In a DC motor , the supply voltage is the cause and hence this induced emf opposes the supply voltage.
- 

Lenz's Law

The direction of induced emf is given by Lenz's law .

According to this law, the induced emf will be acting in such a way so as to oppose the very cause of production of it .

$$e = -N (d\Phi/dt) \text{ volts}$$

Classification of DC motors

DC motors are mainly classified into three types as listed below:

- Shunt motor
 - Differential compound
 - Cumulative compound
- 

Torque

The turning or twisting force about an axis is called torque .

$$P = T * 2 \pi N / 60$$

$$E_b I_a = T_a * 2 \pi N / 60$$

$$T \propto \phi I_a \quad T_a \propto I_a^2$$

Characteristic of DC motors

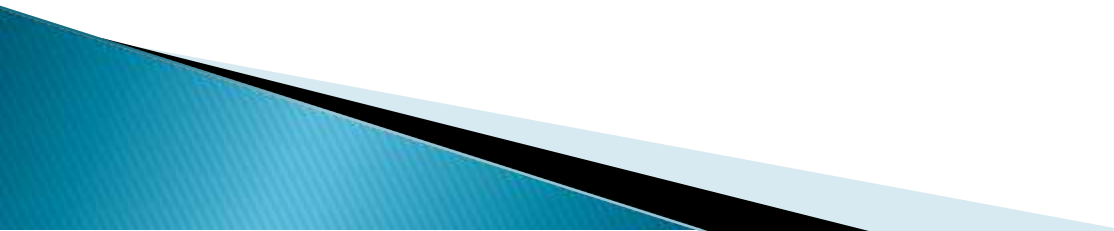
- T/ I_a characteristic
 - N/ I_a characteristic
 - N/T characteristic
- 

Starters for DC motors

Needed to limit the starting current .

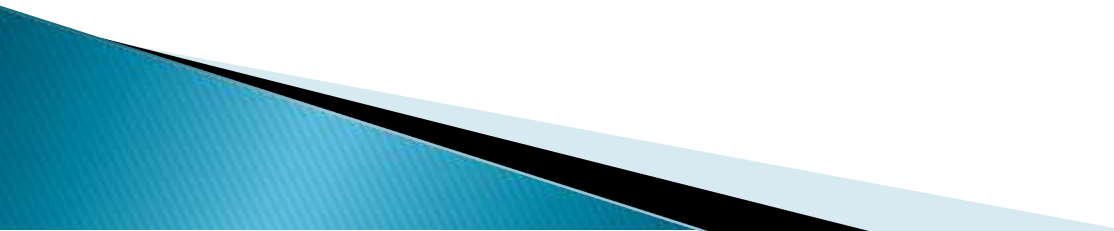
1. Two point starter
 2. Three point starter
 3. Four point starter
- 

Testing of DC machines

To determine the efficiency of a DC motor, the output and input should be known.

There are two methods.

The load test or The direct method The indirect method

- Direct method: In this method, the efficiency is determined by knowing the input and output power of the motor.
- Indirect method: Swinburne's test is an indirect method of testing DC shunt machines to predetermine the efficiency, as a motor and as a Generator. In this method, efficiency is calculated by determining the losses.

Applications:

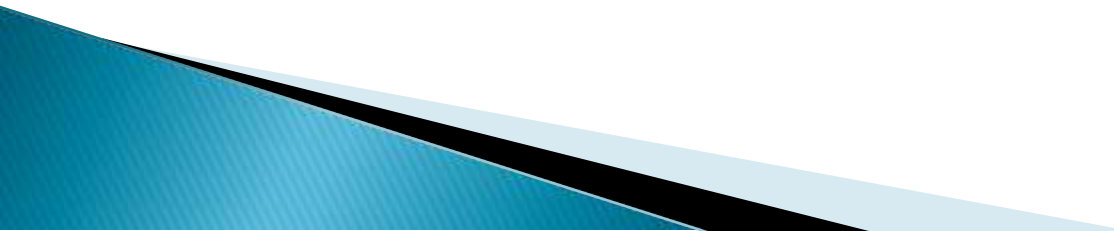
- Blowers and fans
 - Centrifugal and reciprocating pumps
 - Lathe machines
 - Machine tools
 - Milling machines
 - Drilling machines
- 

Applications:

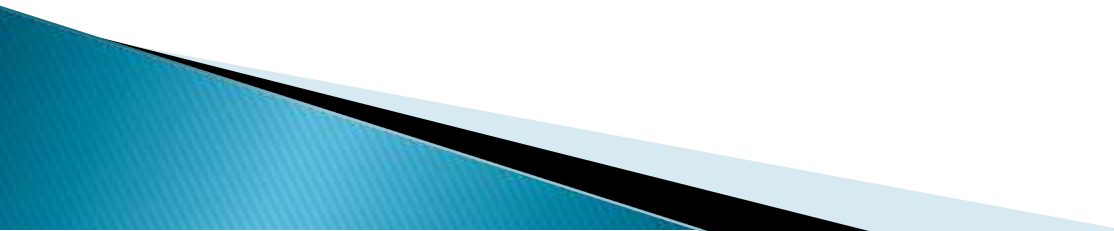
- Cranes
 - Hoists , Elevators
Trolleys Conveyors
 - Electric
locomotives
- 

Application:

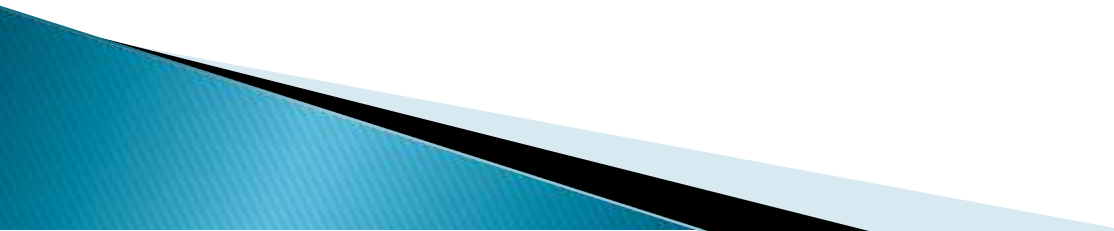
- Rolling mills
 - Punches
 - Shears
 - Heavy planers
 - Elevators
- 

Transformers



UNIT-III

ALTERNATING QUANTITIES AND AC MACHINES

Introduction

- A transformer is a device that changes ac electric power at one voltage level to ac electric power at another voltage level through the action of a magnetic field.
 - There are two or more stationary electric circuits that are coupled magnetically.
 - It involves interchange of electric energy between two or more electric systems
 - Transformers provide much needed capability of changing the voltage and current levels easily.
 - They are used to step-up generator voltage to an appropriate voltage level for power transfer.
 - Stepping down the transmission voltage at various levels for distribution and power utilization.
- 

Transformer Classification

- In terms of number of windings
 - Conventional transformer: two windings
 - Autotransformer: one winding
 - Others: more than two windings
- In terms of number of phases
 - Single-phase transformer
 - Three-phase transformer
- Depending on the voltage level at which the winding is operated
 - Step-up transformer: primary winding is a low voltage (LV) winding
 - Step-down transformer : primary winding is a high voltage (HV) winding

Primary and Secondary Windings

A two-winding transformer consists of two windings interlinked by a mutual magnetic field.

–Primary winding – energized by connecting it to an input source

–Secondary winding – winding to which an electrical load is connected and from which output energy is drawn.

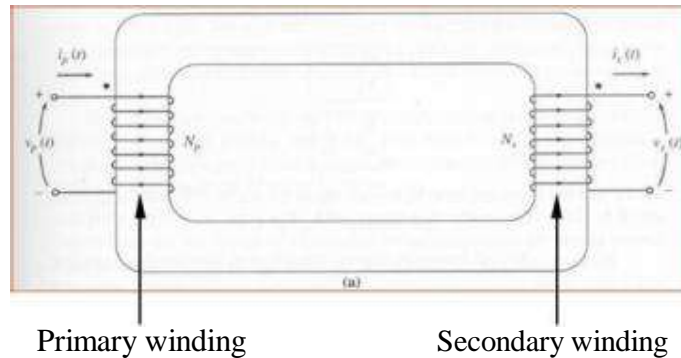

Ideal Transformers

An ideal transformer is a lossless device with an input winding and an output winding. It has the following properties:

- No iron and copper losses
- No leakage fluxes
- A core of infinite magnetic permeability and of infinite electrical resistivity
- Flux is confined to the core and winding resistances are negligible

Ideal Transformers

An ideal transformer is a lossless device with an input winding and an output winding.

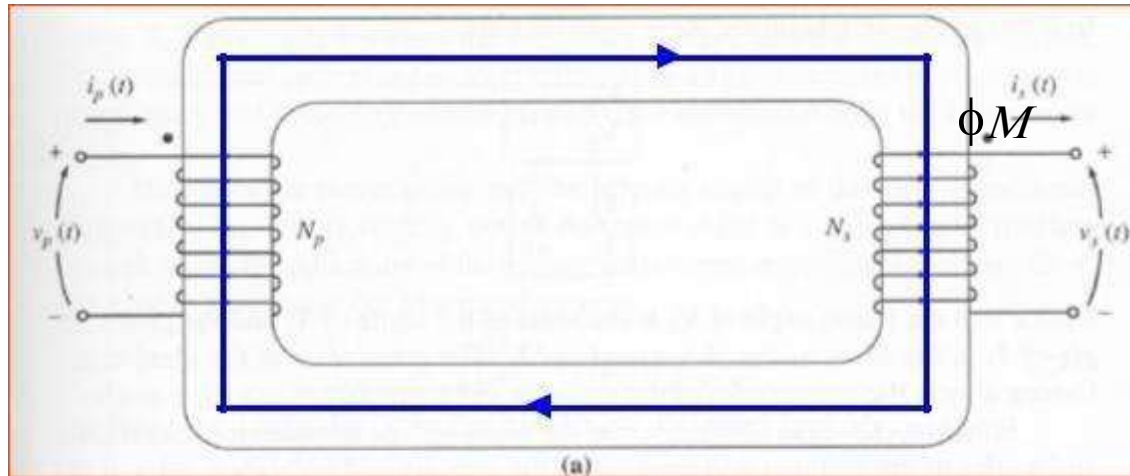

The relationships between the input voltage and the output voltage, and between the input current and the output current, are given by the

Ideal Transformers

In rms quantities



$$\frac{V_p}{V_s} = \frac{I_s}{I_p} = a$$

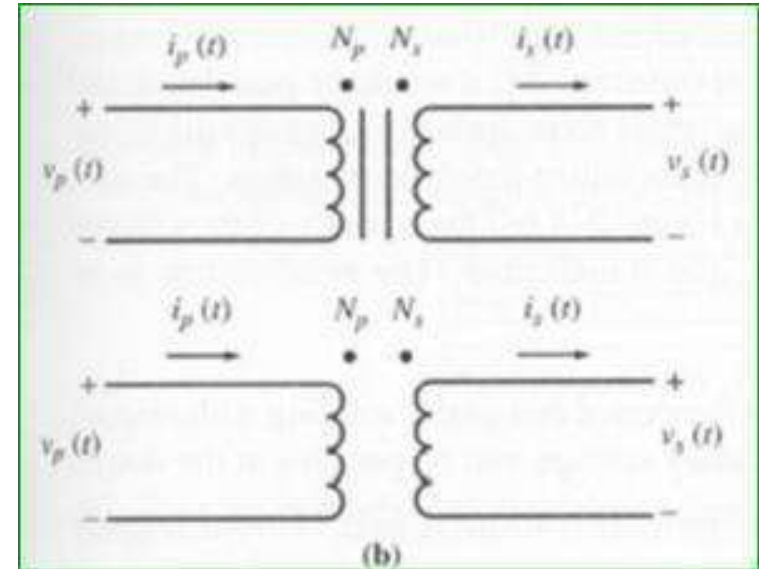

N_p : Number of turns on the primary winding

N_s : Number of turns on the secondary winding

$v_p(t)$: voltage applied to the primary side

$v_s(t)$: voltage at the secondary side

a : turns ratio
 $i_p(t)$: current flowing into the primary side

$i_s(t)$: current flowing into the secondary side

Derivation of the Relationship

$$v_p(t) = \frac{d\lambda_p(t)}{dt} N_p \frac{d\phi_M(t)}{dt} \dots\dots\dots (1)$$

$$v_s(t) = \frac{d\lambda_s(t)}{dt} = N_s \frac{d\phi_M(t)}{dt} \dots\dots\dots (2)$$

Dividing (1) by (2)

$$\frac{v_p(t)}{v_s(t)} = \frac{N_p}{N_s} \dots\dots\dots (3)$$

$$v_p(t) = \frac{N_p}{N_s} v_s(t) = a v_s(t)$$

From Ampere's law

$$N_p i_p(t) = N_s i_s(t)$$

$$\frac{i_p(t)}{i_s(t)} = \frac{N_s}{N_p} \dots\dots\dots (4)$$

$$i_p(t) = \frac{N_s}{N_p} i_s(t) = a i_s(t)$$

Equating (3) and (4)

$$\frac{v_p(t)}{v_s(t)} = \frac{i_s(t)}{i_p(t)} \frac{N_p}{N_s} \dots\dots\dots (5)$$

$$v_p(t) = i_p(t) = N_s = a$$

Example 1

A 100-kVA, 2400/240-V, 60-Hz step-down transformer (ideal) is used between a transmission line and a distribution system.

a) Determine turns ratio.

b) What secondary load impedance will cause the transformer to be fully loaded, and what is the corresponding primary current?

c) Find the load impedance referred to the primary.

Solution to Example 1

a) Turns ratio, $a = 2400 / 240 = 10$

b) $I_s = 100,000 / 240 = 416.67 \text{ A}$

$$I_p = I_s / a = 416.67 / 10 = 41.67 \text{ A}$$

Magnitude of the load impedance

$$= V_s / I_s = 240 / 416.7 = 0.576 \text{ ohm}$$

c) Load impedance referred to the primary

$$= a^2 * 0.576 = 57.6 \text{ ohm}$$

Theory of Operation of Single-Phase Real Transformers

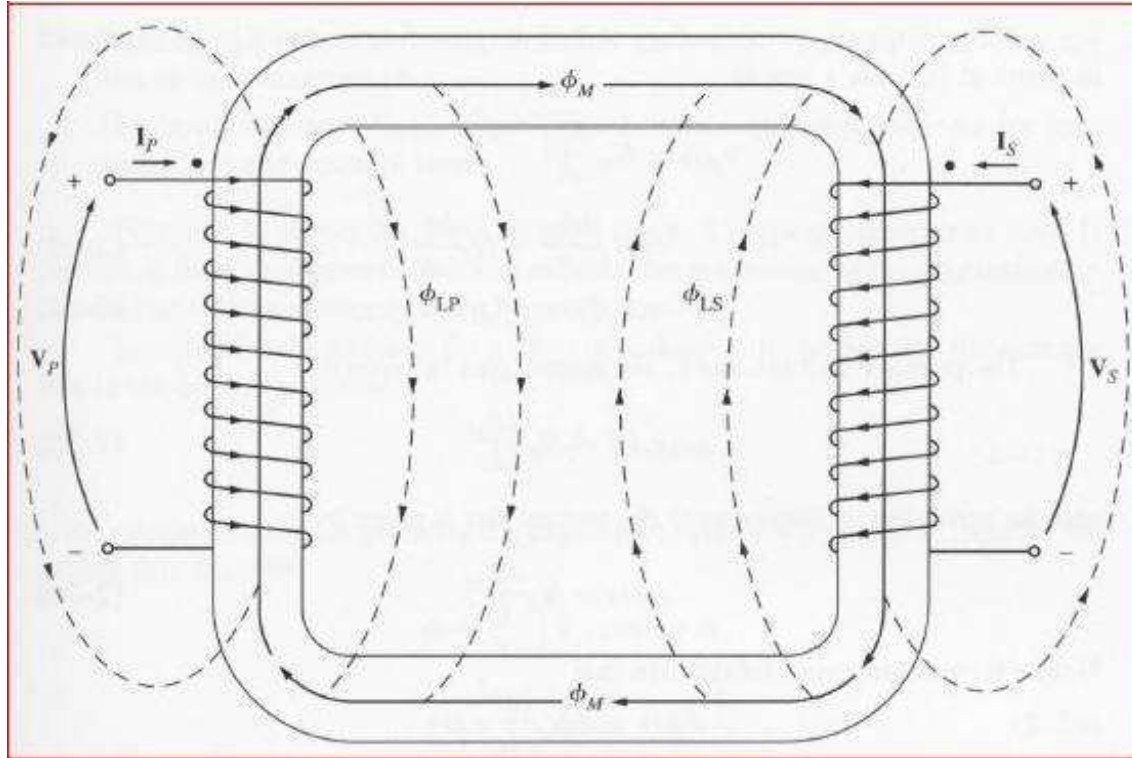

Leakage flux: flux that goes through one of the transformer windings but not the other one

Mutual flux: flux that remains in the core and links both windings

Theory of Operation of Single-Phase Real Transformers

$$\phi_P = \phi_M + \phi_{LP}$$

$$\phi_S = \phi_M + \phi_{LS}$$

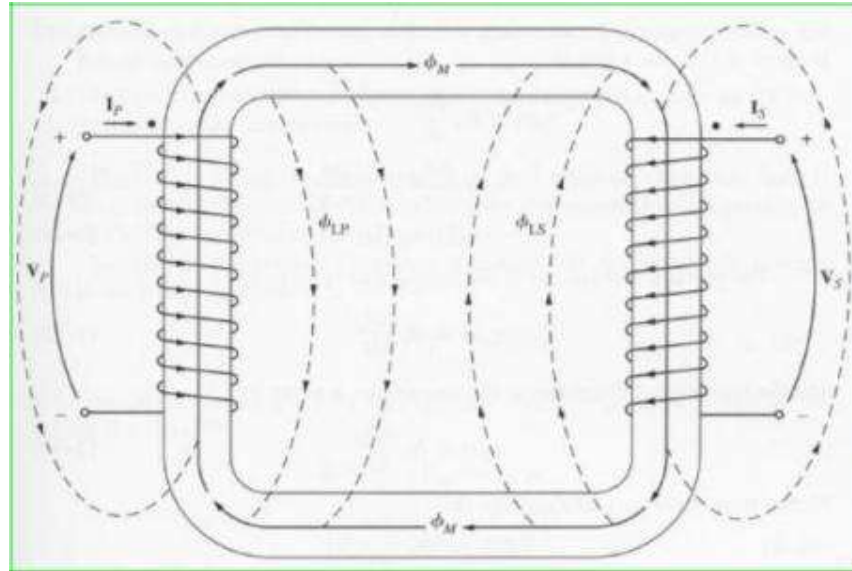

ϕ_p : total average primary flux

ϕ_M : flux linking both primary and secondary windings

ϕ_{LP} : primary leakage flux

ϕ_S : total average secondary flux

ϕ_{LS} : secondary leakage flux

Magnetization Current

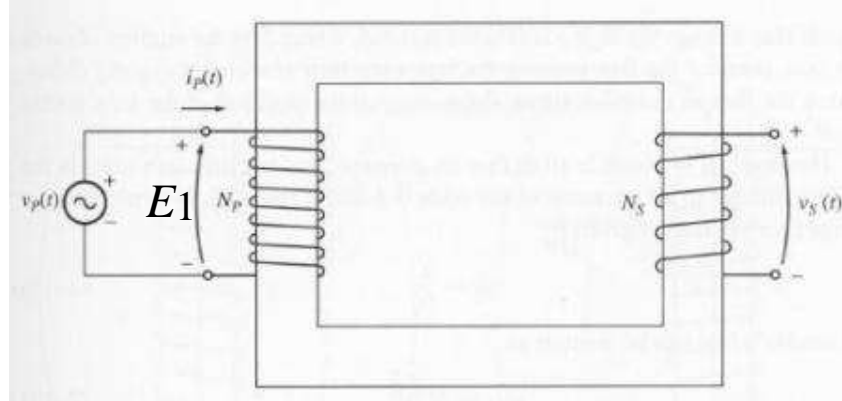

When an ac power source is connected to a transformer, a current flows in its primary circuit, even when the secondary circuit is open circuited. This current is the current required to produce flux in the ferromagnetic core and is called *excitation current*. It consists of two components:

1. The *magnetization current* I_m , which is the current required to produce the flux in the transformer core
2. The *core-loss current* I_{h+e} , which is the current required to make up for hysteresis and eddy current losses

The Magnetization Current in a Real Transformer

When an ac power source is connected to the primary of a transformer, a current flows in its primary circuit, even when there is no current in the secondary. The transformer is said to be on no-load. If the secondary current is zero, the primary current should be zero too. However, when the transformer is on no-load, excitation current flows in the primary because of the core losses and the finite permeability of the core.

Excitation current, I_o

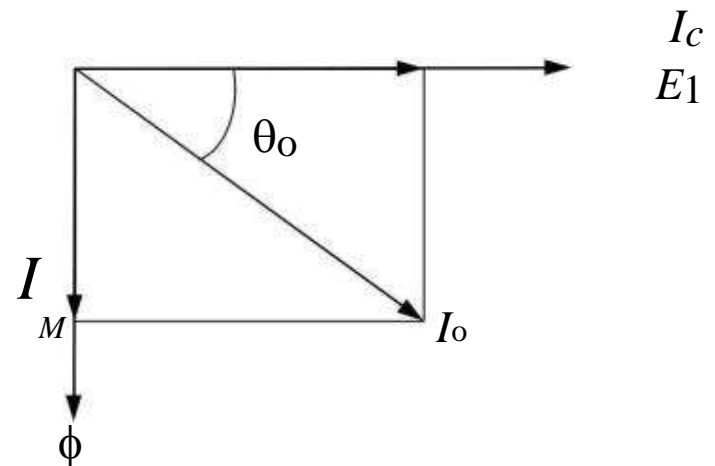
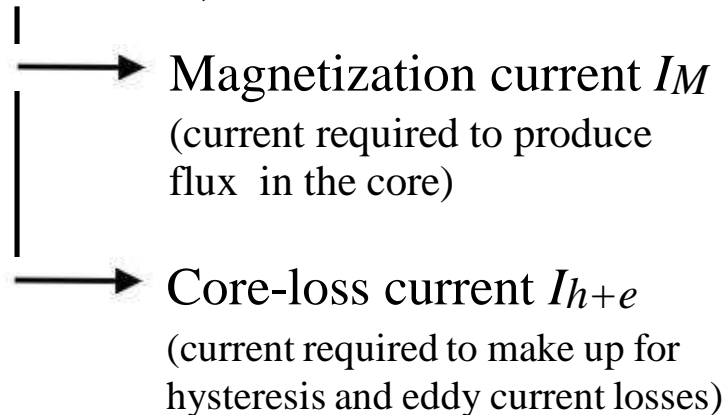

I_M is proportional to the flux ϕ
 $I_c = I_{h+e} = \text{Core loss}/E_1$

Losses of a Transformer

The losses that occur in transformers have to be accounted for in any accurate model of transformer behavior.

1. *Copper (I^2R) losses*. Copper losses are the resistive heating losses in the primary and secondary windings of the transformer. They are proportional to the square of the current in the windings.

2. *Eddy current losses*. Eddy current losses are resistive heating losses in the core of the transformer. They are proportional to the square of the voltage applied to the transformer.

3. *Hysteresis losses*. Hysteresis losses are associated with the rearrangement of the magnetic domains in the core during each half-cycle. They are a complex, nonlinear function of the voltage applied to the transformer.

4. *Leakage flux*. The fluxes which escape the core and pass through only one of the transformer windings are leakage fluxes. These escaped fluxes produce a self-inductance in the primary and secondary coils, and the effects of this inductance must be accounted for.

The Exact Equivalent Circuit of a Transformer

Modeling the copper losses: resistive losses in the primary and secondary windings of the core, represented in the equivalent circuit by R_P and R_S .

Modeling the leakage fluxes: primary leakage flux is proportional to the primary current I_P and secondary leakage flux is proportional to the secondary current I_S , represented in the equivalent circuit by $X_P (= \phi_{LP}/I_P)$ and $X_S (= \phi_{LS}/I_S)$.

Modeling the core excitation: I_m is proportional to the voltage applied to the core and lags the applied voltage by 90° . It is modeled by X_M .

Modeling the core loss current: I_{h+e} is proportional to the voltage applied to the core and in phase with the applied voltage. It is modeled by R_C .

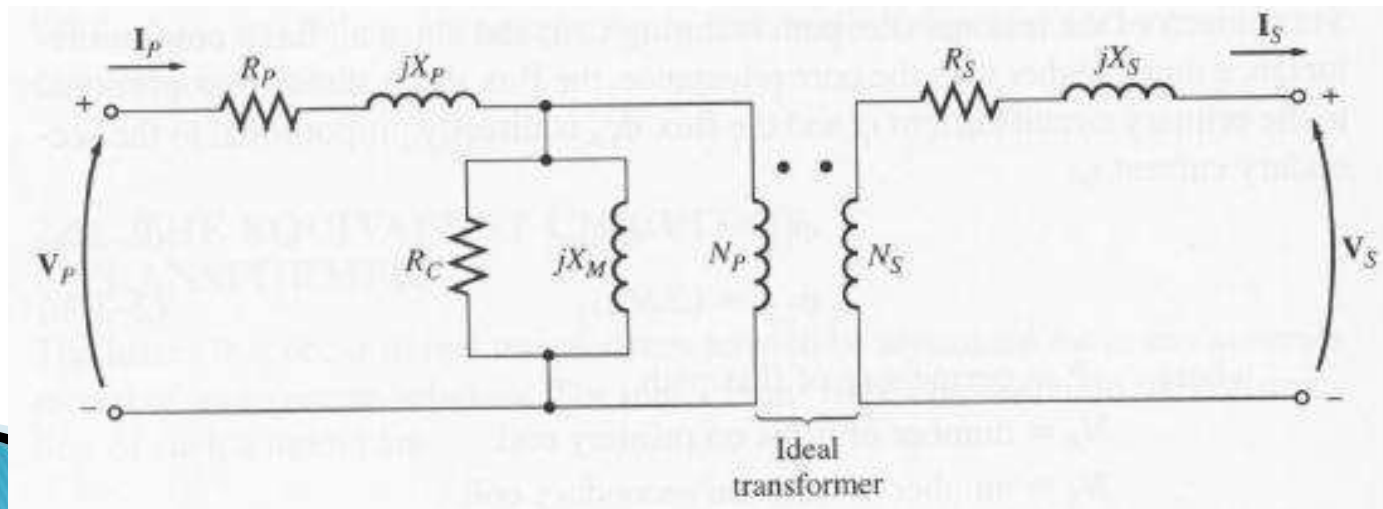

The Exact Equivalent Circuit of a Transformer

Although the previous equivalent circuit is an accurate model of a transformer, it is not a very useful one. To analyze practical circuits containing transformers, it is normally necessary to convert the entire circuit to an equivalent circuit at a single voltage level. Therefore, the equivalent circuit must be referred either to its primary side or to its secondary side in problem solutions.

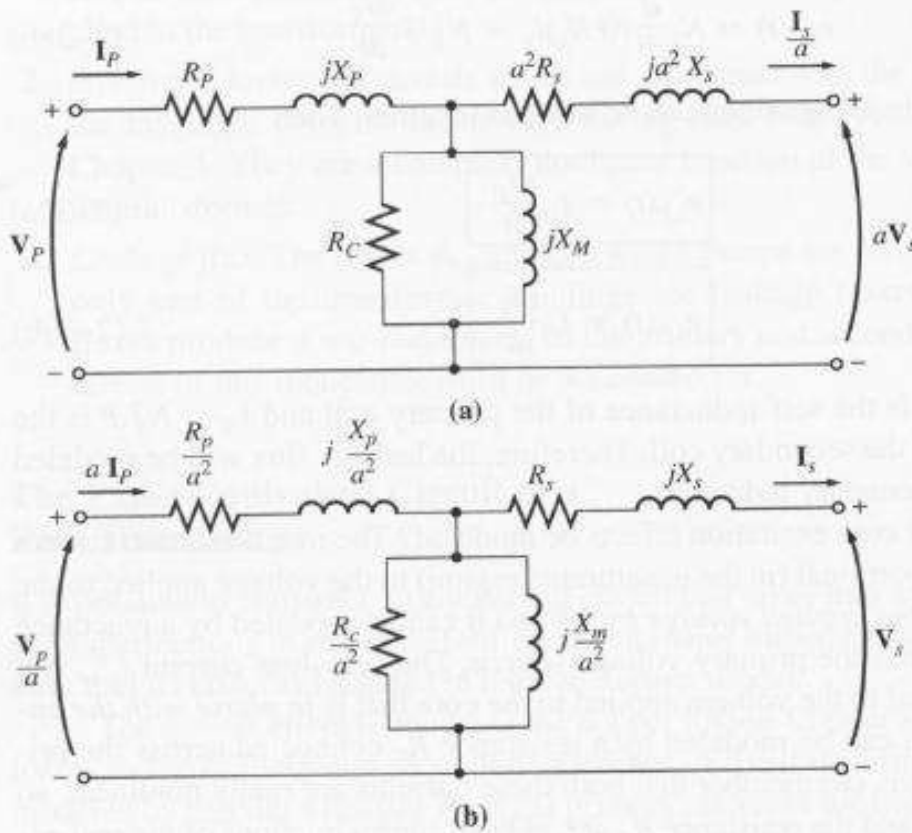

Figure (a) is the equivalent circuit of the transformer referred to its primary side.

Figure (b) is the equivalent circuit referred to its secondary side.

Approximate Equivalent Circuits of a Transformer

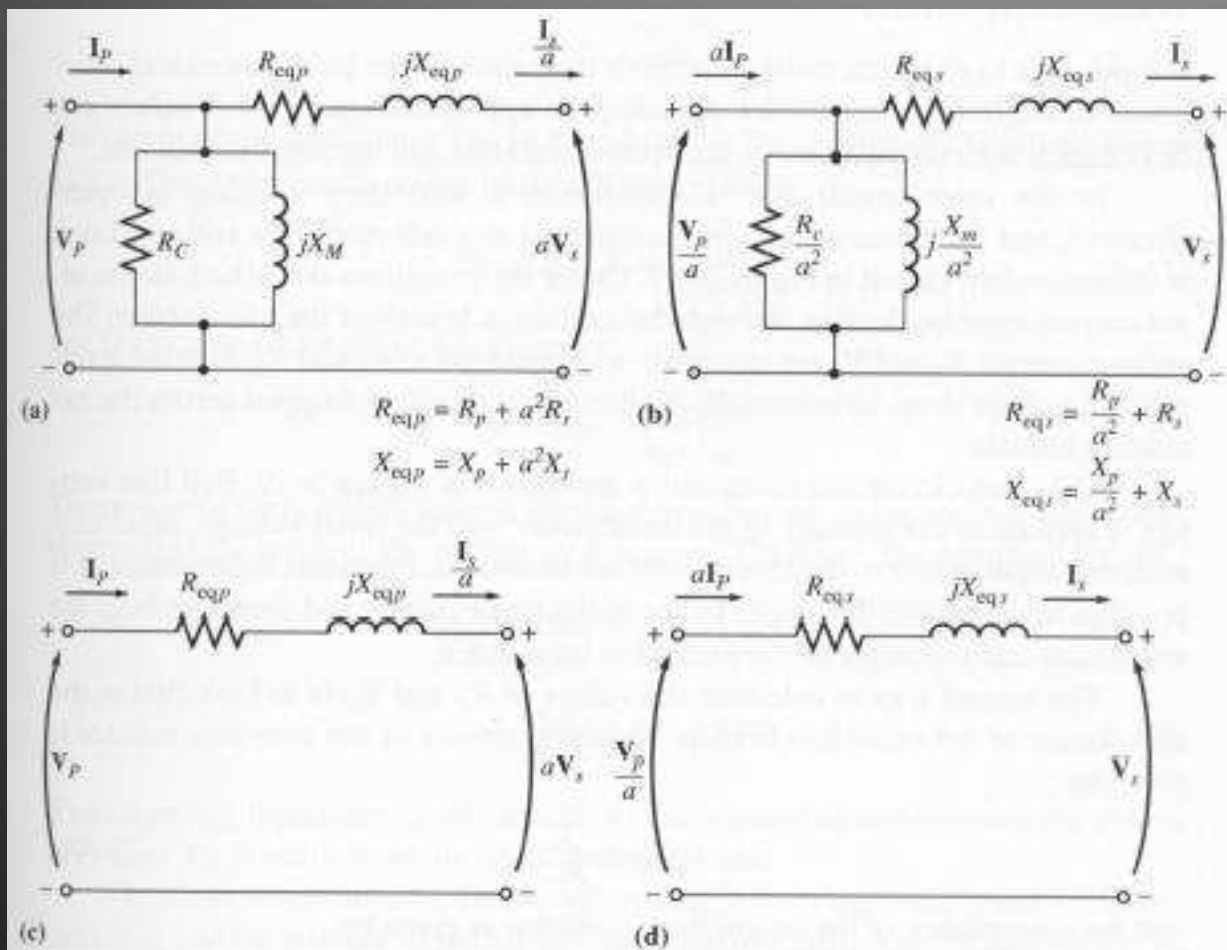

FIGURE 2-18

Approximate transformer models. (a) Referred to the primary side; (b) referred to the secondary side; (c) with no excitation branch, referred to the primary side; (d) with no excitation branch, referred to the secondary side.

Determining the Values of Components in the Transformer Model

It is possible to experimentally determine the parameters of the approximate equivalent circuit. An adequate approximation of these values can be obtained with only two tests....

- *open-circuit test*
- *short-circuit test*

Circuit Parameters: Open-Circuit Test

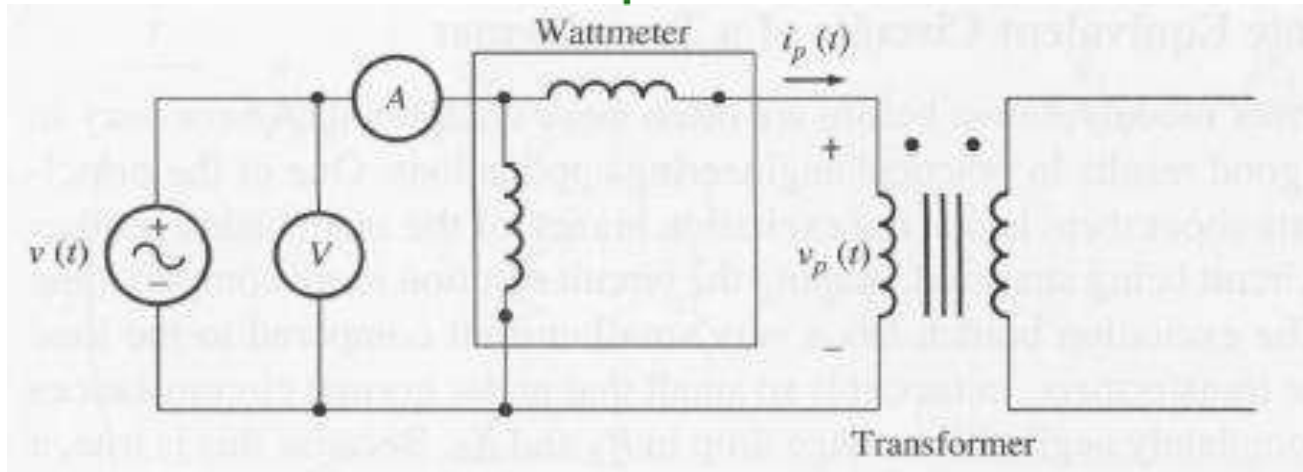

- Transformer's secondary winding is open-circuited
- Primary winding is connected to a full-rated line voltage. All the input current must be flowing through the excitation branch of the transformer.
- The series elements R_p and X_p are too small in comparison to R_C and X_M to cause a significant voltage drop, so essentially all the input voltage is dropped across the excitation branch.
- Input voltage, input current, and input power to the transformer are measured.

Circuit Parameters: Short-Circuit Test

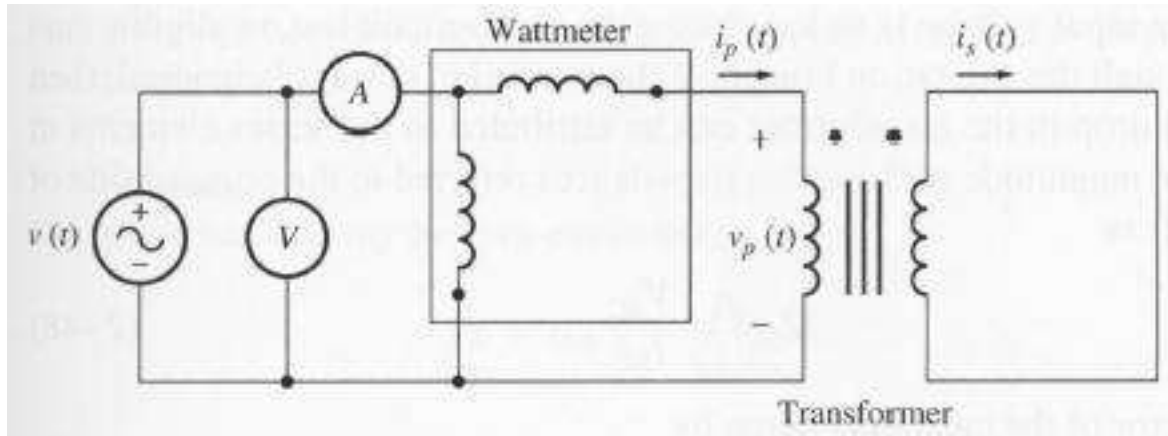

- Transformer's secondary winding is short-circuited
- Primary winding is connected to a fairly low-voltage source.
- The input voltage is adjusted until the current in the short-circuited windings is equal to its rated value.
- Input voltage, input current, and input power to the transformer are measured.
- Excitation current is negligible, since the input voltage is very low. Thus, the voltage drop in the excitation branch can be ignored. All the voltage drop can be attributed to the series elements in the circuit.

Example 2 (Example 2-2, page 92 of your text)

The equivalent circuit impedances of a 20-kVA, 8000/240-V, 60-Hz transformer are to be determined. The open-circuit test and the short-circuit test were performed on the primary side of the transformer, and the following data were taken:

Open-circuit test (on primary)	Short-circuit test (on primary)
$V_{oc} = 8000 \text{ V}$	$V_{sc} = 489 \text{ V}$
$I_{oc} = 0.214 \text{ A}$	$I_{sc} = 2.5 \text{ A}$
$P_{oc} = 400 \text{ W}$	$P_{sc} = 240 \text{ W}$

Find the impedances of the approximate equivalent circuit referred to the primary side, and sketch the circuit.

Answer to Example 2

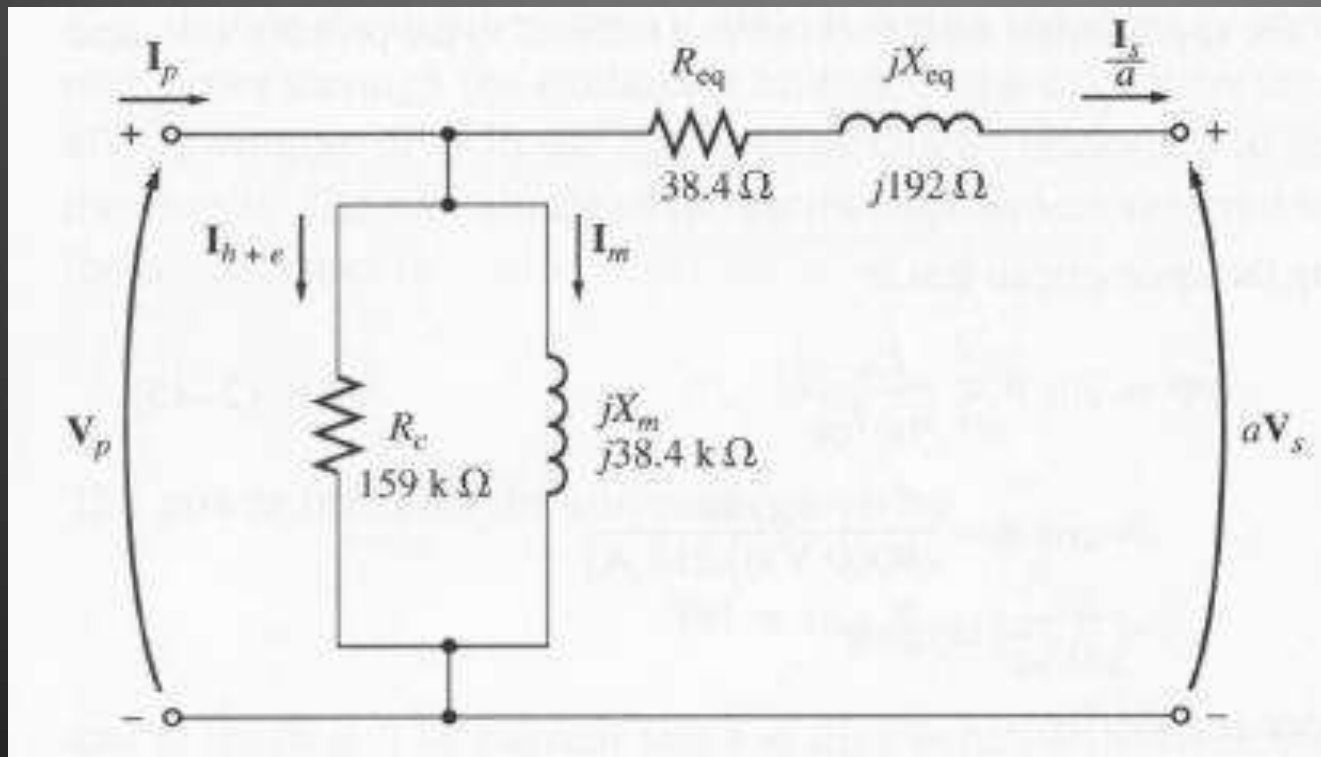

Example 3

- A single-phase, 100-kVA, 1000:100-V, 60-Hz transformer has the following test results:
- Open-circuit test (HV side open): 100 V, 6 A, 400 W Short-circuit test (LV side shorted): 50 V, 100 A, 1800 W
- Draw the equivalent circuit of the transformer referred to the high-voltage side. Label impedances numerically in ohms and in per unit.
- Determine the voltage regulation at rated secondary current with 0.6 power factor lagging. Assume the primary is supplied with rated voltage
- Determine the efficiency of the transformer when the secondary current is 75% of its rated value and the power factor at the load is 0.8 lagging with a secondary voltage of 98 V across the load

Three-phase induction motor

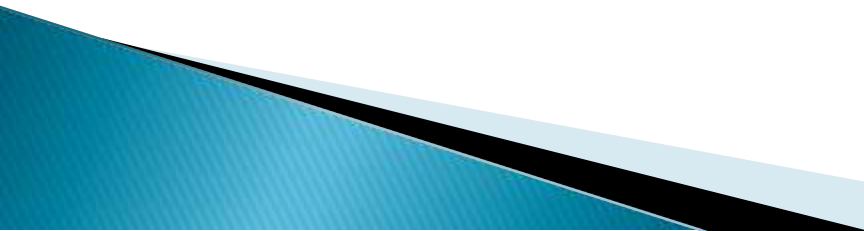
- Three-phase induction motors are the most common and frequently encountered machines in industry
 - simple design, rugged, low-price, easy maintenance
 - wide range of power ratings: fractional horsepower to 10 MW
 - run essentially as constant speed from no-load to full load
 - Its speed depends on the frequency of the power source
 - not easy to have variable speed control
 - requires a variable-frequency power-electronic drive for optimal speed control
- 

Construction

- An induction motor has two main parts
 - a stationary stator
 - consisting of a steel frame that supports a hollow, cylindrical core
 - core, constructed from stacked laminations (why?), having a number of evenly spaced slots, providing the space for the stator winding

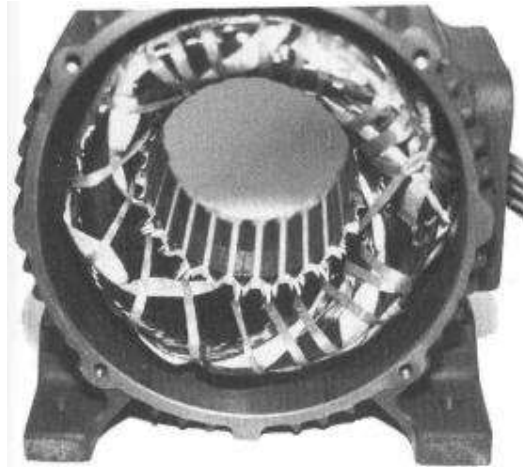

Stator of IM

Construction

- a revolving rotor
 - composed of punched laminations, stacked to create a series of rotor slots, providing space for the rotor winding
 - one of two types of rotor windings
 - conventional 3-phase windings made of insulated wire (**wound-rotor**)
- » similar to the winding on the stator
 - aluminum bus bars shorted together at the ends by two aluminum rings, forming a squirrel-cage shaped circuit (**squirrel-cage**)
- Two basic design types depending on the rotor design
 - squirrel-cage: conducting bars laid into slots and shorted at both ends by shorting rings.
 - wound-rotor: complete set of three-phase windings exactly as the stator. Usually Y-connected, the ends of the three rotor wires are connected to 3 slip rings on the rotor shaft. In this way, the rotor circuit is accessible.

Construction

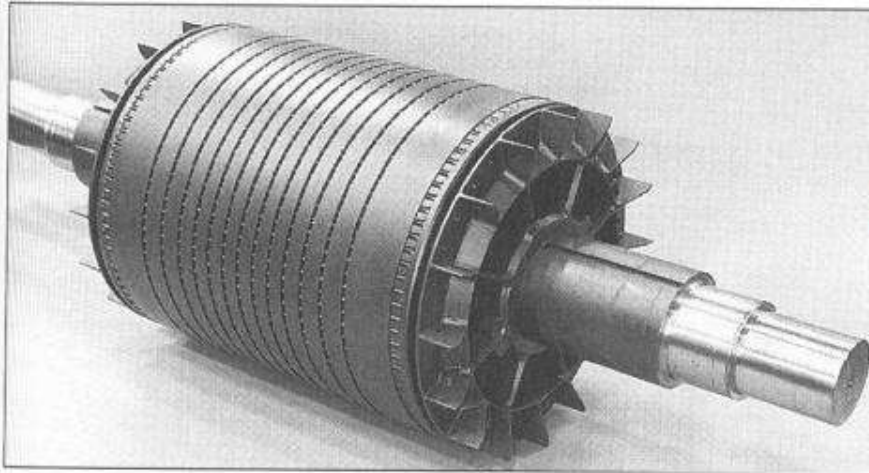

Squirrel cage rotor

Wound rotor

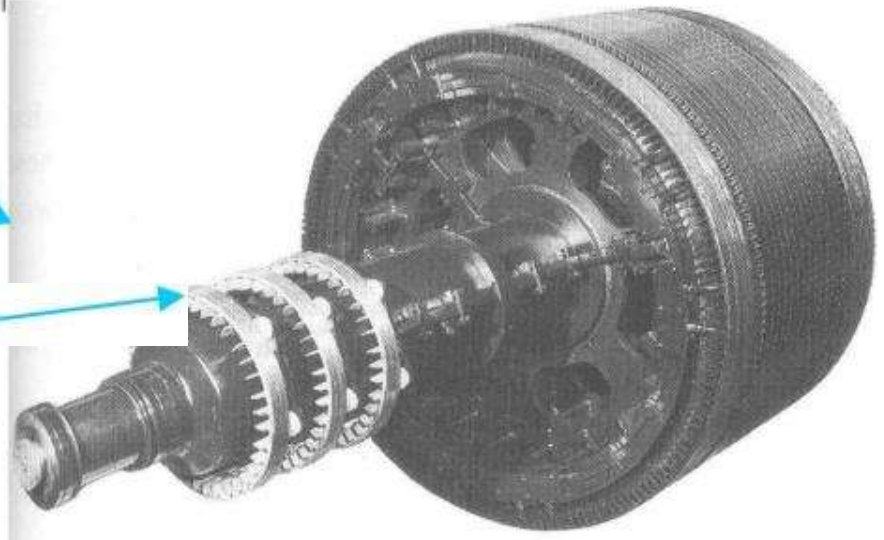

Notice the slip rings

Rotating Magnetic Field

- Balanced three phase windings, i.e. mechanically displaced 120 degrees from each other, fed by balanced three phase source
- A rotating magnetic field with constant magnitude is produced, rotating with a speed

$$n_{sync} = \frac{120 f_e}{P} \quad \begin{matrix} rpm \\ rpm \end{matrix}$$

Where f_e is the supply frequency and P is the no. of poles and n_{sync} is called the synchronous speed in rpm (revolutions per minute)

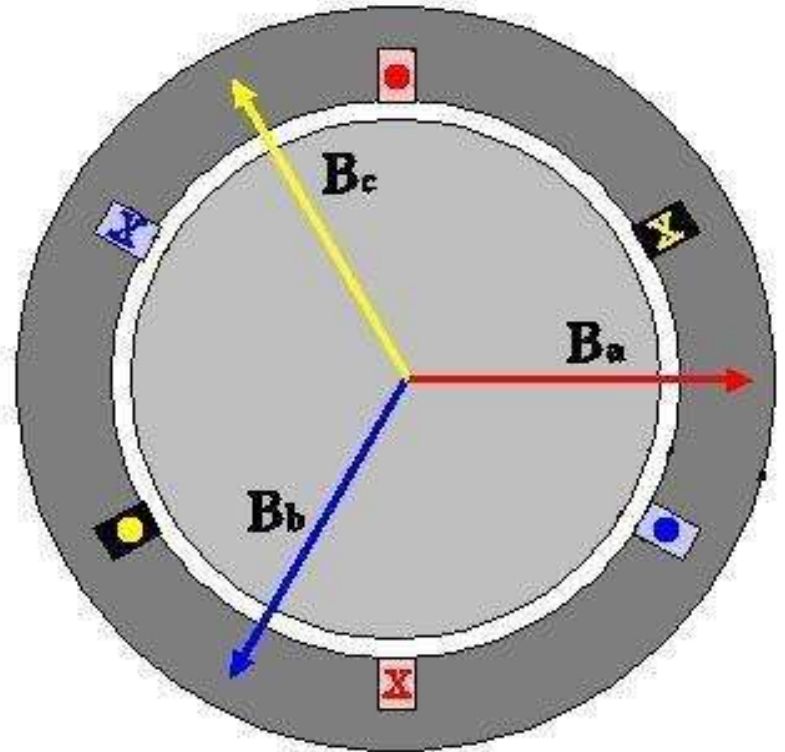

Rotating Magnetic Field

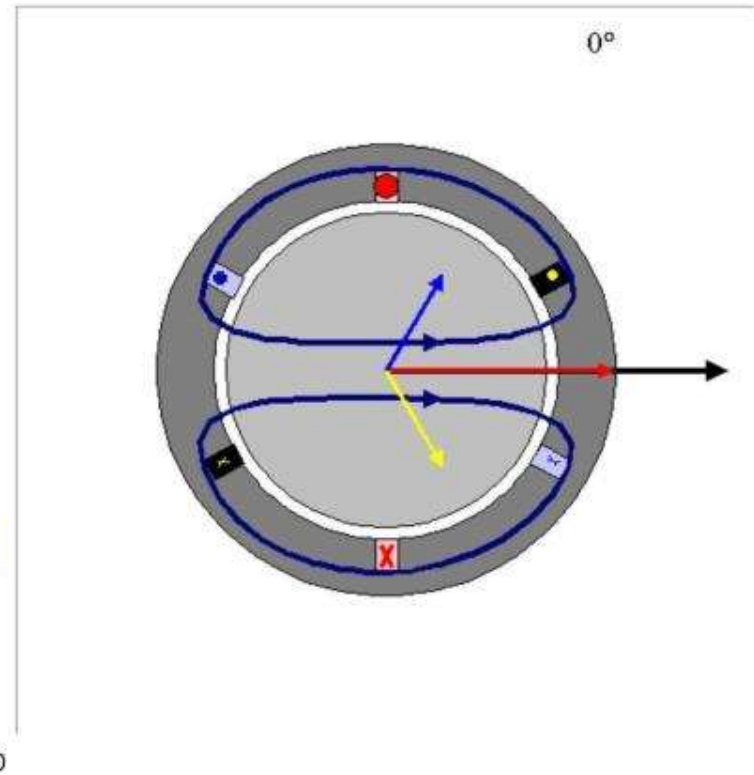
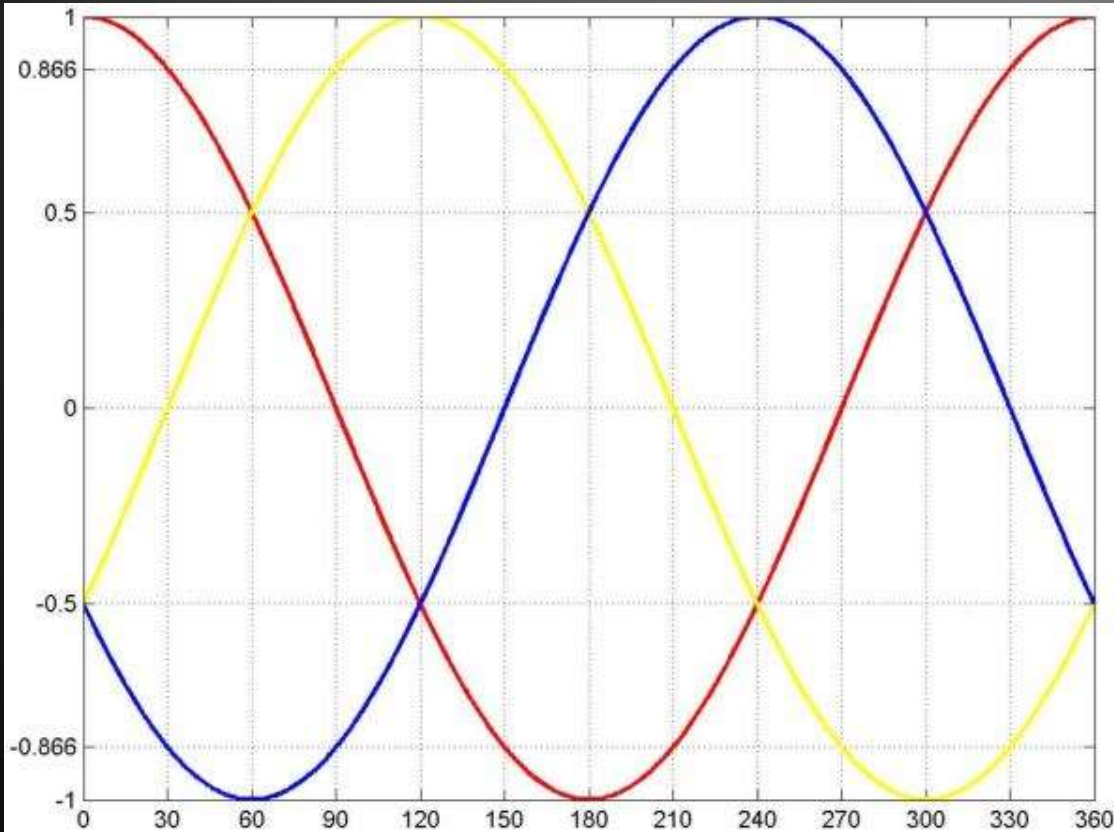

Rotating Magnetic Field

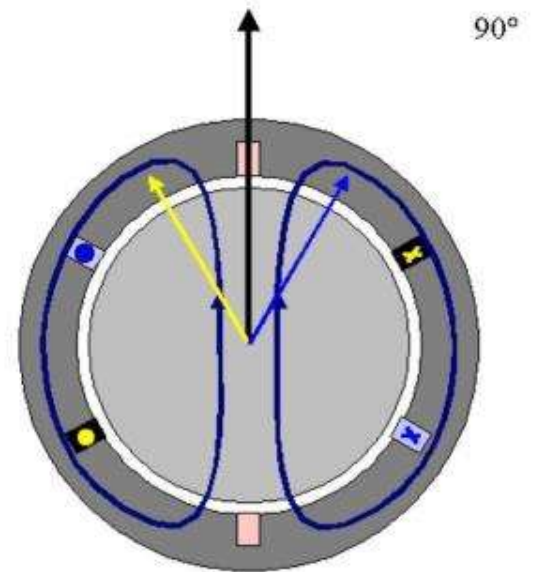
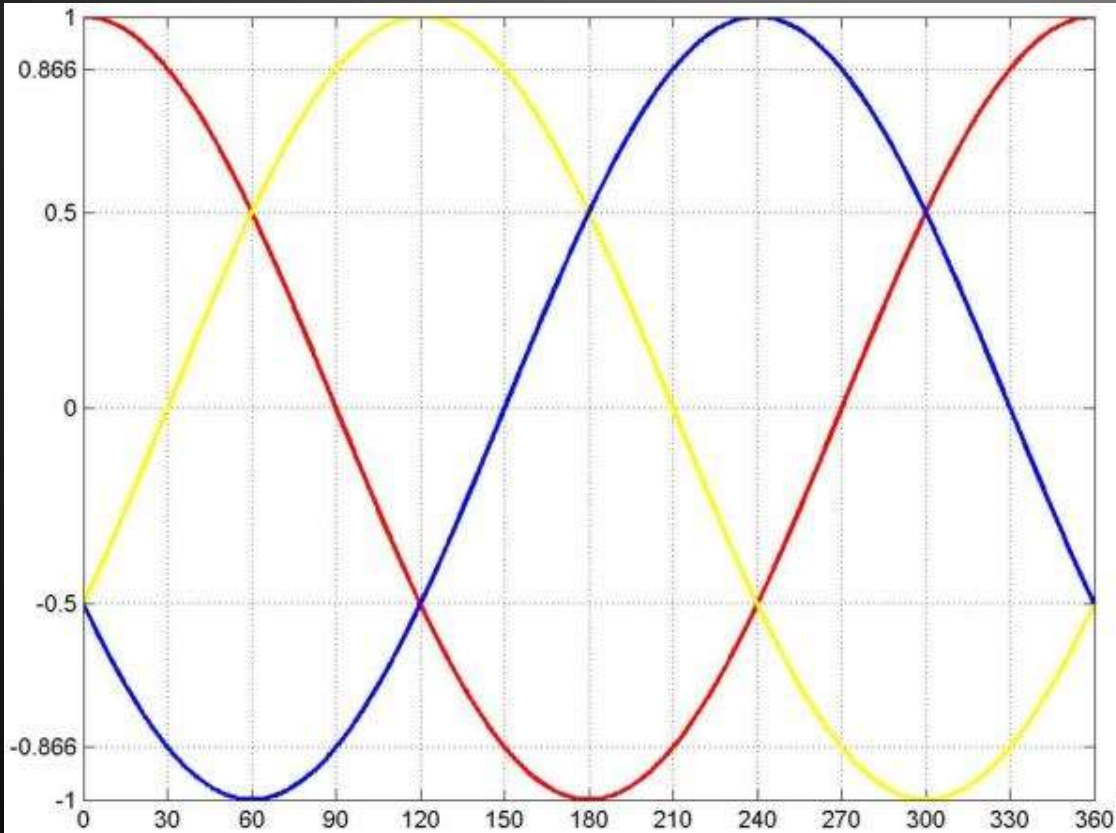

Rotating Magnetic Field

$$B_{net}(t) = B_a(t) + B_b(t) + B_c(t)$$

$$= B_M \sin(\omega t) \angle 0^\circ + B_M \sin(\omega t - 120^\circ) \angle 120^\circ + B_M \sin(\omega t - 240^\circ) \angle 240^\circ$$

$$= B_M \sin(\omega t) \hat{x}$$

$$- [0.5 B_M \sin(\omega t - 120^\circ)] \hat{x} - \left[\frac{\sqrt{3}}{2} B_M \sin(\omega t - 120^\circ) \right] \hat{y}$$

$$- [0.5 B_M \sin(\omega t - 240^\circ)] \hat{x} + \left[\frac{\sqrt{3}}{2} B_M \sin(\omega t - 240^\circ) \right] \hat{y}$$

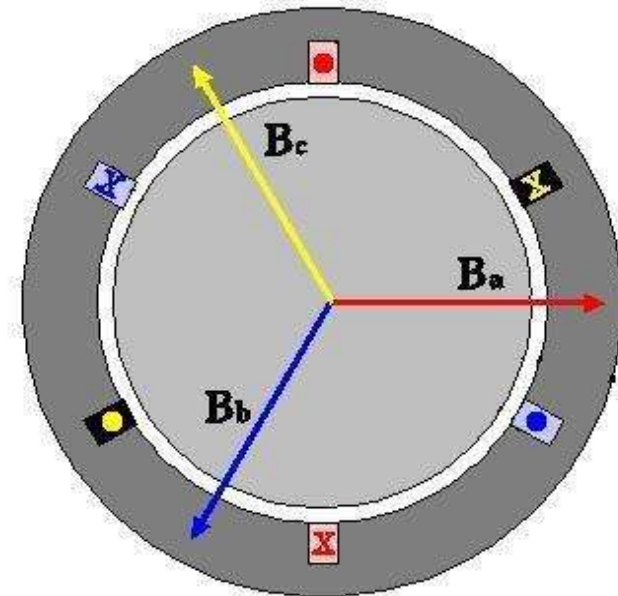

Rotating Magnetic Field

$$\begin{aligned}
 \mathbf{B}_{net}(t) &= \left[\frac{1}{4} B_M \sin(\omega t) + \frac{\sqrt{3}}{4} B_M \cos(\omega t) \right] \hat{x} + \left[\frac{1}{4} B_M \sin(\omega t) - \frac{\sqrt{3}}{4} B_M \cos(\omega t) \right] \hat{y} \\
 &+ \left[-\frac{\sqrt{3}}{4} B_M \sin(\omega t) + \frac{3}{4} B_M \cos(\omega t) \right] \hat{x} + \left[\frac{\sqrt{3}}{4} B_M \sin(\omega t) + \frac{3}{4} B_M \cos(\omega t) \right] \hat{y} \\
 &= [1.5 B_M \sin(\omega t)] \hat{x} - [1.5 B_M \cos(\omega t)] \hat{y}
 \end{aligned}$$

Rotating Magnetic Field

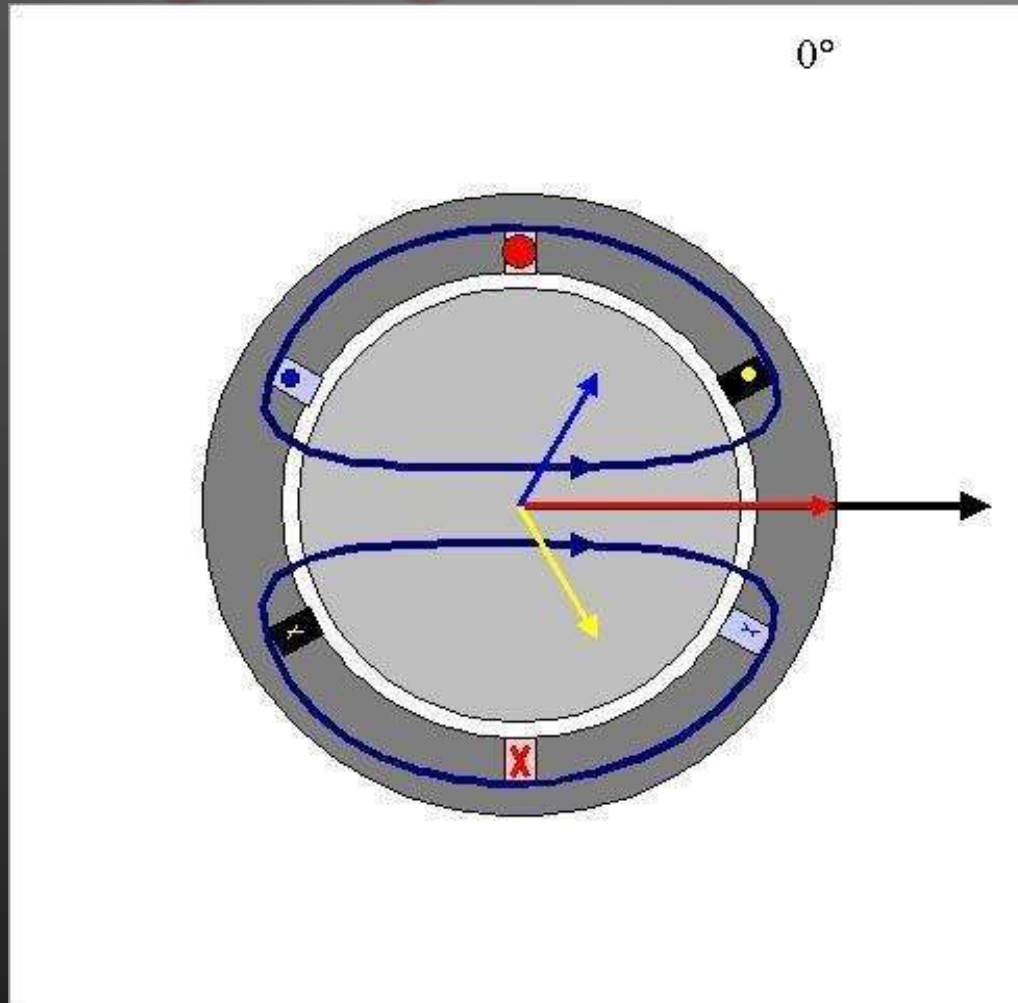

Principle of operation

- This rotating magnetic field cuts the rotor windings and produces an induced voltage in the rotor windings
- Due to the fact that the rotor windings are short circuited, for both squirrel cage and wound-rotor, and induced current flows in the rotor windings
- The rotor current produces another magnetic field
- A torque is produced as a result of the interaction of those two magnetic fields

$$\tau_{ind} = k B_R \times B_s$$

Where τ_{ind} is the induced torque and B_R and B_s are the magnetic flux densities of the rotor and the stator respectively

Induction motor speed

- So, the IM will always run at a speed **lower** than the synchronous speed
- The difference between the motor speed and the synchronous speed is called the **Slip**

$$n_{slip} = n_{sync} - n_m$$

$$n_{slip} = n_{sync} - n_m$$

Where n_{slip} = slip speed

n_{sync} = speed of the magnetic field

n_m = mechanical shaft speed of the motor

The Slip

$$s = \frac{n_{sync} - n_m}{n_{sync}}$$

Where s is the *slip*

Notice that : if the rotor runs at synchronous speed

$$s = 0$$

if the rotor is stationary

$$s = 1$$

Slip may be expressed as a **percentage** by multiplying the above eq. by 100, notice that the slip is a ratio and doesn't have units

Induction Motors and Transformers

- Both IM and transformer works on the principle of induced voltage
 - Transformer: voltage applied to the **primary** windings produce an induced voltage in the **secondary** windings
 - Induction motor: voltage applied to the **stator** windings produce an induced voltage in the **rotor** windings
 - The difference is that, in the case of the induction motor, the secondary windings can **move**
 - Due to the rotation of the rotor (the secondary winding of the IM), the induced voltage in it **does not** have the same frequency of the stator (the primary) voltage

Frequency

- The frequency of the voltage induced in the rotor is given by $f_r = \frac{P \times n}{120}$

r

Where f_r = the rotor frequency (Hz)

P = number of stator poles

n = slip speed (rpm)

$$f_r = \frac{P \times (n_s - n_m)}{120}$$

$$= \frac{P \times s n_s}{120} = s f_e$$

Frequency

- What would be the frequency of the rotor's induced voltage at any speed n_m ?

$$f_r = s f_e$$

- When the rotor is blocked ($s=1$), the frequency of the induced voltage is equal to the supply frequency
- On the other hand, if the rotor runs at synchronous speed ($s = 0$), the frequency will be zero

Torque

- While the input to the induction motor is electrical power, its output is mechanical power and for that we should know some terms and quantities related to mechanical power
- Any mechanical load applied to the motor shaft will introduce a **Torque** on the motor shaft. This torque is related to the motor output power and the rotor speed

$$\tau_{load} = \frac{P_{out}}{\omega_m} \text{ N.m}$$

and

$$\omega_m = \frac{2\pi n}{60} \text{ rad/s}$$

Synchronous Machines And Characteristics



Synchronous Machines



*Gas/Steam
Turbines*



Diesel

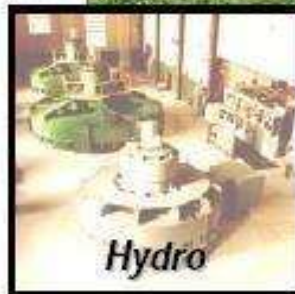
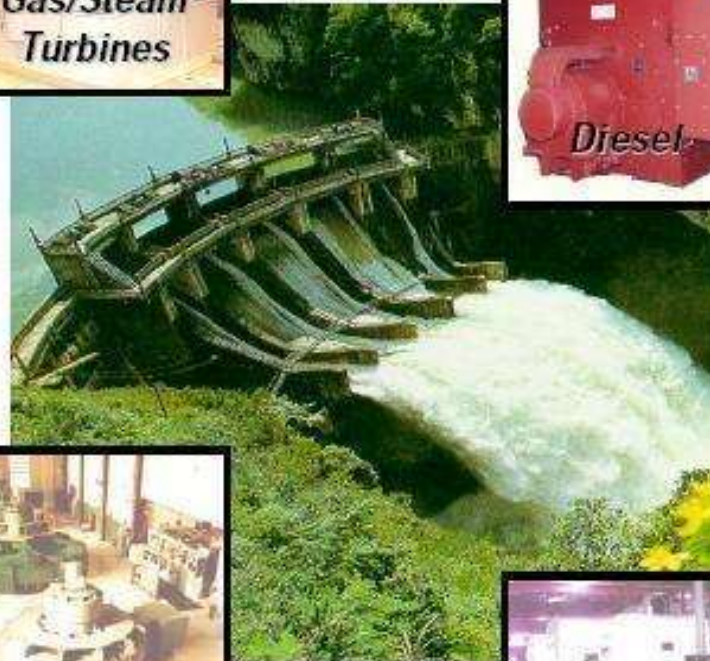

Hydro



*Special
Applications*

Synchronous Machines

- *Synchronous generators* or *alternators* are used to convert mechanical power derived from steam, gas, or hydraulic-turbine to ac electric power
- Synchronous generators are the primary source of electrical energy we consume today
- Large ac power networks rely almost exclusively on synchronous generators
- *Synchronous motors* are built in large units compare to induction motors (Induction motors are cheaper for smaller ratings) and used for constant speed industrial drives

Construction



Basic parts of a synchronous generator:

- **Rotor - dc excited winding**
- **Stator - 3-phase winding in which the ac emf is generated**



The manner in which the active parts of a synchronous machine are cooled determines its overall physical size and structure

Various Types

- **Salient-pole synchronous machine**
- **Cylindrical or round-rotor synchronous machine**

Salient-Pole Synchronous Generator

1. Most hydraulic turbines have to turn at low speeds (between 50 and 300 r/min)
2. A large number of poles are required on the rotor

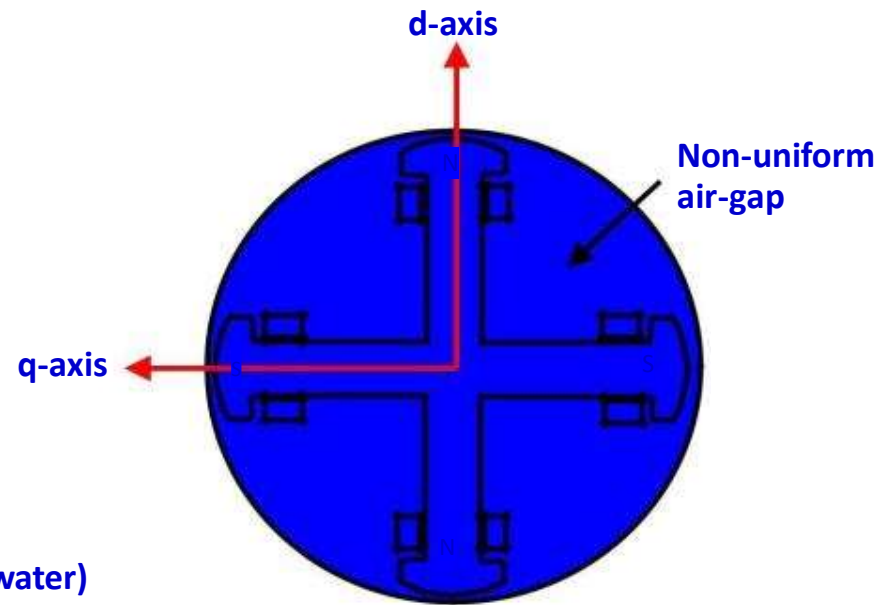
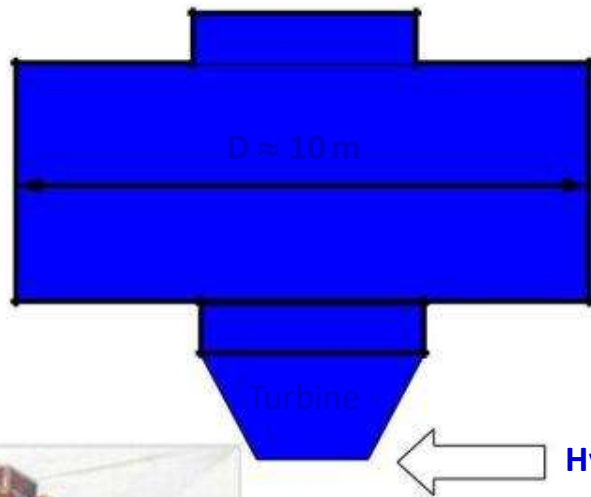

Hydrogenerator

Salient-Pole Synchronous Generator

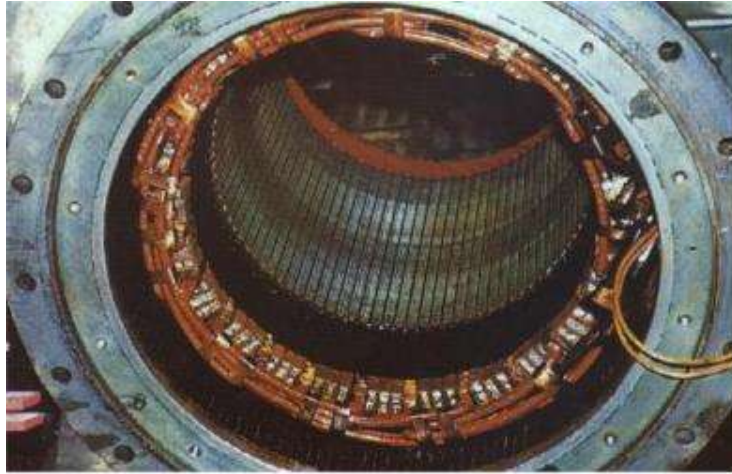

Stator



Salient-pole rotor

Cylindrical-Rotor Synchronous Generator

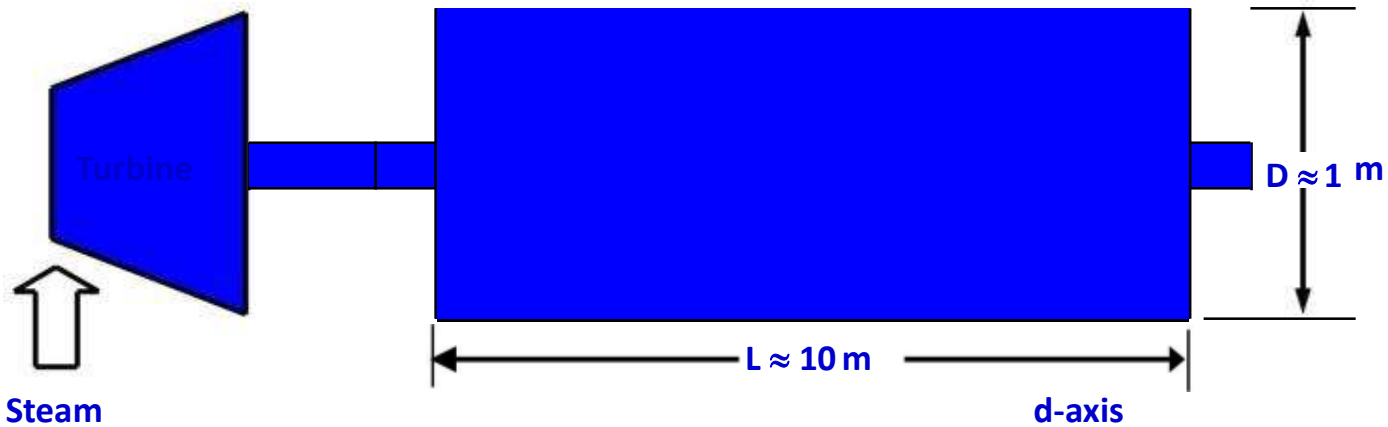

- High speed
- $3600 \text{ r/min} \Rightarrow 2\text{-pole}$
- $1800 \text{ r/min} \Rightarrow 4\text{-pole}$
- Direct-conductor cooling (using hydrogen or water as coolant)
- Rating up to 2000 MVA

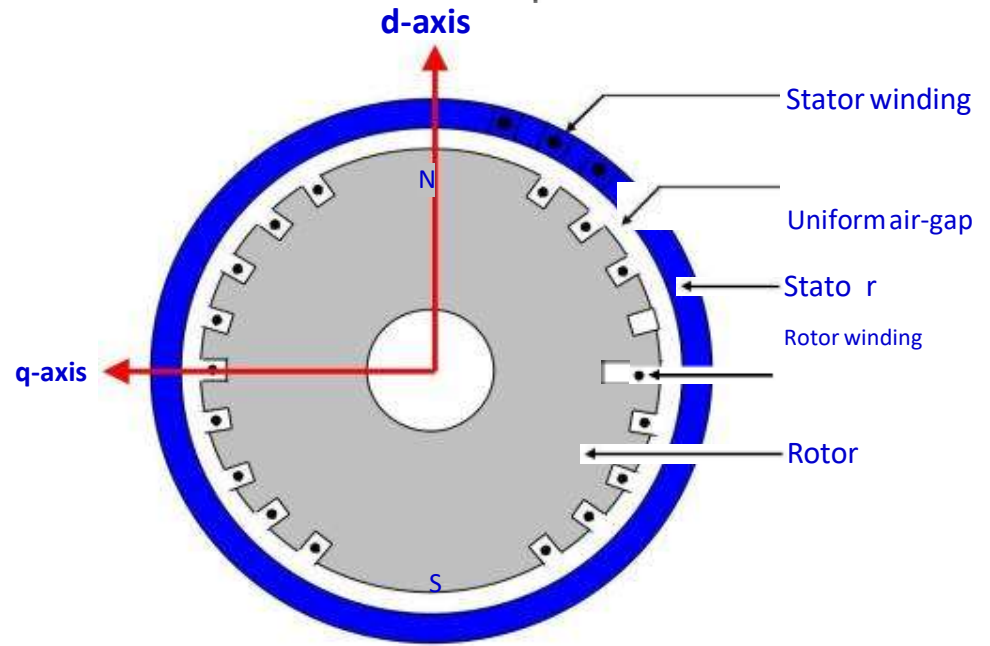

Turbogenerator

Cylindrical-Rotor Synchronous Generator



Stator

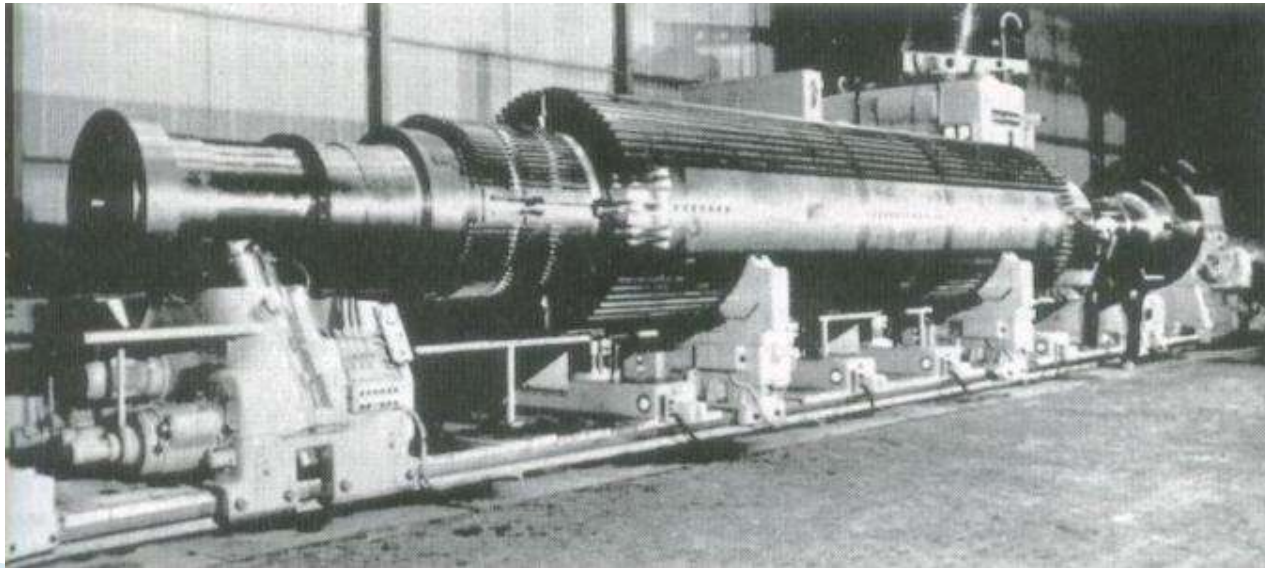

Cylindrical rotor

Operation Principle

The rotor of the generator is driven by a prime-mover



A dc current is flowing in the rotor winding which produces a rotating magnetic field within the machine



The rotating magnetic field induces a three-phase voltage in the stator winding of the generator

Generated Voltage

The generated voltage of a synchronous generator is given by

$$E = K_c \phi f_e$$

where ϕ = flux in the machine (function of I_f) f_e = electrical frequency

K_c = synchronous machine constant

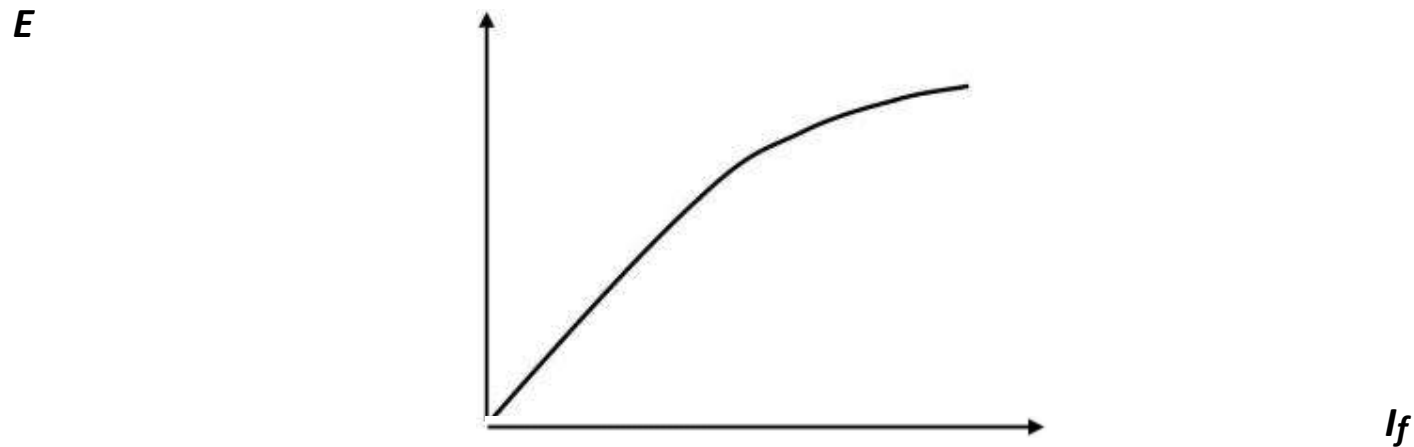

Saturation characteristic of a synchronous generator.

Equivalent Circuit_1

- o The internal voltage E_f produced in a machine is not usually the voltage that appears at the terminals of the generator.
- o The only time E_f is same as the output voltage of a phase is when there is no armature current flowing in the machine.
- o There are a number of factors that cause the difference between E_f and V_t :
 - The distortion of the air-gap magnetic field by the current flowing in the stator, called the armature reaction
 - The self-inductance of the armature coils.
 - The resistance of the armature coils.
 - The effect of salient-pole rotor shapes.

Equivalent Circuit_2

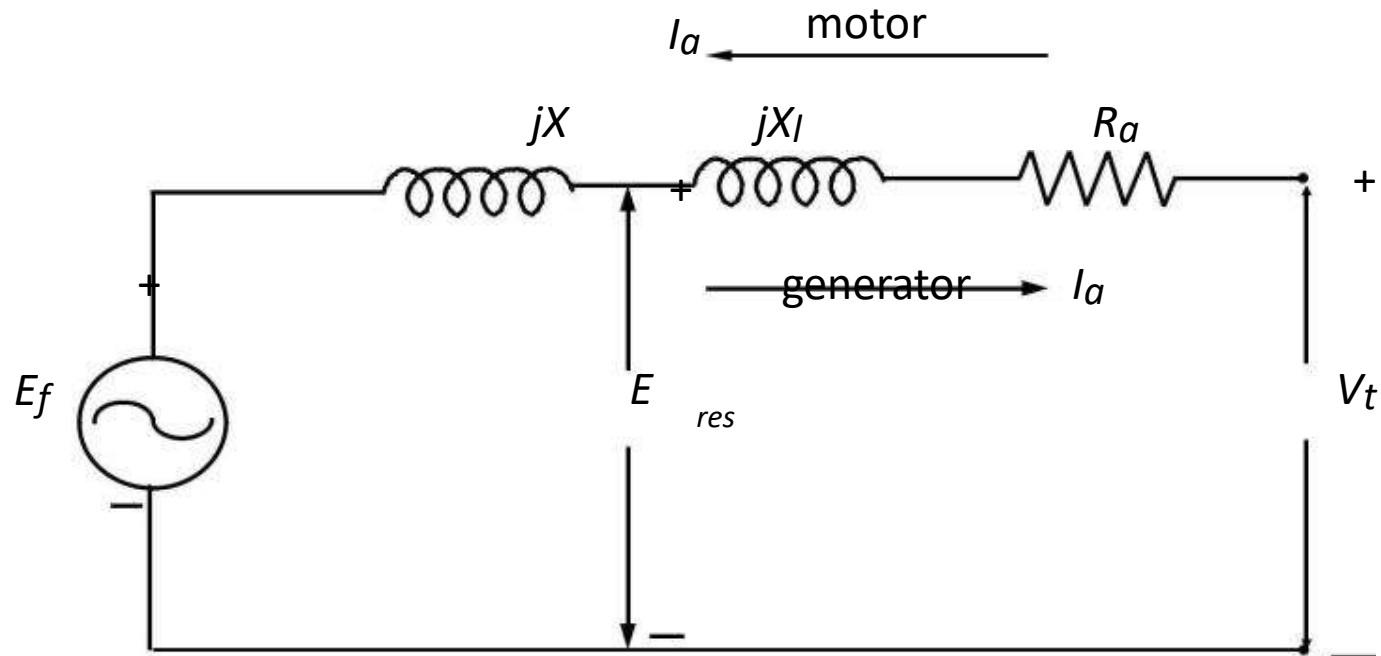

Equivalent circuit of a cylindrical-rotor synchronous machine

Phasor Diagram

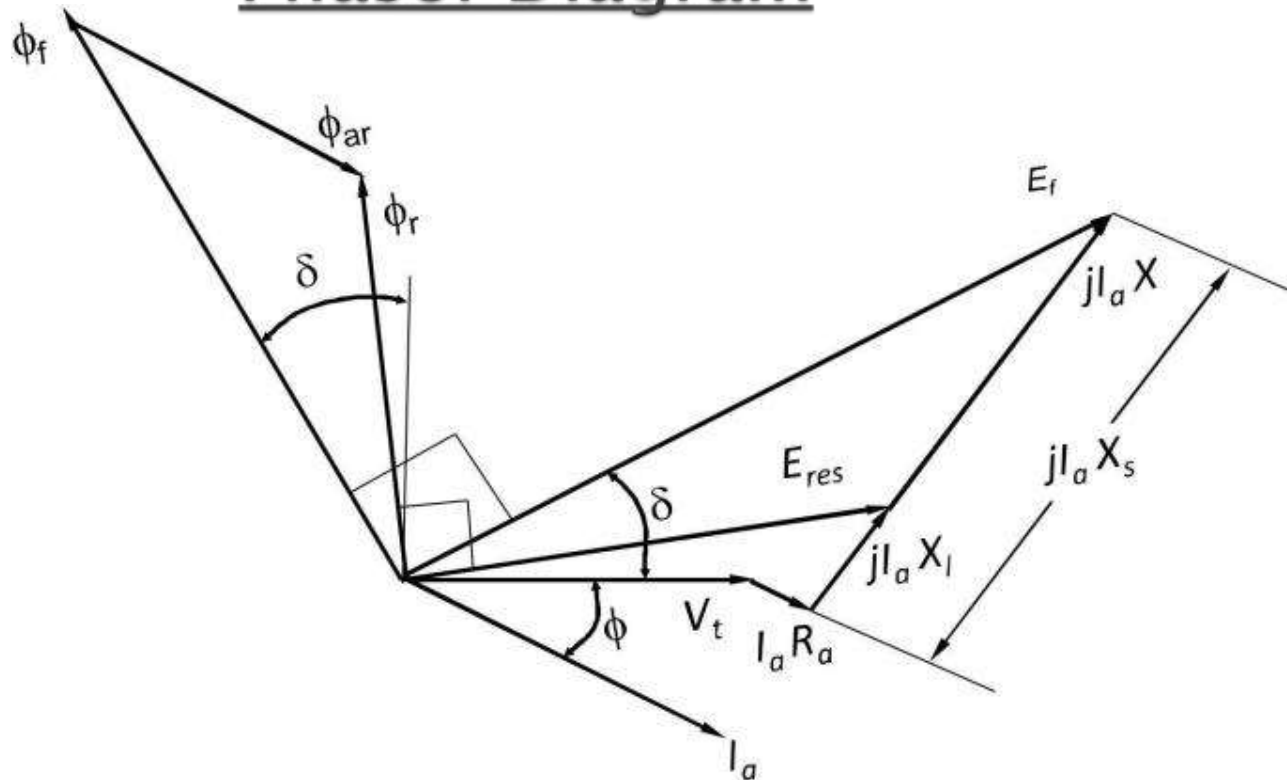

Phasor diagram of a cylindrical-rotor synchronous generator, for the case of lagging power factor

Lagging PF: $|V_t| < |E_f|$ for overexcited condition

Leading PF: $|V_t| > |E_f|$ for underexcited condition

Three-phase equivalent circuit of a cylindrical-rotor synchronous machine

The voltages and currents of the three phases are 120° apart in angle, but otherwise the three phases are identical.

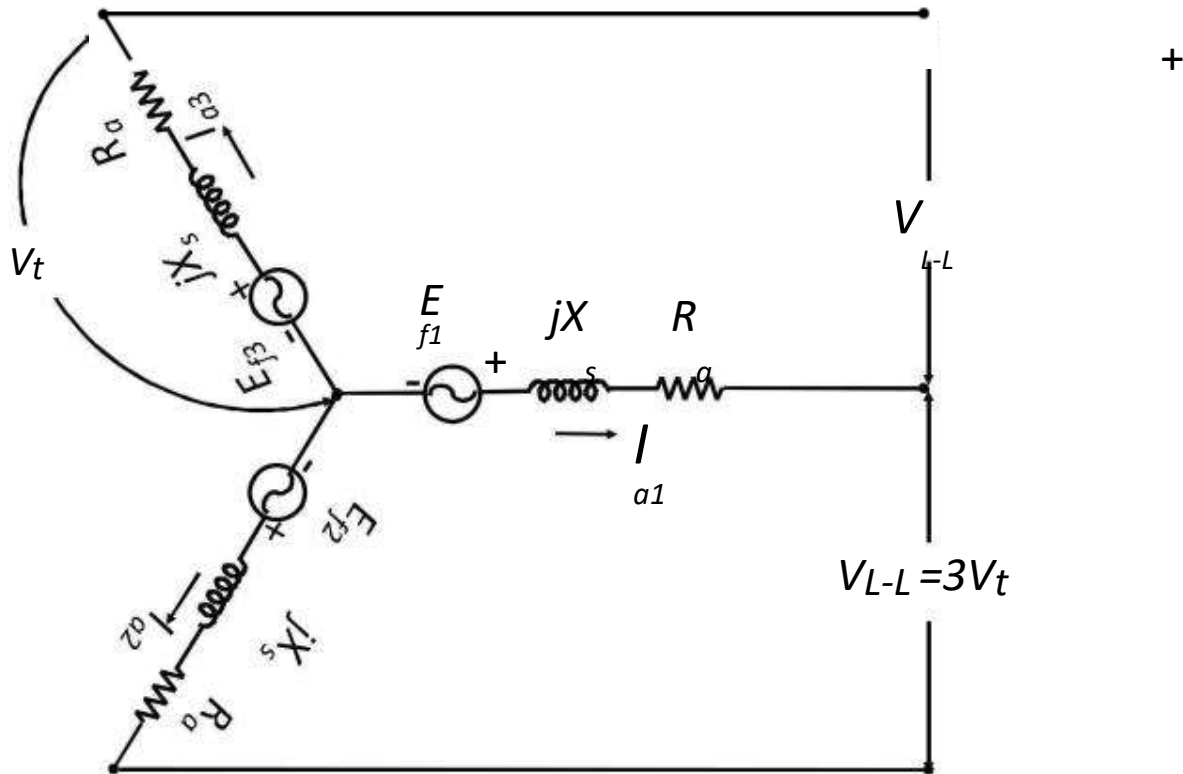

DETERMINATION OF THE PARAMETERS OF THE EQUIVALENT CIRCUIT FROM TEST DATA

- The equivalent circuit of a synchronous generator that has been derived contains three quantities that must be determined in order to completely describe the behaviour of a real synchronous generator:
 - The saturation characteristic: relationship between I_f and ϕ (and therefore between I_f and E_f)
 - The synchronous reactance, X_s
 - The armature resistance, R_a
- The above three quantities could be determined by performing the following three tests:
 - Open-circuit test
 - Short-circuit test
 - DC test

Regulation of Synchronous Generator

Voltage Regulation

A convenient way to compare the voltage behaviour of two generators is by their *voltage regulation (VR)*. The *VR* of a synchronous generator at a given load, power factor, and at rated speed is defined as

$$VR = \frac{E_{nl} - V_{fl}}{V_{fl}} \times 100\%$$

Where V_{fl} is the full-load terminal voltage, and E_{nl} (equal to E_f) is the no-load terminal voltage (internal voltage) at rated speed when the load is removed without changing the field current. For lagging power factor (*PF*), *VR* is fairly positive, for unity *PF*, *VR* is small positive and for leading *PF*, *VR* is negative.

EMFmethod

This method is also known as synchronous impedance method. Here the magnetic circuit is assumed to be unsaturated. In this method the MMFs (fluxes) produced by rotor and stator are replaced by their equivalent emf, and hence called emf method.

To predetermine the regulation by this method the following informations are to be determined. Armature resistance/phase of the alternator, open circuit and short circuit characteristics of the alternator.

Open-circuit test

- The generator is turned at the rated speed
- The terminals are disconnected from all loads, and the field current is set to zero.
- Then the field current is gradually increased in steps, and the terminal voltage is measured at each step along the way.
- It is thus possible to obtain an open-circuit characteristic of a generator (E_f or V_t versus I_f) from this information

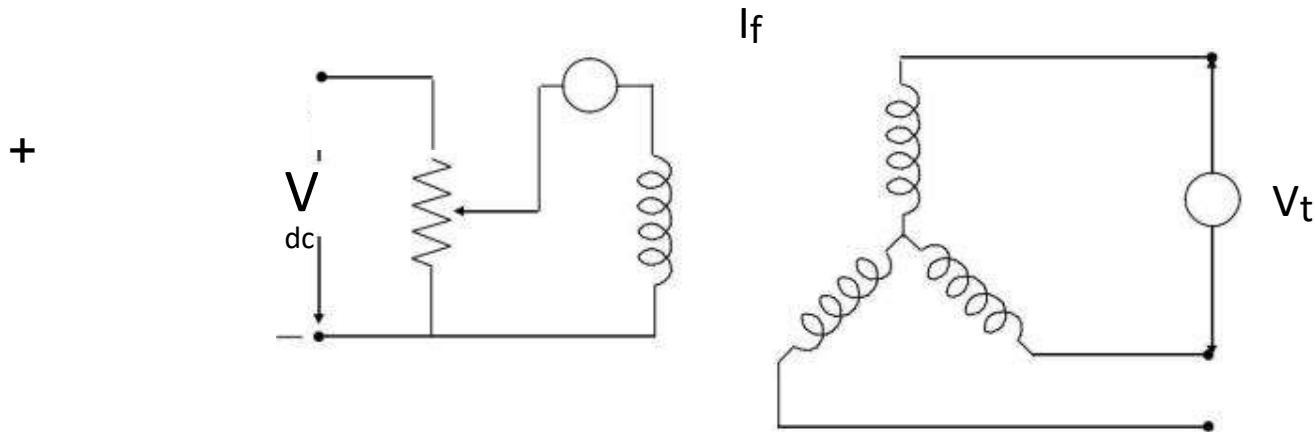

Short-circuit test

- Adjust the field current to zero and short-circuit the terminals of the generator through a set of ammeters.
- Record the armature current I_{sc} as the field current is increased.
- Such a plot is called short-circuit characteristic.

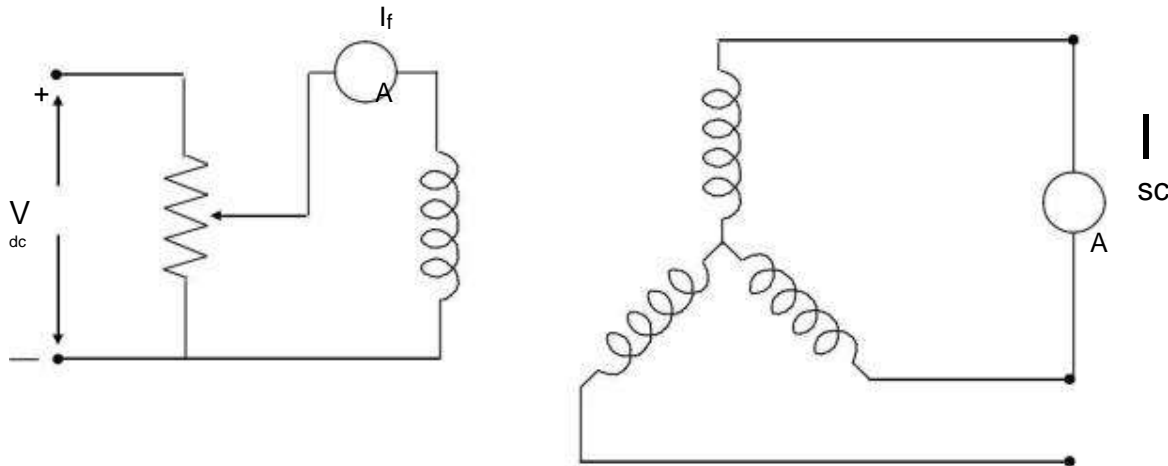

DC Test

- The purpose of the DC test is to determine R_a . A variable DC voltage source is connected between two stator terminals.
- The DC source is adjusted to provide approximately rated stator current, and the resistance between the two stator leads is determined from the voltmeter and ammeter readings

– then
$$R_{DC} = \frac{V_{DC}}{I_{DC}}$$

- If the stator is Y-connected, the per phase stator resistance is

$$R_a = \frac{R_{DC}}{2}$$

- If the stator is delta-connected, the per phase stator resistance is

$$R_a = \frac{2}{3} R_{DC}$$

Determination of X_s

- For a particular field current I_{fA} , the internal voltage $E_f (=V_A)$ could be found from the occ and the short-circuit current flow $I_{sc,A}$ could be found from the scc.
- Then the synchronous reactance X_s could be obtained using

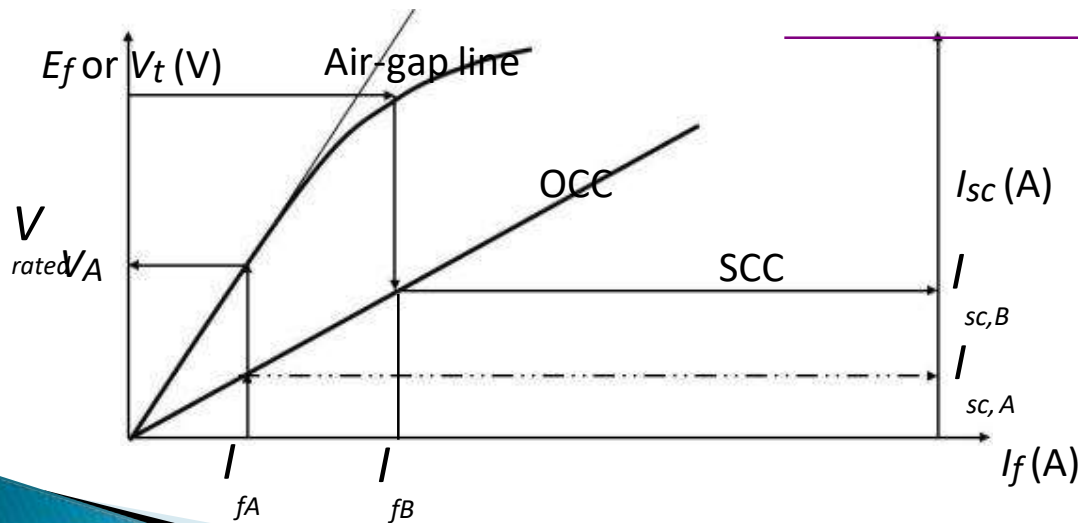

$$Z = \sqrt{R_a^2 + X_{s,unsat}^2} = \frac{V_A (= E_f)}{I_{scA}}$$

$$X_{s,unsat} = \sqrt{\frac{V_A^2}{I_{scA}^2} - R_a^2}$$

: R_a is known from the DC test.

Since $X_{s,unsat} \gg R_a$,

$$X_{s,unsat} \approx \frac{E_f}{I_{scA}} = \frac{V_{t,oc}}{I_{scA}}$$

X_s under saturated condition

At $V = V_{rated}$,

$$Z_{s, sat} = \sqrt{R_a^2 + X_{s, sat}^2} = \frac{V_{rated} (\bar{E}_f)}{|I_{scB}|}$$

$$X_{s, sat} = \sqrt{Z_{s, sat}^2 - R_a^2}$$

: R is known from the DC test.

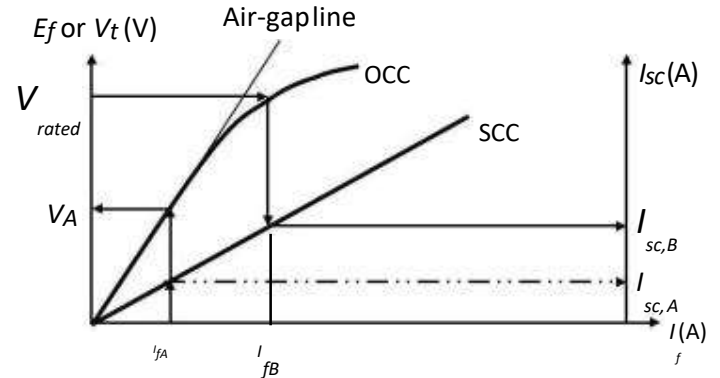

Equivalent circuit and phasor diagram under condition

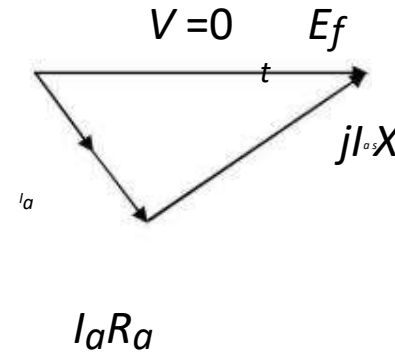
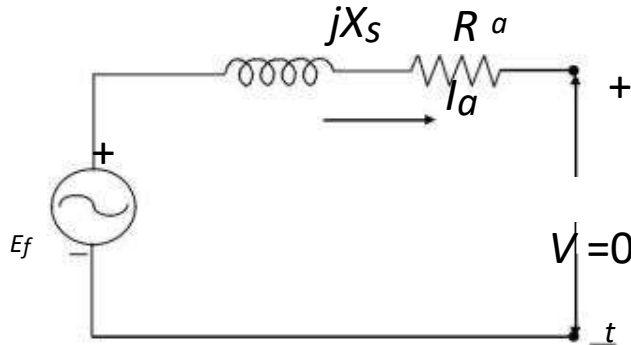

UNIT IV
SEMICONDUCTOR DIODE AND APPLICATIONS

Overview

- ▶ Introduction
 - ▶ What are P-type and N-type semiconductors??
 - ▶ What are Diodes?
 - ▶ Forward Bias & Reverse Bias
 - ▶ Characteristics Of Ideal Diode
 - ▶ Shockley Equation
 - ▶ I - V Characteristics of Diodes
- 

Introduction

Semiconductors are materials whose electrical properties lie between Conductors and Insulators.

Ex : Silicon and Germanium

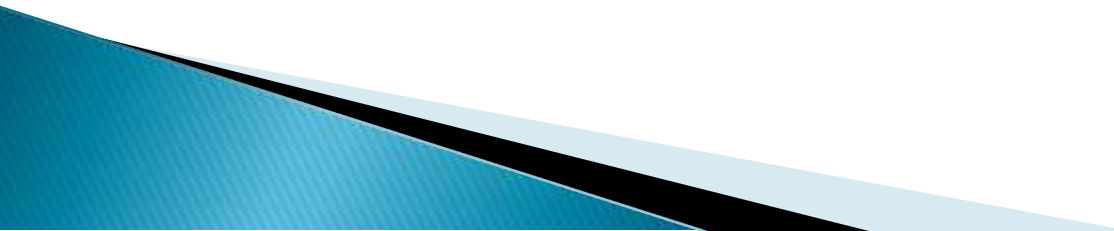

What are P-type and N-type ?

- ▶ Semiconductors are classified into P-type and N-type semiconductor
 - ▶ P-type: A P-type material is one in which holes are majority carriers i.e. they are positively charged materials (++++)
 - ▶ N-type: A N-type material is one in which electrons are majority charge carriers i.e. they are negatively charged materials (-----)
- 

Diodes

Electronic devices created by bringing together a p -type and n -type region within the same semiconductor lattice. Used for rectifiers, LED etc

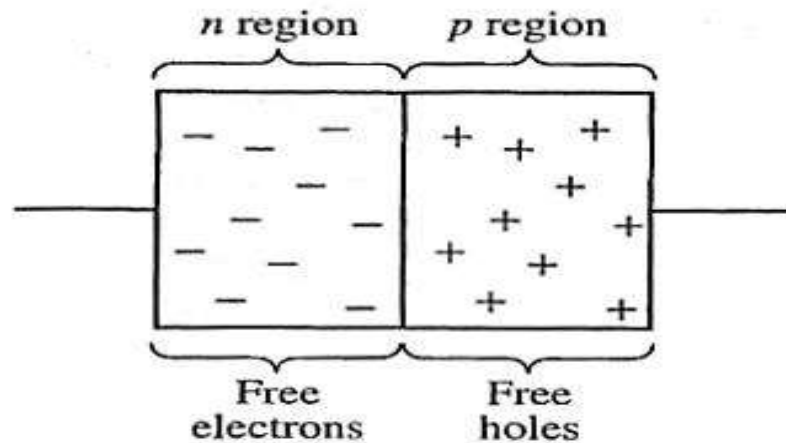

Diodes

It is represented by the following symbol, where the arrow indicates the direction of positive current flow.

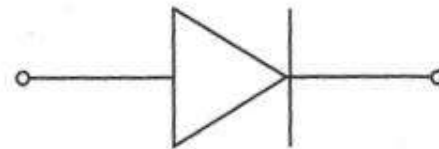
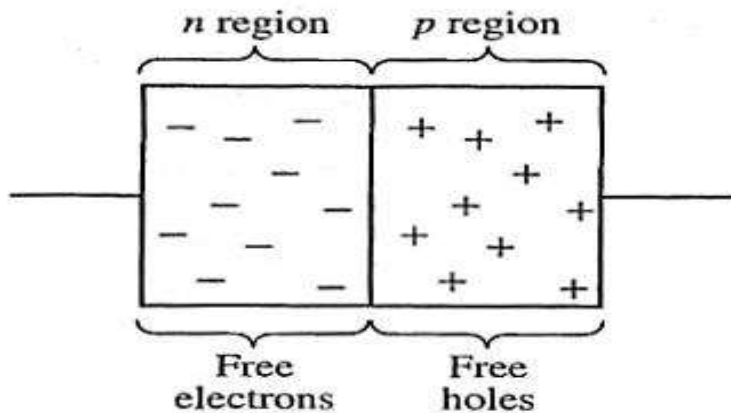

Forward Bias and Reverse Bias

- ▶ Forward Bias : Connect positive of the Diode to positive of supply...negative of Diode to negative of supply
- ▶ Reverse Bias: Connect positive of the Diode to negative of supply...negative of diode to positive of supply.

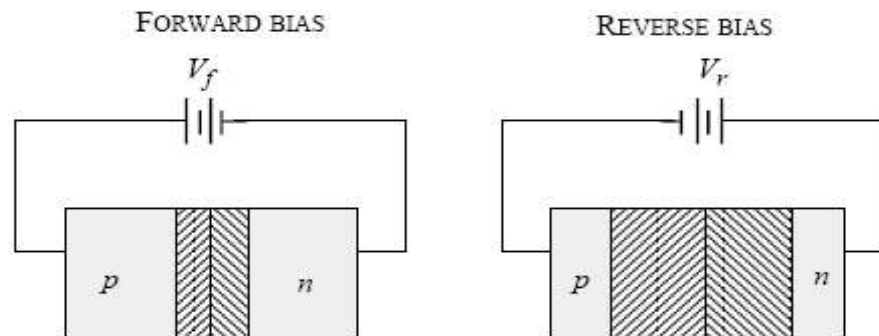

Characteristics of Diode

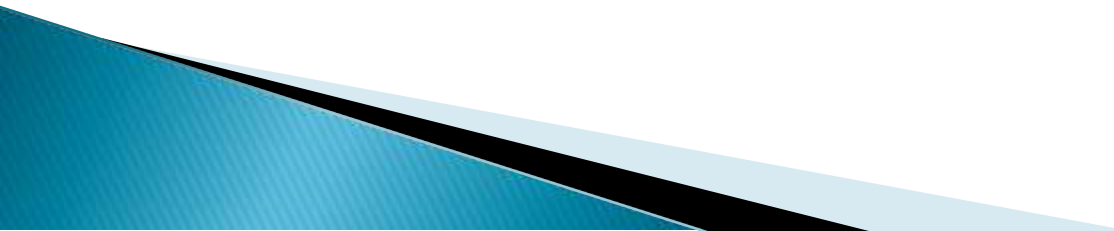
- ▶ Diode always conducts in one direction.
 - ▶ Diodes always conduct current when “Forward Biased” (Zero resistance)
 - ▶ Diodes do not conduct when Reverse Biased (Infinite resistance)
- 

I-V characteristics of Ideal diode

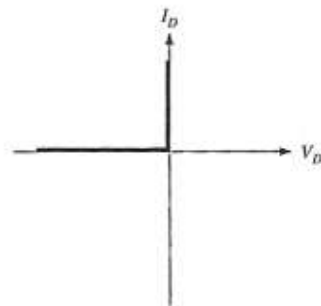

I-V Characteristics of Practical Diode

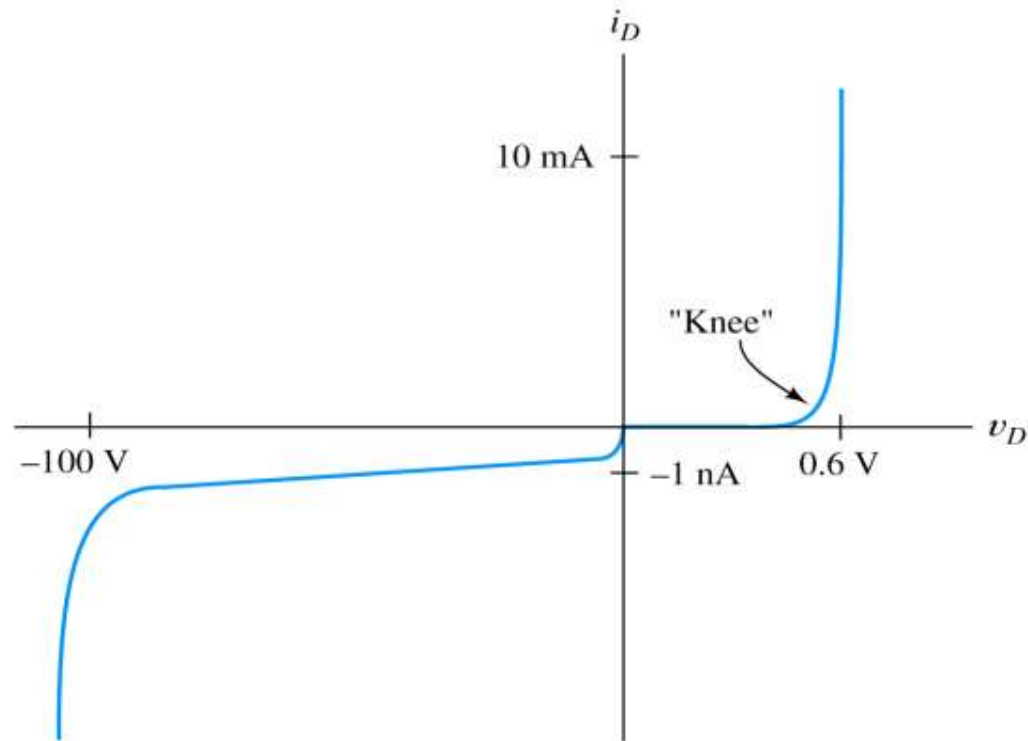
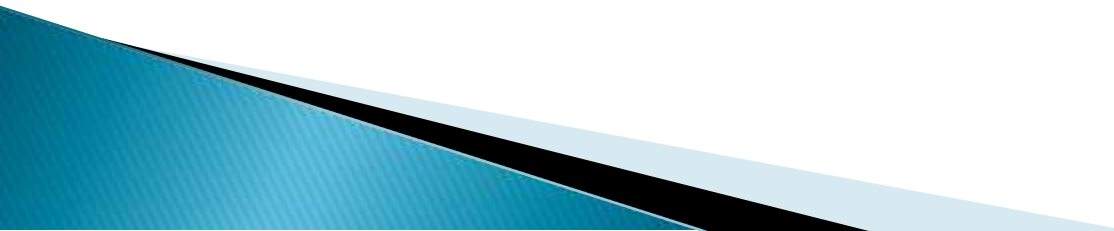

Figure 10.2 Volt-ampere characteristic for a typical small-signal silicon diode at a temperature of 300 K. Notice the change of scale for negative current and voltage.

Rectification

- ▶ Converting ac to dc is accomplished by the process of rectification.
 - ▶ Two processes are used:
 - Half-wave rectification;
 - Full-wave rectification.
- 

Half-wave Rectification

- ▶ Simplest process used to convert ac to dc.
- ▶ A diode is used to clip the input signal excursions of one polarity to zero.

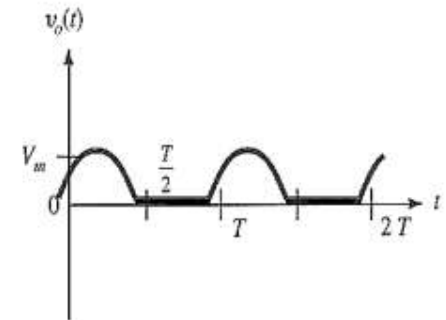
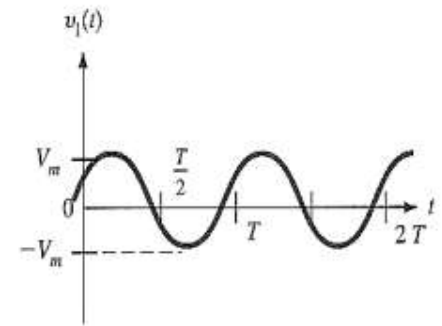
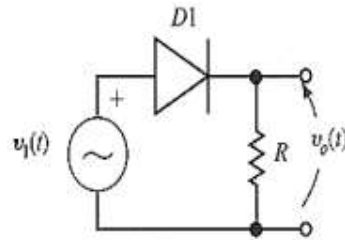

Shockley Equation

$$i_D = I_s \left[\exp\left(\frac{v_D}{nV_T}\right) - 1 \right] \quad V_T = \frac{kT}{q}$$

$$V_T \cong 26 \text{ mV}$$

I_s is the saturation current $\sim 10^{-14}$

V_d is the diode voltage

n – emission coefficient (varies from 1 - 2)

$k = 1.38 \times 10^{-23}$ J/K is Boltzmann's constant

$q = 1.60 \times 10^{-19}$ C is the electrical charge of an electron.

At a temperature of 300 K, we have

UNIT - V
BIPOLAR JUNCTION TRANSISTOR AND
APPLICATIONS

The BJT – Bipolar Junction Transistor

The Two Types of BJT Transistors:

npn

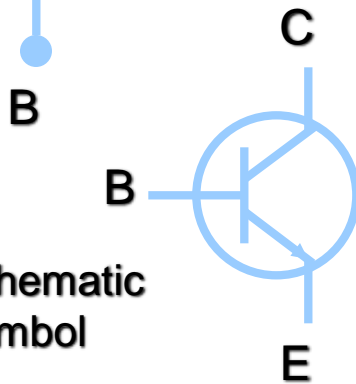
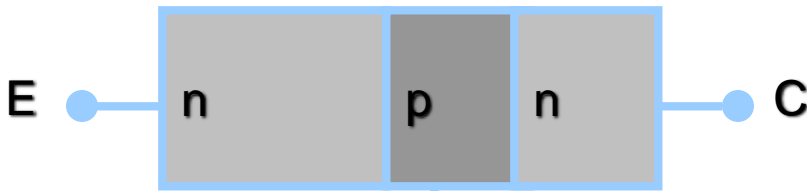

pnp

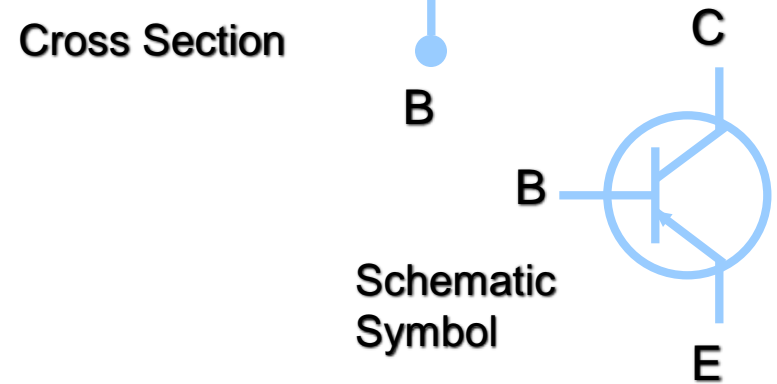
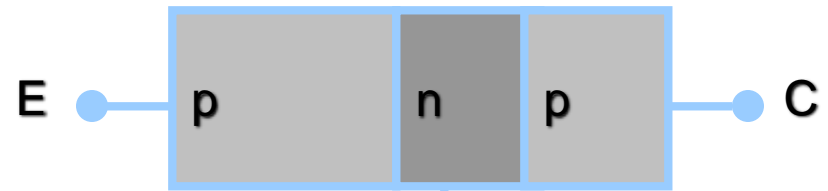

- Collector doping is usually $\sim 10^6$
- Base doping is slightly higher $\sim 10^7 - 10^8$
- Emitter doping is much higher $\sim 10^{15}$

BJT Relationships - Equations

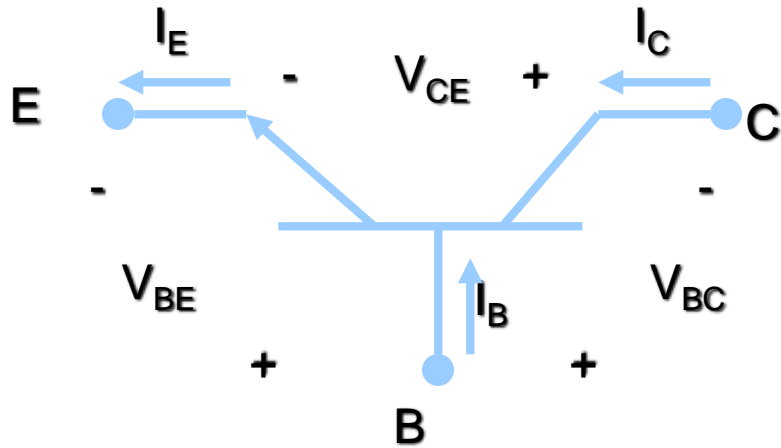

npn

$$I_E = I_B + I_C$$

$$V_{CE} = -V_{BC} + V_{BE}$$

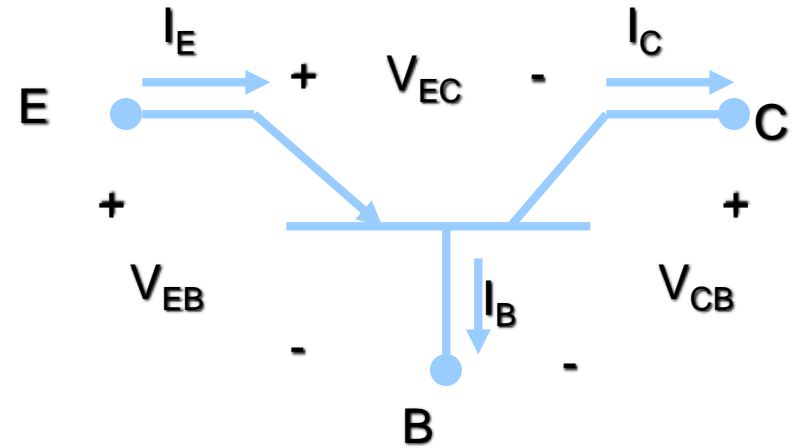

pnp

$$I_E = I_B + I_C$$

$$V_{EC} = V_{EB} - V_{CB}$$

Note: The equations seen above are for the transistor, not the circuit.

DC β and DC α

β = Common-emitter current gain

α = Common-base current gain

$$\beta = \frac{I_C}{I_B} \quad \alpha = \frac{I_C}{I_E}$$

The relationships between the two parameters are:

$$\alpha = \frac{\beta}{\beta + 1} \quad \beta = \frac{\alpha}{1 - \alpha}$$

Note: α and β are sometimes referred to as α_{dc} and β_{dc} because the relationships being dealt with in the BJT are DC.

BJT Example

Using Common-Base NPN Circuit Configuration

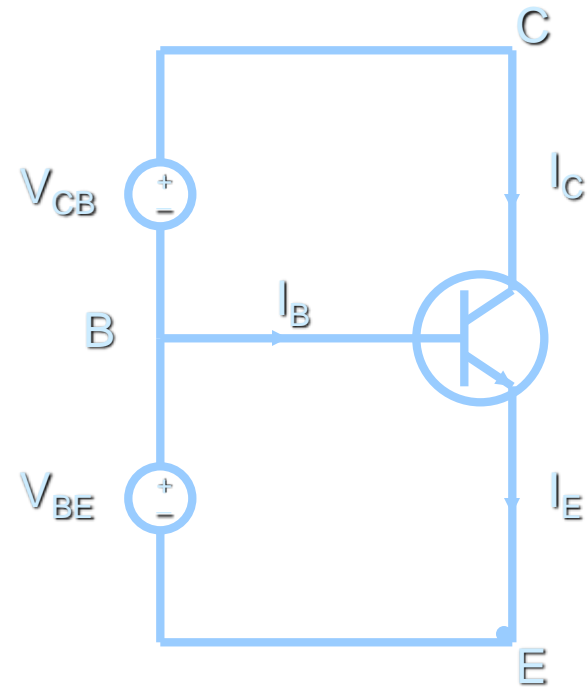

Given: $I_B = 50 \mu A$, $I_C = 1 \text{ mA}$

Find: I_E , β , and α

Solution:

$$I_E = I_B + I_C = 0.05 \text{ mA} + 1 \text{ mA} = 1.05 \text{ mA}$$

$$\beta = I_C / I_B = 1 \text{ mA} / 0.05 \text{ mA} = 20$$

$$\alpha = I_C / I_E = 1 \text{ mA} / 1.05 \text{ mA} = 0.95238$$

α could also be calculated using the value of β with the formula from the previous slide.

$$\alpha = \frac{\beta}{\beta + 1} = \frac{20}{21} = 0.95238$$

BJT Transconductance Curve

Typical NPN Transistor ¹

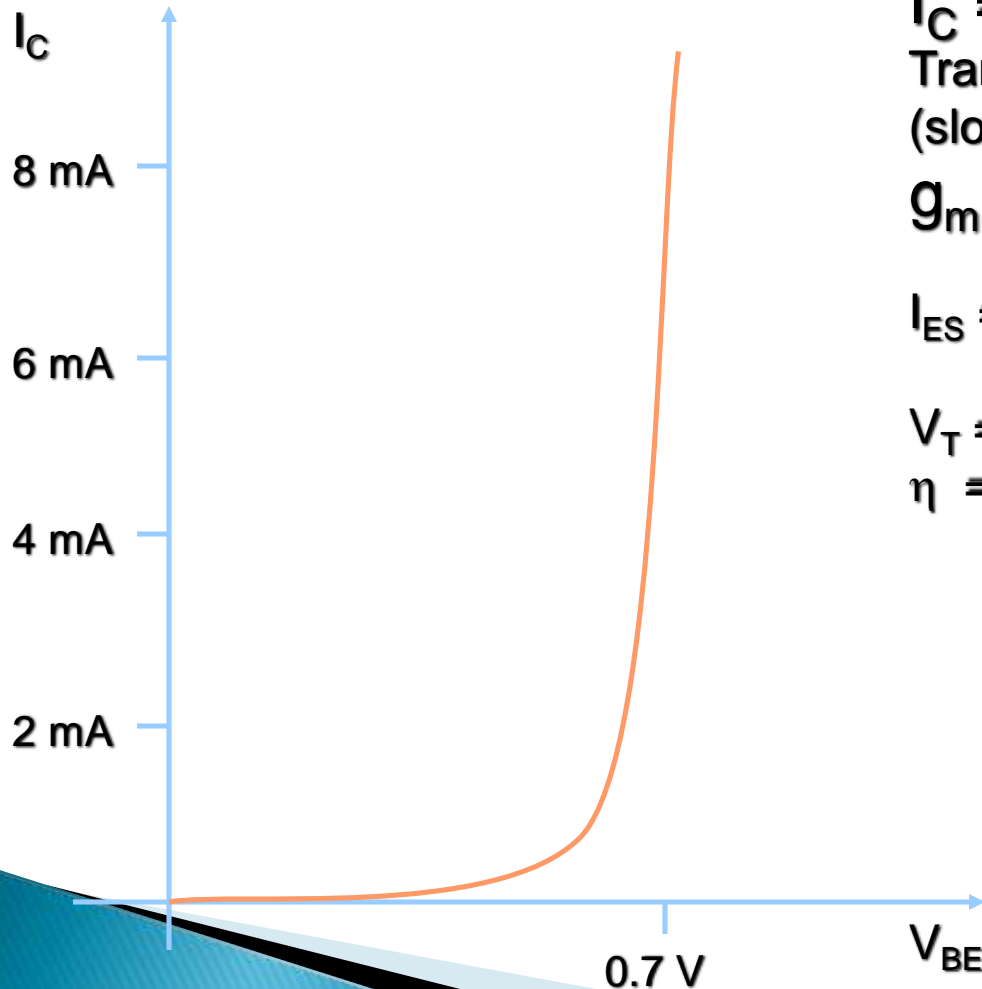

Collector Current:

$$I_C = \alpha I_{ES} e^{V_{BE}/\eta V_T}$$

Transconductance:
(slope of the curve)

$$g_m = \frac{dI_C}{dV_{BE}}$$

I_{ES} = The reverse saturation current
of the B-E Junction.

$$V_T = kT/q = 26 \text{ mV (@ } T=300\text{K)}$$

η = the emission coefficient and is
usually ~ 1

Modes of Operation

Active:

- **Most important mode of operation**
- **Central to amplifier operation**
- **The region where current curves are practically flat**

Saturation:

- **Barrier potential of the junctions cancel each other out causing a virtual short**

Cutoff:

- **Current reduced to zero**
- **Ideal transistor behaves like an open switch**

* Note: There is also a mode of operation called inverse active, but it is rarely used.

Common-Base

Although the Common-Base configuration is not the most common biasing type, it is often helpful in the understanding of how the BJT works.

Emitter-Current Curves

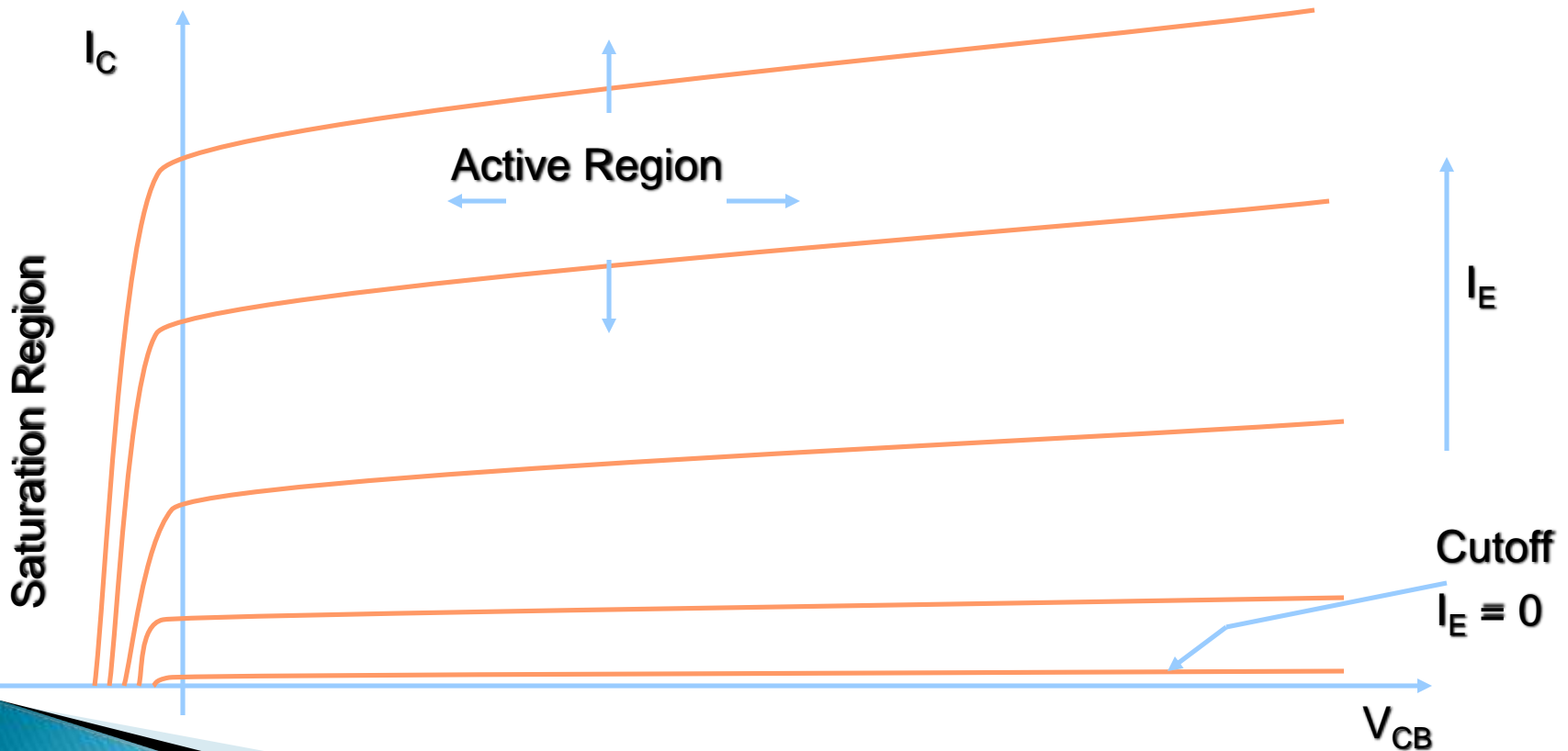

Common-Base

Circuit Diagram: NPN Transistor

The Table Below lists assumptions that can be made for the attributes of the common-base biased circuit in the different regions of operation. Given for a Silicon NPN transistor.

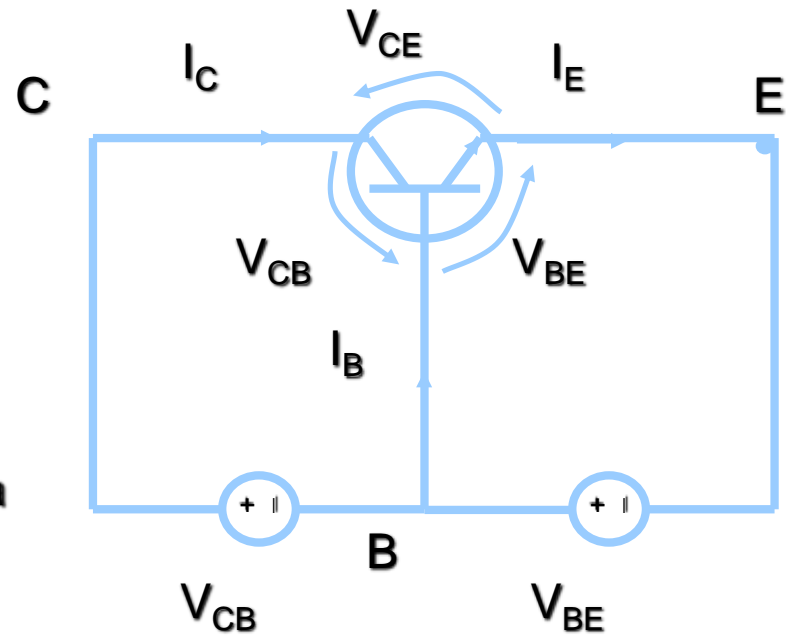

Region of Operation	I_C	V_{CE}	V_{BE}	V_{CB}	C-B Bias	E-B Bias
Active	βI_B	$=V_{BE} + V_{CE}$	$\sim 0.7V$	$0V$	Rev.	Fwd.
Saturation	Max	$\sim 0V$	$\sim 0.7V$	$-0.7V < V_{CE} < 0$	Fwd.	Fwd.
Cutoff	~ 0	$=V_{BE} + V_{CE}$	$0V$	$0V$	Rev.	None /Rev.

Common-Emitter

Circuit Diagram

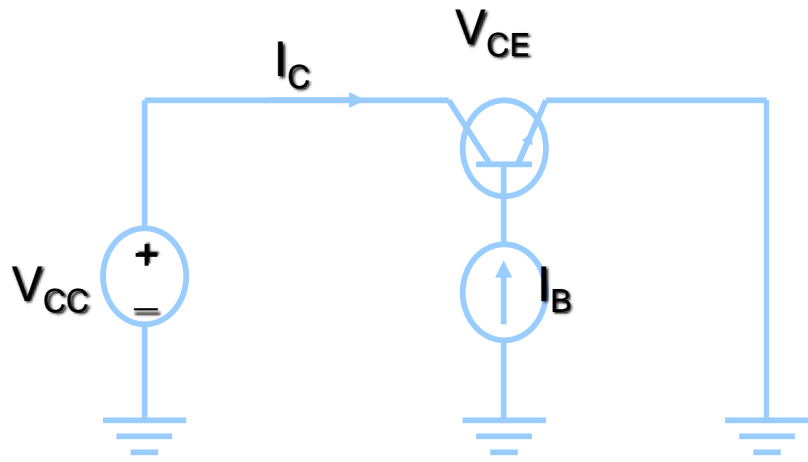

Collector-Current Curves

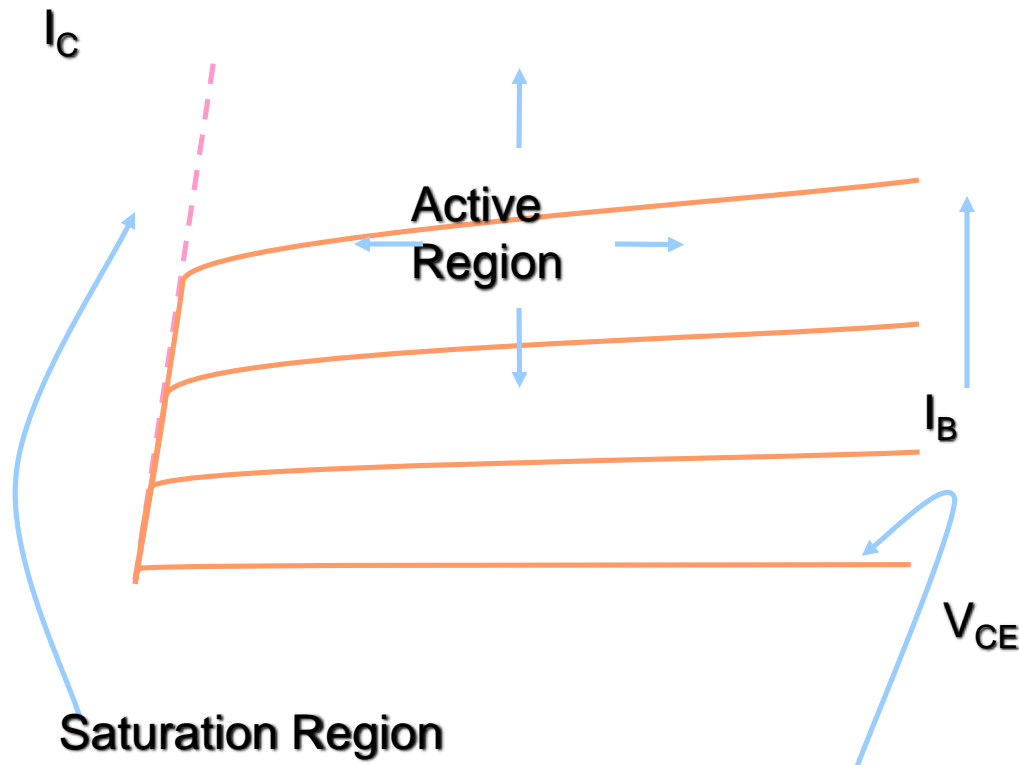

Region of Operation

Description

Active

Small base current controls a large collector current

Saturation

$V_{CE(sat)} \sim 0.2V$, V_{CE} increases with I_C

Cutoff

Achieved by reducing I_B to 0, Ideally, I_C will also equal 0

Cutoff Region
 $I_B = 0$

Common-Collector

Emitter-Current Curves

The Common-Collector biasing circuit is basically equivalent to the common-emitter biased circuit except instead of looking at I_C as a function of V_{CE} and I_B we are looking at I_E . Also, since $\alpha \sim 1$, and $\alpha \equiv I_C/I_E$ that means $I_C \sim I_E$

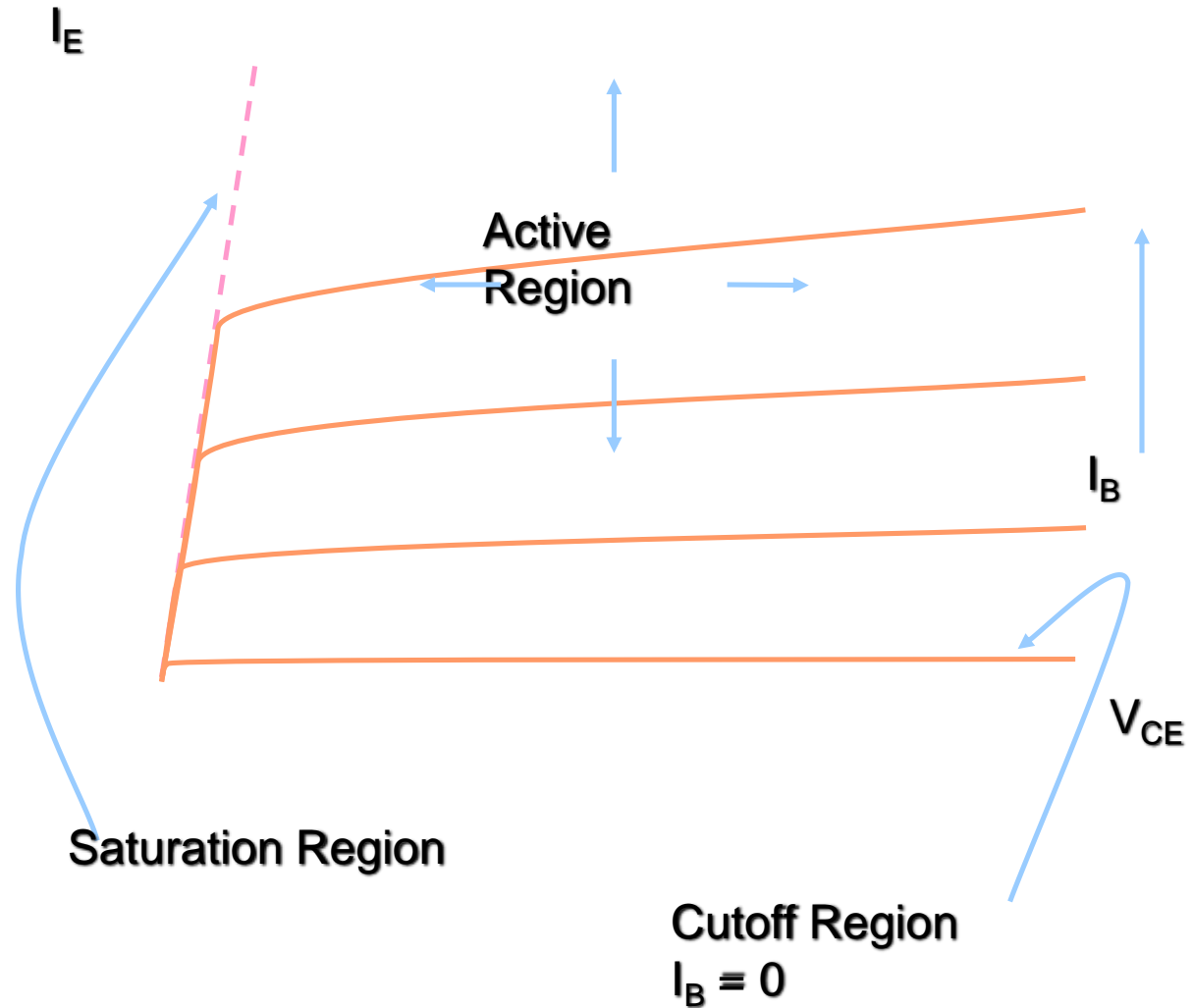

Eber-Moll BJT Model

The Eber-Moll Model for BJTs is fairly complex, but it is valid in all regions of BJT operation. The circuit diagram below shows all the components of the Eber-Moll Model:

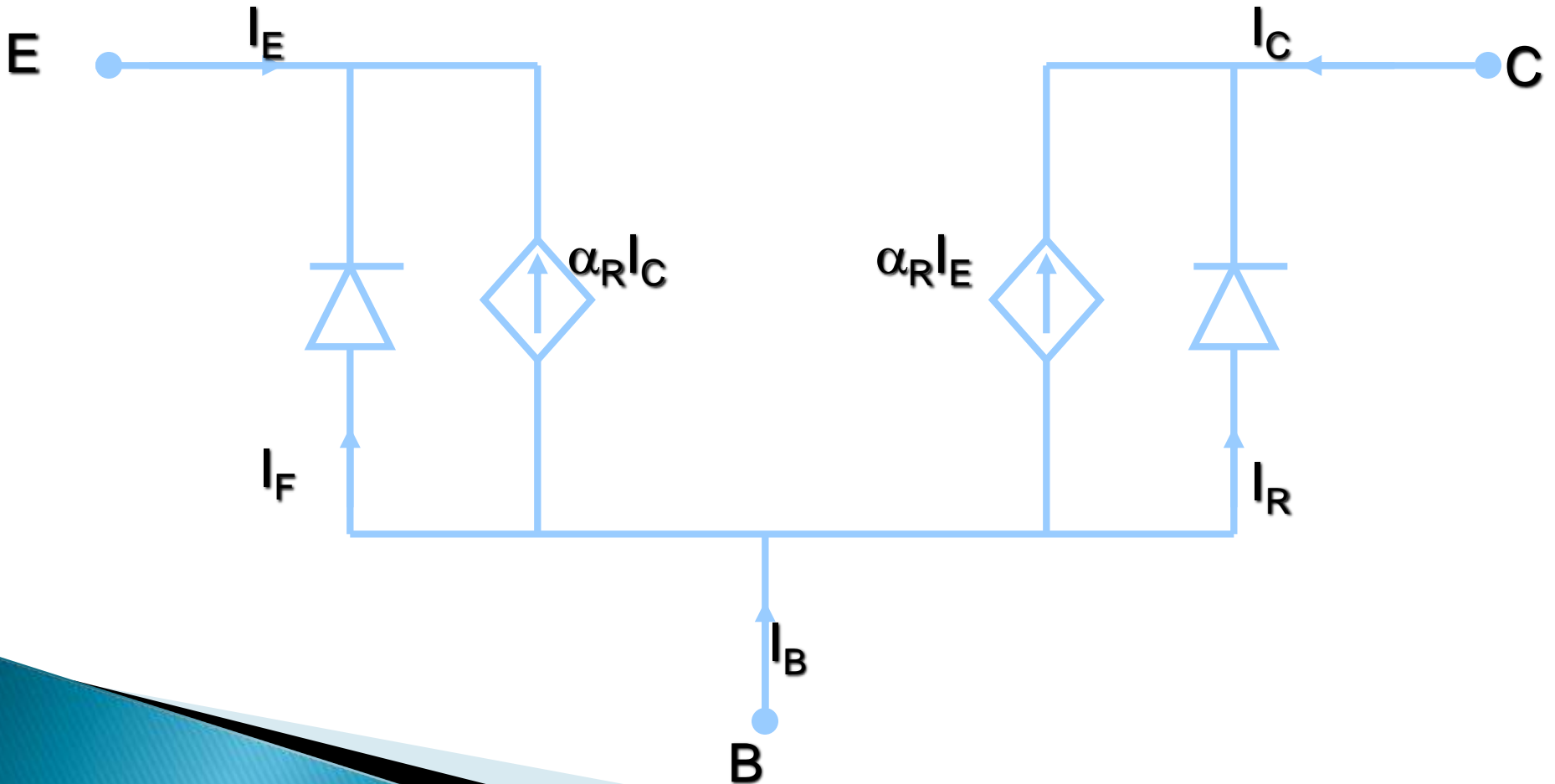

Eber-Moll BJT Model

α_R = Common-base current gain (in forward active mode)

α_F = Common-base current gain (in inverse active mode)

I_{ES} = Reverse-Saturation Current of B-E Junction

I_{CS} = Reverse-Saturation Current of B-C Junction

$$I_C = \alpha_F I_F - I_R \quad I_B = I_E - I_C$$

$$I_E = I_F - \alpha_R I_R$$

$$I_F = I_{ES} [\exp(qV_{BE}/kT) - 1] \quad I_R = I_{CS} [\exp(qV_{BC}/kT) - 1]$$

- ★ If I_{ES} & I_{CS} are not given, they can be determined using various BJT parameters.

Small Signal BJT Equivalent Circuit

The small-signal model can be used when the BJT is in the active region. The small-signal active-region model for a CB circuit is shown below:

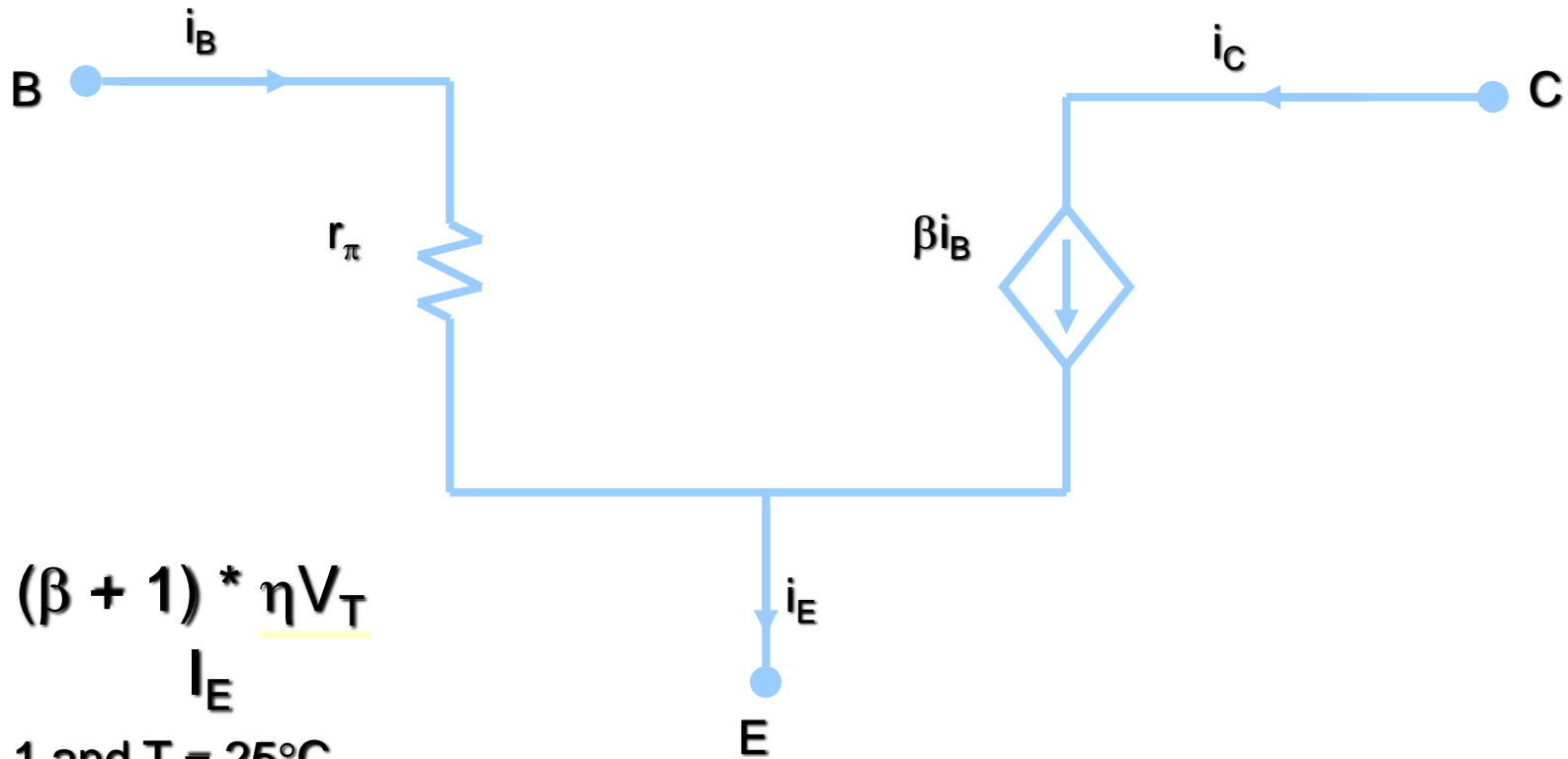

$$r_{\pi} = (\beta + 1) * \frac{\eta V_T}{I_E}$$

@ $\eta = 1$ and $T = 25^{\circ}\text{C}$

$$r_{\pi} = (\beta + 1) * \frac{0.026}{I_E}$$

Recall:

$$\beta = I_C / I_B$$

The Early Effect (Early Voltage)

Note: Common-Emitter Configuration

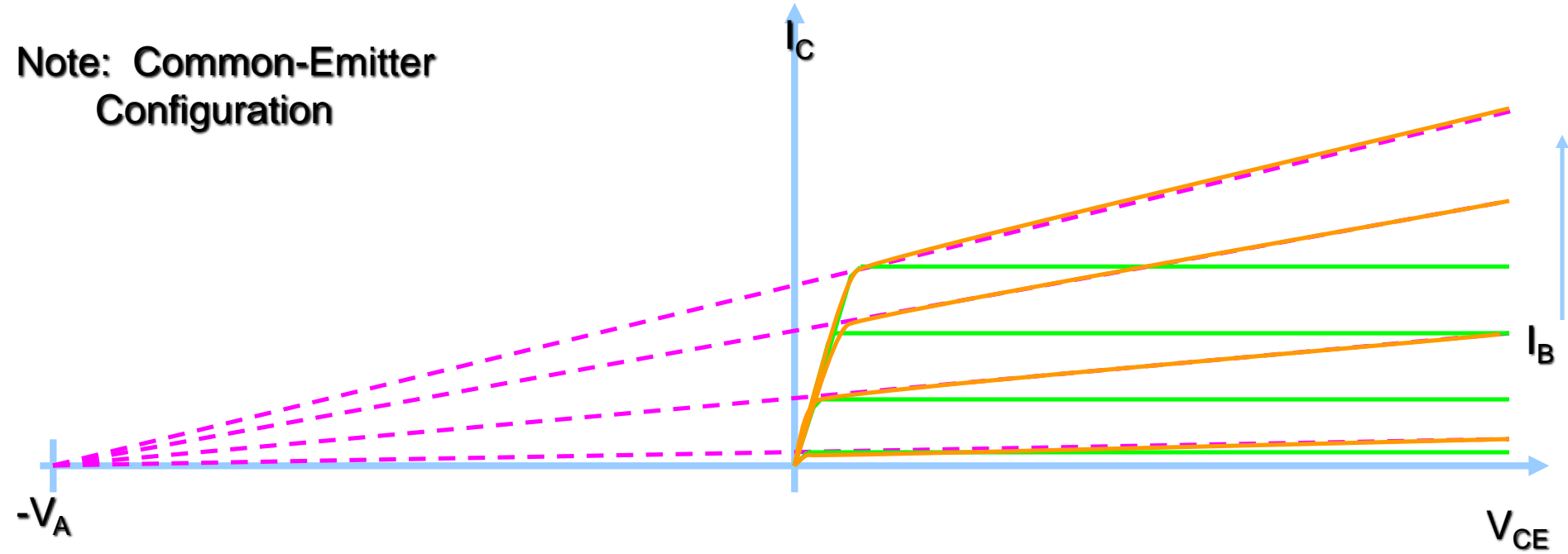

Green = Ideal I_C

Orange = Actual I_C (I_C')

$$I_C' = I_C \left(1 + \frac{V_{CE}}{V_A} \right)$$



Early Effect Example

Given: The common-emitter circuit below with $I_B = 25\mu\text{A}$, $V_{CC} = 15\text{V}$,
 $\beta = 100$ and $V_A = 80$.

Find: a) The ideal collector current
 b) The actual collector current

Circuit Diagram

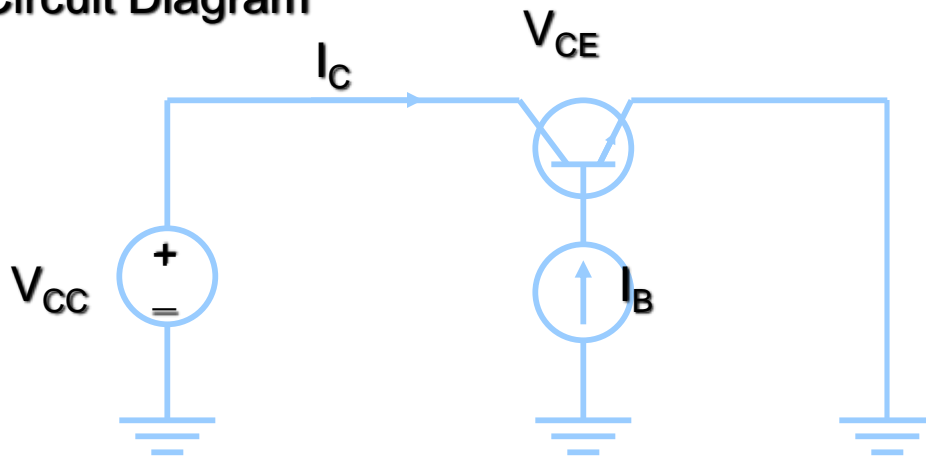

$$\beta = 100 = I_C / I_B$$

a)

$$I_C = 100 * I_B = 100 * (25 \times 10^{-6} \text{ A})$$

$$I_C = 2.5 \text{ mA}$$

$$b) \quad I_C' = I_C \left(\frac{V_{CE} + 1}{V_A} \right) = 2.5 \times 10^{-3} \left(\frac{15 + 1}{80} \right) = 2.96 \text{ mA}$$

$$I_C' = 2.96 \text{ mA}$$