

# **POWER POINT PRESENTATION ON CONTROL SYSTEMS**

**IV Semester (IARE-R16)**

**Prepared**

**By**

**Ms. P SRIDHAR, Professor**

**ELECTRICAL AND ELECTRONICS ENGINEERING  
INSTITUTE OF AERONAUTICAL ENGINEERING  
(AUTONOMOUS)**

**DUNDIGAL, HYDERABAD - 500043**

UNIT - I  
INTRODUCTION TO CONTROL  
SYSTEMS

# Introduction

**System** – An interconnection of elements and devices for a desired purpose.

**Control System** – An interconnection of components forming a system configuration that will provide a desired response.

**Process** – The device, plant, or system under control. The input and output relationship represents the cause-and-effect relationship of the process.



Process to be controlled.

# Chapter 1: Introduction to Control Systems

## Objectives

In this chapter we describe a general process for designing a control system.

A control system consisting of interconnected components is designed to achieve a desired purpose. To understand the purpose of a control system, it is useful to examine examples of control systems through the course of history. These early systems incorporated many of the same ideas of feedback that are in use today.

Modern control engineering practice includes the use of control design strategies for improving manufacturing processes, the efficiency of energy use, advanced automobile control, including rapid transit, among others.

We also discuss the notion of a design gap. The gap exists between the complex physical system under investigation and the model used in the control system synthesis.

The iterative nature of design allows us to handle the design gap effectively while accomplishing necessary tradeoffs in complexity, performance, and cost in order to meet the design specifications.

# Introduction

## Open-Loop Control Systems

utilize a controller or control actuator to obtain the desired response.



Open-loop control system (without feedback).

## Closed-Loop Control Systems

utilizes feedback to compare the actual output to the desired output response.

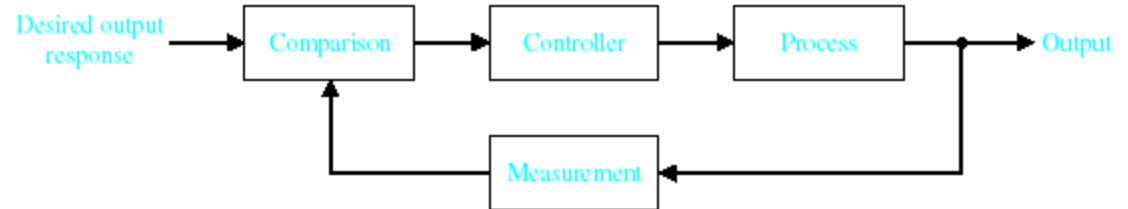

Closed-loop feedback control system (with feedback).

## Multivariable Control System

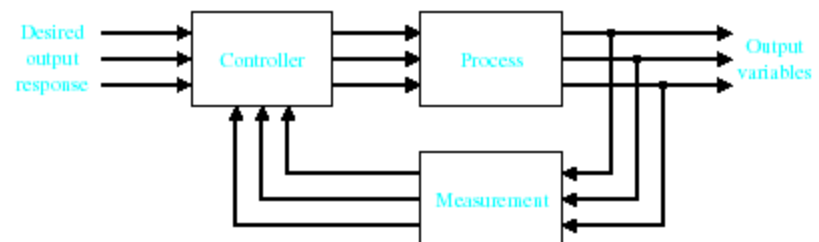

# History

Greece (BC) – Float regulator mechanism

Holland (16<sup>th</sup> Century)– Temperature regulator

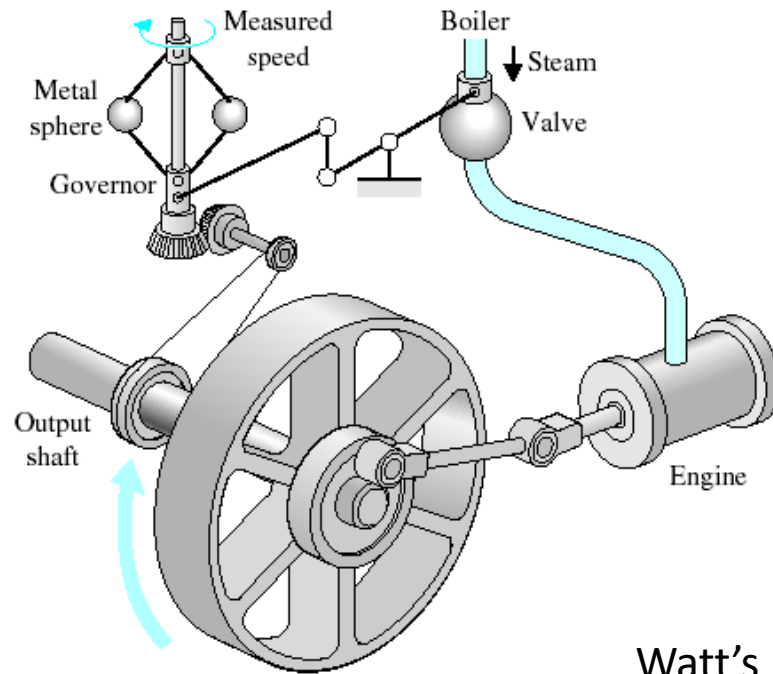

Watt's Flyball Governor  
(18<sup>th</sup> century)

# History

Water-level float regulator

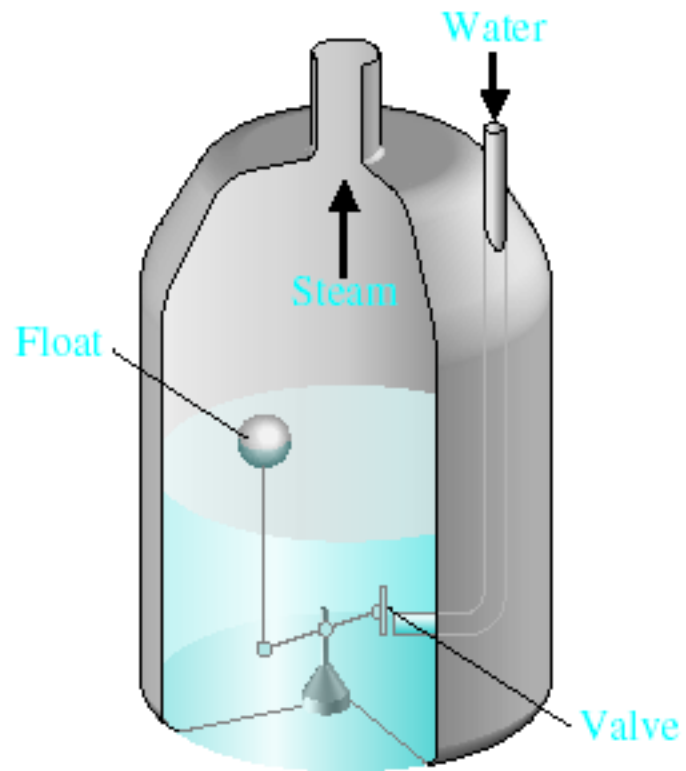

# History

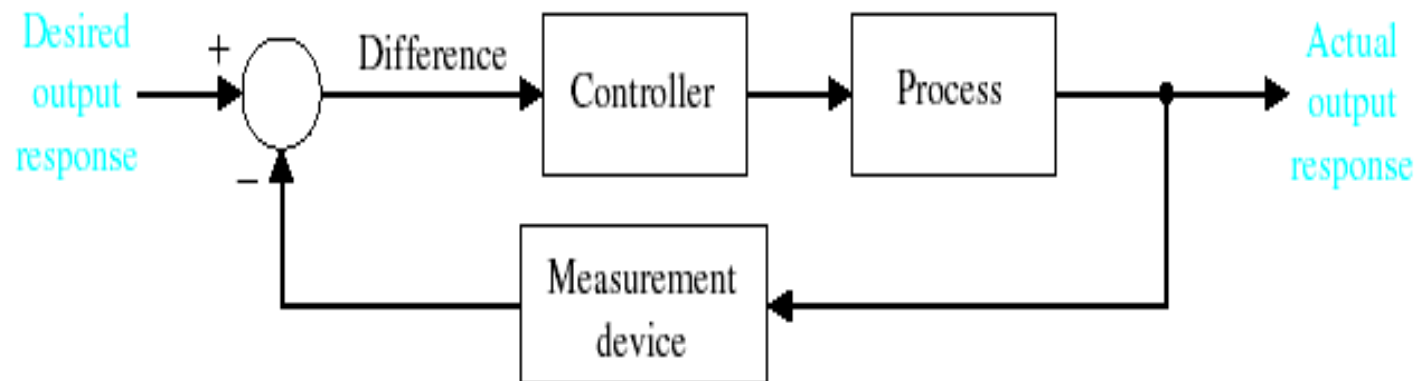

Closed-loop feedback system.



# History

**18th Century** James Watt's centrifugal governor for the speed control of a steam engine.

**1920s** Minorsky worked on automatic controllers for steering ships.

**1930s** Nyquist developed a method for analyzing the stability of controlled systems

**1940s** Frequency response methods made it possible to design linear closed-loop control systems

**1950s** Root-locus method due to Evans was fully developed

**1960s** State space methods, optimal control, adaptive control and

**1980s** Learning controls are begun to investigated and developed.

**Present** and on-going research fields. Recent application of modern control theory includes such non-engineering systems such as biological, biomedical, economic and socio-economic systems

??

# Examples of Modern Control Systems

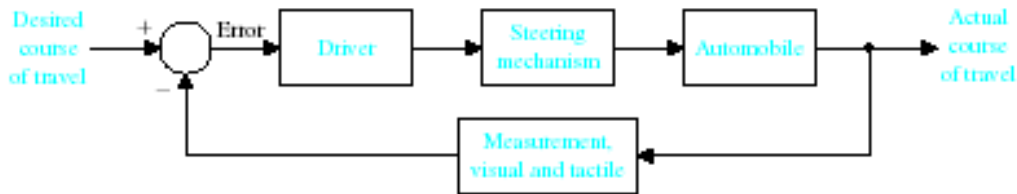

(a)

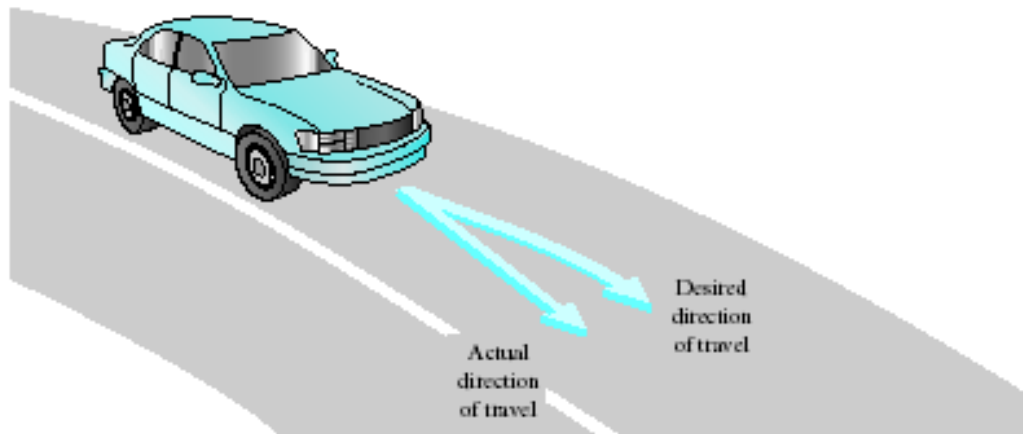

(b)

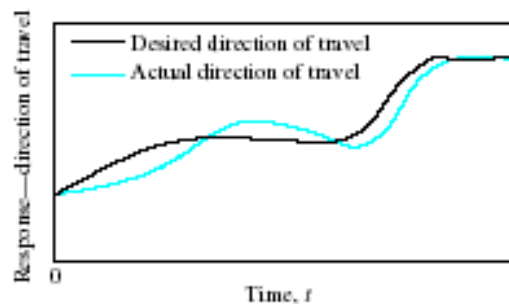

(c)

(a) Automobile steering control system.

(b) The driver uses the difference between the actual and the desired direction of travel

to generate a controlled adjustment of the steering wheel.

(c) Typical direction-of-travel response.

# Examples of Modern Control Systems

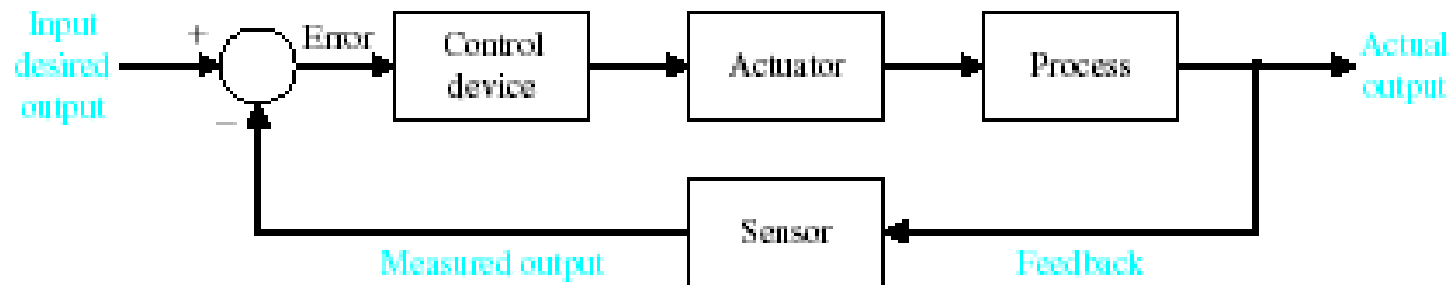

A negative feedback system block diagram depicting a basic closed-loop control system.  
The control device is often called a "controller."

# Examples of Modern Control Systems

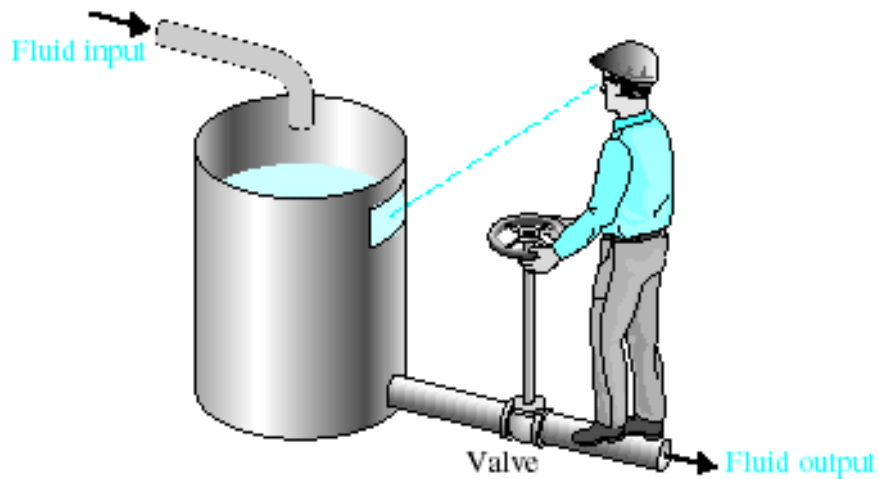

A manual control system for regulating the level of fluid in a tank by adjusting the output valve. The operator views the level of fluid through a port in the side of the tank.

# Examples of Modern Control Systems

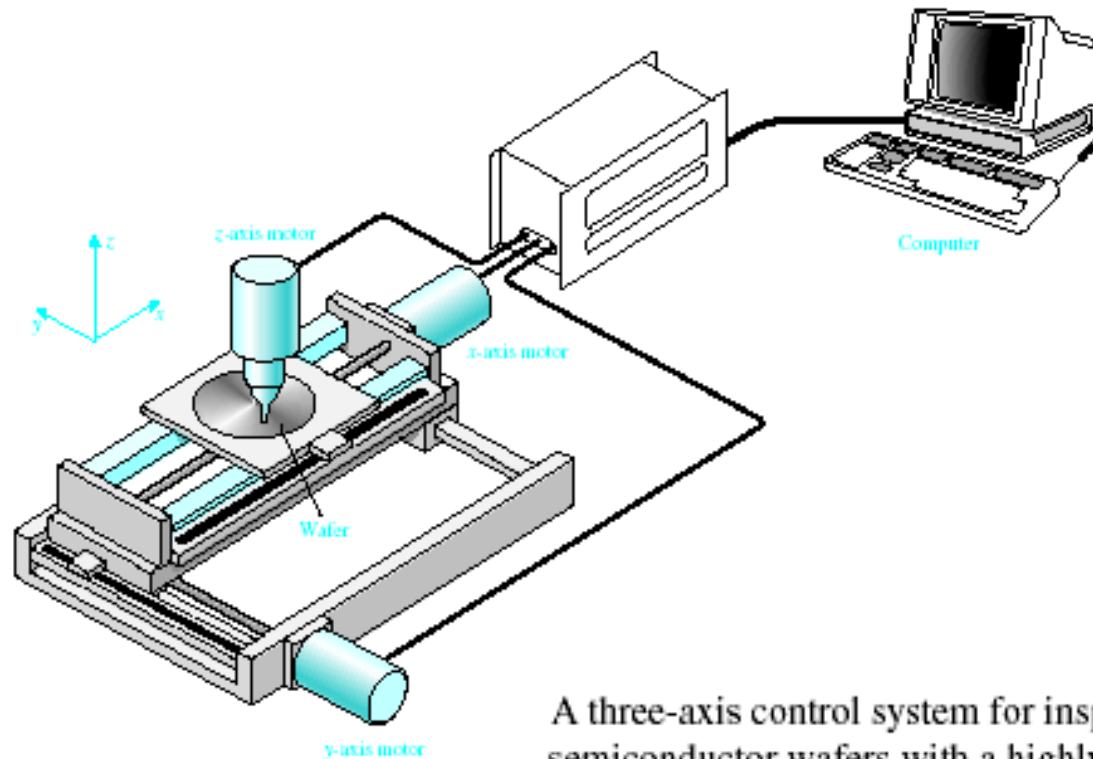

A three-axis control system for inspecting individual semiconductor wafers with a highly sensitive camera.

# Examples of Modern Control Systems

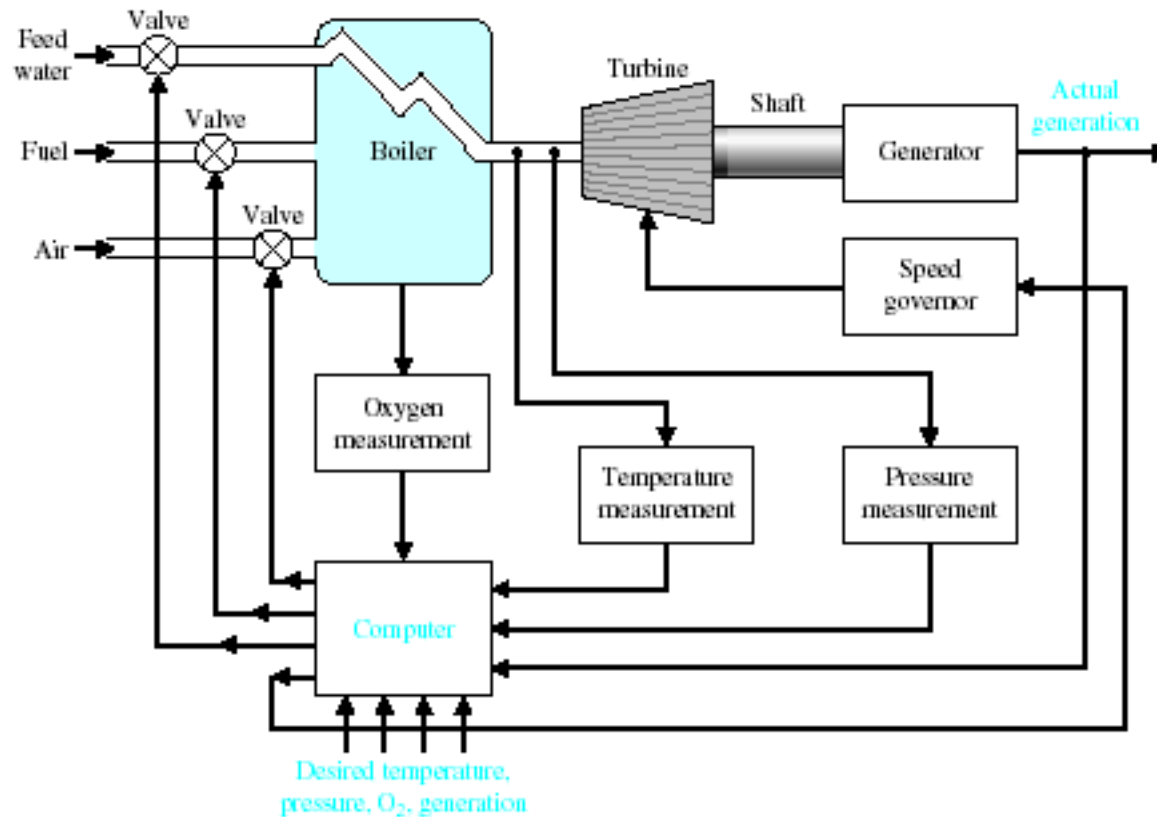

Coordinated control system for a boiler-generator.

# Examples of Modern Control Systems

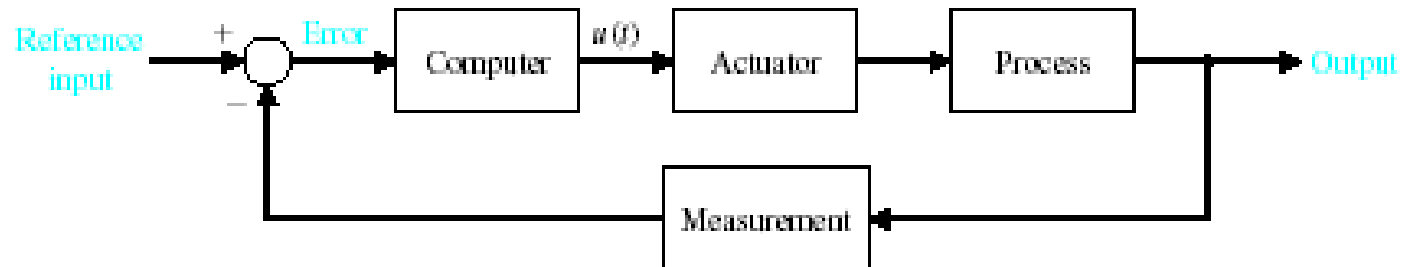

A computer control system.

# Examples of Modern Control Systems

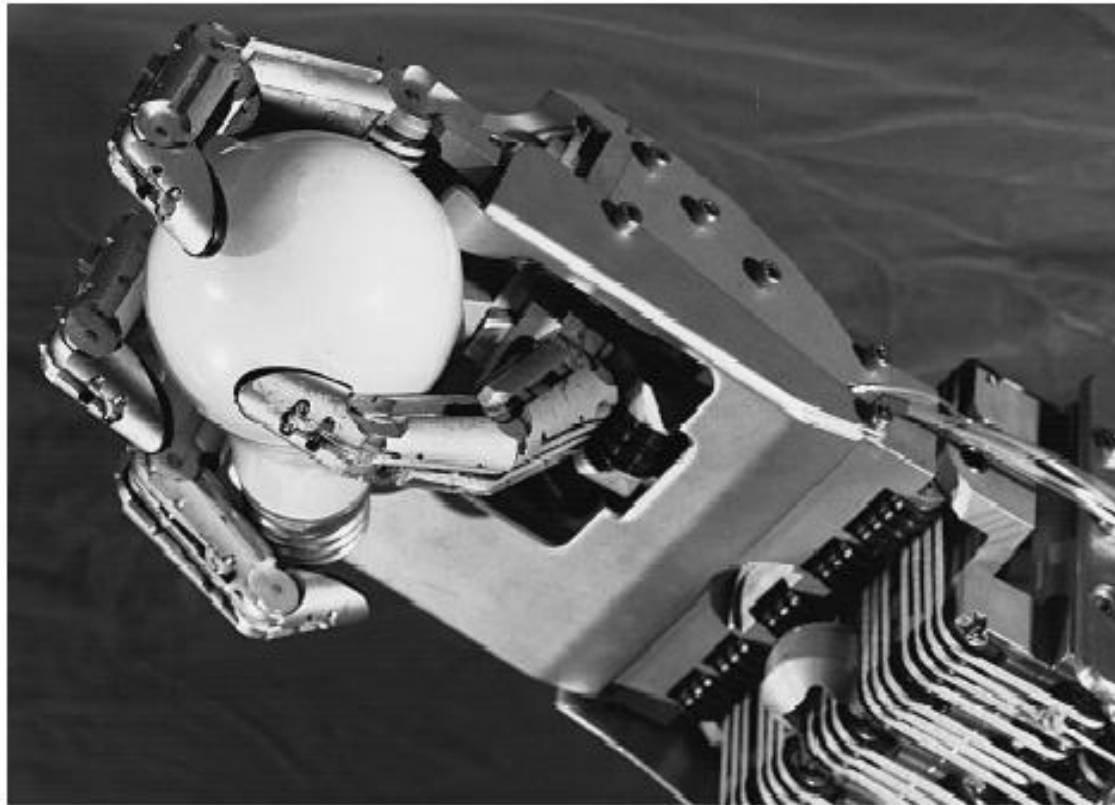

The Utah/MIT Dextrous Robotic Hand: A dextrous robotic hand having 18 degrees of freedom, developed as a research tool by the Center for Engineering Design at the University of Utah and the Artificial Intelligence Laboratory at MIT. It is controlled by five Motorola 68000 microprocessors and actuated by 36 high-performance electropneumatic actuators via high-strength polymeric tendons. The hand has three fingers and a thumb. It uses touch sensors and tendons for control.  
(Photograph by Michael Milochik. Courtesy of University of Utah.)



# Examples of Modern Control Systems

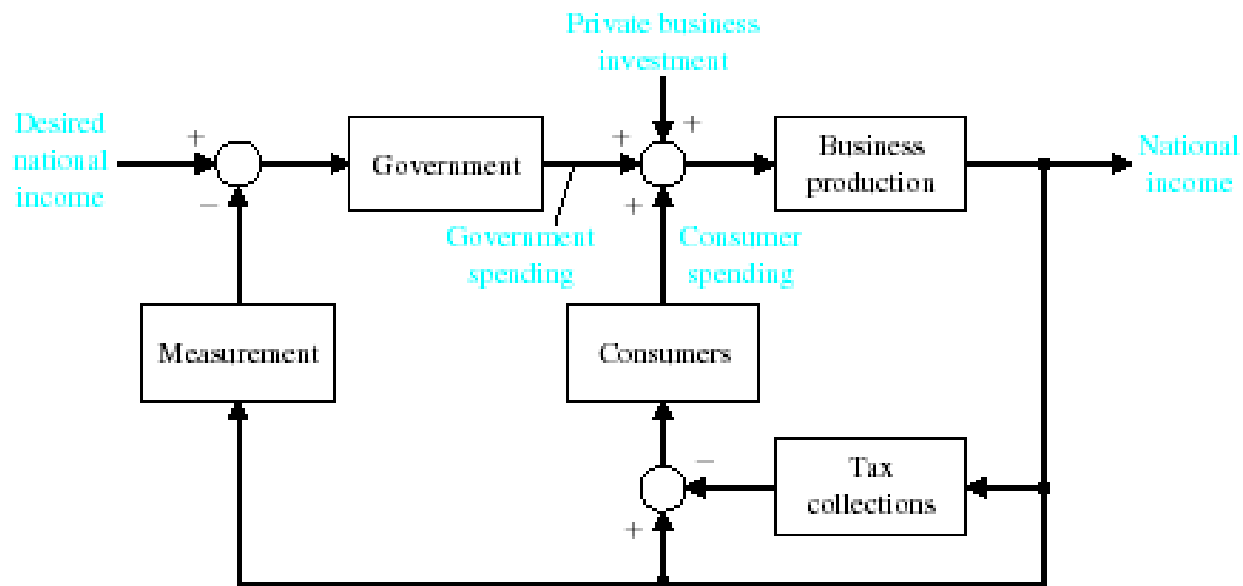

A feedback control system model of the national income.

# Examples of Modern Control Systems

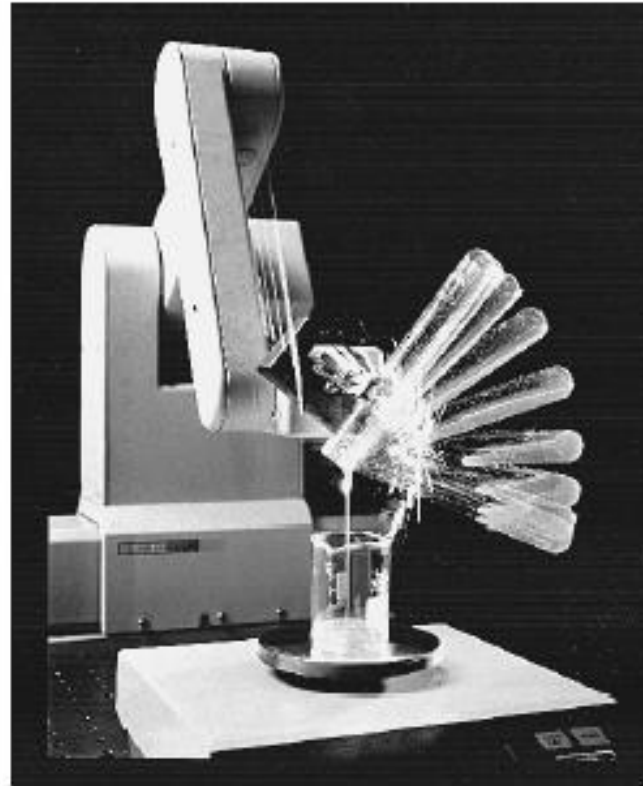

A laboratory robot used for sample preparation. The robot manipulates small objects, such as test tubes, and probes in and out of tight places at relatively high speeds [41].  
(© Copyright 1993 Hewlett-Packard Company. Reproduced with permission.)

# The Future of Control Systems

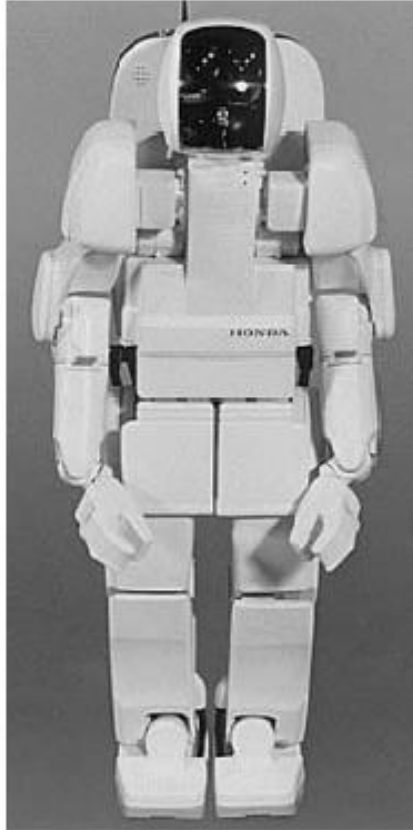

The Honda P3 humanoid robot. P3 walks, climbs stairs and turns corners.  
Photo courtesy of American Honda Motor, Inc.

# The Future of Control Systems

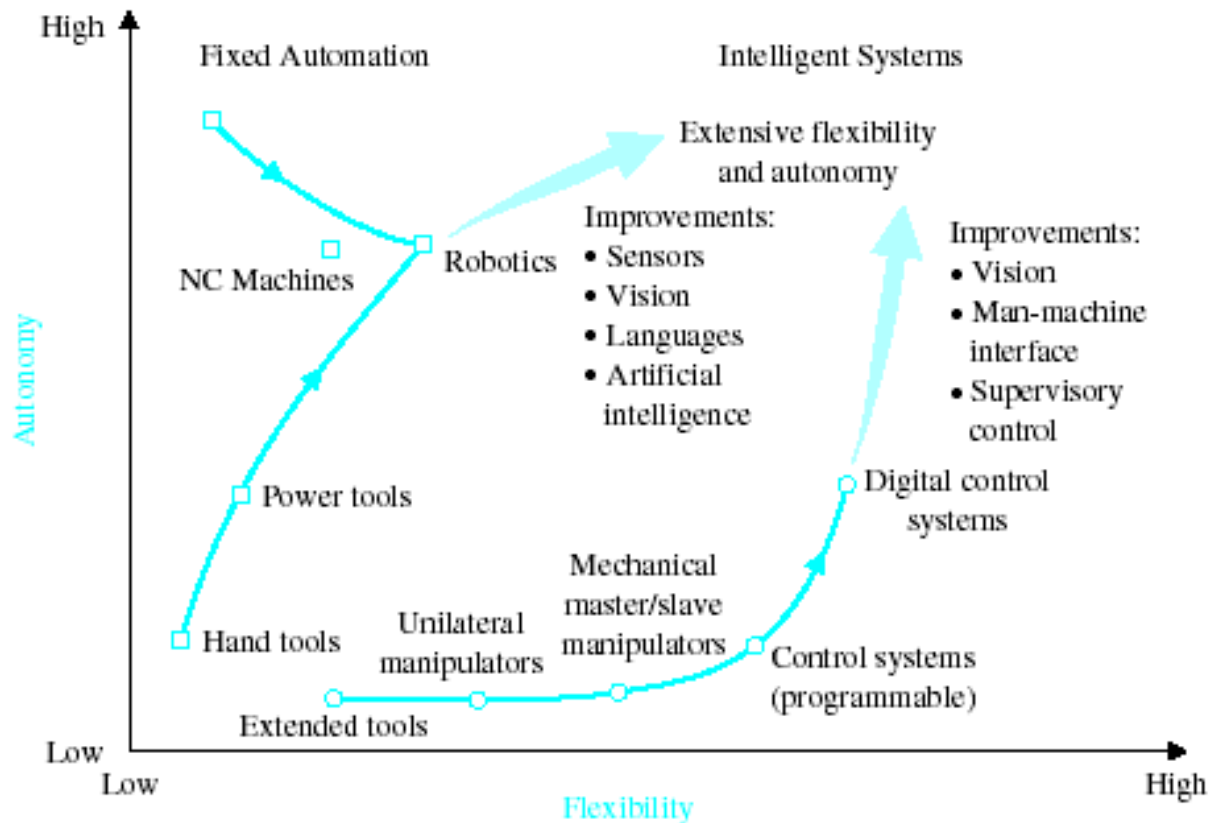

Future evolution of control systems and robotics.

# Control System Design

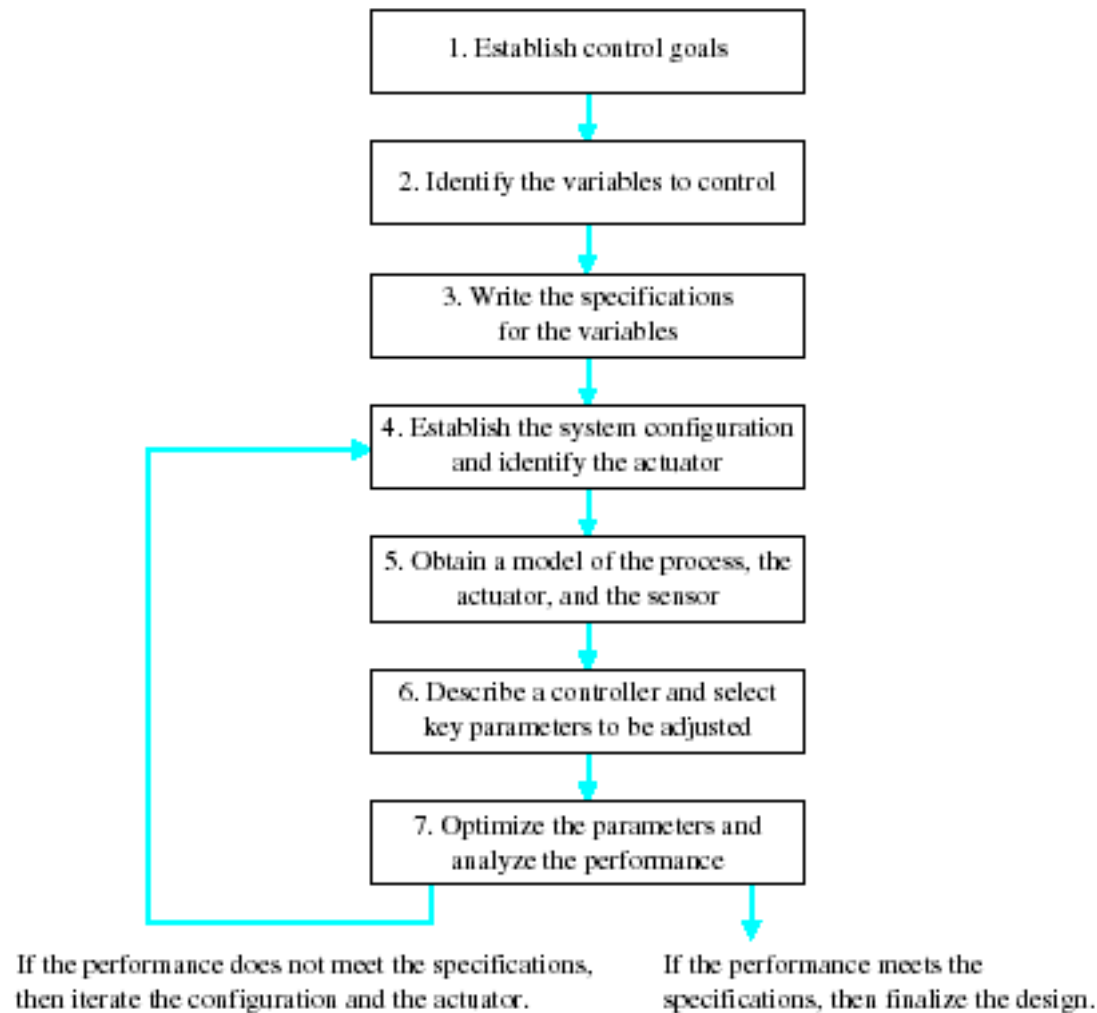

The control system design process.

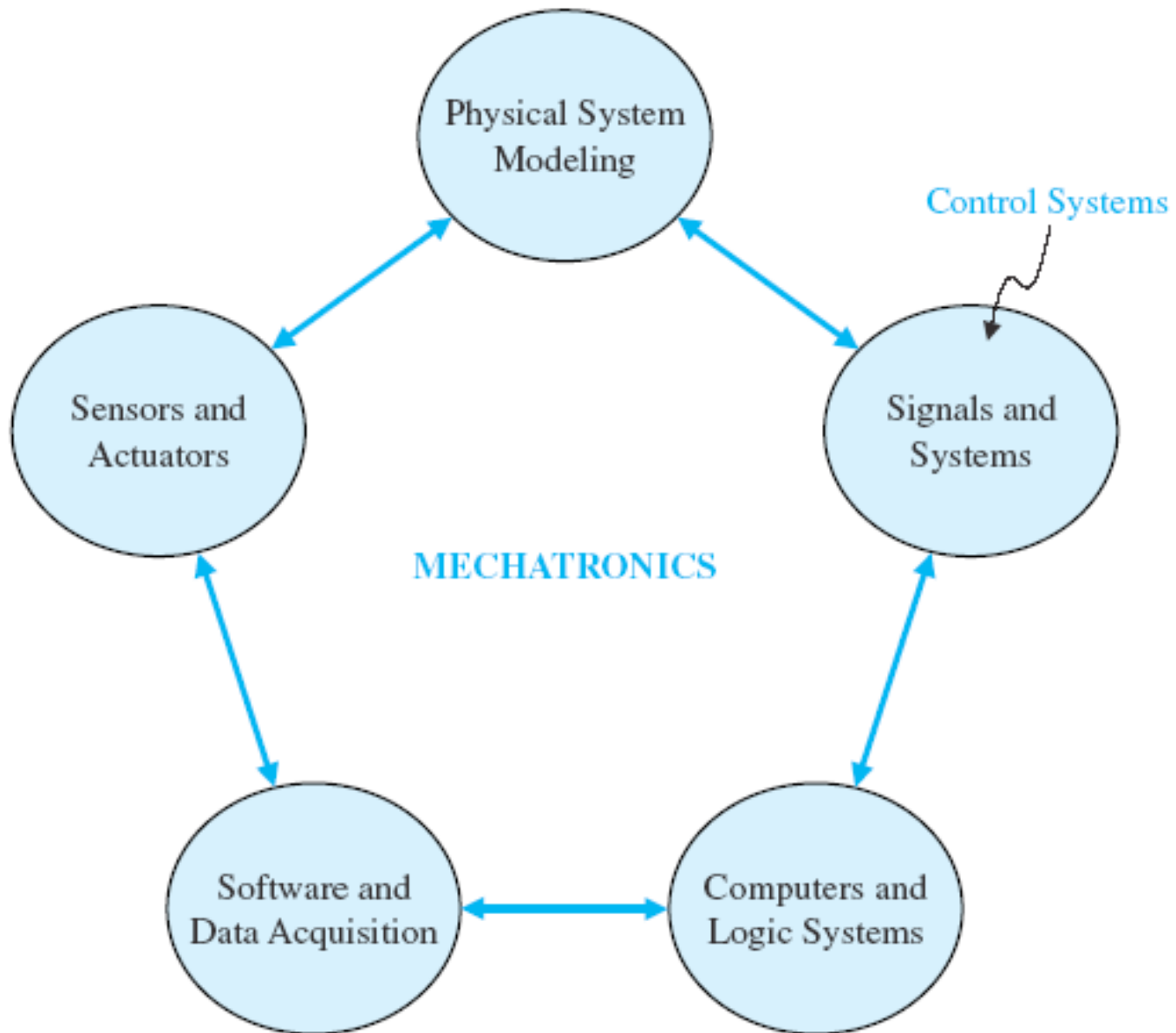

# Design Example

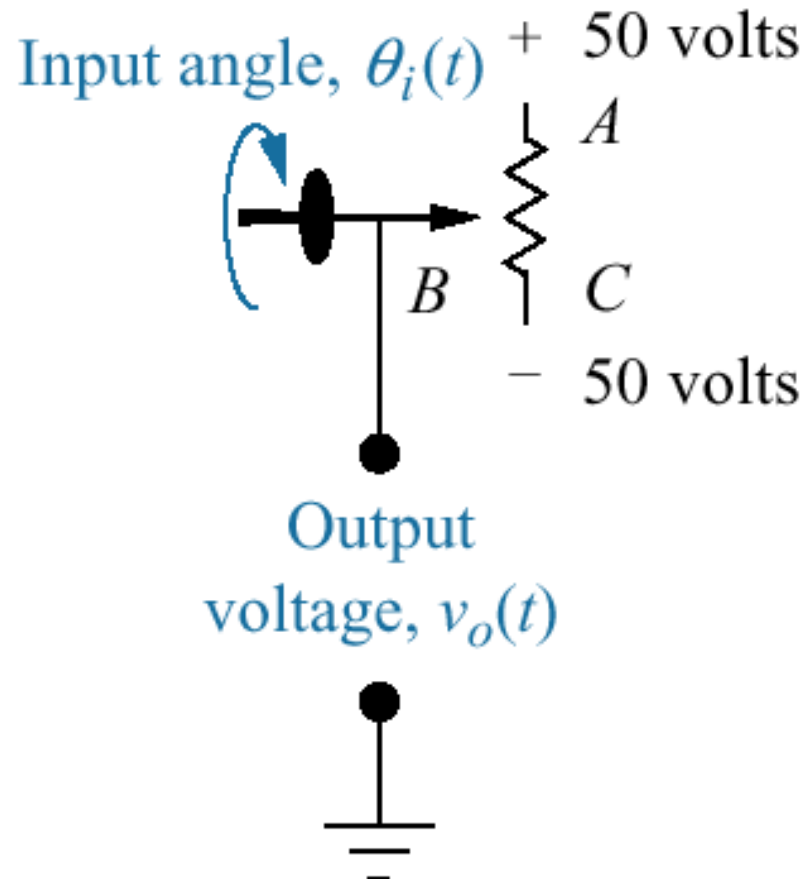

# Design Example

## ELECTRIC SHIP CONCEPT

### Vision

**Integrated Power System**

- ◆ Electric Drive
- ◆ Reduce # of Prime Movers
- ◆ Fuel savings
- ◆ Reduced maintenance

**All Electric Ship**

- ◆ Reduced manning
- ◆ Automation
- ◆ Eliminate auxiliary systems (steam, hydraulics, compressed air)

**Electrically Reconfigurable Ship**

- ◆ Technology Insertion
- ◆ Warfighting Capabilities

**Increasing Affordability and Military Capability**

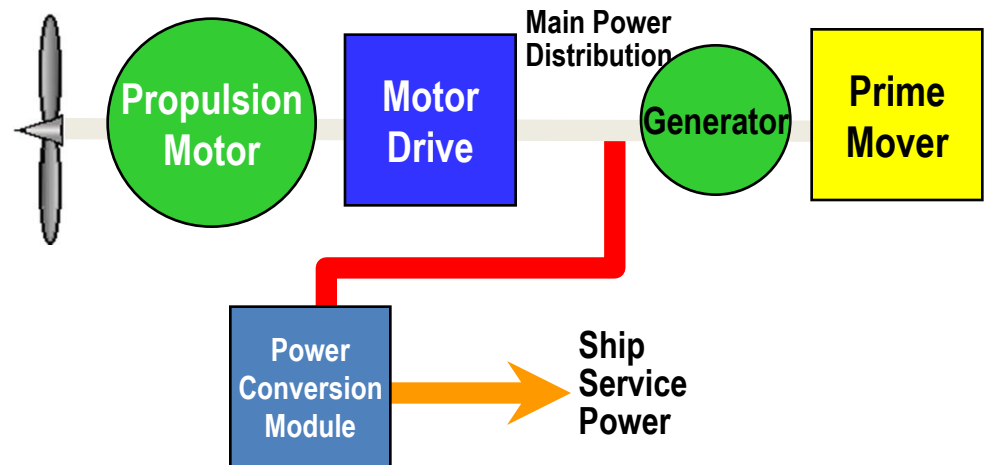



# Design Example

CVN(X) FUTURE AIRCRAFT CARRIER

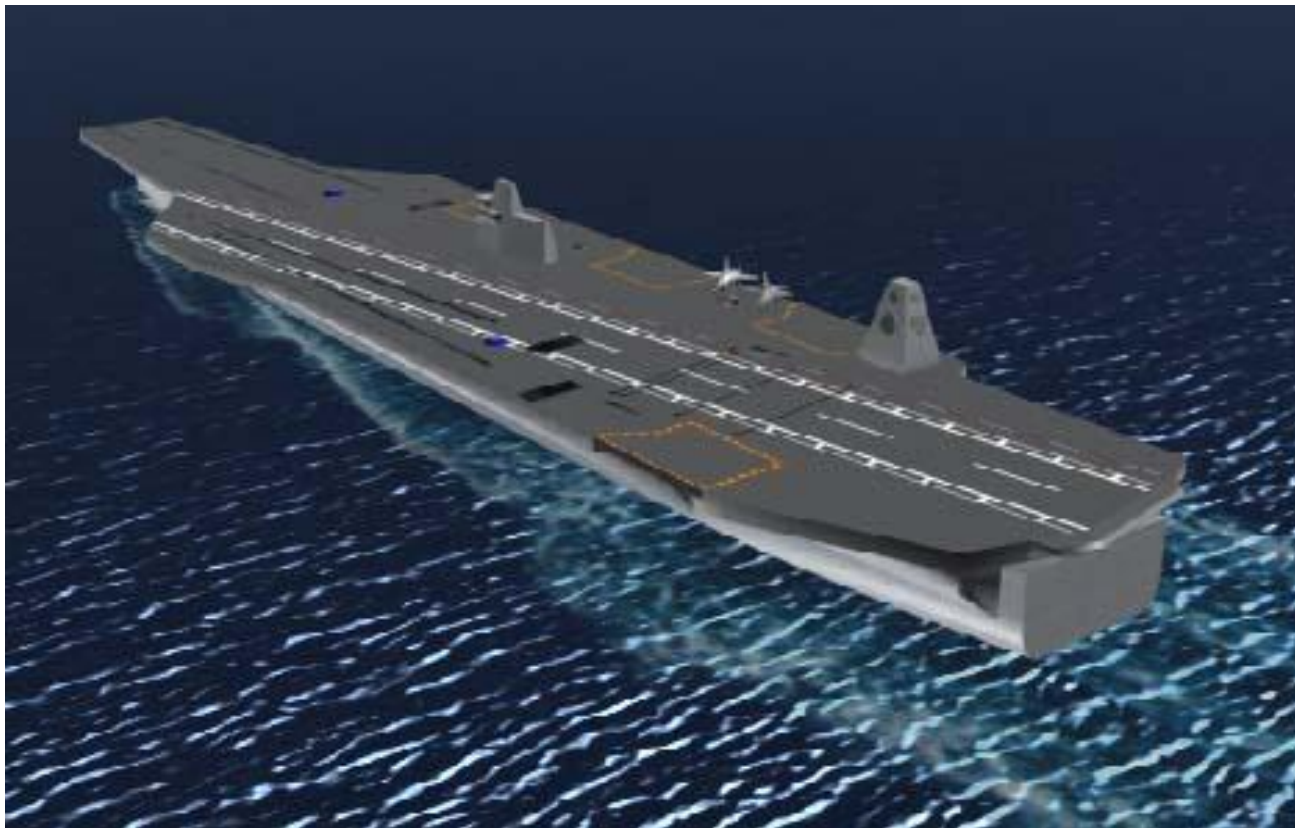

# Design Example

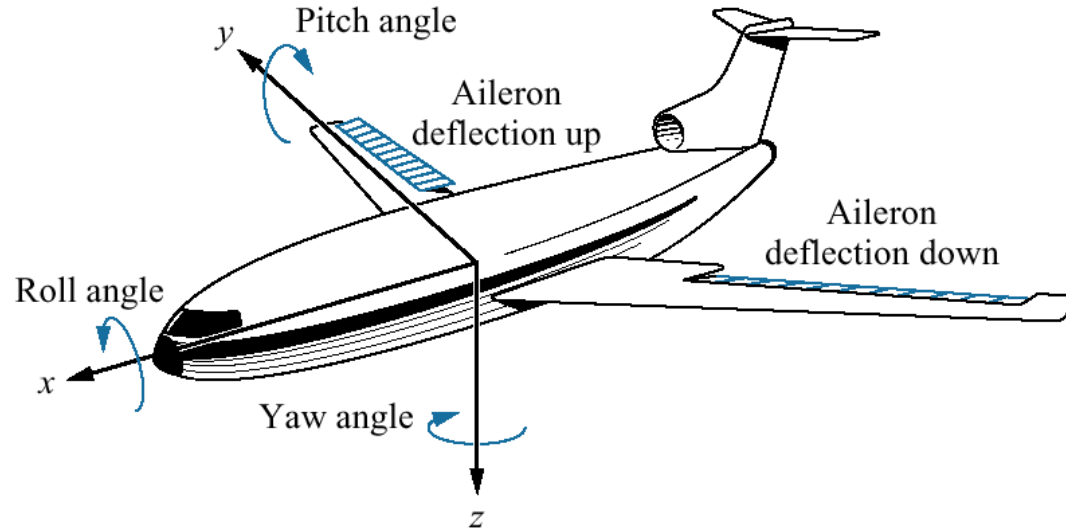

# Design Example

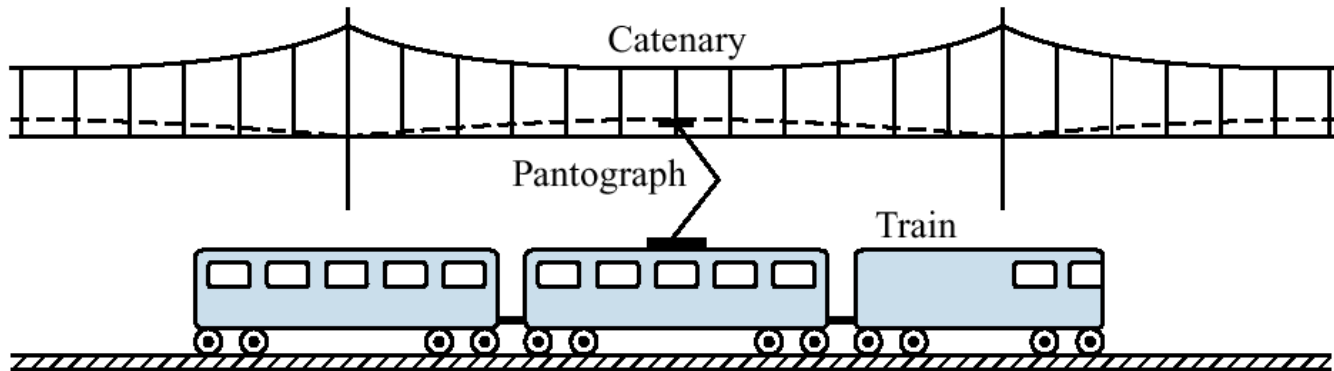
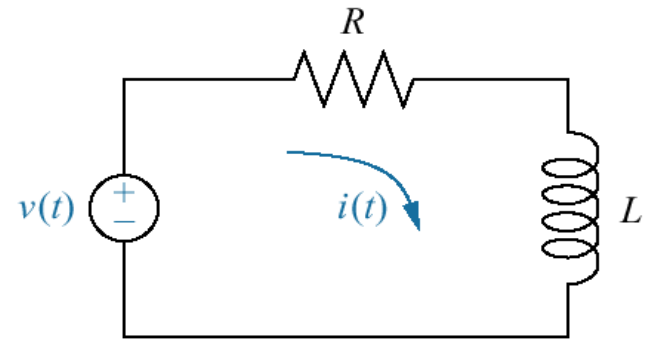

# Design Example

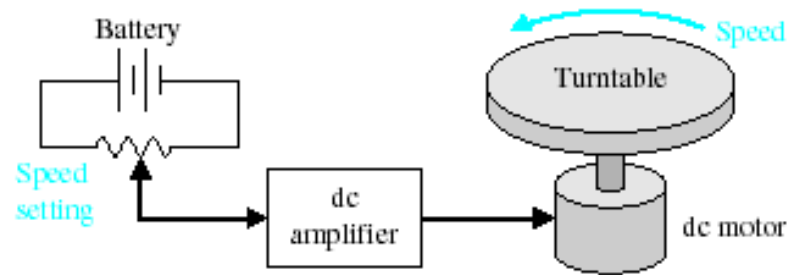

(a)

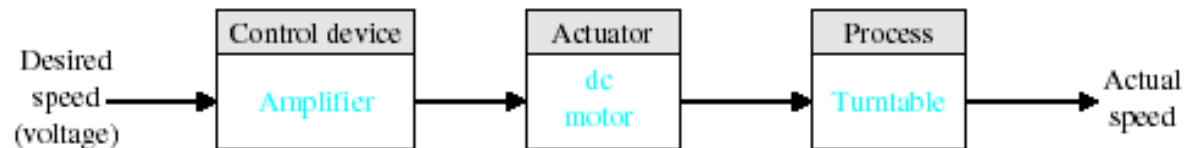

(b)

(a) Open-loop (without feedback) control of the speed of a turntable.

(b) Block diagram model.

# Design Example

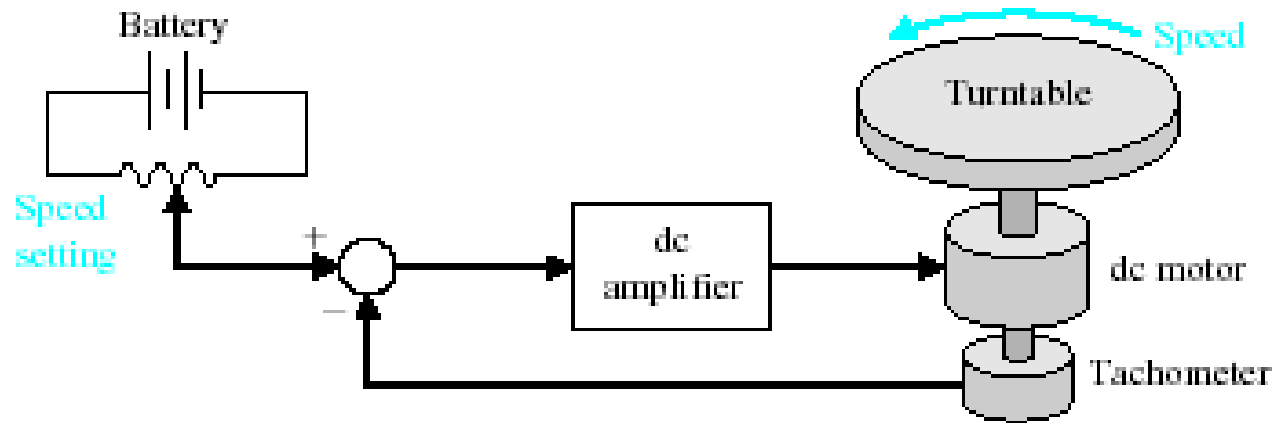

(a)

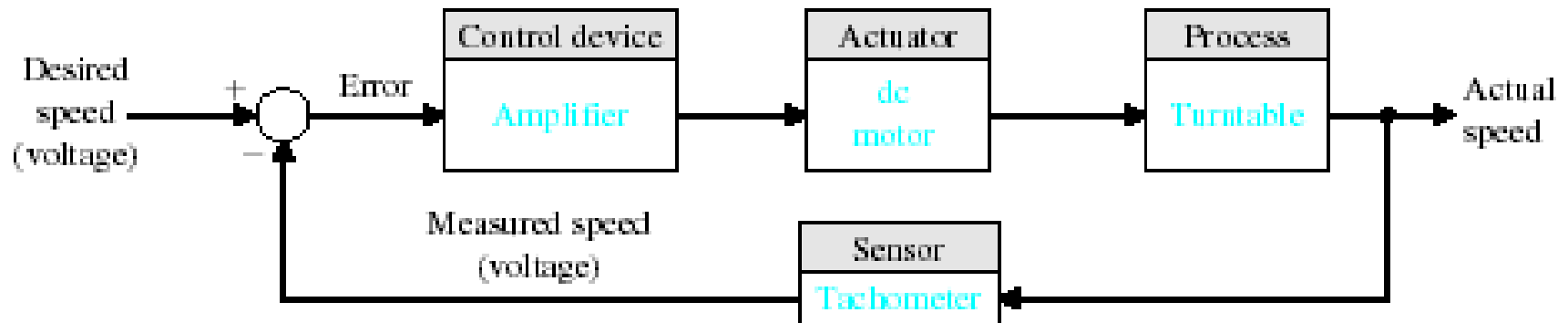

(b)

(a) Closed-loop control of the speed of a turntable.

(b) Block diagram model.

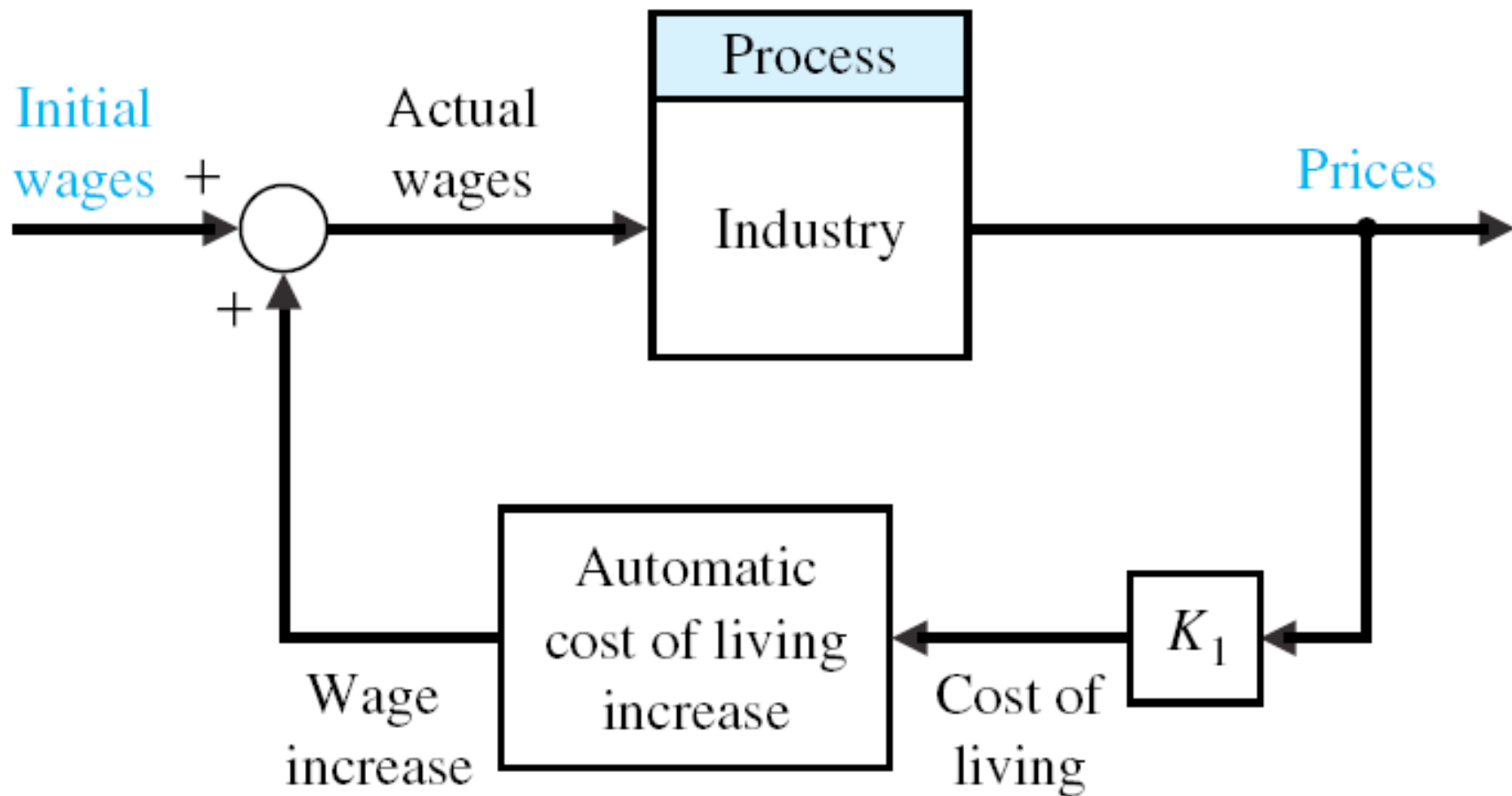

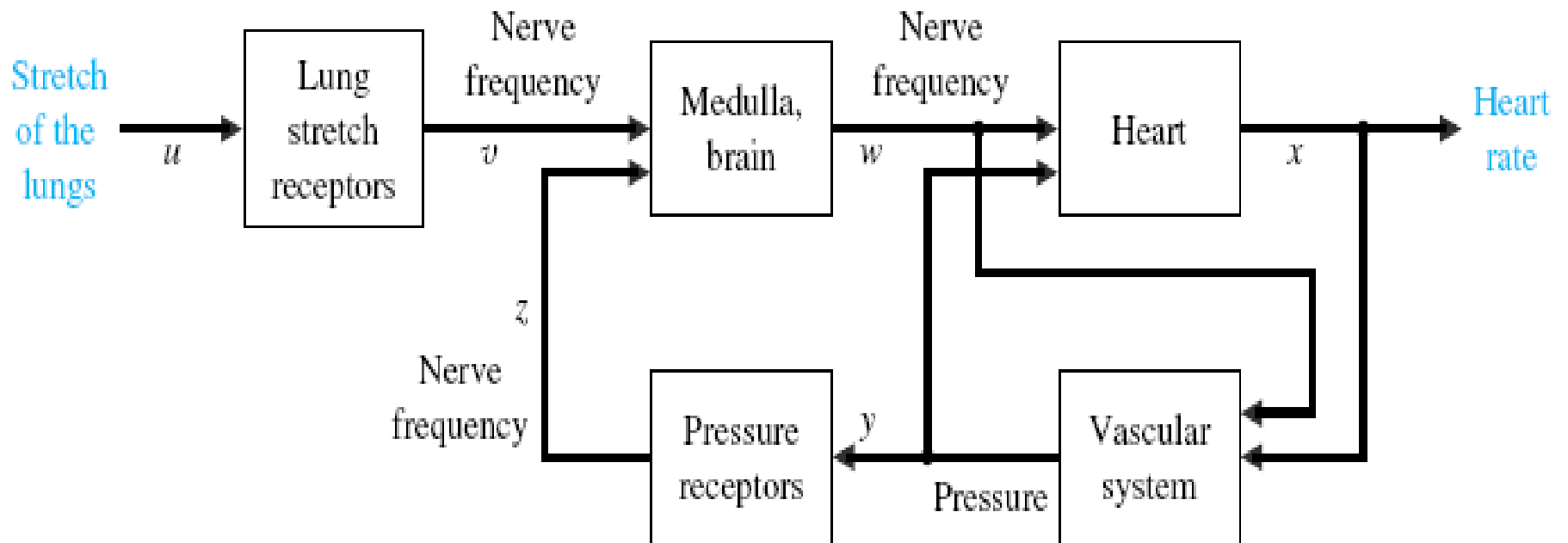

# Design Example

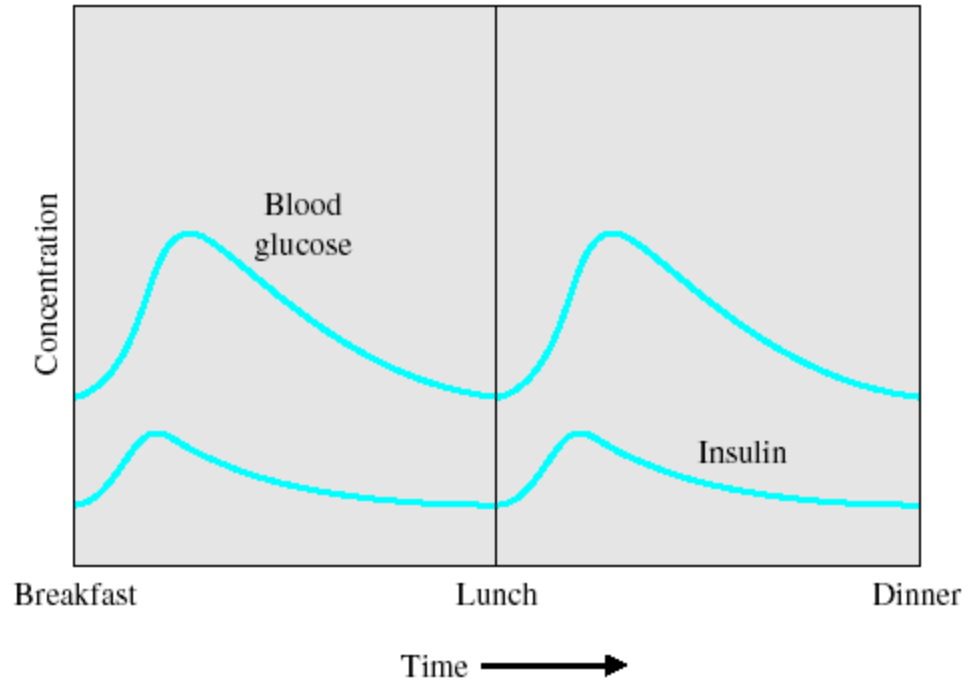

The blood glucose and insulin levels for a healthy person.



# Design Example

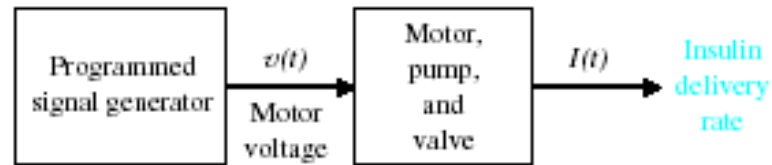

(a)

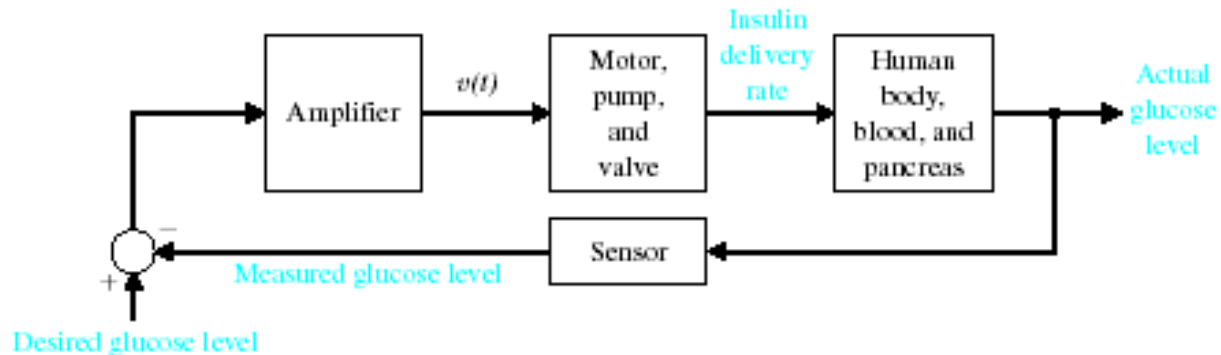

(b)

(a) Open-loop (without feedback) control and  
(b) closed-loop control of blood glucose.

# Sequential Design Example



(a)

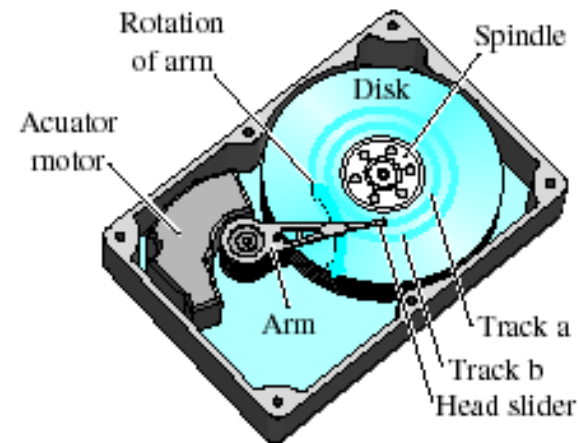

(b)

(a) A disk drive ©1999 Quantum Corporation. All rights reserved.

(b) Diagram of a disk drive.

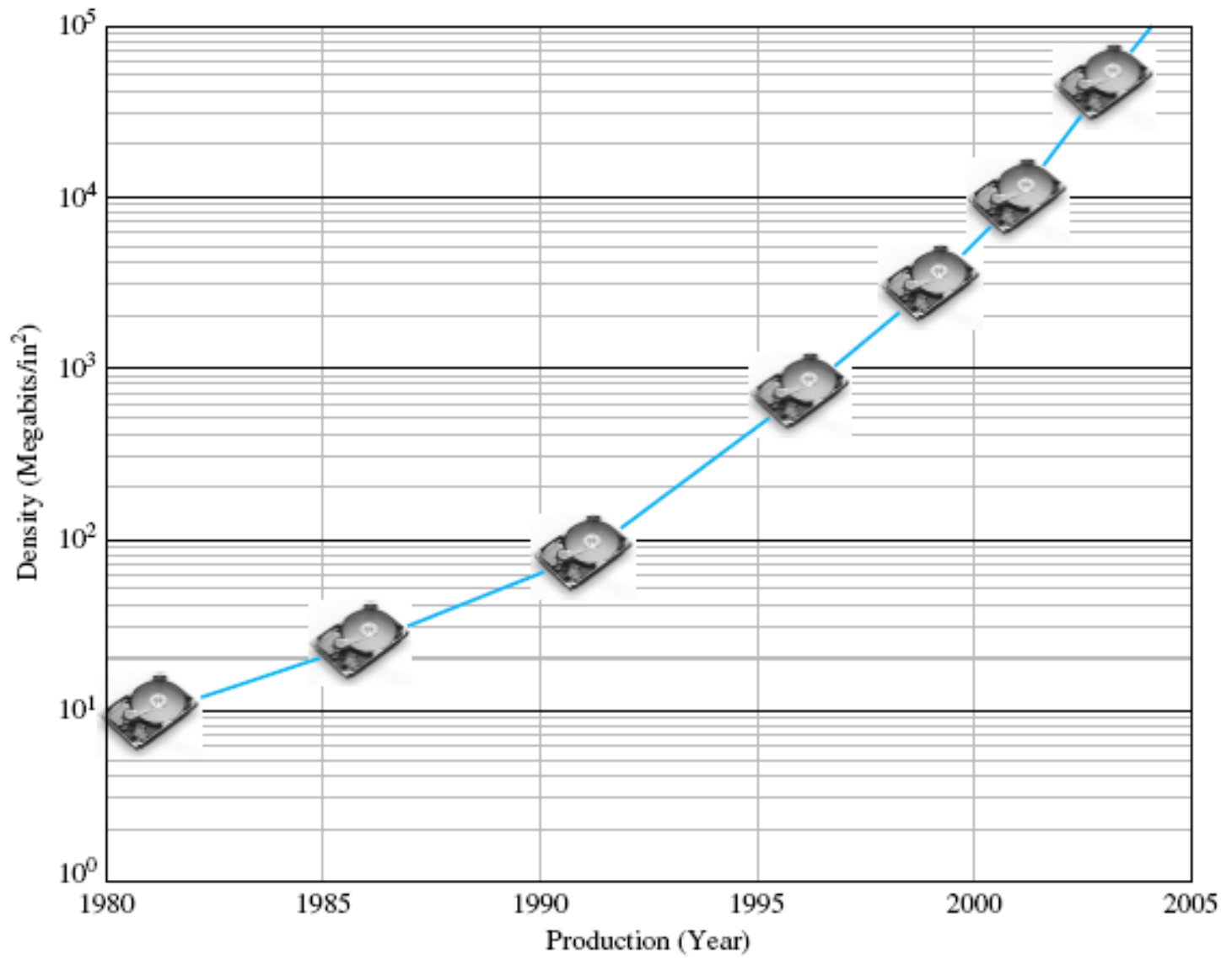

# Sequential Design Example

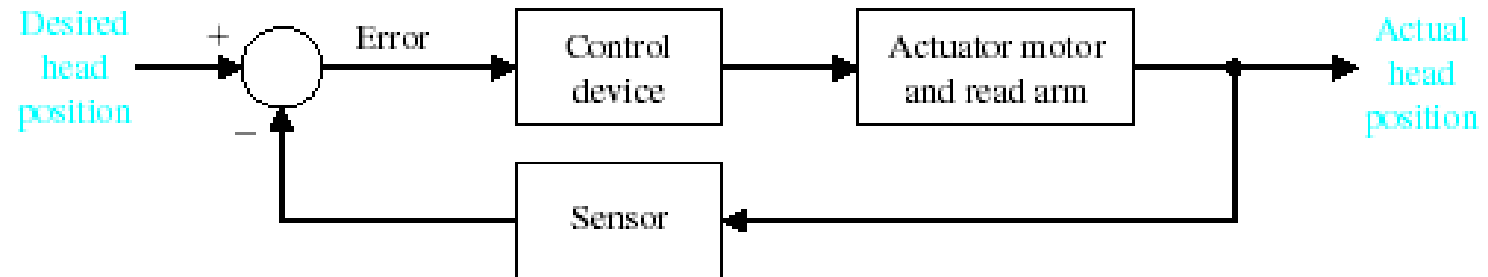

Closed-loop control system for disk drive.

# UNIT -III

## BLOCK DIAGRAM REDUCTION OF MULTIPLE SYSTEMS

# Figure 5.2

Components of a block diagram for a linear, time-invariant system

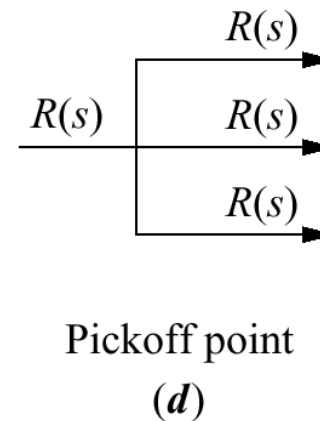
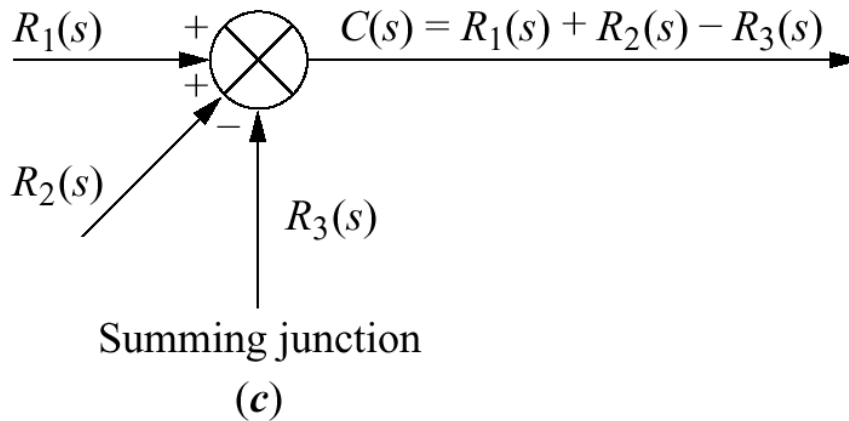
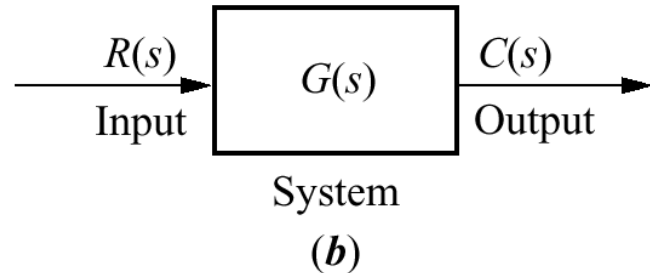
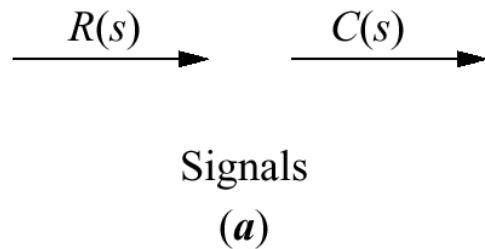

## Figure 5.3

- a. Cascaded subsystems;
- b. equivalent transfer function

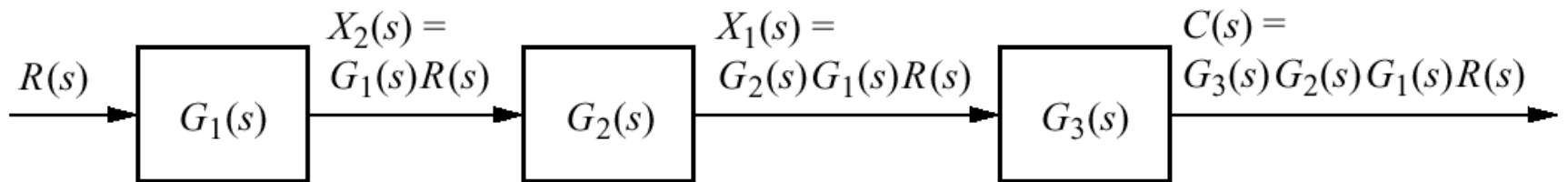

(a)

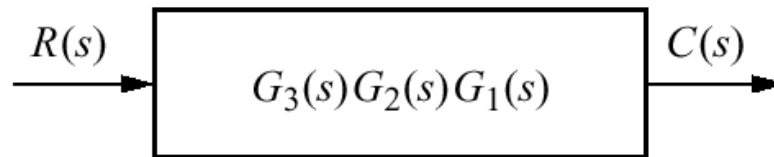

(b)

**Figure 5.5**

- a.** Parallel subsystems;
- b.** equivalent transfer function

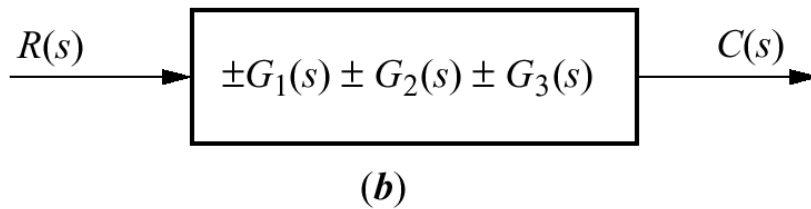
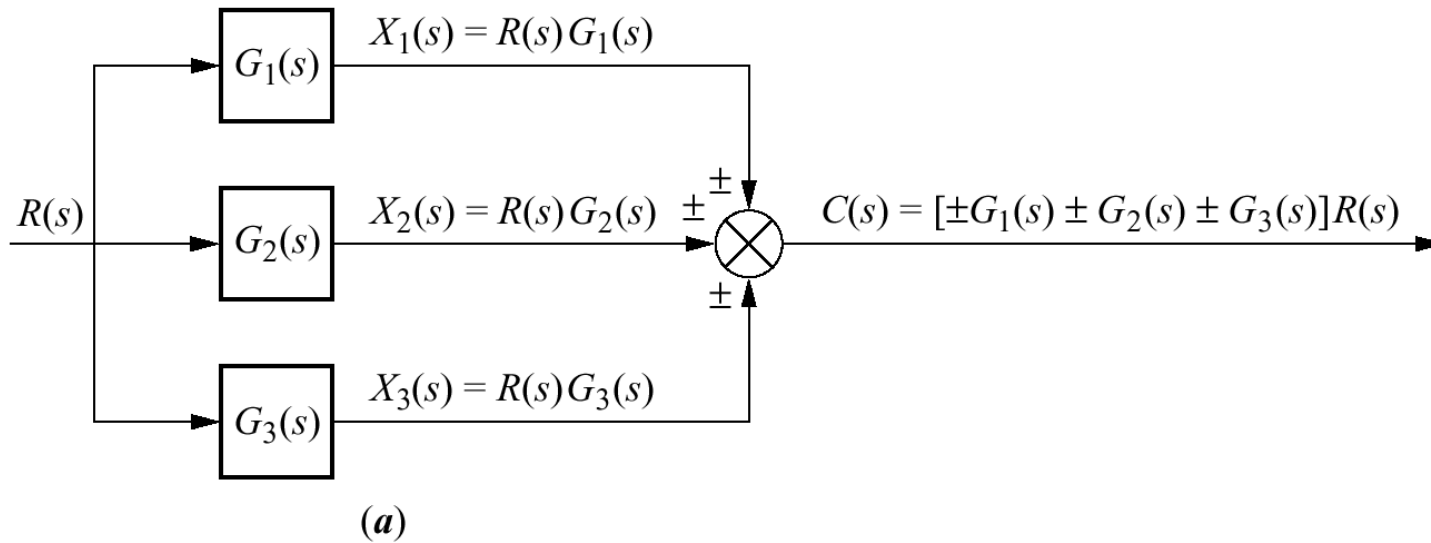



# Figure 5.6

- a. Feedback control system;
- b. simplified model;
- c. equivalent transfer function

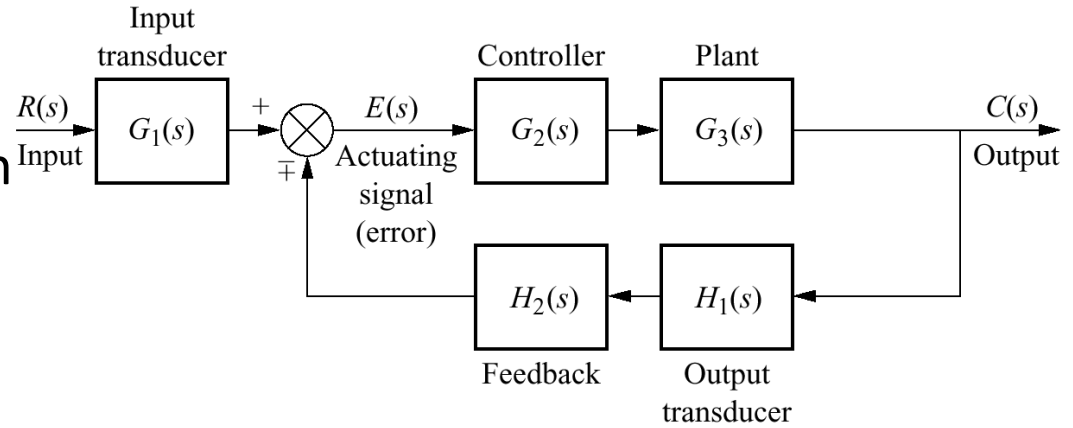

(a)

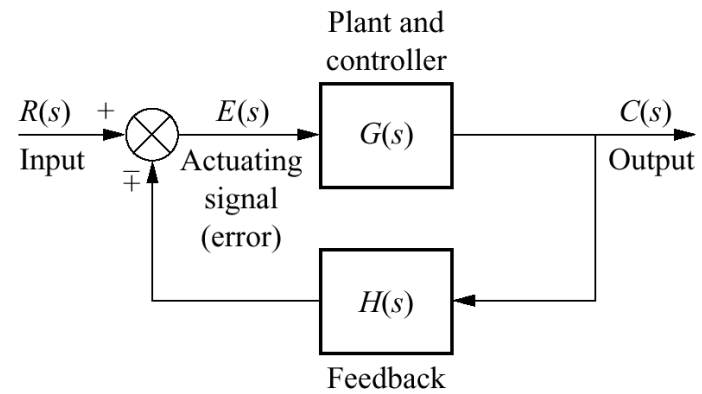

(b)

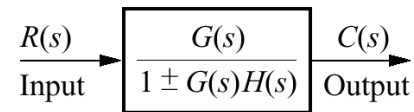

(c)

**Figure 5.7:** Block diagram algebra for summing junctions

equivalent forms for moving a block  
**a.** to the left past a summing junction;  
**b.** to the right past a summing junction

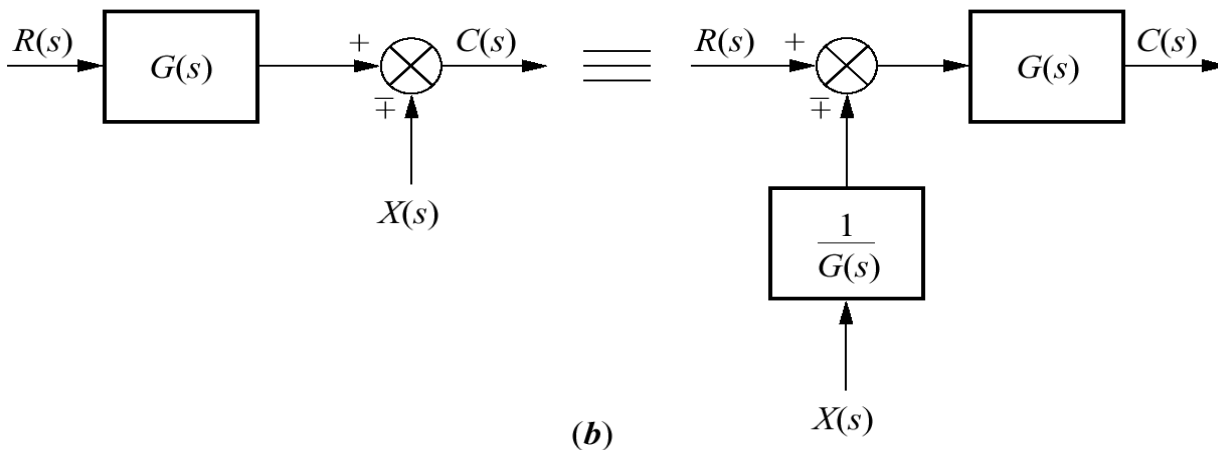
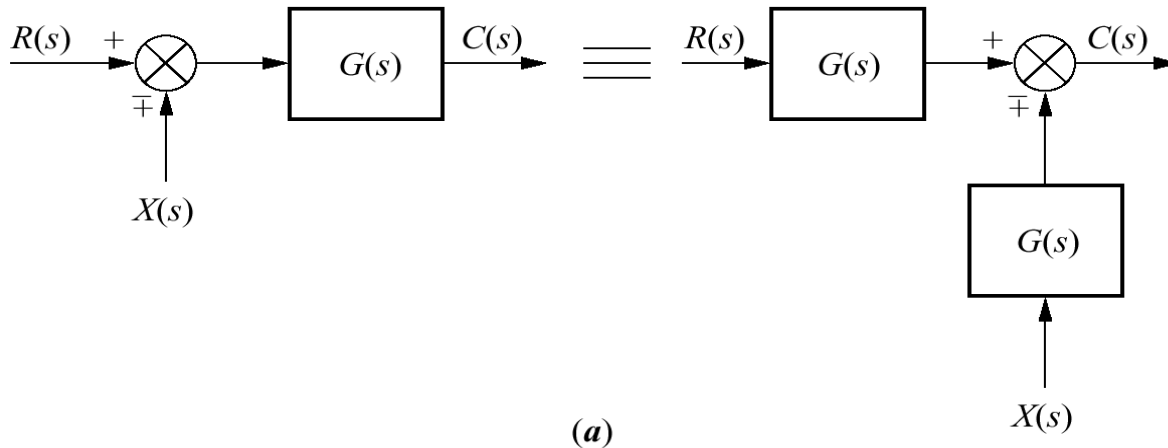

## Figure 5.8: Block diagram algebra for pickoff points

equivalent forms for moving a block

a. to the left past a pickoff point;

b. to the right past a pickoff point

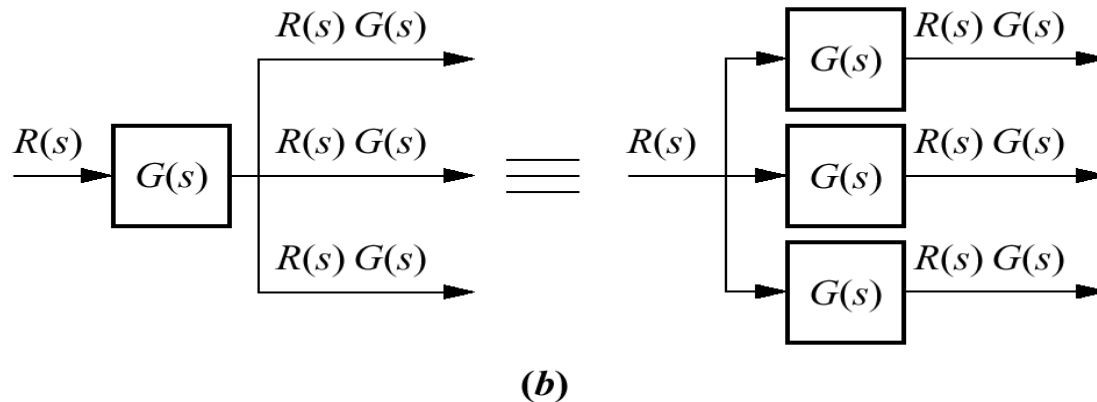
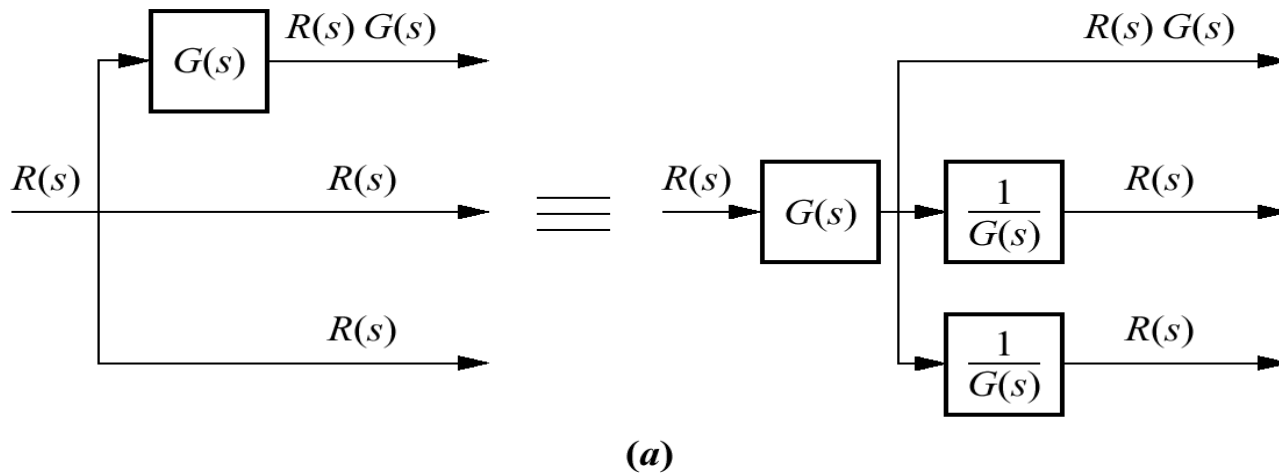

# Block diagram reduction via familiar forms for Example 5.1

**Problem:** Reduce the block diagram shown in figure to a single transfer function

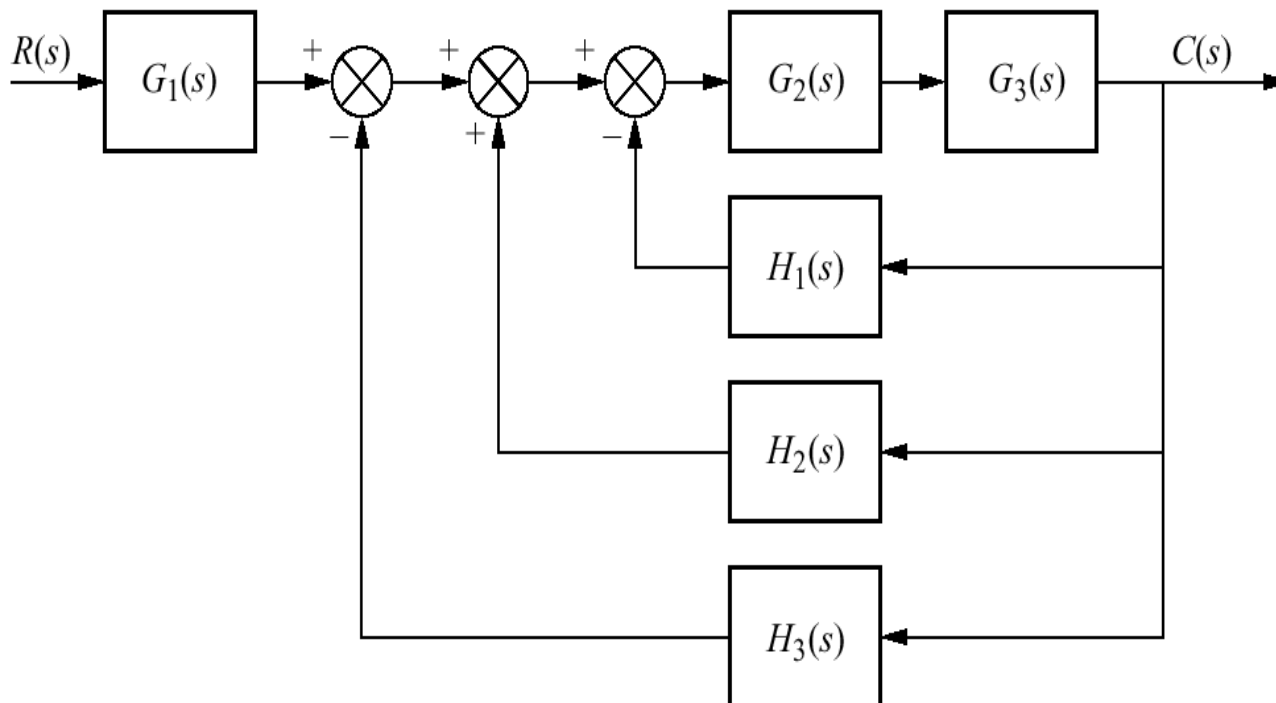

## Block diagram reduction via familiar forms for Example 5.1 Cont.

### Steps in solving Example 5.1:

- a. collapse summing junctions;
- b. form equivalent cascaded system in the forward path
- c. form equivalent parallel system in the feedback path;
- d. form equivalent feedback system and multiply by cascaded  $G_1(s)$

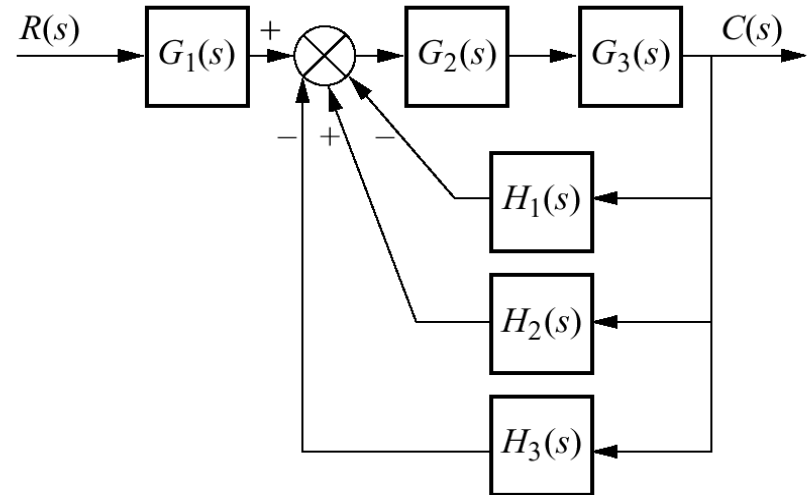

(a)

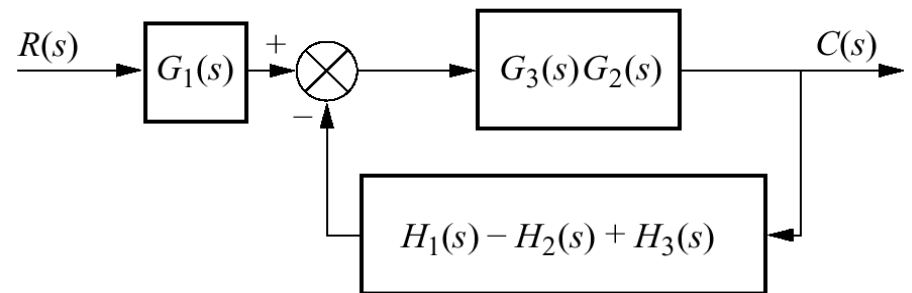

(b)

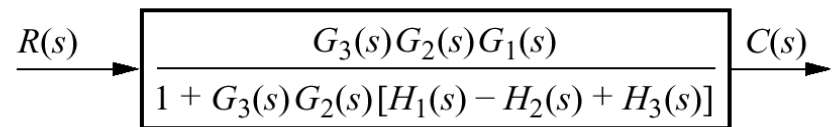

(c)

## Block diagram reduction by moving blocks Example 5.2

Problem: Reduce the block diagram shown in figure to a single transfer function

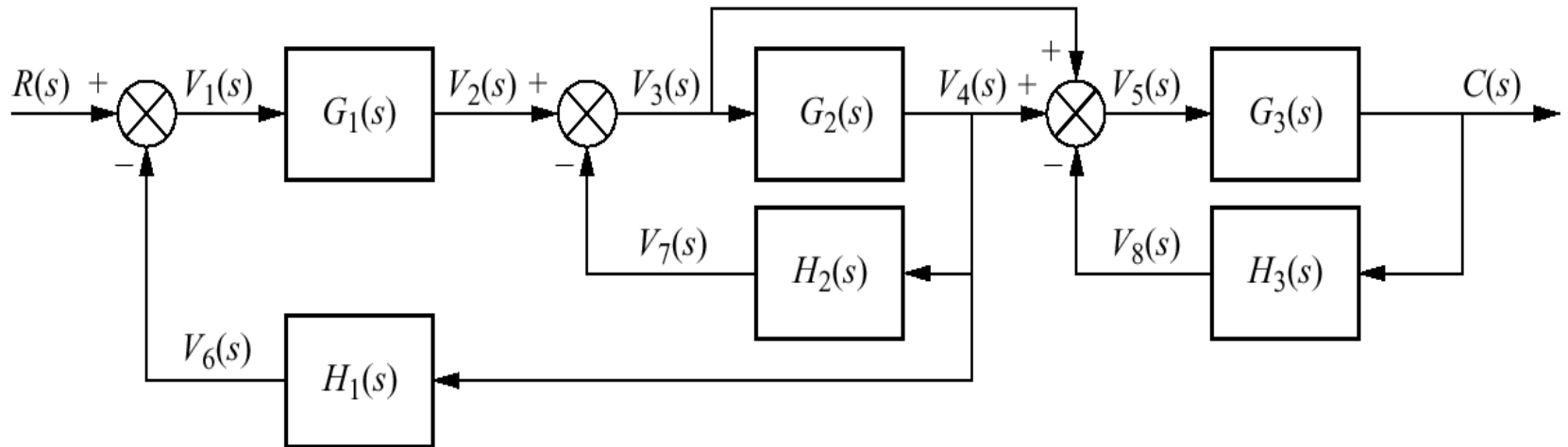

# Steps in the block diagram reduction for Example 5.2

**a)** Move  $G_2(s)$  to the left past of pickoff point to create parallel subsystems, and reduce the feedback system of  $G_3(s)$  and  $H_3(s)$

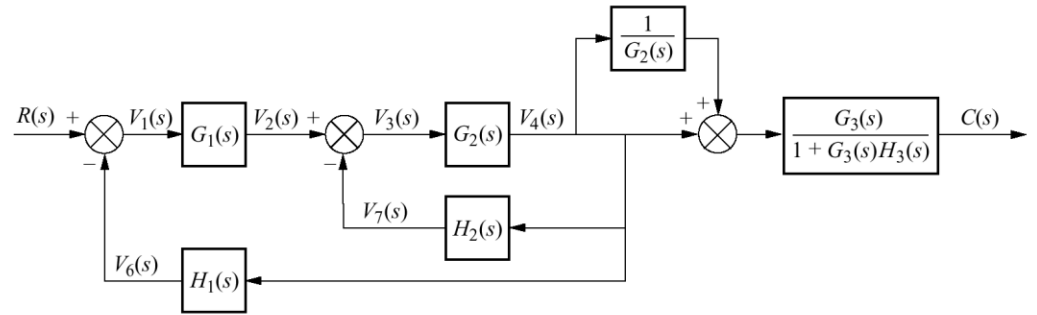

(a)

**b)** Reduce parallel pair of  $1/G_2(s)$  and unity, and push  $G_1(s)$  to the right past summing junction

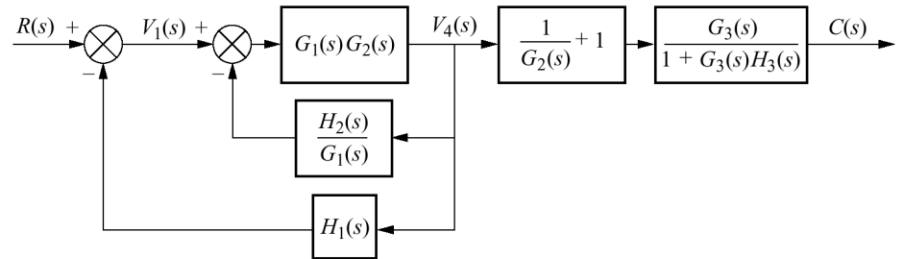

(b)

**c)** Collapse the summing junctions, add the 2 feedback elements, and combine the last 2 cascade blocks

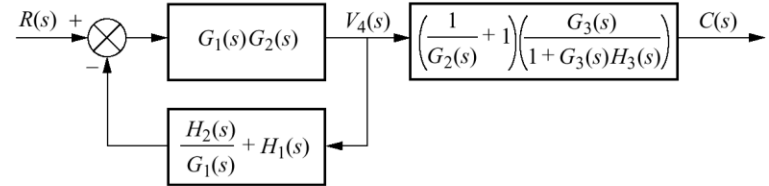

(c)

**d)** Reduce the feedback system to the left

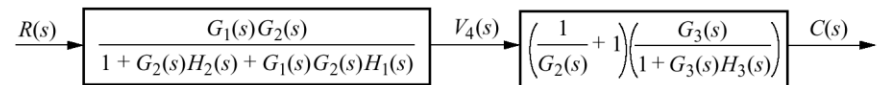

(d)

**e)** finally, Multiple the 2 cascade blocks and obtain final result.

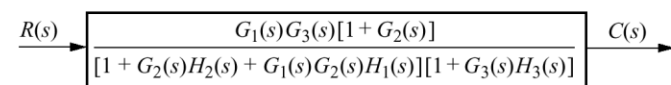

(e)

## Second-order feedback control system

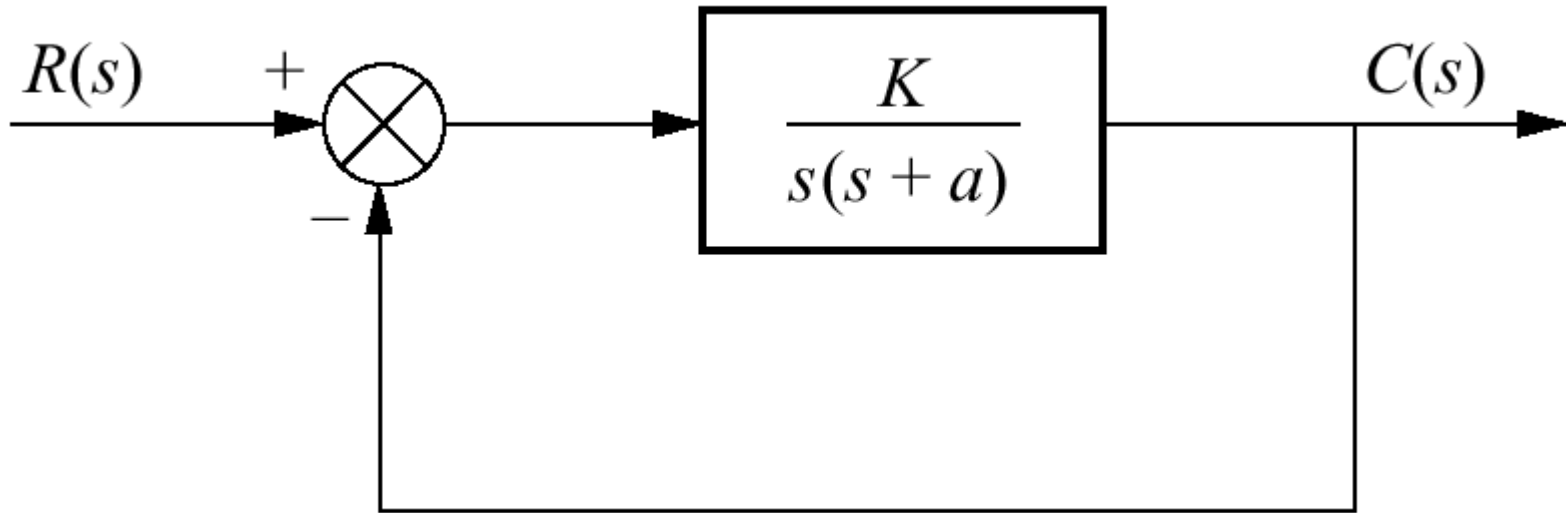

The closed loop transfer function is 
$$T(s) = \frac{K}{s^2 + as + K}$$

Note  $K$  is the amplifier gain, As  $K$  varies, the poles move through the three ranges of operations OD, CD, and UD

$0 < K < a^2/4$  system is over damped

$K = a^2/4$  system is critically damped

$K > a^2/4$  system is under damped



## Finding transient response Example 5.3

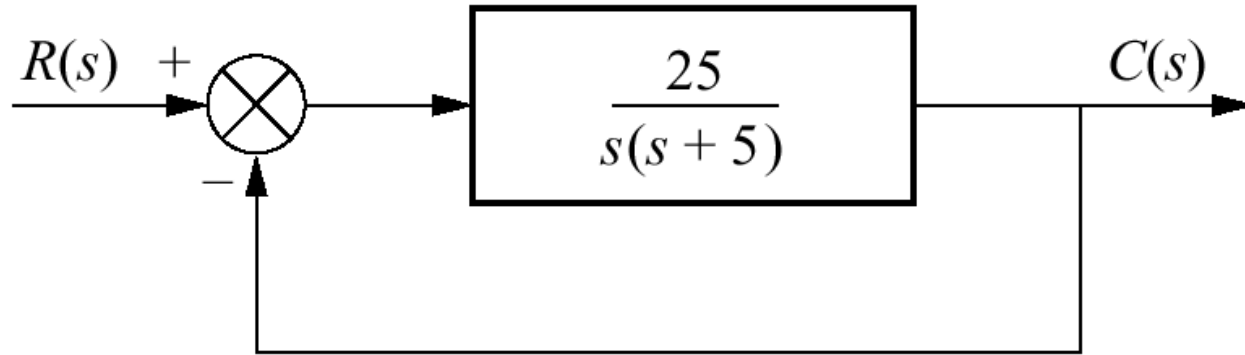

**Problem:** For the system shown, find peak time, percent overshoot, and settling time.

Solution: The closed loop transfer function is  $T(s) = \frac{25}{s^2 + 5s + 25}$

And  $\omega_n = \sqrt{25} = 5$   
 $2\xi\omega_n = 5$  so  $\xi = 0.5$

using values for  $\xi$  and  $\omega_n$  and equation in chapter 4 we find

$$T_p = \frac{\pi}{\omega_n \sqrt{1 - \xi^2}} = 0.726 \text{ sec}$$

$$\%OS = e^{-\xi\pi / \sqrt{1 - \xi^2}} \times 100 = 16.303$$

$$T_s = \frac{4}{\xi\omega_n} = 1.6 \text{ sec}$$

## Gain design for transient response Example 5.4

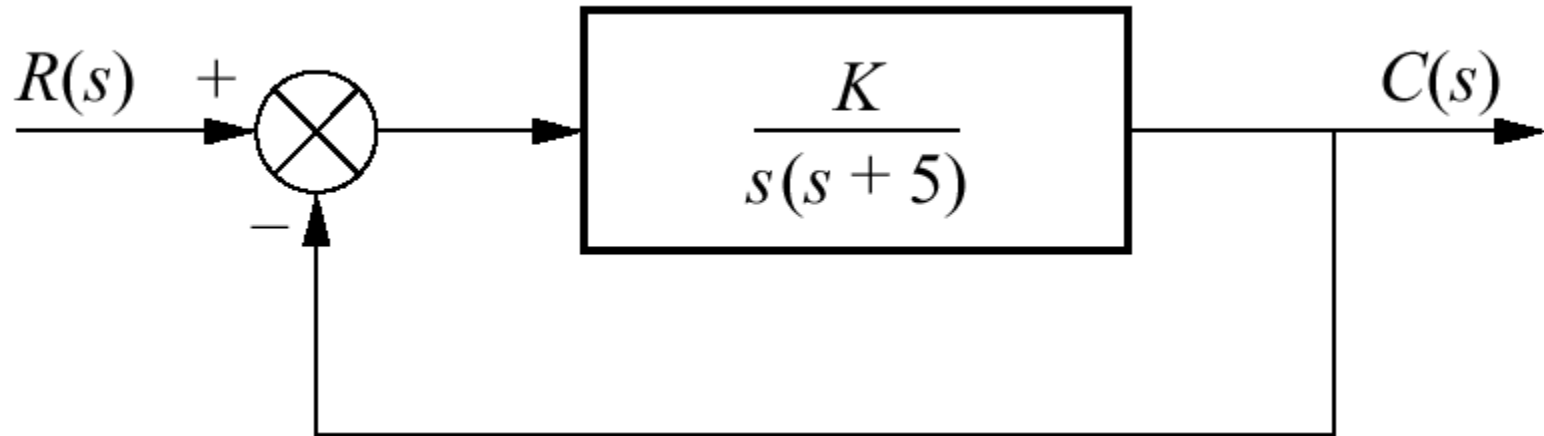

**Problem:** Design the value of gain  $K$ , so that the system will respond with a 10% overshoot.

**Solution:** The closed loop transfer function is  $T(s) = \frac{K}{s^2 + 5s + K}$

$$\omega_n = \sqrt{K} \quad \text{and} \quad 2\xi\omega_n = 5 \quad \text{thus} \quad \xi = \frac{5}{2\sqrt{K}}$$

For 10% OS we find  $\xi = 0.591$

We substitute this value in previous equation to find  $K = 17.9$

# Signal-flow graph components:

- a.** system;
- b.** signal;
- c.** interconnection of systems and signals

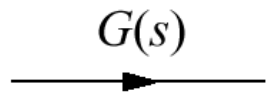

(a)



(b)

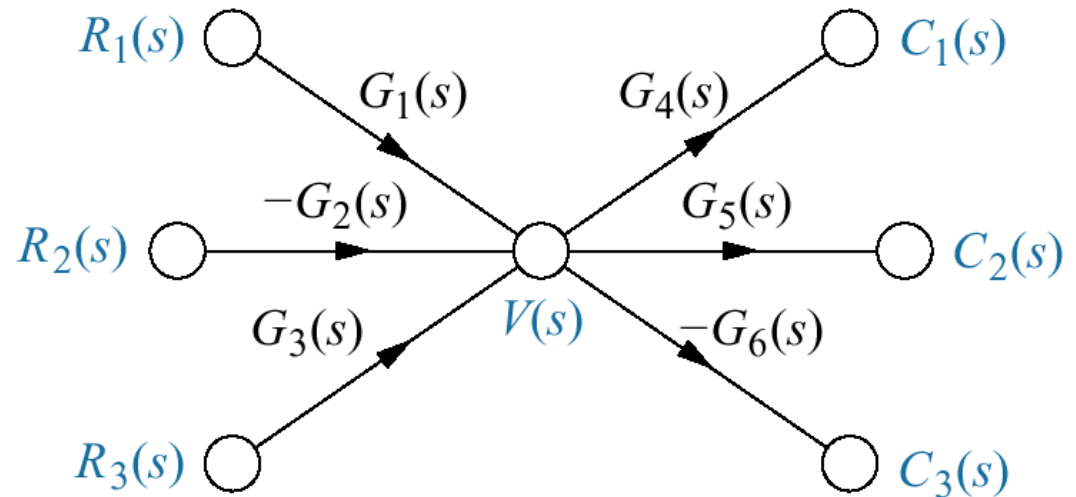

(c)

# Building signal-flow graphs

a. cascaded system nodes

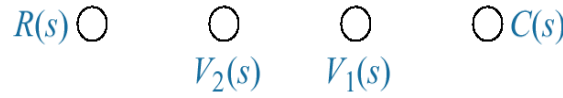

b. cascaded system signal-flow graph;

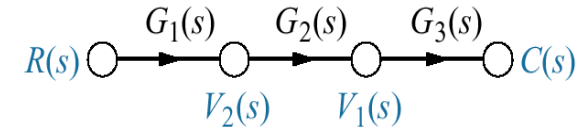

(a)

(b)

c. parallel system nodes



d. parallel system signal-flow graph;

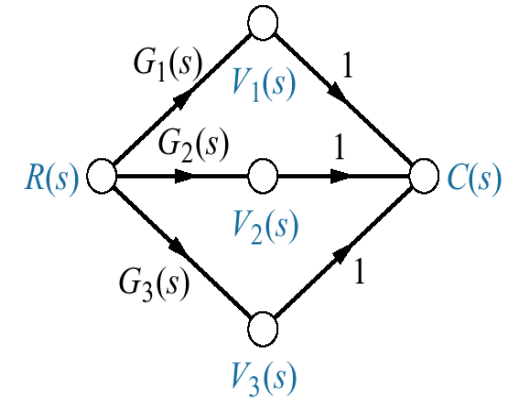

(c)

(d)

e. feedback system nodes



f. feedback system signal-flow graph

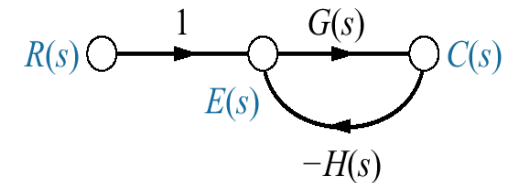

(e)

(f)

## Converting a block diagram to a signal-flow graph

**Problem:** Convert the block diagram to a signal-flow graph.

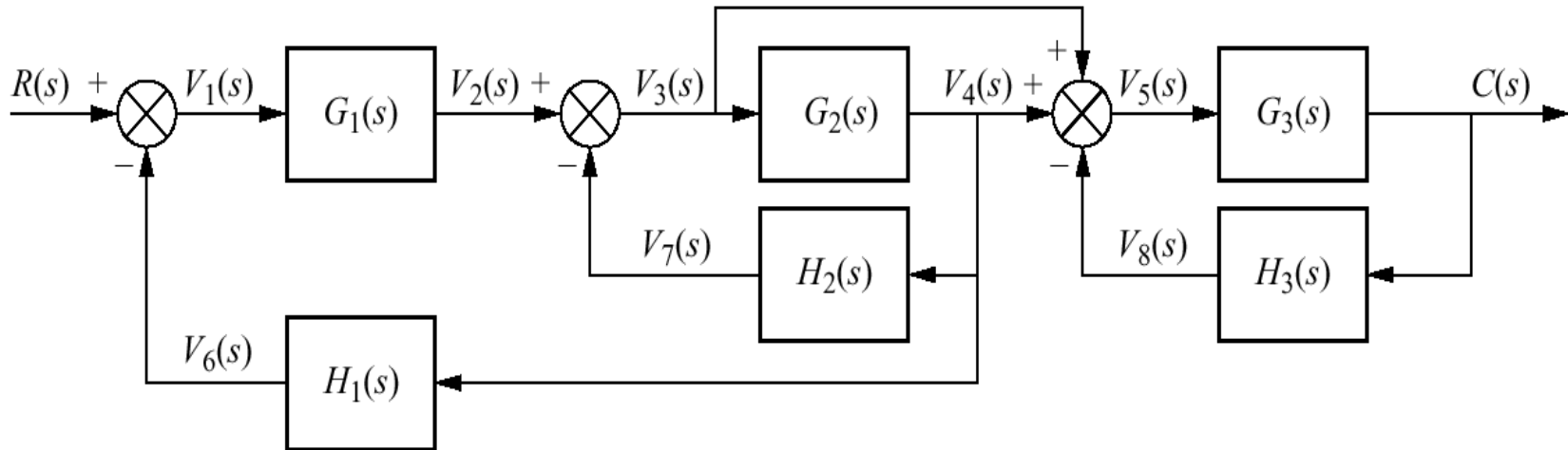

# Converting a block diagram to a signal-flow graph

Signal-flow graph development:

- a. signal nodes;
- b. signal-flow graph;
- c. simplified signal-flow graph

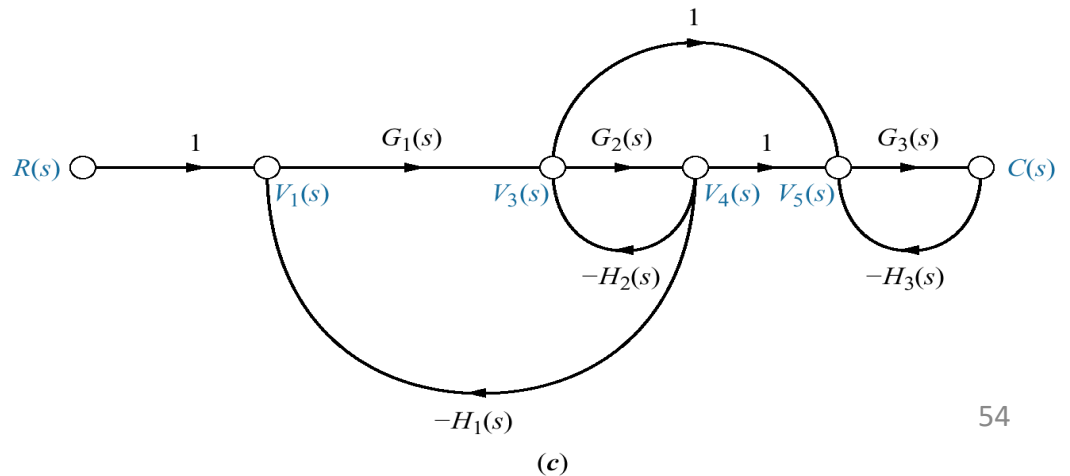
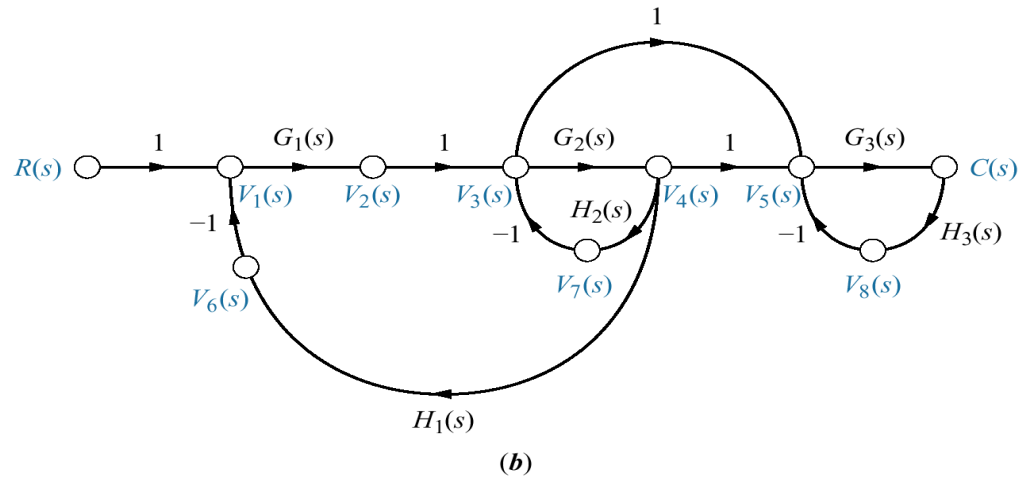
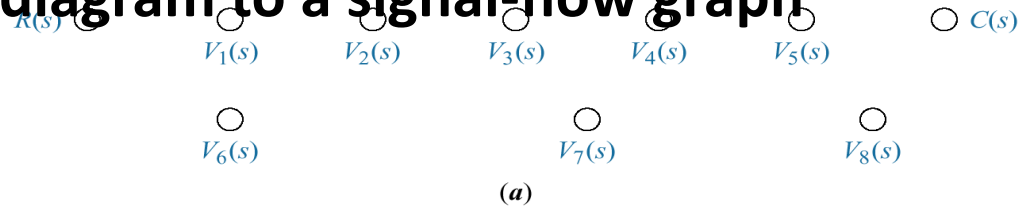

# Mason's rule - Definitions

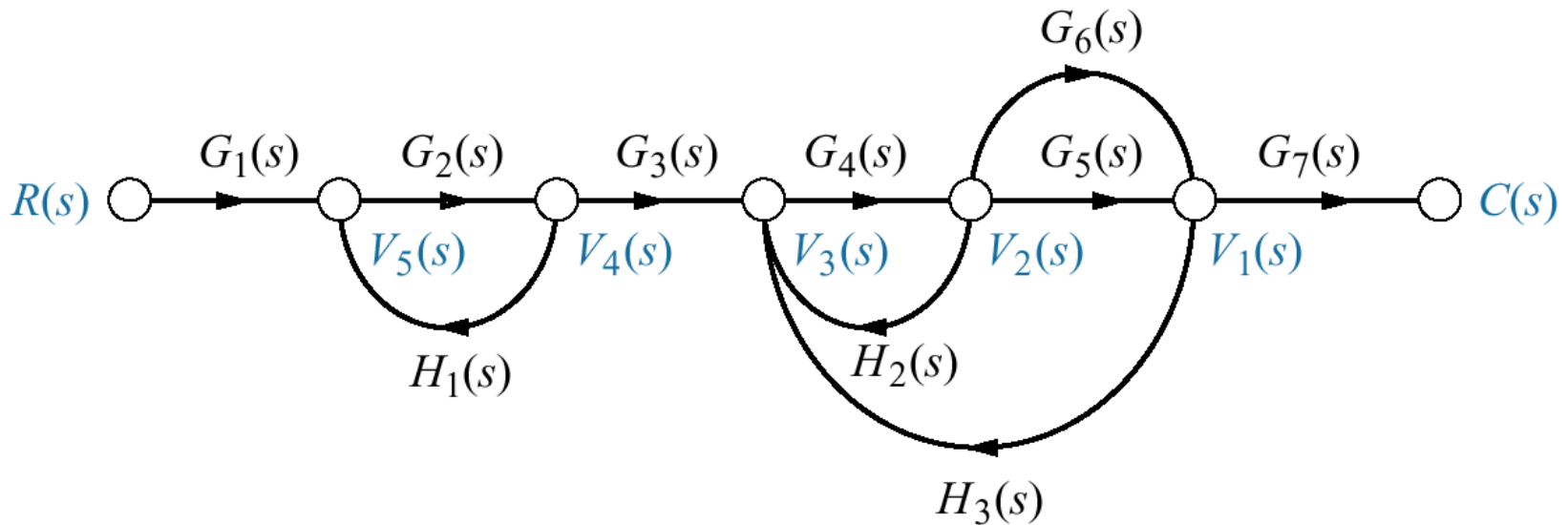

**Loop gain:** The product of branch gains found by traversing a path that starts at a node and ends at the same node, following the direction of the signal flow, without passing through any other node more than once.  $G_2(s)H_2(s)$ ,  $G_4(s)H_2(s)$ ,  $G_4(s)G_5(s)H_3(s)$ ,  $G_4(s)G_6(s)H_3(s)$

**Forward-path gain:** The product of gains found by traversing a path from input node to output node in the direction of signal flow.  $G_1(s)G_2(s)G_3(s)G_4(s)G_5(s)G_7(s)$ ,  $G_1(s)G_2(s)G_3(s)G_4(s)G_5(s)G_7(s)$

**Nontouching loops:** loops that do not have any nodes in common.  $G_2(s)H_1(s)$  does not touch  $G_4(s)H_2(s)$ ,  $G_4(s)G_5(s)H_3(s)$ , and  $G_4(s)G_6(s)H_3(s)$

**Nontouching-loop gain:** The product of loop gains from nontouching loops taken 2, 3, 4, or more at a time.

$[G_2(s)H_1(s)][G_4(s)H_2(s)]$ ,  $[G_2(s)H_1(s)][G_4(s)G_5(s)H_3(s)]$ ,  $[G_2(s)H_1(s)][G_4(s)G_6(s)H_3(s)]$

# Mason's Rule

The Transfer function.  $C(s)/R(s)$ , of a system represented by a signal-flow graph is

$$G(s) = \frac{C(s)}{R(s)} = \frac{\sum_k T_k \Delta_k}{\Delta}$$

Where

$K$  = number of forward paths

$T_k$  = the  $k$ th forward-path gain

$\Delta = 1 - \sum \text{loop gains} + \sum \text{nontouching-loop gains taken 2 at a time} - \sum \text{nontouching-loop gains taken 3 at a time} + \sum \text{nontouching-loop gains taken 4 at a time} - \dots$

$\Delta_k = \Delta - \sum \text{loop gain terms in } \Delta \text{ that touch the } k\text{th forward path.}$  In other words,  $\Delta_k$  is formed by eliminating from  $\Delta$  those loop gains that touch the  $k$ th forward path.



# Transfer function via Mason's rule

**Problem:** Find the transfer function for the signal flow graph

**Solution:**

forward path

$$G_1(s)G_2(s)G_3(s)G_4(s)G_5(s)$$

Loop gains

$$G_2(s)H_1(s), G_4(s)H_2(s), G_7(s)H_4(s), \\ G_2(s)G_3(s)G_4(s)G_5(s)G_6(s)G_7(s)G_8(s)$$

Nontouching loops

2 at a time

$$G_2(s)H_1(s)G_4(s)H_2(s) \\ G_2(s)H_1(s)G_7(s)H_4(s) \\ G_4(s)H_2(s)G_7(s)H_4(s)$$

3 at a time  $G_2(s)H_1(s)G_4(s)H_2(s)G_7(s)H_4(s)$

Now

$$\Delta = 1 - [G_2(s)H_1(s) + G_4(s)H_2(s) + G_7(s)H_4(s) + G_2(s)G_3(s)G_4(s)G_5(s)G_6(s)G_7(s)G_8(s)] + [G_2(s)H_1(s)G_4(s)H_2(s) + G_2(s)H_1(s)G_7(s)H_4(s) + G_4(s)H_2(s)G_7(s)H_4(s)] - [G_2(s)H_1(s)G_4(s)H_2(s)G_7(s)H_4(s)]$$

$$\Delta_1 = 1 - G_7(s)H_4(s)$$

$$G(s) = \frac{T_1 \Delta_1}{\Delta} = \frac{[G_1(s)G_2(s)G_3(s)G_4(s)G_5(s)][1 - G_7(s)H_4(s)]}{\Delta}$$

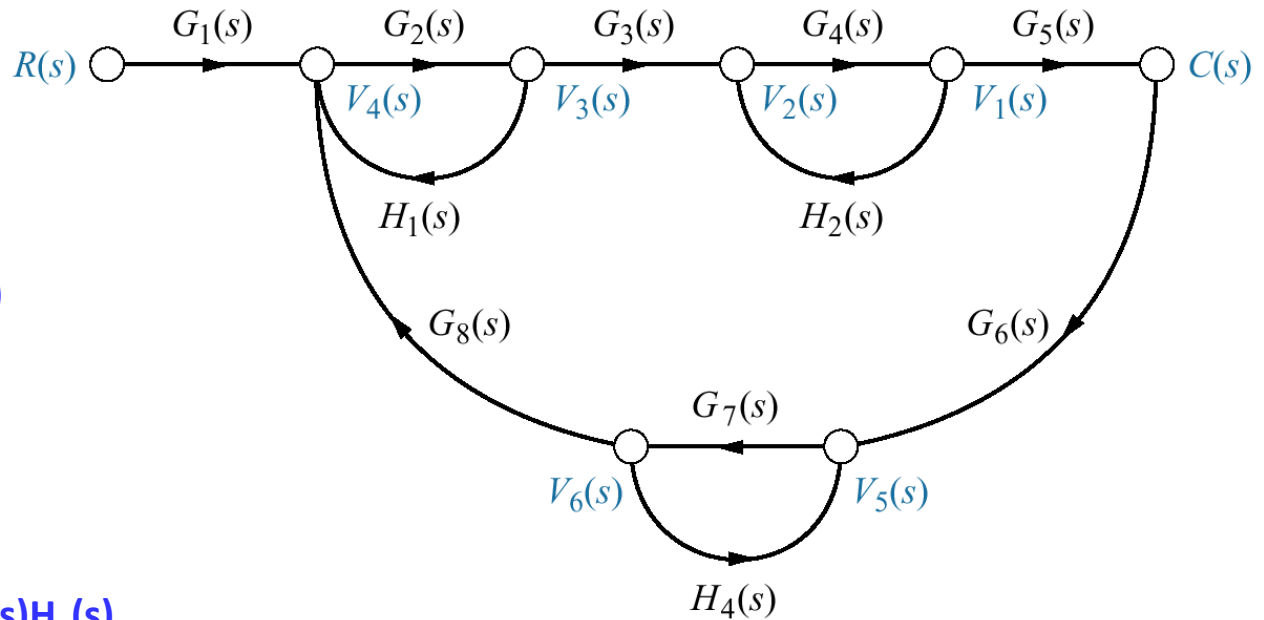

# Signal-Flow Graphs of State Equations

□ **Problem:** draw signal-flow graph for:

$$x_1 = 2x_1 - 5x_2 + 3x_3 + 2r$$

$$x_2 = -6x_1 - 2x_2 + 2x_3 + 5r$$

$$x_3 = x_1 - 3x_2 - 4x_3 + 7r$$

$$y = -4x_1 + 6x_2 + 9x_3$$

- a. place nodes;
- b. interconnect state variables and derivatives;
- c. form  $dx_1/dt$  ;
- d. form  $dx_2/dt$

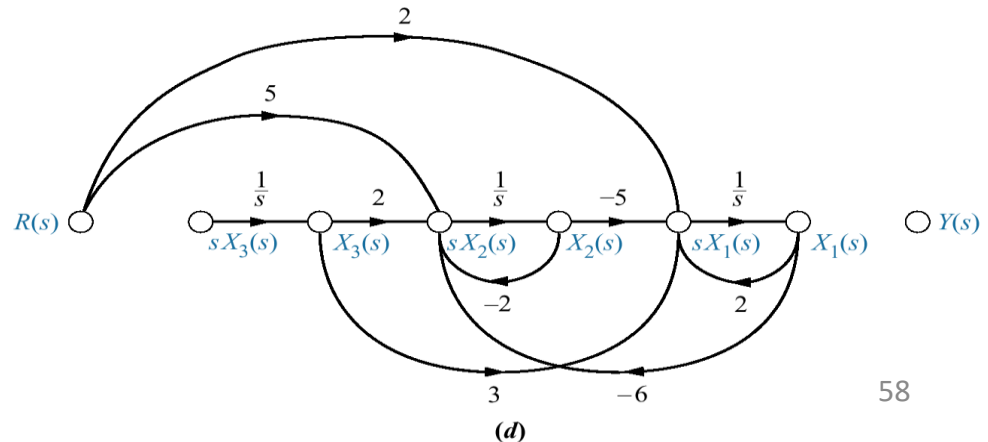
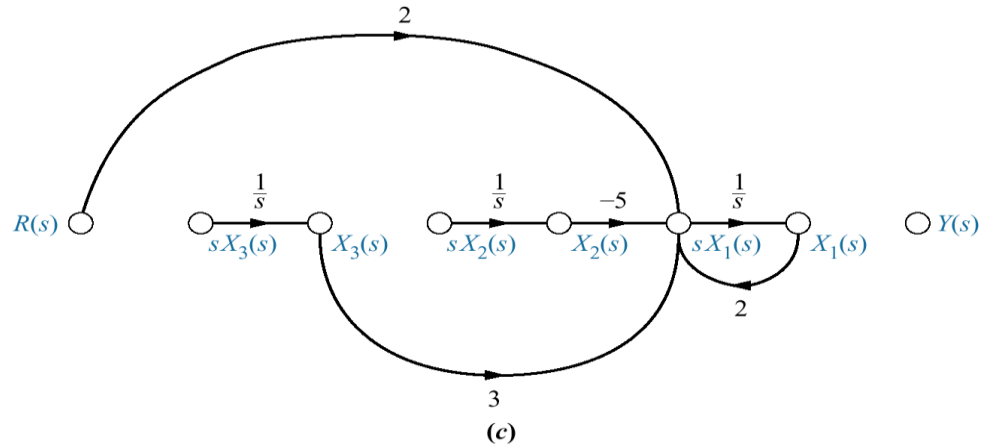
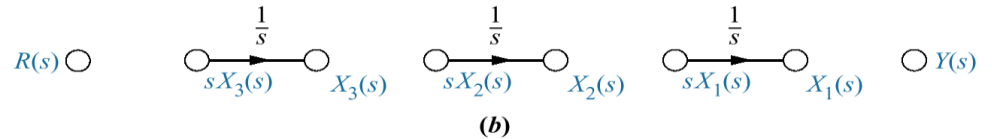
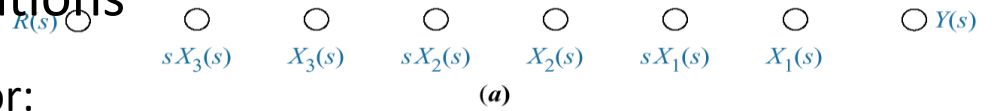

# Signal-Flow Graphs of State Equations

- (continued)  
 e. form  $dx_3/dt$ ;  
 f. form output

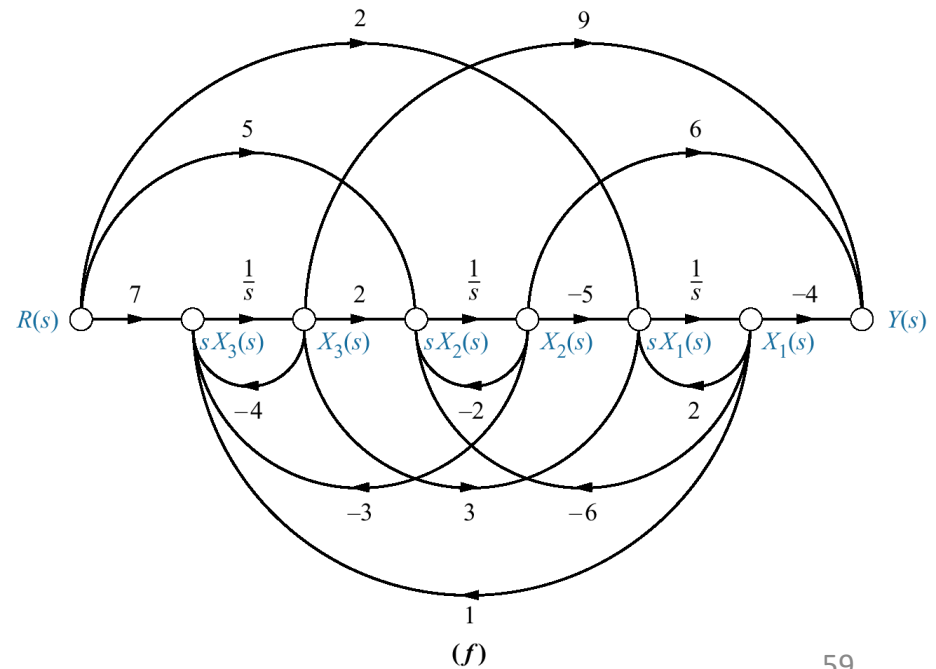
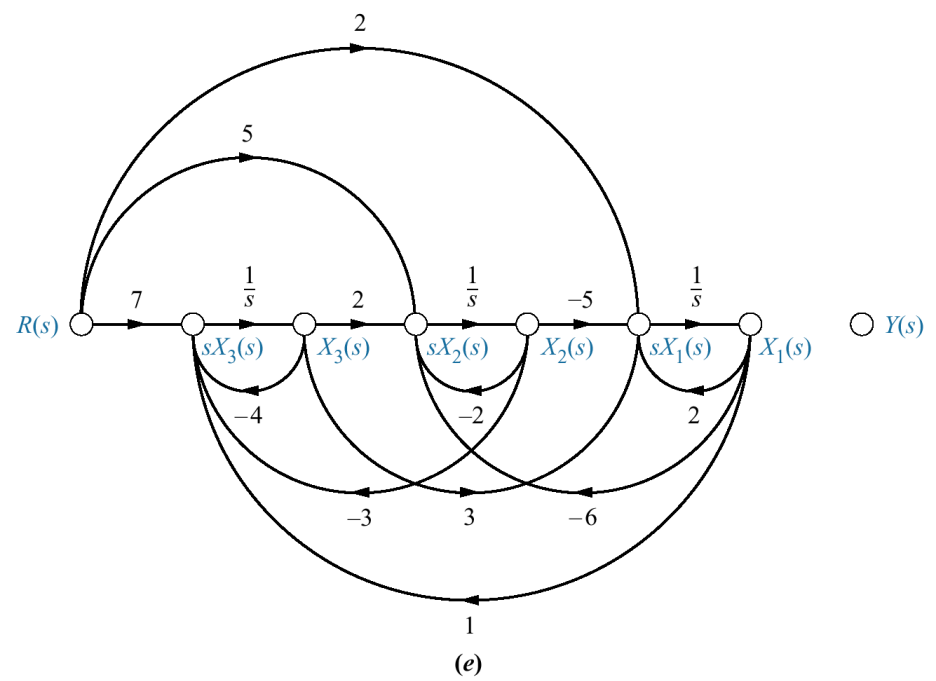

## Alternate Representation: Cascade Form

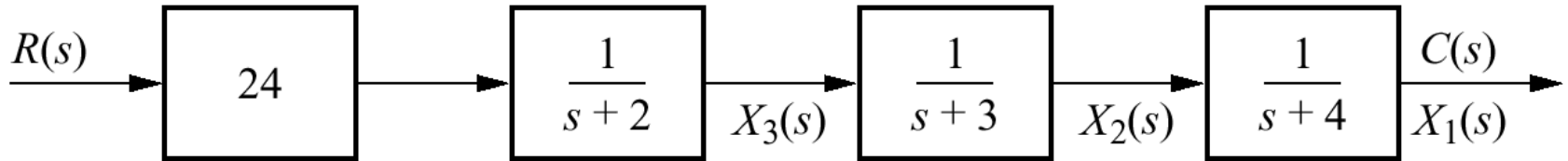

$$\frac{C(s)}{R(s)} = \frac{24}{(s+2)(s+3)(s+4)}$$

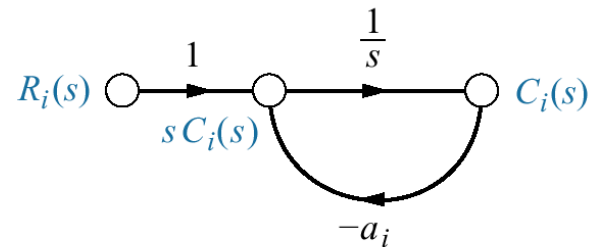

(a)

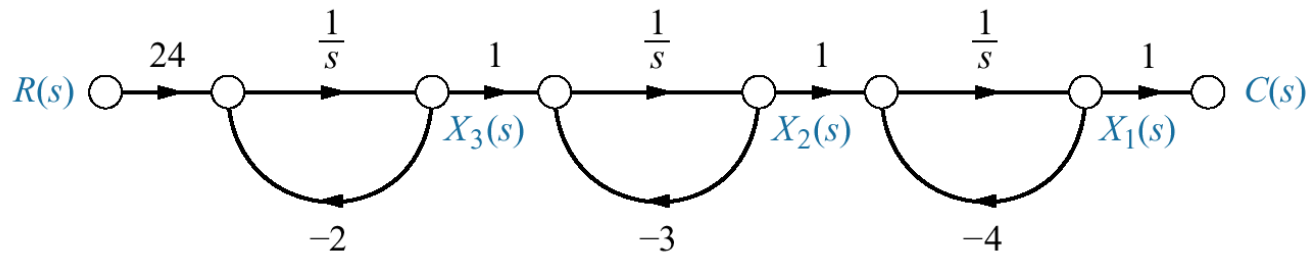

(b)

## Alternate Representation: Cascade Form

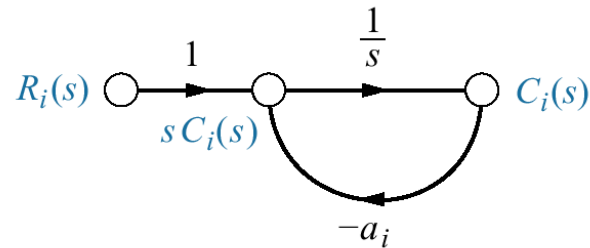

(a)

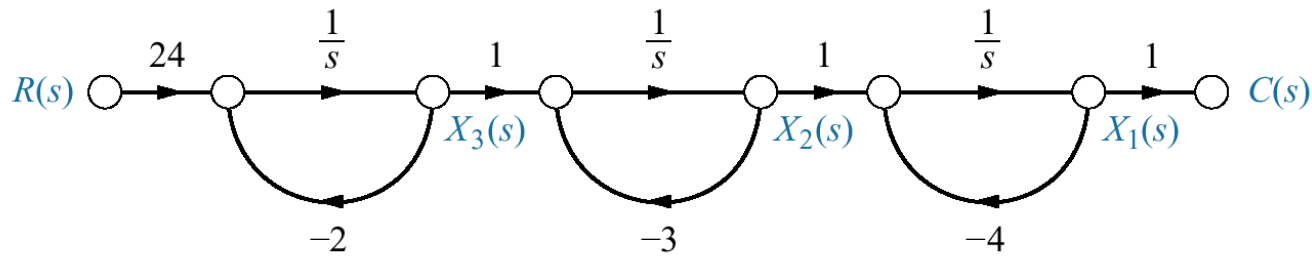

(b)

$$\square \quad x_1 = -4x_1 + x_2$$

$$\square \quad x_2 = -3x_2 + x_3$$

$$\square \quad x_3 = -2x_3 + 24r$$

$$y = c(t) = x_1$$

$$\square \quad X = \begin{bmatrix} -4 & 1 & 0 \\ 0 & -3 & 1 \\ 0 & 0 & -2 \end{bmatrix} X + \begin{bmatrix} 0 \\ 0 \\ 24 \end{bmatrix} r$$

$$y = [1 \ 0 \ 0] X$$

$$\frac{C(s)}{R(s)} = \frac{\text{Alternate Representation: Parallel Form}}{(s+2)(s+3)(s+4)} = \frac{12}{(s+2)} - \frac{24}{(s+3)} + \frac{12}{(s+4)}$$

$$\begin{aligned} \dot{x}_1 &= -2x_1 + 12r \\ \dot{x}_2 &= -3x_2 - 24r \\ \dot{x}_3 &= -4x_3 + 12r \\ y = c(t) &= x_1 + x_2 + x_3 \end{aligned}$$

$$\dot{X} = \begin{bmatrix} -2 & 0 & 0 \\ 0 & -3 & 0 \\ 0 & 0 & -4 \end{bmatrix} X + \begin{bmatrix} 12 \\ -24 \\ 12 \end{bmatrix} r$$

$$y = [1 \ 1 \ 1]X$$

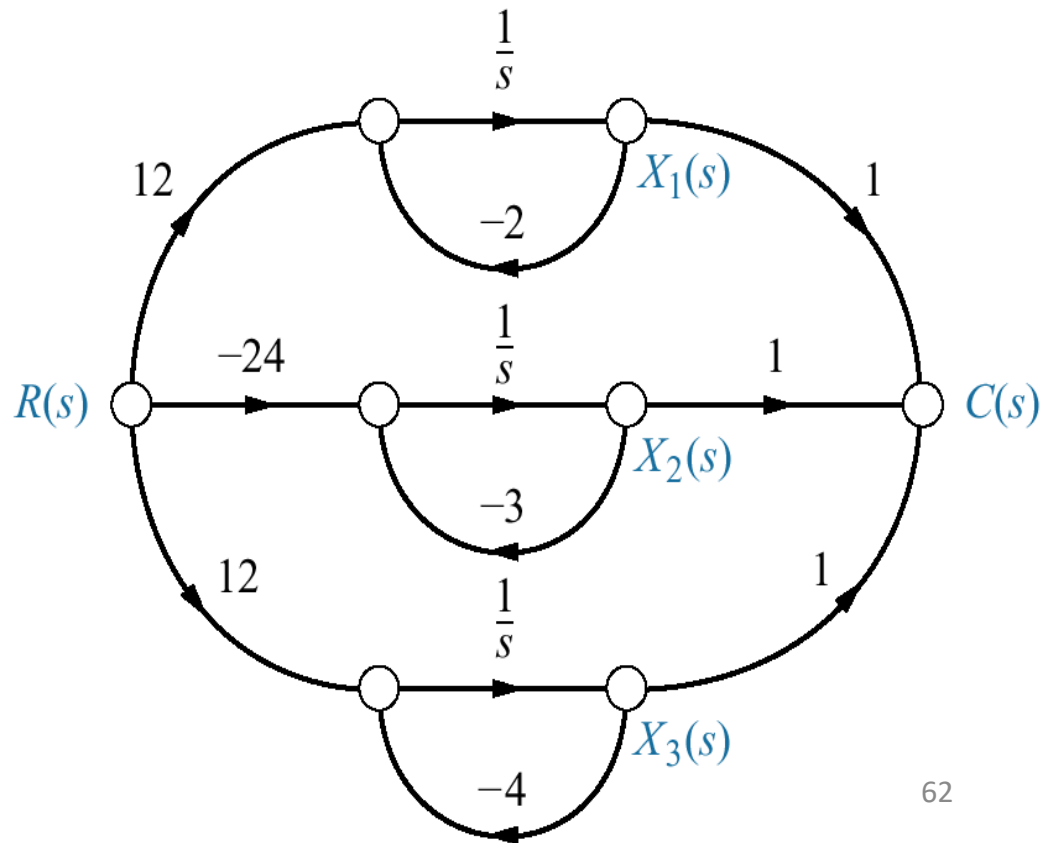

## Alternate Representation: Parallel Form Repeated roots

$$\frac{C(s)}{R(s)} = \frac{(s+3)}{(s+1)^2(s+2)} = \frac{2}{(s+1)^2} - \frac{1}{(s+1)} + \frac{1}{(s+2)}$$

$$\begin{aligned} \dot{x}_1 &= -x_1 + x_2 \\ \dot{x}_2 &= x_2 + 2r \\ \dot{x}_3 &= -2x_3 + r \\ y = c(t) &= x_1 - \frac{1}{2}x_2 + x_3 \end{aligned}$$

$$\dot{X} = \begin{bmatrix} -1 & 1 & 0 \\ 0 & -1 & 0 \\ 0 & 0 & -2 \end{bmatrix} X + \begin{bmatrix} 0 \\ 2 \\ 1 \end{bmatrix} r$$

$$y = [1 \quad -1/2 \quad 1] X$$

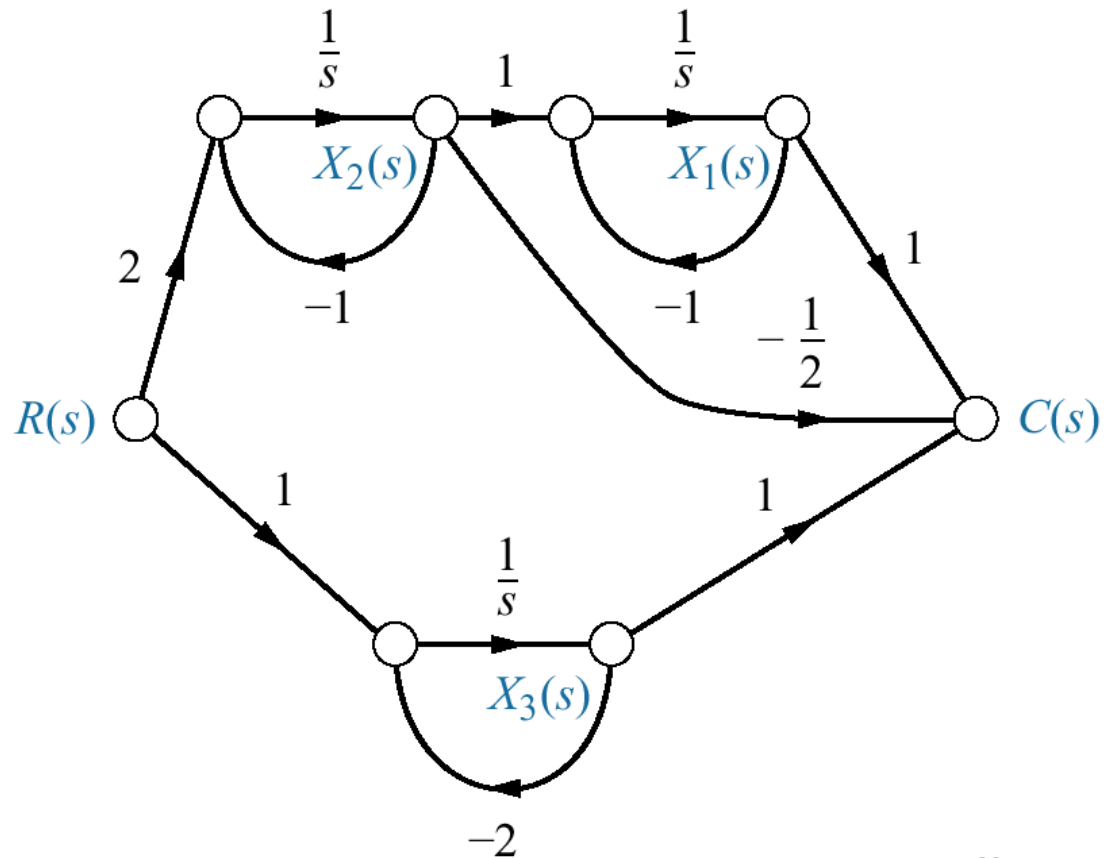

## Alternate Representation: controller canonical form

$$G(s) = C(s)/R(s) = (s^2 + 7s + 2)/(s^3 + 9s^2 + 26s + 24)$$

This form is obtained from the phase-variable form simply by ordering the phase variable in reverse order

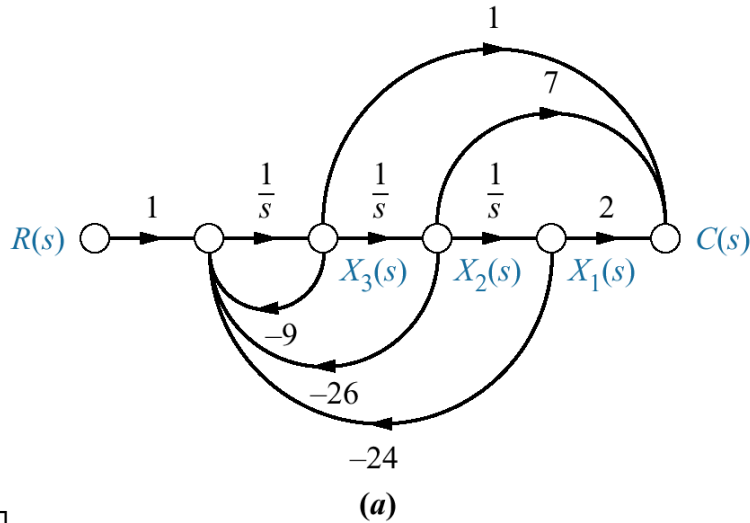

$$\begin{bmatrix} \square \\ x_1 \\ \square \\ x_2 \\ \square \\ x_3 \end{bmatrix} = \begin{bmatrix} 0 & 1 & 0 \\ 0 & 0 & 1 \\ -24 & -26 & -9 \end{bmatrix} \begin{bmatrix} x_1 \\ x_2 \\ x_3 \end{bmatrix} + \begin{bmatrix} 0 \\ 0 \\ 1 \end{bmatrix} r$$

$$y = \begin{bmatrix} 2 & 7 & 1 \end{bmatrix} \begin{bmatrix} x_1 \\ x_2 \\ x_3 \end{bmatrix}$$

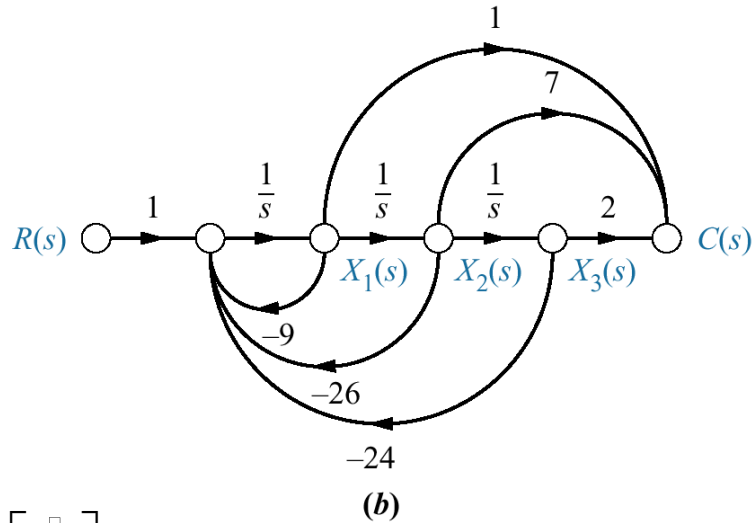

$$\begin{bmatrix} \square \\ x_1 \\ \square \\ x_2 \\ \square \\ x_3 \end{bmatrix} = \begin{bmatrix} -9 & -26 & -24 \\ 1 & 0 & 0 \\ 0 & 1 & 0 \end{bmatrix} \begin{bmatrix} x_1 \\ x_2 \\ x_3 \end{bmatrix} + \begin{bmatrix} 1 \\ 0 \\ 0 \end{bmatrix} r$$

$$y = \begin{bmatrix} 1 & 7 & 2 \end{bmatrix} \begin{bmatrix} x_1 \\ x_2 \\ x_3 \end{bmatrix}$$



## Alternate Representation: controller canonical form

System matrices that contain the coefficients of the characteristic polynomial are called *companion matrices* to the characteristic polynomial.

Phase-variable form result in lower companion matrix

Controller canonical form results in upper companion matrix

## Alternate Representation: observer canonical form

Observer canonical form so named for its use in the design of observers

$$G(s) = C(s)/R(s) = (s^2 + 7s + 2)/(s^3 + 9s^2 + 26s + 24)$$

$$= (1/s + 7/s^2 + 2/s^3) / (1 + 9/s + 26/s^2 + 24/s^3)$$

Cross multiplying

$$(1/s + 7/s^2 + 2/s^3)R(s) = (1 + 9/s + 26/s^2 + 24/s^3)C(s)$$

$$\text{And } C(s) = 1/s[R(s) - 9C(s)] + 1/s^2[7R(s) - 26C(s)] + 1/s^3[2R(s) - 24C(s)]$$

$$= 1/s \{ [R(s) - 9C(s)] + 1/s \{ [7R(s) - 26C(s)] + 1/s [2R(s) - 24C(s)] \} \}$$

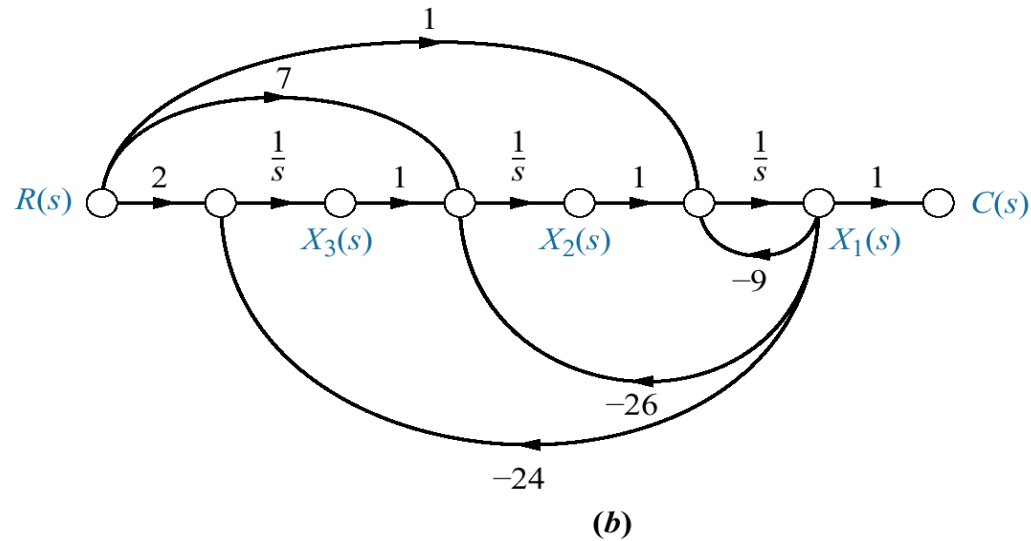
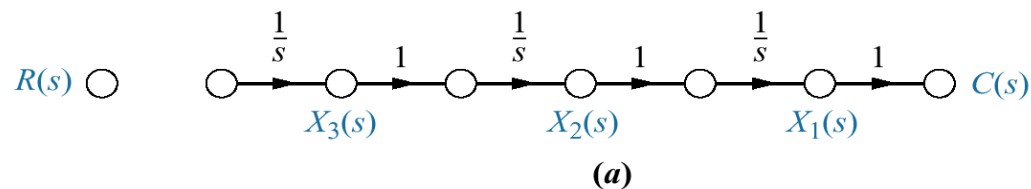

# Alternate Representation: observer canonical form

$$\dot{x}_1 = -9x_1 + x_2 + r$$

$$\dot{x}_2 = -26x_1 + x_3 + 7r$$

$$\dot{x}_3 = -24x_1 + 2r$$

$$y = c(t) = x_1$$

$$\dot{X} = \begin{bmatrix} -9 & 1 & 0 \\ -26 & 0 & 1 \\ -24 & 0 & 0 \end{bmatrix} X + \begin{bmatrix} 1 \\ 7 \\ 2 \end{bmatrix} r$$

$$y = [1 \ 0 \ 0]X$$

**Note that the observer form has A matrix that is transpose of the controller canonical form, B vector is the transpose of the controller C vector, and C vector is the transpose of the controller B vector. The 2 forms are called duals.**

# Feedback control system for Example 5.8

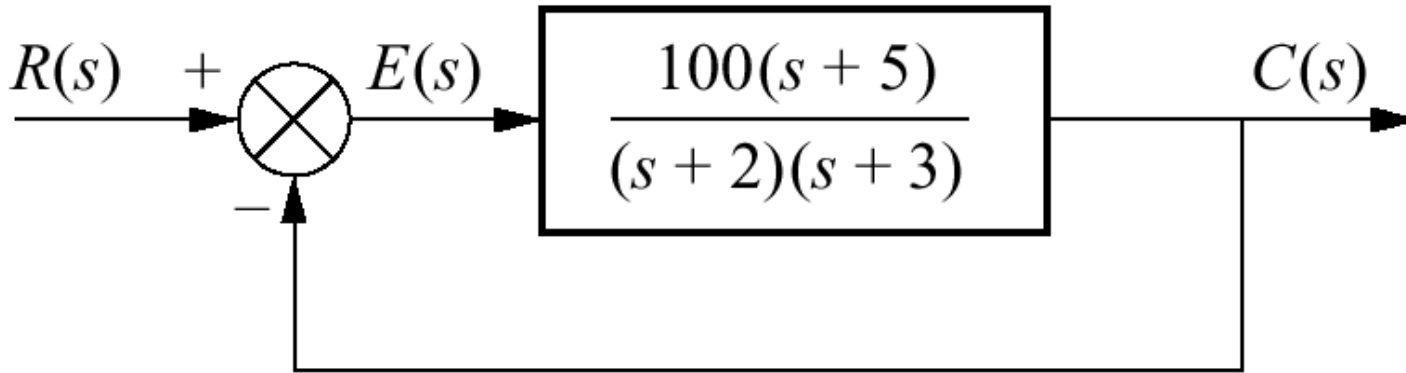

**Problem** Represent the feedback control system shown in state space. Model the forward transfer function in cascade form.

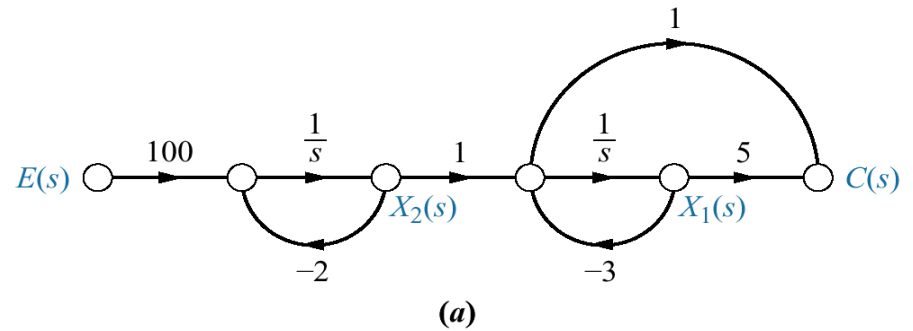

**Solution** first we model the forward transfer function as in (a), Second we add the feedback and input paths as shown in (b) complete system.

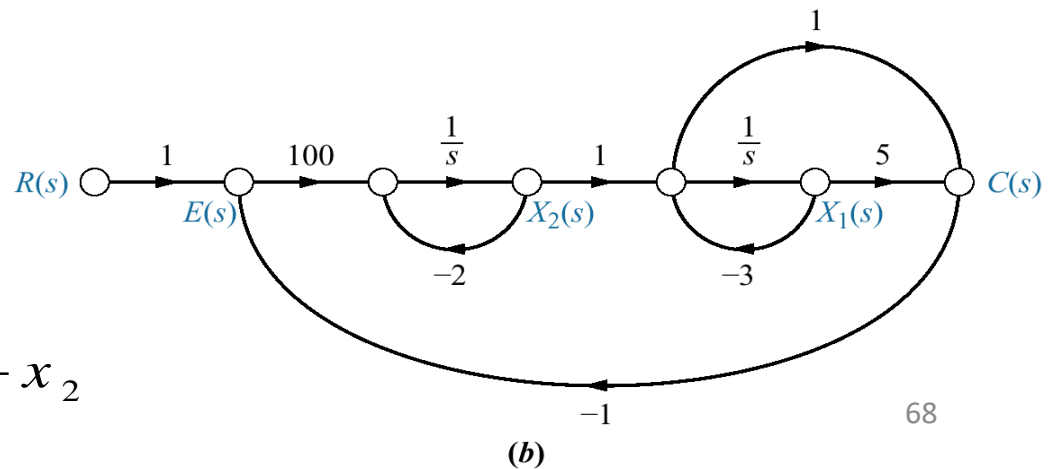

$$\dot{x}_1 = -3x_1 + x_2$$

$$\dot{x}_2 = -2x_2 + 100(r - c)$$

$$\text{but } c = 5x_1 + (x_2 - 3x_1) = 2x_1 + x_2$$

## Feedback control system for Example 5.8

$$\dot{x}_1 = -3x_1 + x_2$$

$$\dot{x}_2 = -200x_1 - 102x_2 + 100r$$

$$y = c(t) = 2x_1 + x_2$$

$$\dot{X} = \begin{bmatrix} -3 & 1 \\ -200 & -102 \end{bmatrix} X + \begin{bmatrix} 0 \\ 100 \end{bmatrix} r$$

$$y = [2 \quad 1] X$$

State-space forms for  
 $C(s)/R(s) = (s+3)/[(s+4)(s+6)]$ .  
 Note:  $y = c(t)$

Form	Transfer Function	Signal-Flow Diagram	State Equations
Phase variable	$\frac{1}{(s^2 + 10s + 24)} * (s + 3)$		$\dot{\mathbf{x}} = \begin{bmatrix} 0 & 1 \\ -24 & -10 \end{bmatrix} \mathbf{x} + \begin{bmatrix} 0 \\ 1 \end{bmatrix} r$ $y = [3 \quad 1] \mathbf{x}$
Parallel	$\frac{-1/2}{(s+4)} + \frac{3/2}{s+6}$		$\dot{\mathbf{x}} = \begin{bmatrix} -4 & 0 \\ 0 & -6 \end{bmatrix} \mathbf{x} + \begin{bmatrix} -1/2 \\ 3/2 \end{bmatrix} r$ $y = [1 \quad 1] \mathbf{x}$
Cascade	$\frac{1}{(s+4)} * \frac{(s+3)}{(s+6)}$		$\dot{\mathbf{x}} = \begin{bmatrix} -6 & 1 \\ 0 & -4 \end{bmatrix} \mathbf{x} + \begin{bmatrix} 0 \\ 1 \end{bmatrix} r$ $y = [-3 \quad 1] \mathbf{x}$
Controller canonical	$\frac{1}{(s^2 + 10s + 24)} * (s + 3)$		$\dot{\mathbf{x}} = \begin{bmatrix} -10 & -24 \\ 1 & 0 \end{bmatrix} \mathbf{x} + \begin{bmatrix} 1 \\ 0 \end{bmatrix} r$ $y = [1 \quad 3] \mathbf{x}$
Observer canonical	$\frac{\frac{1}{s} + \frac{3}{s^2}}{1 + \frac{10}{s} + \frac{24}{s^2}}$		$\dot{\mathbf{x}} = \begin{bmatrix} -10 & 1 \\ -24 & 0 \end{bmatrix} \mathbf{x} + \begin{bmatrix} 1 \\ 3 \end{bmatrix} r$ $y = [1 \quad 0] \mathbf{x}$

# UNIT-III

## TIME RESPONSE ANALYSIS

# Transient vs Steady-State

The output of any differential equation can be broken up into two parts,

- a **transient part** (which decays to zero as  $t$  goes to infinity) and
- a **steady-state part** (which does not decay to zero as  $t$  goes to infinity).

$$y(t) = y_{tr}(t) + y_{ss}(t)$$

$$\lim_{t \rightarrow \infty} y_{tr}(t) = 0$$

Either part might be zero in any particular case.



# Prototype systems

1<sup>st</sup> Order system

$$\dot{c}(t) + \frac{1}{\tau} c(t) = kr(t)$$

2<sup>nd</sup> order system

$$\ddot{c}(t) + 2\zeta\omega_n\dot{c}(t) + \omega_n^2 c(t) = kr(t)$$

Agenda:

- transfer function

- response to test signals

  - impulse

  - step

  - ramp

  - parabolic

  - sinusoidal

# 1<sup>st</sup> order system

Impulse response

Step response

Ramp response

Relationship between impulse, step and ramp

Relationship between impulse, step and ramp responses

$$G(s) = \frac{C(s)}{R(s)} = \frac{1/T}{s + 1/T}$$

$$r(t) = \delta(t), R(s) = 1, \quad c_{\delta}(t) = \frac{1}{T} e^{-t/T} 1(t)$$

$$r(t) = 1(t), R(s) = \frac{1}{s}, \quad c_{step}(t) = \left[ 1 - e^{-t/T} \right] 1(t)$$

$$r(t) = t1(t), R(s) = \frac{1}{s^2}, \quad c_{ramp}(t) = \left[ t - T + T e^{-t/T} \right] 1(t)$$

# 1<sup>st</sup> Order system

Prototype parameter: Time constant

Relate problem specific parameter to prototype parameter.

Parameters: problem specific constants. Numbers that do not change with time, but do change from problem to problem.

We learn that the time constant defines a problem specific time scale that is more convenient than the arbitrary time scale of seconds, minutes, hours, days, etc, or fractions thereof.

# Transient vs Steady state

Consider the impulse, step, ramp responses computed earlier. Identify the steady state and the transient parts.

# 1<sup>st</sup> order system

Consider the impulse, step, ramp responses computed earlier. Identify the steady state and the transient parts.

Impulse response

Step response

Ramp response

Relationship between impulse, step and ramp

Relationship between impulse, step and ramp responses

$$G(s) = \frac{C(s)}{R(s)} = \frac{1/T}{s + 1/T}, \quad T > 0$$

$$r(t) = \delta(t), R(s) = 1, \quad c_{\delta}(t) = \frac{1}{T} e^{-t/T} \mathbf{1}(t)$$

$$r(t) = \mathbf{1}(t), R(s) = \frac{1}{s}, \quad c_{step}(t) = \left[ 1 - e^{-t/T} \right] \mathbf{1}(t)$$

$$r(t) = t\mathbf{1}(t), R(s) = \frac{1}{s^2}, \quad c_{ramp}(t) = \left[ t - T + Te^{-t/T} \right] \mathbf{1}(t)$$

Compare steady-state part to input function, transient part to TF.

2<sup>nd</sup> order system  $G(s) = \frac{C(s)}{R(s)} = \frac{K\omega_n^2}{s^2 + 2\zeta\omega_n s + \omega_n^2}$

### Over damped

- (two real distinct roots = two 1<sup>st</sup> order systems with real poles)

### Critically damped

- (a single pole of multiplicity two, highly unlikely, requires exact matching)

### Underdamped

- (complex conjugate pair of poles, oscillatory behavior, most common)

step response

$$c_{step}(t) = K \left[ 1 - \frac{e^{-\zeta\omega_n t}}{\sqrt{1-\zeta^2}} \sin \left( \omega_d t + \tan^{-1} \left( \sqrt{1-\zeta^2} / \zeta \right) \right) \right] 1(t)$$

$$c_{\delta}(t) = K \left[ \frac{\omega_n}{\sqrt{1-\zeta^2}} e^{-\zeta\omega_n t} \sin(\omega_d t) \right] 1(t)$$

# 2<sup>nd</sup> Order System

Prototype parameters:

undamped natural frequency,  
damping ratio

Relating problem specific parameters to prototype parameters

# Transient vs Steady state

Consider the step, responses computed earlier. Identify the steady state and the transient parts.



# 2<sup>nd</sup> order system

$$G(s) = \frac{C(s)}{R(s)} = \frac{K\omega_n^2}{s^2 + 2\zeta\omega_n s + \omega_n^2}$$

## Over damped

- (two real distinct roots = two 1<sup>st</sup> order systems with real poles)

## Critically damped

- (a single pole of multiplicity two, highly unlikely, requires exact matching)

## Underdamped

- (complex conjugate pair of poles, oscillatory behavior, most common)

step response

$$c_{step}(t) = K \left[ 1 - \frac{e^{-\zeta\omega_n t}}{\sqrt{1-\zeta^2}} \sin \left( \omega_d t + \tan^{-1} \left( \sqrt{1-\zeta^2} / \zeta \right) \right) \right] 1(t)$$

$$c_{\delta}(t) = K \left[ \frac{\omega_n}{\sqrt{1-\zeta^2}} e^{-\zeta\omega_n t} \sin(\omega_d t) \right] 1(t)$$

# Use of Prototypes

Too many examples to cover them all

We cover important prototypes

We develop intuition on the prototypes

We cover how to convert specific examples to prototypes

We transfer our insight, based on the study of the prototypes to the specific situations.

# Transient-Response Specifications

1. Delay time,  $t_d$ : The time required for the response to reach half the final value the very first time.
2. Rise time,  $t_r$ : the time required for the response to rise from 10% to 90% (common for overdamped and 1<sup>st</sup> order systems); 5% to 95%; or 0% to 100% (common for underdamped systems); of its final value
  1. Peak time,  $t_p$ :
  2. Maximum (percent) overshoot,  $M_p$ :
  3. Settling time,  $t_s$

# Derived relations for 2<sup>nd</sup> Order Systems

$$\omega_d = \omega_n \sqrt{1 - \zeta^2}$$
$$\sigma = \zeta \omega_n$$

$$t_r = \frac{\pi - \beta}{\omega_d} \quad t_p = \frac{\pi}{\omega_d}$$

$$\beta = \tan^{-1} \left( \frac{\omega_d}{\sigma} \right)$$

$$M_p = e^{-\frac{\zeta \pi}{\sqrt{1 - \zeta^2}}} \times 100\%$$

See book for details. (Pg. 232)

$$t_s = 4T = \frac{4}{\sigma} = \frac{4}{\zeta \omega_n} \quad 2\% \quad t_s = 3T = \frac{3}{\sigma} = \frac{3}{\zeta \omega_n} \quad 5\%$$

**Allowable  $M_p$  determines damping ratio.**

**Settling time then determines undamped natural frequency.**

**Theory is used to derive relationships between design specifications and prototype parameters.**

Which are related to problem parameters.

# Higher order system

PFEs have linear denominators.

- each term with a real pole has a time constant
- each complex conjugate pair of poles has a damping ratio and an undamped natural frequency.

# Proportional control of plant w integrator

$$G_C(s) = K_p, \quad G(s) = \frac{1}{s(Js + b)}$$

# Integral control of Plant w disturbance

$$G_C(s) = \frac{K}{s}, \quad G(s) = \frac{1}{s(Js + b)}$$

# Proportional Control of plant w/o integrator

$$G_C(s) = K, \quad G(s) = \frac{1}{Ts + 1}$$



# Integral control of plant w/o integrator

$$G_C(s) = \frac{K}{s}, \quad G(s) = \frac{1}{Ts + 1}$$

# UNIT-IV

## STABILITY ANALYSIS IN S- DOMAIN

# Routh's Stability Criterion

How do we determine stability without finding all poles?

Actual poles provide more info than is needed.

All we need to know if any poles are in LHP.

Routh's stability criterion (Section 5-7).

$$q(s) = s^4 + 2s^3 + 3s^2 + 4s + 5$$

$$q(s) = s^3 + 2s^2 + s + 2$$

$$q(s) = s^5 + 2s^4 + 24s^3 + 48s^2 - 25s - 50$$

What values of K produce a stable system?

$$G(s) = \frac{K}{s(s^2 + s + 1)(s + 2)}, \quad T(s) = \frac{G(s)}{1 + G(s)}$$

## The Stability of Linear Feedback Systems

The issue of ensuring the stability of a closed-loop feedback system is central to control system design. Knowing that an unstable closed-loop system is generally of no practical value, we seek methods to help us analyze and design stable systems. A stable system should exhibit a bounded output if the corresponding input is bounded. This is known as bounded-input, bounded-output stability and is one of the main topics of this chapter.

The stability of a feedback system is directly related to the location of the roots of the characteristic equation of the system transfer function. The Routh–Hurwitz method is introduced as a useful tool for assessing system stability. The technique allows us to compute the number of roots of the characteristic equation in the right half-plane without actually computing the values of the roots. Thus we can determine stability without the added computational burden of determining characteristic root locations. This gives us a design method for determining values of certain system parameters that will lead to closed-loop stability. For stable systems we will introduce the notion of relative stability, which allows us to characterize the degree of stability.

## The Concept of Stability

A stable system is a dynamic system with a bounded response to a bounded input.

Absolute stability is a stable/not stable characterization for a closed-loop feedback system. Given that a system is stable we can further characterize the degree of stability, or the relative stability.

## The Concept of Stability

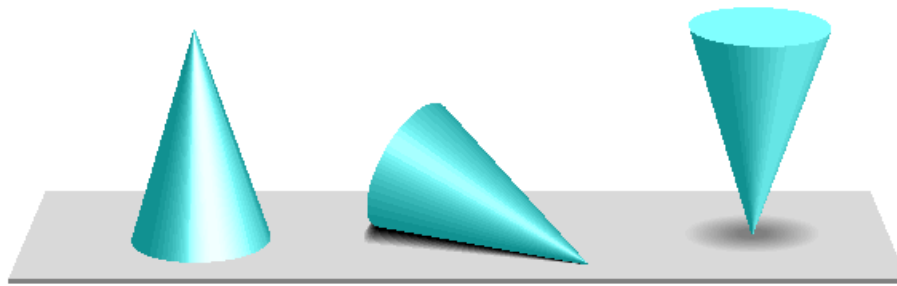

(a) Stable

(b) Neutral

(c) Unstable

The concept of stability can be illustrated by a cone placed on a plane horizontal surface.

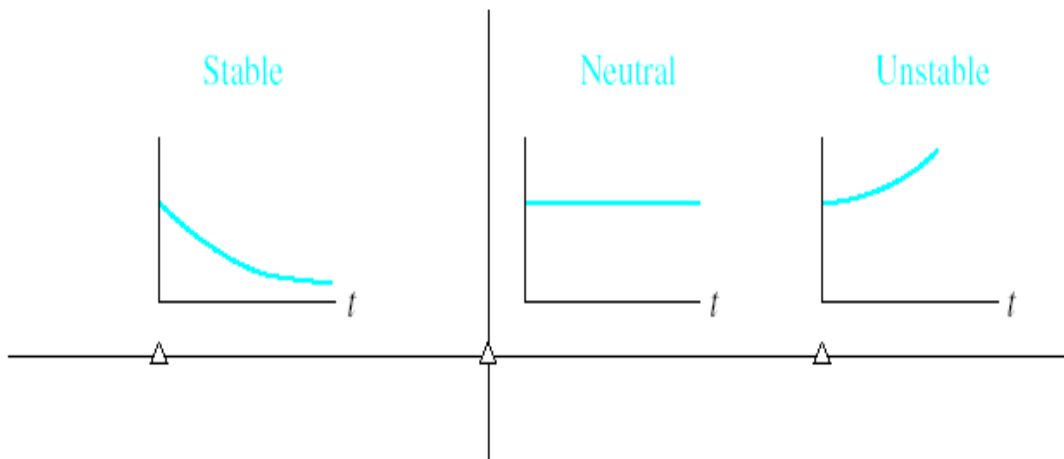

A necessary and sufficient condition for a feedback system to be stable is that all the poles of the system transfer function have negative real parts.

A system is considered marginally stable if only certain bounded inputs will result in a bounded output.

## The Routh-Hurwitz Stability Criterion

It was discovered that all coefficients of the characteristic polynomial must have the same sign and non-zero if all the roots are in the left-hand plane.

These requirements are necessary but not sufficient. If the above requirements are not met, it is known that the system is unstable. But, if the requirements are met, we still must investigate the system further to determine the stability of the system.

The Routh-Hurwitz criterion is a necessary and sufficient criterion for the stability of linear systems.

## The Routh-Hurwitz Stability Criterion

Characteristic equation,  $q(s)$

$$a_n s^n + a_{n-1} s^{n-1} + a_{n-2} s^{n-2} + \dots + a_1 s + a_0 = 0$$

Routh array

$$\begin{array}{c|ccc}
 s^n & a_n & a_{n-2} & a_{n-4} \\
 s^{n-1} & a_{n-1} & a_{n-3} & a_{n-5} \\
 s^{n-2} & b_{n-1} & b_{n-3} & b_{n-5} \\
 s^{n-3} & c_{n-1} & c_{n-3} & c_{n-5} \\
 \bullet & \bullet & \bullet & \bullet \\
 \bullet & \bullet & \bullet & \bullet \\
 \bullet & \bullet & \bullet & \bullet \\
 s^0 & h_{n-1} & & 
 \end{array}$$

The Routh-Hurwitz criterion states that the number of roots of  $q(s)$  with positive real parts is equal to the number of changes in sign of the first column of the Routh array.

$$b_{n-1} = \frac{(a_{n-1})(a_{n-2}) - a_n(a_{n-3})}{a_{n-1}} = \frac{-1}{a_{n-1}} \begin{vmatrix} a_n & a_{n-2} \\ a_{n-1} & a_{n-3} \end{vmatrix}$$

$$b_{n-3} = \frac{-1}{a_{n-1}} \begin{vmatrix} a_{n-2} & a_{n-4} \\ a_{n-1} & a_{n-3} \end{vmatrix}$$

$$c_{n-1} = \frac{-1}{b_{n-1}} \begin{vmatrix} a_{n-1} & a_{n-3} \\ b_{n-1} & b_{n-3} \end{vmatrix}$$



## The Routh-Hurwitz Stability Criterion

**Case One:** No element in the first column is zero.

Example 6.1      Second-order system

The Characteristic polynomial of a second-order system is:

$$q(s) = a_2 \cdot s^2 + a_1 \cdot s + a_0$$

The Routh array is written as:

$$\begin{array}{c|cc} s^2 & a_2 & a_0 \\ s^1 & a_1 & 0 \\ s^0 & b_1 & 0 \end{array}$$

where:

$$b_1 = \frac{a_1 \cdot a_0 - (0) \cdot a_2}{a_1} = a_0$$

Therefore the requirement for a stable second-order system is simply that all coefficients be positive or all the coefficients be negative.

## The Routh-Hurwitz Stability Criterion

**Case Two:** Zeros in the first column while some elements of the row containing a zero in the first column are nonzero.

If only one element in the array is zero, it may be replaced with a small positive number  $\varepsilon$  that is allowed to approach zero after completing the array.

$$q(s) = s^5 + 2s^4 + 2s^3 + 4s^2 + 11s + 10$$

The Routh array is then:

$$\begin{array}{c|ccc} s^5 & 1 & 2 & 11 \\ s^4 & 2 & 4 & 10 \\ s^3 & b_1 & 6 & 0 \\ s^2 & c_1 & 10 & 0 \\ s^1 & d_1 & 0 & 0 \\ s^0 & 10 & 0 & 0 \end{array}$$

where:

$$b_1 = \frac{2 \cdot 2 - 1 \cdot 4}{2} = 0 = \varepsilon \qquad c_1 = \frac{4\varepsilon - 2 \cdot 6}{\varepsilon} = \frac{-12}{\varepsilon} \qquad d_1 = \frac{6 \cdot c_1 - 10\varepsilon}{c_1} = 6$$

There are two sign changes in the first column due to the large negative number calculated for  $c_1$ . Thus, the system is unstable because two roots lie in the right half of the plane.

## The Routh-Hurwitz Stability Criterion

**Case Three:** Zeros in the first column, and the other elements of the row containing the zero are also zero.

This case occurs when the polynomial  $q(s)$  has zeros located symmetrically about the origin of the  $s$ -plane, such as  $(s+\sigma)(s-\sigma)$  or  $(s+j\omega)(s-j\omega)$ . This case is solved using the auxiliary polynomial,  $U(s)$ , which is located in the row above the row containing the zero entry in the Routh array.

$$q(s) = s^3 + 2s^2 + 4s + K$$

$$\text{Routh array: } \begin{array}{c|cc} s^3 & 1 & 4 \\ s^2 & 2 & K \\ s^1 & \frac{8-K}{2} & 0 \\ s^0 & K & 0 \end{array}$$

For a stable system we require that  $0 < s < 8$

For the marginally stable case,  $K=8$ , the  $s^1$  row of the Routh array contains all zeros. The auxiliary polynomial comes from the  $s^2$  row.

$$U(s) = 2s^2 + Ks^0 = 2s^2 + 8 = 2(s^2 + 4) = 2(s + j\cdot 2)(s - j\cdot 2)$$

It can be proven that  $U(s)$  is a factor of the characteristic polynomial:

$$\frac{q(s)}{U(s)} = \frac{s + 2}{2}$$

Thus, when  $K=8$ , the factors of the characteristic polynomial are:

$$q(s) = (s + 2)(s + j\cdot 2)(s - j\cdot 2)$$

## The Routh-Hurwitz Stability Criterion

**Case Four:** Repeated roots of the characteristic equation on the  $j\omega$ -axis.

With simple roots on the  $j\omega$ -axis, the system will have a marginally stable behavior. This is not the case if the roots are repeated. Repeated roots on the  $j\omega$ -axis will cause the system to be unstable. Unfortunately, the routh-array will fail to reveal this instability.

## Example 6.4

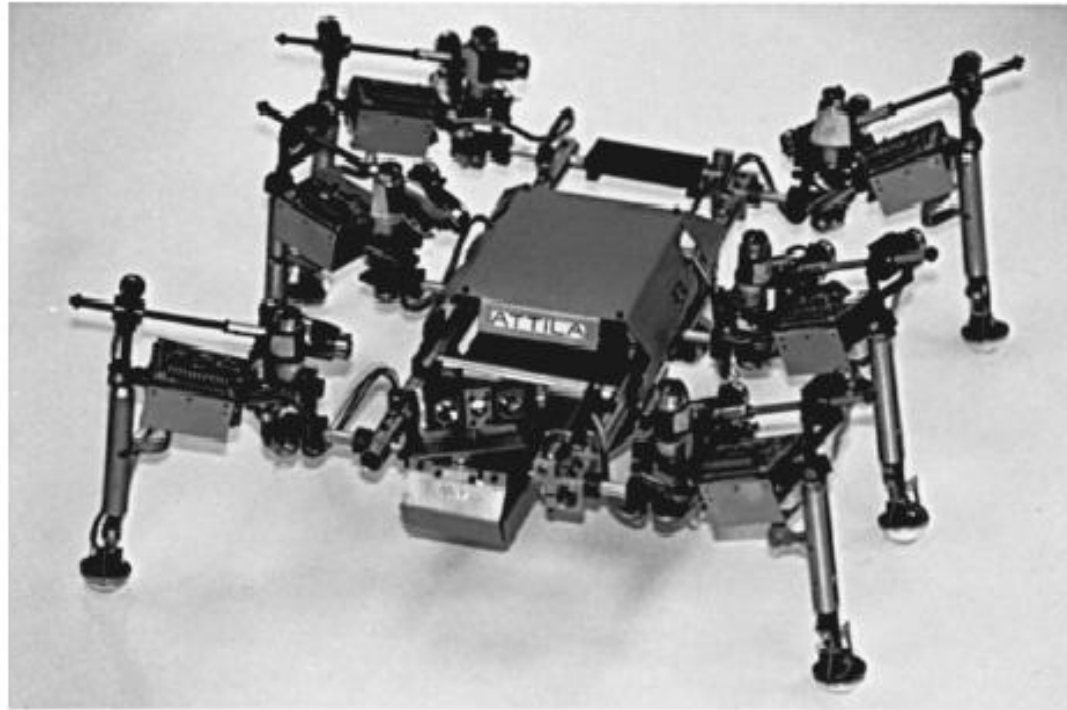

A completely integrated, six-legged, micro robot system. The six-legged design provides maximum dexterity. Legs also provide a unique sensory system for environmental interaction. It is equipped with a sensor network that includes 150 sensors of 12 different types. The legs are instrumented so that the robot can determine the lay of the terrain, the surface texture, hardness, and even color. The gyro-stabilized camera and range finder can be used for gathering data beyond the robot's immediate reach. This high-performance system is able to walk quickly, climb over obstacles, and perform dynamic motions. (Courtesy of IS Robotics Corporation.)

## Example 6.5 Welding control

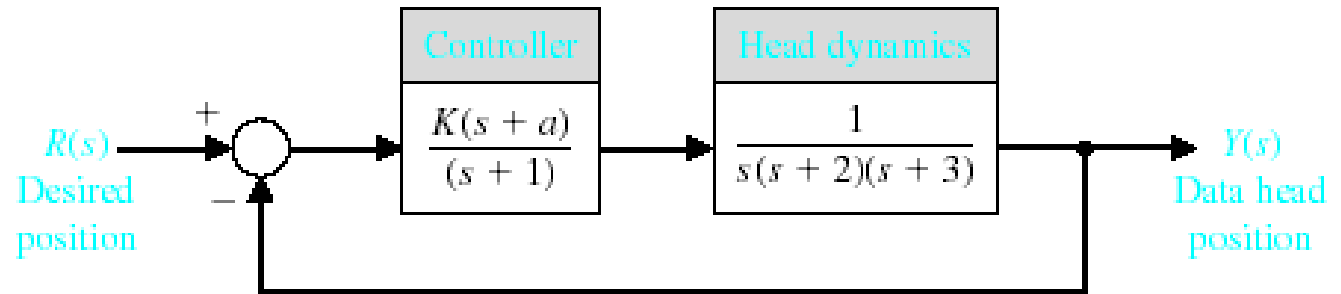

### Welding head position control.

Using block diagram reduction we find that:  $q(s) = s^4 + 6s^3 + 11s^2 + (K + 6)s + Ka$

The Routh array is then:

$$\begin{array}{c|ccc}
 s^4 & 1 & 11 & Ka \\
 s^3 & 6 & (K+6) & \\
 s^2 & b_3 & Ka & \\
 s^1 & c_3 & & \\
 s^0 & Ka & & 
 \end{array}$$

$$\text{where: } b_3 = \frac{60 - K}{6} \quad \text{and} \quad c_3 = \frac{b_3(K + 6) - 6 \cdot Ka}{b_3}$$

For the system to be stable both  $b_3$  and  $c_3$  must be positive.

Using these equations a relationship can be determined for  $K$  and  $a$ .

## The Relative Stability of Feedback Control Systems

It is often necessary to know the relative damping of each root to the characteristic equation. Relative system stability can be measured by observing the relative real part of each root. In this diagram  $r_2$  is relatively more stable than the pair of roots labeled  $r_1$ .

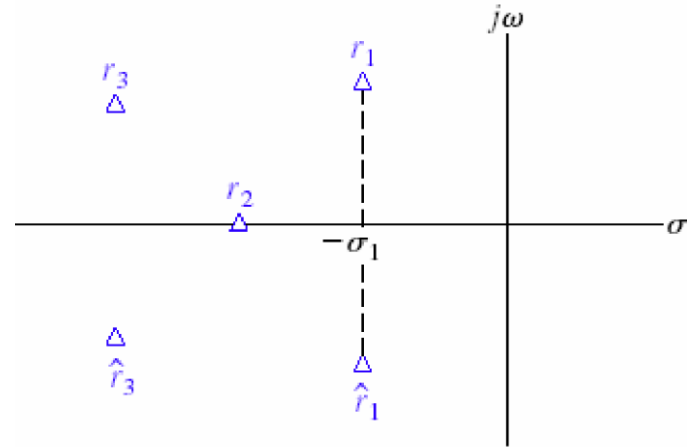

One method of determining the relative stability of each root is to use an axis shift in the  $s$ -domain and then use the Routh array as shown in Example 6.6 of the text.

## Design Example: Tracked Vehicle Turning Control

Problem statement: Design the turning control for a tracked vehicle. Select  $K$  and  $a$  so that the system is stable. The system is modeled below.

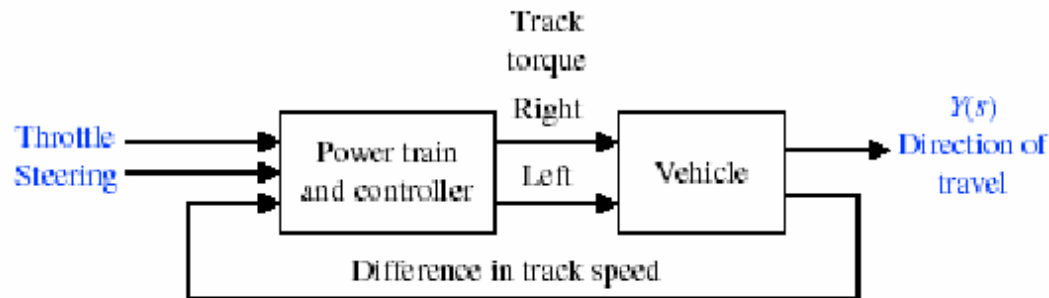

(a)

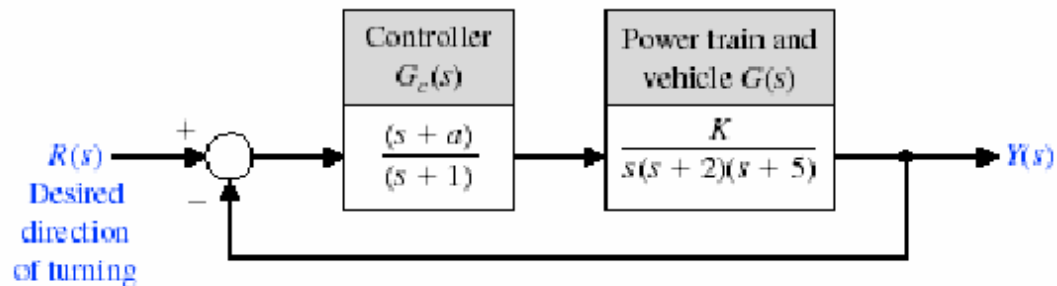

(b)



## Design Example: Tracked Vehicle Turning Control

The characteristic equation of this system is:

$$1 + G_c \cdot G(s) = 0$$

or

$$1 + \frac{K(s + a)}{s(s + 1)(s + 2)(s + 5)} = 0$$

Thus,

$$s(s + 1)(s + 2)(s + 5) + K(s + a) = 0$$

or

$$s^4 + 8s^3 + 17s^2 + (K + 10)s + Ka = 0$$

To determine a stable region for the system, we establish the Routh array as:

$$\begin{array}{c|ccc} s^4 & 1 & 17 & Ka \\ s^3 & 8 & (K + 10) & 0 \\ s^2 & b_3 & Ka & \\ s^1 & c_3 & & \\ s^0 & Ka & & \end{array}$$

where

$$b_3 = \frac{126 - K}{8} \quad \text{and} \quad c_3 = \frac{b_3(K + 10) - 8Ka}{b_3}$$

# Design Example: Tracked Vehicle Turning Control

$$\begin{array}{c|ccc}
 s^4 & 1 & 17 & Ka \\
 s^3 & 8 & (K+10) & 0 \\
 s^2 & b_3 & Ka & \\
 s^1 & c_3 & & \\
 s^0 & Ka & & 
 \end{array}$$

where

$$b_3 = \frac{126 - K}{8} \quad \text{and} \quad c_3 = \frac{b_3(K + 10) - 8Ka}{b_3}$$

Therefore,

$$K < 126$$

$$K \cdot a > 0$$

$$(K + 10)(126 - K) - 64Ka > 0$$

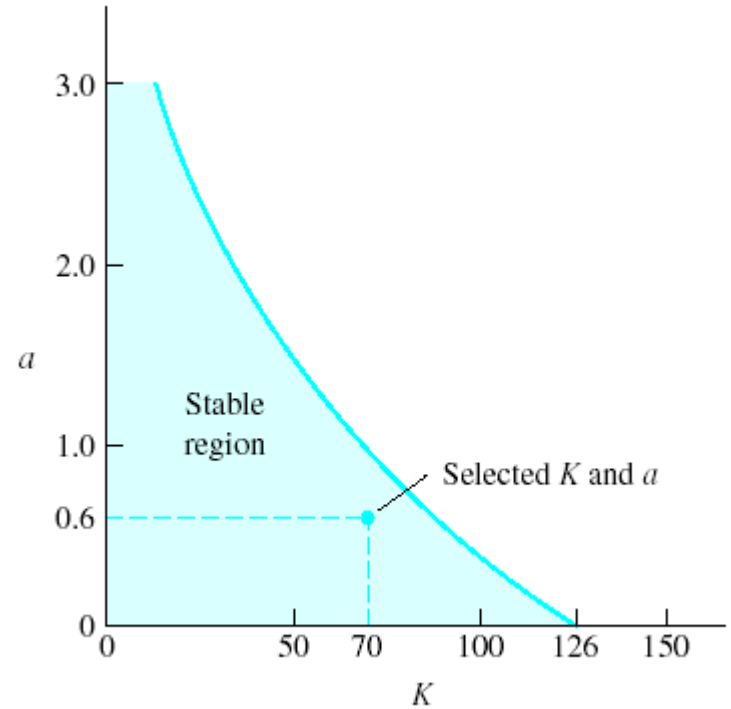

# System Stability Using MATLAB

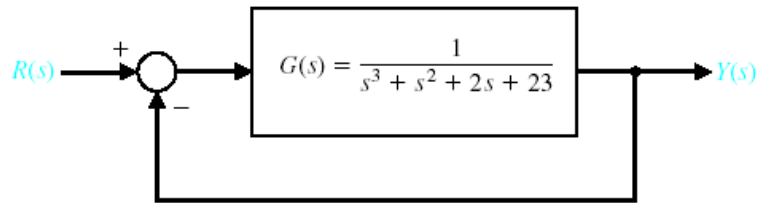

Closed-loop control system with  $T(s) = Y(s)/R(s) = 1/(s^3 + s^2 + 2s + 23)$

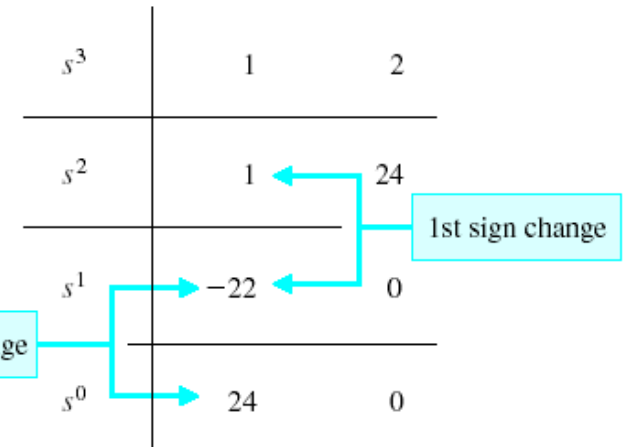

```
>>numg=[1]; deng=[1 1 2 23]; sysg=tf(numg,deng);
>>sys=feedback(sysg,[1]);
>>pole(sys)
```

ans =

-3.0000

1.0000 + 2.6458i

1.0000 - 2.6458i

Unstable poles

# System Stability Using MATLAB

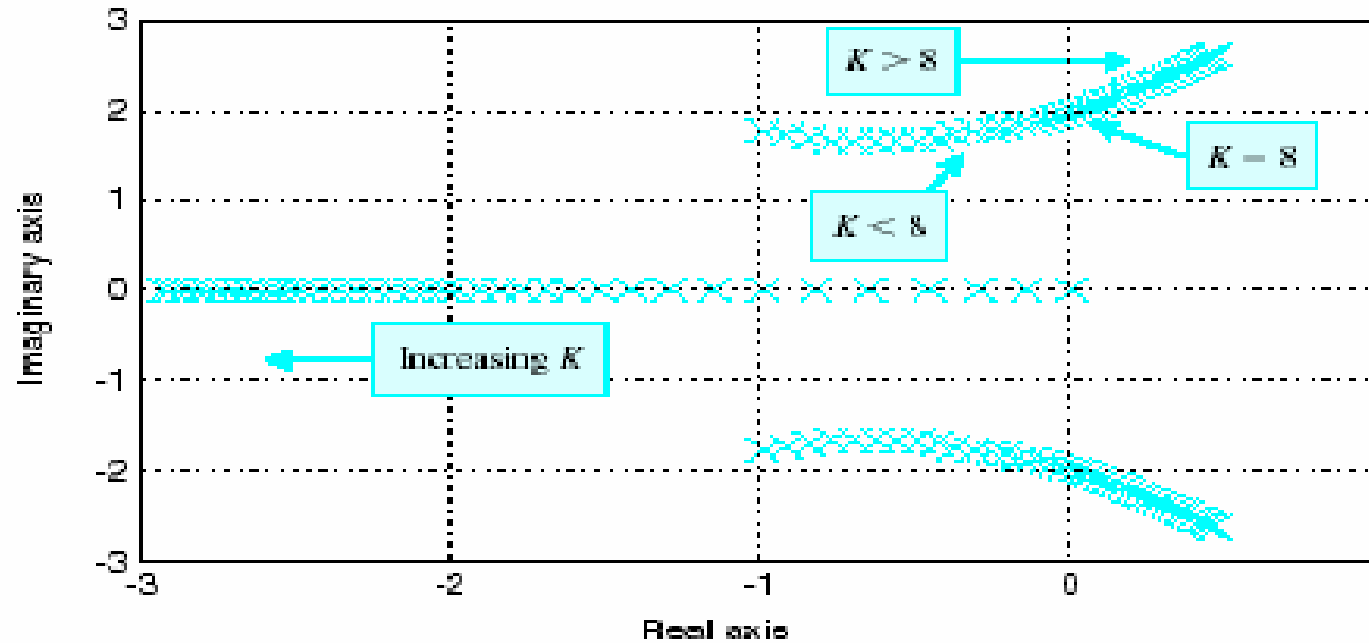
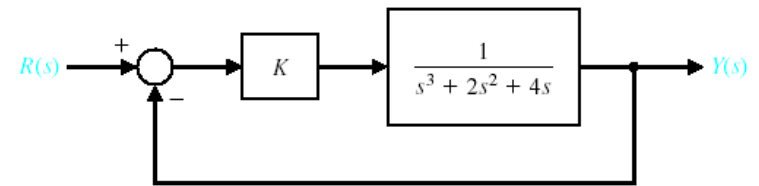

(a)

```
% This script computes the roots of the characteristic
% equation q(s) = s^3 + 2 s^2 + 4 s + K for 0 < K < 20
%
K=[0:0.5:20];
for i=1:length(K)
    q=[1 2 4 K(i)];
    p(:,i)=roots(q);
end
plot(real(p),imag(p),'x'), grid
xlabel('Real axis'), ylabel('Imaginary axis')
```

Loop for roots as a function of K

(b)

# System Stability Using MATLAB

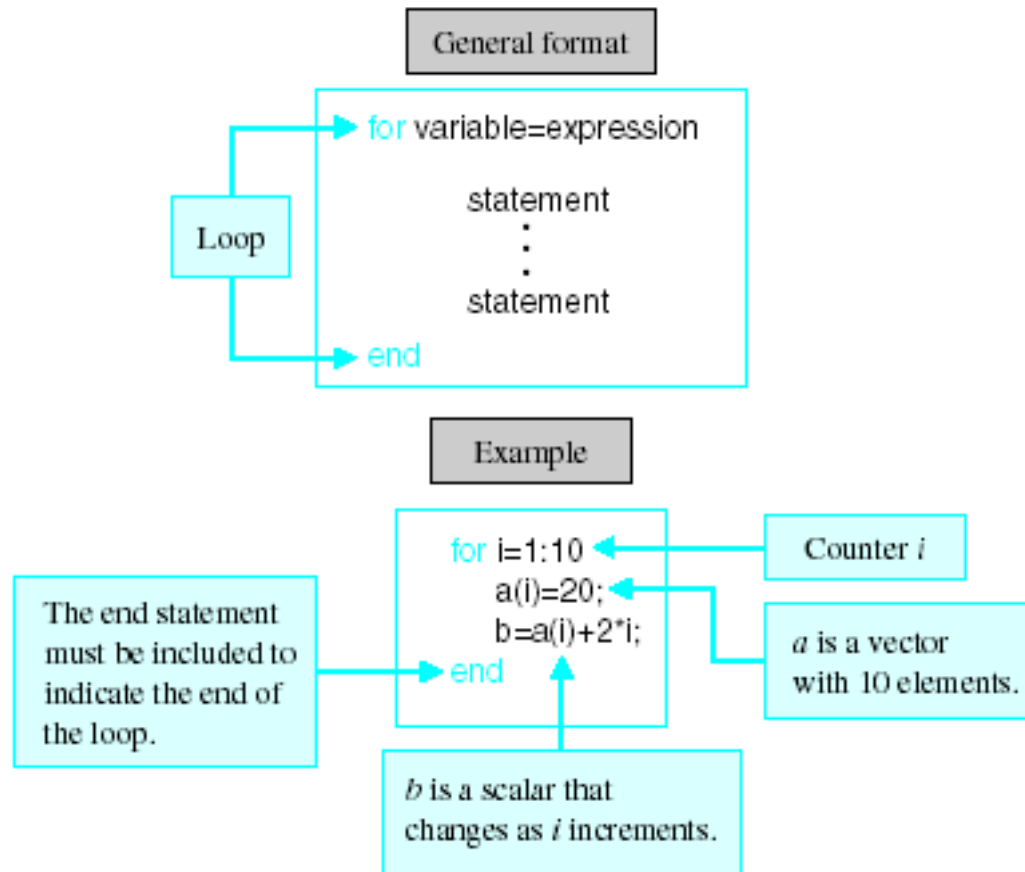

The for function and an illustrative example.

# System Stability Using MATLAB

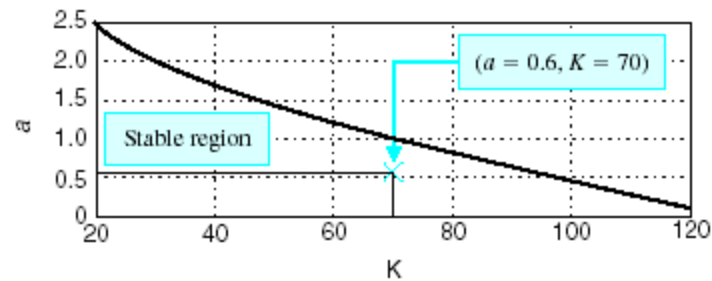

(a)

twotrackstable.m

```

% The a-K stability region for the two track vehicle
% control problem
%
a=[0.1:0.01:3.0]; K=[20:1:120];
x=0*K; y=0*K;
n=length(K); m=length(a);
for i=1:n
    for j=1:m
        q=[1, 8, 17, K(i)+10, K(i)*a(j)];
        p=roots(q);
        if max(real(p)) > 0, x(i)=K(i); y(i)=a(j-1); break; end
    end
end
plot(x,y), grid, xlabel('K'), ylabel('a')
    
```

(b)

(a) Stability region for  $a$  and  $K$  for two-track vehicle turning control.

(b) MATLAB script.

# Root Locus

## •Motivation

To satisfy transient performance requirements, it may be necessary to know how to choose certain controller parameters so that the resulting closed-loop poles are in the performance regions, which can be solved with Root Locus technique.

## •Definition

A graph displaying the roots of a polynomial equation when one of the parameters in the coefficients of the equation changes from 0 to  $\infty$ .

## •Rules for Sketching Root Locus

## •Examples

## •Controller Design Using Root Locus

Letting the CL characteristic equation (CLCE) be the polynomial equation, one can use the Root Locus technique to find how a positive controller design parameter affects the resulting CL poles, from which one can choose a right value for the controller parameter.

# Poles and zeros

$$F(s) = \frac{k(s - z_1)(s - z_2) \cdots (s - z_m)}{(s - p_1)(s - p_2) \cdots (s - p_n)}$$

$z_1, z_2, \dots, z_m$

$p_1, p_2, \dots, p_n$



zeros  
poles

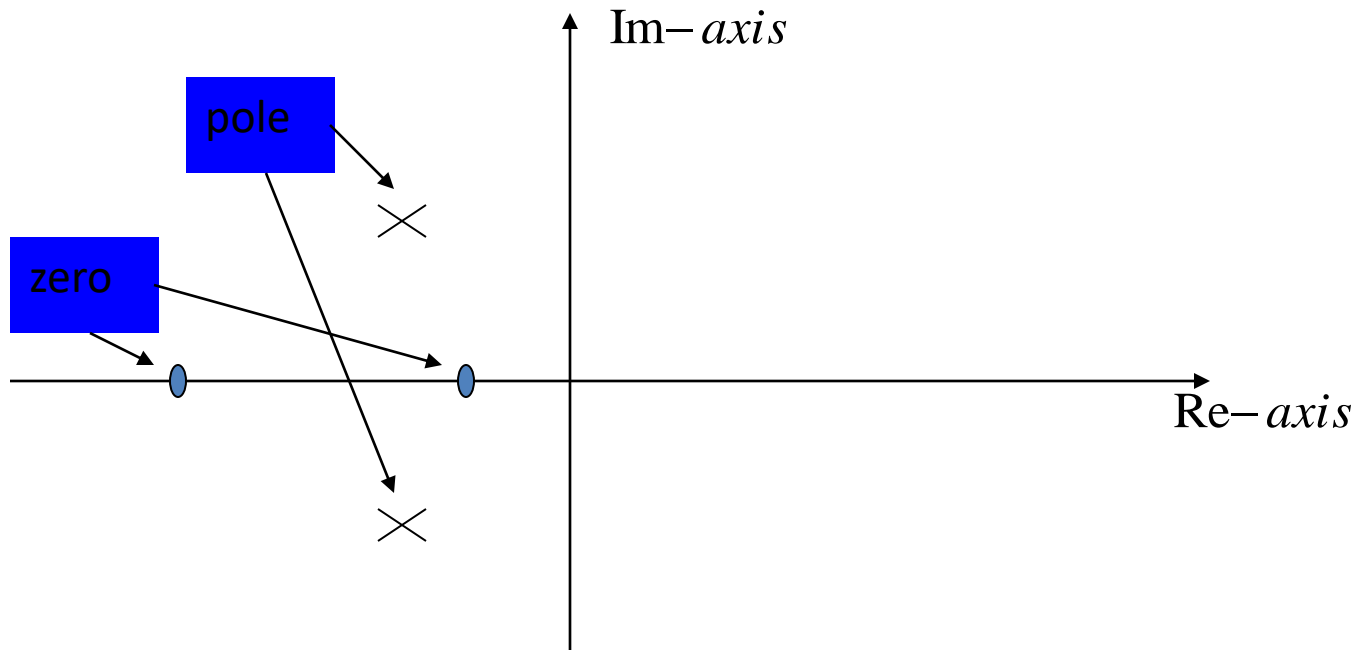



Closed-loop transfer function :

$$T(s) = \frac{\omega_n^2}{s^2 + 2\zeta\omega_n s + \omega_n^2}$$

$$y(t) = 1 - \frac{e^{-\xi\omega_n t}}{\sqrt{1-\xi^2}} \sin(\omega_n \sqrt{1-\xi^2} t + \cos^{-1} \xi)$$

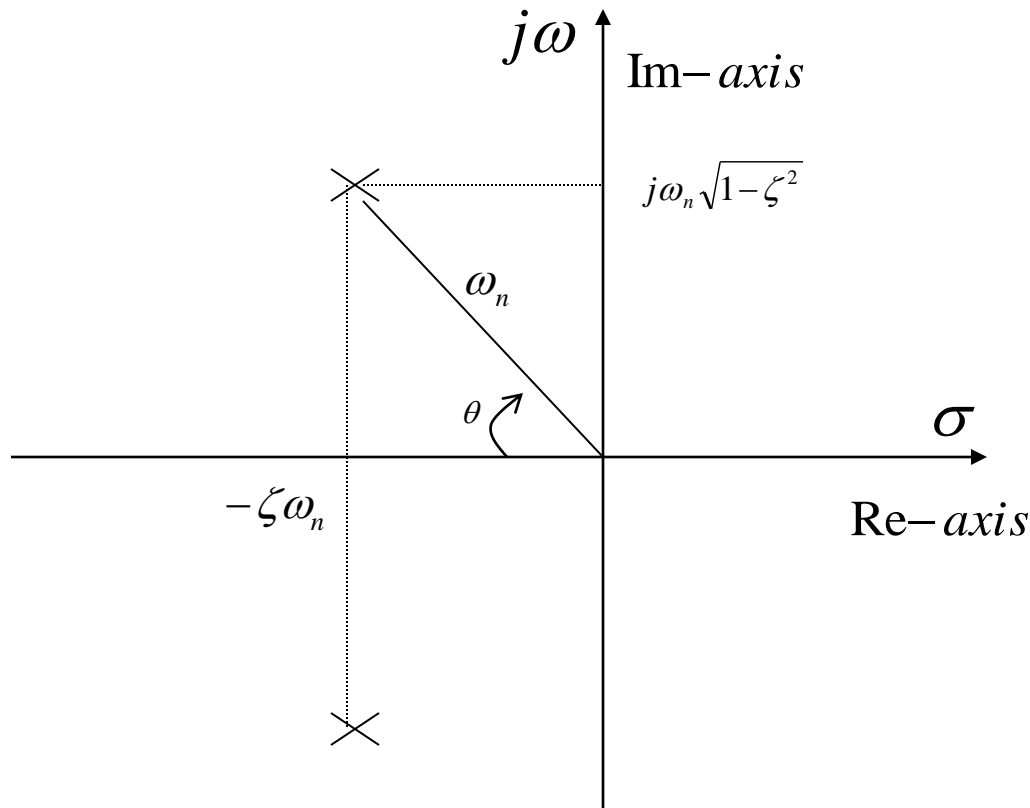

$$\cos \theta = \zeta$$

$$T_p = \frac{\pi}{\omega_n \sqrt{1-\zeta^2}}$$

$$T_s = \frac{4}{\zeta\omega_n}$$

$$m.o. = e^{\frac{-\zeta\pi}{\sqrt{1-\zeta^2}}} \times 100\%$$

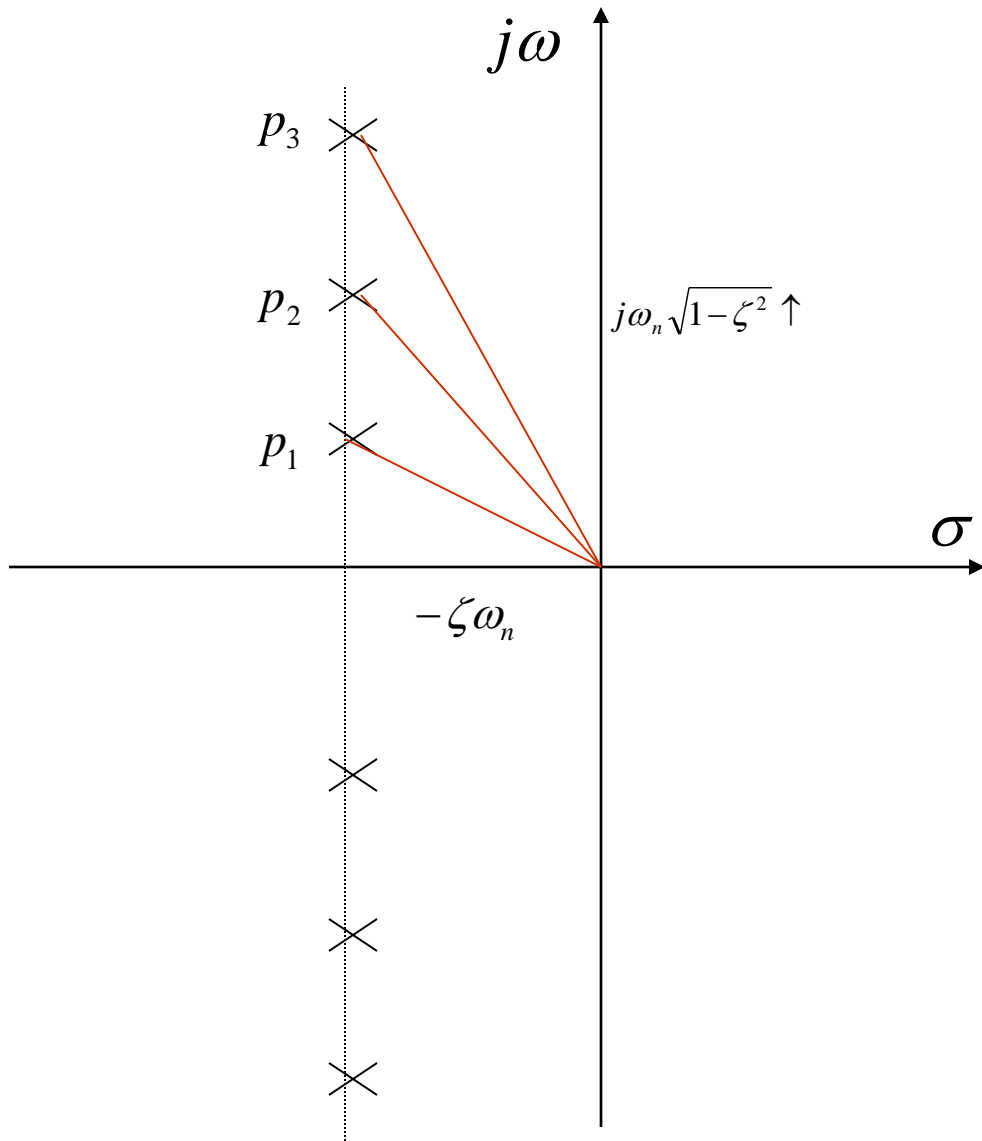

$$\theta_1 < \theta_2 < \theta_3$$

$$\Rightarrow \zeta_1 > \zeta_2 > \zeta_3$$

$$\Rightarrow T_{p1} > T_{p2} > T_{p3}$$

$$\Rightarrow O.S._1 < O.S._2 < O.S._3$$

$$\omega_{n3} > \omega_{n2} > \omega_{n1}$$

$$\Rightarrow T_{s1} = T_{s2} = T_{s3}$$

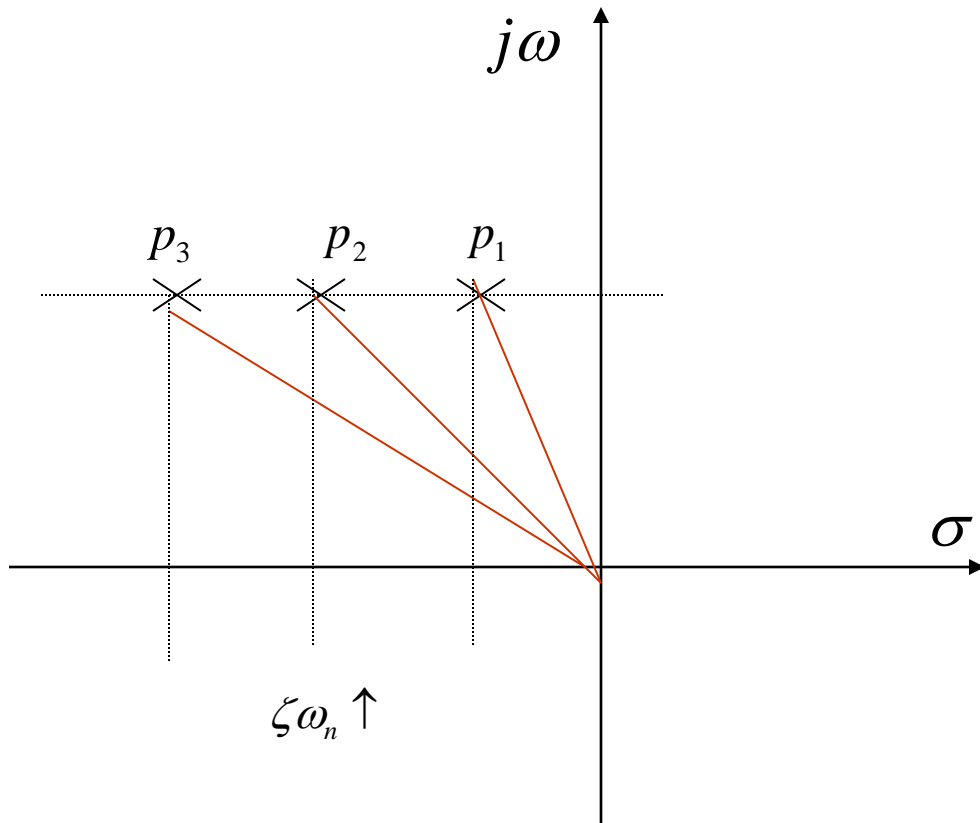

$$\theta_1 \succ \theta_2 \succ \theta_3$$

$$\Rightarrow \zeta_1 \prec \zeta_2 \prec \zeta_3$$

$$\Rightarrow o.s._1 \succ o.s._2 \succ o.s._3$$

$$\Rightarrow T_{p1} = T_{p2} = T_{p3}$$

$$\omega_{n3} \succ \omega_{n2} \succ \omega_{n1}$$

$$\Rightarrow T_{s1} \prec T_{s2} \prec T_{s3}$$

$$(i) \zeta \omega_n \uparrow \Rightarrow T_s \downarrow$$

$$(ii) \omega_n \sqrt{1 - \zeta^2} \uparrow \Rightarrow T_p \uparrow$$

$$(iii) \theta \downarrow \Rightarrow \zeta \uparrow \Rightarrow o.s. \downarrow$$

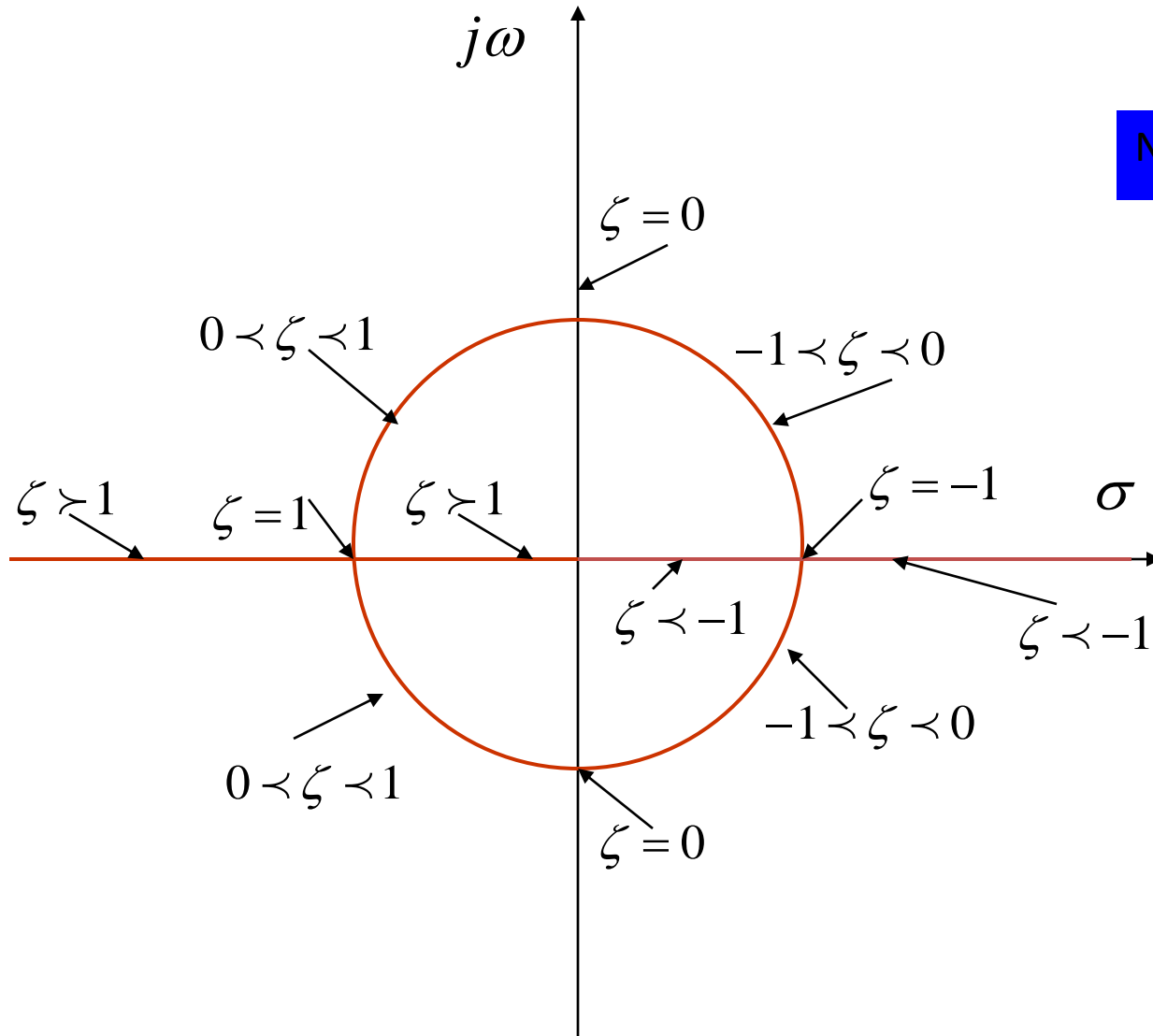

$$\zeta < 0$$

Negative damped

$$\zeta = 0$$

Undamped

$$0 < \zeta < 1$$

Underdamped

$$\zeta = 1$$

Critically damped

$$\zeta > 1$$

Overdamped

# Root locus

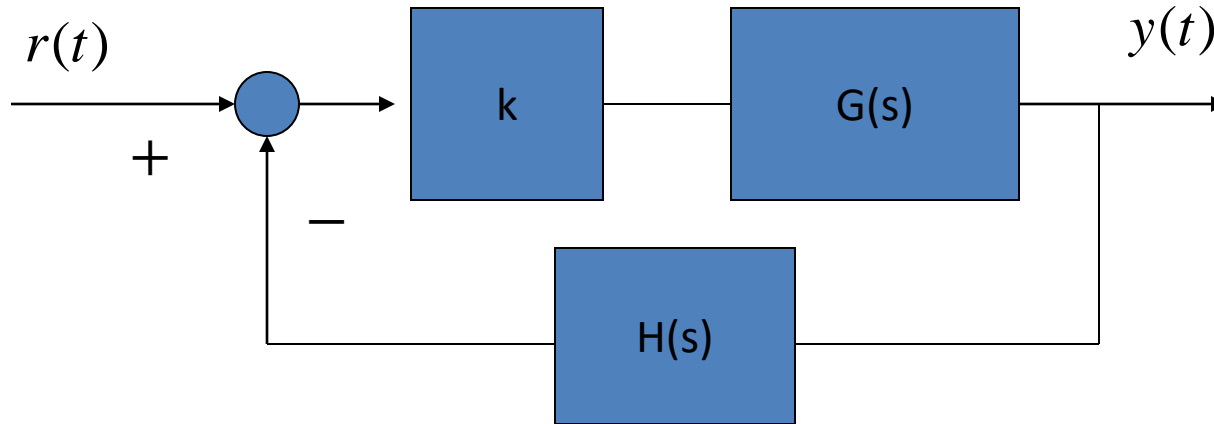

$$T(s) = \frac{y(s)}{R(s)} = \frac{kG(s)}{1 + kG(s)H(s)}$$

$$1 + kG(s)H(s) = 0 \quad \longrightarrow$$

poles

$$1 + kG(s)H(s) = 0$$

Open loop transfer function

$$\Rightarrow kG(s)H(s) = -1$$

$$\Rightarrow |kG(s)H(s)| = 1$$

$$\Rightarrow \angle kG(s)H(s) = (2n + 1)\pi$$

*Using open loop transfer function + system parameters to analyze the closed-loop system response*

$$k = 0 \rightarrow \infty$$

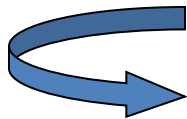

Draw the s-plan root locus

Root locus properties:

(i) The locus segments are symmetrical about the real axis.

(ii)

$$k = \frac{1}{|G(s)H(s)|}, k = 0 \rightarrow \infty$$

$k = 0, G(s)H(s) \Rightarrow$  poles

(iii)

$k \rightarrow \infty, G(s)H(s) \Rightarrow$  zeros

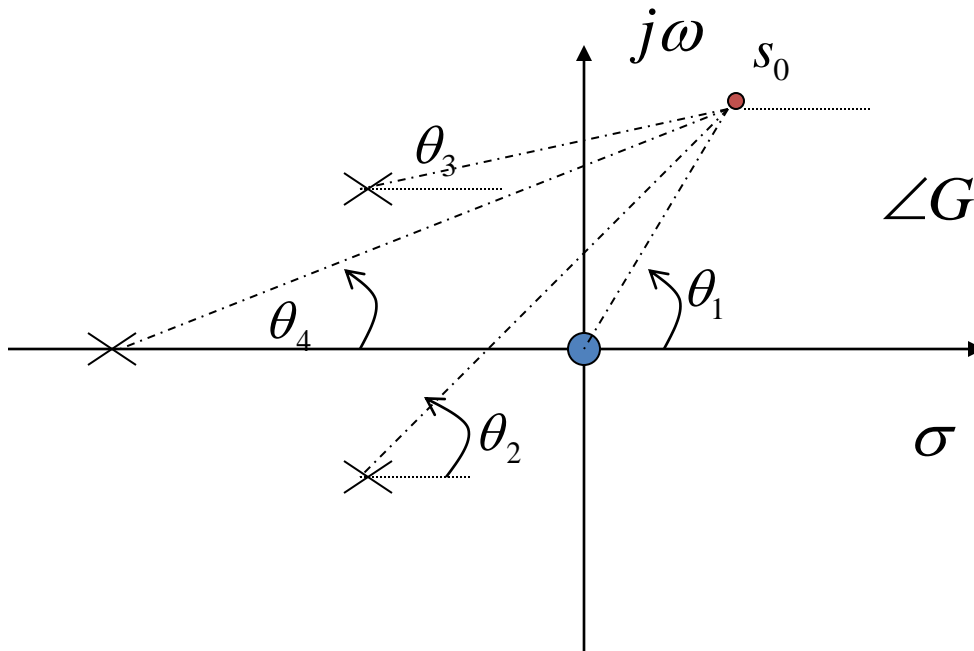

$$\angle G(s_0)H(s_0) = \theta_1 - (\theta_2 + \theta_3 + \theta_4)$$

## Root locus construction

### (i) Loci Branches

each locus from poles to ~~zeros~~  $k \rightarrow \infty$

if  $n \neq m$  for excess zeros or poles, locus segments extend from infinity.

$$(1) \quad n - m > 0$$

$n - m$  branches  $\rightarrow \infty$

$$(2) \quad n - m < 0$$

$m - n$  branches  $\infty \rightarrow$  zeros



(ii) Real axis segments

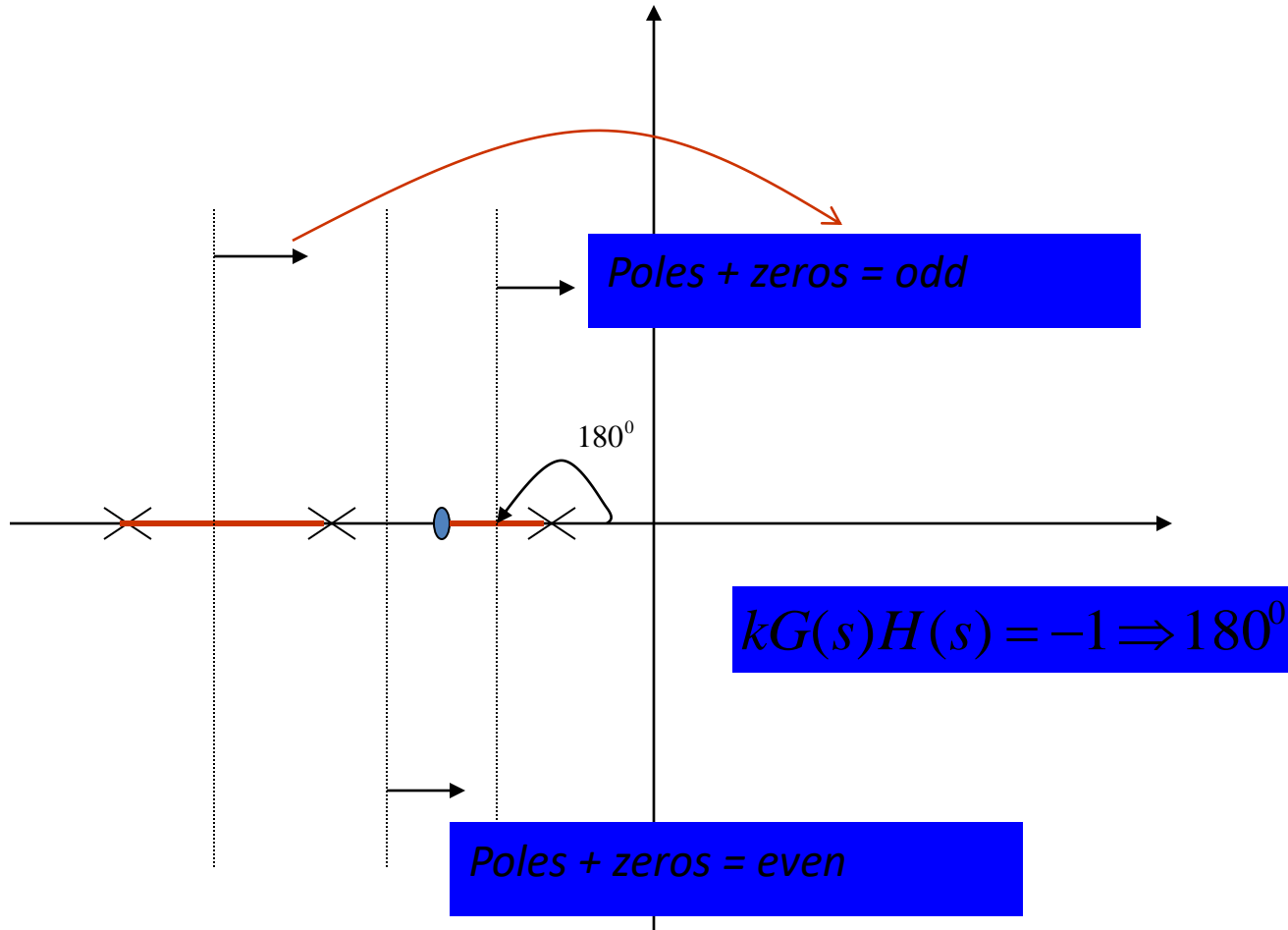

(iii) Asymptotic angles

$$\theta_k = \frac{(2k+1)\pi}{n-m}, k = 0, 1, 2, \dots$$

if  $n = 6, m = 2$   $\theta = \frac{180}{4} = 45^\circ$

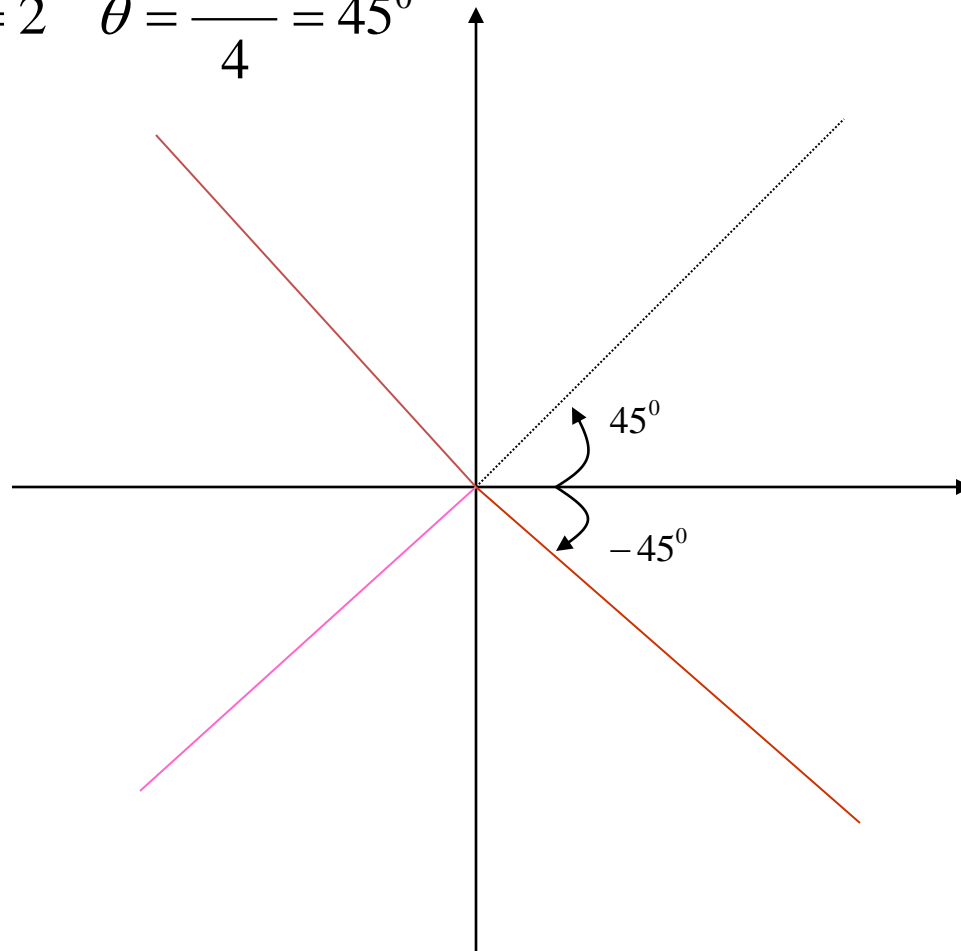

(iv) Centroid of the asymptotes

$$\sigma = \frac{\sum \text{poles} - \sum \text{zeros}}{n - m}$$

example

$$G(s)H(s) = \frac{3s}{(s+2)(s^2+6s+18)}$$

Zero : 0

Poles: -2, -3+j3, -3-j3

$$\sigma = \frac{(-2-3+j3-3-j3)-0}{3-1} = -4$$

$$\theta = \frac{180}{3-1} = 90^\circ$$

(v) Breakaway and entry points

$$\frac{dk}{ds} = 0$$

example  $kGH = \frac{k}{s(s+1)(s+2)}$

$$1 + kGH = 0$$

The characteristic function of closed loop system

$$1 + kGH = \frac{s^3 + 3s^2 + 2s + k}{s(s+1)(s+2)} = 0$$

$$k = -(s^3 + 3s^2 + 2s)$$

$$\frac{dk}{ds} = -3s^2 + 6s + 2 = 0$$

$$s = -0.423, -1.577$$

(vi) Angle of departure and approach

$$\phi_D = 180^\circ + \angle G(s)H(s)$$

$$\phi_A = 180^\circ - \angle G(s)H(s)$$

example  $kGH = \frac{k(s+2)}{(s+1+j)(s+1-j)}$

Angle of departure from the pole:  $s = -1 - j$

$$\angle(s+2) - \angle(s+1+j) - \angle(s+1-j) = -180^\circ$$

$$\angle(s+2) - \phi_D - \angle(s+1-j) = -180^\circ$$

$$\angle(-1-j+2) - \phi_D - \angle(-1-j+1-j) = -180^\circ$$

$$\phi_D = 180 + \angle(-1-j+2) - \angle(-1-j+1-j)$$

$$\phi_D = 225^\circ$$

example  $kGH = \frac{k(s+j)(s-j)}{s(s+1)}$

Angle of approach to the zero:  $s = j$

$$\angle(s+j) + \angle(s-j) - \angle s - \angle(s+1) = -180^0$$

$$\angle(s+j) + \phi_A - \angle s - \angle(s+1) = -180^0$$

$$\angle(j+j) + \phi_A - \angle j - \angle(j+1) = -180^0$$

$$\phi_A = -180^0 - \angle(j+j) + \angle j + \angle(j+1)$$

$$\phi_A = -135^0$$

(vii) The cross point of root locus and Im-axis

example  $kGH = \frac{k}{s(s+3)(s^2+2s+2)}$

The characteristic function of closed loop system:

$$s(s+3)(s^2+2s+2) + k = 0$$

$$s^4 + 5s^3 + 8s^2 + 6s + k = 0$$

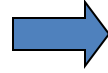

$$\frac{204 - 25k}{34} = 0$$

$$k = 8.16$$

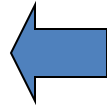

$$\frac{34}{5}s^2 + k = 0$$

$$s = \pm j1.095$$

$s^4$	1	8	$k$
$s^3$	5	6	
$s^2$	$\frac{34}{5}$	$k$	
$s^1$	$\frac{204 - 25k}{34}$		
$s^0$	$k$		

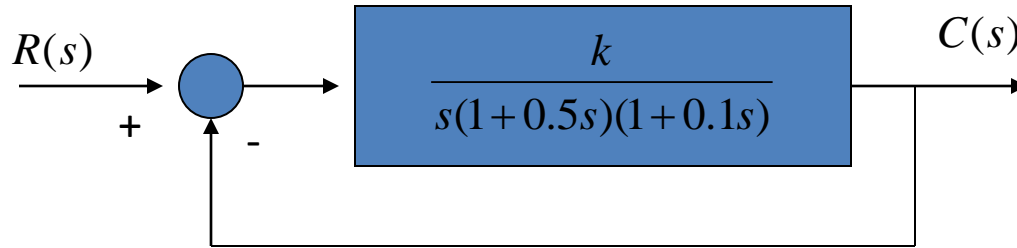

$$kGH(s) = \frac{k}{s(1+0.5s)(1+0.1s)}$$

(i) *poles* = 0, -2, -10  
*zeros* =  $\infty$ ,  $\infty$ ,  $\infty$

$$s(1+0.5s)(1+0.1s) + k = 0$$

$$0.05s^3 + 0.6s^2 + s + k = 0$$

(iii)

$$\frac{dk}{ds} = -\frac{d}{ds}(0.05s^3 + 0.6s^2 + s) = 0$$

$$s_1 = -0.945, s_2 = -7.05$$

(ii) 
$$\sigma = \frac{0 + (-2) + (-10) - 0}{3 - 0} = -4$$

$$\theta_k = \frac{180}{3 - 0} = 60$$



$$0.05s^3 + 0.6s^2 + s + k = 0$$

$s^3$	0.05	1
$s^2$	0.6	$k$
$s^1$	$0.6 - 0.05k$	
$s$	$k$	



$$k = 12$$

$$0.6s^2 + 12 = 0$$

$$s = \pm j4.5$$

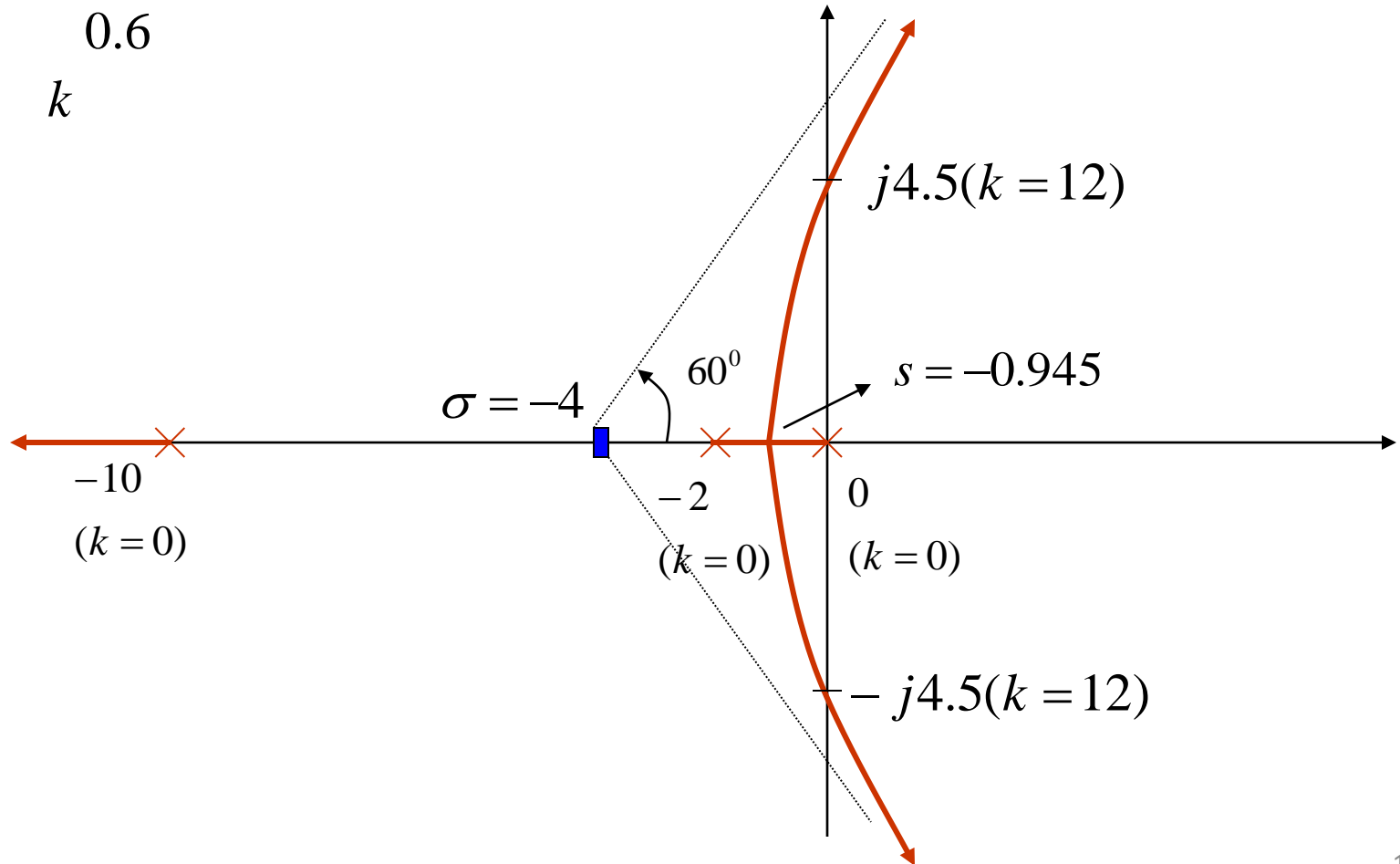

## MATLAB method

$$kGH(s) = \frac{k}{s(1+0.5s)(1+0.1s)}$$

```
gh=zpk([], [0 -2 -10], [1])  
rltool(gh)
```

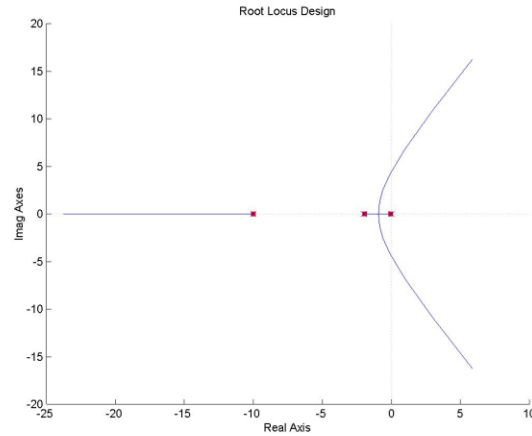

$$kGH(s) = \frac{k(-3s-9)}{s^4 - s^3 - s^2 - 15s}$$

```
n=[-3 -9]  
m=[1 -1 -1 -15 0]  
gh=tf(n,m)  
rltool(gh)
```

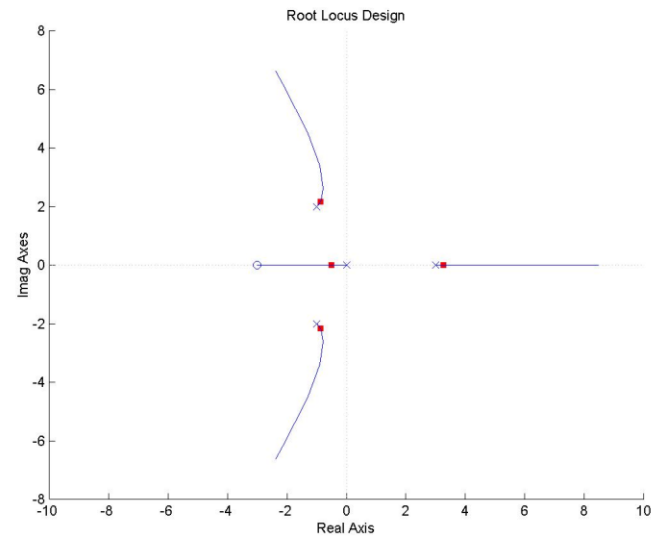

# UNIT-V

## BODE PLOT

# Poles and Zeros and Transfer Functions

## Transfer Function:

A transfer function is defined as the ratio of the Laplace transform of the output to the input with all initial conditions equal to zero. Transfer functions are defined only for linear time invariant systems.

## Considerations:

Transfer functions can usually be expressed as the ratio of two polynomials in the complex variable,  $s$ .

## Factorization:

A transfer function can be factored into the following form.

$$G(s) = \frac{K(s + z_1)(s + z_2) \dots (s + z_m)}{(s + p_1)(s + p_2) \dots (s + p_n)}$$

***The roots of the numerator polynomial are called zeros.***

***The roots of the denominator polynomial are called poles.***

# Poles, Zeros and the S-Plane

## An Example:

You are given the following transfer function. Show the poles and zeros in the s-plane.

$$G(s) = \frac{(s + 8)(s + 14)}{s(s + 4)(s + 10)}$$

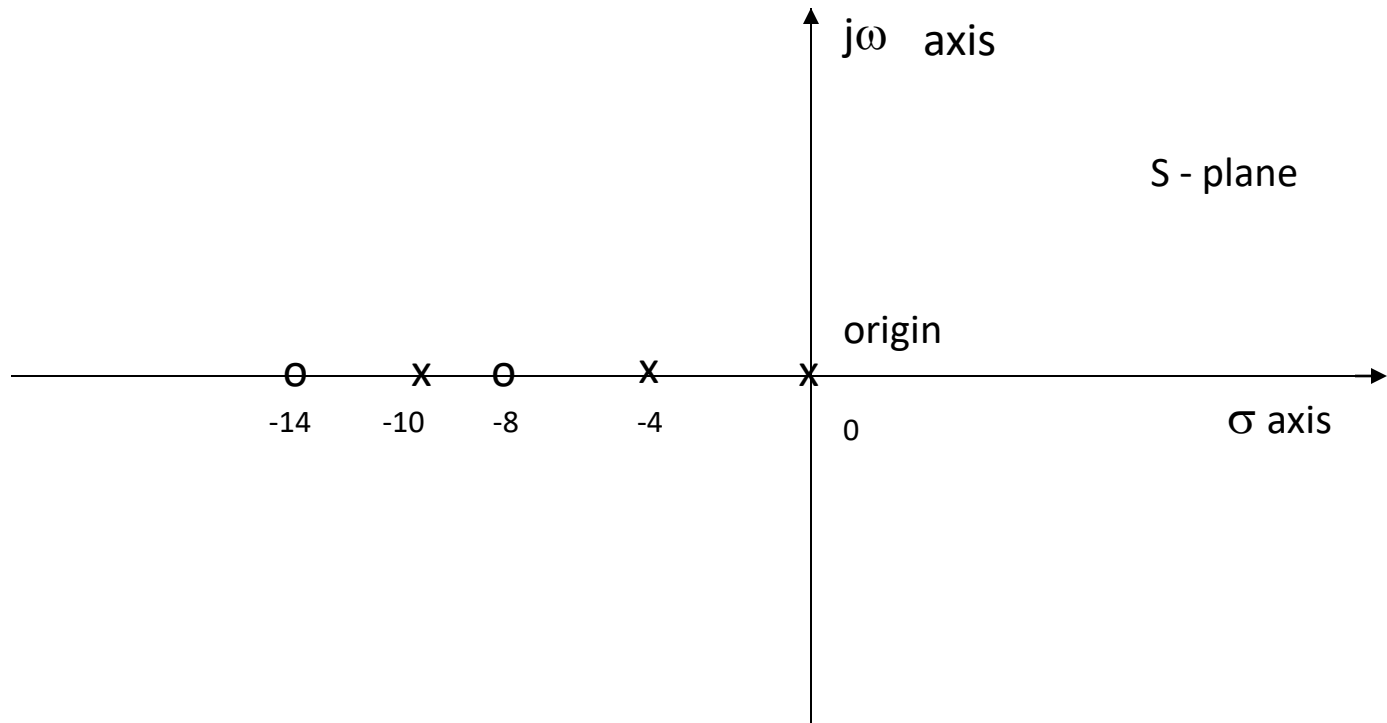

# Poles, Zeros and Bode Plots

## Characterization:

Considering the transfer function of the previous slide. We note that we have 4 different types of terms in the previous general form: These are:

$$K_B, \frac{1}{s}, \frac{1}{(s/p + 1)}, (s/z + 1)$$

## Expressing in dB:

Given the transfer function:

$$G(j\omega) = \frac{K_B(j\omega/z + 1)}{(j\omega)(j\omega/p + 1)}$$

$$20\log |G(j\omega)| = 20\log K_B + 20\log |(j\omega/z + 1)| - 20\log |j\omega| - 20\log |j\omega/p + 1|$$

# Poles, Zeros and Bode Plots

Mechanics: We have 4 distinct terms to consider:

$$20\log K_B$$

$$20\log |(j\omega/z + 1)|$$

$$-20\log |j\omega|$$

$$-20\log |(j\omega/p + 1)|$$

1

1

1

1

1

1

This is a sheet of 5 cycle, semi-log paper.  
This is the type of paper usually used for  
preparing Bode plots.

dB Mag

Phase  
(deg)

$\omega$  (rad/sec)



# Poles, Zeros and Bode Plots

## Mechanics:

The gain term,  $20\log K_B$ , is just so many dB and this is a straight line on Bode paper, independent of  $\omega$  (radian frequency).

The term,  $-20\log |j\omega| = -20\log \omega$ , when plotted on semi-log paper is a straight line sloping at  $-20\text{dB/decade}$ . It has a magnitude of 0 at  $\omega = 1$ .

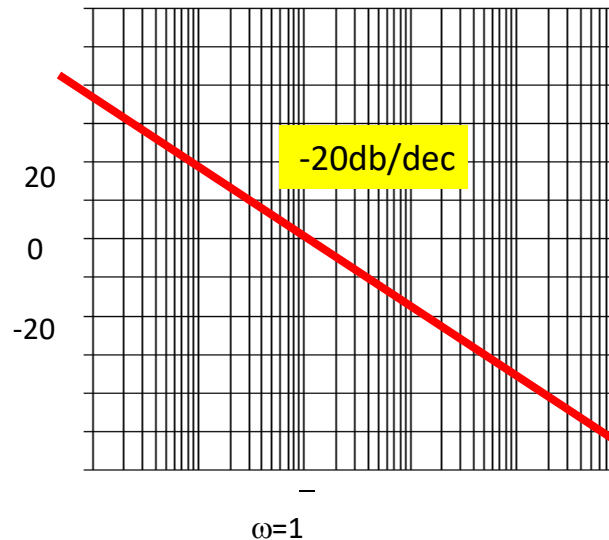

# Poles, Zeros and Bode Plots

## Mechanics:

The term,  $-20\log|(j\omega/p + 1)|$ , is drawn with the following approximation: If  $\omega < p$  we use the approximation that  $-20\log|(j\omega/p + 1)| = 0$  dB, a flat line on the Bode. If  $\omega > p$  we use the approximation of  $-20\log(\omega/p)$ , which slopes at  $-20$ dB/dec starting at  $\omega = p$ . Illustrated below. It is easy to show that the plot has an error of  $-3$ dB at  $\omega = p$  and  $-1$  dB at  $\omega = p/2$  and  $\omega = 2p$ . One can easily make these corrections if it is appropriate.

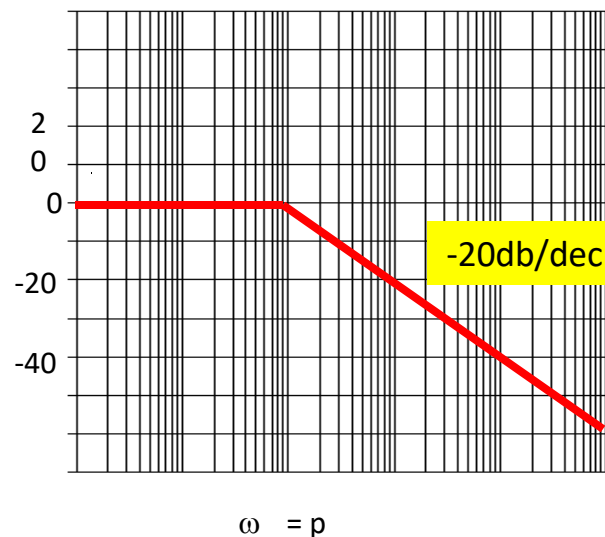

# Poles, Zeros and Bode Plots

## Mechanics:

When we have a term of  $20\log|(j\omega/z + 1)|$  we approximate it be a straight line of slop 0 dB/dec when  $\omega < z$ . We approximate it as  $20\log(\omega/z)$  when  $\omega > z$ , which is a straight line on Bode paper with a slope of + 20dB/dec. Illustrated below.

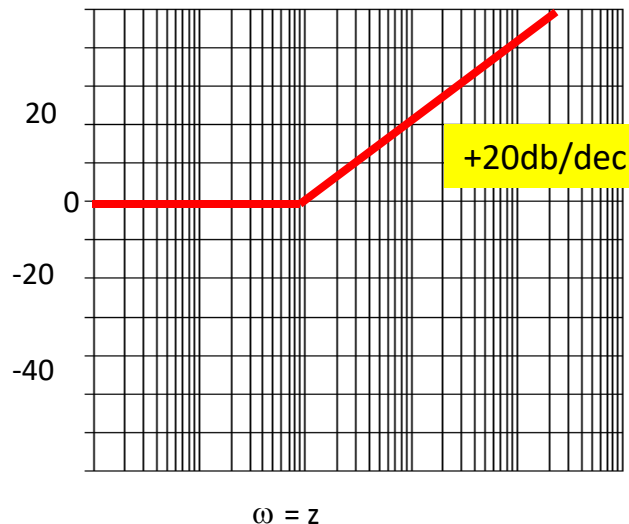

# Example 1:

Given:

$$G(j\omega) = \frac{50,000(j\omega + 10)}{(j\omega + 1)(j\omega + 500)}$$

First: Always, always, always get the poles and zeros in a form such that the constants are associated with the  $j\omega$  terms. In the above example we do this by factoring out the 10 in the numerator and the 500 in the denominator.

$$G(j\omega) = \frac{50,000 \times 10(j\omega / 10 + 1)}{500(j\omega + 1)(j\omega / 500 + 1)} = \frac{100(j\omega / 10 + 1)}{(j\omega + 1)(j\omega / 500 + 1)}$$

Second: When you have neither poles nor zeros at 0, start the Bode at  $20\log_{10}K = 20\log_{10}100 = 40$  dB in this case.

## Example 1: (continued)

Third: Observe the order in which the poles and zeros occur.

This is the secret of being able to quickly sketch the Bode.

In this example we first have a pole occurring at 1 which causes the Bode to break at 1 and slope  $-20$  dB/dec.

Next, we see a zero occurs at 10 and this causes a slope of  $+20$  dB/dec which cancels out the  $-20$  dB/dec, resulting in a flat line ( $0$  dB/dec). Finally, we have a pole that occurs at  $w = 500$  which causes the Bode to slope down at  $-20$  dB/dec.

We are now ready to draw the Bode.

Before we draw the Bode we should observe the range over which the transfer function has active poles and zeros. This determines the scale we pick for the  $w$  (rad/sec) at the bottom of the Bode.

The dB scale depends on the magnitude of the plot and experience is the best teacher here.

# Bode Plot Magnitude for $100(1 + j\omega/10)/(1 + j\omega/1)(1 + j\omega/500)$

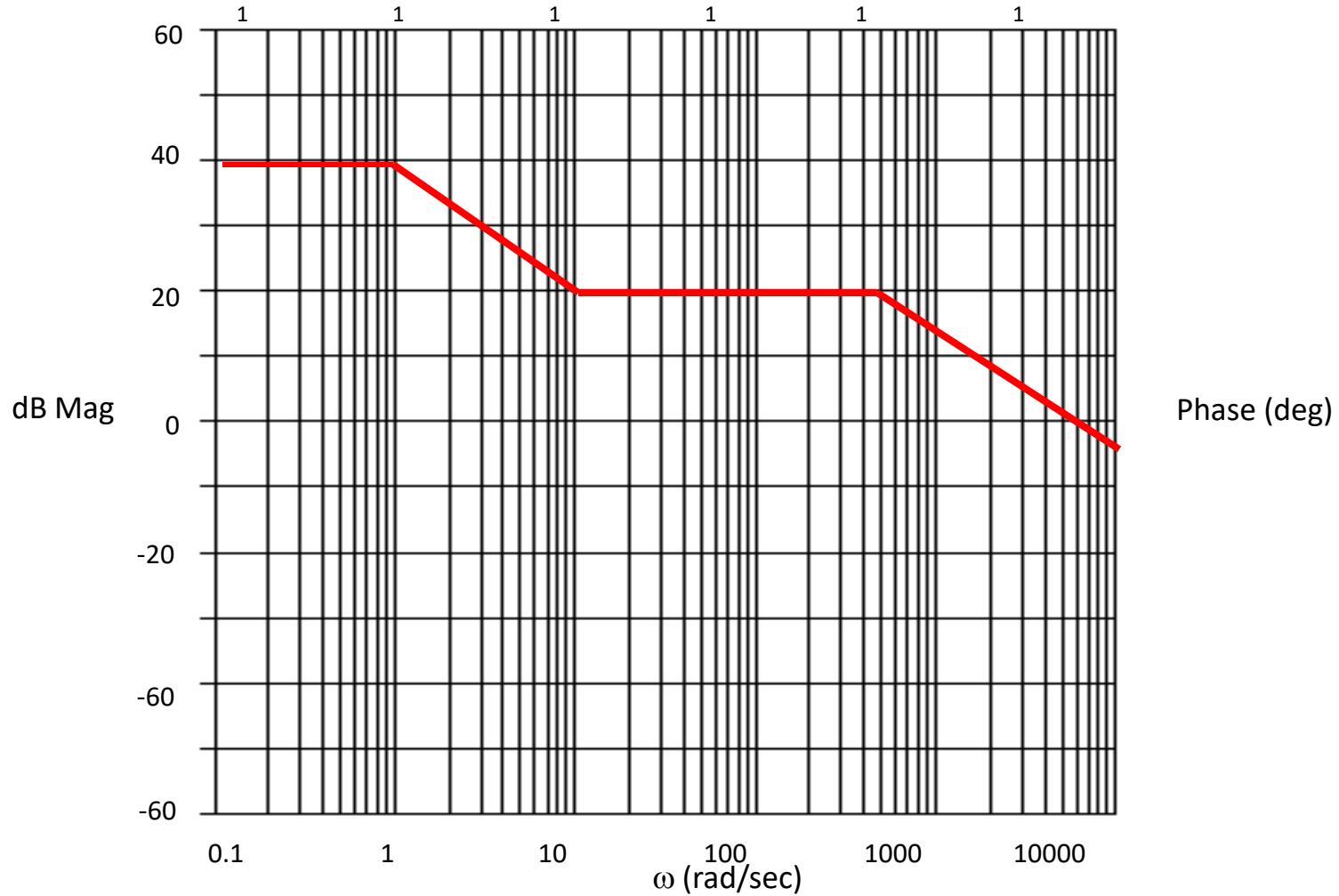

# Using Matlab For Frequency Response

**Instruction:** We can use Matlab to run the frequency response for the previous example. We place the transfer function in the form:

$$\frac{5000(s+10)}{(s+1)(s+500)} = \frac{[5000s+50000]}{[s^2+501s+500]}$$

## **The Matlab Program**

```
num = [5000 50000];  
den = [1 501 500];  
Bode (num,den)
```

In the following slide, the resulting magnitude and phase plots (exact) are shown in light color (blue). The approximate plot for the magnitude (Bode) is shown in heavy lines (red). We see the 3 dB errors at the corner frequencies.

# Bode Diagrams

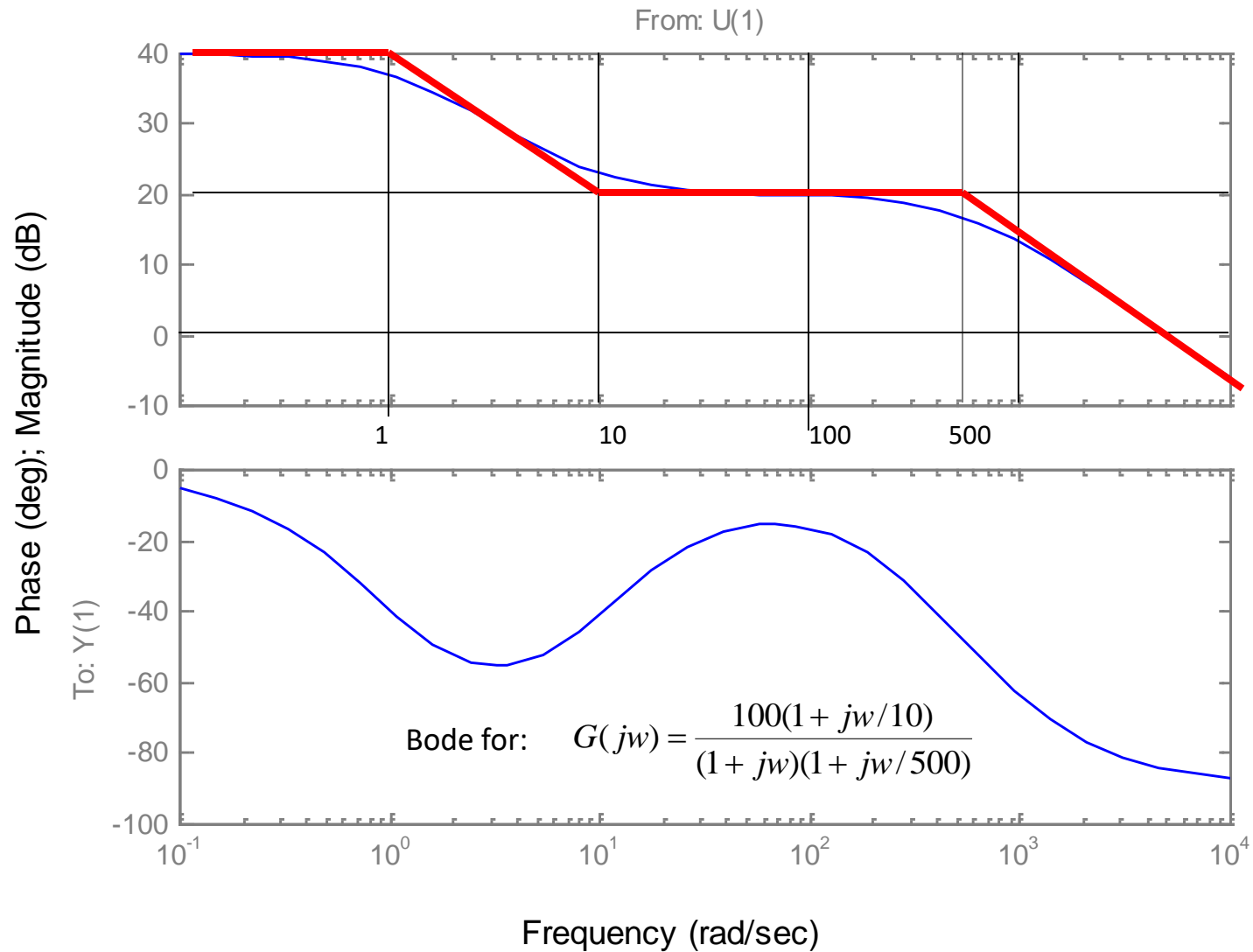



# Phase for Bode Plots

## Comment:

Generally, the phase for a Bode plot is not as easy to draw or approximate as the magnitude. In this course we will use an analytical method for determining the phase if we want to make a sketch of the phase.

## Illustration:

Consider the transfer function of the previous example. We express the angle as follows:

$$\angle G(j\omega) = \tan^{-1}(\omega/10) - \tan^{-1}(\omega/1) - \tan^{-1}(\omega/500)$$

We are essentially taking the angle of each pole and zero. Each of these are expressed as the  $\tan^{-1}(\text{j part}/\text{real part})$

Usually, about 10 to 15 calculations are sufficient to determine a good idea of what is happening to the phase.

# Bode Plots

## Example 2:

Given the transfer function. Plot the Bode magnitude.

$$G(s) = \frac{100(1 + s/10)}{s(1 + s/100)^2}$$

Consider first only the two terms of

$$\frac{100}{j\omega}$$

Which, when expressed in dB, are;  $20\log 100 - 20 \log \omega$ .  
This is plotted below.

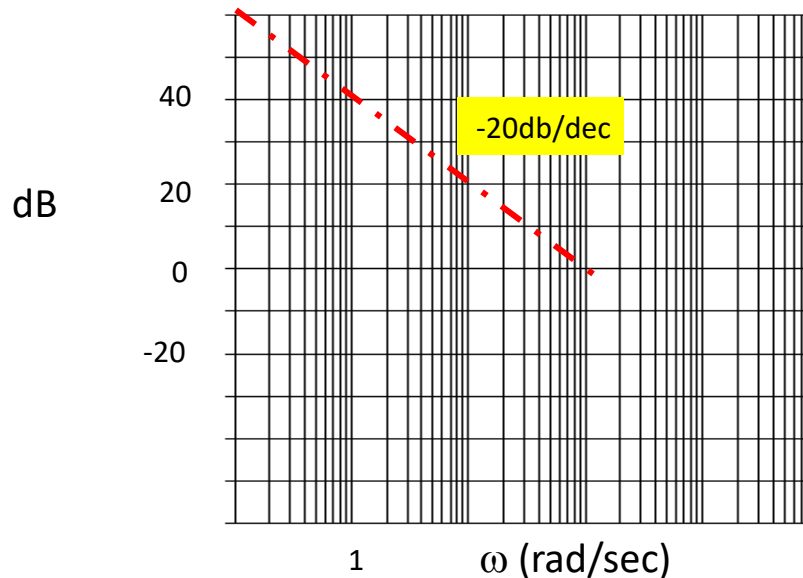

The ..... is a tentative line we use until we encounter the first pole(s) or zero(s) not at the origin.

# Bode Plots

Example 2: (continued) The completed plot is shown below.

$$G(s) = \frac{100(1 + s/10)}{s(1 + s/100)^2}$$

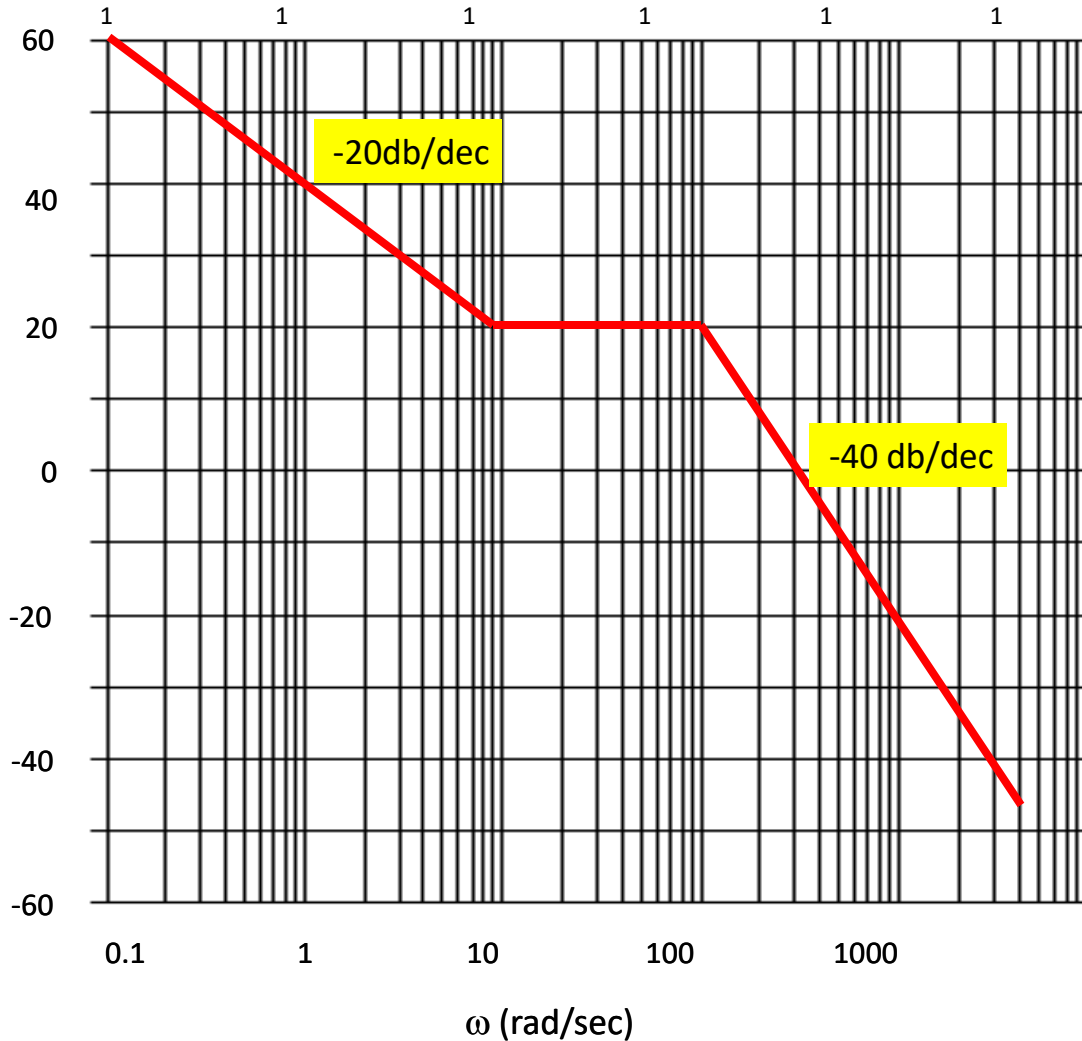

Phase (deg)

$$G(s) = \frac{100(1 + s/10)}{s(1 + s/100)^2}$$

# Bode Plots

## Example 3:

Given:

$$G(s) = \frac{80(1 + j\omega)^3}{(j\omega)^3 (1 + j\omega/20)^2}$$

$$20\log 80 = 38 \text{ dB}$$

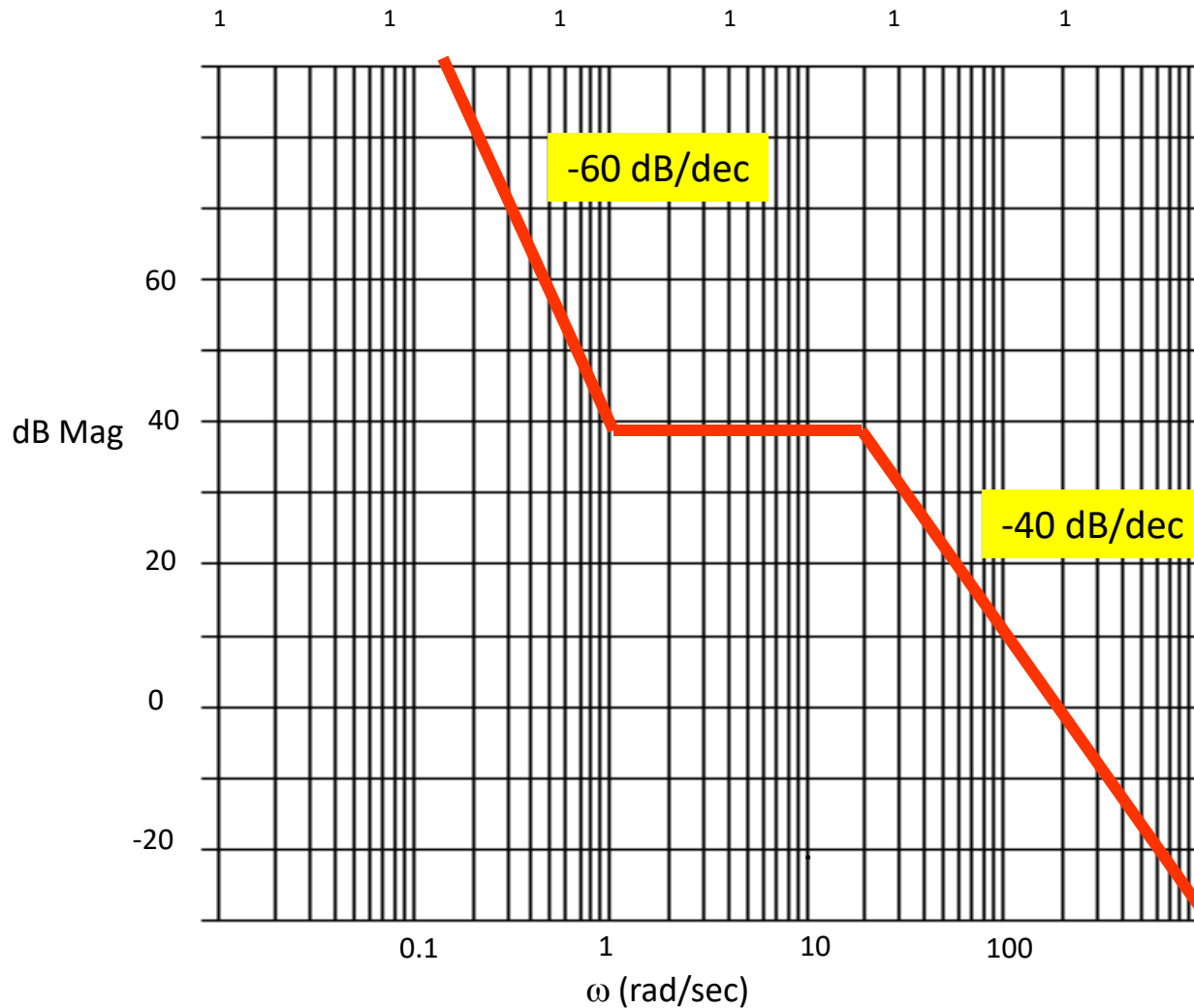

# Bode Plots

Example 4:

Given:

$$G(j\omega) = \frac{10(1 - j\omega/2)}{(1 + j0.025\omega)(1 + j\omega/500)^2}$$

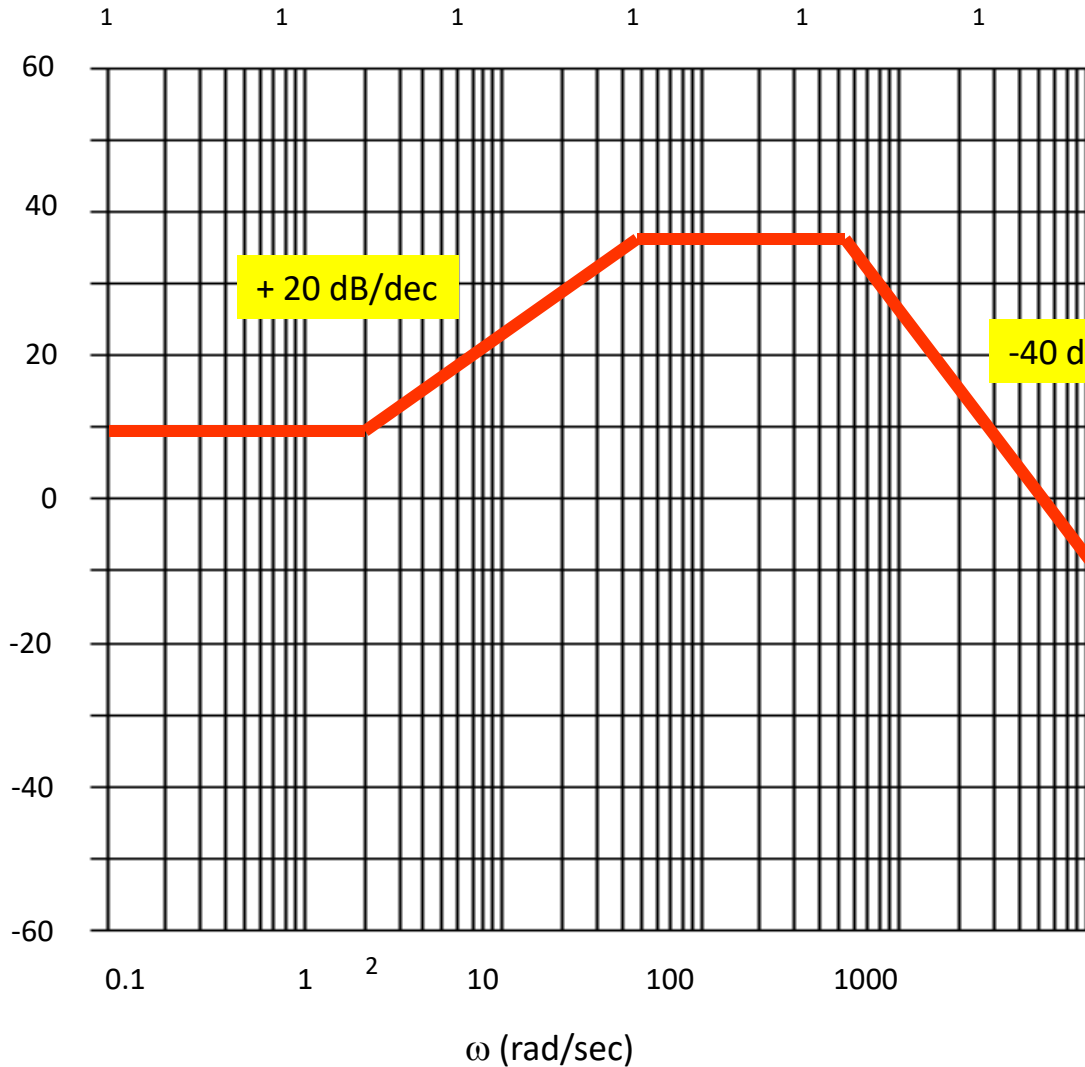

# Bode Plots

Given:

$$G(j\omega) = \frac{(1 + j\omega/30)^2 (1 + j\omega/100)^2}{(1 + j\omega/2)^2 (1 + j\omega/1700)^2}$$

Example 5

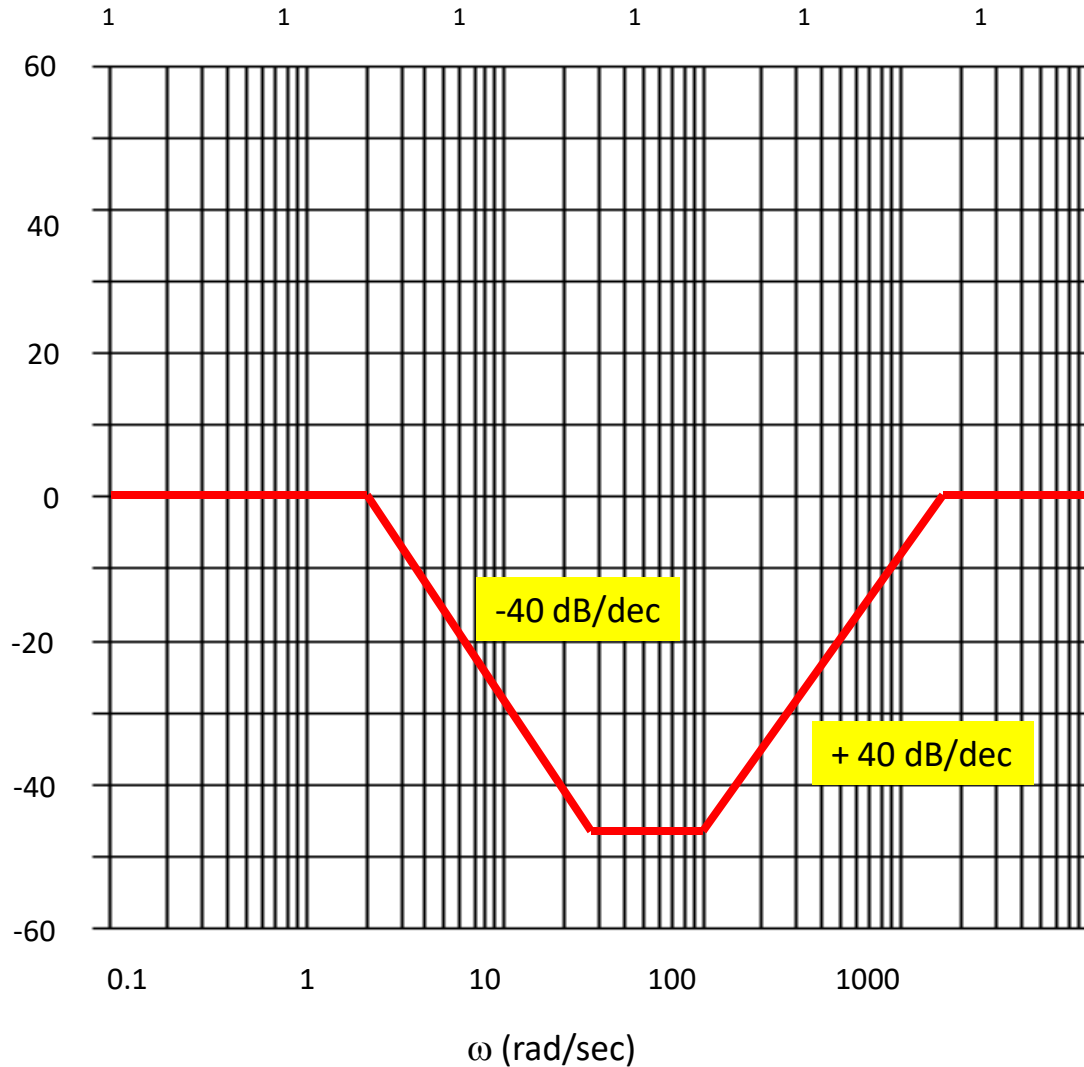

Phase (deg)

Sort of a low pass filter

# Bode Plots

**Given:** problem 11.15 text

**Example 6**

$$H(j\omega) = \frac{640(j\omega + 1)(0.01j\omega + 1)}{(j\omega)^2(j\omega + 10)} = \frac{64(j\omega + 1)(0.01j\omega + 1)}{(j\omega)^2(0.1j\omega + 1)}$$

dB mag

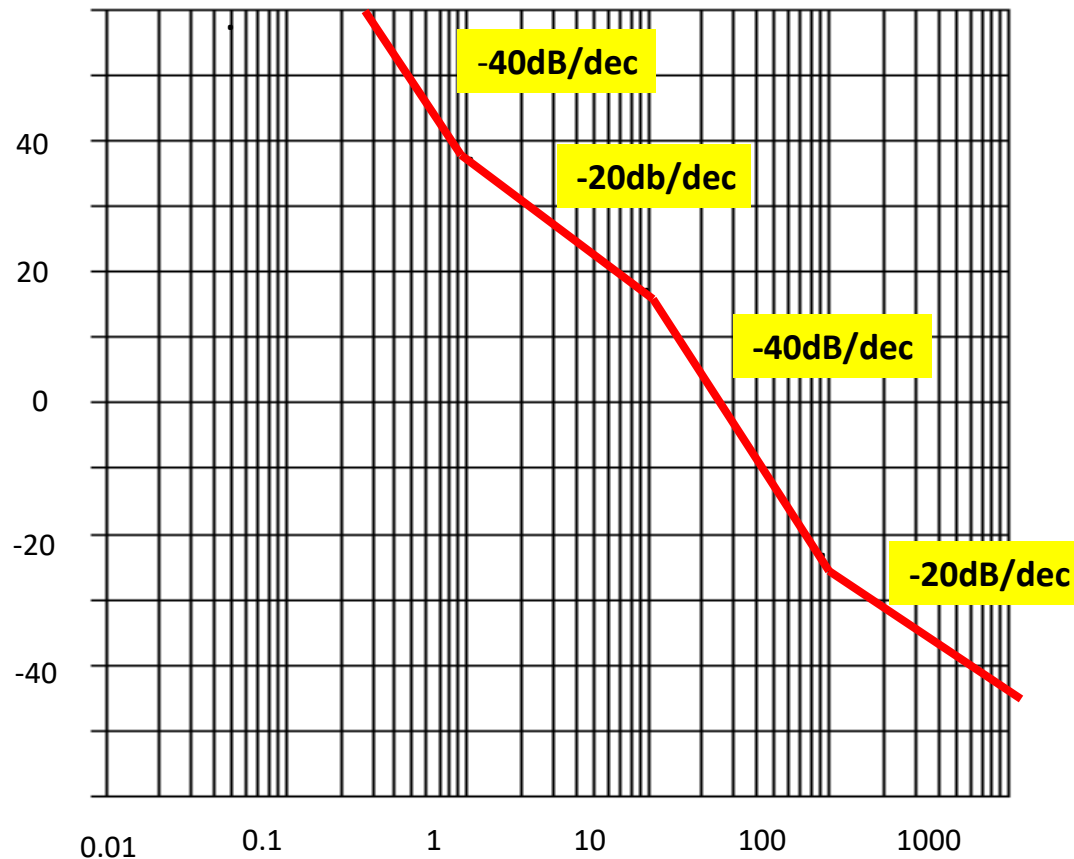

# Bode Plots

Design Problem:

Design a  $G(s)$  that has the following Bode plot.

Example 7

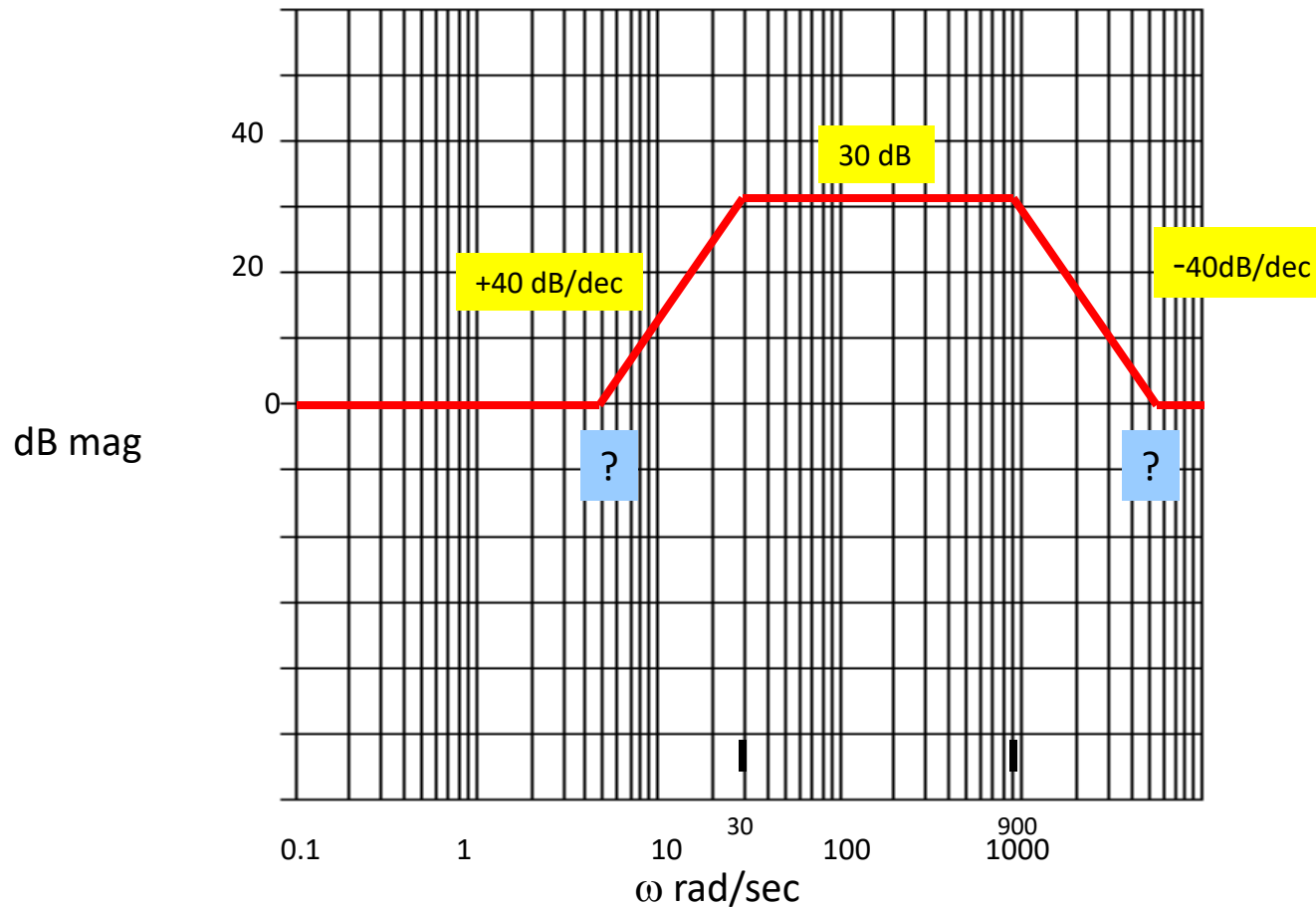



# Bode Plots

**Procedure:** The two break frequencies need to be found.  
Recall:

$$\#dec = \log_{10}[w_2/w_1]$$

Then we have:

$$(\#dec)(40\text{dB/dec}) = 30 \text{ dB}$$

$$\log_{10}[w_1/30] = 0.75 \longrightarrow \underline{w_1 = 5.33 \text{ rad/sec}}$$

**Also:**

$$\log_{10}[w_2/900] (-40\text{dB/dec}) = -30\text{dB}$$

$$\text{This gives } \underline{w_2 = 5060 \text{ rad/sec}}$$

# Bode Plots

Procedure:

$$G(s) = \frac{(1 + s/5.3)^2 (1 + s/5060)^2}{(1 + s/30)^2 (1 + s/900)^2}$$

Clearing:

$$G(s) = \frac{(s + 5.3)^2 (s + 5060)^2}{(s + 30)^2 (s + 900)^2}$$

Use Matlab and conv:

$$N1 = (s^2 + 10.6s + 28.1) \quad N2 = (s^2 + 10120s + 2.56 \times 10^7)$$

$$N1 = [1 \ 10.6 \ 28.1]$$

$$N2 = [1 \ 10120 \ 2.56 \times 10^7]$$

$$N = \text{conv}(N1, N2)$$

$$1 \quad 1.86 \times 10^3 \quad 2.58 \times 10^7 \quad 2.73 \times 10^8 \quad 7.222 \times 10^8$$

$$s^4 \quad s^3 \quad s^2 \quad s^1 \quad s^0$$

# Bode Plots

## Procedure:

The final  $G(s)$  is given by;

$$G(s) = \frac{(s^4 + 10130.6s^3 + 2.571e^8s^2 + 2.716e^8s + 7.194e^8)}{(s^4 + 1860s^3 + 9.189e^2s^2 + 5.022e^7s + 7.29e^8)}$$

## Testing:

We now want to test the filter. We will check it at  $\omega = 5.3$  rad/sec  
And  $\omega = 164$ . At  $\omega = 5.3$  the filter has a gain of 6 dB or about 2.  
At  $\omega = 164$  the filter has a gain of 30 dB or about 31.6.

We will check this out using MATLAB and particularly, Simulink.

# Matlab (Simulink) Model:

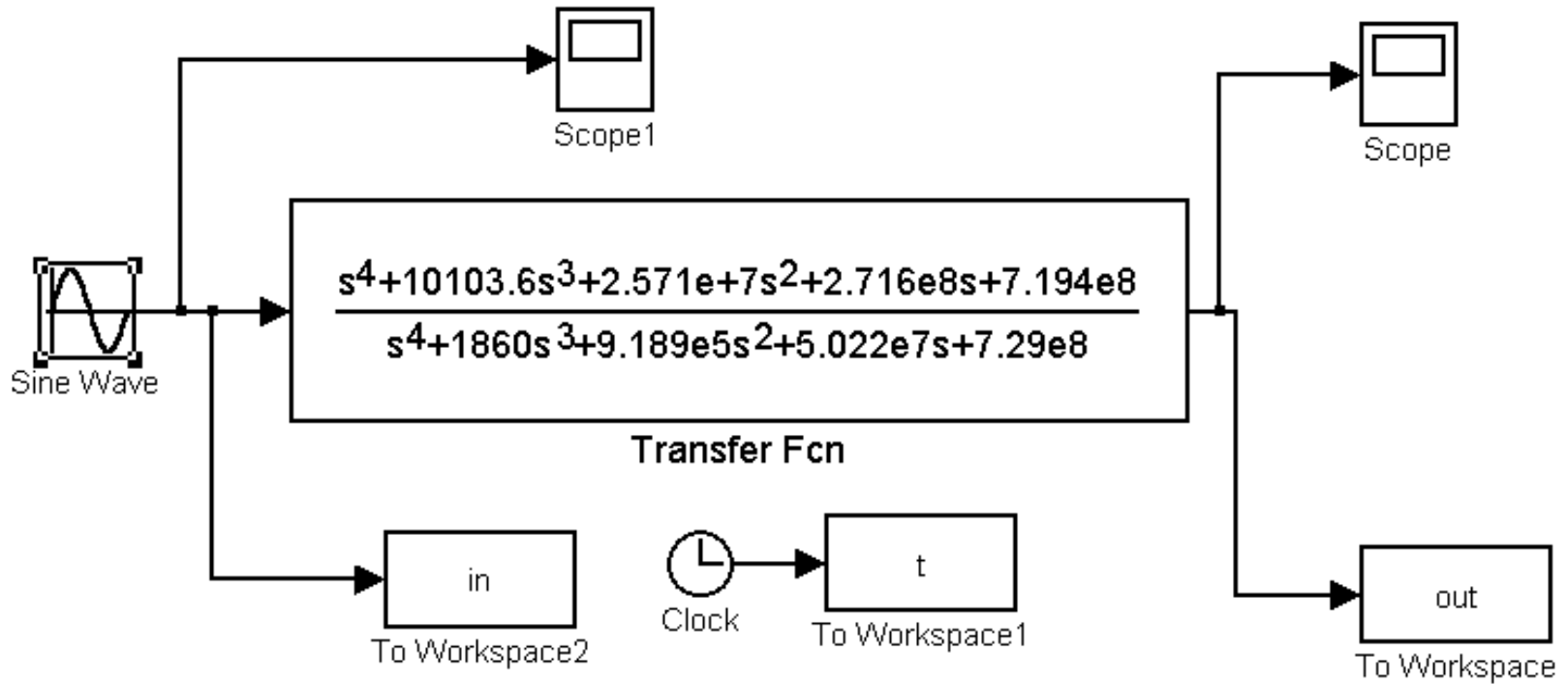

wlg

## Filter Output at $\omega = 5.3$ rad/sec

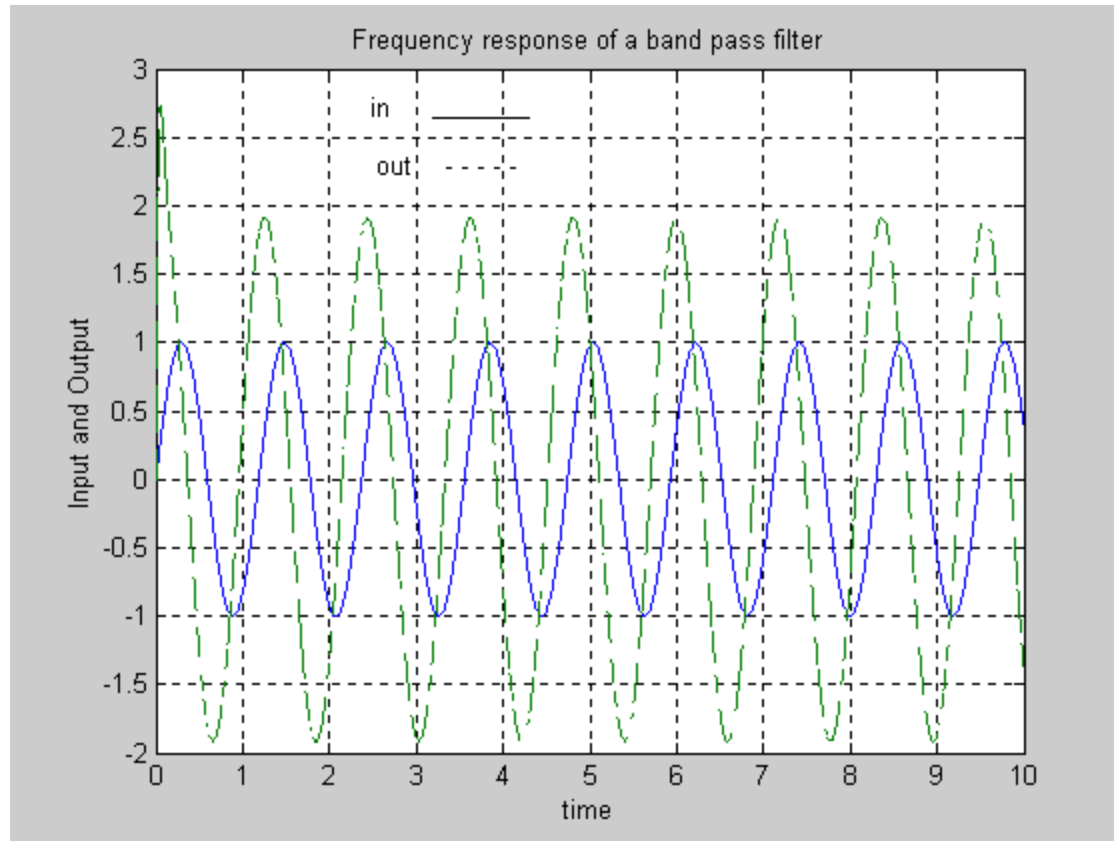

Produced from Matlab Simulink

## Filter Output at $\omega = 70$ rad/sec

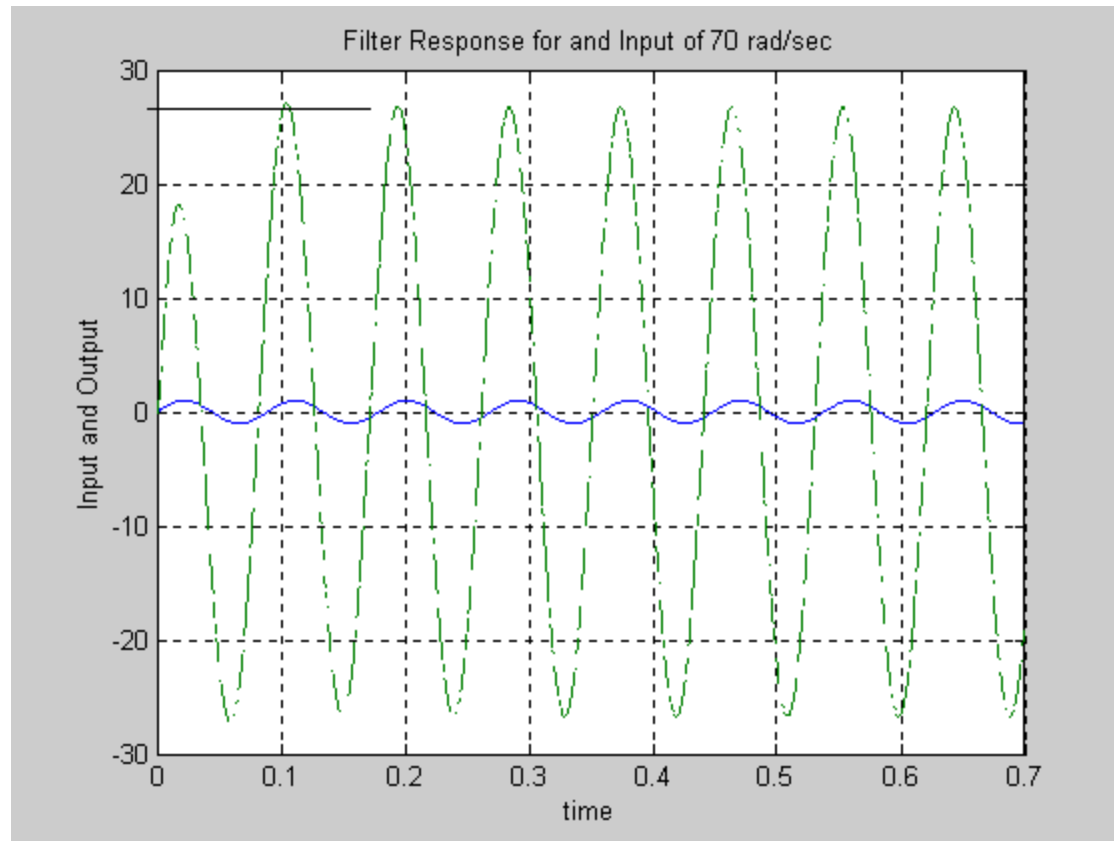

Produced from Matlab Simulink

# Reverse Bode Plot

Required:

Example 8

From the partial Bode diagram, determine the transfer function  
(Assume a minimum phase system)

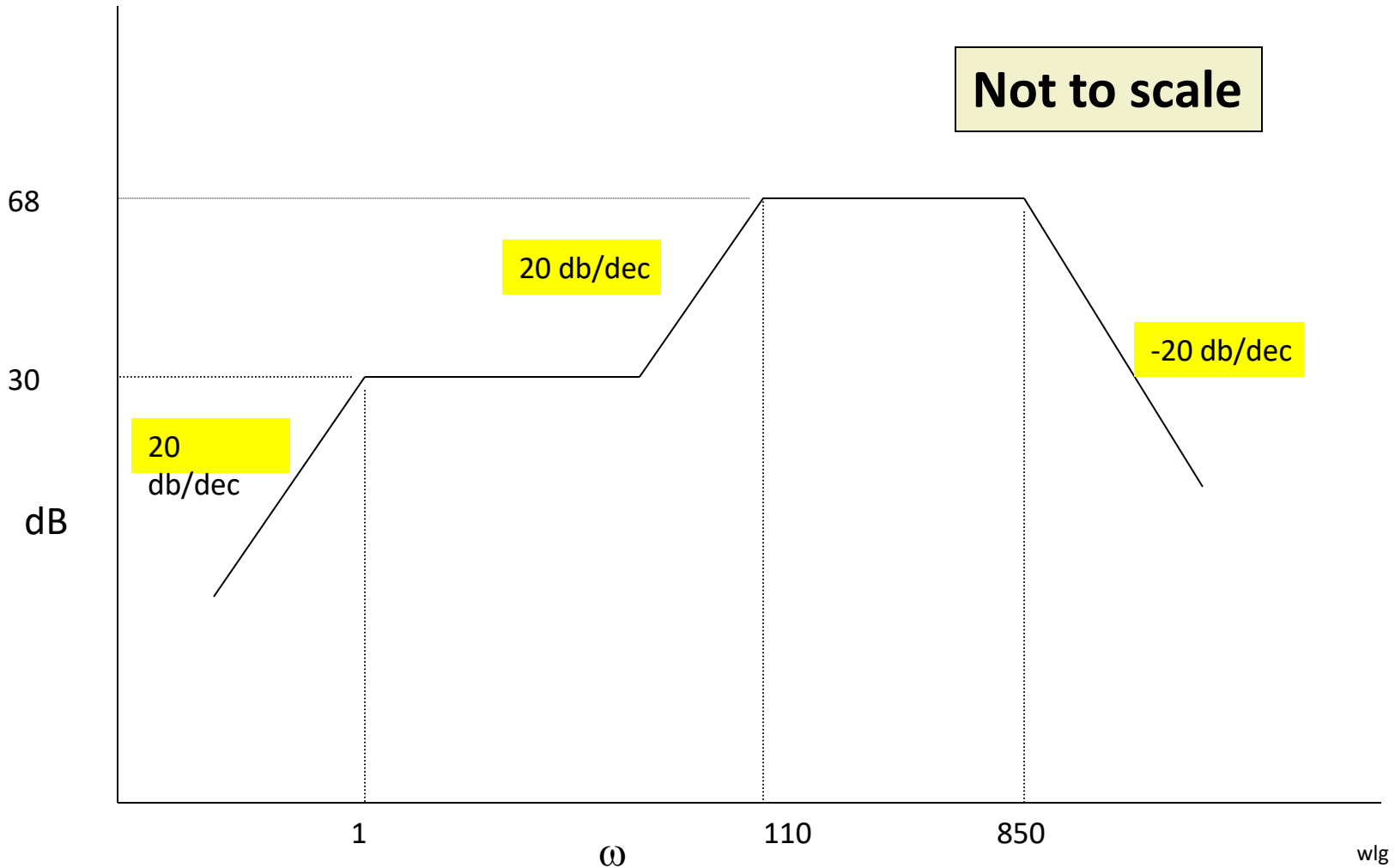

# Reverse Bode Plot

Required:

Example 9

From the partial Bode diagram, determine the transfer function  
(Assume a minimum phase system)

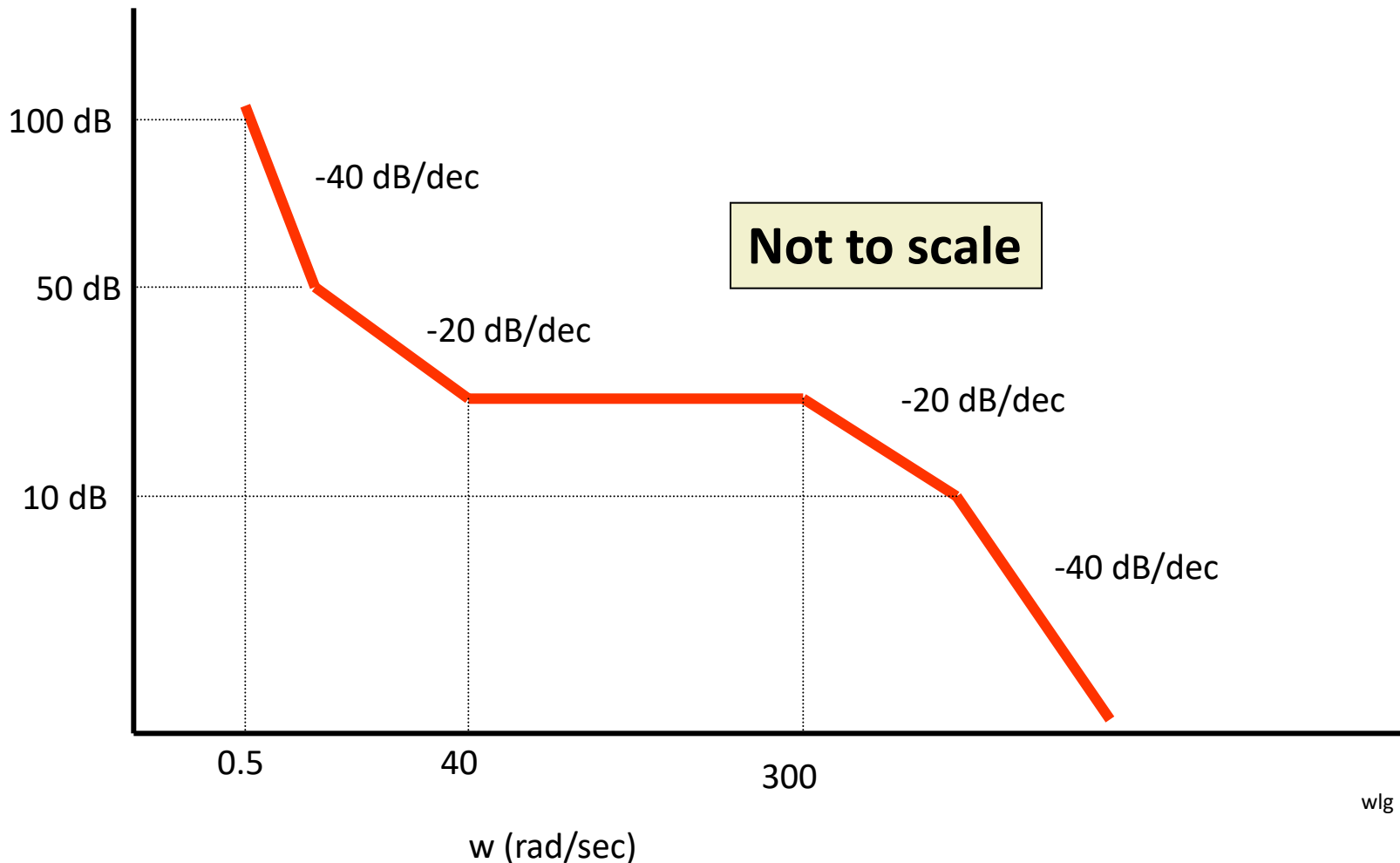



THANK YOU