

POWER POINT PRESENTATION

ON

EHVAC Transmission

2018 - 2019

IV B. Tech II semester (JNTUH-R15)

Mr. B NAVOTHNA, Assistant Professor



ELECTRICAL AND ELECTRONICS ENGINEERING

INSTITUTE OF AERONAUTICAL ENGINEERING

(Autonomous)

DUNDIGAL, HYDERABAD - 500 043

General Overview of HVDC Transmission System



HISTORY

- The first 735 kV system was commissioned in Canada in 1965.
- Since then, voltage levels up to 765 kV have been introduced in Russia with neighboring countries, U.S.A, South Africa, Brazil, Venezuela and South Korea.
- The general trend of 800 kV investments is indicated in the diagram, which shows the total capacity of power transformers and generator step-up transformers for 800 kV delivered by ABB.
- Since the 90's, the investments in 800 kV systems have been much lower compared to the 70's and 80's.
- However, plans are under way for future introduction of 800 kV in India and China.

UNIT-I

INTRODUCTION

WHY EHVAC?

- Reduced line losses
- High transmission efficiency
- Improved voltage regulation
- Flexibility for future system growth
- Increase in transmission capacity of the line

INTRODUCTION

- The increased demand of electricity needs more generation of electrical power.
- As the generation takes place at remote places, an efficient distribution system is necessary.

TYPES OF HVAC TRANSMISSION

HVAC Transmission system can be divided into two parts

(a) Transmission System

(b) Distribution System

Each part is again subdivided into two parts:

1. Primary Transmission

2. Secondary Transmission

HVAC TRANSMISSION SYSTEM

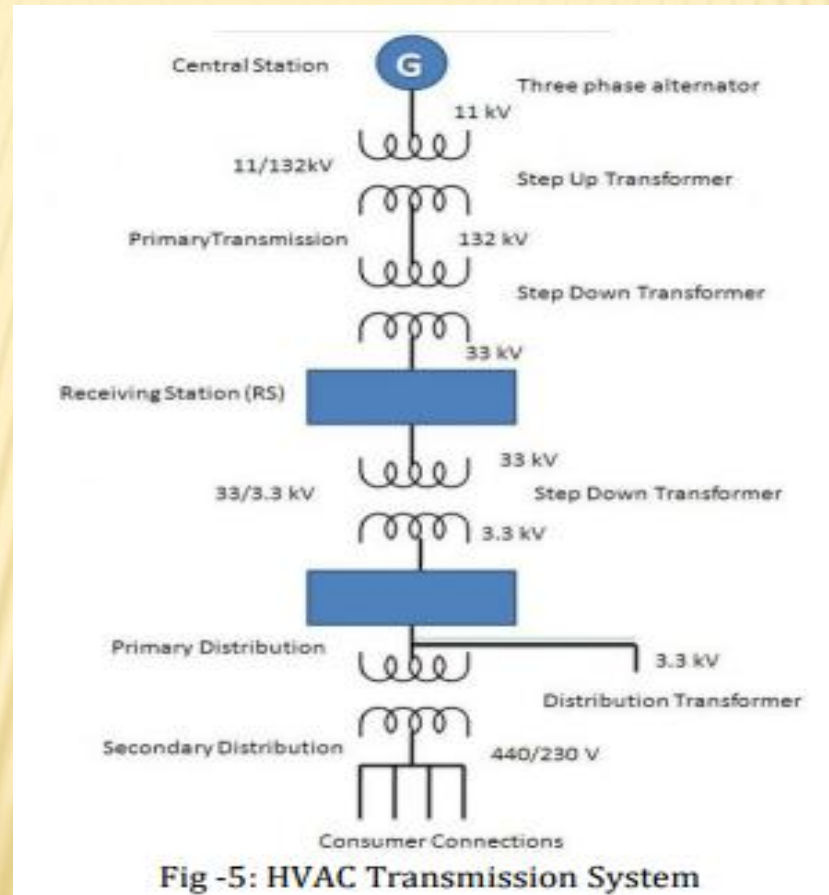

ADVANTAGES

- With increase in the transmission voltage size of the conductors is reduced (Cross section of the conductors reduce as current required to carry reduces).
- As the reduction in current carrying requirement losses reduces results in better efficiency
- Due to low current voltage drop will be less so voltage regulation improves

COMPARISON WITH HVDC

POINTS	EHVAC	HVDC
Voltage levels	220 KV,400 KV,765 KV	± 500
Amount of power delivered	There is limit due to power angle and inductance	No limit
Equivalent essential	Step-up transformer and step-down transformer	Step-up transformer, rectifier and inverter, step-down transformer
Economical viability	EHVAC is economical for bulk power is to be transmitted over a long distance. 500 KM and above	HVDC is economical to transmit bulk amount of power and above. Over a long distance(800 KM and above)

POWER TRANSFER CAPABILITY

V(KV)	220	400	765	1200
P(KW)	193.6	640	2341	5760

- One 765kv transmission line can carry nearly 4 times the power carried by 400kv line.
- One 1200kv transmission line can carry more than twice that of 765kv line.

POWER EQUATION

- ✘ The electric power transmitted by overhead AC system is approximately given by

$$P=V^2/Z$$

Where , V= Operating Voltage

Z= Surge Impedance

- ✘ The power transfer capability increases as it proportional to square of voltage

POWER HANDLING CAPACITY AND LINE LOSS

- ✘ The power handling capacity of a single circuit is

$$P = \frac{E_s E_r \sin \delta}{Lx}$$

where P = power in MW, 3-phase, E_s , E_r = voltages at the sending-end and receiving end, respectively, in kV line-line, δ = phase difference between E_s and E_r , x = positive-sequence reactance per phase, ohm/km, and L = line length, km.

MECHANICAL CONSIDERATIONS IN LINE PERFORMANCE

- Conductor tension,
- Span length,
- Conductor size,
- Type of conductor
- Terrain of line,
- Direction of prevailing winds,
- Type of supporting clamp of conductor-insulator assemblies from the tower,
- Tower type,
- Height of tower,
- Type of spacers and dampers, and
- The vegetation in the vicinity of line.

In general, the most severe vibration conditions are created by winds without turbulences that hills, buildings, and trees help in reducing the severity.

TYPES OF VIBRATION

(1) Aeolian Vibration,

(2) Galloping, and

(3) Wake-Induced
Oscillations.



Fig 1: Stockbridge
Damper

Fig 2: Suspension Clamp

Fig 3: Spacer for two-
conductor bundle

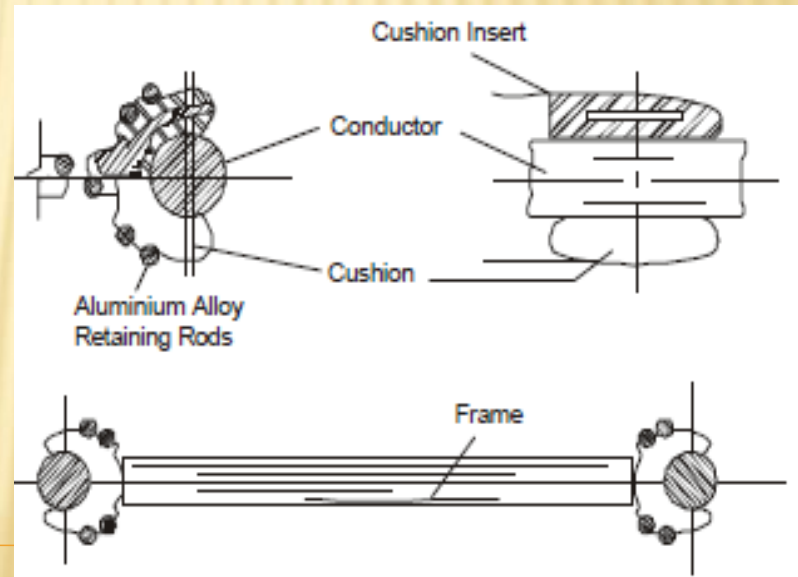
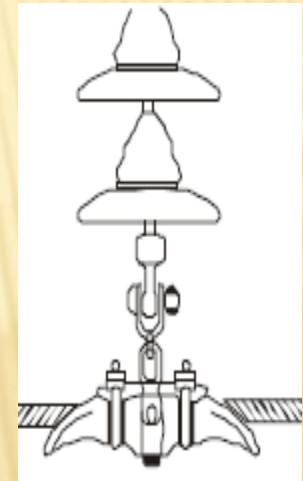
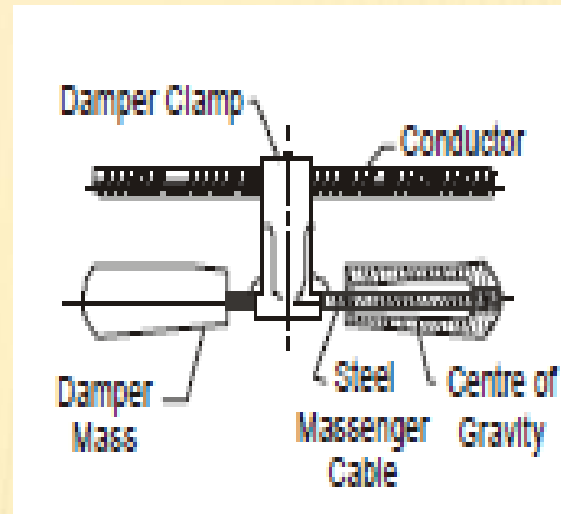

DAMPERS AND SPACERS

COMPARISON OF AC AND DC TRANSMISSION

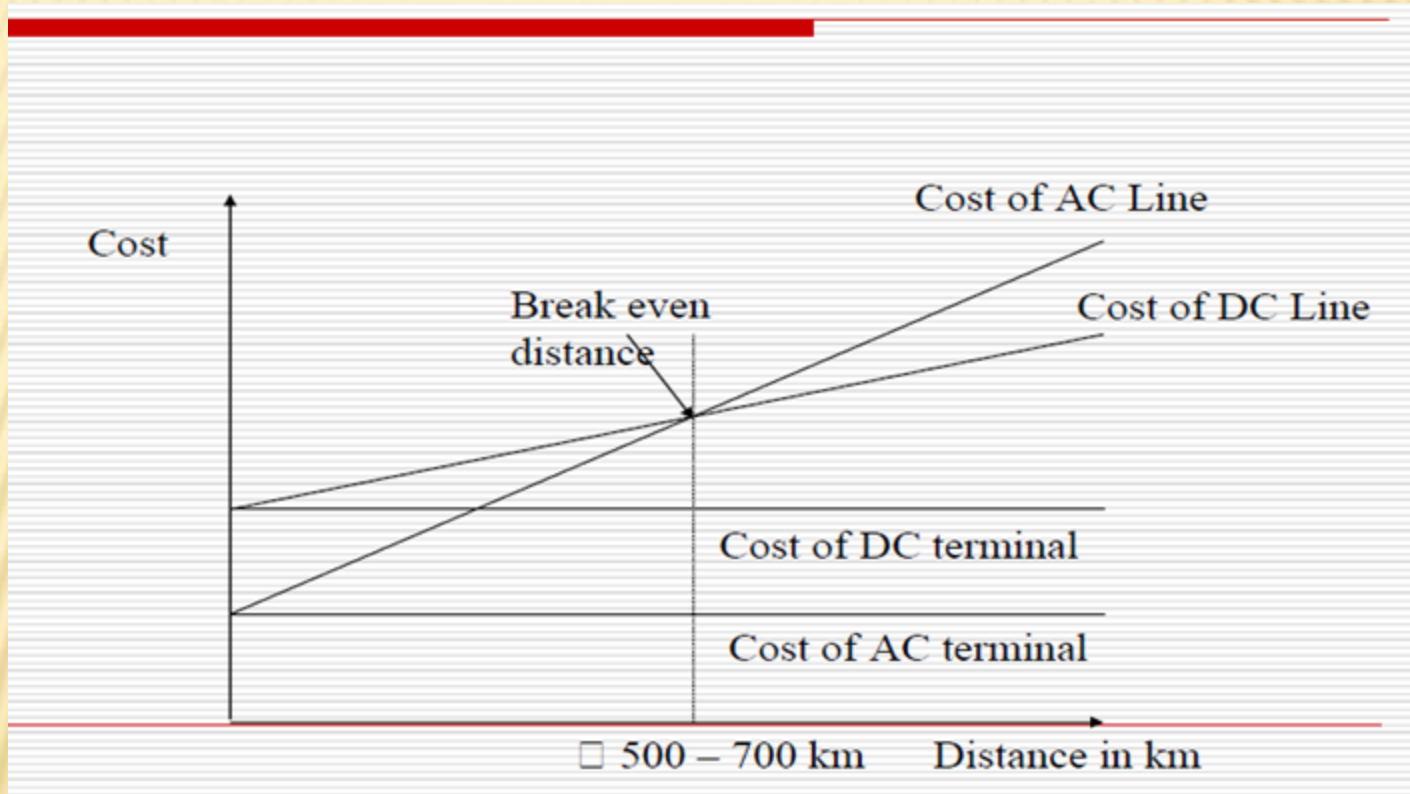

RESISTANCE OF CONDUCTORS

- Conductors used for e.h.v. transmission lines are always stranded. Most common conductors
- Use a steel core for reinforcement of the strength of aluminium, but recently high tensile strength aluminium is being increasingly used, replacing the steel.
- The former is known as ACSR (Aluminium Conductor Steel Reinforced) and the latter ACAR (Aluminium Conductor Alloy Reinforced).

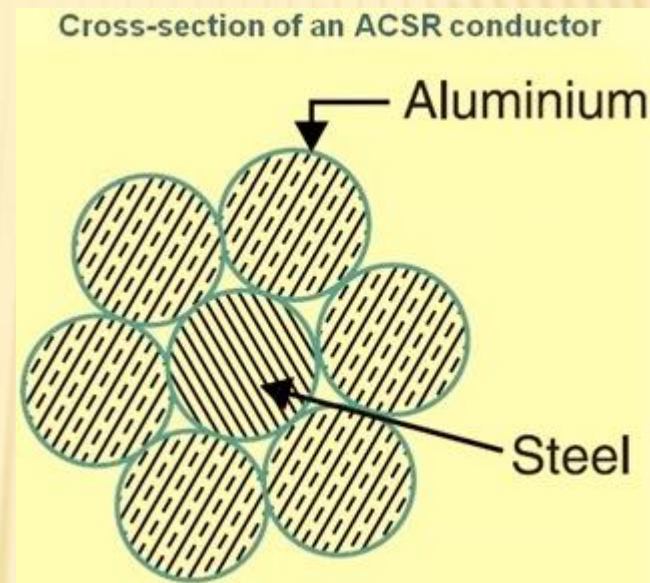

SKIN EFFECT RESISTANCE IN ROUND CONDUCTORS

- The skin effect causes the effective resistance of the conductor to increase at higher frequencies where the skin depth is smaller, thus reducing the effective cross-section of the conductor.
- The skin effect is due to opposing eddy currents induced by the changing magnetic field resulting from the alternating current.

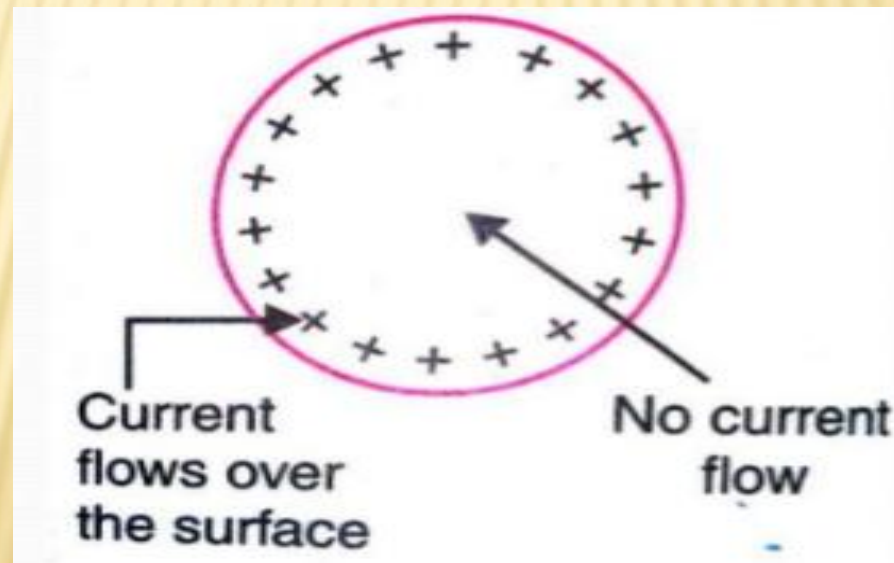

WHAT IS THE NEED OF BUNDLED CONDUCTORS IN EHV TRANSMISSION LINE?

- ✘ Primarily used to reduce the potential gradient on the surface of the conductors so that occurrence of Corona can be reduced.
- ✘ As an advantage we get less Inductance more capacitance less radio interference, reduced value of surge impedance and hence more power carrying capacity of the line.

ADVANTAGES OF BUNDLED CONDUCTORS

- Bundled conductors are primarily employed to reduce the corona loss and radio interference. However they have several advantages:
- ✘ Bundled conductors per phase reduces the voltage gradient in the vicinity of the line. Thus reduces the possibility of the corona discharge. (Corona effect will be observed when the air medium present between the phases charged up and start to ionize and acts as a conducting medium. This is avoided by employing bundled conductors)
- ✘ Improvement in the transmission efficiency as loss due to corona effect is countered.
- ✘ Bundled conductor lines will have higher capacitance to neutral in comparison with single lines.
- ✘ Thus they will have higher charging currents which helps in improving the power factor.

RESISTANCE AND INDUCTANCE OF GROUND RETURN

- ✘ Situations that occur in practice when ground currents have important effect on system performance.

Some of these are:

- Flow of current during short circuits involving ground.
- Switching operations and lightning phenomena.
- Propagation of waves on conductors.
- Radio Noise studies.

UNIT II
VOLTAGE GRADIENTS OF
CONDUCTORS

ELECTROSTATICS

- ✘ Conductors used for e.h.v. transmission lines are thin long cylinders which are known as 'line charges'.
- ✘ Their charge is described in coulombs/unit length which was used for evaluating the capacitance matrix of a multi-conductor line
- ✘ Types of important electrode configurations useful for extra high voltage practice in the field and in laboratories.
- ✘ Examples of this type are sphere-plane gaps, sphere-to-sphere gaps, point-to-plane gaps, rod-to-plane gaps, rod-rod gaps, conductor-to-tower gaps, conductor to-conductor gap above a ground plane, etc.

- This is one of the oldest techniques adopted for the measurement of all the types (dc =, ac ~ and impulse) high voltages of either polarity.
- It remained the most widely used method for decades. The field between two identical spheres is a classical example of "weakly non uniform" field.
- The breakdown characteristic of such a gap is linear for the gap distances not greater than the radius of the spheres.
- Measurement voltage is made as a function of minimum distance at which it can flash over or spark over.



FIELD OF SPHERE GAP

SURFACE VOLTAGE GRADIENT ON CONDUCTORS

- ✘ The surface voltage gradient on conductors in a bundle governs generation of corona on the line which have serious consequences causing audible noise and radio interference.
- ✘ They also affect carrier communication and signaling on the line and cause interference to television reception.
- ✘ Since corona generation depends on the voltage gradient on conductor surfaces, this will be taken up now for e.h.v. conductors with number of sub-conductors in a bundle ranging from 1 to N .
- ✘ The maximum value of N is 8 at present but a general derivation is not difficult.

CALCULATION FOR CONDUCTOR SURFACE GRADIENT

- ✘ The conductor surface gradient is calculated from the following equation:

$$E = (V/\sqrt{3}) * (b / (r * \ln((a/R_e) * 2h / \sqrt{(4h^2 + a^2)})))$$

where E : conductor surface voltage gradient (kV/cm)

V : line voltage (kV)

b : factor for multiple conductors

r : radius of conductor (cm)

R : outside radius of bundle (cm)

R_e : equivalent radius of bundle conductor (cm)

S : distance between component conductor centers (cm)

a : phase spacing (cm)

h : height of conductor above ground (cm)

n : number of component conductors in bundle

WHAT ARE BUNDLED CONDUCTORS?

- ✘ At voltages above 300 kV, *corona* causes a significant power loss and radio interference if a single conductor per phase is used.
- ✘ Instead of using a single conductor, it is preferable to use two or more conductors per phase, in close proximity, which is called **bundled conductors**.
- ✘ Thus, a bundled conductor is a conductor made up of two or more sub-conductors and is used as one phase conductor.
- ✘ The high voltage gradient is reduced considerably by the use of bundled conductors.

NUMBER OF SUB-CONDUCTORS

- The number of sub-conductors used per phase in an Indian transmission system are two (for 400 kV), and four (for 765 kV).
- The bundled conductors for the proposed 1200 kV Ultra High Voltage (UHV) transmission system in India will have 8 sub-conductors.
- Figure 1 shows Bundled conductors with twin, triple and quadruple conductor.
- Figure 2 shows a 765 kV Transmission line in India with quadruplex sub-conductors.

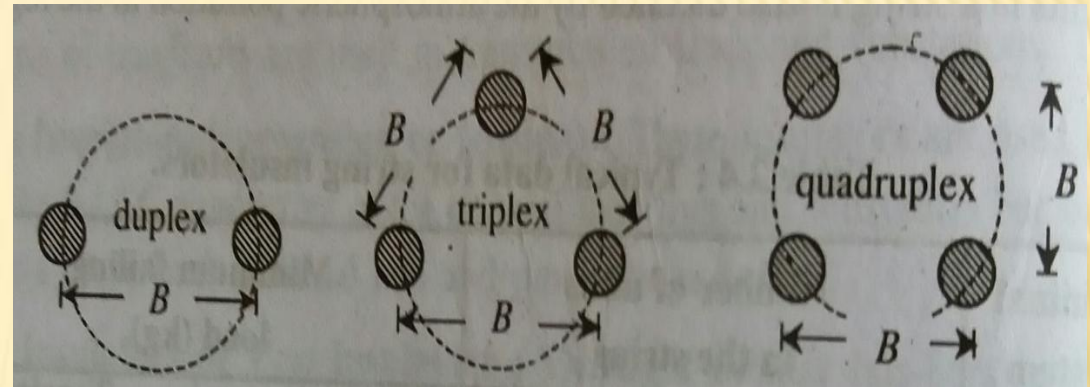

Fig.1: Bundled conductors with twin, triple and quadruple sub-conductors.



Fig.2: 765 kV transmission line in India with 4 sub-conductors per phase (Quadruplex bundle).

BUNDLE SPACING:

- ✘ The spacing between adjacent sub-conductors is called bundle spacing and is almost 30 cm or more. In figure 1, bundle spacing is denoted by 'B'.
- ✘ In almost all cases, the sub-conductors are uniformly distributed on a circle.
- ✘ The radius of the pitch circle on which the sub-conductors are located is called bundled radius.
- ✘ The various advantages of using bundled conductors are reduced reactance, voltage gradient, corona loss, radio interference, and surge impedance.

UNIT III

CORONA EFFECTS

WHAT IS CORONA?

- ✘ Electric transmission lines can generate a small amount of sound energy as a result of corona.
- ✘ Corona is a phenomenon associated with all transmission lines. Under certain conditions, the localized electric field near energized components and conductors can produce a tiny electric discharge or corona that causes the surrounding air molecules to ionize, or undergo a slight localized change of electric charge.
- ✘ Utility companies try to reduce the amount of corona because in addition to the low levels of noise that result, corona is a power loss, and in extreme cases, it can damage system components over time.
- ✘ Corona occurs on all types of transmission lines, but it becomes more noticeable at higher voltages (345 kV and higher). Under fair weather conditions, the audible noise from corona is minor and rarely noticed.
- ✘ During wet and humid conditions, water drops collect on the conductors and increase corona activity. Under these conditions, a crackling or humming sound may be heard in the immediate vicinity of the line.
- ✘ Corona results in a power loss. Power losses like corona result in operating inefficiencies and increase the cost of service for all ratepayers; a major concern in transmission line design is the reduction of losses.

CORONA PHENOMENON AT HIGH VOLTAGE

- ✘ Corona phenomenon is the ionization of air surrounding the power conductors.
- ✘ Free electrons are normally present in the atmosphere.
- ✘ The free electrons will move with certain velocity depending upon the field strength.
- ✘ These electrons on their movement collide with the molecules of air and liberate more electrons.
- ✘ The process of ionization is cumulative and ultimately forms and electron avalanche.

ELECTRICAL BREAKDOWN

- ❖ The electrical breakdown of surrounding air around the conductor is accompanied by-
 - a faint glow around the conductor,
 - a hissing sound,
 - vibration in conductors,
 - formation of ozone and oxides of nitrogen,
 - loss of power, and
 - radio interference.

FACTORS AFFECTING CORONA LOSS IN AN OVERHEAD TRANSMISSION LINE

- ✘ The important factors that affect the corona loss in an overhead transmission line are -
 - ✘ frequency and waveform of supply,
 - ✘ spacing between conductors,
 - ✘ condition of conductor surface,
 - ✘ atmospheric conditions,
 - ✘ conductor diameter and
 - ✘ number of conductors per phase.

CORONA CALCULATIONS

- ✘ The following corona calculations are from Dielectric Phenomena in High Voltage Engineering

1. For Concentric Cylinders in Air:

- ✘ Corona will not form when $RO / RI < 2.718$. (Arcing will occur instead when the voltage is too high.)

2. For Parallel Wires in Air:

- ✘ Corona will not form when $X / r < 5.85$. (Arcing will occur instead when the voltage is too high.)

3. For Equal Spheres in Air:

- ✘ Corona will not form when $X / R < 2.04$. (Arcing will occur instead when the voltage is too high.)
- ✘ Arcing difficult to avoid when $X / R < 8$

EFFECTS OF CORONA

(1) Audible Noise

(2) Radios and Television Interference

(3) Gaseous Effluents

(4) Induced Currents

(5) Fuel Ignition

(6) Cardiac Pacemakers

(7) Computer Interference



AUDIBLE NOISE

- ✘ During corona activity, transmission lines (primarily those rated at 345 kV and above) can generate a small amount of sound energy. This audible noise can increase during foul weather conditions.
- ✘ Water drops may collect on the surface of the conductors and increase corona activity so that a crackling or humming sound may be heard near a transmission line.
- ✘ Transmission line audible noise is measured in decibels using a special weighting scale, the “A” scale that responds to different sound characteristics similar to the response of the human ear.
- ✘ Audible noise levels on typical 230 kV lines are very low and are usually not noticeable.
- ✘ For example, the calculated rainy weather audible noise for a 230 kV transmission line at the right-of-way edge is about 25 dBA, which is less than ambient levels in a library and much less than background noise for wind and rain.

CORONA LOSS

- ✘ When an alternating potential difference is applied across two conductors whose spacing is large in compares ion with their diameter then the atmosphere air surrounding the conductor realize electrostatic stress.
- ✘ At low voltage there is no change in the condition of atmospheric air around the conductors but when the potential difference is gradually increased, a stage arrive when fan is luminous glow of violet color appears with the hissing sound .
- ✘ This phenomenon is known as visual corona. If the potential difference raised still further, the glow and the noise will increase eventually a spark over of air insulation will take place.
- ✘ This phenomenon is lies in transmission line of 100KV and above.

REDUCING POWER LOSS DUE TO CORONA

- ✘ The use of bundle conductors reduce corona loss
- ✘ Spacing between conductors is selected so that corona is tolerable
- ✘ Since the shape of conductors affect corona loss, cylindrical shape conductors have uniform field that reduces corona loss than any other shape
- ✘ The voltage stress and electric field gradient should be minimized which can be accomplished by using good high voltage design practices. Using conductors with large radii reduce corona loss
- ✘ Void free solid conductors and insulators should be used
- ✘ Corona formation can be suppressed, if the terminals on high voltage equipment are designed with smooth round diameter rounded shapes like balls and the addition of corona rings to insulators of high voltage transmission lines

RADIO INTERFERENCE

- ✘ Pulse type of corona gives interference to radio broadcast in the range of 0.5 MHz to 1.6 MHz.
- ✘ In addition to corona generated on line conductors, there are spark discharges from broken insulators and loose wires which interfere with TV reception in the 80 – 20 MHz range.
- ✘ Corona on conductors also causes interference to Carrier Communication and Signaling in the frequency range 30-500 KHz. As in most gas discharge phenomenon under high impressed electric fields, free electrons and ions are created in space which contain very few initial electrons.
- ✘ We can therefore expect a buildup of resulting current in the conductor from a zero value to maximum or peak caused by the avalanche mechanism and their motion towards the proper electrode. Once the peak value is reached there is fall in current because of lowering of electric field due to relatively heavy immobile space charge cloud which lowers the velocity of ions.
- ✘ We can therefore expect pulses to be generated with short crest times and relatively longer fall times.

UNIT IV
ELECTRO STATIC FIELD

ELECTROSTATIC EFFECT ON ELECTRIC-FIELD OF EHV LINE

- ✘ **Electric fields** are due to voltage so they are present in electrical appliances and cords whenever the electric cord to an appliance is plugged into an outlet (even if the appliance is turned off).
- ✘ Electric fields (E) exist whenever a (+) or (-) electrical charge is present. They exert forces on other charges within the field.
- ✘ Any electrical wire that is charged will produce an electric field (i.e. Electric field produces charging of bodies, discharge currents, biological effects and sparks). This field exists even when there is no current flowing.
- ✘ The higher the voltage, the stronger is electric field at any given distance from the wire.
- ✘ The strength of the electric field is typically measured in volts per meter (V/m) or in kilovolts per meter (kV/m). Electric fields are weakened by objects like trees, buildings, and vehicles. Burying power lines can eliminate human exposure to electric fields from this source.

ELECTROSTATIC EFFECT ON HUMAN BEINGS

- ✘ The human body is composed of some biological materials like blood, bone, brain, lungs, muscle, skin etc. The permeability of human body is equal to permeability of air but within a human body has different electromagnetic values at a certain frequency for different material.
- ✘ The human body contains free electric charges (largely in ion-rich fluids such as blood and lymph) that move in response to forces exerted by charges on and currents flowing in nearby power lines. The processes that produce these body currents are called **electric and magnetic induction**.
- ✘ In electric induction, charges on a power line attract or repel free charges within the body. Since body fluids are good conductors of electricity, charges in the body move to its surface under the influence of this electric force.
- ✘ For example, a positively charged overhead transmission line induces negative charges to flow to the surfaces on the upper part of the body. Since the charge on power lines alternates from positive to negative many times each second, the charges induced on the body surface alternate also.

ELECTROSTATIC EFFECT ON HUMAN BEINGS-1

- ✘ Negative charges induced on the upper part of the body one instant flow into the lower part of the body the next instant. Thus, **power-frequency electric fields induce currents in the body (Eddy Current) as well as charges on its surface.**
- ✘ The currents induced in the body by magnetic fields are greatest near the periphery of the body and smallest at the center of the body.
- ✘ It is believed that, the magnetic field might induce a voltage in the tissue of human body which causes a current to flow through it due to its conductivity of around them.
- ✘ The magnetic field has influence on tissues in the human body. These influences may be beneficial or harmful depending upon its nature.
- ✘ The magnitude of surface charge and internal body currents that are induced by any given source of power-frequency fields depends on many factors.

ELECTROSTATIC EFFECT ON HUMAN BEINGS-2

- ✘ These include the magnitude of the charges and currents in the source, the distance of the body from the source, the presence of other objects that might shield or concentrate the field, and body posture, shape, and orientation.
- ✘ **For this reason the surface charges and currents which a given field induces are very different for different Human and animals.**
- ✘ When a person who is isolated from ground by some insulating material comes in close proximity to an overhead transmission line, an electrostatic field is set in the body of human being, having a resistance of about 2000 ohms.
- ✘ When the same person touches a grounded object, it will discharge through his body causing a large amount of discharge current to flow through the body. Discharge currents from 50-60 Hz electromagnetic fields are weaker than natural currents in the body, such as those from the electrical activity of the brain and heart.

ELECTROSTATIC EFFECT ON HUMAN BEINGS-3

➤ **Short term Health Problem**

- ✘ Headaches.
- ✘ Fatigue
- ✘ Anxiety
- ✘ Insomnia
- ✘ Prickling and/or burning skin
- ✘ Rashes
- ✘ Muscle pain

➤ **Long term Health Problem**

- ✘ Risk of damaging DNA.
- ✘ Risk of Cancer
- ✘ Risk of Leukemia
- ✘ Risk of Neurodegenerative disease:
- ✘ Risk of Miscarriage

ELECTROSTATIC EFFECT ON ANIMALS

- ✘ Many researchers are studying the effect of Electrostatic field on animals. In order to do so they keep the cages of animals under high Electrostatic field of about 30 kV/m.
- ✘ The results of these Experiments are shocking as animals (are kept below high Electrostatic field their body acquires a charge & when they try to drink water, a spark usually jumps from their nose to the grounded Pipe) like hens are unable to pick up grain because of chattering of their beaks which also affects their growth.

ELECTROSTATIC EFFECT ON PLANT LIFE

- ✘ Most of the areas in agricultural and forest lands where high power transmission lines pass. The voltage level of high power transmission Lines are 400KV, 230KV, 110KV, 66KV etc. The electromagnetic field from high power transmission lines affects the growth of plants.
- ✘ Gradually increases or decreases and reaches to maximum current or minimum current and thereafter it starts to fall down to lowest current or raises to maximum current or a constant current. Again the current, it evinces with little fluctuations till the next day morning.
- ✘ Current in Power transmission lines varies according to Load (it depending upon the amount of electricity consumed by the consumers). Hence the effect of EMF (due to current flowing in the power lines) upon the growth of plants under the high power transmission lines remains unaltered throughout the year.
- ✘ From various practically study it was found that the response of the crop to EMF from 110 KV and 230 KV Power lines showed variations among themselves. Based on the results the growth characteristics like shoot length, root length, leaf area, leaf fresh weight, specific leaf weight, shoot/root ratio, total biomass content and total water content of the four crop plants were reduced significantly over the control plants.

ELECTROSTATIC EFFECT ON PIPE LINE/FENCE/CABLES

- ✘ A fence, irrigation pipe, pipeline, electrical distribution line forms a conducting loops when it is grounded at both ends. The earth forms the other portion of the loop. The magnetic field from a transmission line can induce a current to flow in such a loop if it is oriented parallel to the line.
- ✘ If only one end of the fence is grounded, then an induced voltage appears across the open end of the loop. The possibility for a shock exists if a person closes the loop at the open end by contacting both the ground and the conductor.
- ✘ For fences, buried cables, and pipe lines proper care has been taken to prevent them from charging due to Electrostatic field.
- ✘ When using pipelines which are more than 3 km in length & 15 cm in Diameter they must be buried at least 30 laterally from the line center.

UNIT V

VOLTAGE CONTROL

SYNCHRONOUS CONDENSER

- ✘ Synchronous Condenser is also known as Synchronous Compensator or Synchronous Phase Modifier.
- ✘ A synchronous condenser or a synchronous compensator is a synchronous motor running without a mechanical load.
- ✘ It can generate or absorb reactive volt-ampere (VAr) by varying the excitation of its field winding.
- ✘ It can be made to take a leading current with over-excitation of its field winding.
- ✘ When the motor power factor is unity, the DC excitation is said to be normal. Over-excitation causes the motor to operate at a leading power factor. Under excitation causes it to operate at a lagging power factor. When the motor is operated at no load with over-excitation, it takes a current that leads the voltage by nearly 90 degrees.
- ✘ Thus, it behaves like a capacitor and under such operating conditions, the synchronous motor is called a synchronous capacitor.
- ✘ Since a synchronous condenser behaves like a variable inductor or a variable capacitor, it is used in power transmission systems to regulate line voltage.

VOLTAGE CONTROL BY SYNCHRONOUS CONDENSERS:

- ✘ Synchronous condensers are over excited synchronous motors installed in the power system to deliver the reactive power.
- ✘ These synchronous phase modifiers are located near the load improves the voltage profile of the power system.
- ✘ The main advantage of synchronous phase modifiers are the ability to deliver the reactive power can be adjusted unlike static shunt capacitors.

SERIES COMPENSATION

- **Voltage Control by Series Capacitors**
- ✘ In Extra High Voltage (EHV) or Ultra High Voltage System (UHV) systems series capacitors are connected in series with the transmission line to reduce the effect of inductive reactance X_L between the sending end and receiving end of the line.
- ✘ One of the major drawbacks of series capacitors is that high over voltages are produced across the capacitor terminals under short circuit condition.
- ✘ Series capacitors are usually employed for increasing the power transfer capability of the transmission line and not for voltage regulation

SHUNT COMPENSATION

- Voltage Control by Shunt reactors
- Voltage Control by Shunt Capacitors
- Voltage Control by Static Shunt Compensation

VOLTAGE CONTROL BY SHUNT REACTORS

- ✘ Shunt reactors are provided at sending end and receiving end of the long EHV and UHV transmission lines.
- ✘ They are switched in when the line is to be charged or during line is on low load
- ✘ When the line is on no load or low load, shunt capacitance predominates and receiving end voltage is higher than the sending end voltage. This phenomenon is called *Ferranti effect*.
- ✘ The receiving end voltage of 400kV, 1000 km long line may be as high as 800kV. The shunt capacitance of such lines is neutralized by switching in the shunt reactor.
- ✘ During high loads, the series inductive reactance of the line produces IX_L drop and the receive end voltage drops, the shunt reactors are switched off Shunt treactors may be connected to the low voltage tertiary winding of a transformer via a suitable circuit breaker, EHV shunt reactors may be connected to the transmission line without any circuit breaker.

VOLTAGE CONTROL BY SHUNT CAPACITORS

- ✘ Shunt capacitors are usually switched in during high loads.
- ✘ Static shunt capacitors are installed near the load terminals, in industries, substations, ... Most of the industrial loads (induction motors, transformers, welding sets, furnaces) draws inductive current of poor power factor (0.3 to 0.6 lag).
- ✘ The shunt capacitors provide leading VARs there by the total KVA loading of substation transformer and the current is reduced.
- ✘ Thereby IX_L drop in the line is reduced and voltage regulation is improved.
- ✘ Shunt capacitors are switched in when KVA demand on the distribution line goes up and voltage on the bus comes down.
- ✘ Switching in shunt capacitor should improve the bus voltage if the compensation is effective

VOLTAGE CONTROL BY STATIC SHUNT COMPENSATION

- ✘ A step-less variable compensation is possible by thyristorized control of shunt capacitor and reactors.
- ✘ During heavy loads, the thyristors of the capacitor control are made to conduct for longer duration in each cycle.
- ✘ During low loads, the thyristors in reactor circuit are made to conduct for longer duration in each cycle.
- ✘ Thus a step-less variation of shunt compensation is achieved by means of static shunt compensation

SUB-SYNCHRONOUS RESONANCE PROBLEM

- ✘ When the electrical system operates in such a manner that the rotating fields in the generator due to sub-synchronous currents produce torques of the same frequency as one of the mechanical torsional frequencies of the shaft and of the correct phase, torques up to 10 times the break away or ultimate strength of the shaft can be reached resulting in shaft damage.
- ✘ This phenomenon of electromechanical interaction between electrical resonant circuits of the transmission system and the torsional natural frequencies of the T-G rotor is known as "Sub-Synchronous Resonance", and designated SSR.
- ✘ Three distinct problems have been identified in SSR problem which are called
 - Induction Generator Effect,
 - Torsional Interaction, and
 - Transient Torque Problem.

INDUCTION GENERATOR EFFECT

- ✘ An oscillation of generator rotor due to disturbances produces two components of currents or voltages.
- ✘ To the super synchronous component the generator is an induction motor. To the subsynchronous component the generator is an induction generator.
- ✘ At resonant electrical frequency f , below the synchronous frequency, the apparent, generator rotor resistance is negative. The equivalent resistance contains a term R/s where R is the effective rotor resistance and ' s ' is the slip. If this apparent negative resistance exceeds the network resistance i.e., when the system resistance is negative, the subsynchronous component will be amplified with time.
- ✘ Such a condition will result in self excitation of oscillatory currents at the resonant frequency. The phenomenon is known as induction generator effect.

TORSIONAL INTERACTION

- ✘ When the rotor field flux which rotates at the speed of the rotor, overtakes the more slowly rotating positive sequence subsynchronous flux of the-rotor, a subsynchronous oscillatory component of electrical torque is produced whose frequency is the difference between f_r and f_s , If this torque frequency coincides with or in close to a rotational modal frequency f_n , of the shaft system a regenerative feed back saturation may arise.
- ✘ If the enhanced subsynchronous electrical torque exceeds the inherent mechanical damping of the rotating system, the system will become self excited.
- ✘ This interplay between electrical and the mechanical system is called the torsional interaction

METHODS OF ANALYSIS

- ✘ Methods of analysis of SSR The various methods available in the frequency domain to analyse the phenomenon of SSR are:
 - Routh- hurwitz stability criteria
 - Frequency scanning techniques and
 - Eigen value analysis.

COUNTER MEASURES

- ✘ Remedy for Countering Induction Generator Effect:
 - ✓ Addition of pole-face
 - ✓ Addition of series reactance in stator circuit
 - ✓ System switching and unit tripping
 - ✓ Armature-current relay protection
- ✘ Remedy for Countering Torsional Interaction
 - ✓ Dynamic Stabilizer
 - ✓ Reduction in Series-Capacitor Compensation or Complete Removal
 - ✓ Filters

COUNTER MEASURES-2

- ✘ Remedy for Countering Transient Torque Problem.
 - Filtering and Damping: These utilize
 - (a) Static Blocking Filter,
 - (b) Line Filter,
 - (c) Bypass Damping Filter,
 - (d) Dynamic Filter,
 - (e) Dynamic Stabilizer,
 - (f) Excitation System Damper.
 - Relaying and Detecting: These are
 - (a) Torsional Motion Relay,
 - (b) Armature Current Relay,
 - (c) Torsional Monitor.
 - System Switching and Unit Tripping.
 - Modification to Generator and System: These include
 - (a) T-G modifications for new units altering stiffness, inertia and damping of rotors,
 - (b) Generator Series Reactance,
 - (c) Pole-Face Amortisseur Winding.
 - Removal or Short-Circuiting the Series Capacitor

THANK YOU