



# ROBOTICS

Course code:AME533

III. B.Tech II semester

Regulation: IARE R-16

BY

Mr. A Anudeep Kumar

Assistant Professor

DEPARTMENT OF MECHANICAL ENGINEERING  
INSTITUTE OF AERONAUTICAL ENGINEERING

(Autonomous)

DUNDIGAL, HYDERABAD - 500 043

CO's	Course outcomes
CO1	Understand characteristic features of robots and usage of different grippers for industrial applications.
CO2	Understand direct and inverse kinematics of robot structure.
CO3	Illustrate Differential Kinematics of planar and spherical manipulators.
CO4	Understand classification of robot actuators and trajectory planning.
CO5	Remember material handling and applications in manufacturing.



# UNIT- I

## INTRODUCTION TO ROBOTICS

CLOs	Course Learning Outcome
CLO1	Differentiate between automation and robotics.
CLO2	Classify robots and describe its anatomy.
CLO3	Specify various types of industrial sensors.
CLO4	Classify various grippers.

- **Automation as a technology that is concerned with the use of mechanical, electronic, and computer-based systems in the operation and control of production.**
- **Examples for automation are:**
  - a) **Transfer lines.**
  - b) **Mechanized assembly machines.**
  - c) **Feedback control systems.**
  - d) **Numerically controlled machine tools and**
  - e) **Robots.**

- **There are three broad classes of industrial automation:**
  - a) **Fixed automation.**
  - b) **Programmable automation.**
  - c) **Flexible automation.**

# Fixed Automation

- Here equipment's are used to automate the processes in orderly manner:
- Low cost.
- High production rate.
- Inflexible design.



- Here equipment's are designed to accommodate the changes made in the system design, whole sequence is controlled by a program.
- Suitable for batch production.
- Low production rate.
- Flexible with product design.





- It is an extension of programmable automation which is designed to manufacture a variety of products with no loss of time.
- Medium production rate.
- Continuous production with variable designs.
- High investment.



- **“Robot”** coined by Karel Capek in a 1921 science-fiction Czech play
- **Robot** - Mechanical device that performs human tasks, either automatically or by remote control.
- **Robotics** - Study and application of robot technology.
- **Telerobotics** - Robot that is operated remotely.

# Laws of Robotics

➤ **Asimov proposed three “Laws of Robotics”**

**Law 1: A robot may not injure a human being or through inaction, allow a human being to come to harm.**

**Law 2: A robot must obey orders given to it by human beings, except where such orders would conflict with the first law.**

**Law 3: A robot must protect its own existence**

# Ideal Tasks

➤ Tasks which are:

## A. Dangerous

- a) Space exploration
- b) chemical spill cleanup
- c) disarming bombs
- d) disaster cleanu

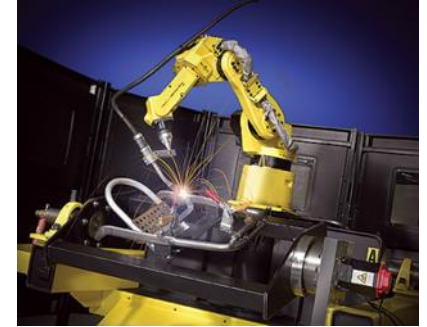

## B. Boring and/or repetitive

- a) Welding car frames
- b) part pick and place
- c) manufacturing parts.



# Robotics Timeline

- **1922 Czech author Karel Capek wrote a story called Rossum's Universal Robots and introduced the word "Rabota" (meaning worker).**
- **1954 George Devol developed the first programmable Robot.**
- **1955 Denavit and Hartenberg developed the homogenous transformation matrices**
- **1962 Unimation was formed, first industrial Robots appeared.**

- **Defined by Robotics Industry Association (RIA) as**
  - A re-programmable, multifunctional manipulator designed to move material, parts, tools or specialized devices through variable programmed motion for a variety of tasks.**
- **possess certain anthropomorphic characteristics.**
  - a) mechanical arm.**
  - b) sensors to respond to input.**
  - c) Intelligence to make decisions.**

- **Actuators** : Actuators are the muscles of the manipulators. Common types of actuators are servomotors, stepper motors, pneumatic cylinders etc.
- **Sensors** : Sensors are used to collect information about the internal state of the robot or to communicate with the outside environment. Robots are often equipped with external sensory devices such as a vision system, touch and tactile sensors etc which help to communicate with the environment
- **Controller** : The controller receives data from the computer, controls the motions of the actuator and coordinates these motions with the sensory feedback information.

## Evaporator:

- **Cartesian/Rectangular Gantry(3P) :** These Robots are made of 3 Linear joints that orient the end effector, which are usually followed by additional revolute joints.

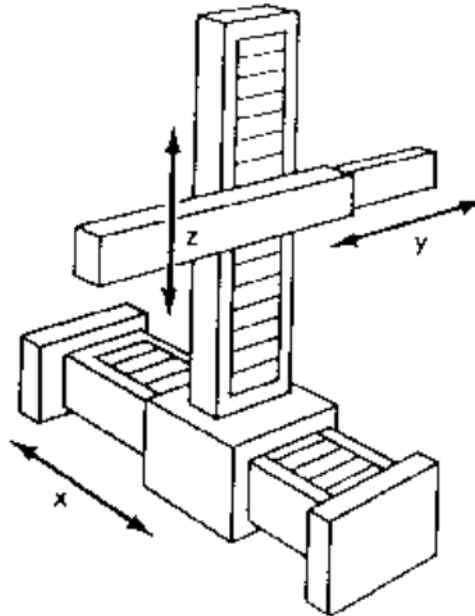



# Cartesian Robot - Work Envelope

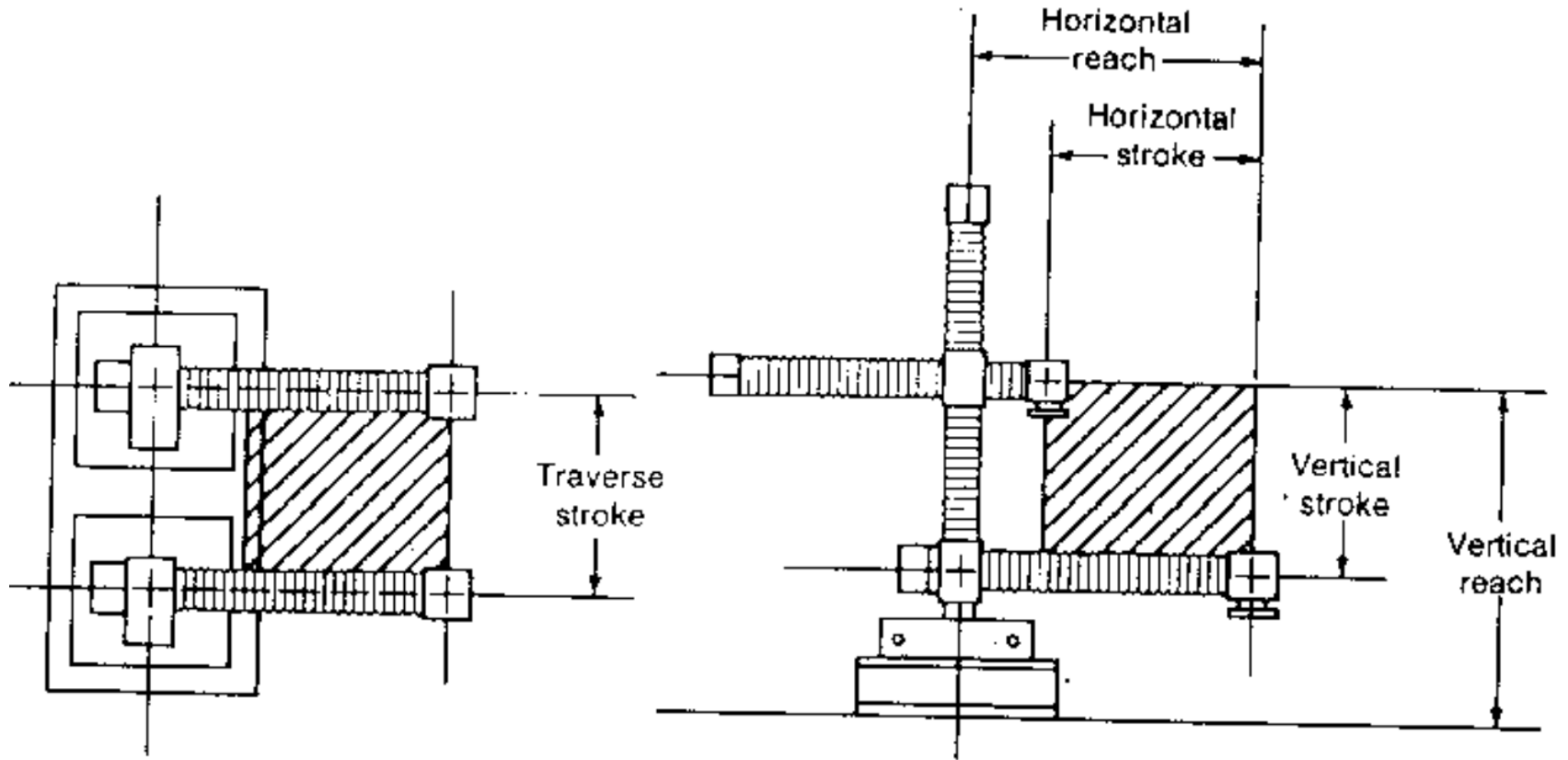

- Cylindrical coordinate Robots have 2 prismatic joints and one revolute joint.

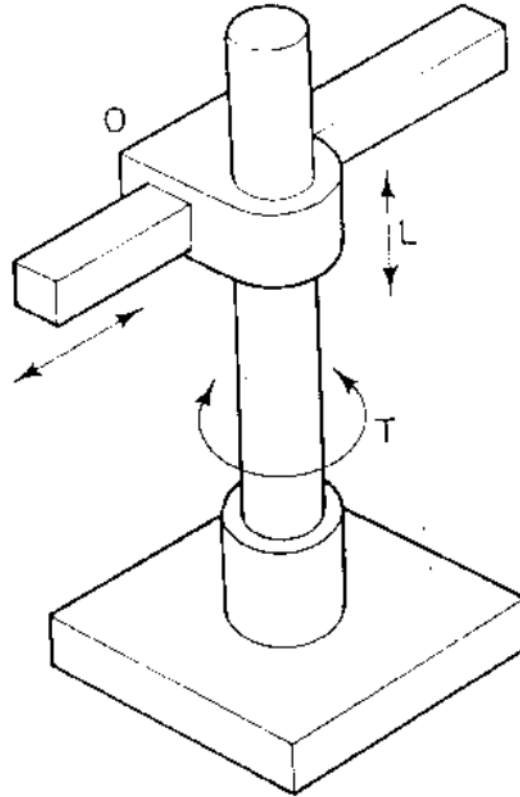

# Cylindrical Robot - Work Envelope

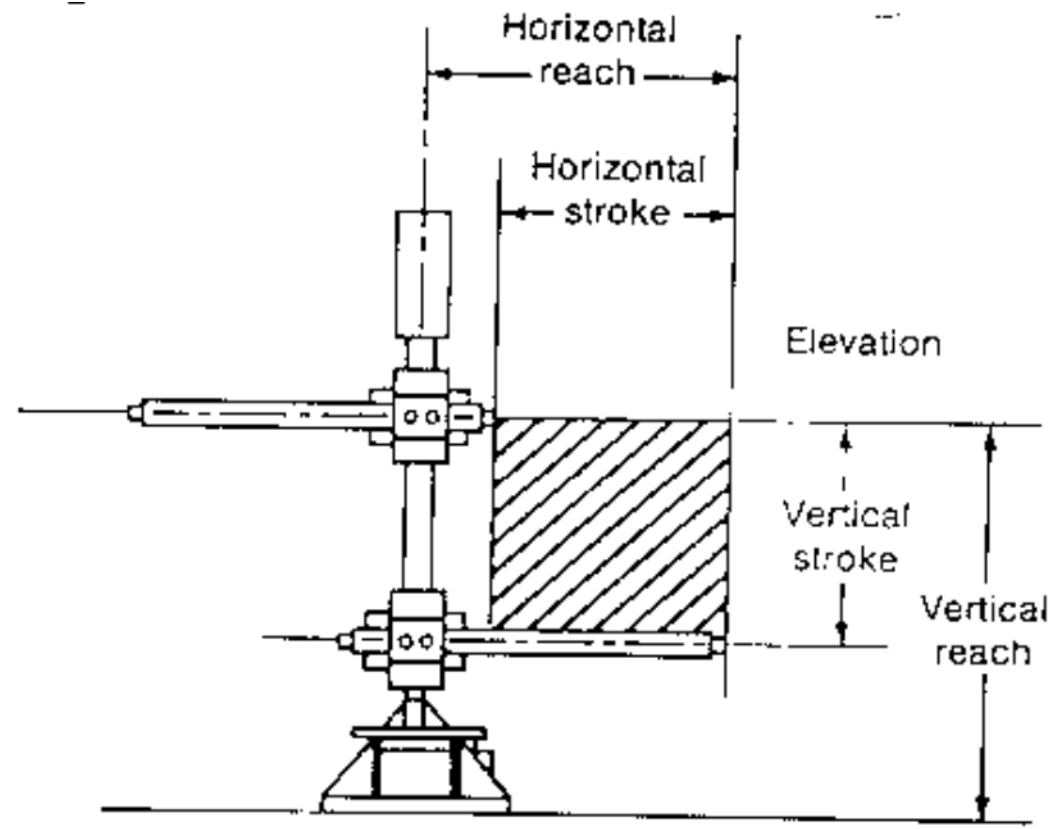
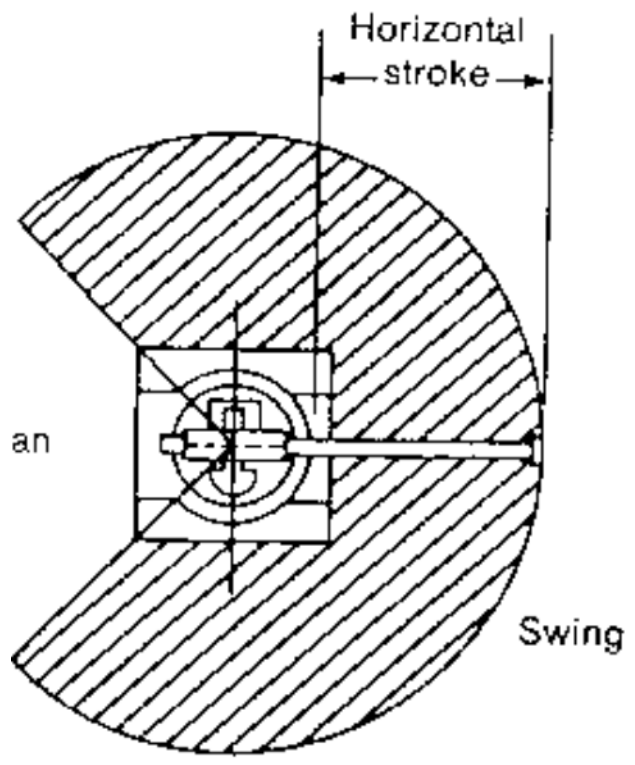

# Spherical Robot:

- They follow a spherical coordinate system.

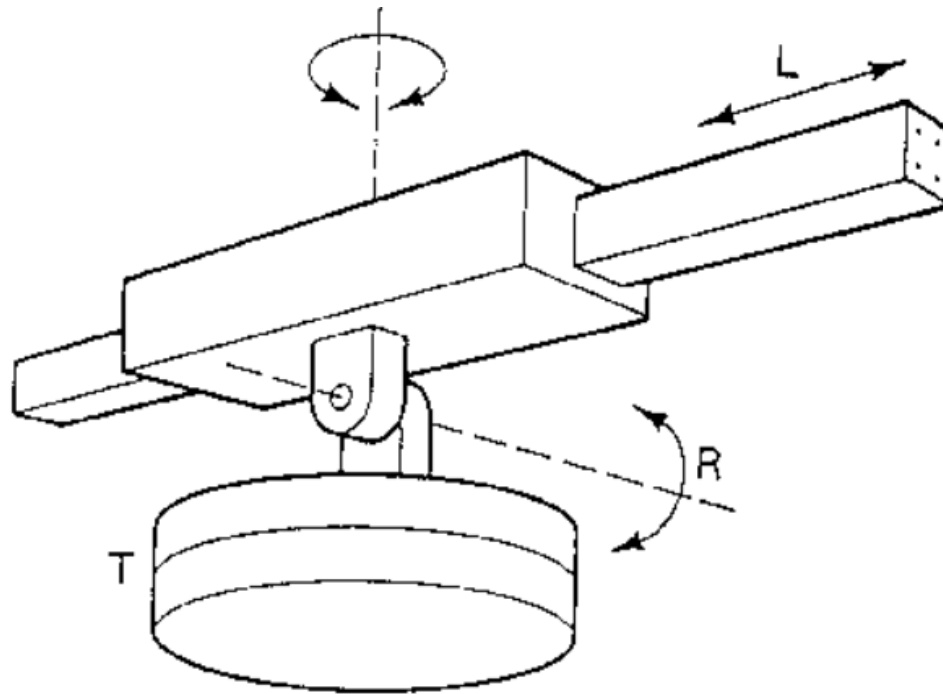

# Spherical Robot - Work Envelope

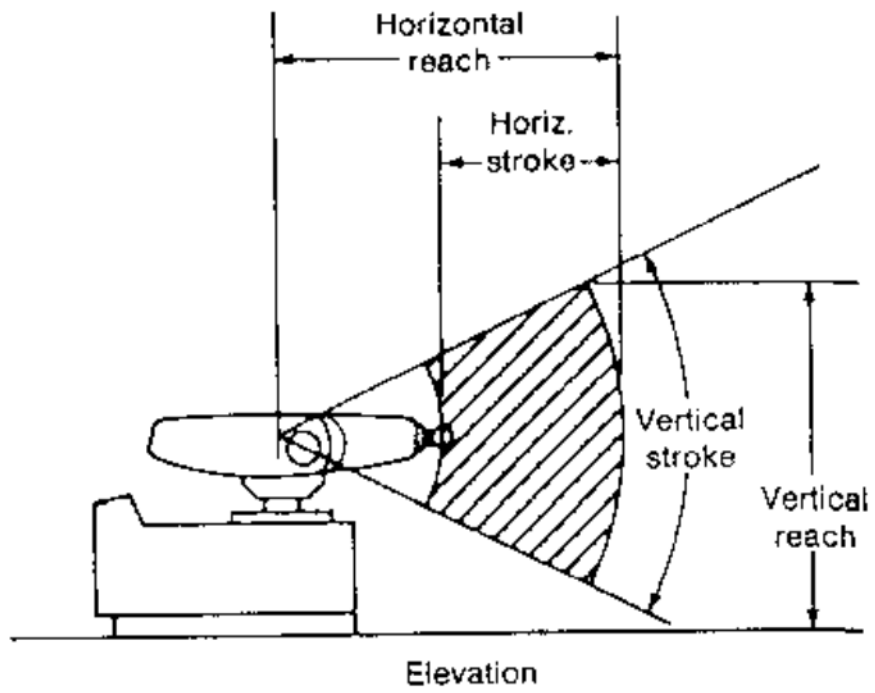
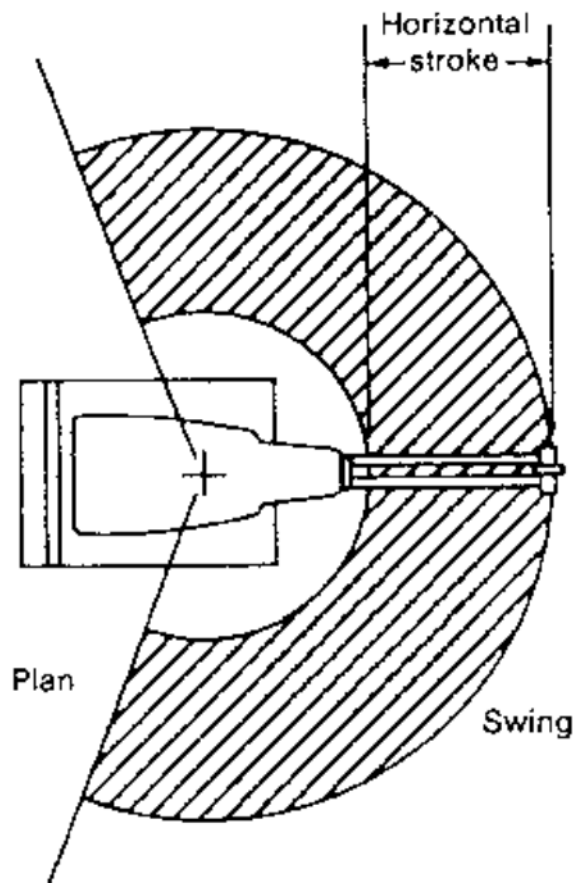

# Articulated Robot:

- An articulated robot's joints are all revolute, similar to a human's arm.

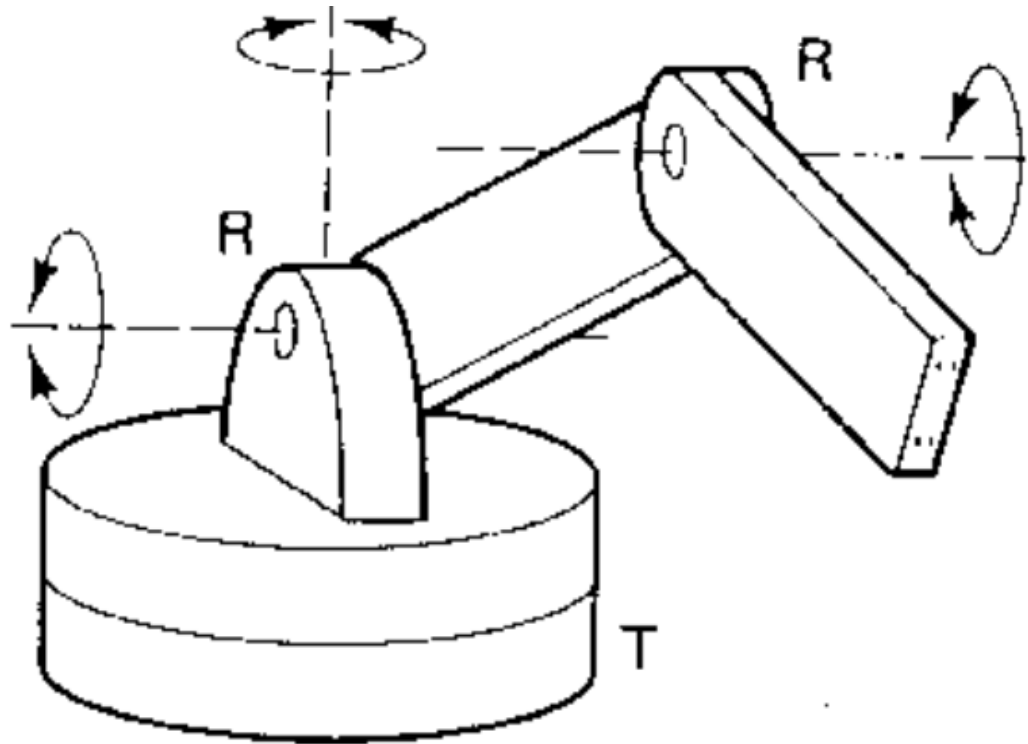

- **Selective Compliance Assembly Robot Arm (SCARA):** They have two revolute joints that are parallel and allow the Robot to move in a horizontal plane, plus an additional prismatic joint that moves vertically.

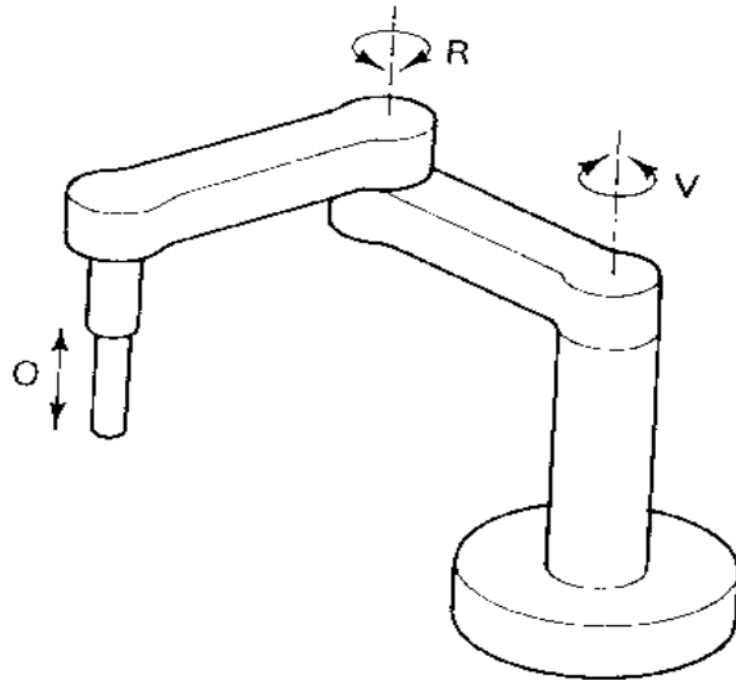

# Work Envelope concept

- Depending on the configuration and size of the links and wrist joints, robots can reach a collection of points called a **Workspace**.
- Alternately **Workspace** may be found empirically, by moving each joint through its range of motions and combining all space it can reach and subtracting what space it cannot reach



- **Typically robot manipulator has 3 degrees of freedom**
  - a) **Roll involves rotating the wrist about the arm axis**
  - b) **Pitch up-down rotation of the wrist**
  - c) **Yaw left-right rotation of the wrist**
- **End effector is mounted on the wrist**

# WRIST MOTIONS

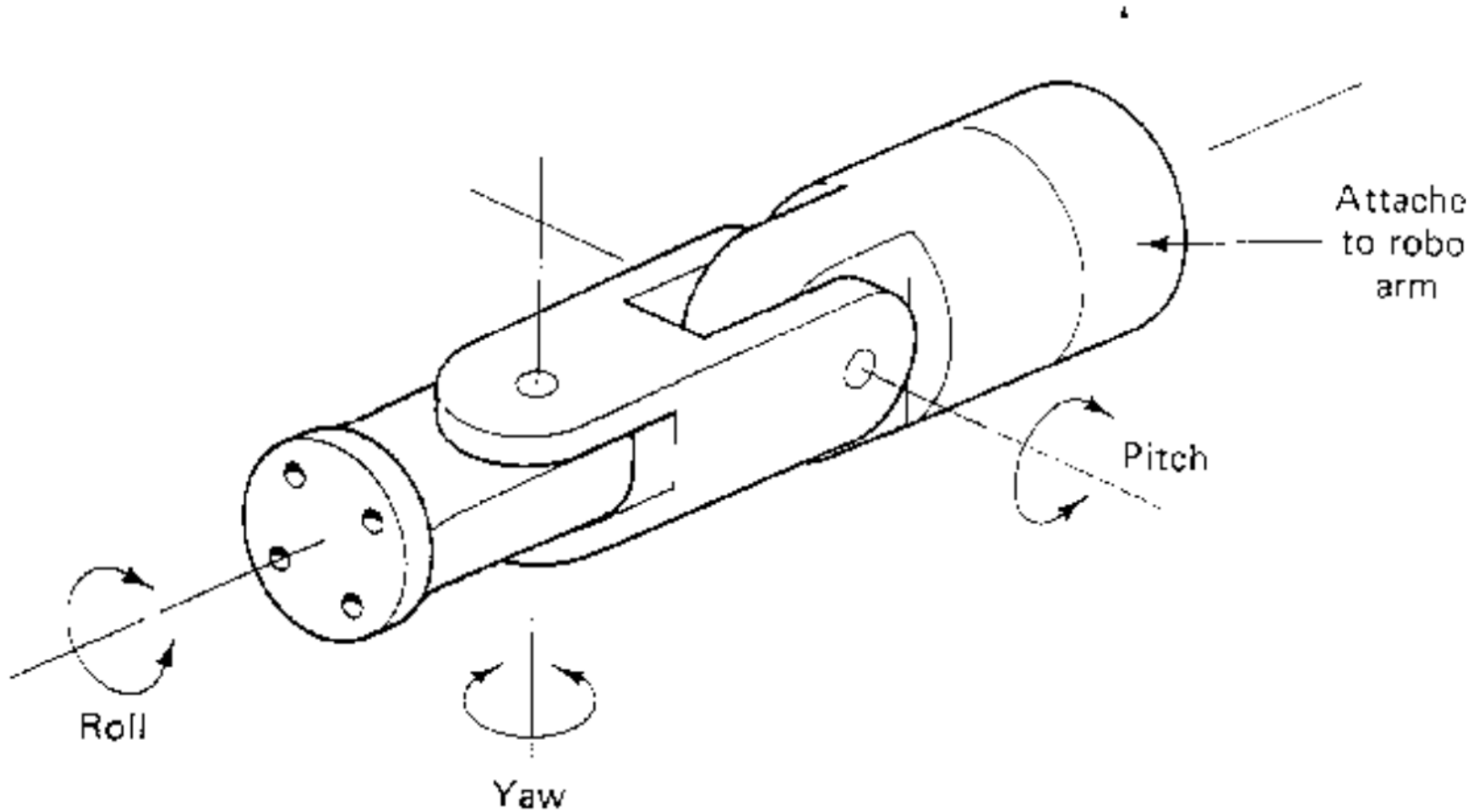

## Non Servo Control

- **implemented by setting limits or mechanical stops for each joint and sequencing the actuation of each joint to accomplish the cycle**
- **end point robot, limited sequence robot, bang-bang robot**
- **No control over the motion at the intermediate points, only end points are known**

## Servo Control

- **Point to point Control**
- **Continuous Path Control**
- **Closed Loop control used to monitor position, velocity (other variables) of each joint**

- **Only the end points are programmed, the path used to connect the end points are computed by the controller.**
- **user can control velocity, and may permit linear or piece wise linear motion.**
- **Feedback control is used during motion to ascertain that individual joints have achieved desired location.**

- **Often used hydraulic drives, recent trend towards servomotors**
- **loads up to 500lb and large reach**
- **Applications**
  - a) pick and place type operations**
  - b) palletizing**
  - c) machine loading**

- In addition to the control over the endpoints, the path taken by the end effector can be controlled
- Path is controlled by manipulating the joints throughout the entire motion, via closed loop control
- Applications:
  - spray painting, polishing, grinding, arc welding

- Typically performed using one of the following
  - On line
    - a) Teach pendant
    - b) Lead through programming
  - Off line
    - a) Robot programming languages
    - b) Task level programming



- **Hand held device with switches used to control the robot motions**
- **End points are recorded in controller memory**
- **Sequentially played back to execute robot actions**
- **Trajectory determined by robot controller**
- **Suited for point to point control applications**

# Use of Teach Pendant

- **Easy to use, no special programming skills required.**
- **Useful when programming robots for wide range of repetitive tasks for long production runs.**
- **RAPID.**

- **lead the robot physically through the required sequence of motions.**
- **trajectory and endpoints are recorded, using a sampling routine which records points at 60-80 times a second.**
- **when played back results in a smooth continuous motion.**
- **large memory requirements.**

- **Uses sensors for feedback.**
- **Closed-loop robots use sensors in conjunction with actuators to gain higher accuracy – servo motors.**
- **Uses include mobile robotics, telepresence, search and rescue, pick and place with machine vision.**

## ➤ Working volume

- a) The space within which the robot operates.
- b) Larger volume costs more but can increase the capabilities of a robot

## ➤ Speed and acceleration

- a) Faster speed often reduces resolution or increases cost
- b) Varies depending on position, load.
- c) Speed can be limited by the task the robot performs (welding, cutting)

# Sensory Measures of performance

- **Resolution**
- **Often a speed tradeoff**
- **The smallest step the robot can take**
- **Speed and acceleration**

# Sensory Measures of performance

## ➤ Accuracy

The difference between the actual position of the robot and the programmed position

Low accuracy, high repeatability:

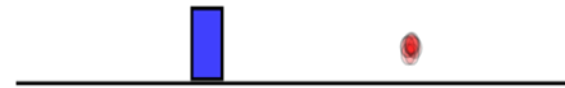

High accuracy, low repeatability:

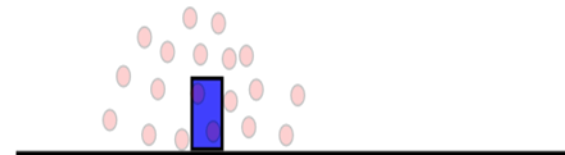

## ➤ Repeatability

## ➤ Increased cost

## ➤ Varies depending

on position, load

- **Actuator is the term used for the mechanism that drives the robotic arm.**
- **There are 3 main types of Actuators**
  - a) **Electric motors**
  - b) **Hydraulic**
  - c) **Pneumatic cylinder**
- **Hydraulic and pneumatic actuators are generally suited to driving prismatic joints since they produce linear motion directly**



- **Hydraulic and pneumatic actuators are also known as linear actuators.**
- **Electric motors are more suited to driving revolute joints as they produce rotation.**

# Robot End Effectors

- **Introduction**
- **Types of End effectors**
- **Mechanical gripper**
- **Types of gripper mechanism**
- **Gripper force analysis**
- **Other types of gripper**
- **Special purpose grippers**

# Robot End Effectors

- **Device that attaches to the wrist of the robot arm and enables the general-purpose robot to perform a specific task.**
- **Two Types**
  - Grippers – to grasp and manipulate objects (e.g., parts) during work cycle**
  - Tools – to perform a process, e.g., spot welding, spray painting**

# Unilateral vs Multilateral Gripper

- **Unilateral**– only one point or surface is touching the object to be handled.
- **Example** : vacuum pad gripper & Electro magnetic gripper
- **Multilateral** – more than two points or surfaces touching the components to be handled.

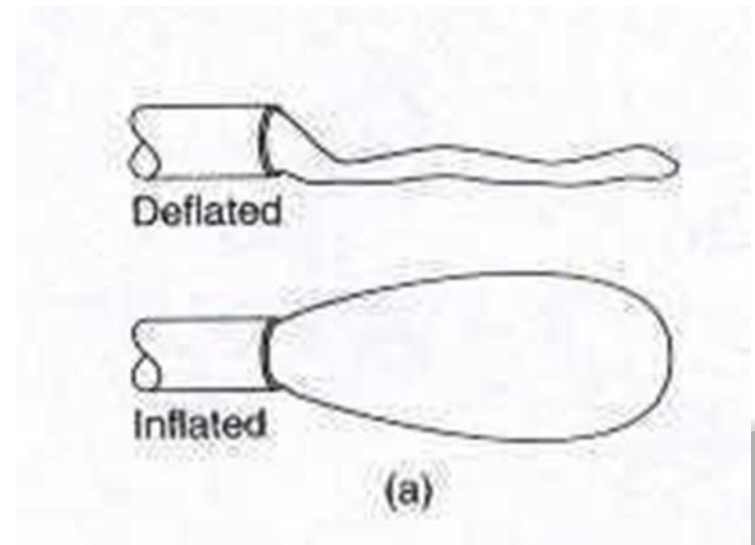
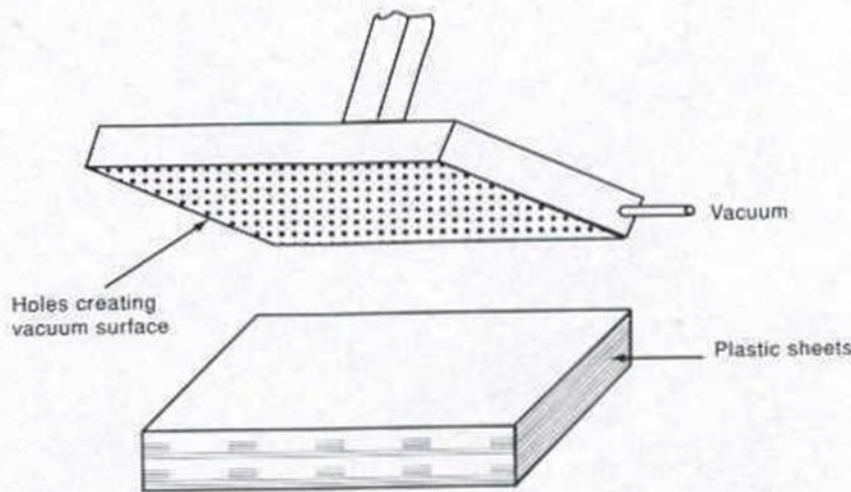

- **End-effector that holds or grasp an object (in assembly, pick and place operation and material handling) to perform some task.**
- **Four Major Types of gripper**
  1. **Mechanical**
  2. **Suction or vacuum cups**
  3. **Magnetized gripper**
  4. **Adhesives**

# Mechanical Gripper

- It is an end effector that uses mechanical fingers actuated by a mechanism to grasp an object.
- Two ways of constraining part in gripper
  1. Physical construction of parts within finger. Finger encloses the part to some extent and thereby designing the contact surface of finger to be in approximate shape of part geometry.

# Mechanical Gripper

2. Holding the part is by friction between fingers and workpart. Finger must apply force that is sufficient for friction to retain the part against gravity.

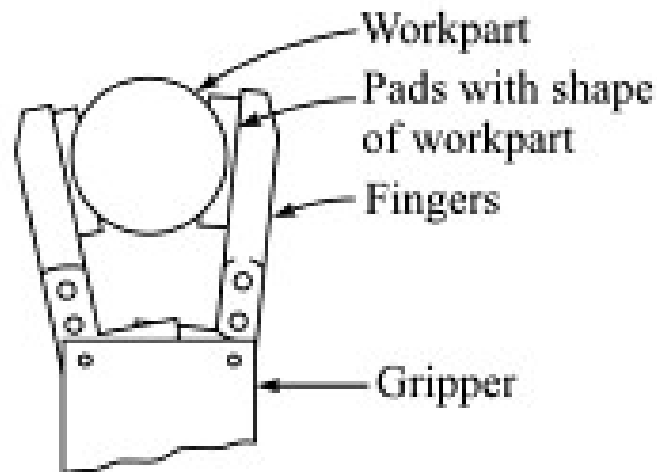

Fig. 5.2 *Physical constriction method of finger design.*

# Mechanical Gripper

To resist the slippage, the gripper must be designed to exert a force that depends on the weight of the part, coeff of friction and acceleration of part.

$$\mu n_f F_g = w \quad (5.1)$$

where  $\mu$  = coefficient of friction of the finger contact surface against the part surface

$n_f$  = number of contacting fingers

$F_g$  = gripper force

$w$  = weight of the part or object being gripped

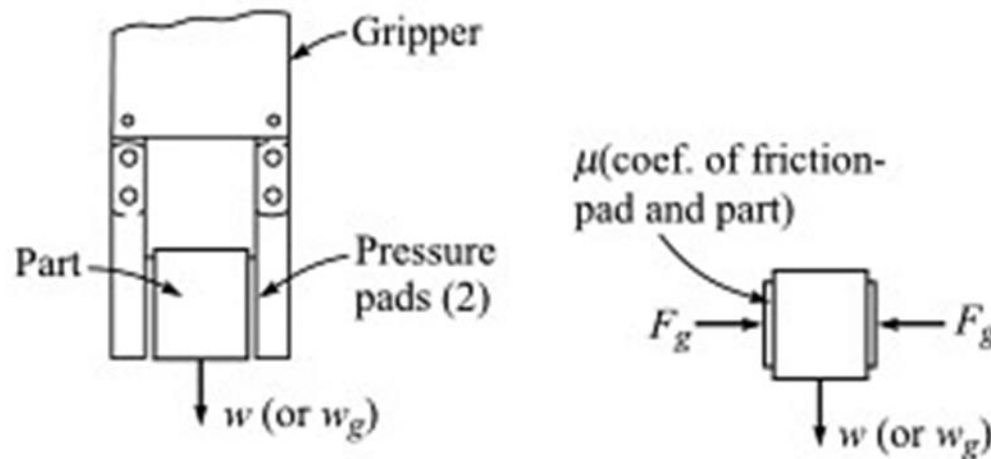



# Mechanical Gripper Mechanism

**Two ways of gripper mechanism based on finger movement**

- 1. Pivoting movement – Eg. Link actuation**
- 2. Linear or translational movement – Eg. Screw and cylinder**

**Four ways of gripper mechanism based on kinematic devices**

- 1. Linkage actuation**
- 2. Gear and rack actuation**
- 3. Cam actuation**
- 4. Screw actuation**

# Mechanical Gripper Mechanism

## 1. Linkage actuation

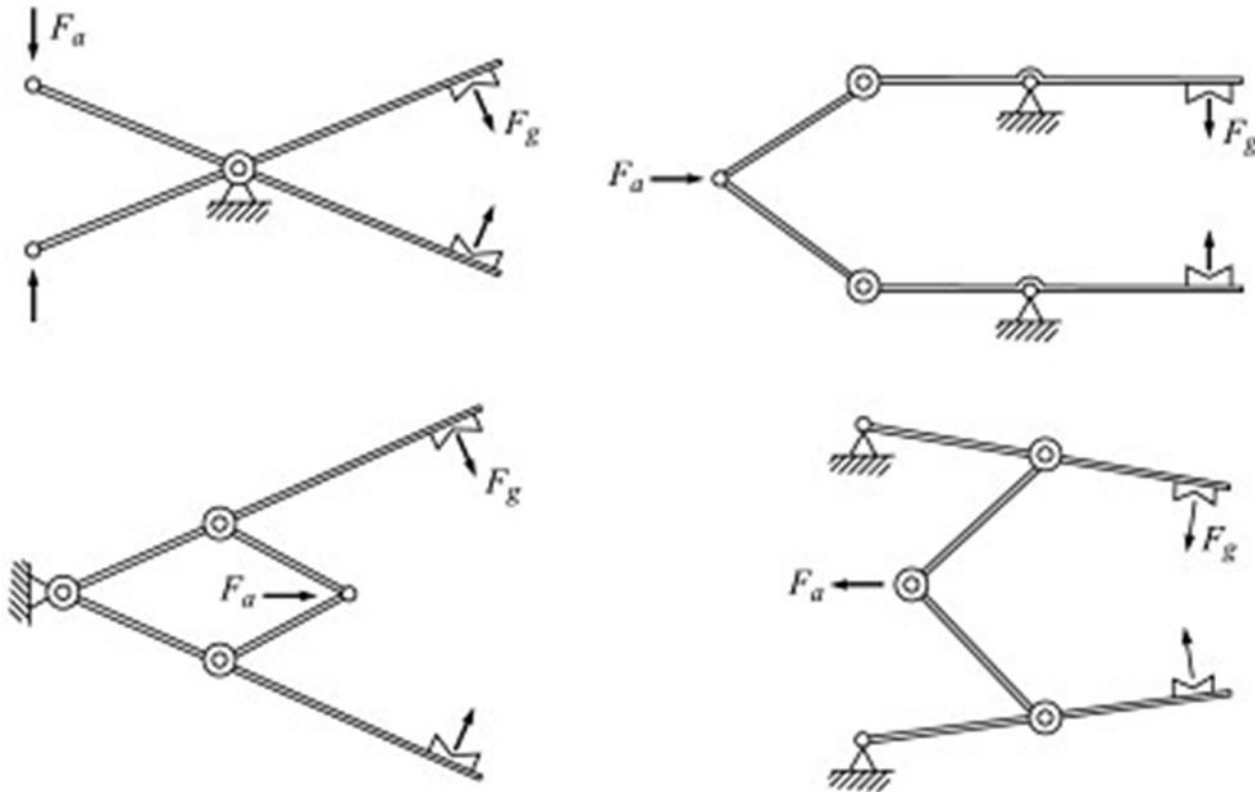

*Some possible linkages for robot grippers.*

# Mechanical Gripper Mechanism

## 2. Gear and rack actuation actuation

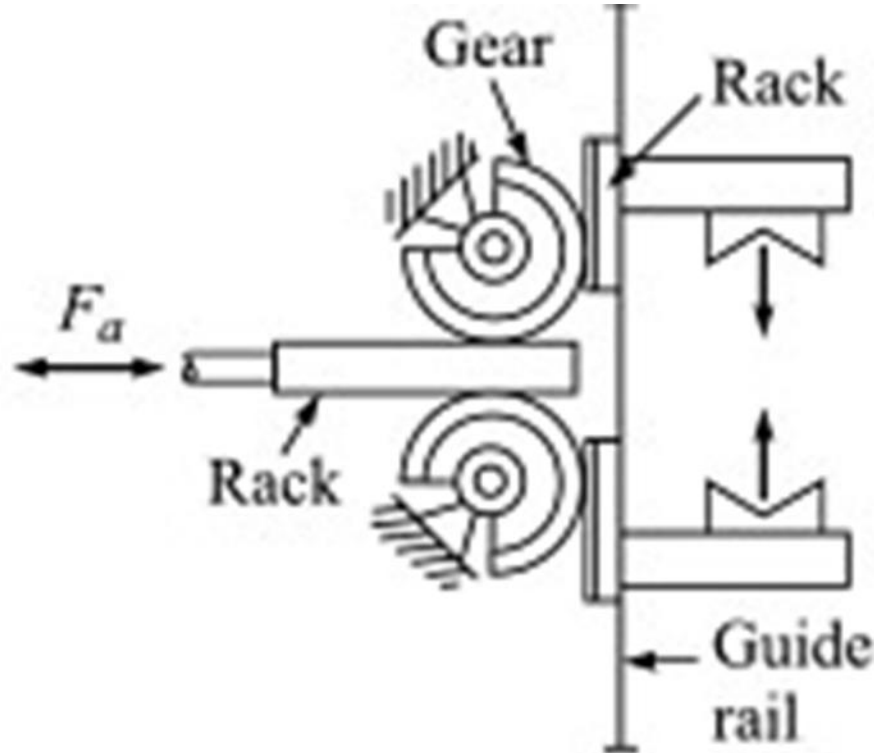

*Gear-and-rack method of actuating the gripper.*

# Mechanical Gripper Mechanism

## 3. Cam Actuation

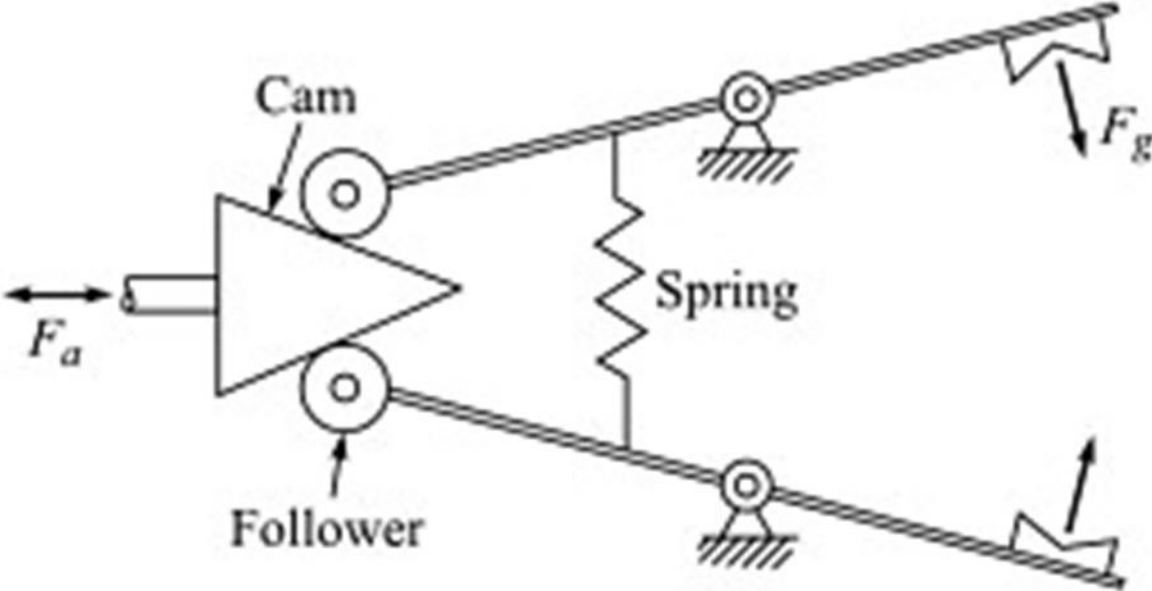

*Cam-actuated gripper.*

# Mechanical Gripper Mechanism

## 3. Screw actuation

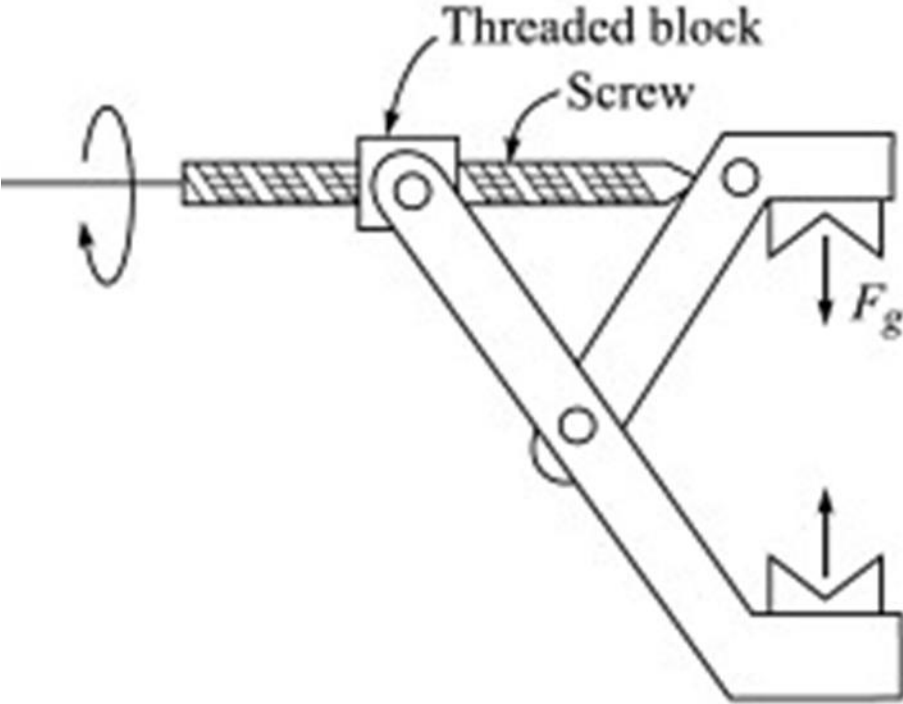

*Screw-type gripper actuation.*

# Hooks and Scoops

- **Hooks and scoops are the simplest type of end effectors that can be classes as grippers.**
- **A scoop or ladle is commonly used to scoop up molten metal and transfer it to the mould**
- **A hook may be all that is needed to lift a part especially if precise positioning in not required and if it is only to be dipped into a liquid.**
- **Hook are used to load and unload parts hanging from the overhead conveyors. The parts to be handled by a hook must have some sort of handle, eyebolt or ring to enable the hook to hold it.**

# Hooks and Scoops

- **Scoops are used for handling the materials in liquid or power from, the limitation of scoop is, it is difficult to control the amount of martial being handled by the scoop. In addition, spilling of the material during handling is another problem.**

# Magnetic Grippers

- **Magnetic grippers obviously only work on magnetic objects and therefore are limited in working with certain metals.**
- **For maximum effect the magnet needs to have complete contact with the surface of the metal to be gripped. Any air gaps will reduce the strength of the magnetic force, therefore flat sheets of metal are best suited to magnetic grippers.**
- **If the magnet is strong enough, a magnetic gripper can pick up an irregular shaped object. In some cases the shape of the magnet matches the shape of the object**



- A disadvantage of using magnetic grippers is the temperature. Permanent magnets tend to become demagnetized when heated and so there is the danger that prolonged contact with a hot work piece will weaken them to the point where they can no longer be used. The effect of heat will depend on the time the magnet spends in contact with the hot part. Most magnetic materials are relatively unaffected by temperatures up to around 100 degrees.
- Electromagnets can be used instead and are operated by a DC electric current and lose nearly all of their magnetism when the power is turned off.
- Permanent magnets are also used in situations where there is an explosive atmosphere and sparks from electrical equipment would cause a hazard.

- A disadvantage of using magnetic grippers is the temperature. Permanent magnets tend to become demagnetized when heated and so there is the danger that prolonged contact with a hot work piece will weaken them to the point where they can no longer be used. The effect of heat will depend on the time the magnet spends in contact with the hot part. Most magnetic materials are relatively unaffected by temperatures up to around 100 degrees.
- Electromagnets can be used instead and are operated by a DC electric current and lose nearly all of their magnetism when the power is turned off.
- Permanent magnets are also used in situations where there is an explosive atmosphere and sparks from electrical equipment would cause a hazard.

# Expandable Bladder Type Grippers

- A bladder gripper or bladder hand is a specialized robotic end effector that can be used to grasp, pick up, and move rod-shaped or cylindrical objects.
- The main element of the gripper is an inflatable, donut-shaped or cylindrical sleeve that resembles the cuff commonly used in blood pressure measuring apparatus.
- The sleeve is positioned so it surrounds the object to be gripped, and then the sleeve
- is inflated until it is tight enough to accomplish the desired task.
- The pressure exerted by the sleeve can be measured and regulated using force sensors.

# Expandable Bladder Type Grippers

- Bladder grippers are useful in handling fragile objects. However, they do not operate fast, and they can function only with objects within a rather narrow range of physical sizes.

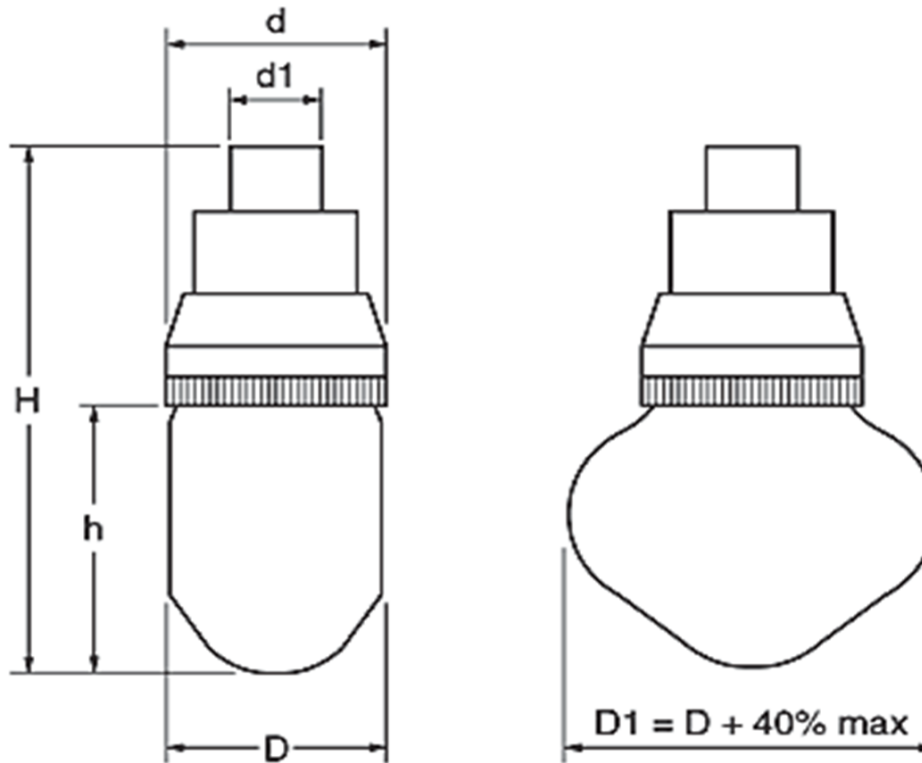

# Adhesive Grippers

- **Adhesive Substance can be used for grasping action in adhesive grippers.**
- **In adhesive grippers, the adhesive substance loses its tackiness due to repeated usage. This reduces the reliability of the gripper. In order to overcome this difficulty, the adhesive material is continuously fed to the gripper in the form of ribbon by feeding mechanism.**

# Adhesive Grippers

- **A major asset of the adhesive gripper is the fact that it is simple. As long as the adhesive keep its stickiness it will continue to function without maintenance, however, there are certain limitations, the most significant is the fact that the adhesive cannot readily be disabled in order to release the grasp on an object. Some other means, such as devices that lock the gripped object into place, must be used.**
- **The adhesive grippers are used for handling fabrics and other lightweight materials.**



# UNIT II

## MOTION ANALYSIS

CLOs	Course Learning Outcome
CLO5	Discuss about motion analysis of robot.
CLO6	Understand methods for calculating the kinematics and inverse kinematics of a robot manipulator.
CLO7	Describe D-H notations, joint coordinates and. world coordinates.
CLO8	Discuss about homogeneous transformation.



- **Forward Kinematics (angles to position).**
  - a) **The length of each link.**
  - b) **The angle of each joint.**
- **The position of any point (i.e. it's  $(x, y, z)$  coordinates.**
- **Inverse Kinematics (position to angles).**
  - a) **The length of each link.**
  - b) **The position of some point on the robot.**
- **The angles of each joint needed to obtain that position.**

## ➤ Matrix Multiplication:

An  $(m \times n)$  matrix  $A$  and an  $(n \times p)$  matrix  $B$ , can be multiplied since the number of columns of  $A$  is equal to the number of rows of  $B$ .

## ➤ Non-Commutative Multiplication

$AB$  is NOT equal to  $BA$

$$\begin{bmatrix} a & b \\ c & d \end{bmatrix} * \begin{bmatrix} e & f \\ g & h \end{bmatrix} = \begin{bmatrix} (ae + bg) & (af + bh) \\ (ce + dg) & (cf + dh) \end{bmatrix}$$

# Matrix Addition:

$$\begin{bmatrix} a & b \\ c & d \end{bmatrix} + \begin{bmatrix} e & f \\ g & h \end{bmatrix} = \begin{bmatrix} (a+e) & (b+f) \\ (c+g) & (d+h) \end{bmatrix}$$

# Basic Transformations

- Moving Between Coordinate Frames.  
Translation Along the X-Axis

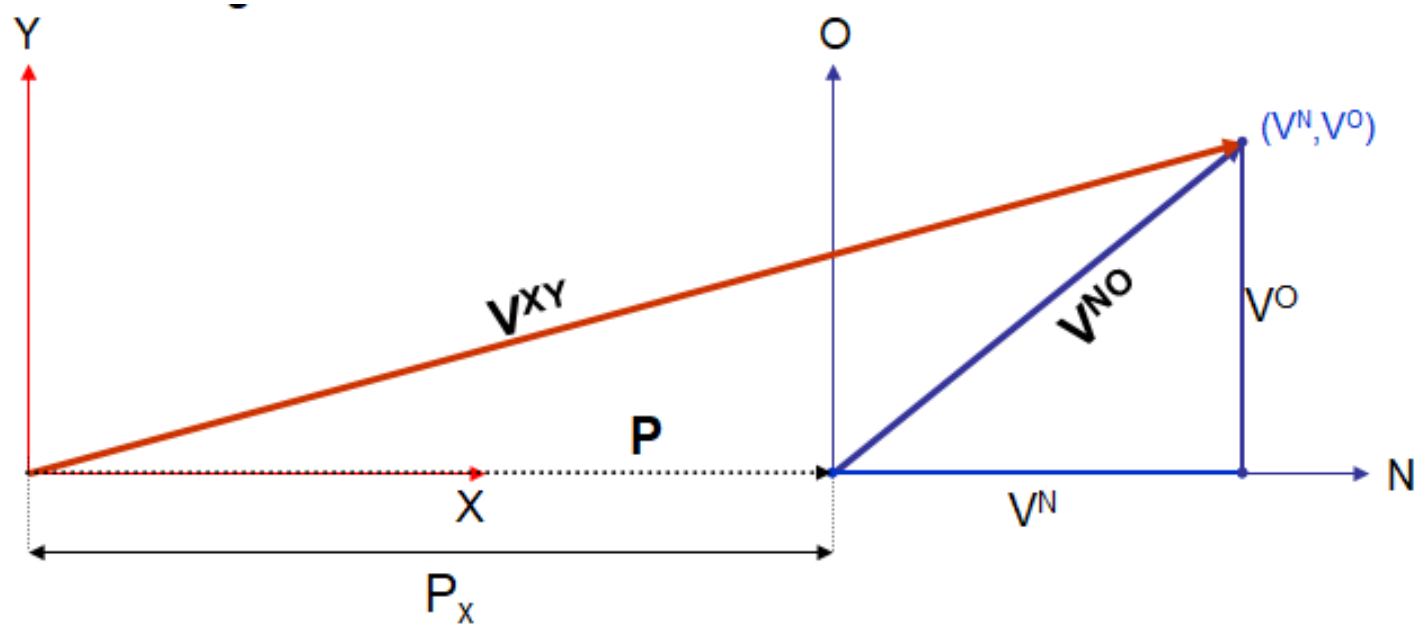

# Basic Transformations

$P_x$  = distance between the XY and NO coordinate planes

**Notation:**  $\bar{V}^{XY} = \begin{bmatrix} V^X \\ V^Y \end{bmatrix}$      $\bar{V}^{NO} = \begin{bmatrix} V^N \\ V^O \end{bmatrix}$      $\bar{P} = \begin{bmatrix} P_x \\ 0 \end{bmatrix}$

# Basic Transformations

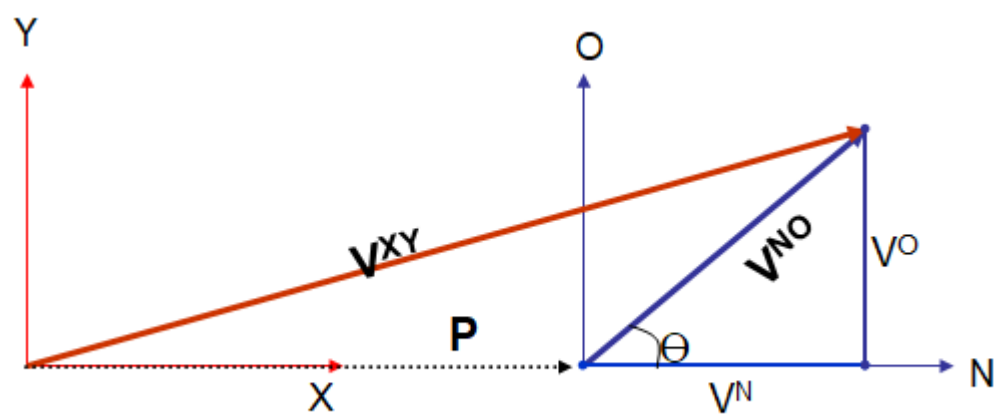

$$\bar{V}^{XY} = \begin{bmatrix} \mathbf{P}_X + V^N \\ V^O \end{bmatrix} = \bar{\mathbf{P}} + \bar{V}^{NO}$$

# Translation along the X-Axis and Y-Axis

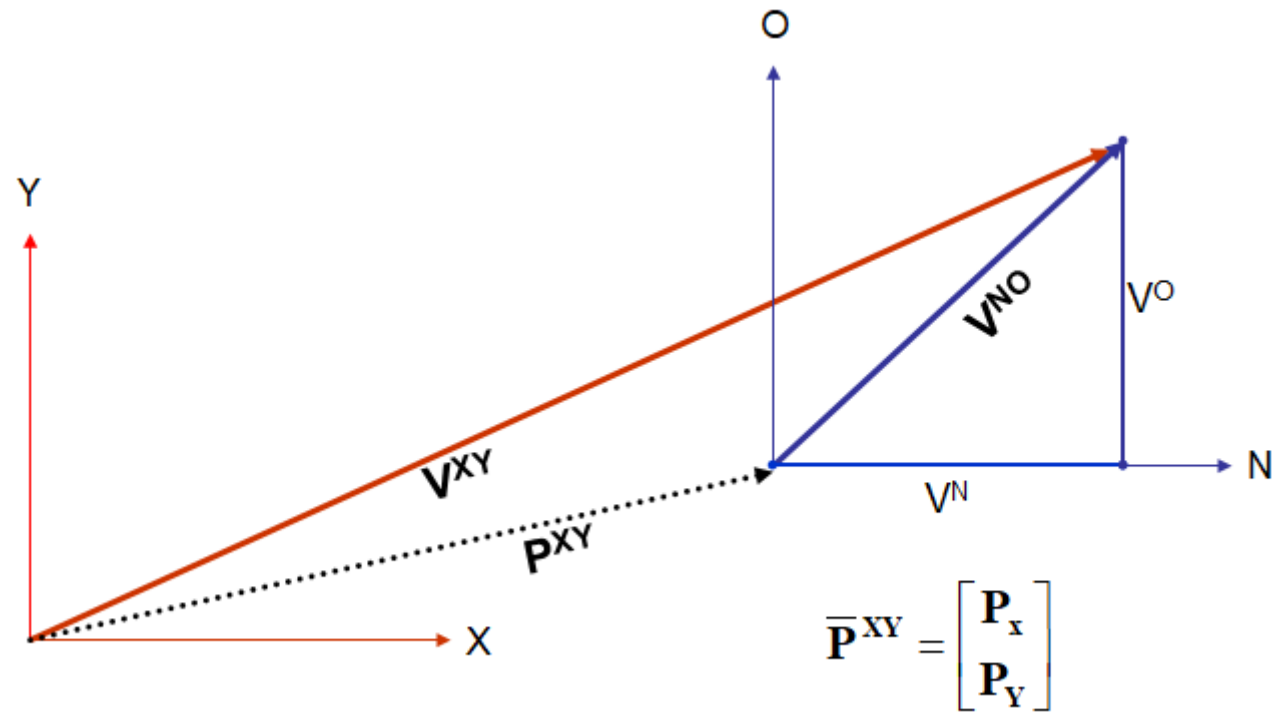

$$\bar{\mathbf{P}}^{XY} = \begin{bmatrix} \mathbf{P}_x \\ \mathbf{P}_y \end{bmatrix}$$

$$\bar{\mathbf{V}}^{XY} = \begin{bmatrix} \mathbf{P}_x + \mathbf{V}^N \\ \mathbf{V}^O \end{bmatrix} = \bar{\mathbf{P}} + \bar{\mathbf{V}}^{NO}$$

# Basis Vectors

Basis vectors are unit vectors that point along a coordinate axis

$\bar{\mathbf{n}}$  Unit vector along the N-Axis

$\bar{\mathbf{o}}$  Unit vector along the N-

Axis  
 $\|\mathbf{V}^{NO}\|$  Magnitude of the  $\mathbf{V}^{NO}$  vector

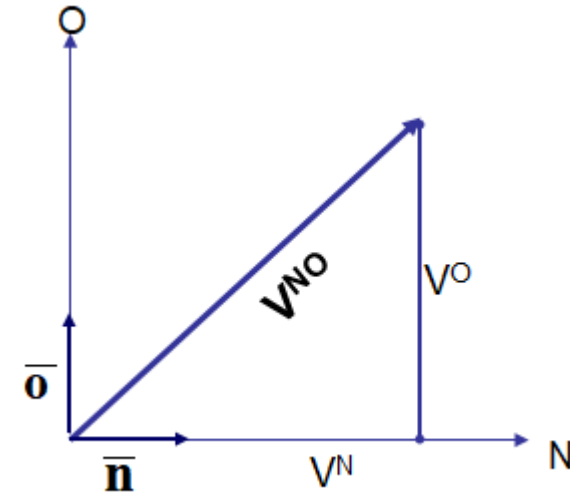

$$\bar{\mathbf{V}}^{NO} = \begin{bmatrix} V^N \\ V^O \end{bmatrix} = \begin{bmatrix} \|\mathbf{V}^{NO}\| \cos\theta \\ \|\mathbf{V}^{NO}\| \sin\theta \end{bmatrix} = \begin{bmatrix} \|\mathbf{V}^{NO}\| \cos\theta \\ \|\mathbf{V}^{NO}\| \cos(90 - \theta) \end{bmatrix} = \begin{bmatrix} \bar{\mathbf{V}}^{NO} \bullet \bar{\mathbf{n}} \\ \bar{\mathbf{V}}^{NO} \bullet \bar{\mathbf{o}} \end{bmatrix}$$



# Basis Vectors

Basis vectors are unit vectors that point along a coordinate axis

$\bar{\mathbf{n}}$  Unit vector along the N-Axis

$\bar{\mathbf{o}}$  Unit vector along the N-

Axis  
 $\|\mathbf{V}^{NO}\|$  Magnitude of the  $\mathbf{V}^{NO}$  vector

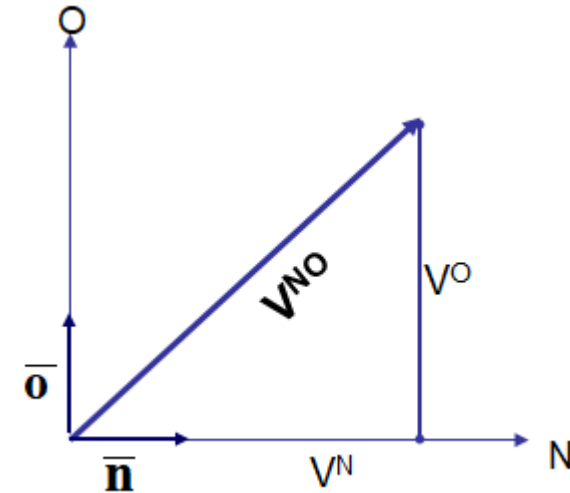

$$\bar{\mathbf{V}}^{NO} = \begin{bmatrix} V^N \\ V^O \end{bmatrix} = \begin{bmatrix} \|\mathbf{V}^{NO}\| \cos\theta \\ \|\mathbf{V}^{NO}\| \sin\theta \end{bmatrix} = \begin{bmatrix} \|\mathbf{V}^{NO}\| \cos\theta \\ \|\mathbf{V}^{NO}\| \cos(90 - \theta) \end{bmatrix} = \begin{bmatrix} \bar{\mathbf{V}}^{NO} \bullet \bar{\mathbf{n}} \\ \bar{\mathbf{V}}^{NO} \bullet \bar{\mathbf{o}} \end{bmatrix}$$

# Rotation (around the Z-Axis)

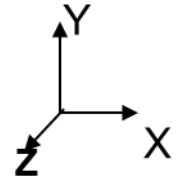
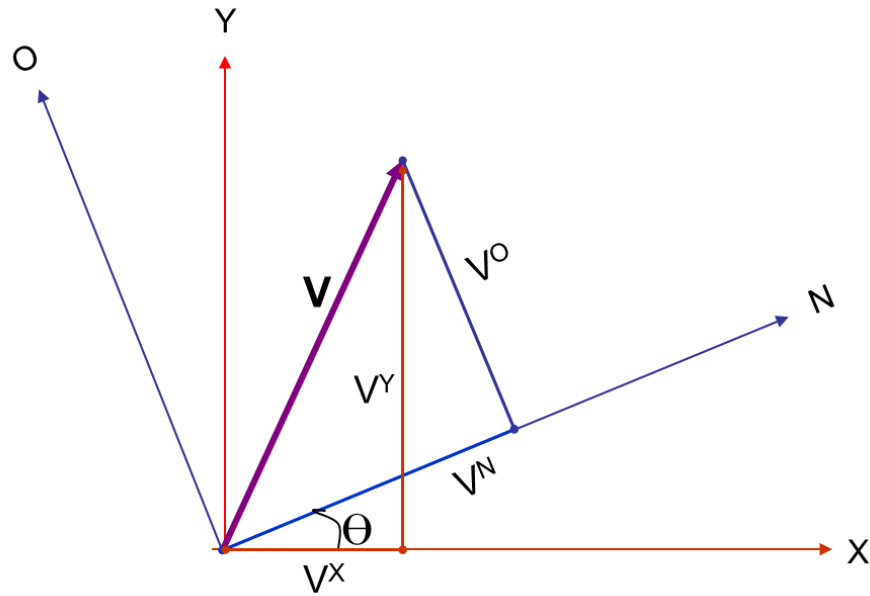

$\theta$  = Angle of rotation between the  $XY$  and  $NO$  coordinate axis

$$\bar{\mathbf{V}}^{XY} = \begin{bmatrix} V^X \\ V^Y \end{bmatrix} \quad \bar{\mathbf{V}}^{NO} = \begin{bmatrix} V^N \\ V^O \end{bmatrix}$$

# Unit vector along X-Axis

Can be considered with respect to the XY coordinates or NO coordinates

$$\|\bar{V}^{XY}\| = \|\bar{V}^{NO}\|$$

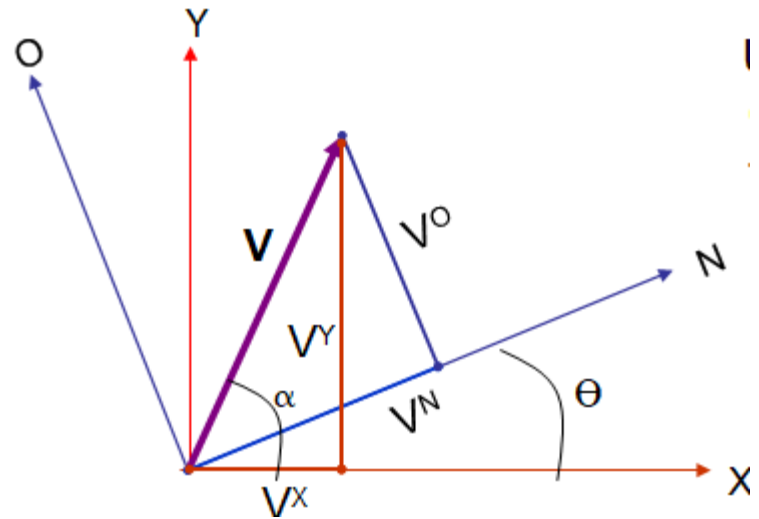

$$V^X = \|\bar{V}^{XY}\| \cos \alpha = \|\bar{V}^{NO}\| \cos \alpha = \bar{V}^{NO} \cdot \bar{x}$$

$$V^X = (V^N * \bar{n} + V^O * \bar{o}) \cdot \bar{x}$$

# Unit vector along X-Axis

$$\begin{aligned}
 V^X &= V^N (\bar{x} \cdot \bar{n}) + V^O (\bar{x} \cdot \bar{o}) \\
 &= V^N (\cos \theta) + V^O (\cos(\theta + 90)) \\
 &= V^N (\cos \theta) - V^O (\sin \theta)
 \end{aligned}$$

Similarly....

$$V^Y = \|\bar{V}^{NO}\| \sin \alpha = \|\bar{V}^{NO}\| \cos(90 - \alpha) = \bar{V}^{NO} \cdot \bar{y}$$

$$V^Y = (V^N * \bar{n} + V^O * \bar{o}) \cdot \bar{y}$$

$$\begin{aligned}
 V^Y &= V^N (\bar{y} \cdot \bar{n}) + V^O (\bar{y} \cdot \bar{o}) \\
 &= V^N (\cos(90 - \theta)) + V^O (\cos \theta) \\
 &= V^N (\sin \theta) + V^O (\cos \theta)
 \end{aligned}$$

# Unit vector along X-Axis

So...

$$V^X = V^N (\cos \theta) - V^O (\sin \theta)$$

$$V^Y = V^N (\sin \theta) + V^O (\cos \theta)$$

$$\bar{V}^{XY} = \begin{bmatrix} V^X \\ V^Y \end{bmatrix}$$

Written in Matrix Form

$$\bar{V}^{XY} = \begin{bmatrix} V^X \\ V^Y \end{bmatrix} = \begin{bmatrix} \cos \theta & -\sin \theta \\ \sin \theta & \cos \theta \end{bmatrix} \begin{bmatrix} V^N \\ V^O \end{bmatrix}$$

# HOMOGENEOUS REPRESENTATION

$$\begin{aligned}
 \mathbf{V}^{XY} &= \begin{bmatrix} \mathbf{V}^X \\ \mathbf{V}^Y \end{bmatrix} = \begin{bmatrix} \mathbf{P}_x \\ \mathbf{P}_y \end{bmatrix} + \begin{bmatrix} \cos \theta & -\sin \theta \\ \sin \theta & \cos \theta \end{bmatrix} \begin{bmatrix} \mathbf{V}^N \\ \mathbf{V}^O \end{bmatrix} \\
 &= \begin{bmatrix} \mathbf{V}^X \\ \mathbf{V}^Y \\ \mathbf{1} \end{bmatrix} = \begin{bmatrix} \mathbf{P}_x \\ \mathbf{P}_y \\ \mathbf{1} \end{bmatrix} + \begin{bmatrix} \cos \theta & -\sin \theta & 0 \\ \sin \theta & \cos \theta & 0 \\ 0 & 0 & 1 \end{bmatrix} \begin{bmatrix} \mathbf{V}^N \\ \mathbf{V}^O \\ \mathbf{1} \end{bmatrix} \\
 &= \begin{bmatrix} \mathbf{V}^X \\ \mathbf{V}^Y \\ \mathbf{1} \end{bmatrix} = \begin{bmatrix} \cos \theta & -\sin \theta & \mathbf{P}_x \\ \sin \theta & \cos \theta & \mathbf{P}_y \\ 0 & 0 & 1 \end{bmatrix} \begin{bmatrix} \mathbf{V}^N \\ \mathbf{V}^O \\ \mathbf{1} \end{bmatrix} \\
 \mathbf{H} &= \begin{bmatrix} \cos \theta & -\sin \theta & \mathbf{P}_x \\ \sin \theta & \cos \theta & \mathbf{P}_y \\ 0 & 0 & 1 \end{bmatrix}
 \end{aligned}$$

# Rotation Matrices in 3D

$$\mathbf{R}_z = \begin{bmatrix} \cos \theta & -\sin \theta & 0 \\ \sin \theta & \cos \theta & 0 \\ 0 & 0 & 1 \end{bmatrix}$$

**Rotation around the Z-Axis**

$$\mathbf{R}_y = \begin{bmatrix} \cos \theta & 0 & \sin \theta \\ 0 & 1 & 0 \\ -\sin \theta & 0 & \cos \theta \end{bmatrix}$$

**Rotation around the Y-Axis**

$$\mathbf{R}_x = \begin{bmatrix} 1 & 0 & 0 \\ 0 & \cos \theta & -\sin \theta \\ 0 & \sin \theta & \cos \theta \end{bmatrix}$$

**Rotation around the X-Axis**

# Homogeneous Matrices in 3D

H is a 4x4 matrix that can describe a translation, rotation, or both in one matrix

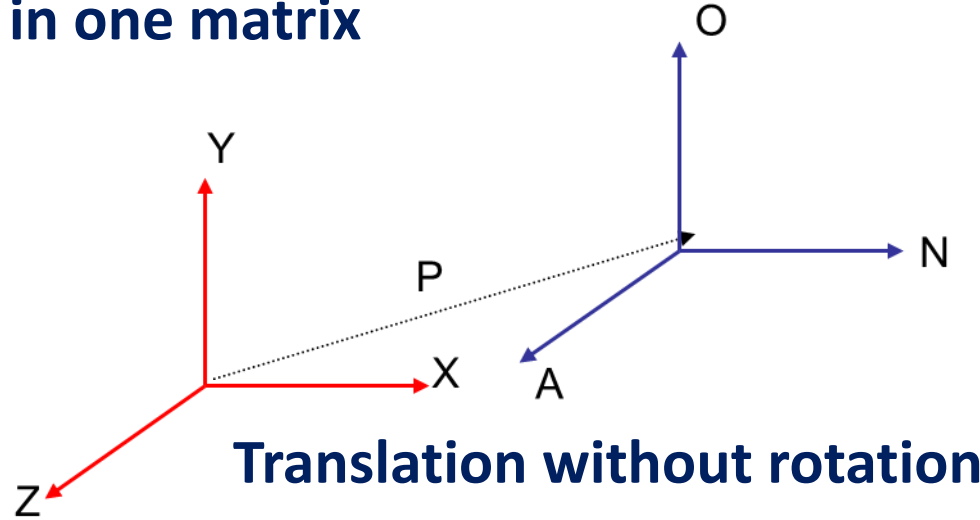

$$H = \begin{bmatrix} 1 & 0 & 0 & P_x \\ 0 & 1 & 0 & P_y \\ 0 & 0 & 1 & P_z \\ 0 & 0 & 0 & 1 \end{bmatrix}$$

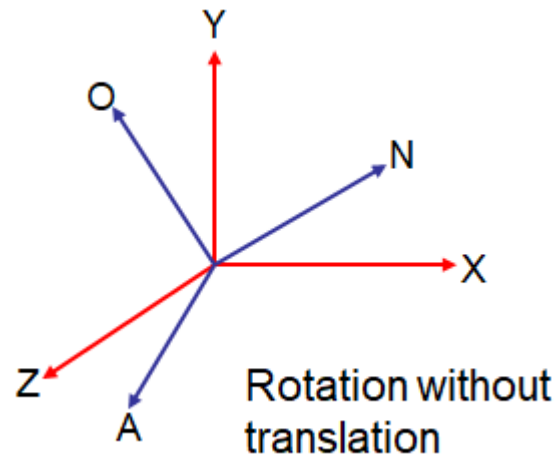

$$H = \begin{bmatrix} n_x & o_x & a_x & 0 \\ n_y & o_y & a_y & 0 \\ n_z & o_z & a_z & 0 \\ 0 & 0 & 0 & 1 \end{bmatrix}$$



# Homogeneous Matrices in 3D

The (n,o,a) position of a point relative to the current coordinate frame you are in.

$$V^{XY} = H \begin{bmatrix} V^N \\ V^O \\ V^A \\ 1 \end{bmatrix}$$

$$V^{XY} = \begin{bmatrix} \mathbf{n}_x & \mathbf{o}_x & \mathbf{a}_x & \mathbf{P}_x \\ \mathbf{n}_y & \mathbf{o}_y & \mathbf{a}_y & \mathbf{P}_y \\ \mathbf{n}_z & \mathbf{o}_z & \mathbf{a}_z & \mathbf{P}_z \\ \mathbf{0} & \mathbf{0} & \mathbf{0} & \mathbf{1} \end{bmatrix} \begin{bmatrix} V^N \\ V^O \\ V^A \\ 1 \end{bmatrix}$$

Translation without rotation

$$V^X = \mathbf{n}_x V^N + \mathbf{o}_x V^O + \mathbf{a}_x V^A + \mathbf{P}_x$$

The rotation and translation part can be combined into a single homogeneous matrix IF and ONLY IF both are relative to the same coordinate frame.

# Denavit - Hartenberg Parameters

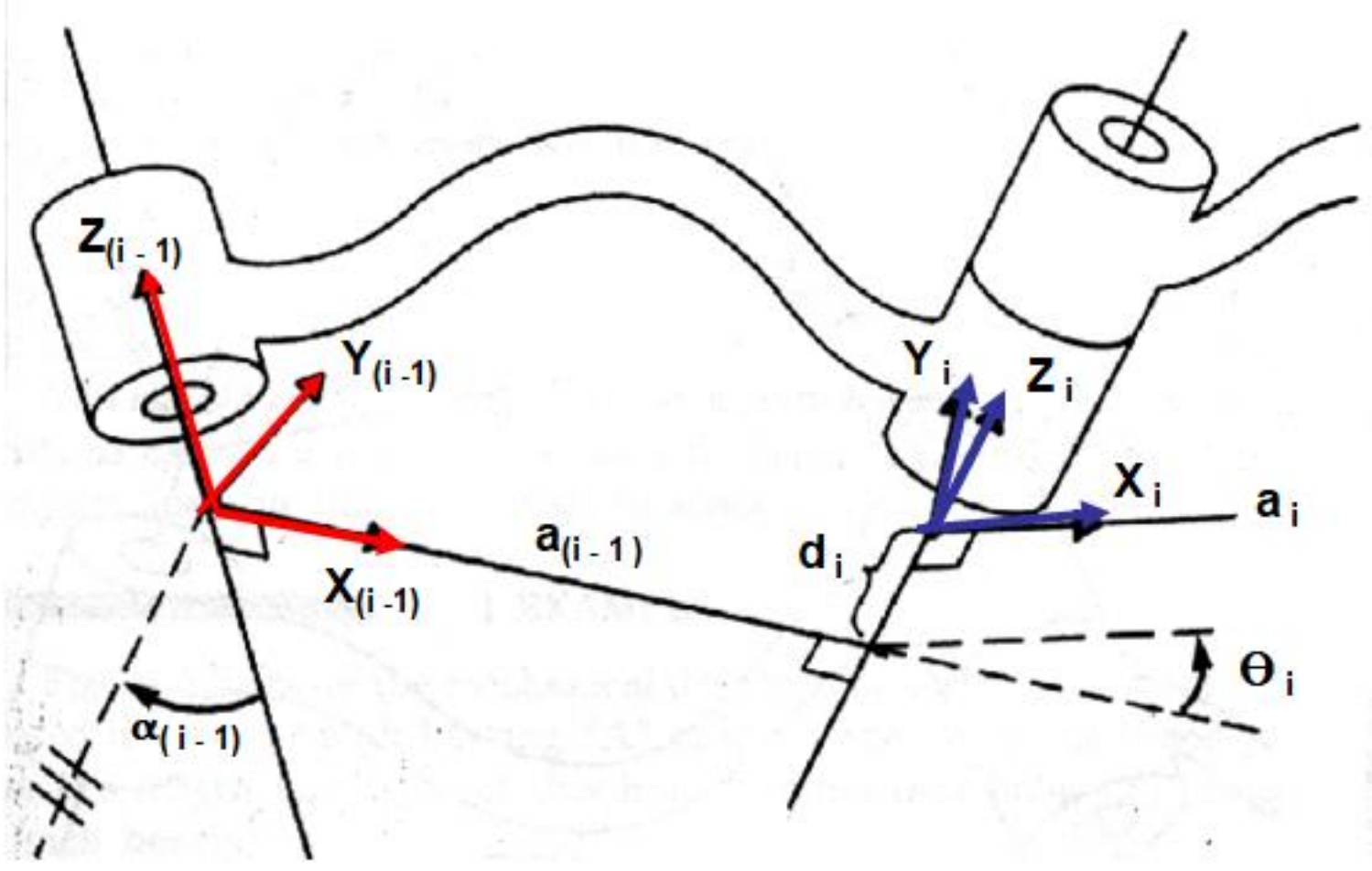

# Denavit - Hartenberg Parameters

Each joint is assigned a coordinate frame. Using the Denavit-Hartenberg notation, you need 4 parameters to describe how a frame (i) relates to a previous frame (i-1).

The Parameters/Variables:  $\alpha$ ,  $a$ ,  $d$ ,  $\Theta$

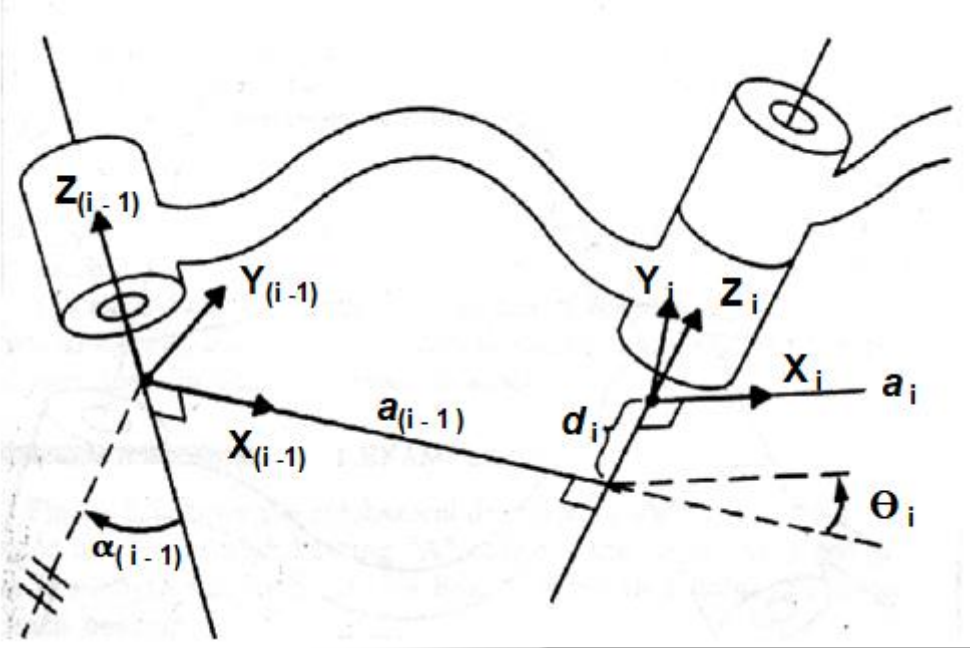

# Denavit - Hartenberg Parameters

## 1) $a(i-1)$

$a(i-1)$  is the length of the perpendicular between the joint axes.

The joint axes is the axes around which revolution takes place which are the  $Z(i-1)$  and  $Z(i)$  axes. These two axes can be viewed as lines in space. The common perpendicular is the shortest line between the two axis-lines and is perpendicular to both axis-lines.

# Denavit - Hartenberg Parameters

**Visual Approach - “A way to visualize the link parameter  $a(i-1)$  is to imagine an expanding cylinder whose axis is the  $Z(i-1)$  axis - when the cylinder just touches the joint axis  $i$  the radius of the cylinder is equal to  $a(i-1)$ .” (Manipulator Kinematics)**

**It’s Usually on the Diagram Approach - If the diagram already specifies the various coordinate frames, then the common perpendicular is usually the  $X(i-1)$  axis. So  $a(i-1)$  is just the displacement along the  $X(i-1)$  to move from the  $(i-1)$  frame to the  $i$  frame.**

**If the link is prismatic, then  $a(i-1)$  is a variable, not a parameter**

# Denavit - Hartenberg Parameters

**Visual Approach - “A way to visualize the link parameter  $a(i-1)$  is to imagine an expanding cylinder whose axis is the  $Z(i-1)$  axis - when the cylinder just touches the joint axis  $i$  the radius of the cylinder is equal to  $a(i-1)$ .” (Manipulator Kinematics)**

**It’s Usually on the Diagram Approach - If the diagram already specifies the various coordinate frames, then the common perpendicular is usually the  $X(i-1)$  axis. So  $a(i-1)$  is just the displacement along the  $X(i-1)$  to move from the  $(i-1)$  frame to the  $i$  frame.**

**If the link is prismatic, then  $a(i-1)$  is a variable, not a parameter**

# Denavit - Hartenberg Parameters

## 2) $\alpha (i-1)$

Amount of rotation around the common perpendicular so that the joint axes are parallel.

## 3) $d(i-1)$

The displacement along the  $Z_i$  axis needed to align the  $a(i-1)$  common perpendicular to the  $a_i$  commonperpendicular.

If the link is prismatic, then  $a(i-1)$  is a variable, not a parameter

# Denavit - Hartenberg Parameters

## 4) $\theta_i$

Amount of rotation around the  $Z_i$  axis needed to align the  $X_{(i-1)}$  axis with the  $X_i$  axis.

$$\begin{bmatrix} \cos\theta_i & -\sin\theta_i & 0 & a_{(i-1)} \\ \sin\theta_i \cos\alpha_{(i-1)} & \cos\theta_i \cos\alpha_{(i-1)} & -\sin\alpha_{(i-1)} & -\sin\alpha_{(i-1)}d_i \\ \sin\theta_i \sin\alpha_{(i-1)} & \cos\theta_i \sin\alpha_{(i-1)} & \cos\alpha_{(i-1)} & \cos\alpha_{(i-1)}d_i \\ 0 & 0 & 0 & 1 \end{bmatrix}$$





# UNIT III

## DIFFERENTIAL KINEMATICS

CLOs	Course Learning Outcome
CLO9	Describe the differential kinematics of planar manipulators.
CLO10	Illustrate Lagrange-Euler formulation.
CLO11	Discuss jacobian and robot dynamics.
CLO12	Illustrate Newton-Euler formulation.

# DIRECT KINEMATICS

➤ **Manipulator**

**series of links connected by means of joints**

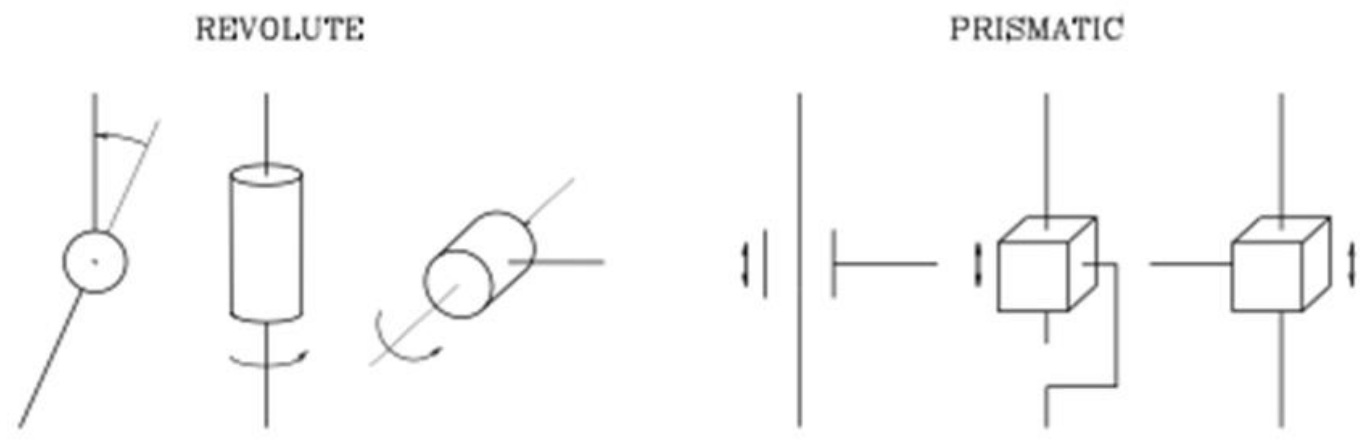

**Kinematic chain (from base to end-effector) open (only one sequence) closed (loop)**

# Degree of freedom

- Degree of freedom
  - Associated with a joint articulation = joint variable
- Base frame and end-effector frame

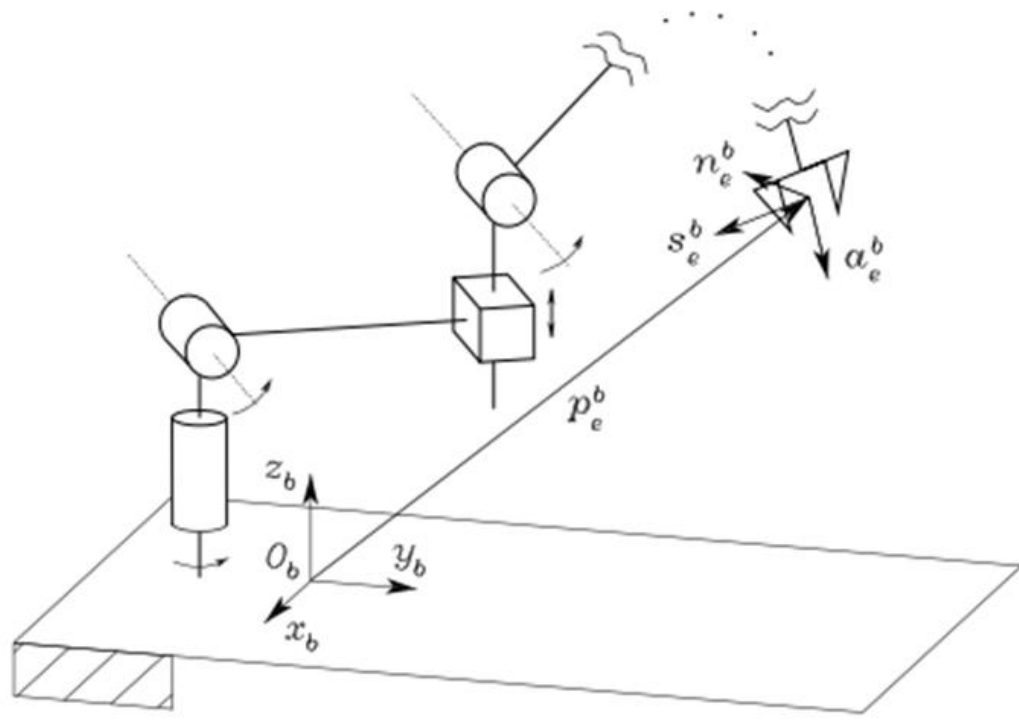

# Direct kinematics equation

$$\mathbf{T}_e^b(\mathbf{q}) = \begin{bmatrix} \mathbf{n}_e^b(\mathbf{q}) & \mathbf{s}_e^b(\mathbf{q}) & \mathbf{a}_e^b(\mathbf{q}) & \mathbf{p}_e^b(\mathbf{q}) \\ 0 & 0 & 0 & 1 \end{bmatrix}$$

# Two-link planar arm

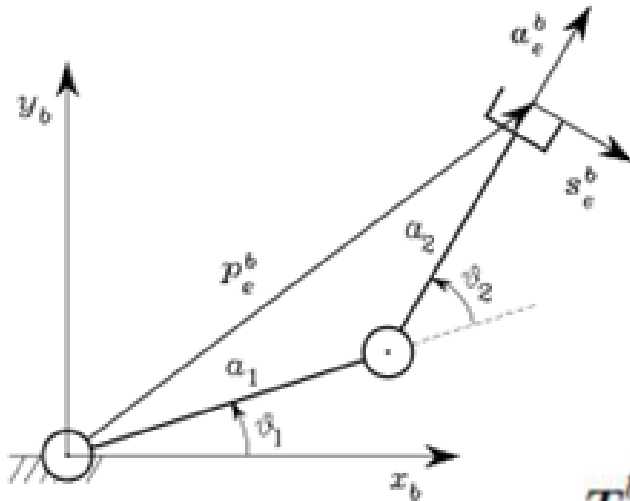

$$T_e^b(q) = \begin{bmatrix} n_e^b & s_e^b & a_e^b & p_e^b \\ 0 & 0 & 0 & 1 \end{bmatrix}$$

$$= \begin{bmatrix} 0 & s_{12} & c_{12} & a_1 c_1 + a_2 c_{12} \\ 0 & -c_{12} & s_{12} & a_1 s_1 + a_2 s_{12} \\ 1 & 0 & 0 & 0 \\ 0 & 0 & 0 & 1 \end{bmatrix}$$

# Denavit-Hartenberg convention

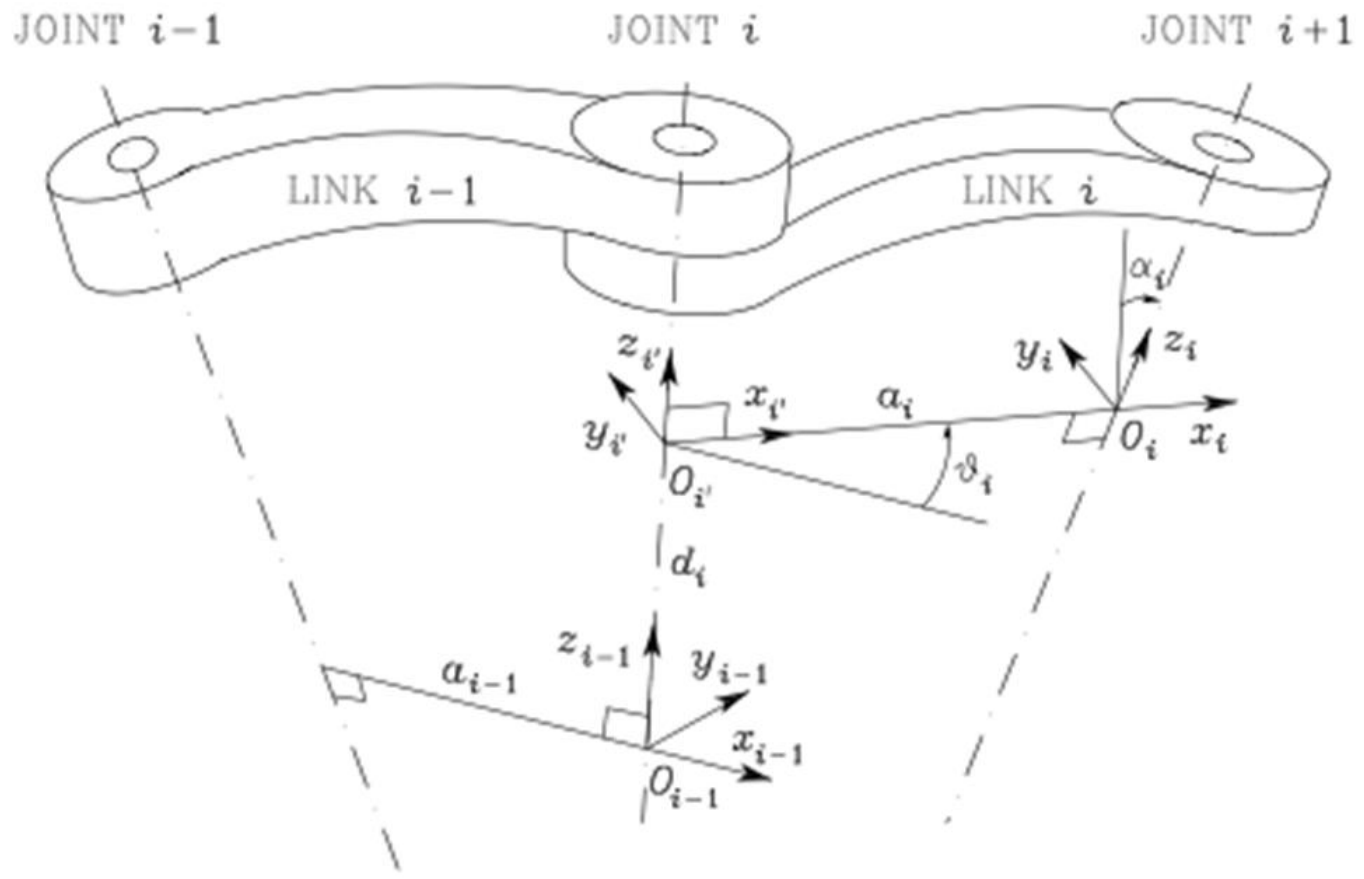

# Denavit–Hartenberg convention

- choose axis  $z_i$  along axis of Joint  $i + 1$
- • locate  $O_i$  at the intersection of axis  $z_i$  with the common normal to axes  $z_{i-1}$  and  $z_i$ , and  $O'_i$  at intersection of common normal with axis  $z_{i-1}$
- • choose axis  $x_i$  along common the normal to axes  $z_{i-1}$  and  $z_i$  with positive direction from Joint  $i$  to Joint  $i + 1$
- • choose axis  $y_i$  so as to complete right-handed frame
- • No nunique definition of link frame:



# Denavit–Hartenberg convention

- For Frame 0, only the direction of axis  $z_0$  is specified: then  $O_0$  and  $X_0$  can be chosen arbitrarily.
- For Frame  $n$ , since there is no Joint  $n + 1$ ,  $z_n$  is not uniquely defined while  $x_n$  has to be normal to axis  $z_{n-1}$ ; typically Joint  $n$  is revolute and thus  $z_n$  can be aligned with  $z_{n-1}$ .
- when two consecutive axes are parallel, the common normal between them is not uniquely defined.
- when two consecutive axes intersect, the positive direction of  $x_i$  is arbitrary.
- When Joint  $i$  is prismatic, only the direction of  $z_{i-1}$  is specified.

# Denavit–Hartenberg parameters

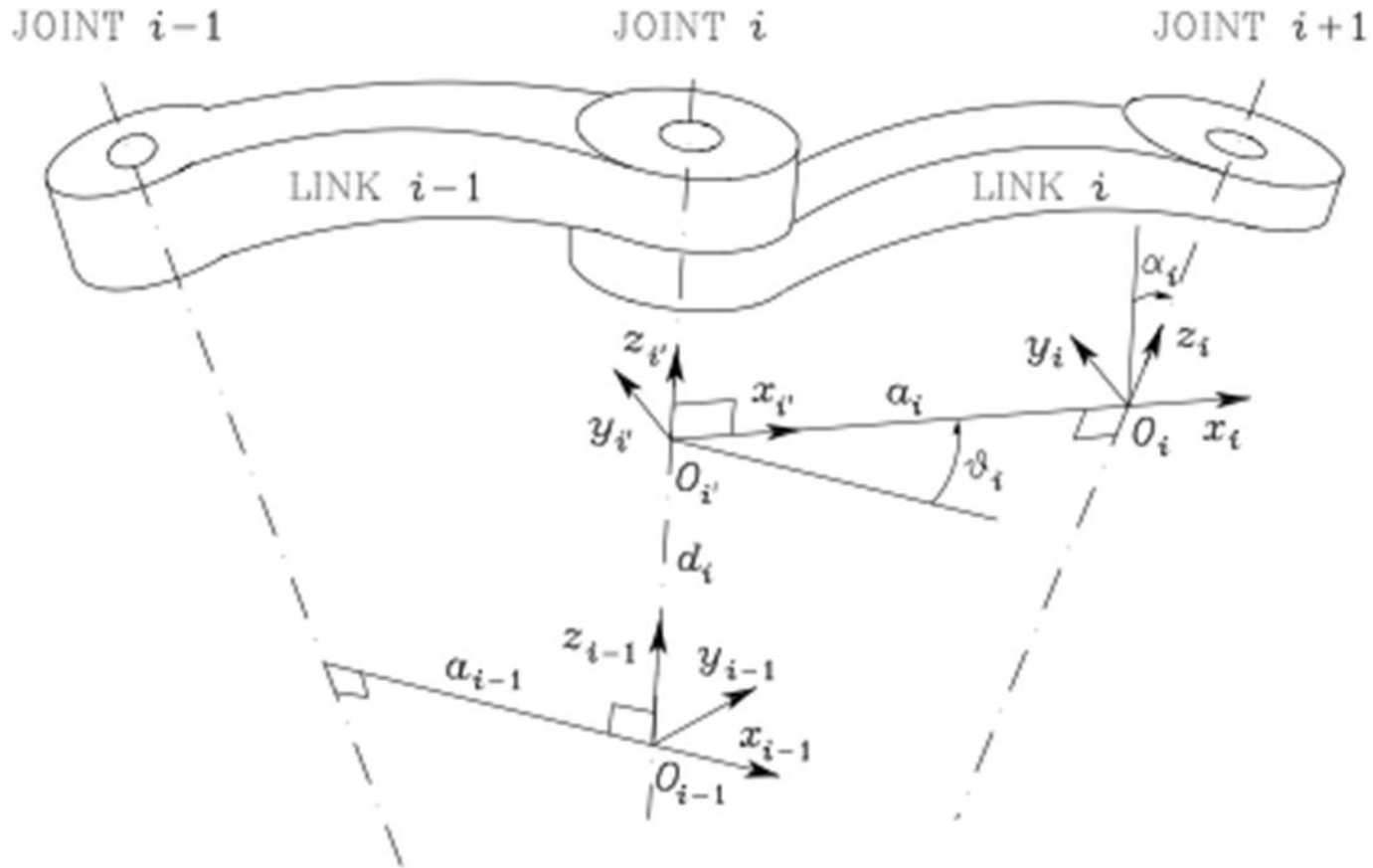

# Denavit–Hartenberg parameters

- $a_i$  distance between  $O_i$  and  $O_i'$ ;
- $d_i$  coordinate of  $O_i'$  and  $z_{i-1}$ ;
- $\alpha_i$  angle between axes  $z_{i-1}$  and  $z_i$  about axis  $x_i$  to be taken positive when rotation is made counter-clockwise
- $u_i$  angle between axes  $x_{i-1}$  and  $x_i$  about axis  $z_{i-1}$  to be taken positive when rotation is made counter-clockwise
- $a_i$  and  $\alpha_i$  are always constant
- if Joint  $i$  is revolute the variable is  $u_i$
- if Joint  $i$  is prismatic the variable is  $d_i$

# Coordinate transformation

$$A_{i'}^{i-1} = \begin{bmatrix} c\theta_i & -s\theta_i & 0 & 0 \\ s\theta_i & c\theta_i & 0 & 0 \\ 0 & 0 & 1 & d_i \\ 0 & 0 & 0 & 1 \end{bmatrix}$$

$$A_i^{i'} = \begin{bmatrix} 1 & 0 & 0 & a_i \\ 0 & c\alpha_i & -s\alpha_i & 0 \\ 0 & s\alpha_i & c\alpha_i & 0 \end{bmatrix}$$

$$A_i^{i-1}(q_i) = A_{i'}^{i-1} A_i^{i'} = \begin{bmatrix} c\theta_i & -s\theta_i c\alpha_i & s\theta_i s\alpha_i & a_i c\theta_i \\ s\theta_i & c\theta_i c\alpha_i & -c\theta_i s\alpha_i & a_i s\theta_i \\ 0 & s\alpha_i & c\alpha_i & d_i \\ 0 & 0 & 0 & 1 \end{bmatrix}$$

# Procedure

- Find and number consecutively the joint axes; set the directions of axes  $z_0, \dots, z_{n-1}$ .
- Choose Frame 0 by locating the origin on axis  $z_0$ ; axes  $x_0$  and  $y_0$  are chosen so as to obtain a righthanded frame. If feasible, it is worth choosing Frame 0 to coincide with the base frame.
- Execute steps from 3 to 5 for  $i = 1, \dots, n - 1$ : Find and number consecutively the joint axes; set the directions of axes  $z_0, \dots, z_{n-1}$ .
-

# Procedure

- Choose Frame 0 by locating the origin on axis  $z_0$ ; axes  $x_0$  and  $y_0$  are chosen so as to obtain a righthanded frame. If feasible, it is worth choosing Frame 0 to coincide with the base frame.
- Execute steps from 3 to 5 for  $i = 1, \dots, n - 1$ :
- Locate the origin  $O_i$  at the intersection of  $z_i$  with the common normal to axes  $z_{i-1}$  and  $z_i$ . If axes  $z_{i-1}$  and  $z_i$  are parallel and Joint  $i$  is revolute, then locate  $O_i$  so that  $d_i=0$ ; if Joint  $i$  is prismatic, locate  $O_i$  at a reference position for the joint range, e.g., a mechanical limit.

# Procedure

- Choose axis  $x_i$  along the common normal to axes  $z_{i-1}$  and  $z_i$  with direction from Joint  $i$  to Joint  $i + 1$ .
- Choose axis  $y_i$  so as to obtain a right-handed frame to complete.
- Choose Frame  $n$ ; if Joint  $n$  is revolute, then align  $z_n$  with  $z_{n-1}$ , otherwise, if Joint  $n$  is prismatic, then choose  $z_n$  arbitrarily. Axis  $x_n$  is set according to step 4.
- For  $i = 1, \dots, n$ , form the table of parameters  $a_i, d_i, \alpha_i, u_i$ .
- On the basis of the parameters in 7, compute the homogeneous transformation matrices  $A_{i-1}^{(q_i)}$  for  $i=1, \dots, n$ .

# Three-link planar arm

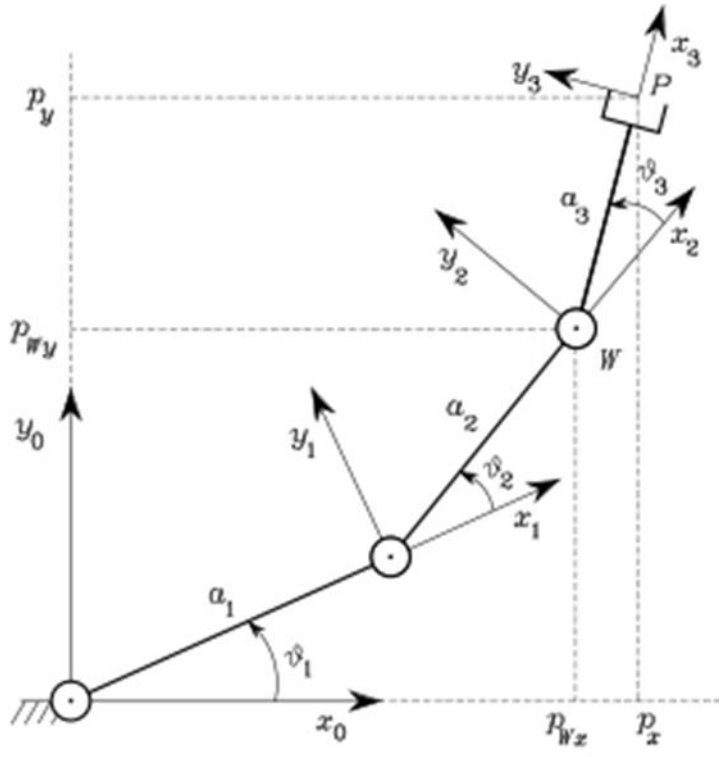
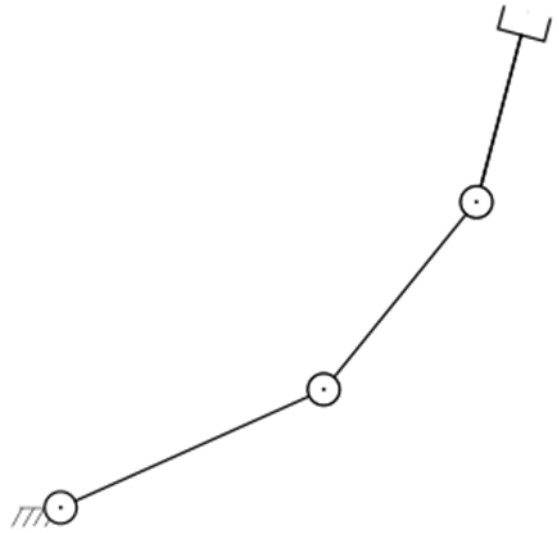



# Three-link planar arm

Link	$a_i$	$\alpha_i$	$d_i$	$\vartheta_i$
1	$a_1$	0	0	$\vartheta_1$
2	$a_2$	0	0	$\vartheta_2$
3	$a_3$	0	0	$\vartheta_3$

$$A_i^{i-1} = \begin{bmatrix} c_i & -s_i & 0 & a_i c_i \\ s_i & c_i & 0 & a_i s_i \\ 0 & 0 & 1 & 0 \\ 0 & 0 & 0 & 1 \end{bmatrix} \quad i = 1, 2, 3$$

# Three-link planar arm

$$T_3^0 = A_1^0 A_2^1 A_3^2$$

$$= \begin{bmatrix} c_{123} & -s_{123} & 0 & a_1 c_1 + a_2 c_{12} + a_3 c_{123} \\ s_{123} & c_{123} & 0 & a_1 s_1 + a_2 s_{12} + a_3 s_{123} \\ 0 & 0 & 1 & 0 \\ 0 & 0 & 0 & 1 \end{bmatrix}$$

# Spherical arm

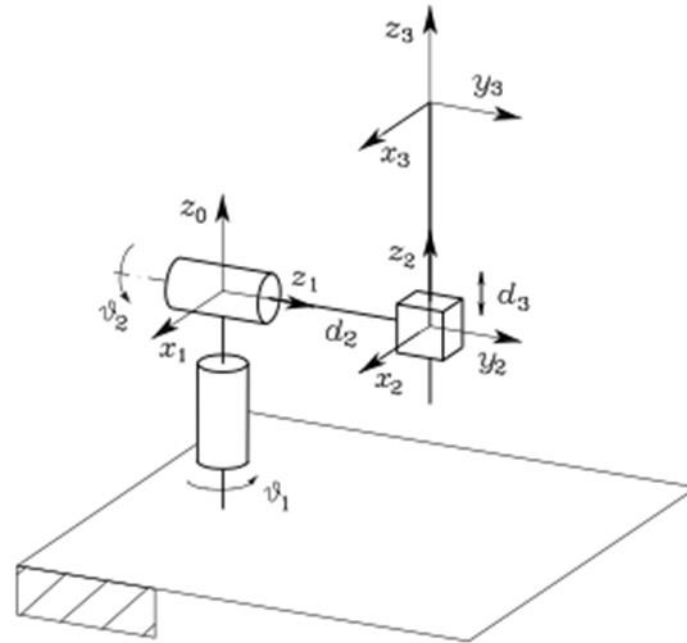
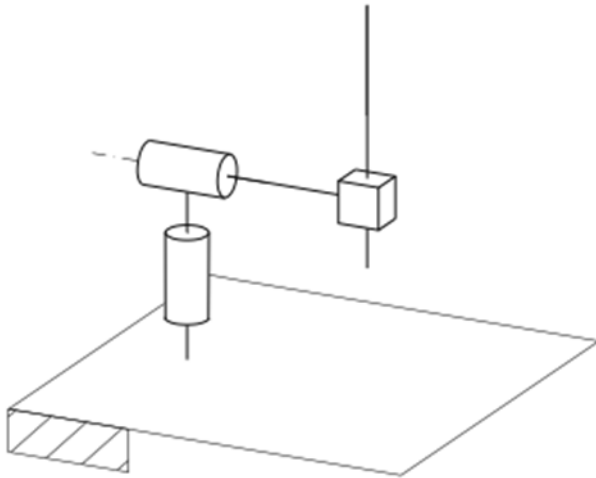

Link	$a_i$	$\alpha_i$	$d_i$	$\vartheta_i$
1	0	$-\pi/2$	0	$\vartheta_1$
2	0	$\pi/2$	$d_2$	$\vartheta_2$
3	0	0	$d_3$	0

# Spherical arm

$$A_1^0 = \begin{bmatrix} c_1 & 0 & -s_1 & 0 \\ s_1 & 0 & c_1 & 0 \\ 0 & -1 & 0 & 0 \\ 0 & 0 & 0 & 1 \end{bmatrix} \quad A_2^1 = \begin{bmatrix} c_2 & 0 & s_2 & 0 \\ s_2 & 0 & -c_2 & 0 \\ 0 & 1 & 0 & d_2 \\ 0 & 0 & 0 & 1 \end{bmatrix}$$

$$A_3^2 = \begin{bmatrix} 1 & 0 & 0 & 0 \\ 0 & 1 & 0 & 0 \\ 0 & 0 & 1 & d_3 \\ 0 & 0 & 0 & 1 \end{bmatrix}$$

$$T_3^0 = A_1^0 A_2^1 A_3^2$$

$$= \begin{bmatrix} c_1 c_2 & -s_1 & c_1 s_2 & c_1 s_2 d_3 - s_1 d_2 \\ s_1 c_2 & c_1 & s_1 s_2 & s_1 s_2 d_3 + c_1 d_2 \\ -s_2 & 0 & c_2 & c_2 d_3 \\ 0 & 0 & 0 & 1 \end{bmatrix}$$

# Anthropomorphic arm

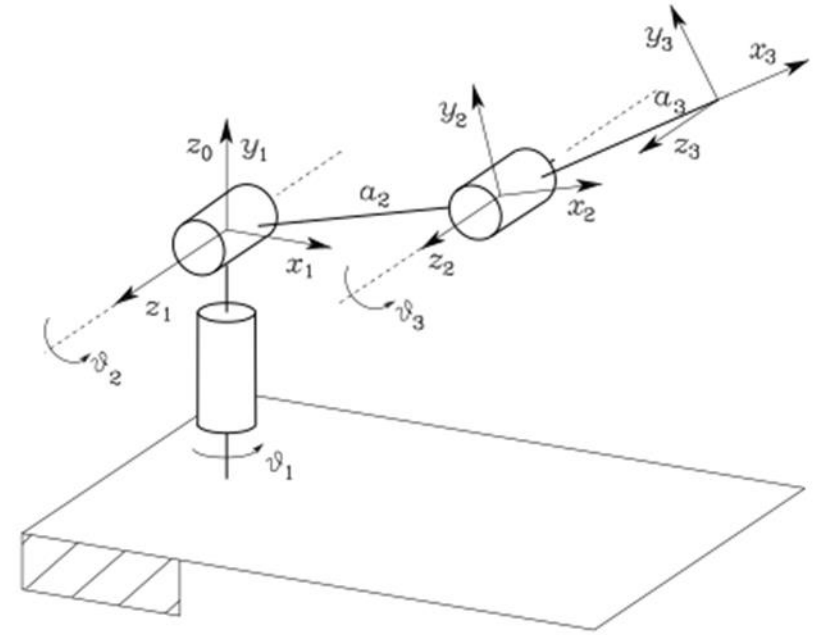
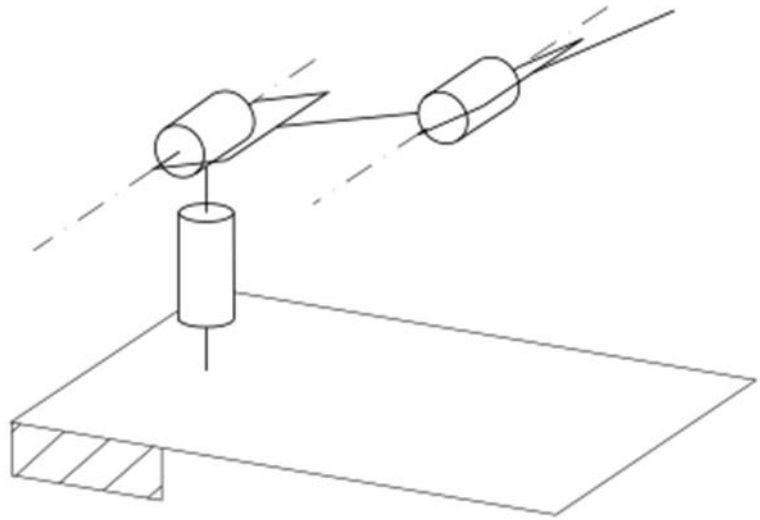

# Anthropomorphic arm

Link	$a_i$	$\alpha_i$	$d_i$	$\vartheta_i$
1	0	$\pi/2$	0	$\vartheta_1$
2	$a_2$	0	0	$\vartheta_2$
3	$a_3$	0	0	$\vartheta_3$

$$A_1^0 = \begin{bmatrix} c_1 & 0 & s_1 & 0 \\ s_1 & 0 & -c_1 & 0 \\ 0 & 1 & 0 & 0 \\ 0 & 0 & 0 & 1 \end{bmatrix}$$

$$A_i^{i-1} = \begin{bmatrix} c_i & -s_i & 0 & a_i c_i \\ s_i & c_i & 0 & a_i s_i \\ 0 & 0 & 1 & 0 \\ 0 & 0 & 0 & 1 \end{bmatrix}$$

$$i = 2, 3$$

# Anthropomorphic arm

$$\begin{aligned} T_3^0 &= A_1^0 A_2^1 A_3^2 \\ &= \begin{bmatrix} c_1 c_{23} & -c_1 s_{23} & s_1 & c_1(a_2 c_2 + a_3 c_{23}) \\ s_1 c_{23} & -s_1 s_{23} & -c_1 & s_1(a_2 c_2 + a_3 c_{23}) \\ s_{23} & c_{23} & 0 & a_2 s_2 + a_3 s_{23} \\ 0 & 0 & 0 & 1 \end{bmatrix} \end{aligned}$$

# Spherical wrist

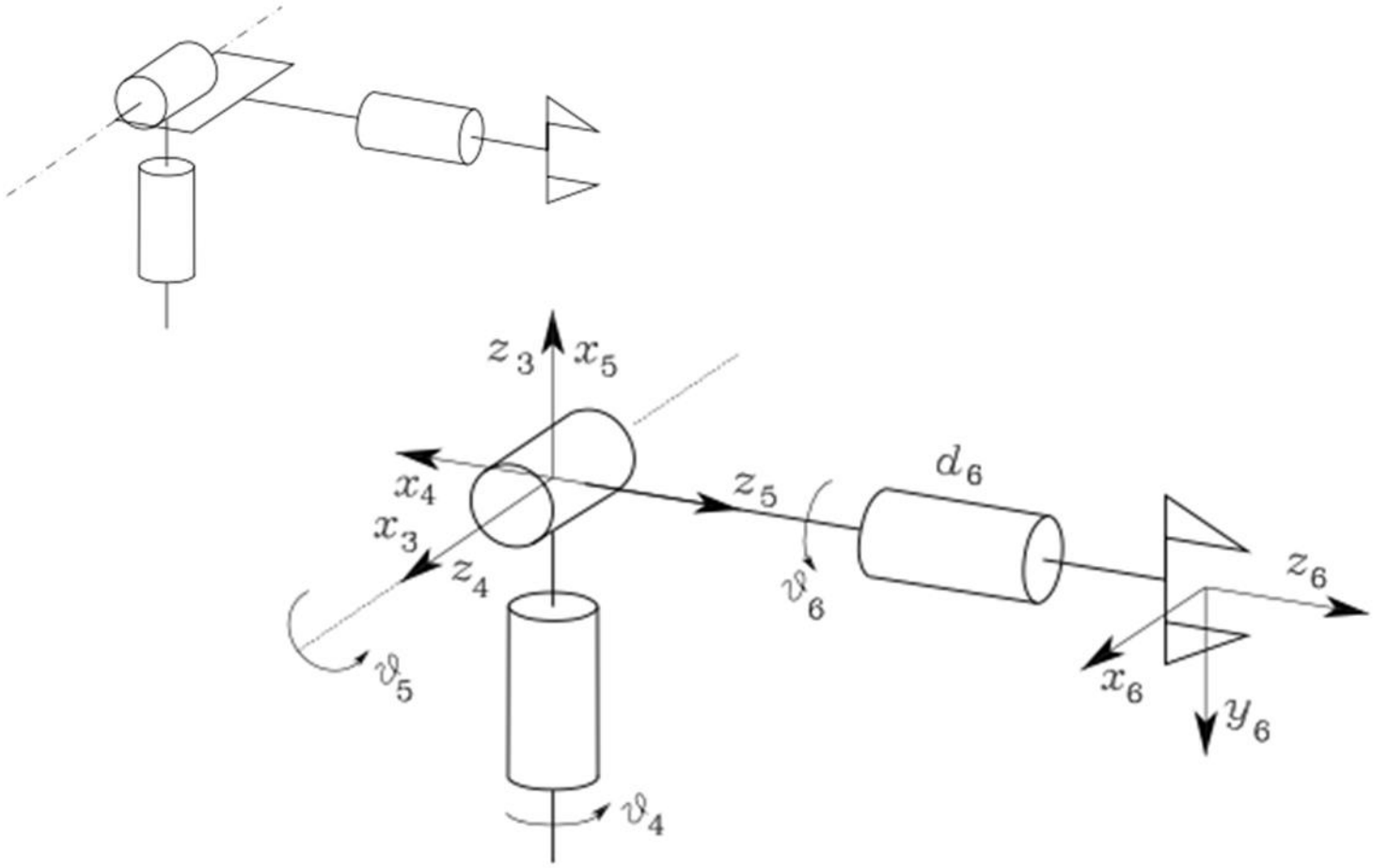



# Spherical wrist

Link	$a_i$	$\alpha_i$	$d_i$	$\vartheta_i$
4	0	$-\pi/2$	0	$\vartheta_4$
5	0	$\pi/2$	0	$\vartheta_5$
6	0	0	$d_6$	$\vartheta_6$

$$A_4^3 = \begin{bmatrix} c_4 & 0 & -s_4 & 0 \\ s_4 & 0 & c_4 & 0 \\ 0 & -1 & 0 & 0 \\ 0 & 0 & 0 & 1 \end{bmatrix} \quad A_5^4 = \begin{bmatrix} c_5 & 0 & s_5 & 0 \\ s_5 & 0 & -c_5 & 0 \\ 0 & 1 & 0 & 0 \\ 0 & 0 & 0 & 1 \end{bmatrix}$$

$$A_6^5 = \begin{bmatrix} c_6 & -s_6 & 0 & 0 \\ s_6 & c_6 & 0 & 0 \\ 0 & 0 & 1 & d_6 \\ 0 & 0 & 0 & 1 \end{bmatrix}$$

# Spherical wrist

$$\begin{aligned}
 T_6^3 &= A_4^3 A_5^4 A_6^5 \\
 &= \begin{bmatrix} c_4 c_5 c_6 - s_4 s_6 & -c_4 c_5 s_6 - s_4 c_6 & c_4 s_5 & c_4 s_5 d_6 \\ s_4 c_5 c_6 + c_4 s_6 & -s_4 c_5 s_6 + c_4 c_6 & s_4 s_5 & s_4 s_5 d_6 \\ -s_5 c_6 & s_5 s_6 & c_5 & c_5 d_6 \\ 0 & 0 & 0 & 1 \end{bmatrix}
 \end{aligned}$$



# UNIT IV

## TRAJECTORY PLANNING

CLOs	Course Learning Outcome
CLO13	Describe Joint space scheme.
CLO14	Illustrate cubic polynomial fit.
CLO15	Classify types of motion.
CLO16	Explain actuators and classify them.

# TRAJECTORY PLANNING

- **Path and trajectory planning means the way that a robot is moved from one location to another in a controlled manner.**
- **The sequence of movements for a controlled movement between motion segment, in straight-line motion or in sequential motions.**
- **It requires the use of both kinematics and dynamics of robots.**

**Path:** A sequence of robot configurations in a particular order without regard to the timing of these configurations.

**Trajectory:** It concerned about when each part of the path must be attained, thus specifying timing.

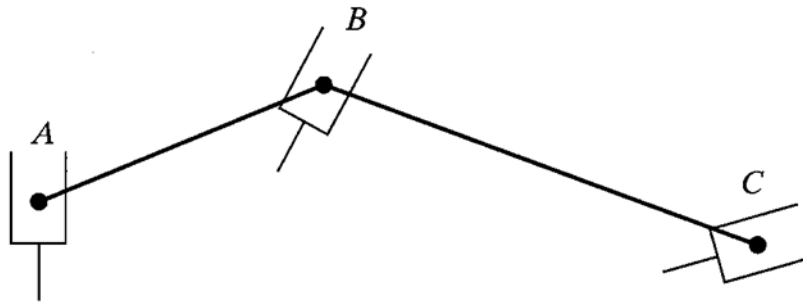

**Fig. Sequential robot movements in a path.**

➤ **Joint-space description:**

The description of the motion to be made by the robot by its joint values.

The motion between the two points is unpredictable.

➤ **Cartesian space description:**

The motion between the two points is known at all times and controllable.

➤ It is easy to visualize the trajectory, but it is difficult to ensure that singularity.

- **Let's consider a simple 2 degree of freedom robot.**
- **We desire to move the robot from Point A to Point B.**
- **Let's assume that both joints of the robot can move at the maximum rate of 10 degree/sec.**
- **Let's assume that both joints of the robot can move at the maximum rate of 10 degree/sec.**



# BASICS OF TRAJECTORY PLANNING

- Move the robot from A to B, to run both joints at their maximum angular velocities.
- After 2 [sec], the lower link will have finished its motion, while the upper link continues for another 3 [sec].
- The path is irregular and the distances traveled by the robot's end are not uniform.

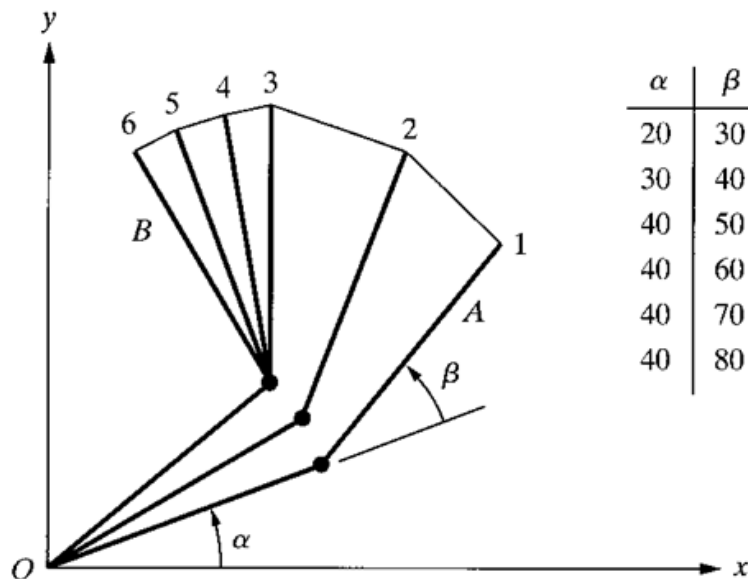

$\alpha$	$\beta$
20	30
30	40
40	50
40	60
40	70
40	80

Fig. Joint-space nonnormalized movements of a robot with two degrees of freedom

# BASICS OF TRAJECTORY PLANNING

- Let's assume that the motions of both joints are normalized by a common factor such that the joint with smaller motion will move proportionally slower and the both joints will start and stop their motion simultaneously.
- Both joints move at different speeds, but move continuously together. The resulting trajectory will be different.

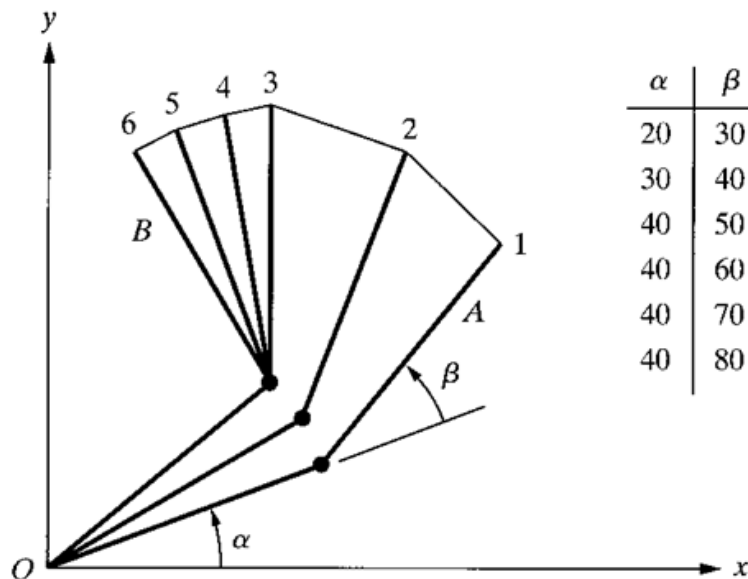

$\alpha$	$\beta$
20	30
30	40
40	50
40	60
40	70
40	80

Fig. Joint-space nonnormalized movements of a robot with two degrees of freedom

# BASICS OF TRAJECTORY PLANNING

- Let's assume that the robot's hand follow a known path between point A to B with straight line.
- The simplest solution would be to draw a line between points A and B, so called interpolation.

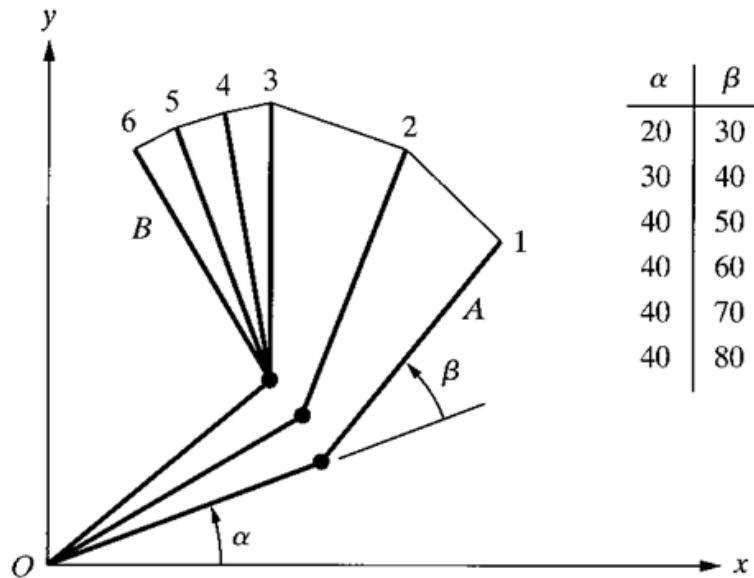

- Divide the line into five segments and solve for necessary angles  $\alpha$  and  $\beta$  at each point.
- The joint angles are not uniformly changing.

Fig. Joint-space nonnormalized movements of a robot with two degrees of freedom

# JOINT-SPACE TRAJECTORY PLANNING

- **Third-Order Polynomial Trajectory Planning.**
- **Polynomials of different orders.**
- **Linear functions with parabolic blends.**
- **The initial location and orientation of the robot is known, and using the inverse kinematic equations, we find the final joint angles for the desired position and orientation.**

$$\theta(t) = c_0 + c_1t + c_2t^2 + c_3t^3$$

$$\theta(t_i) = \theta_i$$

$$\theta(t_f) = \theta_f$$

$$\dot{\theta}(t_i) = 0$$

$$\dot{\theta}(t_f) = 0$$

• **Initial Condition**

$$\dot{\theta}(t) = c_1 + 2c_2t + 3c_3t^2$$

• **First derivative of the polynomial of equation**

$$\theta(t_i) = c_0 = \theta_i$$

$$\theta(t_f) = c_0 + c_1t_f + c_2t_f^2 + c_3t_f^3$$

$$\dot{\theta}(t_i) = c_1 = 0$$

$$\dot{\theta}(t_f) = c_1 + 2c_2t_f + 3c_3t_f^2 = 0$$

• **Substituting the initial and final conditions**

# JOINT-SPACE TRAJECTORY PLANNING

- It is desired to have the first joint of a six-axis robot go from initial angle of  $30^\circ$  to a final angle of  $75^\circ$  in 5 seconds. Using a third-order polynomial, calculate the joint angle at 1, 2, 3, and 4 seconds.

$$\theta(t) = c_0 + c_1t + c_2t^2 + c_3t^3$$

$$\theta(0) = c_0 = 30$$

$$\dot{\theta}(0) = c_1 = 0$$

# JOINT-SPACE TRAJECTORY PLANNING

- **Fifth-Order Polynomial Trajectory Planning.**
- **Specify the initial and ending accelerations for a segment.**
- **To use a fifth-order polynomial for planning a trajectory, the total**
- **Calculation of the coefficients of a fifth-order polynomial with position, velocity and a acceleration boundary conditions can be possible with below equations.**

$$\theta(t) = c_0 + c_1t + c_2t^2 + c_3t^3 + c_4t^4 + c_5t^5$$

$$\dot{\theta}(t) = c_1 + 2c_2t + 3c_3t^2$$

$$\ddot{\theta}(t) = 2c_2 + 6c_3t + 12c_4t^2 + 20c_5t^3$$

# JOINT-SPACE TRAJECTORY PLANNING

- Linear Segments with Parabolic Blends
- Linear segment can be blended with parabolic sections at the beginning and the end of the motion segment, creating continuous position and velocity.
- Acceleration is constant for the parabolic sections, yielding a continuous velocity at the common points A and B.

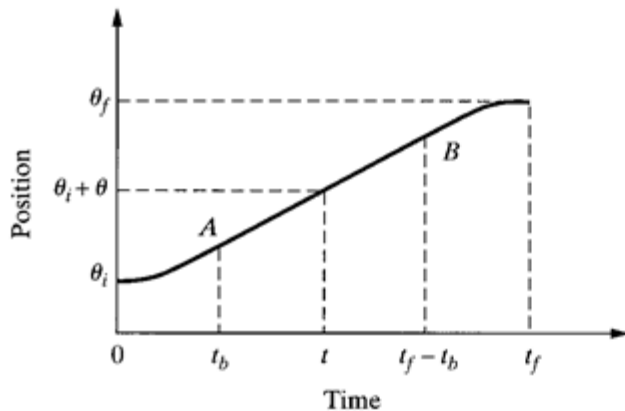

$$\begin{aligned}
 \theta(t) &= c_0 + c_1 t + \frac{1}{2} c_2 t^2 \\
 \dot{\theta}(t) &= c_1 + c_2 t \\
 \ddot{\theta}(t) &= c_2
 \end{aligned}
 \quad \Rightarrow \quad
 \begin{aligned}
 \theta(t) &= \theta_i + \frac{1}{2} c_2 t^2 \\
 \dot{\theta}(t) &= c_2 t \\
 \ddot{\theta}(t) &= c_2
 \end{aligned}$$

Fig. Scheme for linear segments with parabolic blends.

# JOINT-SPACE TRAJECTORY PLANNING

- **Linear Segments with Parabolic Blends and Via Points**
- **The position of the robot at time  $t_0$  is known and using the inverse kinematic equations of the robot, the joint angles at via points and at the end of the motion can be found.**
- **Acceleration is constant for the parabolic sections, yielding a continuous velocity at the common points A and B.**
- **To blend the motion segments together, the boundary conditions of each point to calculate the coefficients of the parabolic segments is used.**
- **Maximum allowable accelerations should not be exceeded.**



# JOINT-SPACE TRAJECTORY PLANNING

- Higher Order Trajectories.
- Incorporating the initial and final boundary conditions together with this information enables us to use higher order polynomials in the below form, so that the trajectory will pass through all specified points.

$$\theta(t) = c_0 + c_1t + c_2t^2 + c_3t^3 + \dots + c_{n-1}t^{n-1} + c_nt^n$$

- It requires extensive calculation for each joint and higher order polynomials.
- Combinations of lower order polynomials for different segments of the trajectory and blending together to satisfy all required boundary conditions is required.

- Cartesian-space trajectories relate to the motions of a robot relative to the Cartesian reference frame.
- In Cartesian-space, the joint values must be repeatedly calculated through the inverse kinematic equations of the robot.
- **Computer Loop Algorithm**
  1. Calculate the position and orientation of the hand based on the selected function for the trajectory.
  2. Calculate the joint values for the position and orientation through the inverse kinematic equations of the robot.
  3. Send the joint information to the controller.
  4. Go to the beginning of the loop.



# UNIT V

## ROBOTIC APPLICATIONS

CLOs	Course Learning Outcome
CLO17	Illustrate various robot applications in manufacturing.
CLO18	Discuss the role of robots in material handling.
CLO19	Explain work cell design.
CLO20	Discuss the role of robots in assembly and inspection.

# APPLICATION OF ROBOT'S

- **Robot applications can be studied under present and future applications.**
- **Under present applications they can be classified into three major headings. They are**
  - 1. Material Transfer, Machine Loading and Unloading.**
  - 2. Processing operations.**
  - 3. Assembly and inspection.**

# APPLICATION OF ROBOT'S

- **In future applications category the list is exhaustive and ever increasing like**
  - 1. Medical**
  - 2. Military (Artillery, Loading, Surveillance)**
  - 3. Home applications.**
  - 4. Electronic industry.**
  - 5. Fully automated machine shop etc.,**

# MATERIAL HANDLING APPLICATIONS:

- **The material handling applications can be divided into two specific categories**
  - 1. Material transfer applications.**
  - 2. Machine loading/ unloading applications**

# General considerations in robot material handling:

- **If a robot has to transfer parts or load a machine, then the following points are to be considered.**
  - 1. Part Positioning and Orientation**
  - 2. Gripper design**
  - 3. Minimum distances moved**
  - 4. Robot work volume**
  - 5. Robot weight capacity**
  - 6. Accuracy and repeatability**
  - 7. Robot configuration**
  - 8. Machine Utilization Problems**



# MATERIAL TRANSFER APPLICATIONS

- **Pick and place operations.**
- **Palletizing and related operations**
- **Machine loading and unloading.**

**In these applications the robot is used to serve a production machine by transferring parts to and/or from the machine.**

# MATERIAL TRANSFER APPLICATIONS

## ➤ MACHINE LOADING:

The robot loads the raw material into the machine but the part/material is ejected by some other means.

## ➤ MACHINE UNLOADING:

In this case the loading of raw material into the machine is done automatically but after completing the process the finished component is removed by robot.

# MATERIAL TRANSFER APPLICATIONS

**Robots are being successfully used to in the loading and unloading function in the following production operations.**

**They are**

- 1. Die casting.**
- 2. Plastic molding.**
- 3. Forging and related operations.**
- 4. Machining operations.**
- 5. Stamping press operations.**

# MATERIAL TRANSFER APPLICATIONS

**Processing Operations:** The processing operations that are performed by a robot can be categorized into the following four types. They are

- 1. Spot welding.**
- 2. Continuous arc welding.**
- 3. Spray coating.**
- 4. Other processing operations.**



*Thank you*