



INSTITUTE OF AERONAUTICAL ENGINEERING (Autonomous)

Dundigal, Hyderabad -500 043

ELECTRICAL AND ELECTRONICS ENGINEERING

COURSE LECTURE NOTES

Course Name	WAVES AND OPTICS
Course Code	AHSB04
Programme	B.Tech
Semester	II
Course Coordinator	Dr. Rizwana, Professor
Course Faculty	Dr. B Manikya Pratima, Associate Professor Ms. Singavarapu Sujani, Assistant Professor
Lecture Numbers	3-96
Topic Covered	All

COURSE OBJECTIVES (COs):

The course should enable the students to:	
I	Enrich knowledge in principles of quantum mechanics and semiconductors.
II	Correlate principles and applications of lasers and fiber optics.
III	Meliorate the knowledge of light and optics and also their applications.
IV	Develop strong fundamentals of transverse, longitudinal waves and harmonic waves.

COURSE LEARNING OUTCOMES (CLOs):

Students, who complete the course, will have demonstrated the ability to do the following:

S. No	Description
AHSB04.01	Recall the basic principles of physics and apply these concepts of physics in solving the real-time problems.
AHSB04.02	Acquire knowledge about fundamental in quantum mechanics
AHSB04.03	Interpretation of dual nature of matter wave concept using Davisson & Germer's experiment
AHSB04.04	Estimate the energy of the particles using Schrödinger's wave equation and apply it to particle in potential box.
AHSB04.05	Recollect the conductivity mechanism involved in semiconductors and calculate carrier concentrations.

S. No	Description
AHSB04.06	Understand the band structure of a solid and classify materials as metals, insulators, or semiconductors, and sketch a schematic band diagram for each one
AHSB04.07	Understand the basic principles involved in the production of Laser light and also real time applications of lasers.
AHSB04.08	Recollect basic principle, construction, types and attenuation of optical fibers.
AHSB04.09	Understand the importance of optical fibers in real-time communication system.
AHSB04.10	Apply different laws of radiation to understand the phenomenon behind production of light.
AHSB04.11	Apply the phenomenon of interference in thin films using Newton's rings experiment.
AHSB04.12	Identify diffraction phenomenon due to slits
AHSB04.13	Acquire knowledge of basic harmonic oscillators and discuss in detail different types of harmonic oscillators
AHSB04.14	Describe the steady state motion of forced damped harmonic oscillator
AHSB04.15	Acquire knowledge of reflection and transmission of waves at a boundary of media

SYLLABUS

Module-I	QUANTUM MECHANICS
Introduction to quantum physics, Black body radiation, Planck's law, Photoelectric effect, Compton effect, De- Broglie's hypothesis, Wave-particle duality, Davisson and Germer experiment, Time-independent Schrodinger equation for wave function, Born interpretation of the wave function, Schrodinger equation for one dimensional problems–particle in a box.	
Module-II	INTRODUCTION TO SOLIDS AND SEMICONDUCTORS
Bloch's theorem for particles in a periodic potential, Kronig-Penney model (Qualitative treatment), Origin of energy bands. Types of electronic materials: metals, semiconductors, and insulators. Intrinsic and extrinsic semiconductors, Carrier concentration, Dependence of Fermi level on carrier-concentration and temperature, Carrier generation and recombination, Hall effect.	
Module-III	LASERS AND FIBER OPTICS
Characteristics of lasers, Spontaneous and stimulated emission of radiation, Metastable state, Population inversion, Lasing action, Ruby laser, He-Ne laser and applications of lasers. Principle and construction of an optical fiber, Acceptance angle, Numerical aperture, Types of optical fibers (Single mode, multimode, step index, graded index), Attenuation in optical fibers, Optical fiber communication system with block diagram.	
Module-IV	LIGHT AND OPTICS
Huygens' principle, Superposition of waves and interference of light by wave front splitting	

<p>and amplitude splitting; Young's double slit experiment, Newton's rings, Michelson interferometer. Fraunhofer diffraction from a single slit, circular aperture and diffraction grating.</p>	
Module-V	HARMONIC OSCILLATIONS AND WAVES IN ONE DIMENSION
<p>Mechanical and electrical simple harmonic oscillators, Damped harmonic oscillator, Forced mechanical and electrical oscillators, Impedance, Steady state motion of forced damped harmonic oscillator. Transverse wave on a string, the wave equation on a string, Harmonic waves, Reflection and transmission of waves at a boundary, Longitudinal waves and the wave equation for them, acoustics waves.</p>	
Text Books:	
<ol style="list-style-type: none"> 1. Dr. K. Vijaya Kumar, Dr. S. Chandralingam, "Modern Engineering Physics", Chand & Co. New Delhi, 1st Edition, 2010. 2. I. G. Main, "Vibrations and waves in physics", Cambridge University Press, 1993. 3. R. K. Gaur, S. L. Gupta, "Engineering Physics", Dhanpat Rai Publications, 8th Edition, 2001. 	
Reference Books:	
<ol style="list-style-type: none"> 1. H.J. Pain, "The physics of vibrations and waves", Wiley, 2006. 2. A. Ghatak, "Optics", McGraw Hill Education, 2012. 3. O. Svelto, "Principles of Lasers", Springer Science & Business Media, 2010. 	

MODULE-I

PRINCIPLES OF QUANTUM MECHANICS

Introduction

At the end of nineteenth century, physicists had every reason to regard the Newtonian laws governing the motion of material bodies and Maxwell's laws of electromagnetism, as fundamental laws of physics. They believed that there should be some limitation on the validity of these laws which constitute classical mechanics. To understand the submicroscopic world of the atom and its constituents, it became necessary to introduce new ideas and concepts which led to which led to the mathematical formulation of quantum mechanics. That had an immediate and spectacular success in the explanation of the experimental observations.

Quantum mechanics is the science of the submicroscopic. It explains the behavior of matter and its interactions with energy on the scale of atoms and its constituents.

Light behaves in some aspects like particles and in other aspects like waves. Quantum mechanics shows that light, along with all other forms of electromagnetic radiation, comes in discrete units, called photons, and predicts its energies, colors, and spectral intensities. A single photon is a quantum, or smallest observable amount, of the electromagnetic field because a partial photon has never been observed.

Considering the above facts, it appears difficult to accept the conflicting ideas that radiation has a dual nature, i.e., radiation is a wave which is spread out over space and also a particle which is localized at a point in space. However, this acceptance is essential because radiation sometimes behaves as a wave and at other times as a particle as explained below:

(1) Radiations including visible light, infra-red, ultraviolet, X-rays, etc. behave as waves in experiments based on interference, diffraction, etc. This is due to the fact that these phenomena require the presence of two waves at the same position at the same time. Obviously, it is difficult for the two particles to occupy the same position at the same time. Thus, we conclude that radiations behave like wave..

(2) Planck's quantum theory was successful in explaining black body radiation, the photo electric effect, the Compton Effect, etc. and had clearly established that the radiant energy, in its interaction with matter, behaves as though it consists of corpuscles. Here radiation interacts with matter in the form of photon or quanta. Thus, we conclude that radiations behave like particle.

Black body radiation

A body that completely absorbs all wavelengths of radiation incident on it at low temperatures or emits different wave lengths of radiation at higher temperatures is known as a black body.

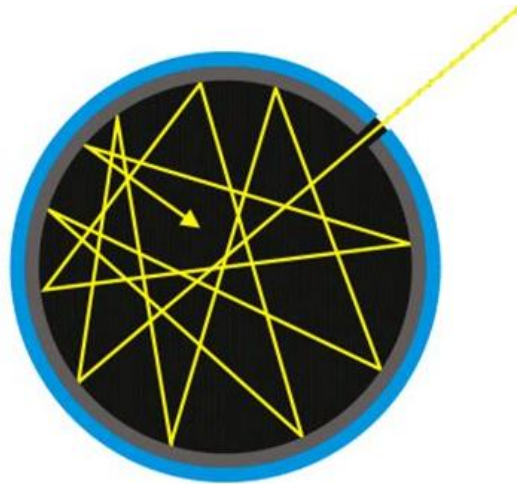

Figure 1 Black body

An approximate realization of a black surface is a hole in the wall of a large enclosure. Any light entering the hole is reflected within the internal surface of the body indefinitely or absorbed within the body and is unlikely to re-emerge, making the hole a nearly perfect absorber. The radiation confined in such an enclosure may or may not be in thermal equilibrium, depending upon the nature of the walls and the other contents of the enclosure.

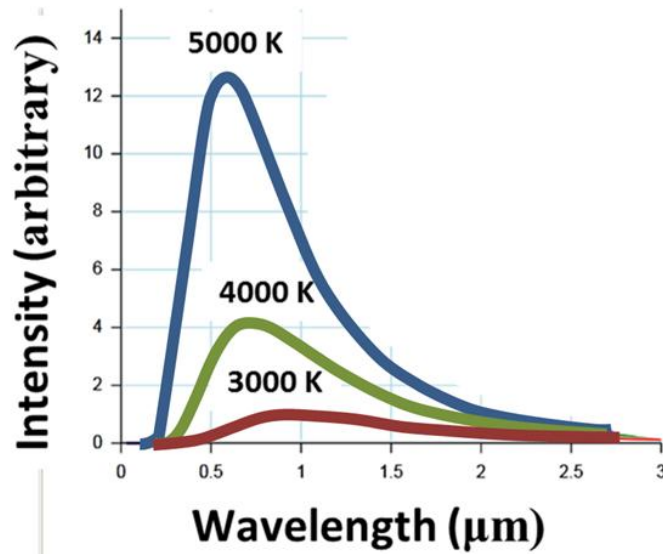

Figure 2 Black body radiation distribution

Plank's law

Plank assumed that the walls of the black body consist of large number of electrical oscillators, vibrating with their own natural frequencies. An oscillator possesses energy equal to $h\nu$. Where h is Planks constant and ν is the frequency of oscillator.

An oscillator may lose or gain energy by emitting or by absorbing photons respectively. Plank derived an equation for the energy per unit volume of black body in the entire spectrum of black body radiation. The spectral radiance of a body, B_ν , describes the amount of energy it gives

off as radiation of different frequencies. It is measured in terms of the power emitted per unit area of the body, per unit solid angle that the radiation is measured over, per unit frequency. Planck showed that the spectral radiance of a body for frequency ν at absolute temperature T is given by

$$E(\lambda, T) = \frac{2hc^2}{\lambda^5} * \frac{1}{\exp\left(\frac{hc}{\lambda kT}\right) - 1} \text{-----(1)}$$

Where k is the Boltzmann constant, h is the Planck constant, and c is the speed of light in the medium, whether material or vacuum. The spectral radiance can also be expressed per unit wavelength λ instead of per unit frequency.

Photoelectric effect

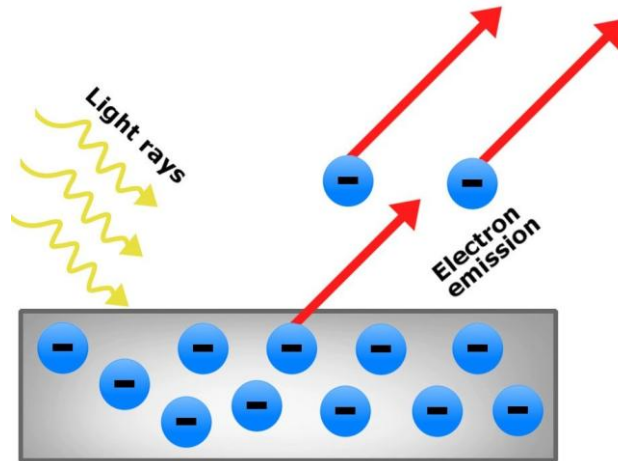

Figure 3 Photoelectric effect

The photoelectric effect is the emission of electrons or other free carriers when light shines on a material. Electrons emitted in this manner can be called photo electrons. This phenomenon is commonly studied in electronic physics, as well as in fields of chemistry, such as quantum chemistry or electrochemistry.

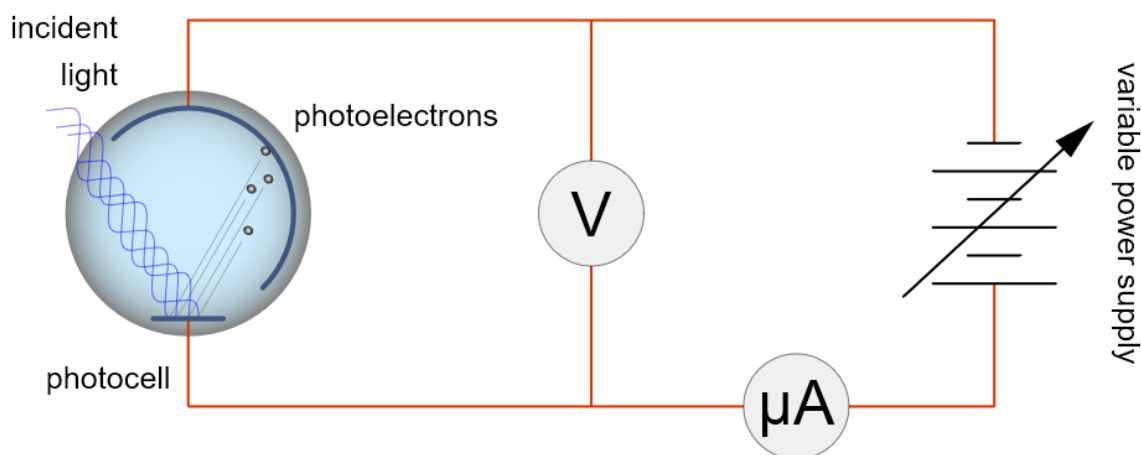

Figure 4 Black diagram of Photo electric effect

Einstein assumed that a photon would penetrate the material and transfer its energy to an electron. As the electron moved through the metal at high speed and finally emerged from the material, its kinetic energy would diminish by an amount ϕ called the work function (similar to the electronic work function), which represents the energy required for the electron to escape the metal. By conservation of energy, this reasoning led Einstein to the photoelectric equation $E_k = hf - \phi$, where E_k is the maximum kinetic energy of the ejected electron.

Compton Effect

It is defined as scattering of a photon by a charged particle like an electron. It results in a decrease in energy of the photon called the Compton Effect. Part of the energy of the photon is transferred to the recoiling electron.

The interaction between an electron and a photon results in the electron giving part of the energy (making it recoil) and a photon of the remaining energy being emitted in a different direction from the original, so that the overall momentum of the system is also conserved. If the scattered photon still has enough energy, the process may be repeated. In this scenario, the electron is treated as free or loosely bound.

Compton derived the mathematical relationship between the shift in wavelength and the scattering angle of the X-rays by assuming that each scattered X-ray photon interacted with only one electron. His paper concludes by reporting on experiments which verified his derived relation:

$$(\lambda^1 - \lambda) = \frac{h}{m_o c} (1 - \cos \theta) \text{-----}(2)$$

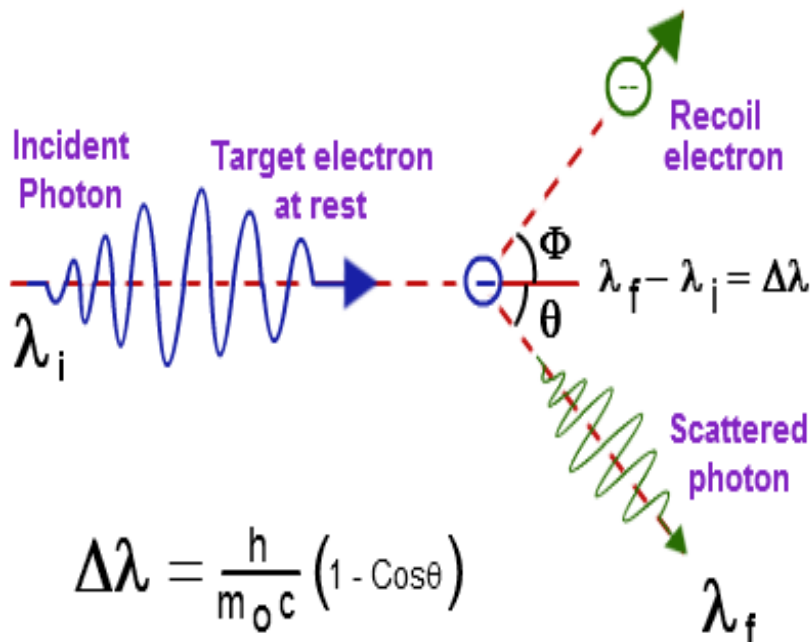

Figure 5 Compton Effect

de- Broglie Hypothesis

In quantum mechanics, matter is believed to behave both like a particle and a wave at the sub-microscopic level. The particle behavior of matter is obvious. When you look at a table, you think of it like a solid, stationary piece of matter with a fixed location. At this macroscopic scale, this holds true. But when we zoom into the subatomic level, things begin to get more complicated, and matter doesn't always exhibit the particle behavior that we expect.

This non-particle behavior of matter was first proposed in 1923, by Louis de Broglie, a French physicist. In his PhD thesis, he proposed that particles also have wave-like properties. Although he did not have the ability to test this hypothesis at the time, he derived an equation to prove it using Einstein's famous mass-energy relation and the Planck equation. These waves associated with particles are named de- Broglie waves or matter waves.

Expression for de- Broglie wavelength

The expression of the wavelength associated with a material particle can be derived on the analogy of radiation as follows:

Considering the plank's theory of radiation, the energy of photon (quantum) is

$$E = h\nu = \frac{hc}{\lambda} \quad \rightarrow (3)$$

Where c is the velocity of light in vacuum and λ is its wave length.

According to Einstein energy – mass relation

$$E = mc^2 \quad \rightarrow (4)$$

$$\lambda = \frac{h}{mc} = \frac{h}{p} \quad \rightarrow (5)$$

Where $mc = p$ is momentum associated with photon.

If we consider the case of material particle of mass m and moving with a velocity v , i.e momentum mv , then the wave length associated with this particle (in analogy to wave length associated with photon) is given by

$$\lambda = \frac{h}{mv} = \frac{h}{p} \quad \rightarrow (6)$$

Different expressions for de-Broglie wavelength

(a) If E is the kinetic energy of the material particle then

$$E = \frac{1}{2}mv^2 = \frac{1}{2} \frac{m^2v^2}{m} = \frac{p^2}{2m}$$

$$\Rightarrow p^2 = 2mE \text{ or } p = \sqrt{2mE}$$

$$\text{Therefore de- Broglie wave length } \lambda = \frac{h}{\sqrt{2mE}} \quad \rightarrow (7)$$

(b) When a charged particle carrying a charge ‘ q ’ is accelerated by potential difference v , then its kinetic energy $K.E$ is given by

$$E = qV$$

Hence the de-Broglie wavelength associated with this particle is

$$\lambda = \frac{h}{\sqrt{2mqV}} \quad \rightarrow (8)$$

For an electron $q = 1.602 \times 10^{-19}$

Mass $m = 9.1 \times 10^{-31}$ kg

$$\therefore \lambda = \frac{6.626 \times 10^{-34}}{\sqrt{2 \times 9.1 \times 10^{-31} \times 1.602 \times 10^{-19} V}}$$

$$= \sqrt{\frac{150}{V}} = \frac{12.26}{\sqrt{V}} \text{ \AA} \quad \rightarrow (9)$$

Properties of Matter Waves

Following are the properties of matter waves:

(a) Lighter is the particle, greater is the wavelength associated with it.

(b) Smaller is the velocity of the particle, greater is the wavelength associated with it.

(c) When $v = 0$, then $\lambda = \infty$, i.e. wave becomes indeterminate and if $v = \infty$ then

$\lambda = 0$. This shows that matter waves are generated only when material particles are in motion.

(d) Matter waves are produced whether the particles are charged particles or not

($\lambda = \frac{h}{mv}$ is independent of charge). i.e., matter waves are not electromagnetic waves but they are a new kind of waves.

- (e) It can be shown that the matter waves can travel faster than light i.e. the velocity of matter waves can be greater than the velocity of light.
- (f) No single phenomenon exhibits both particle nature and wave nature simultaneously.

Distinction between matter waves and electromagnetic waves

S.No	Matter Waves	Electromagnetic Waves
1	Matter waves are associated with moving particles (charged or uncharged)	Electromagnetic waves are produced only by accelerated charged particles.
2	Wavelength depends on the mass of the particle and its velocity, $\lambda = \frac{h}{mv}$	Wavelength depends on the energy of photon
3	Matter waves can travel with a velocity greater than the velocity of light. Matter wave is not electromagnetic wave.	Travel with velocity of light $c = 3 \times 10^8$ m/s
4.	Matter wave require medium for propagation, i.e, they cannot travel through vacuum.	Electric field and magnetic field oscillate perpendicular to each other.
5.		Electromagnetic waves do not require any medium for propagation, i.e., they can pass through vacuum.

Davisson and Germer's Experiment

The first experimental evidence of matter waves was given by two American physicists, Davisson and Germer in 1927. The experimental arrangement is shown in figure 3.1(a).

The apparatus consists of an electron gun G where the electrons are produced. When the filament of electron gun is heated to dull red electrons are emitted due to thermionic emissions. Now, the electrons are accelerated in the electric field of known potential difference. These electrons are collimated by suitable slits to obtain a fine beam which is then directed to fall on a large single crystal of nickel, known as target T which is rotated about an angle along the direction of the beam is detected by an electron detector (Faraday cylinder) which is connected to a galvanometer. The Faraday cylinder 'c' can move on a circular graduated scale s between 29° to 90° to receive the scattered electrons.

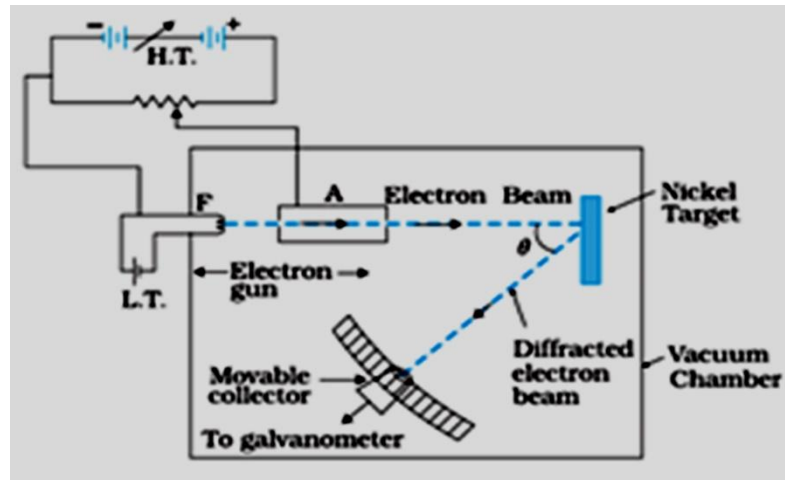

Figure 6 Davisson and Germer's experimental arrangement for verification of matter waves

First of all, the accelerating potential V is given a low value and the crystal is set at any orbital azimuth (θ). Now the Faraday cylinder is moved to various positions on the scale's and galvanometer current is measured for each position. A graph is plotted between galvanometer current against angle θ between incident beam and beam entering the cylinder [Figure 3.1(b)]. The observations are repeated for different acceleration potentials.

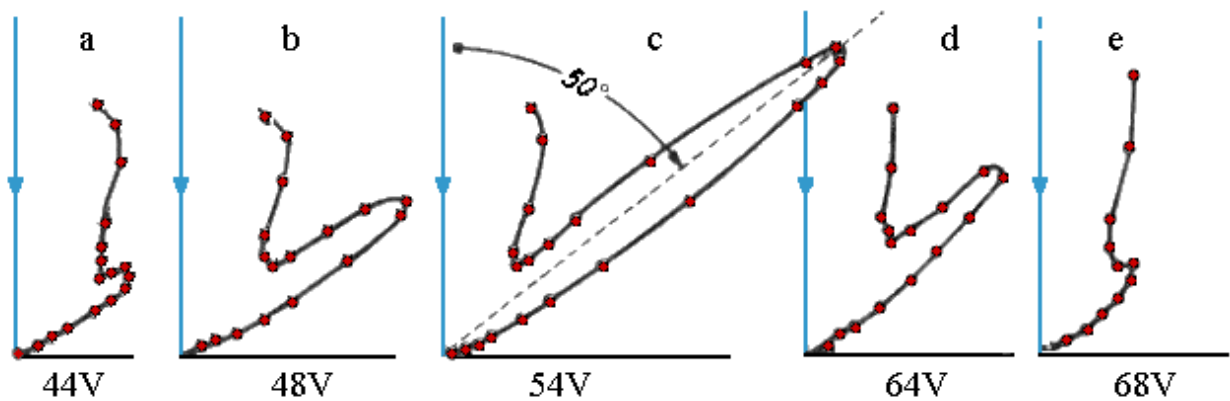

Figure 7 Variation of Galvanometer current with variation of angle θ between incident beam and beam entering the cylinder

It is observed that a 'bump' begins to appear in the curve for 44 volts. Following points are observed.

- With increasing potential, the bump moves upwards.
- The bump becomes most prominent in the curve for 54 volts at $\theta = 50^\circ$.
- At higher potentials, the bumps gradually disappear.

The bump in its most prominent state verifies the existence of electron waves. According to de-Broglie, the wavelength associated with electron accelerated through a potential V is given by

$$\lambda = \frac{12.26}{\sqrt{V}} \text{ \AA}.$$

Hence, the wavelength associated with an electron accelerated through 54 volt is

$$\lambda = \frac{12.26}{\sqrt{54}} = 1.67 \text{ \AA}$$

From X-ray analysis, it is known that a nickel crystal acts as a plane diffraction grating with space $d = 0.91 \text{ \AA}$ [see Figure 3.1(c)]. According to experiment, we have diffracted electron beam at $\theta = 50^\circ$. The corresponding angle of incidence relative to the family of Bragg plane

$$\theta^i = \frac{180-50}{54} = 65^\circ$$

Using Bragg's equation (taking $n=1$), we have

$$\begin{aligned} \lambda &= 2d\sin\theta \\ &= 2(0.91\text{\AA}) \sin 65^\circ \end{aligned}$$

This is in good agreement with the wavelength computed from de-Broglie hypothesis.

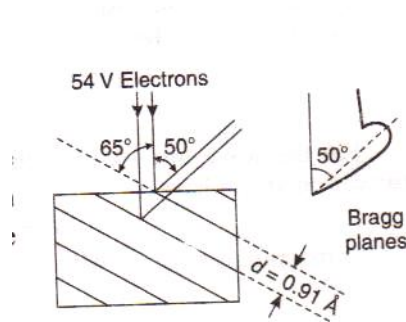

Figure 8 Bragg planes in Nickel crystal

As the two values are in good agreement, hence, confirms the de-Broglie concept of matter waves.

Schrodinger's time independent wave equation

Schrodinger developed a differential equation whose solutions yield the possible wave functions that can be associated with a particle in a given situation. This equation is popularly known as Schrodinger equation. The equation tells us how the wave function changes as a result of forces acting on the particle. One of its forms can be derived by simply incorporating the de-Broglie wavelength expression into the classical wave equation.

If a particle of mass 'm' moving with velocity v is associated with a group of waves, let ψ be the wave function of the particle. Also let us consider a simple form of progressing wave represented by the equation

$$\psi = \psi_0 \sin(\omega t - kx) \text{ -----(1)}$$

Where $\psi = \psi(x, t)$

ψ_0 is amplitude

Differentiating eq (1) partially with respect to 'x', we get

$$\frac{\partial \psi}{\partial x} = -K \psi_0 \cos(\omega t - kx)$$

Again differentiating equation (1) with respect to 'x'

$$\frac{\partial^2 \psi}{\partial x^2} = -K^2 \psi_0 \sin(\omega t - kx)$$

$$\frac{\partial^2 \psi}{\partial x^2} = -k^2 \psi$$

$$\frac{\partial^2 \psi}{\partial x^2} + k^2 \psi = 0 \quad \text{----- (2)}$$

$$\text{Since } k = \frac{2\pi}{\lambda}, \quad \frac{\partial^2 \psi}{\partial x^2} + \frac{4\pi^2}{\lambda^2} \psi = 0 \quad \text{----- (3)}$$

Eq (2) or Eq (3) is the differential form of the classical wave equation. Now, incorporating de-Broglie wavelength expression $\lambda = \frac{h}{mv}$ in to eq (3), we get

$$\frac{\partial^2 \psi}{\partial x^2} + \frac{4\pi^2 m^2 v^2}{h^2} \psi = 0 \quad \rightarrow (4)$$

The total energy E of the particle is the sum of its kinetic energy k and potential energy V

$$\text{i.e., } E = K + V$$

$$\text{But } K = \frac{1}{2} mv^2$$

$$\therefore E = \frac{1}{2} mv^2 + V$$

$$\frac{1}{2} mv^2 = E - V$$

$$m^2 v^2 = 2m(E - V) \quad \rightarrow (5)$$

Substituting eq (5) in eq (4), we get

$$\frac{\partial^2 \psi}{\partial x^2} + \frac{8\pi^2 m(E - V)}{h^2} \psi = 0 \quad \rightarrow (6)$$

In quantum mechanics, the value $\frac{h}{2\pi}$ occurs most frequently. Hence we denote $\hbar = \frac{h}{2\pi}$ using this notation, we have

$$\frac{\partial^2 \psi}{\partial x^2} + \frac{2m(E - V)}{\hbar^2} \psi = 0 \quad \rightarrow (7)$$

For simplicity, we have considered only one dimensional wave extending eq(7) for a 3 – dimensional wave

$$\frac{\partial^2 \psi}{\partial x^2} + \frac{\partial^2 \psi}{\partial y^2} + \frac{\partial^2 \psi}{\partial z^2} + \frac{2m(E - V)}{\hbar^2} \psi = 0 \quad \rightarrow (8)$$

Where $\psi(x, y, z)$; here, we have considered only stationary states of ψ after separating the time dependence of ψ

The Laplacian operator is defined as

$$\nabla^2 = \frac{\partial^2}{\partial x^2} + \frac{\partial^2}{\partial y^2} + \frac{\partial^2}{\partial z^2} \quad \rightarrow (9)$$

Hence eq (10) can be written as

$$\nabla^2 \psi + \frac{2m(E - V)}{\hbar^2} \psi = 0 \quad \rightarrow (10)$$

This is Schrodinger wave equation. Since time factor doesn't appear, eq(8) or eq(10) is called 'time independent Schrodinger wave equation' in three dimensions.

Physical significance of wave function ψ

- (1) The wave function ψ has no direct physical meaning. It is a complex quantity representing the variation of matter wave.
- (2) It connects the practical nature and its associated wave nature statically.
- (3) $|\psi|^2$ (or $\psi\psi^*$ if function is complex) at a point is proportional to the probability of finding the particle at that point at any given time. The probability density at any point is represented by $|\psi|^2$.
- (4) If the particle is present in a volume $dx dy dz$, then $|\psi|^2 dx dy dz = 1$

If a particle is present somewhere in space

$$\int_{-\infty}^{\infty} \psi^2 dx dy dz = 1$$

Or

$$\int_{-\infty}^{\infty} \psi\psi^* dx dy dz = 1$$

The wave function satisfying the above condition is said to be normalized.

Particle in Infinite square potential well

A free electron trapped in a metal or charge carriers trapped by barriers trapped by the potential barriers of a double hetero junction can be approximated by an electron in an infinitely deep one- dimensional potential well.

Consider one – dimensional potential well of width L as shown in fig. Let the potential $V = 0$ inside well and $V = \infty$ outside the well.

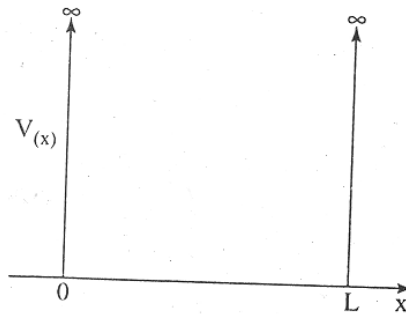

Fig.4.4 Square potential well infinite height

The time independent Schrödinger wave equation in one dimensional case

$$\frac{d^2\psi}{dx^2} + \frac{2m(E - V)}{\hbar^2} \psi = 0 \quad \rightarrow (1)$$

For a particle present inside the well where $V=0$ and $\psi = \psi(x)$

$$\frac{d^2\psi}{dx^2} + \frac{2mE}{\hbar^2}\psi = 0 \quad \rightarrow (2)$$

Let the general solution of eq (2) be

$$\psi(x) = A \sin kx + B \cos kx \quad \rightarrow (3)$$

Where A and B are constants which can be determined from boundary conditions

$$\left. \begin{array}{l} \psi(x) = 0 \text{ at } x = 0 \\ \text{And } \psi(x) = 0 \text{ at } x = L \\ \text{Since } \psi(x) = 0 \text{ at } x = 0 \\ 0 = A \sin k(0) + B \cos k(0) \end{array} \right\} \quad \rightarrow (4)$$

$$\Rightarrow B = 0 \quad \rightarrow (5)$$

$$\begin{array}{l} \text{Since } \psi(x) = 0 \quad \text{at } x = L \\ 0 = A \sin kL \end{array}$$

Which means $A=0$ or $\sin kL = 0$ since both A and B cannot be zero, $A \neq 0$. If $A = 0$, then $\psi = 0$ everywhere. This means that the particle is not in the well. The only meaningful way to satisfy the condition is

$$\begin{array}{l} \sin kL = 0, \\ \text{Or } kL = n\pi ; n = 1,2,3,\dots \\ \therefore k = \frac{n\pi}{L} \end{array} \quad \rightarrow (6)$$

Thus, eq (3) simplifies to

$$\psi(x) = A \sin \frac{n\pi}{L}x \quad \rightarrow (7)$$

Differentiating ψ in eq (7)

$$\frac{d\psi}{dx} = A \frac{n\pi}{L} \cos \frac{n\pi}{L}x$$

Again Differentiating, we get

$$\frac{d^2\psi}{dx^2} = -A \frac{n^2\pi^2}{L^2} \sin \frac{n\pi}{L}x$$

$$\frac{d^2\psi}{dx^2} = -\frac{n^2\pi^2}{L^2}\psi = 0$$

$$\frac{d^2\psi}{dx^2} + \frac{n^2\pi^2}{L^2}\psi = 0 \quad \rightarrow (8)$$

Comparing eq (2) and eq (8), we get

$$\frac{2mE}{\hbar^2} = \frac{n^2\pi^2}{L^2} = k^2$$

$$E = \frac{n^2\pi^2\hbar^2}{2mL^2}$$

n is called the quantum number. Thus we obtain an important result. The particle cannot possess any value of energy as assumed in classical case, but it possesses only discrete set of energy values.

The energy of the n^{th} quantum level,

$$E_n = \frac{n^2 \pi^2 \hbar^2}{2mL^2} = \frac{n^2 h^2}{8mL^2} \quad (\text{since } \hbar = \frac{h}{2\pi}) \quad \rightarrow (9)$$

The wave functions and the corresponding energy levels of the particles are as suggested in Figure 3.5

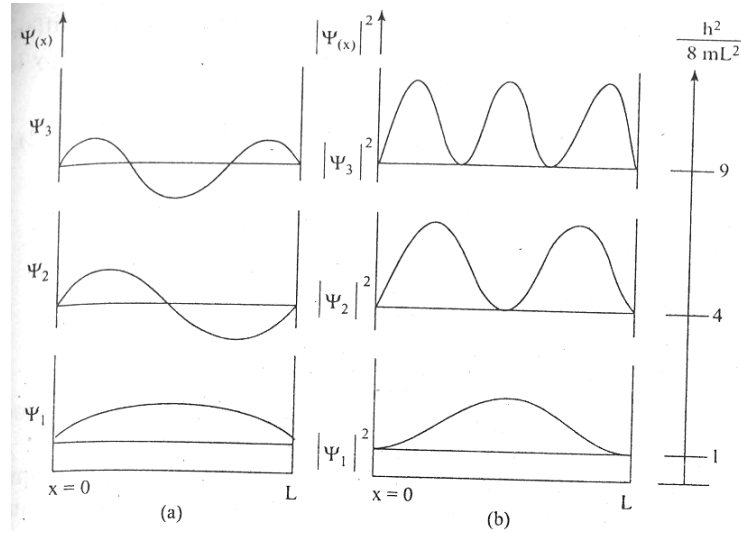

Fig.4.5 Ground state and first two excited states of an electron in a potential well: a) the electron wave functions and b) the corresponding probability density functions. The energies of these three states are shown on the right.

We are still left with an arbitrary constant 'A' in eq (7). It can be obtained by applying normalization condition i.e.; the probability of finding the particle inside the box is unity.

$$\int_0^L |\psi|^2 dx = 1$$

$$\int_0^L A^2 \sin^2 \frac{n\pi x}{L} dx = 1$$

$$A^2 \int_0^L \frac{1}{2} \left[1 - \cos \frac{2n\pi}{L} x \right] dx = 1$$

$$\frac{A^2}{2} \left[x - \frac{L}{2\pi n} \sin \frac{2\pi n x}{L} \right]_0^L = 1$$

$$\Rightarrow \frac{A^2}{2} [(L - 0) - (0 - 0)] = 1$$

$$\frac{A^2 L}{2} = 1 \text{ or } A = \sqrt{\frac{2}{L}} \quad \rightarrow (10)$$

∴ The normalized wave function is

$$\psi_n = \sqrt{\frac{2}{L}} \sin \frac{n\pi x}{L} \quad \rightarrow (11)$$

Notice that the number of nodes (places where the particle has zero probability of being located) increases with increasing energy n. Also note that as the energy of the particle becomes greater,

the quantum mechanical model breaks down due to the energy levels get closer together and overlap, forming a continuum. This continuum means the particle is free and can have any energy value. At such high energies, the classical mechanical model is applied as the particle behaves more like a continuous wave. Therefore, the particle in a box problem is an example of Wave-Particle Duality.

MODULE-II

INTRODUCTION TO SOLIDS AND SEMICONDUCTORS

Bloch's theorem

Crystalline solid consists of a lattice which is composed of a large number of ionic cores at regular intervals and the conduction electrons move throughout the lattice.

Let us consider the picture of the lattice in only one dimension, i.e., only an array of ionic cores along x-axis. If we plot the potential energy of a conduction electron as a position in the lattice, the variation of potential energy is as shown in figure. The potential is minimum at the positive ion sites and maximum between the two ions.

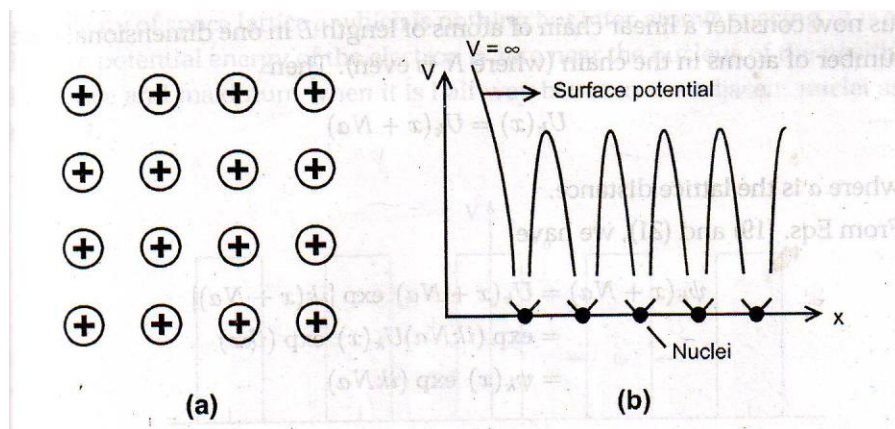

periodic positive ion cores inside metallic crystals. b) One dimensional periodic potential in crystal.

The one dimension Schrodinger equation corresponding to this can be written as

$$\frac{d^2\psi}{dx^2} + \frac{8\pi^2m}{h^2}[E-V(x)] \psi = 0 \quad \rightarrow (1)$$

The periodic potential V(x) may be defined by means of the lattice constant 'a' as

$$V(x) = V(x+a) \quad \rightarrow (2)$$

Bloch considered the solution as

$$\psi_k(x) = \exp(ikx)U_k(x) \quad \rightarrow (3)$$

Eqn (2) is known as Bloch function. $U_k(x)$ is periodic with the periodicity of the crystal lattice. The free electron wave is modulated by periodic function $U_k(x)$ is periodic with the periodicity of the crystal lattice. The free electron wave is modulated by periodic function $U_k(x)$. For a linear chain of atoms of length 'L' in one dimensional case with 'N' (= even) number of atoms in the chain,

$$U_k(x) = U_k(x+Na) \quad \rightarrow (4)$$

From eqn (3) and eqn (4)

$$\begin{aligned} \Psi_k(x+na) &= U_k(x+Na) e^{[ik(x+Na)]} \\ &= e^{(ikNa)} U_k(x) e^{(ikx)} \\ &= \psi_k(x) e^{(ikNa)} \end{aligned} \quad \rightarrow (5)$$

This is referred to as Bloch condition.

Now,

$$\begin{aligned}\psi_k(x+Na)\psi_k^*(x+Na) &= \psi_k(x)e^{(ikNa)}\psi_k^*(x)e^{(-ikNa)} \\ &= \psi_k(x)\psi_k^*(x)e^{(0)} \\ \Psi_k(x+Na)\Psi_k^*(x+Na) &= \Psi_k(x)\Psi_k^*(x) \quad \rightarrow (6)\end{aligned}$$

This means that the electron is not located around any particular atom and the probability of finding the electron is same throughout the crystal.

The Kronig-Penny Model

The periodic potential assumed by Kronig and Penny is shown in Figure. i.e., a series of rectangular wells of width 'a' and are placed at a separation of b. in the regions where $0 < x < a$, the potential energy is zero and in regions such as $-b < x < 0$, the potential energy is V_0 .

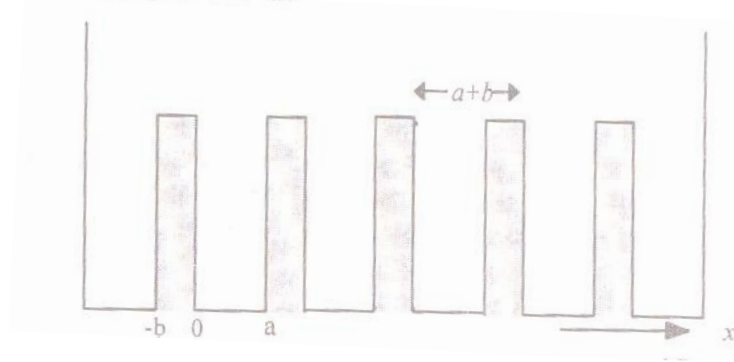

One dimensional periodic potential assumed by Kronig and Penny

The main features of the model and its predictions can be explained qualitatively

Main features of the model

A. Schrodinger equation:

The dynamical behavior of electrons in the Kronig-Penny model is represented by the following Schrodinger equation,

$$\frac{d^2\psi}{dx^2} + \left[\frac{2m}{\hbar^2}\right] E\psi = 0 \quad \text{for } 0 < x < a$$

And

$$\frac{d^2\psi}{dx^2} + \left[\frac{2m}{\hbar^2}\right] (E - V_0)\psi = 0 \quad \text{for } -b < x < 0 \quad \rightarrow (1)$$

Let us assume that total energy 'E' of the electron under consideration is less than V_0 .

$$\text{Further, let us substitute } \alpha^2 = \frac{2mE}{\hbar^2} \quad \text{and} \quad \beta^2 = \frac{2m}{\hbar^2}(V_0 - E) \quad \rightarrow (2)$$

Where α and β are real quantities.

Now Eq(1) becomes

$$\frac{d^2\psi}{dx^2} + \alpha^2\psi = 0, \quad \text{for } 0 < x < a$$

And

$$\frac{d^2\psi}{dx^2} - \beta^2\psi = 0, \quad \text{for } -b < x < 0 \quad \rightarrow (3)$$

These equations can be solved with the help of block theorem. The final solution of eq (3) is given in the form of the following condition.

$$P \frac{\sin \alpha a}{\alpha a} + \cos \alpha a = \cos k a \quad \rightarrow (4)$$

Where $P = \frac{mb}{h^2} V_0 a$ is scattering power of the potential barrier and V_0 is barrier strength. That means, eq (3) will have a solution only when the condition (4) is satisfied.

Graph of αa versus $\frac{P \sin \alpha a}{\alpha a} + \cos \alpha a$

For the best understanding of the meaning of eq(4), let us consider the plot of the condition(4) i.e. L.H.S versus αa . Since the values of $\cos k a$ on R.H.s of eq (4) lie between +1 and -1, αa (which is a measure of energy) can take only those values for which the total left hand side (L.H.S) value lies between -1 and +1. Other values are not allowed. This means that energy E is restricted to lie within certain ranges which form the allowed energy bands or zones.

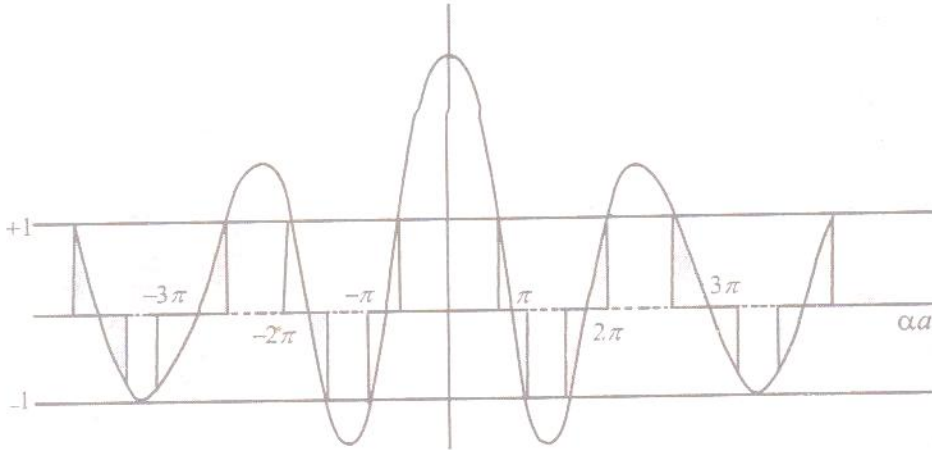

Plot of the left hand side of eq (4) as a function of αa for $p = \frac{3\pi}{2}$. The solid and broken lines on the abscissa (αa - axis) correspond to allowed and forbidden energy regions of the energy spectrum respectively that are plotted in fig.

Conclusions of the graph

1. The energy spectrum consists of alternative regions of allowed and vacant bands. Forbidden band implies that the energy levels that lie in this region are not occupied by the electrons.
2. The allowed (shaded) bands are narrowest for low values of energy and become broader as energy increases, the unallowed (forbidden) bands becoming narrower.
3. a) For $P=0$ (i.e. on the extreme left), the whole energy spectrum is quasi-continuous. That is all allowed bands are joined together forming an almost continuum.
b) However, the width of a particular allowed band decreases with increase in the value of P . As $P \rightarrow \infty$, the allowed energy bands compress into simple energy levels and thus result in a line spectrum.

Origin of Energy band formation in solids

In an isolated atom, the electrons are tightly bound and have discrete, sharp energy levels [Figure]. When two identical atoms are brought closer, the outermost orbits of these atoms overlap and interact.

When the wave functions of the electrons of the different atoms begin to overlap considerably, the energy levels split into two

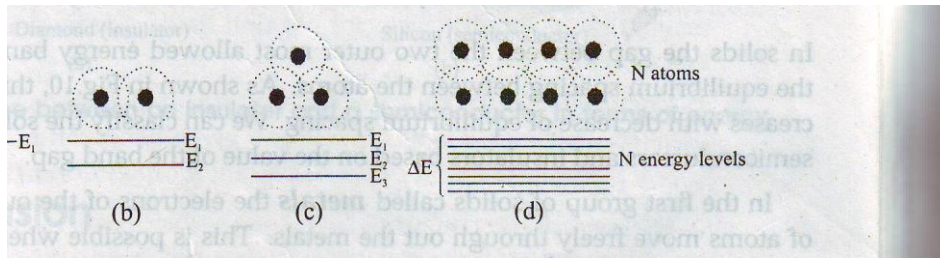

. Splitting of energy levels due to interatomic interaction

If more atoms are brought together, more levels are formed and for a solid of N atoms, each of the energy levels of an atom splits into N levels of energy [Figure].

The levels are so close together that they form an almost continuous band. The width of this band depends on the degree of overlap of the electrons of adjacent atoms and is largest for the outermost atomic electrons.

In a solid, many atoms are brought together that the split energy levels form a set of energy bands of very closely spaced levels with forbidden energy gaps between them. Overlapping of these atoms occurs for smaller equilibrium spacing r_0 .

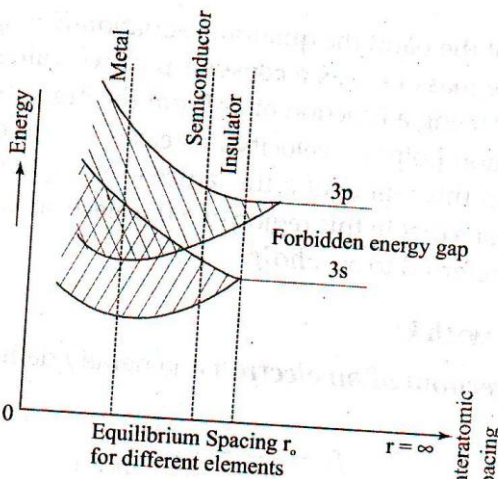

. With decrease of interatomic spacing overlapping of energy bands take place

The band corresponding to outermost orbit is called conduction band and the next band is called valence band. The gap between these two allowed bands is called forbidden energy gap or band gap. According to the width of the gap between the bands and band occupation by electrons all solids can be classified broadly into three groups namely, conductors, semiconductors and insulators

Classification of materials into conductors, semiconductors and insulators

On the basis of band theory, solids can be broadly classified into three categories, viz, insulators, semiconductors and conductors. Their band structures can be as shown in figure.

Insulators

1. In case of insulators, the forbidden gap is very wide. Due to this fact electrons cannot jump from valence band to conduction band.
2. They have completely filled valence band and completely empty conduction band.
3. The resistivity of insulators is very high.
4. Insulators are bad conductors of electricity.

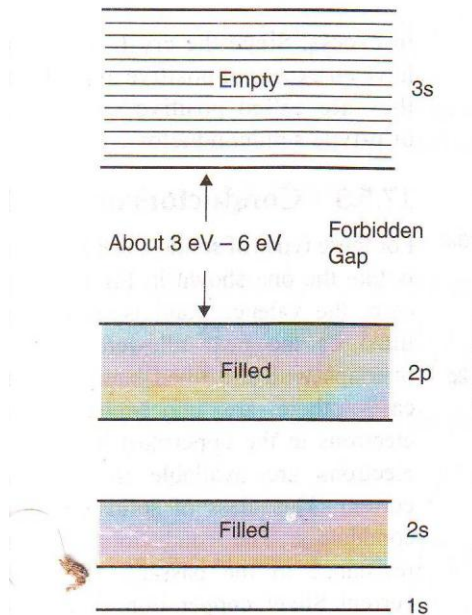

.Valence and conduction bands of insulator separated by large band gap

Semiconductors

1. In semiconductors, the band gap is very small (0.7 eV for germanium and 1.1 eV for silicon).
2. At 0k, there are no electrons in the conduction band and the valence band is completely filled.
As the **temperature increases, electrons** from the valence band jump into conduction band
3. . 3. The resistivity varies from 10^{-14} to $10^7 \Omega$ meter.
4. They have electrical properties between those of insulators and conductors.

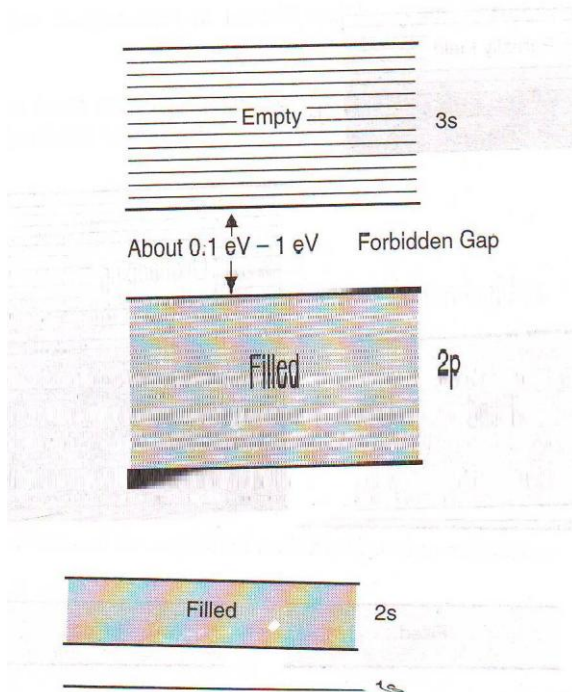

. Valence and conduction bands of semiconductor separated by small band gap

Conductors

1. In case of conductors, there is no forbidden gap and the valence band conduction band overlaps each other.
2. Plenty of free electrons are available for electrical conduction.
3. They possess very low resistivity and very high conductivity values.
4. Metals like copper, iron etc. are best examples of conductors.

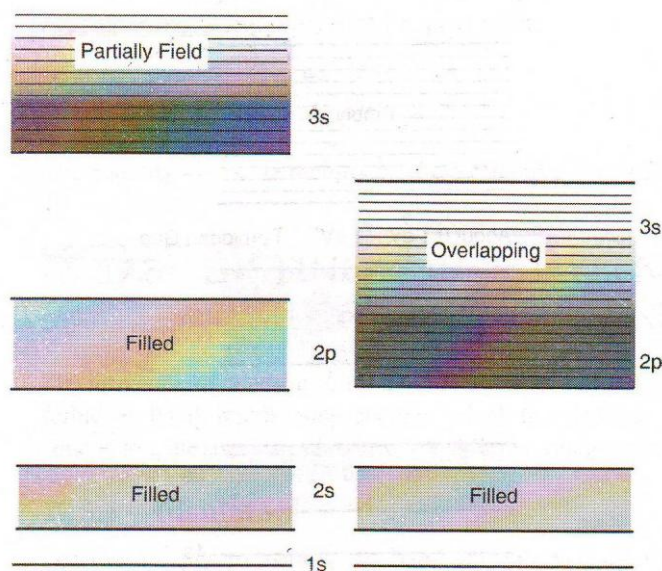

. Metals having (a) partially filled valence band and (b) overlap of completely filled valence band

Intrinsic Semiconductor

Pure germanium or silicon called an intrinsic semiconductor. Each atom possesses four valence electrons in outer most orbits. At $T = 0\text{K}$ a 2-D representation of the crystal of silicon & band diagram is shown in the figure.

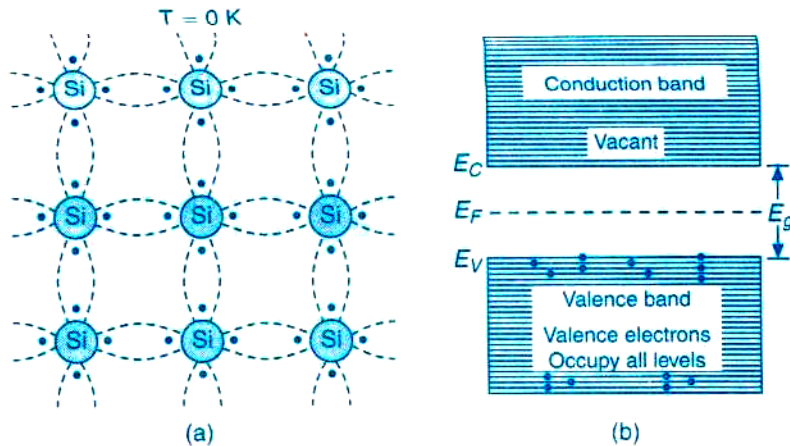

Intrinsic silicon crystal at $T = 0\text{K}$ (a) 2-D representation of silicon crystal
(c) Energy band diagram of intrinsic semiconductor

Explanation: At 0K , all the valence electrons of silicon atoms are in covalent bonds and their energies constitute a band of energies called valance band (VB). So at 0K , VB is completely filled & conduction band (CB) is empty.

If we rise temperature ($T > 0\text{K}$), some of the electrons which are in covalent bonds break the bonds become free and move from VB to CB. The energy required should be greater than the energy gap of a semiconductor ($E > E_g$). The electron vacancy or deficiency created in VB is called holes. This is shown in the figure 3 below.

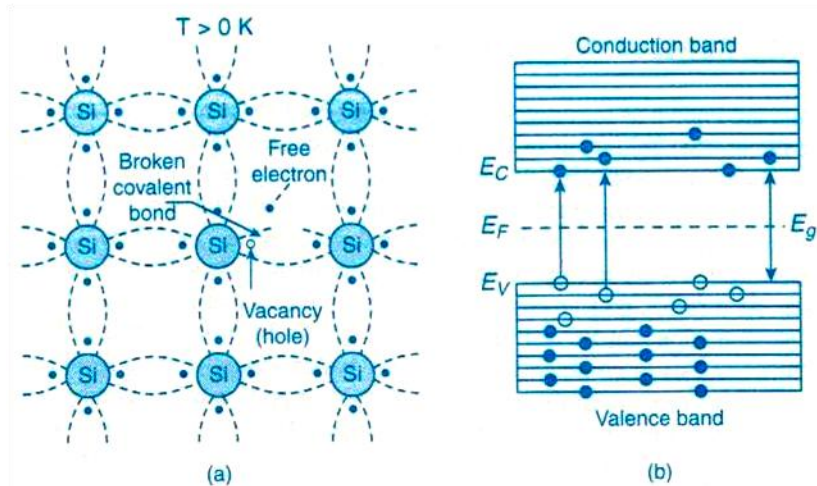

Silicon crystal at temperature above 0K (a) Due to thermal energy breaking of Covalent bonds take place (b) Energy band representation

Electron concentration in intrinsic semiconductor in conduction band (n)

Definition: The no. of free electrons per unit volume of the conduction band of a given intrinsic semiconductor is called electron concentration, represented by 'n'.

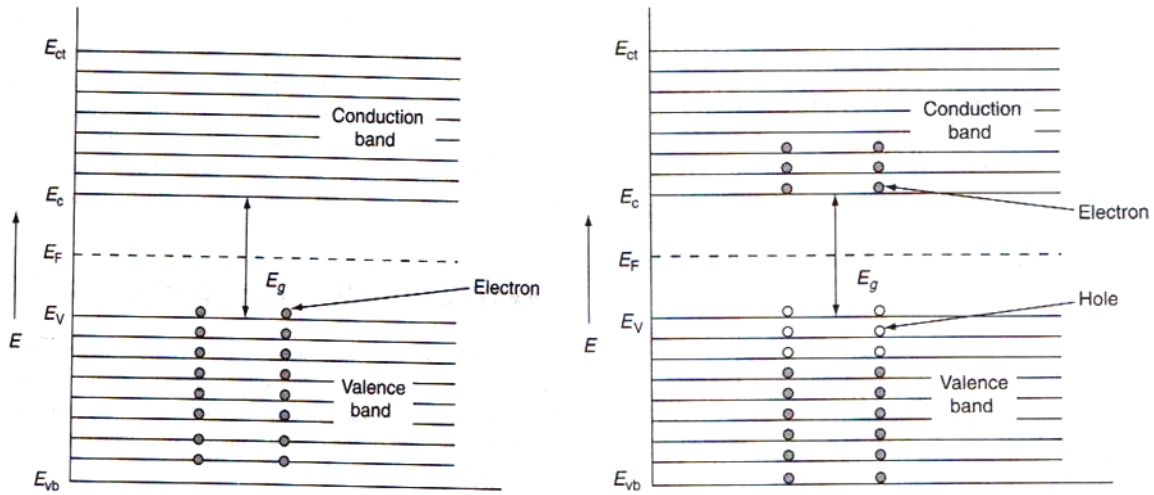

(a) Energy band diagram of silicon at $T = 0K$

(b) Energy band diagram of silicon at $T > 0K$

Derivation: Let the no. of free electrons per unit volume of the semiconductor having energies E and $E + dE$ in CB is represented by $n(E) dE$. It is obtained by multiplying the density of energy states $Z_C(E) d(E)$. [No. of energy states per unit volume] and Fermi - Dirac distribution function for the Probability of occupation of electrons $F_C(E)$

Therefore $n(E) dE = [Z_C(E) d(E)] [F_C(E)] \rightarrow (1)$

Where $Z_v(E) d(E) =$ Density of energy states

$F_h(E) =$ Probability of occupation of electrons given by Fermi - Dirac function

The total no. of electrons in CB per unit volume between the energies E_C to E_{ct} is given by integrating equation (1) with limits E_C to E_{ct}

$$n = \int_{E_C}^{E_{ct}} n(E) dE \rightarrow (2)$$

But equation (2) can be written as

$$n = \int_{E_C}^{\infty} n(E) dE + \int_{\infty}^{E_{ct}} n(E) dE \rightarrow (3)$$

$$n = \int_{E_C}^{\infty} n(E) dE - \int_{E_{ct}}^{\infty} n(E) dE \rightarrow (4)$$

In equation (4) the second term vanishes (disappears).

Since, above E_{ct} electrons do not present. Hence equation (4) becomes

$$n = \int_{E_C}^{\infty} n(E) dE$$

$$n = \int_{E_C}^{\infty} [Z_C(E) dE] \times [F_C(E)] \rightarrow (5)$$

{ Since from equation (1) }

But $[F_C(E)]$ is Fermi - Dirac distribution function;

$$F_C(E) = \frac{1}{1 + e^{\frac{E - E_F}{K_B T}}} \rightarrow (6)$$

Here $E > E_F$, i. e. $e^{\frac{E - E_F}{K_B T}} \gg 1$

Hence '1' can be neglected in equation (6)

$$F_C(E) = \frac{1}{e^{\frac{E-E_F}{K_B T}}}$$

$$F_C(E) = e^{\frac{E_F-E}{K_B T}} \rightarrow (7)$$

Also the density of electrons

$$Z_C(E) d(E) = \frac{\pi}{2} \left[\frac{8m_e^*}{h^2} \right]^{\frac{3}{2}} (E)^{\frac{1}{2}} dE \rightarrow (8)$$

Here $E > E_C$. Since E_C is the minimum energy state in CB. Hence equation (8) becomes

$$Z_C(E) d(E) = \frac{\pi}{2} \left[\frac{8m_e^*}{h^2} \right]^{\frac{3}{2}} (E - E_C)^{\frac{1}{2}} dE \rightarrow (9)$$

Substituting equations (7) & (9) in equation (5) we get

$$n = \int_{E_C}^{\infty} \frac{\pi}{2} \left[\frac{8m_e^*}{h^2} \right]^{\frac{3}{2}} (E - E_C)^{\frac{1}{2}} e^{\frac{E_F-E}{K_B T}} dE$$

$$n = \frac{\pi}{2} \left[\frac{8m_e^*}{h^2} \right]^{\frac{3}{2}} \int_{E_C}^{\infty} (E - E_C)^{\frac{1}{2}} e^{\frac{E_F-E}{K_B T}} dE \rightarrow (10)$$

Let $\varepsilon = E - E_C$

$d\varepsilon = dE$ { E_C is constant } . The limits are $\varepsilon = 0$ to $\varepsilon = \infty$

Hence equation (10) can be written as

$$n = \frac{\pi}{2} \left[\frac{8m_e^*}{h^2} \right]^{\frac{3}{2}} \int_{\varepsilon=0}^{\infty} (\varepsilon)^{\frac{1}{2}} e^{\frac{E_F-(\varepsilon+E_C)}{K_B T}} d\varepsilon$$

$$n = \frac{\pi}{2} \left[\frac{8m_e^*}{h^2} \right]^{\frac{3}{2}} e^{\frac{(E_F-E_C)}{K_B T}} \int_{\varepsilon=0}^{\infty} (\varepsilon)^{\frac{1}{2}} e^{\frac{-\varepsilon}{K_B T}} d\varepsilon \rightarrow (11)$$

In equation (11) But $\int_{\varepsilon=0}^{\infty} (\varepsilon)^{\frac{1}{2}} e^{\frac{-\varepsilon}{K_B T}} d\varepsilon = \frac{\sqrt{\pi}}{2} (k_B T)^{\frac{3}{2}} \rightarrow (12)$

Substituting (12) in (11) we get

$$n = \frac{\pi}{2} \left[\frac{8m_e^*}{h^2} \right]^{\frac{3}{2}} e^{\frac{(E_F-E_C)}{K_B T}} \frac{\sqrt{\pi}}{2} (k_B T)^{\frac{3}{2}}$$

$$n = \frac{1}{4} \left[\frac{8\pi m_e^* K_B T}{h^2} \right]^{\frac{3}{2}} e^{\frac{(E_F-E_C)}{K_B T}}$$

$$n = \frac{8}{4} \left[\frac{2\pi m_e^* K_B T}{h^2} \right]^{\frac{3}{2}} e^{\frac{(E_F-E_C)}{K_B T}}$$

$$n = 2 \left[\frac{2\pi m_e^* K_B T}{h^2} \right]^{\frac{3}{2}} e^{\frac{-(E_C-E_F)}{K_B T}} \rightarrow (13)$$

{ Here $N_C = 2 \left[\frac{2\pi m_e^* K_B T}{h^2} \right]^{\frac{3}{2}}$ } Therefore $n = N_C e^{\frac{-(E_C-E_F)}{K_B T}}$

Hole concentration in the valance band of intrinsic semiconductor(p)

Definition: The number of holes per unit volume of the valance band of a given intrinsic semiconductor is called hole concentration, represented by 'p'.

Derivation: Let the number of holes per unit volume of the semiconductor having energies E , $E + dE$ in VB is represented by $p(E) dE$. It is obtained by multiplying the density of energy states $Z_V(E) d(E)$ [No. of energy states per unit volume] and Fermi - Dirac distribution function for the Probability of occupation of holes $F_h(E)$.

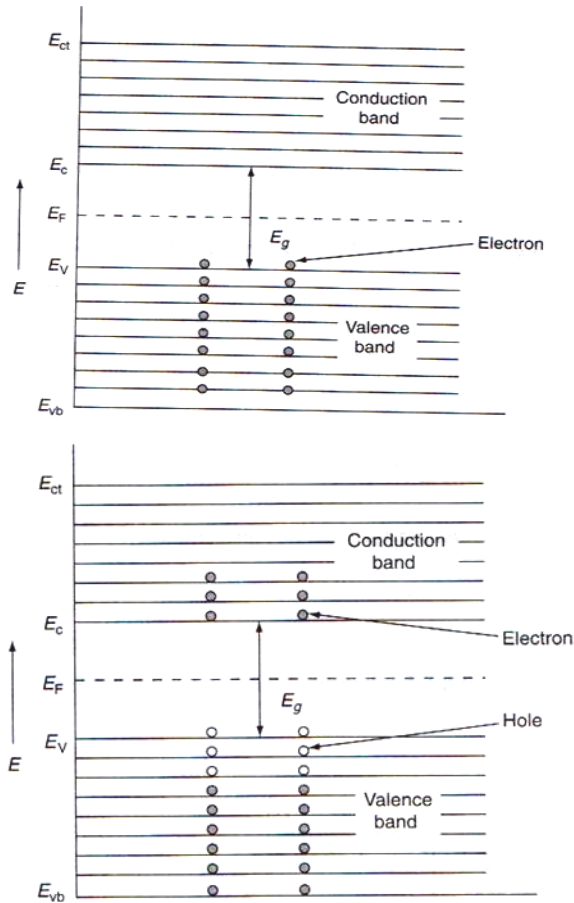

(a) Energy band diagram of silicon at $T = 0K$
 (b) Energy band diagram of silicon at $T > 0K$

Therefore $p(E) dE = [Z_v(E) d(E)] [F_h(E)] \rightarrow (1)$

Where $Z_v(E) d(E) =$ Density of energy states.

$F_h(E) =$ Hole probability given by Fermi – Dirac function

The total no. of holes in VB per unit volume between the energies E_{vb} to E_v is given by integrating equation (1) with limits E_{vb} to E_v

$$p = \int_{E_{vb}}^{E_v} p(E) dE \rightarrow (2)$$

But equation (2) can be written as

$$p = \int_{E_{vb}}^{-\infty} p(E) dE + \int_{-\infty}^{E_v} p(E) dE \rightarrow (3)$$

$$p = - \int_{-\infty}^{E_{vb}} p(E) dE + \int_{-\infty}^{E_v} p(E) dE \rightarrow (4)$$

In equation (4) the first term vanishes (disappears).

Since, below E_{vb} holes do not present. Hence equation (4) becomes

$$p = \int_{-\infty}^{E_v} p(E) dE$$

$$p = \int_{-\infty}^{E_v} [Z_v(E) dE] \times F_h(E) \rightarrow (5)$$

{ Since from equation (1) }

But $[F_h(E)]$ is Fermi – Dirac distribution function;

$$F_h(E) = 1 - F_C(E) \rightarrow (6)$$

$$= 1 - \frac{1}{1 + e^{\frac{E-E_F}{K_B T}}}$$

Simplifying; $F_h(E) = \frac{e^{\frac{E-E_F}{K_B T}}}{1 + e^{\frac{E-E_F}{K_B T}}}$

Divide by $e^{\frac{E-E_F}{K_B T}}$ we get

$$F_h(E) = \frac{1}{1 + \frac{1}{e^{\frac{E-E_F}{K_B T}}}}$$

$$F_h(E) = \frac{1}{1 + e^{\frac{E_F-E}{K_B T}}} \rightarrow (6)$$

Here $E_F > E$, i. e. $e^{\frac{E_F-E}{K_B T}} \gg 1$

Hence '1' can be neglected in equation (6)

$$F_h(E) = \frac{1}{e^{\frac{E_F-E}{K_B T}}}$$

$$F_h(E) = e^{\frac{E-E_F}{K_B T}} \rightarrow (7)$$

Also the density of holes

$$Z_v(E) d(E) = \frac{\pi}{2} \left[\frac{8m_p^*}{h^2} \right]^{\frac{3}{2}} (E)^{\frac{1}{2}} dE \rightarrow (8)$$

Here $E < E_v$. Since E_v is the maximum energy state in VB. Hence equation (8) becomes

$$Z_v(E) d(E) = \frac{\pi}{2} \left[\frac{8m_p^*}{h^2} \right]^{\frac{3}{2}} (E_v - E)^{\frac{1}{2}} dE \rightarrow (9)$$

Substituting equations (7) & (9) in equation (5) we get

$$p = \int_{-\infty}^{E_v} \frac{\pi}{2} \left[\frac{8m_p^*}{h^2} \right]^{\frac{3}{2}} (E_v - E)^{\frac{1}{2}} e^{\frac{E-E_F}{K_B T}} dE$$

$$p = \frac{\pi}{2} \left[\frac{8m_p^*}{h^2} \right]^{\frac{3}{2}} \int_{-\infty}^{E_v} (E_v - E)^{\frac{1}{2}} e^{\frac{E-E_F}{K_B T}} dE \rightarrow (10)$$

Let $\varepsilon = E_v - E$

$d\varepsilon = -dE$ { E_v is constant } . The limits are $\varepsilon = \infty$ to $\varepsilon = 0$

Hence equation (10) can be written as

$$p = \frac{\pi}{2} \left[\frac{8m_p^*}{h^2} \right]^{\frac{3}{2}} \int_{\varepsilon=\infty}^0 (\varepsilon)^{\frac{1}{2}} e^{\frac{(E_v-\varepsilon)-E_F}{K_B T}} d\varepsilon$$

$$p = \frac{\pi}{2} \left[\frac{8m_p^*}{h^2} \right]^{\frac{3}{2}} e^{\frac{(E_v-E_F)}{K_B T}} \int_{\varepsilon=0}^{\infty} (\varepsilon)^{\frac{1}{2}} e^{\frac{-\varepsilon}{K_B T}} d\varepsilon \rightarrow (11)$$

In equation (11) But $\int_{\varepsilon=0}^{\infty} (\varepsilon)^{\frac{1}{2}} e^{\frac{-\varepsilon}{K_B T}} d\varepsilon = \frac{\sqrt{\pi}}{2} (k_B T)^{\frac{3}{2}} \rightarrow (12)$

Substituting (12) in (11) we get

$$p = \frac{\pi}{2} \left[\frac{8m_p^*}{h^2} \right]^{\frac{3}{2}} e^{\frac{(E_v-E_F)}{K_B T}} \frac{\sqrt{\pi}}{2} (k_B T)^{\frac{3}{2}}$$

$$p = \frac{1}{4} \left[\frac{8\pi m_p^* K_B T}{h^2} \right]^{\frac{3}{2}} e^{\frac{(E_v-E_F)}{K_B T}}$$

$$p = \frac{8}{4} \left[\frac{2\pi m_p^* K_B T}{h^2} \right]^{\frac{3}{2}} e^{\frac{(E_v-E_F)}{K_B T}}$$

$$p = 2 \left[\frac{2\pi m_p^* K_B T}{h^2} \right]^{\frac{3}{2}} e^{\frac{-(E_F - E_V)}{K_B T}} \rightarrow (13)$$

$$\{ \text{Here } N_V = 2 \left[\frac{2\pi m_p^* K_B T}{h^2} \right]^{\frac{3}{2}} \}$$

$$p = N_V e^{\frac{-(E_F - E_V)}{K_B T}}$$

Fermi energy level in intrinsic semiconductor

At temperature T k , the electron concentration 'n' is equal to hole concentration 'p' in intrinsic semiconductor.

i.e.

$$n = p$$

$$2 \left[\frac{2\pi m_e^* K_B T}{h^2} \right]^{\frac{3}{2}} e^{\frac{-(E_C - E_F)}{K_B T}} = 2 \left[\frac{2\pi m_p^* K_B T}{h^2} \right]^{\frac{3}{2}} e^{\frac{-(E_F - E_V)}{K_B T}}$$

On simplifying we get

$$\begin{aligned} (m_e^*)^{\frac{3}{2}} e^{\frac{-(E_C - E_F)}{K_B T}} &= (m_p^*)^{\frac{3}{2}} e^{\frac{-(E_F - E_V)}{K_B T}} \\ \frac{e^{\frac{-(E_C - E_F)}{K_B T}}}{e^{\frac{-(E_F - E_V)}{K_B T}}} &= \frac{(m_p^*)^{\frac{3}{2}}}{(m_e^*)^{\frac{3}{2}}} \end{aligned}$$

$$e^{\frac{E_C + E_F + E_F - E_V}{K_B T}} = \left[\frac{m_p^*}{m_e^*} \right]^{\frac{3}{2}}$$

$$e^{\frac{2E_F}{K_B T} + \frac{(E_C - E_V)}{K_B T}} = \left[\frac{m_p^*}{m_e^*} \right]^{\frac{3}{2}}$$

Taking logarithms on both sides we get

$$\frac{2E_F}{K_B T} + \frac{(E_C - E_V)}{K_B T} = \frac{3}{2} \ln \left[\frac{m_p^*}{m_e^*} \right]$$

$$\frac{2E_F}{K_B T} = \frac{(E_C - E_V)}{K_B T} + \frac{3}{2} \ln \left[\frac{m_p^*}{m_e^*} \right]$$

$$E_F = \frac{(E_C + E_V)}{2} + \frac{3}{4} K_B T \ln \left[\frac{m_p^*}{m_e^*} \right] \quad \{ \text{At } T > 0K \}$$

$$\text{Let } T = 0K \quad E_F = \frac{(E_C + E_V)}{2}$$

This means E_F lies in the middle between $(E_C \& E_V)$ of the energy gap ' E_g '

As the temperature increases the electrons move from VB to CB. Also the Fermi level slightly rises upwards towards CB. Hence $E_F = \frac{(E_C + E_V)}{2} + \frac{3}{4} K_B T \ln \left[\frac{m_p^*}{m_e^*} \right]$. It is shown in the figure 6 below.

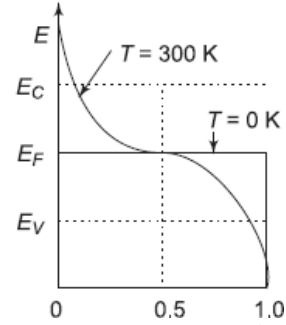
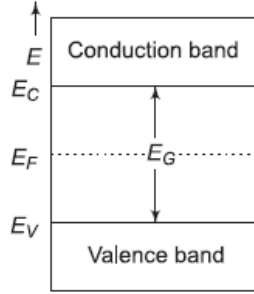

(a) Fermi level E_F at $T = 0K$ (b) Upward shift of E_F near E_C at $T > 0k$

Intrinsic carrier concentration (n_i)

Definition: The no. of free electrons and holes per unit volume of the intrinsic semiconductor is called intrinsic carrier concentration (n_i) remains constant.

i .e. $n = p = n_i$
 $n p = (n_i) (n_i)$

$$n_i^2 = (n p) \rightarrow (1)$$

$$n_i = (np)^{\frac{1}{2}} \rightarrow (2)$$

Consider equation (1) $n_i^2 = (n p)$

$$n_i^2 = 2 \left[\frac{2\pi m_e^* K_B T}{h^2} \right]^{\frac{3}{2}} e^{\frac{-(E_C - E_F)}{K_B T}} \times 2 \left[\frac{2\pi m_p^* K_B T}{h^2} \right]^{\frac{3}{2}} e^{\frac{-(E_F - E_V)}{K_B T}}$$

$$= 4 \left[\frac{2\pi K_B T}{h^2} \right]^3 (m_e^* m_p^*)^{\frac{3}{2}} e^{\frac{-E_C + E_F - E_F + E_V}{K_B T}}$$

$$n_i^2 = 4 \left[\frac{2\pi K_B T}{h^2} \right]^3 (m_e^* m_p^*)^{\frac{3}{2}} e^{\frac{-E_g}{K_B T}} \quad \{\text{Since } E_C - E_V = E_g\}$$

$$n_i = 2 \left[\frac{2\pi K_B T}{h^2} \right]^{\frac{3}{2}} (m_e^* m_p^*)^{\frac{3}{4}} e^{\frac{-E_g}{2K_B T}}$$

If $m_e^* = m_p^* = m^*$, the above equation becomes

$$n_i = 2 \left[\frac{2\pi K_B T}{h^2} \right]^{\frac{3}{2}} (m^*)^{\frac{3}{2}} e^{\frac{-E_g}{2K_B T}}$$

$$n_i = 2 \left[\frac{2\pi m^* K_B T}{h^2} \right]^{\frac{3}{2}} e^{\frac{-E_g}{2K_B T}}$$

Let $2 \left[\frac{2\pi m^* K_B T}{h^2} \right]^{\frac{3}{2}} = C.$

Then $n_i = C [T]^{\frac{3}{2}} e^{\frac{-E_g}{2K_B T}}$

Extrinsic (or) Impure semiconductor

Introduction: The conductivity of an intrinsic semiconductor can be increased by adding small amounts of impurity atoms, such as IIIrd or Vth_{group} atoms. The conductivity of silica is increased by 1000 times on adding 10 parts of boron per million part of silicon. The process of adding impurities is called doping and the impurity added is called dopant.

N – Type semiconductor

In a pure (intrinsic) semiconductor, when pentavalent an impurity like Phosphorous atom consisting of five valence electrons is doped, and then concentration of electrons increases than holes. Hence the given semiconductor formed is called N – type semiconductor. This is shown in the figure 7a below. By adding donor impurities, the free electrons generated or donated, form an energy level called as “Donor energy level” i.e. E_D is shown in the figure below.

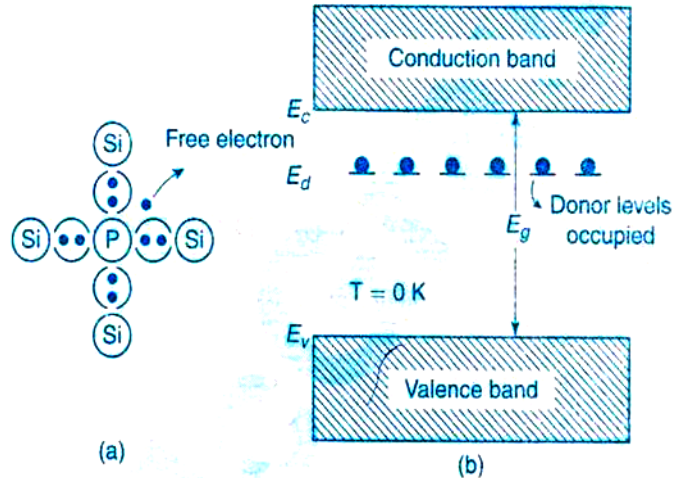

(a) Representation of n- type silicon at $T = 0K$ (b) Energy band diagram at $T = 0K$

In the figure (b) E_F is Fermi energy level is in between E_C & E_D at $T = 0K$.

Hence $E_F = \frac{E_C + E_D}{2}$. The donor level ' E_D ' is near to E_F consisting of free electrons. But CB is empty.

Variation of Fermi level E_F with respect to temperature in N -type

As temperature increases the electrons in the Donor level ' E_D ' moves into CB leaving holes. Also The Fermi level slightly shifts upwards towards CB. If further increase of temperature is done, the hole concentration also increases with respect to electron concentration. Hence it reaches again the concentration of $n = p$ i.e. an intrinsic semiconductor. At last the Fermi level drops in the middle of the energy gap (or) Forbidden band gap, indicating a pure semiconductor that is towards ' E_i '. This happens only for very high temperatures as shown in the figure 8 below.

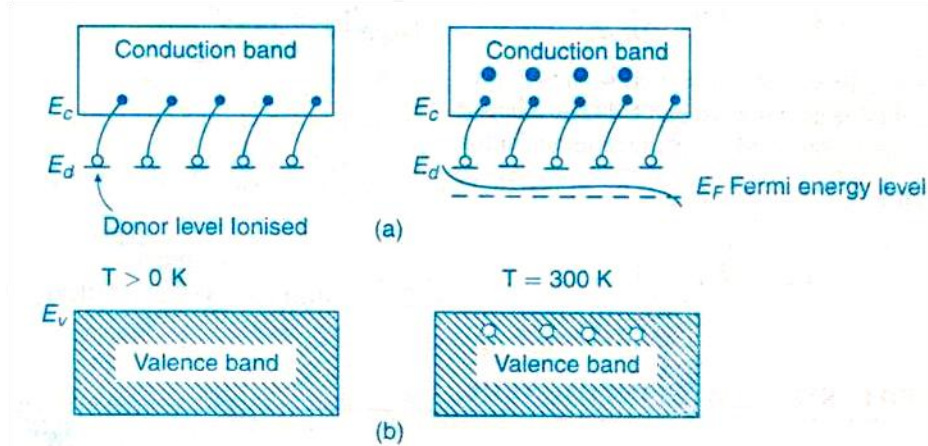
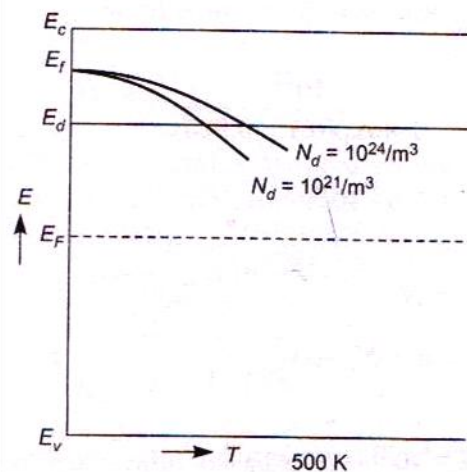

Fig.8 Variation of Fermi level wrt temperature in n- type semiconductor

Variation of E_F with respect to donor concentration

As the donor concentration increases the Fermi level decreases (lowers) as in case of intrinsic semiconductor ' E_i '. This is shown in the figure below



Variation of Fermi level with temperature for different donor concentrations in an n-type semiconductor

Carrier concentration in N – type semiconductor & Density of electrons in CB

Let N_D is the donor concentration (no. of donor atoms per unit volume). Let it be written as

$$\begin{aligned} \text{Or written as} &= N_D \exp \left[\frac{-(E_F - E_D)}{K_B T} \right] \\ &= N_D e^{\frac{-(E_F - E_D)}{K_B T}} \rightarrow (1) \end{aligned}$$

The density of electrons in CB in pure semiconductor is given by

$$= 2 \left[\frac{2\pi m_e^* K_B T}{h^2} \right]^{\frac{3}{2}} e^{\frac{-(E_C - E_F)}{K_B T}} \rightarrow (2)$$

At very low temperatures the no. of electrons in CB must be equal to the no. of donor atoms per unit volume. Hence equating equations (1) & (2) we get

$$2\left[\frac{2\pi m_e^* K_B T}{h^2}\right]^{\frac{3}{2}} e^{\frac{-(E_C - E_F)}{K_B T}} = N_D e^{\frac{-(E_F - E_D)}{K_B T}}$$

$$e^{\frac{-(E_C + E_F)}{K_B T}} = \frac{N_D}{2\left[\frac{2\pi m_e^* K_B T}{h^2}\right]^{\frac{3}{2}}}$$

$$e^{\frac{-(E_C + E_F + E_F - E_D)}{K_B T}} = \frac{N_D}{2\left[\frac{2\pi m_e^* K_B T}{h^2}\right]^{\frac{3}{2}}}$$

$$e^{\frac{2E_F - (E_C + E_D)}{K_B T}} = \frac{N_D}{2\left[\frac{2\pi m_e^* K_B T}{h^2}\right]^{\frac{3}{2}}}$$

Taking logarithms on both sides we get

$$\frac{2E_F - (E_C + E_D)}{K_B T} = \log\left[\frac{N_D}{2\left[\frac{2\pi m_e^* K_B T}{h^2}\right]^{\frac{3}{2}}}\right]$$

$$2E_F - (E_C + E_D) = K_B T \log\left[\frac{N_D}{2\left[\frac{2\pi m_e^* K_B T}{h^2}\right]^{\frac{3}{2}}}\right]$$

$$E_F = \frac{(E_C + E_D)}{2} + \frac{K_B T}{2} \log\left[\frac{N_D}{2\left[\frac{2\pi m_e^* K_B T}{h^2}\right]^{\frac{3}{2}}}\right] \quad \{\text{At } T > 0\text{K}\} \rightarrow (3)$$

Case I: At $T = 0\text{K}$

$$E_F = \frac{(E_C + E_D)}{2}. \text{ That is } E_F \text{ lies between } E_C \text{ \& } E_D$$

Case II: At $T > 0\text{K}$. As temperature increases the Fermi level slightly shifts upwards towards CB, hence

$$E_F = \frac{(E_C + E_D)}{2} + \frac{K_B T}{2} \log\left[\frac{N_D}{2\left[\frac{2\pi m_e^* K_B T}{h^2}\right]^{\frac{3}{2}}}\right]$$

Density of electrons in CB in extrinsic semiconductor:

Here consider equation (2). That is

$$= 2\left[\frac{2\pi m_e^* K_B T}{h^2}\right]^{\frac{3}{2}} e^{\frac{-(E_C - E_F)}{K_B T}}$$

OR

$$= 2\left[\frac{2\pi m_e^* K_B T}{h^2}\right]^{\frac{3}{2}} e^{\frac{(E_F - E_C)}{K_B T}}$$

Substitute the value of E_F from equation (3) in equation (2), it becomes $n_{(\text{Extrinsic } N\text{-type})}$

$$n_{(\text{Extrinsic } N\text{-type})} = 2\left[\frac{2\pi m_e^* K_B T}{h^2}\right]^{\frac{3}{2}} \exp\left[\frac{\frac{(E_C + E_D)}{2} + \frac{K_B T}{2} \log\left[\frac{N_D}{2\left[\frac{2\pi m_e^* K_B T}{h^2}\right]^{\frac{3}{2}}}\right] - E_C}{K_B T}\right]$$

On simplifying

We know that $\exp(a + b) = \exp(a) \times \exp(b)$

Also $\exp(\log x) = x$

$$= 2\left[\frac{2\pi m_e^* K_B T}{h^2}\right]^{\frac{3}{2}} \exp\left[\frac{(E_D - E_C)}{2K_B T}\right] \left\{ \frac{(N_D)^{\frac{1}{2}}}{(2)^{\frac{1}{2}} \left[\frac{2\pi m_e^* K_B T}{h^2}\right]^{\frac{3}{4}}}\right\}$$

$$n_{(\text{Extrinsic } N\text{-type})} = (2N_D)^{\frac{1}{2}} \left[\frac{2\pi m_e^* K_B T}{h^2}\right]^{\frac{3}{4}} \exp\left[\frac{-(E_C - E_D)}{2K_B T}\right]$$

OR

$$n_{(Extrinsic\ N\ -type)} = (2N_D)^{\frac{1}{2}} \left[\frac{2\pi m_e^* K_B T}{h^2} \right]^{\frac{3}{4}} e^{\left[\frac{-(E_C - E_D)}{2K_B T} \right]}$$

P- type semiconductor

P – Type semiconductor is formed by doping with trivalent impurity atoms (acceptor) like IIIrd group atoms i.e. Aluminum, Gallium, and Indium etc to a pure semiconductor like Ge or Si. As the acceptor trivalent atoms has only three valence electrons & Germanium , Silicon has four valence electrons; holes or vacancy is created for each acceptor dopant atom. Hence holes are majority and electrons are minority. It is shown in the figure a below. Also an acceptor energy level ‘E_A’ is formed near VB consisting of holes, as shown in the figure below.

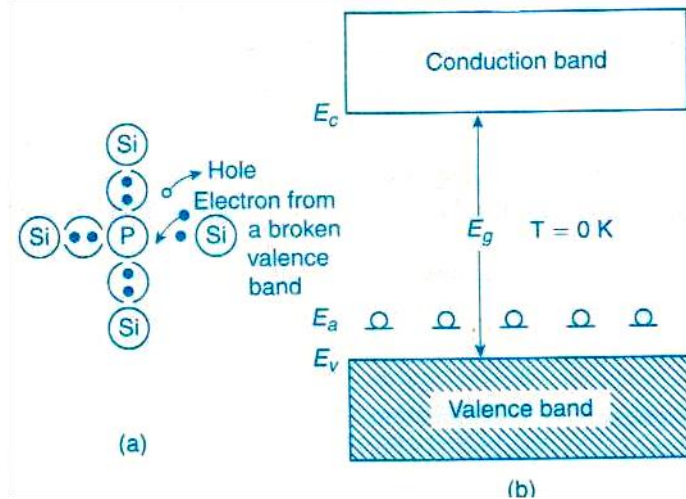

(a) Representation of p- type silicon at T = 0K (b) Energy band diagram at T = 0K

As temperature increases (T > 0K) the electrons in VB which are in covalent bonds break the bonds become free and move from VB to acceptor energy level E_A.

Variation of Fermi level E_F with respect to temperature in P- type semiconductor

As temperature increases the Fermi level E_F slightly drops towards VB. For further increase of high temperatures the electron concentration also increases with respect to hole concentration. Hence a condition is reached such that ‘n = p’ i.e. it becomes an intrinsic or pure semiconductor. Hence the Fermi level increases and reaches to intrinsic level E_i as in case of pure semiconductor. This is shown in the figure below

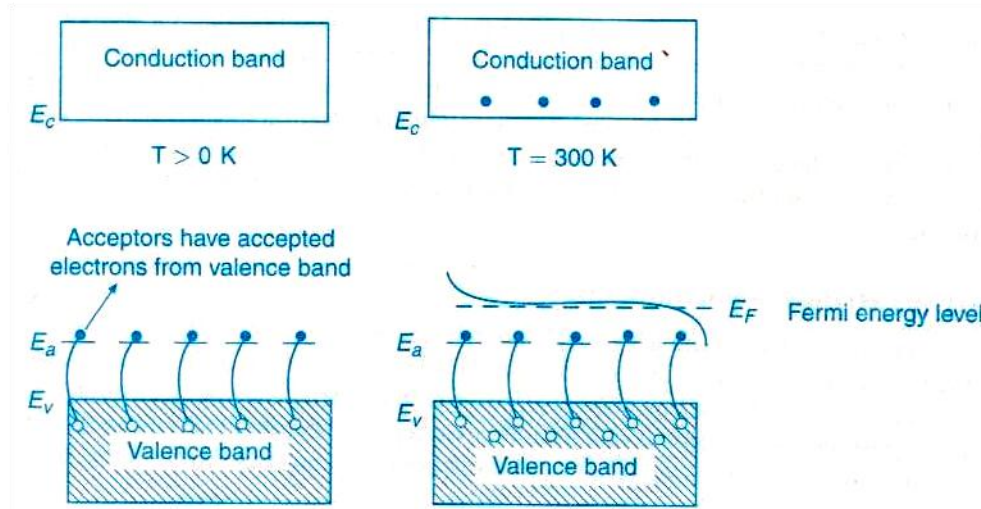

Variation of Fermi level wrt temperature in p-type

Variation of Fermi level with respect to acceptor concentration:

Also as the acceptor concentration increases we find that Fermi level E_F reaches (increases) towards intrinsic level E_i as in case of pure or intrinsic semiconductor. This is shown in the figure below.

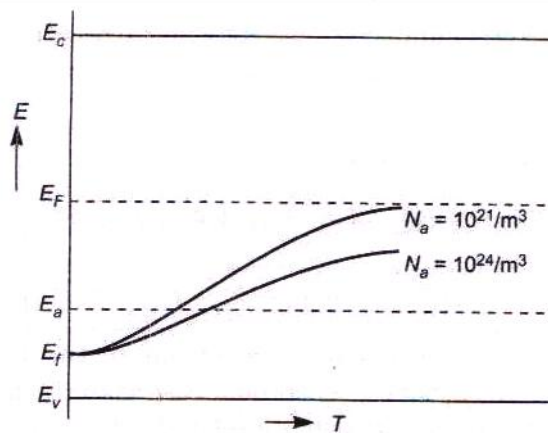

Variation of Fermi level with temperature for different acceptor concentrations in a p-type

Carrier concentration of P- type semiconductor & Density of holes in VB

Let N_A is the acceptor concentration (no. of acceptor atoms per unit volume). Let it be written as

$$= N_A \exp \left[\frac{-(E_A - E_F)}{K_B T} \right]$$

Or written as

$$= N_A e^{\frac{(E_F - E_A)}{K_B T}} \rightarrow (1)$$

The density of holes in VB in pure semiconductor is given by

$$= 2 \left[\frac{2\pi m_p^* K_B T}{h^2} \right]^{\frac{3}{2}} e^{\frac{-(E_F - E_V)}{K_B T}} \rightarrow (2)$$

At very low temperatures the no. of holes in VB must be equal to the no. of acceptor atoms per unit volume. Hence equating equations (1) & (2) we get

$$2\left[\frac{2\pi m_p^* K_B T}{h^2}\right]^{\frac{3}{2}} e^{\frac{(-E_F+E_V)}{K_B T}} = N_A e^{\frac{(E_F-E_A)}{K_B T}}$$

$$\frac{e^{\frac{(-E_F+E_V)}{K_B T}}}{e^{\frac{(E_F-E_A)}{K_B T}}} = \frac{N_A}{2\left[\frac{2\pi m_p^* K_B T}{h^2}\right]^{\frac{3}{2}}}$$

$$e^{\frac{-E_F+E_V-E_F+E_A}{K_B T}} = \frac{N_A}{2\left[\frac{2\pi m_p^* K_B T}{h^2}\right]^{\frac{3}{2}}}$$

$$e^{\frac{-2E_F+(E_V+E_A)}{K_B T}} = \frac{N_A}{2\left[\frac{2\pi m_p^* K_B T}{h^2}\right]^{\frac{3}{2}}}$$

Taking logarithms on both sides we get

$$\frac{-2E_F+(E_V+E_A)}{K_B T} = \log\left[\frac{N_A}{2\left[\frac{2\pi m_p^* K_B T}{h^2}\right]^{\frac{3}{2}}}\right]$$

$$-2E_F+(E_V+E_A) = K_B T \log\left[\frac{N_A}{2\left[\frac{2\pi m_p^* K_B T}{h^2}\right]^{\frac{3}{2}}}\right]$$

$$E_F = \frac{(E_V+E_A)}{2} - \frac{K_B T}{2} \log\left[\frac{N_A}{2\left[\frac{2\pi m_p^* K_B T}{h^2}\right]^{\frac{3}{2}}}\right] \quad \{\text{At } T > 0K\} \rightarrow (3)$$

Case I: At T= 0K

$$E_F = \frac{(E_V+E_A)}{2}. \text{ That is } E_F \text{ lies between } E_V \text{ \& } E_A$$

Case II: At T>0K. As temperature increases the Fermi level slightly drops towards VB, hence

$$E_F = \frac{(E_V+E_A)}{2} - \frac{K_B T}{2} \log\left[\frac{N_A}{2\left[\frac{2\pi m_p^* K_B T}{h^2}\right]^{\frac{3}{2}}}\right]$$

Density of electrons in CB in extrinsic semiconductor

Here consider equation (2). That is

$$= 2\left[\frac{2\pi m_p^* K_B T}{h^2}\right]^{\frac{3}{2}} e^{\frac{-(E_F-E_V)}{K_B T}}$$

OR

$$= 2\left[\frac{2\pi m_p^* K_B T}{h^2}\right]^{\frac{3}{2}} e^{\frac{(-E_F+E_V)}{K_B T}}$$

Substitute the value of E_F from equation (3) in equation (2), it becomes $n_{(ExtrinsicP -type)}$

$$n_{(ExtrinsicP -type)} = 2\left[\frac{2\pi m_p^* K_B T}{h^2}\right]^{\frac{3}{2}} \exp\left\{\frac{\left[\frac{-(E_V+E_A)}{2} + \frac{K_B T}{2} \log\left[\frac{N_A}{2\left[\frac{2\pi m_p^* K_B T}{h^2}\right]^{\frac{3}{2}}}\right] + E_V\right]}{K_B T}\right\}$$

On simplifying

We know that $\exp(a+b) = \exp(a) \times \exp(b)$

Also $\exp(\log x) = x$

$$= 2\left[\frac{2\pi m_p^* K_B T}{h^2}\right]^{\frac{3}{2}} \exp\left[\frac{(E_V-E_A)}{2K_B T}\right] \left\{\frac{(N_A)^{\frac{1}{2}}}{(2)^{\frac{1}{2}} \left[\frac{2\pi m_p^* K_B T}{h^2}\right]^{\frac{3}{4}}}\right\}$$

$$n_{(\text{Extrinsic } P\text{-type})} = (2N_A)^{\frac{1}{2}} \left[\frac{2\pi m_p^* K_B T}{h^2} \right]^{\frac{3}{4}} \exp \left[\frac{-(E_A - E_V)}{2K_B T} \right]$$

OR

$$n_{(\text{Extrinsic } P\text{-type})} = (2N_A)^{\frac{1}{2}} \left[\frac{2\pi m_p^* K_B T}{h^2} \right]^{\frac{3}{4}} e^{\left[\frac{-(E_A - E_V)}{2K_B T} \right]}$$

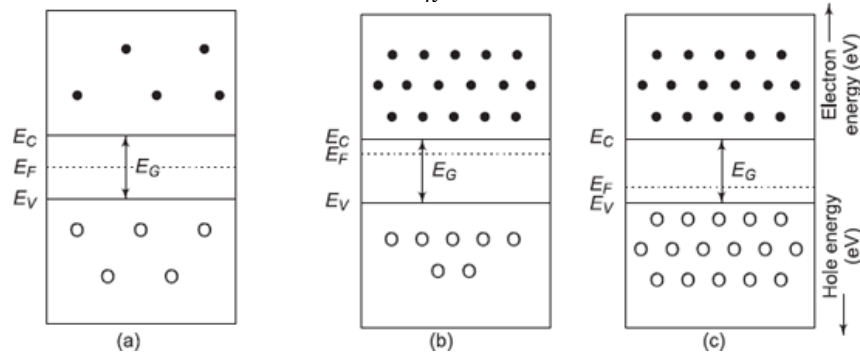

Energy band diagrams of (a) Intrinsic semiconductor (b) N- type & (c) P- type semiconductors

Hall Effect

Determination of Hall coefficient R_H , Hall voltage V_H & Applications of Hall Effect

Definition:

If a piece of semiconductor carrying a current 'I' is placed in a transverse or perpendicular magnetic field, then an Electric field ' E_H ' is generated in perpendicular to both 'I' and 'B'. Hence production of Hall electric field ' E_H ' and generation of Hall voltage V_H by applying current 'I' & 'B' in perpendicular directions is called Hall Effect.

Derivation of R_H , V_H , & E_H :

Assume an N – type semiconductor. Let 'I' be the current passed along X- axis. Let 'B' the magnetic field applied along 'Z' axis. Due to current 'I', due to the flow of electrons, the force acting on electrons is in opposite direction to the direction of conventional current.

Due to the magnetic field 'B' there is a down ward force act on each electron given by Bev . This makes the electrons deviated in a down ward direction along Z – axis. This causes a negative charge to accumulate on the bottom face.

Hence $F_B = Bev$

Where 'e' = charge of electron, v = velocity of electron

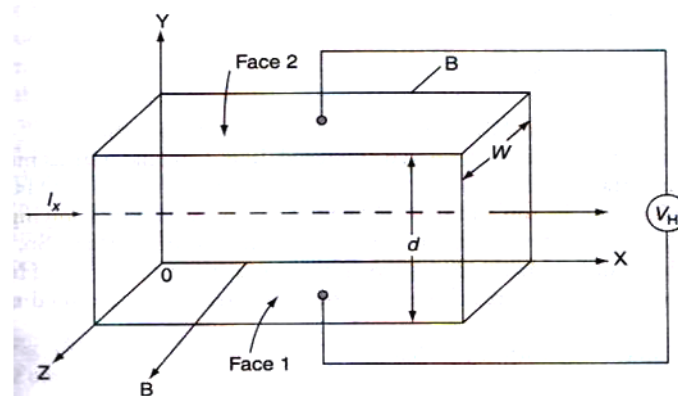

A semiconductor applied to current and magnetic field perpendicularly in Hall Effect

A potential difference is formed from top to bottom of the specimen. The potential difference causes a field E_H to flow along negative Y- axis. Due to E_H along negative Y- direction a force of eE_H acts in upward direction along positive Y- axis.

Hence $F_E = e E_H$

Under equilibrium condition

Upward force due to $E_H =$ Downward force due to B.

$$\begin{aligned} F_B &= F_E \\ e E_H &= Bev \\ v &= \frac{E_H}{B} \rightarrow (1) \end{aligned}$$

If J is the current density then $J = nev$

$$v = \frac{J}{ne} \rightarrow (2)$$

Equating (1) & (2) we get

$$\begin{aligned} \frac{E_H}{B} &= \frac{J}{ne} \\ E_H &= \frac{JB}{ne} \\ E_H &= \left[\frac{-1}{ne} \right] B J \end{aligned}$$

Let Hall coefficient

$$\begin{aligned} R_H &= \frac{-1}{ne} \quad \text{for electrons} \\ R_H &= \frac{-1}{pe} \quad \text{for holes} \end{aligned}$$

$$\text{Hence } E_H = R_H B J \rightarrow (4)$$

$$R_H = \frac{E_H}{B J} \rightarrow (5)$$

Where n= electron density, P = hole density, E_H = Hall electric field, R_H = Hall coefficient
B = magnetic field, J = current density

Experimental determination of R_H

Consider equation (5)

$$R_H = \frac{E_H}{B J}$$

Let V_H is the Hall voltage across the sample of thickness 't'

Generally

$$V = Ed$$

In Hall effect

$$V_H = E_H \times t$$

$$E_H = \frac{V_H}{t} \rightarrow (6)$$

If 'b' is the width of the sample semiconductor, Area 'A', thickness 't'

Area = breadth \times thickness

$$A = b \times t$$

We know that current density

$$\begin{aligned} J &= \frac{I}{A} \\ J &= \frac{I}{bt} \rightarrow (7) \end{aligned}$$

Substituting equations (6) & (7) in (5) we get

$$R_H = \frac{\left[\frac{V_H}{t} \right]}{B \left[\frac{I}{bt} \right]}$$

Hall coefficient $R_H = \frac{V_H \times b}{B \times I} \rightarrow (8)$

Where V_H = Hall voltage, b = breadth of a semiconductor, B = magnetic field

I = current due to flow of electron

$$V_H = \frac{R_H B I}{b} \rightarrow (9)$$

Applications of Hall Effect

1. For determination of type of given semiconductor.

For N-type, Hall coefficient R_H = negative; For P-type, Hall coefficient R_H = Positive

2. To determine carrier concentration 'n' and 'p' ; that is $n = p = \frac{1}{R_H e}$
3. Determination of mobility of charge carriers (μ)

$$\sigma = ne\mu$$

$$\mu = \left[\frac{1}{ne} \right] \sigma = R_H \sigma$$

$$\mu = \left[\frac{V_H b}{BI} \right] \sigma, \quad \text{Where } \sigma = \text{electrical conductivity}$$

4. For measurement of magnetic flux density 'B' & Hall voltage.
5. To determine the sign of charge carriers, whether the conductivity is due to electrons or holes.

MODULE-III LASERS AND FIBER OPTICS

Introduction

LASER stands for light amplification by stimulated emission of radiation. It is different from conventional light (such as tube light or electric bulb), there is no coordination among different atoms emitting radiation. Laser is a device that emits light (electromagnetic radiation) through a process is called stimulated emission.

Spontaneous and stimulated emission

In lasers, the interaction between matter and light is of three different types. They are: absorption, spontaneous emission and stimulates emission. Let E_1 and E_2 be ground and excited states of an atom. The dot represents an atom. Transition between these states involves absorption and emission of a photon of energy $E_2 - E_1 = h\nu_{12}$. Where 'h' is Planck's constant.

- (a) **Absorption:** As shown in fig8.1(a), if a photon of energy $h\nu_{12}(E_2 - E_1)$ collides with an atom present in the ground state of energy E_1 then the atom completely absorbs the incident photon and makes transition to excited state E_2 .
- (b) **Spontaneous emission:** As shown in fig8. 1. (b), an atom initially present in the excited state makes transition voluntarily on its own. Without any aid of external stimulus or an agency to the ground. State and emits a photon of energy $h\nu_{12} (=E_2 - E_1)$.this is called spontaneous emission. These are incoherent.
- (c) **Stimulated emission:** As shown in fig8.1.(c), a photon having energy $h\nu_{12}(E_2 - E_1)$ impinges on an atom present in the excited state and the atom is stimulated to make transition to the ground state and gives off a photon of energy $h\nu_{12}$. The emitted photon is in phase with the incident photon. These are coherent. This type of emission is known as stimulated emission.

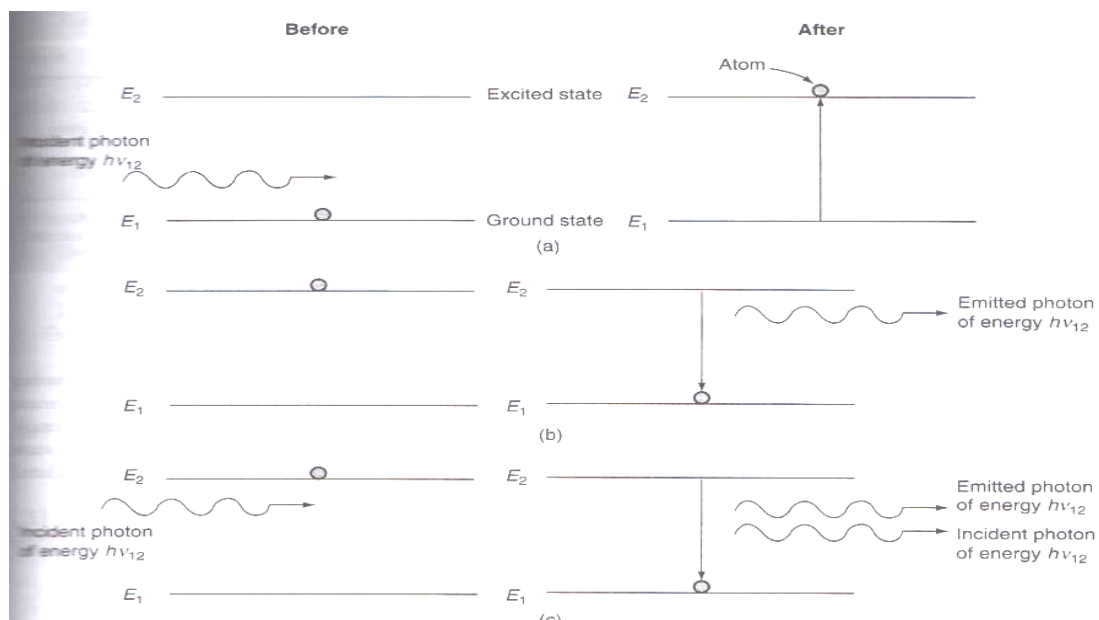

Fig.2.1 (a) Absorption ;(b) Spontaneous emission;(c) Stimulated emission

Differences between Spontaneous emission and stimulated emission of radiation

Spontaneous emission	Stimulated emission
<ol style="list-style-type: none"> 1. Polychromatic radiation 2. Less intensity 3. Less directionality, more angular spread during propagation 4. Spatially and temporally incoherent radiation 5. Spontaneous emission takes place when excited atoms make a transition to lower energy level voluntarily without any external stimulation. 	<ol style="list-style-type: none"> 1. Monochromatic radiation 2. High intensity 3. High directionality, so less angular spread during propagation. 4. Specially and temporally coherent radiation. 5. Stimulated emission takes place when a photon of energy equal to $h\nu_{12}(=E_2-E_1)$ stimulates an excited atom to make transition to lower energy level.

Characteristics of Laser Light

(i).Coherence: Coherence is one of the unique properties of laser light. It arises from the stimulated emission process. Since a common stimulus triggers the emission events which provide the amplified light, the emitted photons are in step and have a definite phase relation to each other. This coherence is described in terms of temporal and spatial coherence.

(ii). Monochromaticity: A laser beam is more or less in single wave length. I.e. the line width of laser beams is extremely narrow. The wavelengths spread of conventional light sources is usually 1 in 10^6 , where as in case of laser light it will be 1 in 10^5 .I.e. if the frequency of radiation is 10^{15} Hz., then the width of line will be 1 Hz. So, laser radiation is said to be highly monochromatic. The degree of non-monochromaticity has been expressed as

$\xi = (d\lambda/\lambda) = dv/v$, where $d\lambda$ or dv is the variation in wavelength or variation in frequency of radiation.

(iii) Directionality: Laser beam is highly directional because laser emits light only in one direction. It can travel very long distances without divergence. The directionality of a laser beam has been expressed in terms of divergence. Suppose r_1 and r_2 are the radii of laser beam at distances D_1 and D_2 from a laser, and then we have.

Then the divergence, $\Delta\theta = (r_2 - r_1) / (D_2 - D_1)$

The divergence for a laser beam is 0.01mille radian where as incase of search light it is 0.5radian.

(iv) High intensity: In a laser beam lot of energy is concentrated in a small region. This concentration of energy exists both spatially and spectrally, hence there is enormous intensity for laser beam. The power range of laser is about 10^{-13} w for gas laser and is about 10^9 w for pulsed solid state laser and the diameter of the laser beam is about 1 mm. then the number of photons coming out from a laser per second per unit area is given by

$$N_1 = P / h\nu\pi r^2 \approx 1022 \text{ to } 1034 \text{ photons/m}^2\text{-sec}$$

By assuming $h\nu = 10^{-19}$ Joule, Power $P = 10^{-3}$ to 10^9 watt $r = 0.5 \times 10^{-3}$ meter

Based on Planck's black body radiation, the number of photons emitted per second per unit area by a body with temperature T is given by

$$N_{\text{th}} = (2h\pi C / \lambda^4) (1/e^{h\nu/kT} - 1) d\lambda \approx 10^{16} \text{ photons/m}^2 \cdot \text{sec}$$

By assuming $T=1000\text{k}$, $\lambda=6000\text{\AA}$

This comparison shows that laser is a highly intensive beam.

Population inversion

Usually in a system the number of atoms (N_1) present in the ground state (E_1) is larger than the number of atoms (N_2) present in the higher energy state. The process of making $N_2 > N_1$ called population inversion. Conditions for population inversion are:

- The system should possess at least a pair of energy levels ($E_2 > E_1$), separated by an energy of equal to the energy of a photon ($h\nu$).
- There should be a continuous supply of energy to the system such that the atoms must be raised continuously to the excited state.

Population inversion can be achieved by a number of ways. Some of them are (i) optical pumping (ii) electrical discharge (iii) inelastic collision of atoms (iv) chemical reaction and (v) direct conversion

Helium-Neon gas laser

Helium-Neon gas laser is a continuous four level gas laser. It consists of a long, narrow cylindrical tube made up of fused quartz. The diameter of the tube will vary from 2 to 8 mm and length will vary from 10 to 100 cm. The tube is filled with helium and neon gases in the ratio of 10:1. The partial pressure of helium gas is 1mm of Hg and neon gas is 0.1mm of Hg so that the pressure of the mixture of gases inside the tube is nearly 1 mm of Hg.

Laser action is due to the neon atoms. Helium is used for selective pumping of neon atoms to upper energy levels. Two electrodes are fixed near the ends of the tube to pass electric discharge through the gas. Two optically plane mirrors are fixed at the two ends of the tube at Brewster angle normal to its axis. One of the mirrors is fully silvered so that nearly 100% reflection takes place and the other is partially silvered so that 1% of the light incident on it will be transmitted. Optical resonator column is formed between these mirrors.

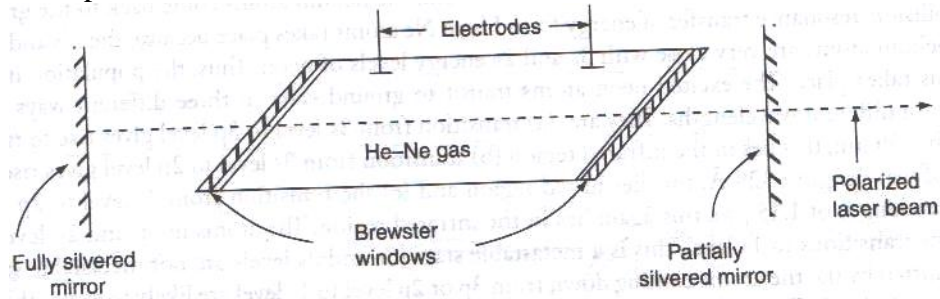

Fig.2.3 Helium-Neon gas laser

Working

When a discharge is passed through the gaseous mixture, electrons are accelerated down the tube. These accelerated electrons collide with the helium atoms and excite them to higher energy levels. The different energy levels of Helium atoms and Neon atoms is shown in fig.2.3 the helium atoms are excited to the levels F_2 and F_3 these levels happen to be meta stable energy states.

Energy levels and hence Helium atoms excited levels spend sufficiently large amount of time before getting de excited. As shown in the fig 2.5(a), some of the excited states of neon can correspond approximately to the same energy of excited levels F_2 and F_3 . Thus, when Helium atoms in level F_2 and F_3 collide with Neon atoms in the ground level E_1 , an energy exchange takes place. This results in the excitation of Neon atoms to the levels E_4 and E_6 and de excitation of Helium atoms to the ground level (F_1). Because of long life times of the atoms in levels F_2 and F_3 , this process of energy transfer has a high probability. Thus the discharge through the gas mixture continuously populates the neon atoms in the excited energy levels E_4 and E_6 . This helps to create a state of population inversion between the levels E_4 (E_6) to the lower energy level (E_3 and E_5). The various transitions $E_6 \rightarrow E_5$, $E_4 \rightarrow E_3$, $E_6 \rightarrow E_3$ leads to the emission of wave lengths $3.39\mu\text{m}$, $1.15\mu\text{m}$ and 6328A° . Specific frequency selection may be obtained by employing mirrors

The excited Neon atoms drop down from the level E_3 to the E_2 by spontaneously emitting a photon around wavelength 6000A° . The pressures of the two gases in the mixture are so chosen that there is an effective transfer of energy from the Helium to the Neon atoms. Since the level E_2 is a meta stable state, there is a finite probability of the excitation of Neon, atoms from E_2 to E_3 leading to population inversion, when a narrow tube is used, the neon atoms in the level E_2 collide with the walls of the tube and get excited to the level E_1 . The transition from E_5 to E_3 may be non radioactive. The typical power outputs of He-Ne laser lie between 1 and 50 mw of continuous wave for inputs of 5-10W.

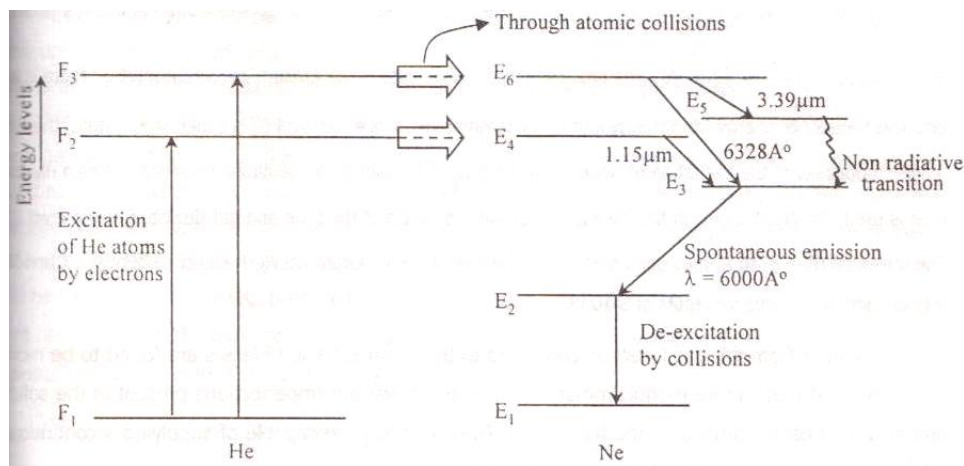

Fig.2.4. Energy level diagram of He-Ne atoms.

Ruby Laser

Ruby Laser is a solid state pulsed, three level lasers. It consists of a cylindrical shaped ruby crystal rod of length varying from 2 to 20cms and diameter varying 0.1 to 2cms. This end faces of the rod are highly flat and parallel. One of the faces is highly silvered and the other face is partially silvered so that it transmits 10 to 25% of incident light and reflects the rest so as to make the rod-resonant cavity. Basically, ruby crystal is aluminum oxide [Al_2O_3] doped with 0.05 to 0.5% of chromium atom. These chromium atoms serve as activators. Due to presence of 0.05% of chromium, the ruby crystal appears in pink color. The ruby crystal is placed along the axis of a helical xenon or krypton flash lamp of high intensity.

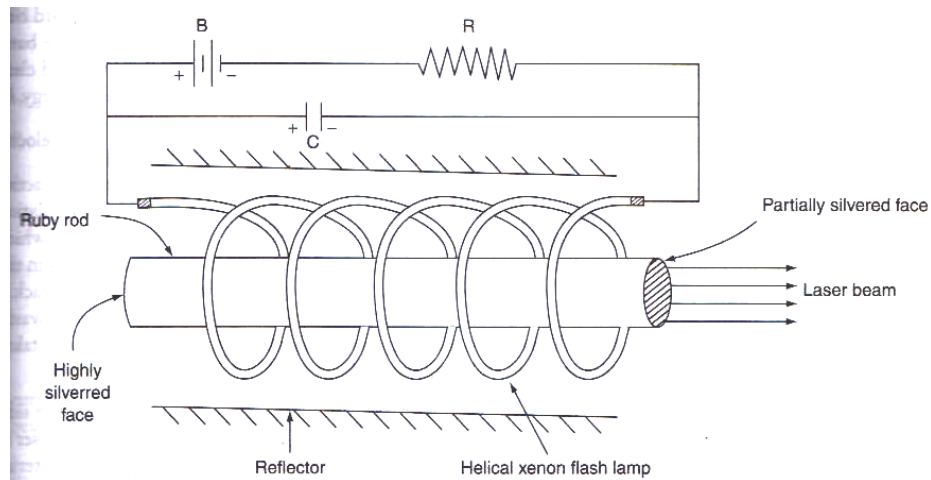

Fig.2.5 Ruby laser

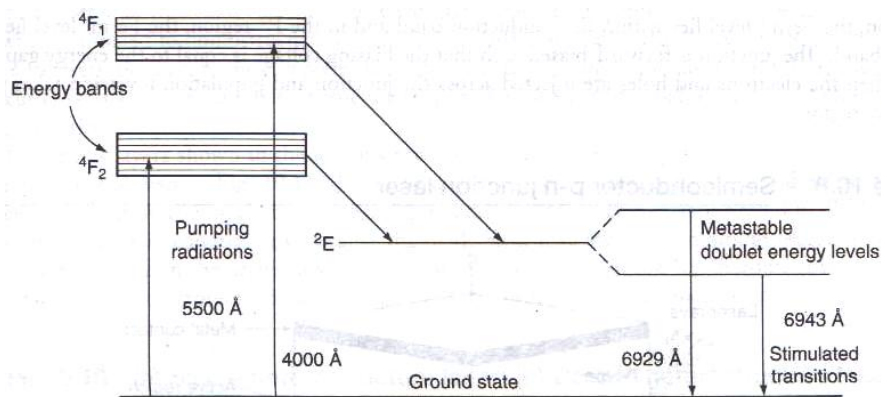

Fig.2.6 Energy level diagram of chromium ions in a ruby crystal

Construction:

Ruby ($\text{Al}_2\text{O}_3 + \text{Cr}_2\text{O}_3$) is a crystal of Aluminum oxide in which some of Al^{+3} ions are replaced by Cr^{+3} ions. When the doping concentration of Cr^{+3} is about 0.05%, the color of the rod becomes pink. The active medium in ruby rod is Cr^{+3} ions. In ruby laser a rod of 4cm long and 5mm diameter is used and the ends of the rod are highly polished. Both ends are silvered such that one end is fully reflecting and the other end is partially reflecting.

The ruby rod is surrounded by helical xenon flash lamp tube which provides the optical pumping to raise the Chromium ions to upper energy level (rather energy band). The xenon flash lamp tube which emits intense pulses lasts only few milliseconds and the tube consumes several thousands of joules of energy. Only a part of this energy is used in pumping Chromium ions while the rest goes as heat to the apparatus which should be cooled with cooling arrangements as shown in fig.2.5. The energy level diagram of ruby laser is shown in fig.2.6.

Working:

Ruby crystal is made up of aluminum oxide as host lattice with small percentage of Chromium ions replacing aluminum ions in the crystal chromium acts as do pant. A do pant actually produces lasing action while the host material sustains this action. The pumping source for ruby material is xenon flash lamp which will be operated by some external power supply. Chromium ions will respond to this flash light having wavelength of 5600\AA . When the Cr^{+3} ions are excited to energy level E_3 from E_1 the population in E_3 increases. Chromium ions stay here for a very short time of the order of 10^{-8} seconds then they drop to the level E_2 which is mat stable state of life time 10^{-3} s. Here the level E_3 is rather a band, which helps the pumping to be more effective. The transitions from E_3 to E_2 are non-radioactive in nature. During this process heat is given to crystal lattice. Hence cooling the rod is an essential feature in this method. The life time in mete stable state is 10^5 times greater than the lifetime in E_3 . As the life of the state E_2 is much longer, the number of ions in this state goes on increasing while ions. In this state goes on increasing while in the ground state (E_1) goes on decreasing. By this process population inversion is achieved between the exited Meta stable state E_2 and the ground state E_1 . When an excited ion passes spontaneously from the metastable state E_2 to the ground state E_1 , it emits a photon of wave length 6943\AA . This photon travels through the rod and if it is moving parallel to the axis of the crystal, is reflected back and forth by the silvered ends until it stimulates an excited ion in E_2 and causes it to emit fresh photon in phase with the earlier photon. This stimulated transition triggers the laser transition. This process is repeated again and again because the photons repeatedly move along the crystal being reflected from its ends. The photons thus get multiplied. When the photon beam becomes sufficiently intense, part of it emerges through the partially silvered end of the crystal.

Drawbacks of ruby laser:

1. The laser requires high pumping power to achieve population inversion.
2. It is a pulsed laser.

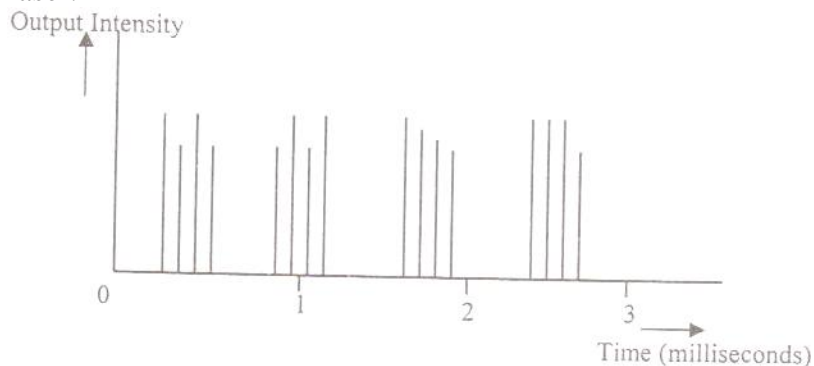

. Fig.2.7 the output pulses with time.

Applications of Lasers

Lasers find applications in various fields. They are described below:

a) In Communications :

Lasers are used in optical fiber communications. In optical fiber communications, lasers are used as light source to transmit audio, video signals and data to long distances without attention and distortion.

- b) The narrow angular spread of laser beam can be used for communication between earth and moon or to satellites.
- c) As laser radiation is not absorbed by water, so laser beam can be used in under water (inside sea) communication networks.

2. Industrial Applications

- a) Lasers are used in metal cutting, welding, surface treatment and hole drilling. Using lasers cutting can be obtained to any desired shape and the curved surface is very smooth.
- b) Welding has been carried by using laser beam.
- c) Dissimilar metals can be welded and micro welding is done with great ease.
- d) Lasers beam is used in selective heat treatment for tempering the desired parts in automobile industry
- e) Lasers are widely used in electronic industry in trimming the components of ICs

3. Medical Applications

1. Lasers are used in medicine to improve precision work like surgery. Brain surgery is an example of precision surgery Birthmarks, warts and discoloring of the skin can easily be removed with an unfocussed laser. The operations are quick and heal quickly and, best of all, they are less painful than ordinary surgery performed with a scalpel.
2. Cosmetic surgery (removing tattoos, scars, stretch marks, sunspots, wrinkles, birthmarks and hairs) lasers hair removal.
3. Laser types used in dermatology include ruby(694nm), alexandrite(755nm), pulsed diode array(810nm), Nd:YAG (1064nm), HO:YAG(2090nm), and Er:YAG (2940nm)
4. Eye surgery and refracting surgery.
5. Soft tissue surgery: Co₂ Er:YAG laser.
6. Laser scalpel (general surgery, gynecological, urology, laparoscopic).
7. Dental procedures.
8. Photo bio modulation (i.e. laser therapy)
9. “No-touch” removal of tumors, especially of the brain and spinal cord.
10. In dentistry for caries removal, endodontic/periodontic, procedures, tooth whitening, and oral surgery.

4. Military Applications

The various military applications are:

- a) **Death rays:** By focusing high energetic laser beam for few seconds to aircraft, missile, etc can be destroyed. So, these rays are called death rays or war weapons.
- b) **Laser gun:** The vital part of energy body can be evaporated at short range by focusing highly convergent beam from a laser gun.
- c) **LIDAR (Light detecting and ranging):** In place of RADAR, we can use LIDAR to estimate the size and shape of distant objects or war weapons. The differences between RADAR and LIDAR are that, in case of RADAR, Radio waves are used where as in case of LIDAR light is used.

5. In Computers: By using lasers a large amount of information or data can be stored in CD-ROM or their storage capacity can be increased. Lasers are also used in computer printers.

6. In Thermonuclear fusion: To initiate nuclear fusion reaction, very high temperature and pressure is required. This can be created by concentrating large amount of laser energy in a small volume. In the fusion of deuterium and tritium, irradiation with a high energy laser beam pulse of 1 nano second duration develops a temperature of 10^{17} °c, this temperature is sufficient to initiate nuclear fusion reaction.

7. In Scientific Research: In scientific, lasers are used in many ways including

- a) A wide variety of interferometric techniques.
- b) Raman spectroscopy.
- c) Laser induced breakdown spectroscopy.
- d) Atmospheric remote sensing.
- e) Investigating non linear optics phenomena
- f) Holographic techniques employing lasers also contribute to a number of measurement techniques.
- g) Laser (LADAR) technology has application in geology, seismology, remote sensing and atmospheric physics.
- h) Lasers have been used aboard spacecraft.
- i) In astronomy lasers have been used to create artificial laser guide stars, used as reference objects for adaptive optics telescope.

FIBER OPTICS

Introduction

1. An optical fiber (or fiber) is a glass or plastic fiber that carries light along its length.
2. Fiber optics is the overlap of applied science and engineering concerned with the design and application of optical fibers.
3. Optical fibers are widely used in fiber-optic communications, which permits transmission over long distances and at higher band widths (data rates) than other forms of communications.
4. Specially designed fibers are used for a variety of other applications, including sensors and fiber lasers. Fiber optics, though used extensively in the modern world, is a fairly simple and old technology.

Principle of Optical Fiber

Optical fiber is a cylinder of transparent dielectric medium and designed to guide visible and infrared light over long distances. Optical fibers work on the principle of **total internal reflection**.

Optical fiber is very thin and flexible medium having a cylindrical shape consisting of three sections

- 1) The core material
- 2) The cladding material
- 3) The outer jacket

The structure of an optical is shown in figure. The fiber has a core surrounded by a cladding material whose reflective index is slightly less than that of the core material to satisfy the condition for total internal reflection. To protect the fiber material and also to give mechanical support there is a protective cover called outer jacket. In order to avoid damages there will be some cushion between cladding protective cover.

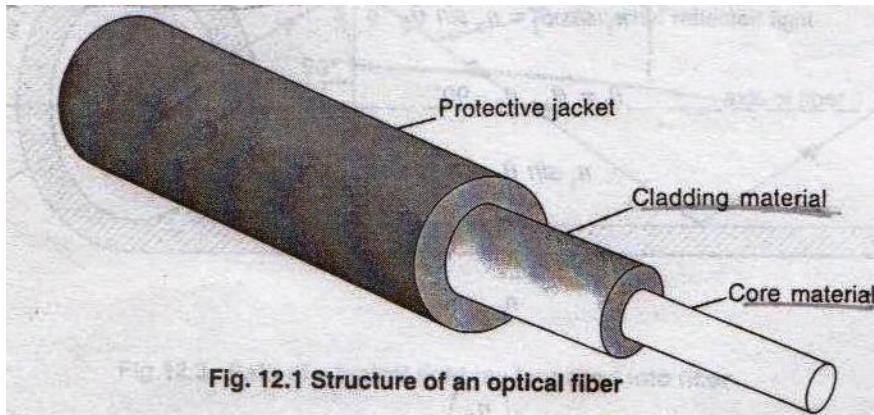

Fig. 12.1 Structure of an optical fiber

Fig..Structure of an optical fiber

When a ray of light passes from an optically denser medium into an optically rarer medium the refracted ray bends away from the normal. When the angle of incidence is increased angle of refraction also increases and a stage is reached when the refracted ray just grazes the surface of separation of core and cladding. At this position the angle of refraction is 90 degrees. This angle of incidence in the denser medium is called the **critical angle (θ_c)** of the denser medium with respect to the rarer medium and is shown in the fig. If the angle of incidence is further increased then light gets totally reflected. This is called total **internal reflection**. Let the refractive indices of core and cladding materials be n_1 and n_2 respectively.

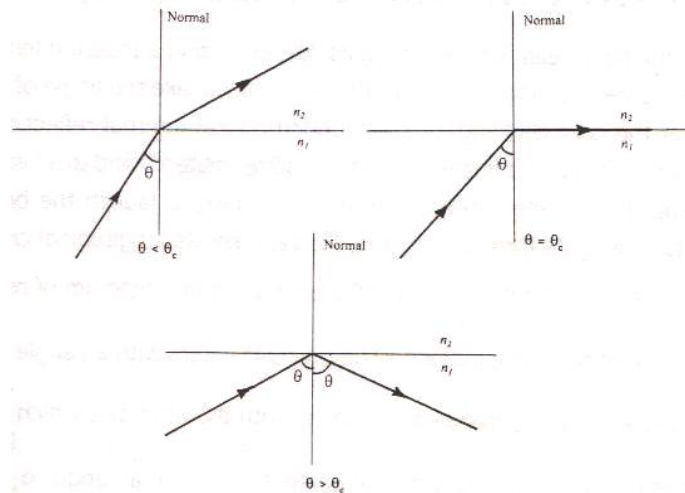

Fig. Total internal reflection.

When a light ray travels from an optically denser medium into an optically rarer medium is incident at angle greater than the critical angle for the two media. The ray is totally reflected back into the medium by obeying the law of reflection. This phenomenon is known as totally internal reflection.

According to law of refraction,

$$n_1 \sin\theta_1 = n_2 \sin\theta_2$$

Here $\theta_1 = \theta_c$, $\theta_2 = 90$

$$n_1 \sin\theta_c = n_2 \sin 90$$

$$\sin \theta_c = \frac{n_2}{n_1}$$

$$\theta_c = \sin^{-1}\left(\frac{n_2}{n_1}\right) \rightarrow (1)$$

Equation (1) is the expression for condition for total internal reflection. In case of total internal reflection, there is absolutely no absorption of light energy at the reflecting surface. Since the entire incident light energy is returned along the reflected light it is called total internal reflection. As there is no loss of light energy during reflection, hence optical fibers are designed to guide light wave over very long distances.

Acceptance Angle and Acceptance Cone

Acceptance angle: It is the angle at which we have to launch the beam at its end to enable the entire light to propagate through the core. Fig.8.12 shows longitudinal cross section of the launch of a fiber with a ray entering it. The light is entered from a medium of refractive index n_0 (for air $n_0=1$) into the core of refractive index n_1 . The ray (OA) enters with an angle of incidence to the fiber end face i.e. the incident ray makes angle with the fiber axis which is nothing but the normal to the end face of the core. Let a right ray OA enters the fiber at an angle to the axis of the fiber. The end at which light enter the fiber is called the **launching pad**.

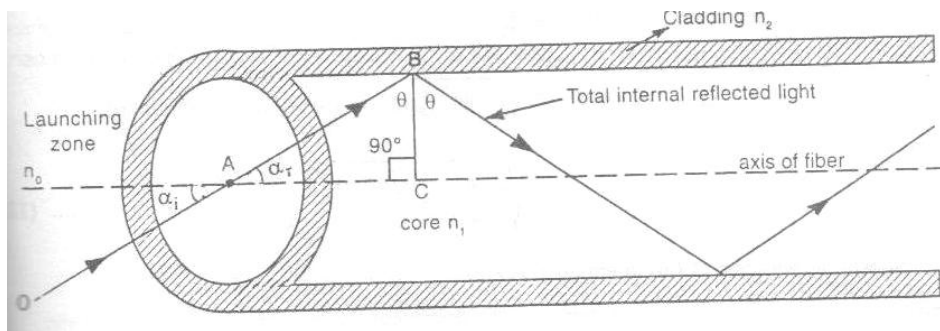

Fig. Path of atypical light ray launched into fiber.

Let the refractive index of the core be n_1 and the refractive index of cladding be n_2 . Here $n_1 > n_2$. The light ray reflects at an angle and strikes the core cladding interface at angle θ . If the angle θ is greater than its critical angle θ_c , the light ray undergoes total internal reflection at the interface.

According to Snell's law

$$n_0 \sin \alpha_i = n_1 \sin \alpha_r \rightarrow (2)$$

From the right angled triangle ABC

$$\alpha_r + \theta = 90^\circ$$

$$\alpha_r = 90^\circ - \theta \rightarrow (3)$$

Substituting (3) in (2), we get

$$n_0 \sin \alpha_i = n_1 \sin (90^\circ - \theta) = n_1 \cos \theta$$

$$\sin \alpha_i = \left(\frac{n_1}{n_0}\right) \cos \theta \quad \rightarrow(4)$$

When $\theta = \theta_c$, $\alpha_i = \alpha_m = \text{maximum } \alpha \text{ value}$

$$\sin \alpha_m = \left(\frac{n_1}{n_0}\right) \cos \theta_c \rightarrow(5)$$

From equation (1) $\sin \theta_c = \frac{n_2}{n_1}$

$$\cos \theta_c = \sqrt{1 - \sin^2 \theta_c} = \sqrt{1 - \left(\frac{n_2}{n_1}\right)^2} = \frac{\sqrt{n_1^2 - n_2^2}}{n_1} \quad \rightarrow(6)$$

Substitute equation (6) in equation (5)

$$\sin \alpha_m = \left(\frac{n_1}{n_0}\right) \frac{\sqrt{n_1^2 - n_2^2}}{n_1} = \frac{\sqrt{n_1^2 - n_2^2}}{n_0} \quad \rightarrow(7)$$

If the medium surrounding fiber is air, then $n_0 = 1$

$$\sin \alpha_m = \sqrt{n_1^2 - n_2^2} \quad \rightarrow(8)$$

This maximum angle is called the **acceptance angle or the acceptance cone half angle** of the fiber.

The **acceptance angle** may be defined as the maximum angle that a light ray can have with the axis of the fiber and propagate through the fiber. Rotating the acceptance angle about the fiber axis (fig.) describes the acceptance cone of the fiber. Light launched at the fiber end within this acceptance cone alone will be accepted and propagated to the other end of the fiber by total internal reflection. Larger acceptance angles make launching easier. Light gathering capacity of the fiber is expressed in terms of maximum acceptance angle and is termed as “**Numerical Aperture**”.

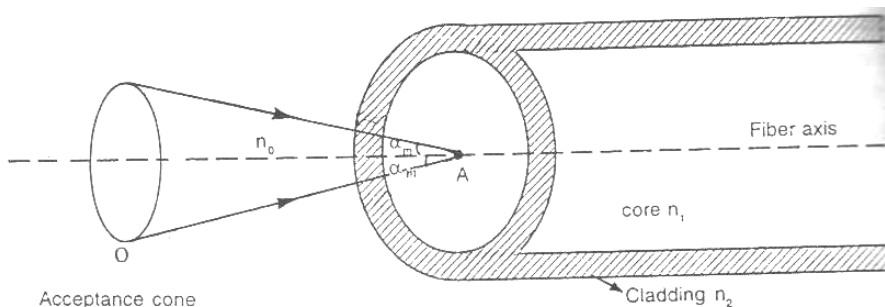

Fig. Acceptance cone

Numerical Aperture

Numerical Aperture of a fiber is measure of its light gathering power. The numerical aperture (NA) is defined as the sign of the maximum acceptance angle.

$$\text{Numerical aperture (NA)} = \sin \alpha_m = \sqrt{n_1^2 - n_2^2} \quad \rightarrow(9)$$

$$\begin{aligned} &= \sqrt{(n_1 - n_2)(n_1 + n_2)} \\ &= \sqrt{((n_1 + n_2) n_1 \Delta)} \end{aligned} \quad \rightarrow(10)$$

Where $\Delta = \frac{(n_1 - n_2)}{n_1}$ called as fractional differences in refractive indices n_1 and n_2 are the refractive indices of core and cladding material respectively.

As $n_1 \approx n_2$, we can take $n_1 + n_2 = 2n_1$

$$\text{Then numerical aperture} = (2n_1^2 \Delta)^{1/2} = n_1 (2\Delta)^{1/2} \rightarrow (11)$$

Numerical aperture is a measure of amount of light that can be accepted by a fiber. From equation (9) it is seen that numerical aperture depends only on the refractive indices of core and cladding materials and it is independent on the fiber dimensions. Its value ranges from 0.1 to 0.5. A large NA means that the fiber will accept large amount of light from the source.

Proof:

We shall show that the light emitted by a small diffuse source situated on the fiber axis near to one end face, only a fraction NA^2 can be collected by the fiber and propagated along the fiber. Consider a small diffuse light source such as the isotropic radiator in which the power radiated per unit solid angle in a direction θ to the normal to the surface

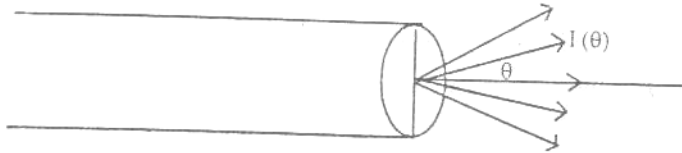

is given by

Fig. Diffuse light source

$$I(\theta) = I_0 \cos \theta \rightarrow (12)$$

The total power ϕ_0 emitted such source is obtained by integrating $I(\theta)$ over all forward directions

$$\phi_0 = \int_0^{\pi/2} I_0 \cos \theta d\theta \rightarrow (13)$$

Where $d\Omega = \text{small element of solid angle} = 2\pi \sin \theta d\theta \rightarrow (14)$

$$\begin{aligned} \phi_0 &= \int_0^{\pi/2} I_0 \cos \theta 2\pi \sin \theta d\theta \\ &= \int_0^{\pi/2} \pi I_0 \sin 2\theta d\theta = \pi I_0 \rightarrow (15) \end{aligned}$$

But the power from such source that can be collected by an adjacent fiber whose core diameter is greater than the diameter of the source is given by Φ , where

$$\begin{aligned} \Phi &= \int_0^{\alpha_m} I_0 \cos \theta 2\pi \sin \theta d\theta \\ &= \pi I_0 \sin 2\alpha_m \\ (\Phi / \phi_0) &= (\sin \alpha_m)^2 = (NA)^2 = 2n_1^2 \Delta \rightarrow (16) \end{aligned}$$

Where $\Delta = \frac{(n_1 - n_2)}{n_1}$

Equation (16) represents the light gathering power of the fiber. In order to collect as much light as possible it is necessary to make n_1 and Δ large.

In some cases it is customary to use Δn which can be defined as $\Delta n = n_1 - n_2$

But $\Delta = \frac{(n_1 - n_2)}{n_1} = \frac{\Delta n}{n_1}$

$$(\Phi / \phi_0) = (\sin \alpha_m)^2 = (NA)^2 = 2n_1 \Delta n \rightarrow (17)$$

$$NA = (2n_1 \Delta n) \rightarrow (18)$$

Step index fibers and graded index fiber -transmission of signals in them:

Based on the variation of refractive index of core, optical fibers are divided into: (1) step index and (2) graded index fibers. Again based on the mode of propagation, all these fibers are divided into: (1) single mode and (2) multimode fibers. In all optical fibers, the refractive index of cladding material is uniform. Now, we will see the construction, refractive index of core and cladding with radial distance of fiber, ray propagation and applications of above optical fibers.

i. **Step index fiber:** The refractive index is uniform throughout the core of this fiber. As we go radially in this fiber, the refractive index undergoes a step change at the core-cladding interface. Based on the mode of propagation of light rays, step index fibers are of 2 types: a) single mode step index fiber & b) multimode step index fibers. Mode means, the number of paths available for light propagation of fiber. We describes the different types of fiber below

a) **Single mode step index fiber:** The core diameter of this fiber is about 8 to 10 μm and outer diameter of cladding is 60 to 70 μm . There is only one path for ray propagation. So, it is called **single mode fiber**. The cross sectional view, refractive index profile and ray propagation are shown in fig. (i). In this fiber, the transmission of light is by successive total internal reflections i.e. it is a reflective type fiber. Nearly 80% of the fibers manufactured today in the world are single mode fibers. So, they are extensively used.

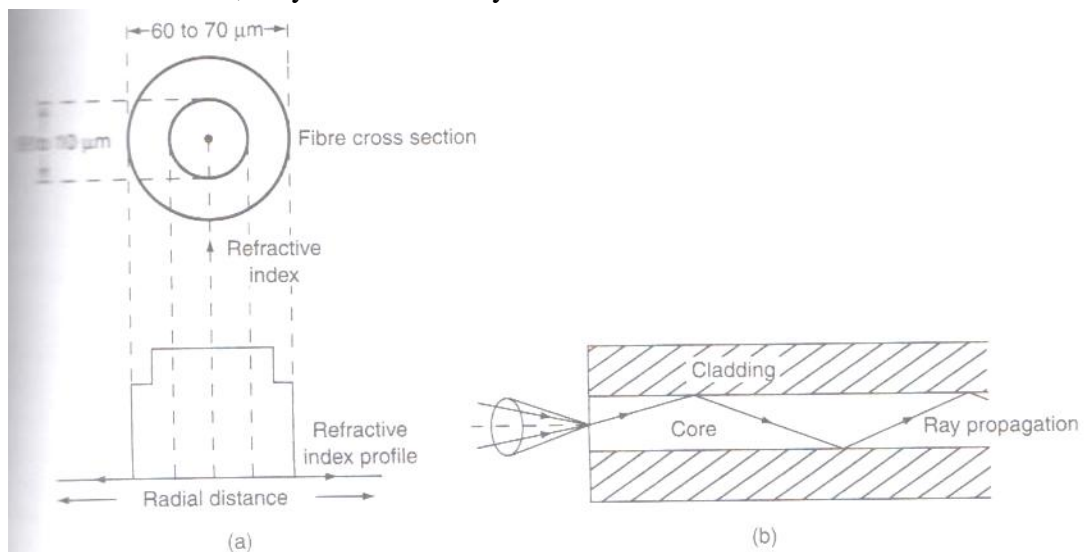

Fig (i).Single mode step index fiber ;(a) Cross sectional view and refractive index profile ;(b) Ray propagation

Multimode step index fiber: The construction of multimode step index fiber is similar to single mode step index fiber except that its core and cladding diameters are much larger to have many paths for light propagation. The core diameter of this fiber varies from 50 to 200 μm and the outer diameter of cladding varies from 100 to 250 μm . The cross-sectional view, refractive index profile and ray propagations are

shown in fig 2. Light propagation in this fiber is by multiple total internal reflections i.e it is a reflective type fiber.

- b) **Transmission of signal in step index fiber:** Generally the signal is transmitted through the fiber in digital form i.e. in the form of 1's and 0's. The propagation of pulses through the multimode fiber is shown in fig (i)(b). The pulse which travels along path 1 (straight) will reach first at the other end of fiber. Next the pulse that travels along with path 2 (zig-zag) reaches the other end. Hence, the pulsed signal received at the other end is broadened. This is known as intermodal dispersion. This imposes limitation on the separation between pulses and reduces the transmission rate and capacity. To overcome this problem, graded index fibers are used.

2) **Graded index fiber:** In this fiber, the refractive index decreases continuously from center radially to the surface of the core. The refractive index is maximum at the center and minimum at the surface of core. This fiber can be single mode or multimode fiber. The cross sectional view, refractive index profile and ray propagation of multimode graded index fiber are shown in fig. (ii)(a). The diameter of core varies from 50 to 200 μm and outer diameter of cladding varies from 100 to 250 μm .

The refractive index profile is circularly symmetric. As refractive index changes continuously radially in core, light rays suffer continuous refraction in core. The propagation of light ray is not due to total internal reflection but by refraction as shown in fig. (ii)(b). in graded index fiber, light rays travel at different speed in different paths of the fiber. Near the surface of the core, the refractive index is lower, so rays near the outer surface travel faster than the rays travel at the center. Because of this, all the rays arrive at the receiving end of the fiber approximately at the same time. This fiber is costly. .

Transmission of signal graded index fiber: In multimode graded index fiber, large number of paths is available for light ray propagation. To discuss about inter modal dispersion, we consider ray path 1 along the axis of fiber.

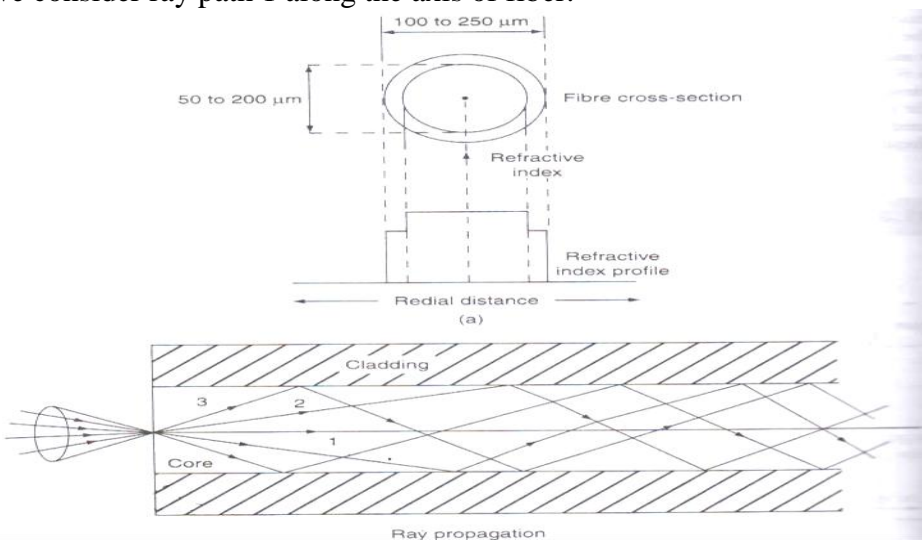

Fig. (ii).Multimode step index fibre(a)Cross sectional view and refractive index profile(b)Ray propagation

As shown in fig. (ii)(b) and another ray path 2. Along with the axis of fiber, the refractive index of core is maximum, so the speed of ray along path 1 is less. Path 2 is sinusoidal and it is longer, along this path refractive index varies. The ray mostly travels in low refractive region, so the ray 2 moves slightly faster. Hence, the pulses of signals that travel along path 1 and path 2 reach other end of fiber simultaneously. Thus, the problem of intermodal dispersion can be reduced to a large extent using graded index fibers.

Differences between step index fiber and graded index fibers:

Step index fiber	Graded index fiber
1.The refractive index of core Is uniform and step or abrupt Change in refractive index Takes place at the interface of core and cladding in step index fibers	1.The refractive index of core is non uniform, the refractive index of core decreases Parabolicity from the axis of the fiber to its surface.
2. The light rays propagate in zigzag manner inside the core. The rays travel in the fiber as meridional rays they cross the fiber axis for every reflection.	2. Light rays propagate in the form of skew rays or helical rays. They will not cross the fiber axis

Difference between single mode fibers and multi mode fibers:

Single mode fiber	Multimode fiber
1. In single mode fiber there is only one path for ray propagation	1. In multimode fiber, large number of paths is available for light ray propagation.
2. A single mode step index fiber has less core diameter ($< 10 \mu\text{m}$) and the difference between the reflective indices of core and cladding is very small.	2. Multi mode fibers, large number of paths are available for light ray propagation.
3. In single mode fibers, there is no dispersion.	3. There is signal distortion and dispersion takes place in multimode fibers.
4. The band width is about 50 MHz for multimode step index fiber where as it is more than 1000 MHz km in case of single mode step index fiber.	4. The band width of the fiber lies in between 200 MHz km to 600 MHz km even though theoretically it has an infinite bandwidth.
5. NA of multimode step index fiber is more where as in single mode step index fibers, it is very less.	5. NA of graded index fibers is less.
6. Launching of light into single mode	6. Launching of light into multimode

fibers is difficult.	fibers is easy.
7. Fabrication cost is very high.	7. Fabrication cost is less

Fiber optic communication system :

Fiber optic essentially deals of with the communication(including voice signals,video signals or digital data) by transmission of light through optical fibers. Optical fiber communication system essentially consists of three parts:(a)transmitter (b) optical fiber and (c) receiver.The transmitter includes modulator, encoder, light source, drive circuits and couplers. The receiver includes amplifier and decoder,binary electrical signal and light decoder.

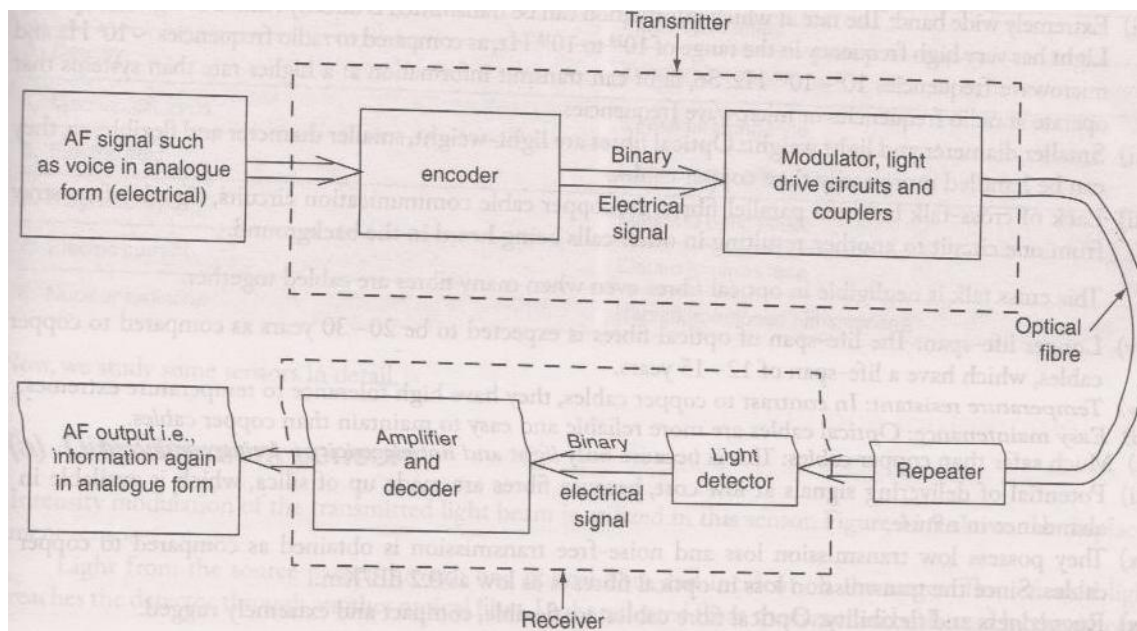

Fig. Block diagram represents optical fibre communication system

MODULE-IV LIGHT AND OPTICS

INTERFERENCE AND DIFFRACTION

Interference-Introduction

Wave Theory of light attempts to understand the various optical phenomena exhibited by light waves. Interference constituted the first proof of the wave nature of light. Thomas Young first experimentally demonstrated interference in light waves. The superposition principle forms the conceptual basis for the explanation of interference. To produce interference, the light waves should be coherent, i.e., the light waves should have constant phase difference and same frequencies.

Interference

When two or more light waves superimpose in the medium then according to superposition principle, the resultant displacement at any point is equal to the algebraic sum of the displacements due to individual waves. The variation of resultant displacement influences amplitude variation, which causes intensity variations. This modification in the distribution of intensity in the region of superposition is known as interference. When the resultant amplitude is the sum of the amplitudes due to two light waves, the interference is *constructive interference*. If the resultant amplitude is equal to the difference of two amplitudes, the interference becomes *destructive interference*. The intensity variations are studied as interference fringes or patterns.

Conditions for Interference

1. The two light sources emitting light waves should be coherent.
2. The two sources must emit continuous light waves of same wavelengths and frequency.
3. The separation between the two sources should be small.
4. The distance between the two sources and the screen should be large.
5. To view interference fringes, the background should be dark.
6. The amplitudes of the light waves should be equal or nearly equal.
7. The sources should be narrow, i.e., they must be small.
8. The sources should be monochromatic.

Young's Double Slit Experiment

This is a classic example of interference effects in light waves. Two light rays pass through two slits, separated by a distance d and strike a screen a distance, L , from the slits, as in Fig. [22.10](#).

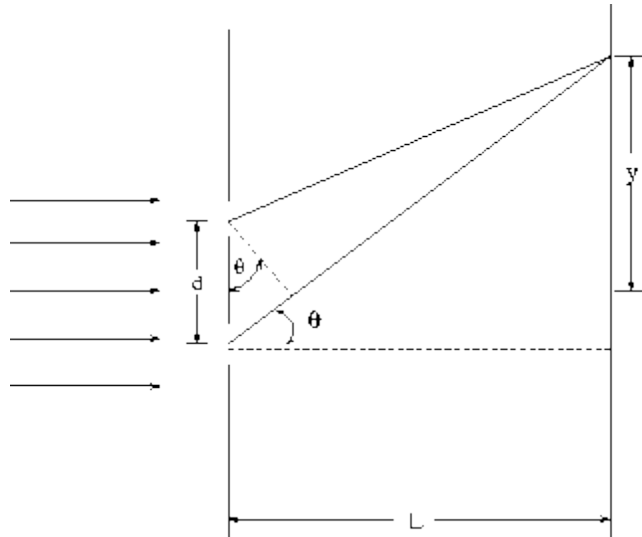

Figure 22.10: Double slit diffraction

If $d \ll L$ then the difference in path length $r_1 - r_2$ travelled by the two rays is approximately:

$$r_1 - r_2 \approx d \sin \theta$$

where θ is approximately equal to the angle that the rays make relative to a perpendicular line joining the slits to the screen.

If the rays were in phase when they passed through the slits, then the condition for constructive interference at the screen is:

$$d \sin \theta = m \lambda, m = \pm 1, \pm 2, \dots$$

where as the condition for destructive interference at the screen is:

$$d \sin \theta = (m + \frac{1}{2}) \lambda, m = \pm 1, \pm 2, \dots$$

The points of constructive interference will appear as bright bands on the screen and the points of destructive interference will appear as dark bands. These dark and bright spots are called *interference fringes*. **Note:**

- In the case that y , the distance from the interference fringe to the point of the screen opposite the center of the slits (see Fig) is much less than L ($y \ll L$), one can use the approximate formula:

$$\sin \theta \approx y/L$$

so that the formulas specifying the y - coordinates of the bright and dark spots, respectively are:

$$y_m^B = \frac{m\lambda L}{d} \quad \text{bright spots}$$

$$y_m^D = \frac{(m + \frac{1}{2})\lambda L}{d} \quad \text{dark spots}$$

The spacing between the dark spots is

$$\Delta y = \frac{\lambda L}{d}$$

- If $d \ll L$ then the spacing between the interference can be large even when the wavelength of the light is very small (as in the case of visible light). This gives a method for (indirectly) measuring the wavelength of light. (See Ex.6 at the end of this Chapter.)
- The above formulas assume that the slit width is very small compared to the wavelength of light, so that the slits behave essentially like point sources of light.

Conditions for Interference

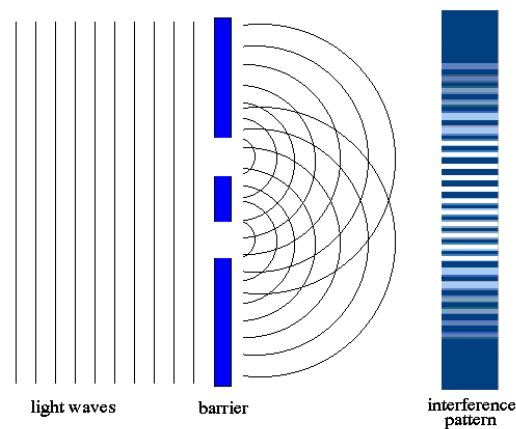

Observable interference can take place if the following conditions are fulfilled:

- The two sources should emit, continuously, waves of some wave-length or frequency. While deriving conditions for maxima and minima, we have taken 'I' for both the waves to be same.
- The amplitudes of the two waves should be either or nearly equal. A good contrast between a maxima and minima can only be obtained if the amplitudes of two waves are equal or nearly equal.

(c) The two sources should be narrow. A broader source can be supposed to be a combination of a number of narrow sources assembled side-by-side. Interference patterns due to these narrow sources may overlap each other.

(d) The sources should be close to each other. The fringe width varies inversely as distance 'd' between the two sources. So, interference pattern will be more clear and distant if 'd' is small.

(e) The two sources should be coherent one.

Young's Double Slit Experiment

The phenomenon of interference was first observed and demonstrated by Thomas Young in 1801. The experimental set up is shown in figure.

Light from a narrow slit S, illuminated by a monochromatic source, is allowed to fall on two narrow slits A and B placed very close to each other. The width of each slit is about 0.03 mm and they are about 0.3 mm apart. Since A and B are equidistant from S, light waves from S reach A and B in phase. So A and B acts as coherent sources.

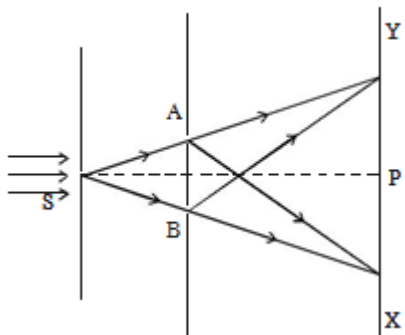

According to Huygen's principle, wavelets from A and B spread out and overlapping takes place to the right side of AB. When a screen XY is placed at a distance of about 1 meter from the slits, equally spaced alternate bright and dark fringes appear on the screen. These are called interference fringes or bands. Using an eyepiece, the fringes can be seen directly. At P on the screen, waves from A and B travel equal distances and arrive in phase. These two waves constructively interfere and bright fringe is observed at P. This is called central bright fringe.

When one of the slits is covered, the fringes disappear and there is uniform illumination on the screen. This shows clearly that the bands are due to interference.

Let d be the distance between two coherent sources A and B of wavelength λ . A screen XY is placed parallel to AB at a distance D from the coherent sources. C is the midpoint of AB. O is a point on the screen equidistant from A and B. P is a point at a distance x from O, as shown in Fig

5.17. Waves from A and B meet at P in phase or out of phase depending upon the path difference between two waves draw AM perpendicular to BP.

The path difference $\delta = BP - AP$

$$AP = MP$$

$$\delta = BP - AP = BP - MP = BM$$

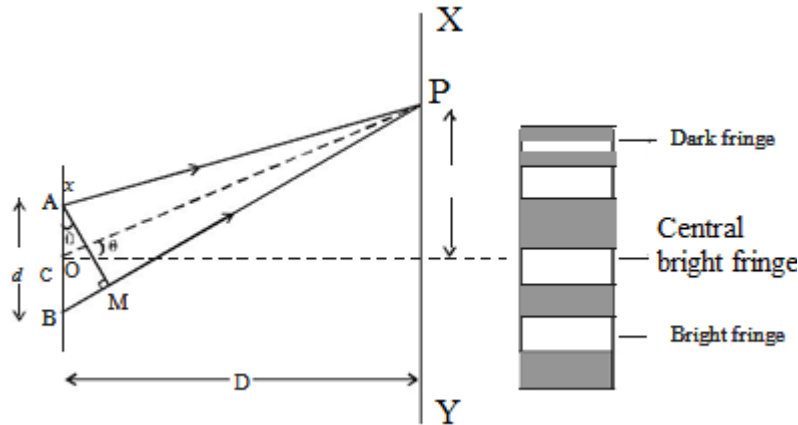

In right angled? ABM, $BM = d \sin \theta$ If θ is small,

$$\sin \theta = \theta$$

The path difference $\delta = \theta \cdot d$

In right angled triangle COP, $\tan \theta = OP/CO = x/D$

For small values of θ , $\tan \theta = \theta$

Thus, the path difference $\delta = xd/D$

Bright Fringes

By the principle of interference, condition for constructive interference is the path difference = $n\lambda$

$$xd/D = n\lambda$$

Here, $n = 0, 1, 2, \dots$ indicate the order of bright fringes

$$\text{So, } x = (D/d) n\lambda$$

This equation gives the distance of the n^{th} bright fringe from the point O.

Dark Fringes

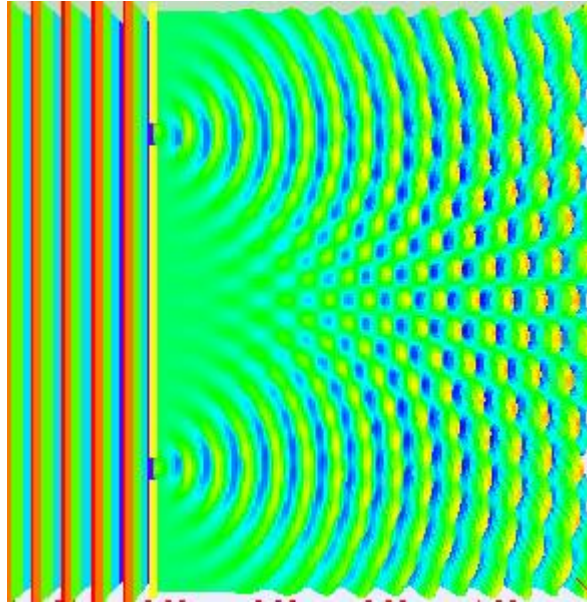

By the principle of interference, condition for destructive interference is the

$$\text{path difference} = (2n-1)\lambda/2$$

Here, $n = 1, 2, 3 \dots$ indicate the order of the dark fringes.

$$\text{So, } x = (D/d) [(2n - 1) \lambda/2]$$

This equation gives the distance of the n^{th} dark fringe from the point O. Thus, on the screen alternate dark and bright bands are seen on either side of the central bright band.

Band Width (β)

The distance between any two consecutive bright or dark bands is called bandwidth.

The distance between $(n+1)^{\text{th}}$ and n^{th} order consecutive bright fringes from O is given by,

$$x_{n+1} - x_n = [(D/d) [(n+1) \lambda] - (D/d) [(n)\lambda]] = (D/d) \lambda$$

$$\text{Bandwidth, } \beta = (D/d) \lambda$$

Similarly, it can be proved that the distance between two consecutive dark bands are also equal to $(D/d) \lambda$. Since bright and dark fringes are of same width, they are equispaced on either side of central maximum.

Condition for Obtaining Clear and Broad Interference Bands

The screen should be as far away from the source as possible.

The wavelength of light used must be larger.

The two coherent sources must be as close as possible.

Interference in Thin Film by Reflection

When light is incident on a plane parallel thin film, some portion gets reflected from the upper surface and the remaining portion is transmitted into the film. Again, some portion of the transmitted light is reflected back into the film by the lower surface and emerges through the upper surface. These reflected light beams superimpose with each other, producing interference and forming interference patterns.

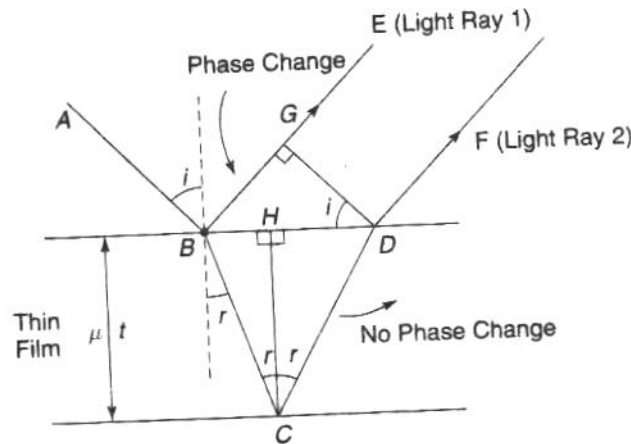

Fig Interference in thin film

Consider a transparent plane parallel thin film of thickness 't' with refractive index μ . Let a monochromatic light ray AB be incident at an angle of incidence of 'i' on the upper surface of the film. BE and BC are the reflected and transmitted light rays. Let the angle of refraction is 'r'. The ray BC will be reflected into the film and emerge through the film in the form of light ray DF. These two light rays superimpose and depending upon the path difference between them, they produce interference patterns.

To know the path difference, draw the normal DG to BE. From the points D and G onwards, the light rays travel equal distances. By the time the light ray travels from B to G, the transmitted light ray has to travel from B to C and C to D.

The path difference between light rays (1) and (2) is,

$$\text{Path difference} = \mu(BC + CD) \text{ in film} - BG \text{ in air} \quad \rightarrow(1)$$

$$\text{Consider the } \triangle BCH, \cos r = \frac{HC}{BC}$$

$$BC = \frac{HC}{\cos r} = \frac{t}{\cos r}$$

$$\text{Similarly, from } \triangle DCH, CD = \frac{t}{\cos r}$$

$$BC = CD = \frac{t}{\cos r} \quad \rightarrow(2)$$

To calculate BG, first BD which is equal to (BH+HD) has to be obtained.

From ΔBHC

$$\tan r = \frac{BH}{CH} = \frac{BH}{t}$$

$$BH = t \tan r$$

Similarly,

$$HD = t \tan r$$

$$BD = BH + HD = 2t \tan r \quad (\because BH = HD) \quad \rightarrow(3)$$

From ΔBGD ,

$$\sin i = \frac{BG}{BD}$$

$$BG = BD \sin i = 2t \tan r \sin i$$

From Snell's law, $\sin i = \mu \sin r$

$$BG = 2 \mu t \tan r \sin r \quad \rightarrow(4)$$

Substituting the above values in Eq. (1)

$$\begin{aligned} \text{Path difference} &= \frac{2\mu t}{\cos r} - 2 \mu t \tan r \sin r \\ &= \frac{2\mu t}{\cos r} - \frac{2\mu t \sin^2 r}{\cos r} \\ &= \frac{2\mu t}{\cos r} (1 - \sin^2 r) = \frac{2\mu t}{\cos r} \cos^2 r \\ &= 2\mu t \cos r \quad \rightarrow(5) \end{aligned}$$

At the point B, reflection occurs from the upper surface of the thin film (denser medium). Light ray (1) undergoes an additional phase change of π or an additional path difference of $\frac{\lambda}{2}$

$$\text{Total path difference} = 2\mu t \cos r + \frac{\lambda}{2}$$

When the path difference is equal to integral multiple of λ , then the rays (1) and (2) meet in phase and undergo constructive interference.

The condition for bright fringe is

$$2\mu t \cos r + \frac{\lambda}{2} = n \lambda$$

$$2\mu t \cos r = (2n-1) \frac{\lambda}{2} \quad \text{where } n=0,1,2,3\dots \quad \rightarrow(6)$$

When the path difference is equal to half integral multiple of λ , then the rays (1) and (2) meet in out of phase and undergo destructive interference.

The condition for dark fringe is

$$2\mu t \cos r + \frac{\lambda}{2} = (2n-1) \frac{\lambda}{2}$$

$$2\mu t \cos r = n \lambda \quad \text{where } n=0, 1, 2, 3\dots \quad \rightarrow(7)$$

Depending on the above conditions, the interference pattern consists of bright and dark fringes.

Newton's Rings

Newton's rings are one of the best examples for the interference in a nonuniform thin film. When a Plano-convex lens with its convex surface is placed on a plane glass plate, an air film of increasing thickness is formed between the two. The thickness of the film at the point of contact is zero. If monochromatic light is allowed to fall normally and the film is viewed in the reflected light, alternate dark and bright rings concentric around the point of contact between the lens and glass plate are seen. These circular rings were discovered by Newton and are called Newton's rings.

Experimental Arrangement

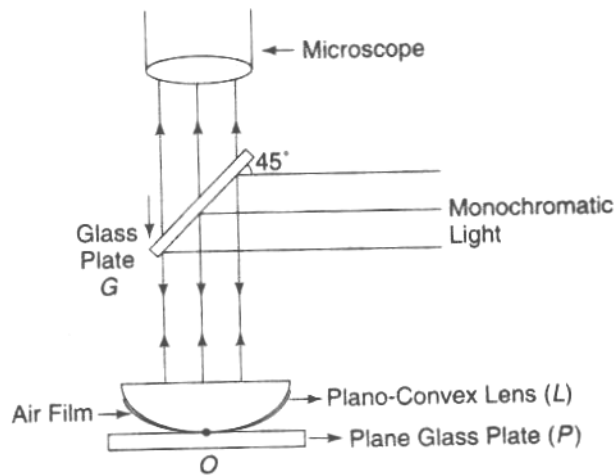

Fig Newton's rings (Experimental set up)

The experimental arrangement is as shown in fig. The Plano-convex lens (L) of large radius of curvature is placed with its convex surface on a plane glass plate (P). The lens makes the contact with the plate at 'O'. The monochromatic light falls on a glass plate G held at an angle of 45° with the vertical. The glass plate G reflects normally a part of the incident light towards the air film enclosed by the lens L and the glass plate P. A part of the light is reflected by the curved surface of the lens L and a part is transmitted which is reflected back from the plane surface of the plate. These reflected rays interfere and give rise to an interference pattern in the form of circular rings. These rings are seen near the upper surface of the air film through the microscope.

Explanation of Newton's Rings

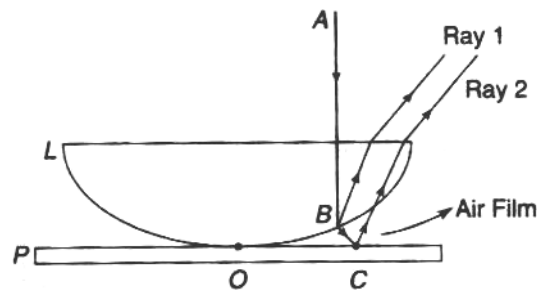

Fig. Formation of Newton's rings

Newton's rings are formed due to interference between the light rays reflected from the top and bottom surfaces of air film between the plate and the lens. The formation of Newton's rings can be explained with the help of Fig. A part of the incident monochromatic light AB is reflected at B (glass-air boundary) in the form of the ray (1) with any additional phase (or path) change. The other part of light is refracted along BC. Then at C (air-glass boundary), it is again reflected in the form of the ray (2) with additional phase change of π or path change of $\frac{\lambda}{2}$.

As the rings are observed in the reflected light, the path difference between them is $2\mu t \cos r + \frac{\lambda}{2}$.
 For air film $\mu = 1$ and for normal incidence $r=0$, path difference is $2t + \frac{\lambda}{2}$.

At the point of contact $t=0$, path difference is $\frac{\lambda}{2}$, i.e., the reflected light at the point of contact suffers phase change of π . Then the incident and reflected lights are out of phase and interfere destructively. Hence the central spot is dark.

The condition for bright ring is $2t + \frac{\lambda}{2} = n \lambda$

$$2t = (2n-1)\frac{\lambda}{2} \quad \text{where } n=1, 2, 3 \dots$$

The condition for dark ring is

$$2t + \frac{\lambda}{2} = (2n+1)\frac{\lambda}{2}$$

$$2t = n \lambda \quad \text{where } n=0, 1, 2, 3 \dots$$

For monochromatic light, the bright and dark rings depend on thickness of the air film. For a Newton's rings system, the focus of points having same thickness lie on a circle having its centre at the point of contact. Thus, we get bright and dark circular rings with the point of contact as the centre.

Theory of Newton's Rings

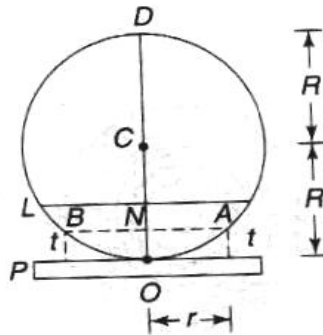

Fig. Theory of Newton's rings

To find the diameters of dark and bright rings, let 'L' be a lens placed on a glass plate P. The convex surface of the lens is the part of spherical surface (Fig.) with center at 'C'. Let R be the radius of curvature and r be the radius of Newton's ring corresponding to the film thickness 't'.

From the property of a circle, $NA \times NB = NO \times ND$

Substituting the values, $r \times r = t \times (2R-t)$

$$r^2 = 2Rt - t^2$$

As 't' is small, t^2 will be negligible

$$r^2 = 2Rt$$

$$t = \frac{r^2}{2R}$$

For bright ring, the condition is

$$2t = (2n-1)\frac{\lambda}{2}$$

$$2\frac{r^2}{2R} = (2n-1)\frac{\lambda}{2}$$

$$r^2 = \frac{(2n-1)\lambda R}{2}$$

Replacing r by $\frac{D}{2}$, the diameter of n^{th} bright ring will be

$$\frac{D^2}{4} = \frac{(2n-1)\lambda R}{2}$$

$$D = \sqrt{2n-1} \sqrt{2\lambda R}$$

$$D \propto \sqrt{2n-1}$$

$$D \propto \sqrt{\text{odd natural number}}$$

Thus, the diameters of the bright rings are proportional to the square root of odd natural numbers.

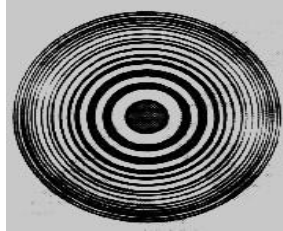

Fig: Newton's ring pattern

For dark ring, the condition is

$$2t = n\lambda$$

$$2\frac{r^2}{2R} = n\lambda$$

$$r^2 = n\lambda R$$

$$D^2 = 4n\lambda R$$

$$D = 2\sqrt{n\lambda R}$$

$$D \propto \sqrt{n}$$

$$D \propto \sqrt{\text{natural number}}$$

Thus, the diameters of dark rings are proportional to the square root of natural numbers.

With the increase in the order (n), the rings get closer and the fringe width decreases and are shown in Fig 7.5.

Determination of Wavelength of a Light Source

Let R be the radius of curvature of a Plano-convex lens, λ be the wavelength of light used. Let D_m and D_n are the diameters of m^{th} and n^{th} dark rings respectively. Then

$$D_m^2 = 4m\lambda R$$

$$\text{And } D_n^2 = 4(n)\lambda R$$

$$D_n^2 - D_m^2 = 4(m-n)\lambda R$$

$$\lambda = \frac{D_n^2 - D_m^2}{4(m-n)R}$$

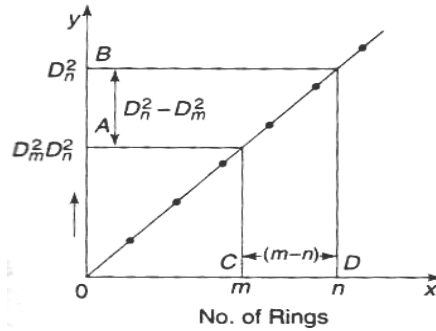

Fig Plot of D^2 with respect to number of rings

Newton's rings are formed with suitable experimental setup. With the help of travelling microscope, the readings for different orders of dark rings were noted from one edge of the rings to the other edge. The diameters of different orders of the rings can be known. A plot between D^2 and the number of rings gives a straight line as shown in the fig.

From the graph,

$$\frac{D_n^2 - D_m^2}{(m-n)} = \frac{AB}{CD}$$

The radius R of the Plano-convex lens can be obtained with the help of a Spectrometer. Substituting these values in the formula, λ can be calculated.

Determination of Refractive Index of a Liquid

The experiment is performed when there is an air film between glass plate and the Plano-convex lens. The diameters of m^{th} and n^{th} dark rings are determined with the help of travelling microscope. We have

$$D_n^2 - D_m^2 = 4(m-n) \lambda R \quad \rightarrow(8)$$

The system is placed into the container which consists of the liquid whose refractive index (μ) is to be determined. Now, the air film is replaced by the liquid film. Again, the diameters of the same m^{th} and n^{th} dark rings are to be obtained. Then we have

$$D_n'^2 - D_m'^2 = \frac{4(m-n) \lambda R}{\mu} \quad \rightarrow(9)$$

$$\mu = \frac{D_n^2 - D_m^2}{D_n'^2 - D_m'^2} \quad \rightarrow(10)$$

Using the above formula, ' μ ' can be calculated.

Michelson Interferometer:

In Michelson interferometer the two coherent sources are derived from the principle of division of amplitude. The parallel light rays from a monochromatic source are incident on beams splitter (glass plate) G_1 which is semi silvered on its back surface and mounted at 45° to the axis. Light ray incident ' O ' is refracted into the glass plate and reaches point A , where where it is partially reflected (ray 1) and partially transmitted ray 2. These rays then fall normally on mirrors M_1 (movable) and M_2 (fixed) and are

reflected back. These reflected rays reunite at point A again and follow path AT. Since these two rays are derived from same source (at A) and are therefore coherent, can interfere and form interference pattern.

In this geometry, the reflected ray 1, travels an extra optical path, a compensating plate G_2 of same thickness as plate G_1) is inserted in the path of ray 2 such that G_2 is parallel to G_1 . This introduces the same optical path in glass medium for ray 2 as ray 1 travels in plate G_1 (therefore is called a compensating plate). Any optical path difference between the ray 1 and ray 2 is now equal to actual path difference between them.

To understand, how the fringes are formed, refer to fig. An observer at 'T' will see the images of mirror M_2 and source S (M_2 and S' respectively) through beam splitter along with the mirror M_1 . S_1 and S_2 are the images of source in mirrors M_1 and M_2 respectively. The position of these elements in figure depends upon their relative distances from point A.

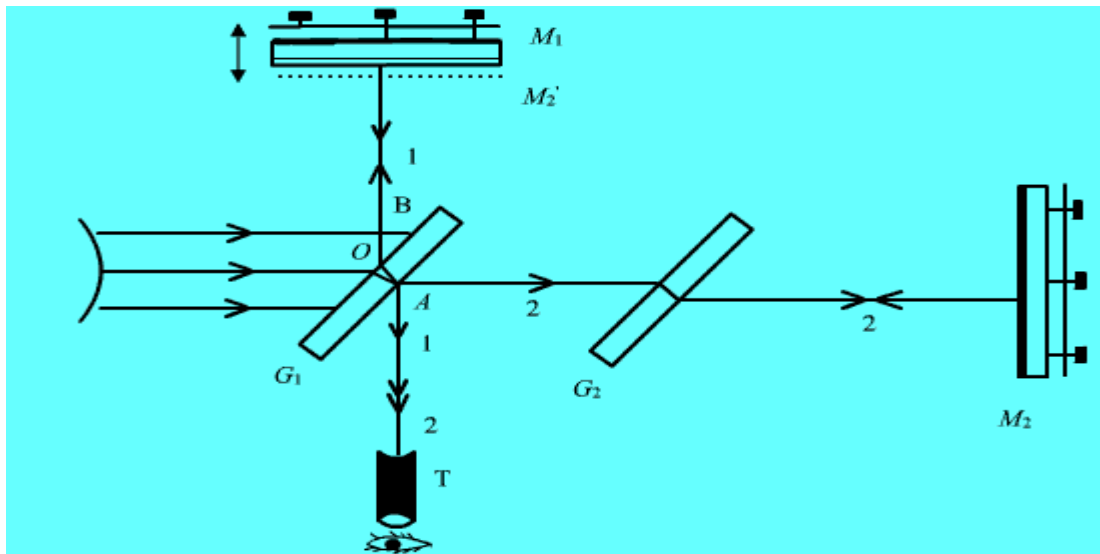

Fig. Michelson Interferometer (Experimental Set-up)

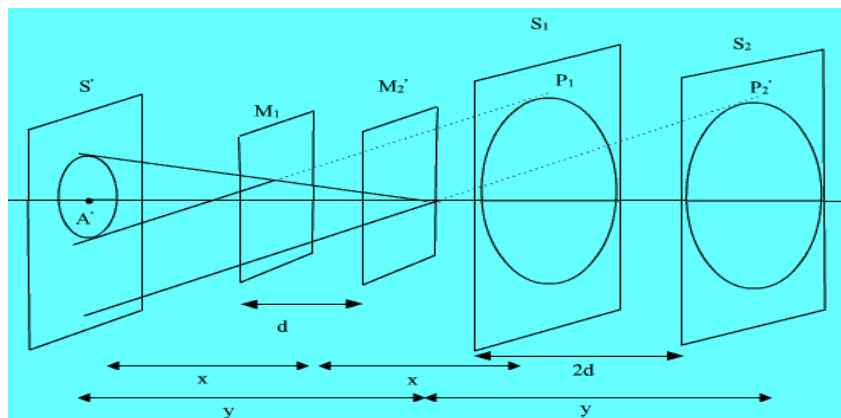

Fig. Formation of Fringes

Light from a point (say P) from extended source appears to come from corresponding coherent points P_1 and P_2 on S_1 and S_2 .

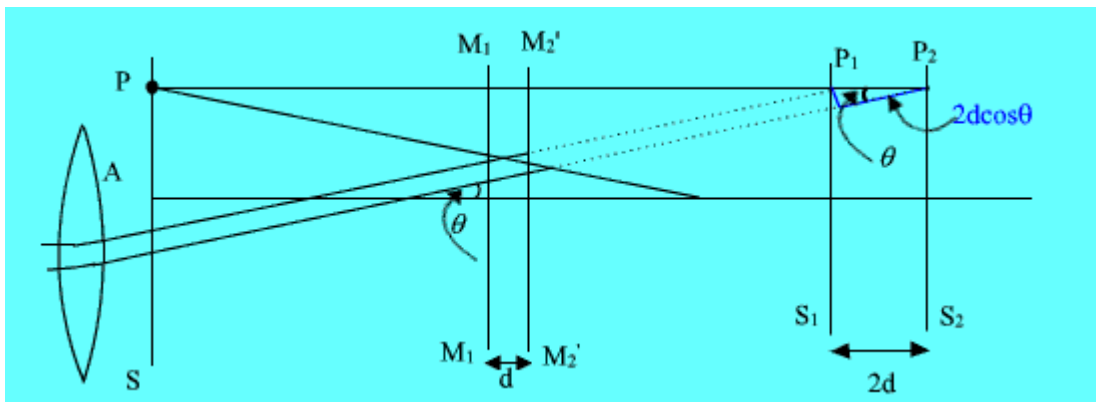

Fig.

If ' d ' is the separation between mirrors M_1 and M_2' then ' $2d$ ' is the separation between virtual sources S_1 and S_2 . The path difference between the two parallel rays coming from point P_1 and P_2 respectively and reaching the eyepiece is equal to $2d \cos \theta$

$$2d \cos \theta = n\lambda \text{ (Bright)}$$

$$2d \cos \theta = (2n + 1) \frac{\lambda}{2} \text{ (dark)}$$

These fringes are concentric rings or straight line depending upon the mutual inclination of mirrors M_1 and M_2 (M_2'). If mirrors M_1 and M_2 are parallel to each other the case similar to the air film between two parallel plate and fringes formed are concentric rings.

Michelson interferometer is used to determine the wavelength of monochromatic source, the difference between two wavelengths, determination of thickness/refractive index of thin transparent sheet.

Introduction to Diffraction

The wave nature of light is further confirmed by the optical phenomenon of diffraction. The word 'diffraction' is derived from the Latin word *diffraction* which means to break to pieces. It is common experience that waves bend around obstacles placed in their path. When light waves encounter an obstacle, they bend round the edges of the obstacle. This bending is predominant when the size of the obstacle is comparable to the wavelength of light. The bending of light waves around the edge of an obstacle is diffraction. It was first observed by Gremaldy.

DIFFRACTION

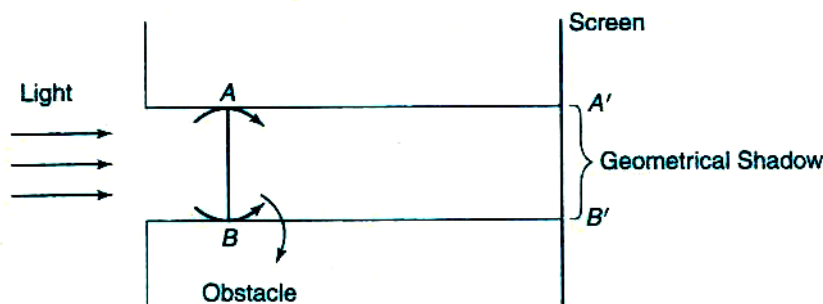

Fig Diffraction

As shown in fig., when light falls on an obstacle, the corresponding geometrical shadow on the screen should be completely dark. In practice, the geometrical shadow consists of bright and dark fringes. These fringes are due to the superimposition of bended light waves around the corners of an obstacle. The amount of bending depends upon the size of the obstacle and wavelength of light.

When the light falls on an obstacle whose size is comparable with the wavelength of light, then the light bends around the edges or corners of the obstacle and enters into the geometrical shadow. This bending of light is known as diffraction. The bright and dark fringes in the shadow form a diffraction pattern.

The diffraction phenomena are broadly classified into two types:

Fresnel diffraction

To study diffraction, there should be a light source, obstacle and screen. In this class of diffraction, the source and screen are placed at finite distances from the obstacle. To study this diffraction, lenses are not necessary as the source and screen are at a finite distance. This diffraction can be studied in the direction of propagation of light. The incident wave fronts are either spherical or cylindrical.

Fraunhofer diffraction

In this class of diffraction, the source and screen are placed at infinite distances from the obstacle. Due to the above fact, lenses are needed to study the diffraction. This diffraction can be studied in any direction. In this case, the incident wave front is plane.

Fraunhofer Diffraction at Single Slit

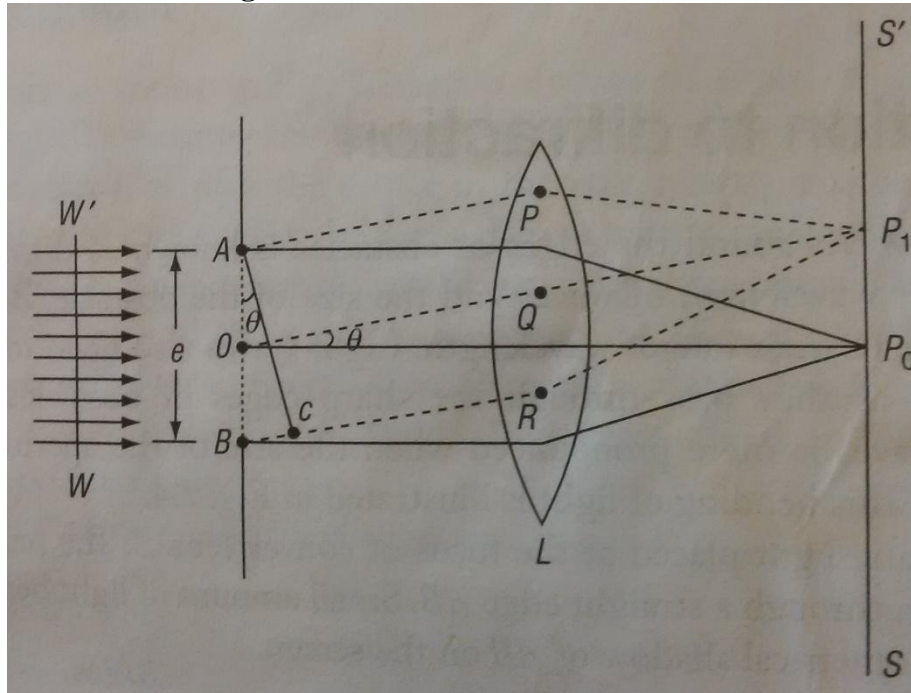

Fig. 1 Fraunhofer diffraction at single slit

Consider the width of the slit AB is equal to “e”. Let a plane wave front WW' of monochromatic light of wavelength λ propagating normally towards the slit is incident on the slit AB. The diffracted light through the slit is focused by means of a convex lens on a screen placed in the focal plane of the lens. Every point on the wave front in the slit will act as a source of secondary wavelets. The secondary wavelets travelling in the direction of OP_0 are brought to focus at P_0 on the screen SS' by using a converging lens L. The secondary wavelets from AB which are brought to focus at P_0 have no path difference. Hence the intensity at P_0 is high and it is known as central maximum. The secondary wavelets in the slit AB which make an angle ' θ ' with OP_0 direction are brought to a point P_1 on the screen.

Intensity at point P_1 depends on the path difference between the wavelets at A and at B reaching to point P_1 . To find the path difference, a perpendicular AC is drawn from A to BR from A.

Now the path difference between the secondary wavelets from A and B in the direction of OP_1 is BC.

$$\text{Path difference} = BC = AB \sin \theta = e \sin \theta$$

$$\text{Corresponding phase difference} = \frac{2\pi}{\lambda} \times \text{path difference} = \frac{2\pi}{\lambda} \times e \sin \theta$$

Let the width of the slit be divided into 'n' equal parts and the amplitude of the wave from each part is 'a'. The phase difference between any two successive waves from these parts would be

$$\frac{1}{n} [\text{total phase}] = \frac{1}{n} \left[\frac{2\pi}{\lambda} e \sin \theta \right] = d \text{ (say)}$$

Using the method of vector addition of amplitudes, the resultant amplitude R is given by

$$\begin{aligned} R &= \frac{a \sin nd/2}{\sin d/2} \\ &= \frac{a \sin (\pi e \sin \frac{\theta}{\lambda})}{\sin (\pi e \sin \frac{\theta}{n\lambda})} \\ &= a \frac{\sin \alpha}{\sin \alpha/n} \\ &= na \frac{\sin \alpha}{\alpha} \quad (\text{i.e. } na = A) \end{aligned}$$

$$R = A \frac{\sin \alpha}{\alpha}$$

$$\text{Intensity} = I = R^2 = A^2 \left(\frac{\sin \alpha}{\alpha} \right)^2 \dots\dots\dots (1)$$

Principal maximum:

The resultant amplitude R can be written in ascending powers of α as

$$R = A \left[\alpha - \frac{\alpha^2}{3!} + \frac{\alpha^4}{5!} - \frac{\alpha^6}{7!} + \dots \right]$$

I will be maximum, when the value of R is maximum. For maximum value of R, the negative terms must vanish, i.e., $\alpha = 0$

$$\begin{aligned} \frac{\pi e \sin \theta}{\lambda} &= 0 \\ \sin \theta &= 0 \\ \theta &= 0 \quad \dots\dots\dots (2) \end{aligned}$$

$$\begin{aligned} \text{Then, } R &= A \\ I_{\text{max}} &= R^2 = A^2 \quad \dots\dots\dots (3) \end{aligned}$$

The condition $\theta = 0$ means that the maximum intensity is formed at P_0 and is known as principal maximum.

Minimum Intensity

I will be minimum, when $\sin \alpha = 0$

$$\begin{aligned} \alpha &= \pm \pi, \pm 2\pi, \pm 3\pi \\ \alpha &= \pm m\pi \\ \frac{\pi e \sin \theta}{\lambda} &= \pm m\pi \\ e \sin \theta &= \pm m\lambda \dots \dots \dots (4) \end{aligned}$$

where $m = 1, 2, 3, \dots$

Thus, we obtain the points of minimum intensity on either side of the principal maximum. For $m = 0$, $\sin \theta = 0$, which corresponds to principal maximum.

Secondary maxima:

In between the minima, we get secondary maxima. The positions can be obtained by differentiating the expression of I w.r.t. α and equating to zero. We get

$$\frac{dI}{d\alpha} = \frac{d}{d\alpha} [A^2 (\frac{\sin \alpha}{\alpha})^2] = 0$$

$$A^2 [\frac{2\sin \alpha}{\alpha} \cdot \frac{\alpha \cos \alpha - \sin \alpha}{\alpha^2}] = 0$$

Either $\sin \alpha = 0$ or $\alpha \cos \alpha - \sin \alpha = 0$

$\sin \alpha = 0$ gives positions of minima.

Hence the positions of secondary maxima are given by $\alpha \cos \alpha - \sin \alpha = 0$

$$\alpha = \tan \alpha \dots \dots \dots (5)$$

The values of α satisfying the above equation are obtained graphically by plotting the curves $y = \alpha$ and $y = \tan \alpha$ on the same graph. The points of intersection of the two curves give the values of α , which satisfy the above equation. The plots of $y = \alpha$ and $y = \tan \alpha$ are shown in Fig. 2

Fig. 2 Plots of $y = \alpha$ and $y = \tan \alpha$

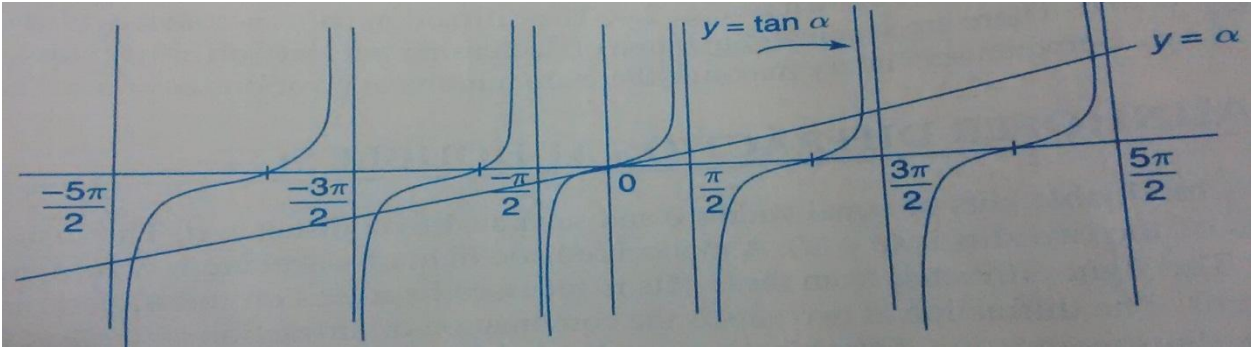

The points of intersections are $\alpha = 0, \pm \frac{3\pi}{2}, \pm \frac{5\pi}{2}, \dots$
 substituting the above values in equation (1), we get the intensities in various maxima.

$$\begin{aligned} \alpha = 0, I_0 &= A^2 && \text{(Principal maximum)} \\ \alpha = \frac{3\pi}{2}, I_0 &= A^2 \left[\frac{\sin 3\pi/2}{3\pi/2} \right]^2 \approx \frac{A^2}{22} \text{(1st secondary maximum)} \\ \alpha = \frac{5\pi}{2}, I_0 &= A^2 \left[\frac{\sin 5\pi/2}{5\pi/2} \right]^2 \approx \frac{A^2}{62} \text{(2nd secondary maximum)} \end{aligned}$$

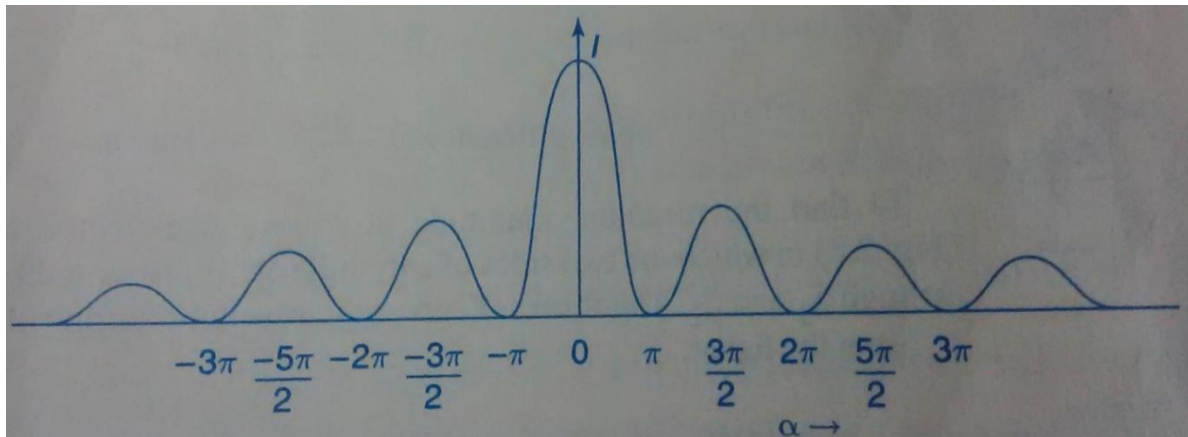
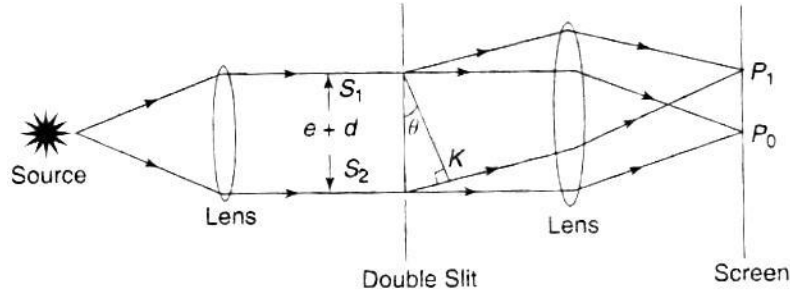

Fig. 3 Intensity distribution of diffraction due to single slit

Fraunhofer Diffraction at Double Slit

Let S_1 and S_2 be double slits of equal widths e and separated by a distance d . The distance between the middle points of the two slits is $(e + d)$. A monochromatic light of wave length λ is incident normally on the two slits. The light diffracted from these slits is focused by a lens on the screen placed in the focal plane of the lens. The diffraction at two slits is the combination of diffraction as well as interference, i.e., the pattern on the screen is the diffraction pattern due to a single slit on which a system of interference fringes is superimposed. When a plane wave front is incident normally on two slits, the secondary wavelets from the slits travel uniformly in all directions. The wavelets travelling in the direction of incident light come to a focus at P_0 while the wavelets travelling in a direction making an angle θ , come to focus at P_1 .



Fraunhofer diffraction-double slit

From the study of diffraction due to single slit, the resultant amplitude = $\frac{A \sin \alpha}{\alpha}$

Where,

$$\alpha = \frac{\pi e \sin \theta}{\lambda}$$

Since a double slit is used, from each slit a wavelet of amplitude $\frac{A \sin \alpha}{\alpha}$ in a direction θ is obtained. These two wavelets interfere and meet at a point P_1 on the screen. To calculate the path difference between the wavelets, draw a normal S_1K to the wavelet through S_2 .

$$\begin{aligned} \text{Path difference} &= S_2K \\ &= (e + d) \sin \theta \\ \text{Phase difference } \delta &= \frac{2\pi}{\lambda} (e + d) \sin \theta \rightarrow (6) \end{aligned}$$

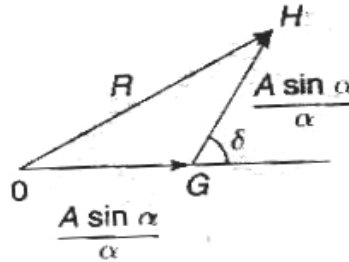

Vector addition method

To find the resultant amplitude at P_1 vector addition method is used. (Fig. 7.12) in which the two sides of a triangle are represented by the amplitudes through S_1 and S_2 . The third side gives the resultant amplitude.

From the figure,

$$\begin{aligned} (OH)^2 &= (OG)^2 + (GH)^2 + 2 (OG)(GH) \cos \delta \\ R^2 &= \left[\frac{A \sin \alpha}{\alpha} \right]^2 + \left[\frac{A \sin \alpha}{\alpha} \right]^2 + 2 \left[\frac{A \sin \alpha}{\alpha} \right] \left[\frac{A \sin \alpha}{\alpha} \right] \cos \delta \\ &= A^2 \frac{\sin^2 \alpha}{\alpha} [2 + 2 \cos \delta] \\ &= 2 \left[\frac{A \sin \alpha}{\alpha} \right]^2 (1 + \cos \delta) \end{aligned}$$

$$\begin{aligned}
&= 2 \left[\frac{A \sin \alpha}{\alpha} \right]^2 (1 + 2 \cos^2 \delta/2 - 1) \\
&= 4 \left[\frac{A \sin \alpha}{\alpha} \right]^2 \cos^2 \delta/2 \\
R^2 &= 4A^2 \left[\frac{\sin \alpha}{\alpha} \right]^2 \cos^2 \left[\frac{\pi(e+d) \sin \theta}{\lambda} \right] \\
&\quad \text{Let } \beta = \frac{\pi(e+d) \sin \theta}{\lambda}
\end{aligned}$$

$$R^2 = 4A^2 \left[\frac{\sin \alpha}{\alpha} \right]^2 \cos^2 \beta$$

The resultant intensity $I = R^2 = 4A^2 \left[\frac{\sin \alpha}{\alpha} \right]^2 \cos^2 \beta \rightarrow (7)$

From the above expression, it is clear that the resultant intensity is the product of two factors, i.e.,

1. $A^2 \left[\frac{\sin \alpha}{\alpha} \right]^2$ which represents the diffraction pattern due to a single slit
2. $\cos^2 \beta$, which gives the interference pattern due to wavelets from double slits. The resultant intensity is due to both diffraction and interference effects.

Diffraction Effect

The diffraction term $A^2 \left[\frac{\sin \alpha}{\alpha} \right]^2$ gives the principal maximum as the centre of the screen with alternate minima and secondary maxima of decreasing intensity. We get principal maximum for $\theta = 0$. We get minima for $\sin \alpha = 0$

$$\alpha = \pm m\pi, \text{ where } m = 1, 2, 3 \dots$$

$$\frac{\pi e \sin \theta}{\lambda} = \pm m\pi$$

$$e \sin \theta = \pm m\lambda$$

The positions of secondary maxima occur for

$$\alpha = \frac{\pm 3\pi}{2}, \frac{\pm 5\pi}{2}, \frac{\pm 7\pi}{2} \dots$$

Interference Effect

The interference term $\cos^2 \beta$ gives the equidistant bright and dark fringes.

The maxima will occur for $\cos^2 \beta = 1$

$$\beta = \pm n\pi, \text{ where } n = 0, 1, 2, 3 \dots$$

$$\beta = 0, \pm \pi, \pm 2\pi, \pm 3\pi \dots$$

$$\frac{\pi(e+d) \sin \theta}{\lambda} = \pm n\pi$$

$$(e + d) \sin \theta = \pm n\lambda$$

The minima will occur for $\cos^2\beta = 0$

$$\beta = \pm (2n + 1) \frac{\pi}{2} \quad \text{where } n = 0, 1, 2, 3 \dots$$

$$(e+d) \sin\theta = \pm(2n + 1) \frac{\lambda}{2}$$

Intensity Distribution

Figure 7.13 (a) and (b) represents the intensity variations due to diffractions as well as interference effect individually. When both effects are combined then the resultant intensity variation is obtained. From the figure it is clear that the resultant minima are not equal to zero, still they have some minimum intensity due to interference effect.

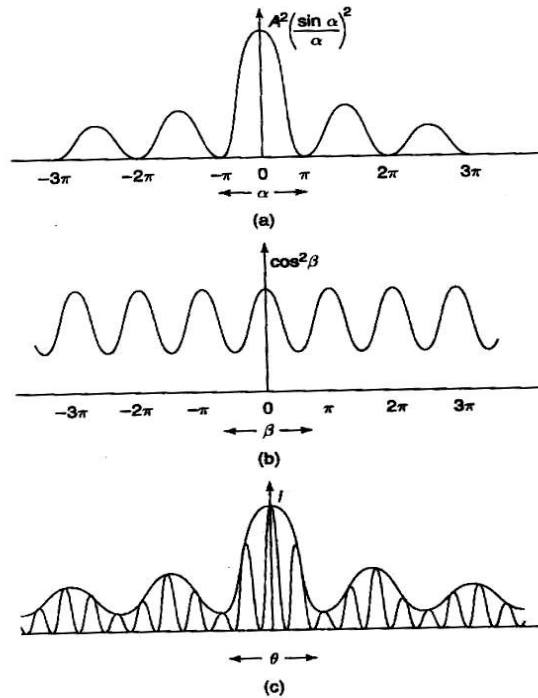

(a) Diffraction effect (b) Interference effect (c) Resultant intensity

4. Discuss the Fraunhofer diffraction due to a N-slits and obtain the intensity distribution and positions of maxima and minima.

(or)

Give the construction and theory of a plane diffraction grating of the transmission type and explain the formation of spectra by it.

Ans.

Construction:

An arrangement which consists of a large number of parallel slits of the same width and separated by equal opaque spaces is known as diffraction grating. Fraunhofer used the first

grating consisting of a large number of parallel wires placed side by side very closely side by side at regular intervals. The diameters of the wires were of the order of 0.05 mm diameter and their spacing, varied from 0.0533 mm to 0.687 mm. Now gratings are constructed by ruling equidistant parallel lines on a transparent material such as glass, with a fine diamond point. Usually 15,000 lines are drawn on one-inch width of the grating. The ruled lines are opaque to light while the space between any two lines is transparent to light and acts as a slit. This is known as plane transmission grating.

Theory:

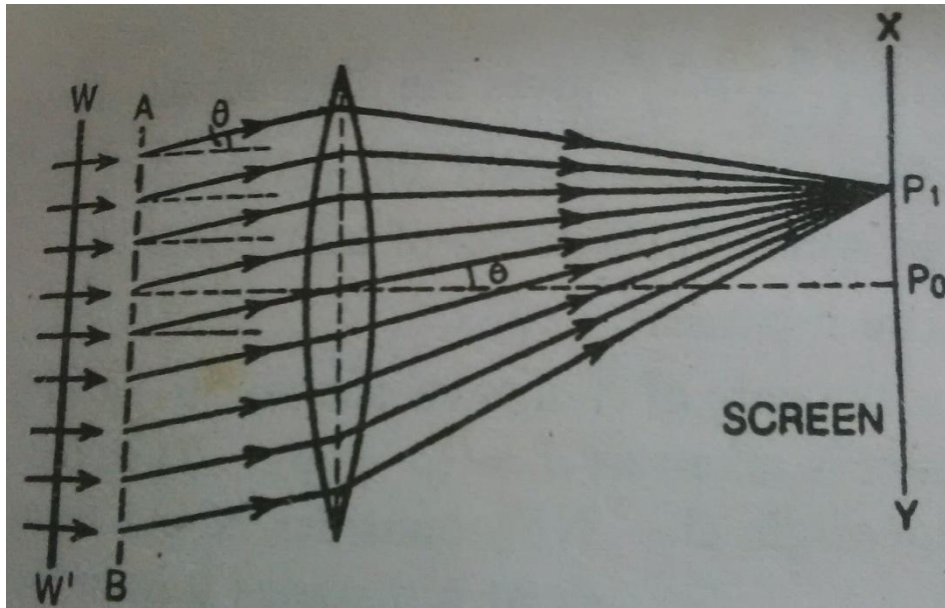

Fig. 1 Diffraction grating

Fig. 1, represents the section of a plane transmission grating placed perpendicular to the plane of the paper. Let 'e' be the width of each slit and these slits are separated by equal opaque regions part of each width 'd'. Then (e +d) is known as grating element. XY is the screen placed perpendicular to the plane of a paper. Suppose a parallel beam of monochromatic light of wavelength λ be incident normally on the grating. By Huygen's principle, each of the slit sends secondary wavelets in all directions. The secondary wavelets travelling in the same direction of incident light will come to a focus at a point P₁ of the screen as the screen is placed at the focal plane of the convex lens. The point P₀ will be a central maximum. Now consider the secondary waves travelling in a direction inclined at an angle θ with the direction of the incident light. These waves reach point P₁ on passing through the convex lens in different phases. As a result, dark and bright bands on both sides of central maximum are obtained.

The intensity at point P₁ may be considered by applying the theory of Fraunhofer diffraction at a single slit. The resultant amplitude due to diffraction at single slit is $\frac{A \sin \alpha}{\alpha}$, which is now at the middle point of each slit where, $\alpha = \pi e \sin\theta/\lambda$. Let us assume that there are N

slits on the grating. The path difference between the corresponding points is $(e + d) \sin \theta$ and in terms of phase difference it is $\frac{2\pi}{\lambda}(e + b) \sin \theta = 2\beta$. The resultant of N amplitudes, each of $\frac{A \sin \alpha}{\alpha}$ with common phase difference (2β) between consecutive diffracted amplitudes can be obtained by the vector addition method. The resultant amplitude (R) of the N amplitudes each of $\frac{A \sin \alpha}{\alpha}$ is

$$R = \frac{A \sin \alpha}{\alpha} \cdot \frac{\sin N\beta}{\sin \beta} \quad (1)$$

and intensity

$$I = R^2 = \left(\frac{A \sin \alpha}{\alpha}\right)^2 \left(\frac{\sin N\beta}{\sin \beta}\right)^2 \quad (2)$$

The value $\left(\frac{A \sin \alpha}{\alpha}\right)^2$ shows the intensity distribution due to single slit diffraction and $\sin^2 N\beta / \sin^2 \beta$ shows the combined intensity distribution due interference at all the N slits.

Discussion of intensity distribution:

Principal maxima:

From equation (2), we know that the intensity would be maximum when $\sin \beta = 0$, where $\beta = 0, \pi, 2\pi, 3\pi, \dots = n\pi$ and $n = 0, 1, 2, 3, \dots$

$$\text{Then } \frac{\sin N\beta}{\sin \beta} = \frac{0}{0}$$

The above factor is indeterminate; To find its value, the numerator and denominator are differentiated separately. i.e., by applying the Hospital's rule. Thus

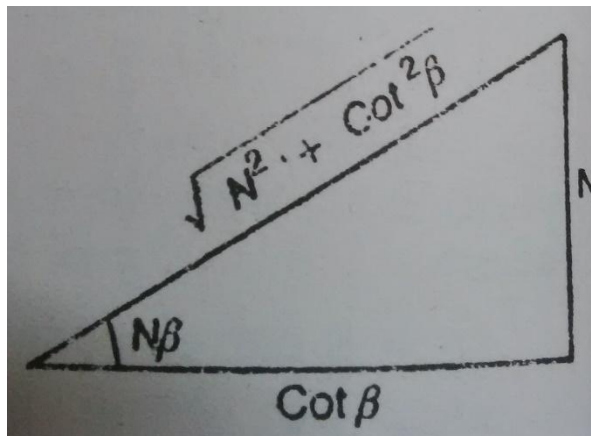

Fig. 2

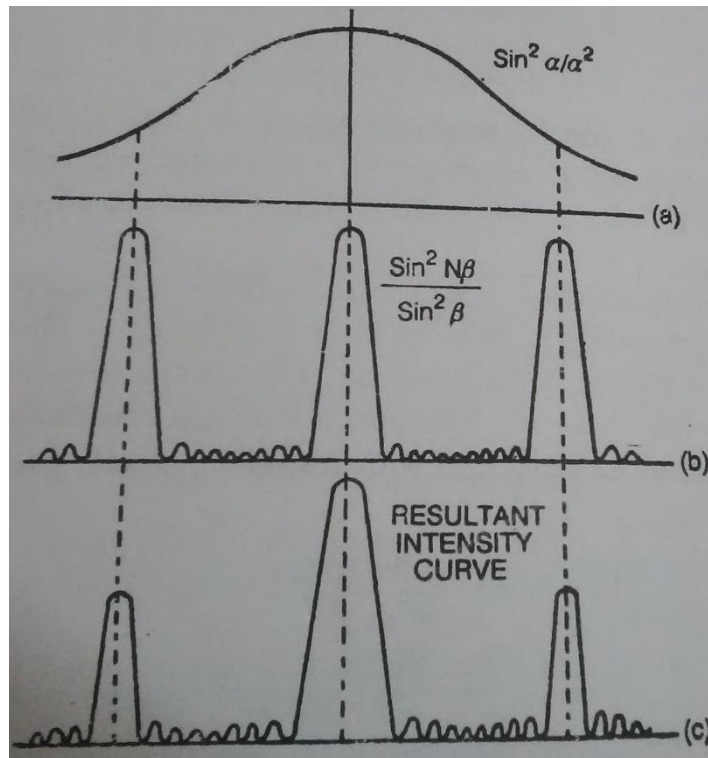

Fig. 3(a) the variation of intensity due to the factor $\text{sin}^2 \alpha/\alpha^2$ is represented; **(b)** the variation of intensity due to the factor $\text{sin}^2 N\beta/\text{sin}^2 \beta$ is represented and **(c)** the resultant variation of intensity is represented.

Diffraction Grating

An arrangement which consists of a large number of parallel slits of the same width and separated by equal opaque spaces is known as diffraction grating. Fraunhofer used the first grating consisting of a large number of parallel wires placed side by side very closely at regular intervals. Now gratings are constructed by ruling equidistant parallel lines on a transparent material such as glass with a fine diamond point. The ruled lines are opaque to light while the space between any two lines is transparent to light and acts as a slit.

Commercial gratings are produced by taking the cast of an actual grating on a transparent film like that of cellulose acetate. Solution of cellulose acetate is poured on the ruled surface and allowed to dry to form a thin film, detachable from the surface. These impressions of a grating are preserved by mounting the film between two glass sheets.

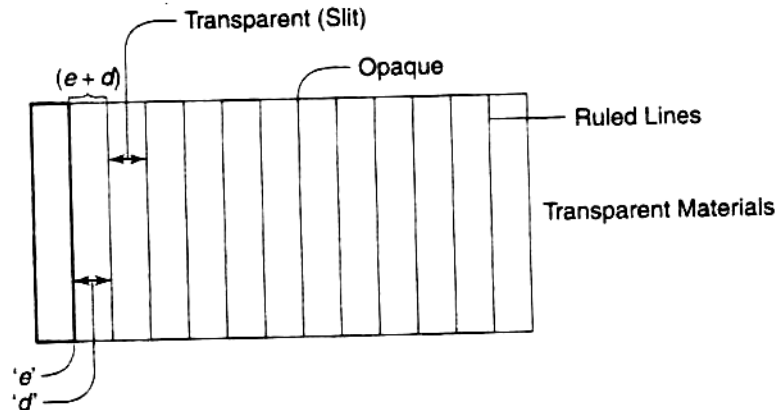

Fig7.17 Diffraction Grating

Let 'e' be the width of the line and 'd' be the width of the slit. Then (e+d) is known as *grating element*. If 'N' is the number of lines per inch on the grating, then

$$N(e+d) = 1'' = 2.54 \text{ cm}$$

$$e+d = \frac{2.54}{N} \text{ cm}$$

There will be nearly 30,000 lines per inch of a grating. Due to the above fact, the width of the slit is very narrow and is comparable to the wavelength of light. When light falls on the grating, the light gets diffracted through each slit. As a result, both diffraction and interference of diffracted light gets enhanced and forms a diffraction pattern. This pattern is known as *diffraction spectrum*.

Grating Spectrum

The condition to form the principal maxima in a grating is given by

$$(e+d) \sin \theta = n\lambda$$

Where (e+d) is the grating element and the above equation is known as grating equation.

From the grating equation, the following is clear.

1. For a particular wavelength λ , the angle of diffraction θ is different for principal maxima of different orders.
2. As the number of lines in the grating is large, maxima appear as sharp, bright parallel lines and are termed as spectral lines.
3. For white light and for a particular order of n, the light of different wavelengths will be diffracted in different directions.
4. At the center, $\theta=0$ gives the maxima of all wavelengths which coincides to form the central image of the same color as that of the light source. This forms zero order. (Fig.2.9)
5. The principal maxima of all wavelengths forms the first, second, order spectra for $n=1,2,$
...
6. The longer the wavelength, greater is the angle of diffraction. Thus, the spectrum consists of violet being in the innermost position and red being in the outermost positions.

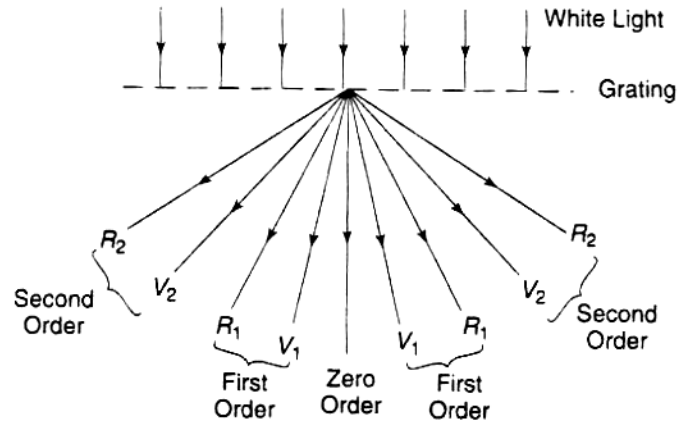

Fig7.18 Grating Spectrum

7. Most of the intensity goes to zero order and the rest is distributed among other orders.
8. Spectra of different orders are situated symmetrically on both sides of zero order.
9. The maximum number of orders available with the grating is $n_{\max} = \frac{(e+d)}{\lambda}$

MODULE-V

HARMONIC OSCILLATIONS AND WAVES IN ONE DIMENSION

Waves:

A wave is a disturbance of a medium which transfers energy from one place to another place without transport of matter. The medium for ocean waves is water, for example. When a string, fixed at both ends, is given a vertical hit by a stick, a dent appears in it that travels along the string. When it reaches an end point, it reflects and inverts and travels toward the other end. *Fig.1* shows the motion of a single disturbance.

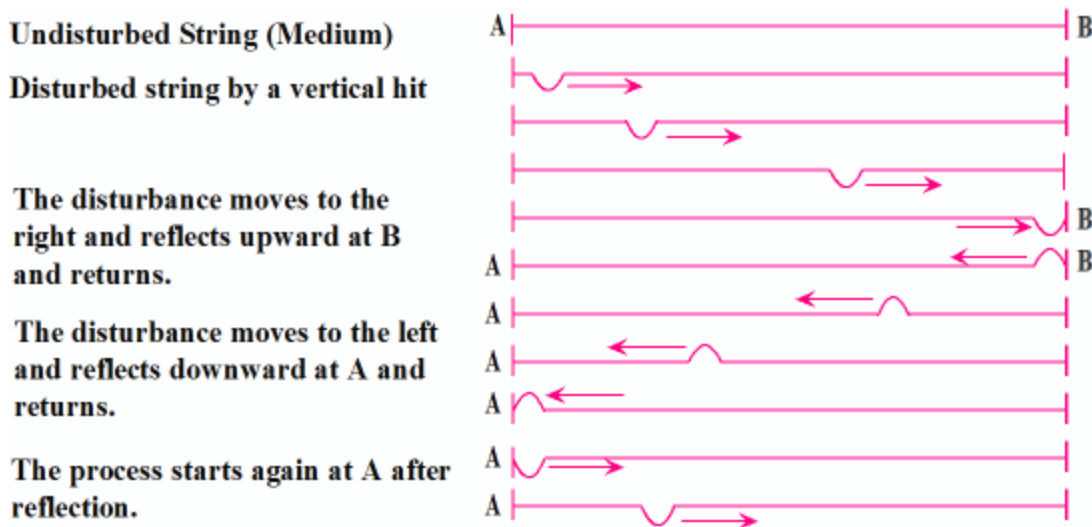

Figure 1

If you hold *end A* of the string (*Fig. 2*) and try to give it a continuous *up-and-down motion*, with a little adjustment of the pace of oscillations, you can make at least the following *waveforms*:

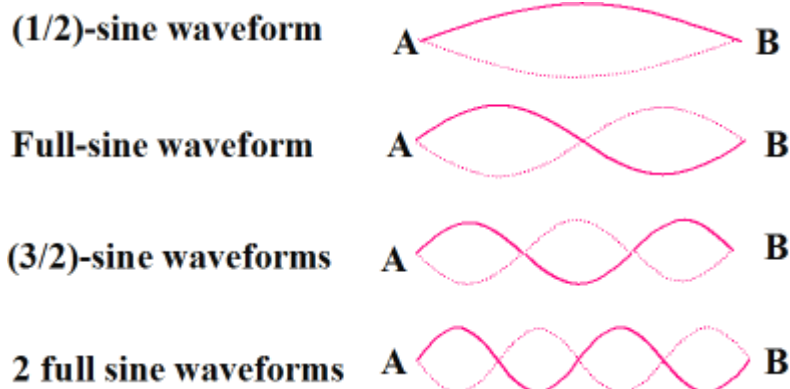

Figure 2

Each wave travels from *A* to *B* and reflects at *B*. When each reflected wave reaches point *A*, it reflects again and the process repeats. Of course, the up and down motion of hand keeps putting energy into the system by constantly generating waves that are in phase with the returned waves creating the above waveforms. Although the waves appear to be standing as they are called "*standing waves*," they are actually traveling back-and-forth along the string. The subject of waves is lengthy, complicated, and mathematically very involved. The above is enough to give you an idea.

Types of Waves:

There are two classifications: *one classification* of waves is: *mechanical and electromagnetic*.

Mechanical waves require *matter* for their transmission. Sound waves, ocean waves, and waves on a guitar string are examples. Air, water, and metal string are their media (matter), respectively.

Electromagnetic waves travel *both* in *vacuum and matter*. If light (an electromagnetic wave itself) could not travel in vacuum, we would not see the Sun. Radio waves, ultraviolet waves, and infrared waves are all electromagnetic waves and travel in vacuum.

Waves are also *classified* as *transverse* and *longitudinal* (See *Fig. 3*).

For a *transverse wave* the *disturbance direction is perpendicular to the propagation direction*. Water waves are transverse. Waves on guitar strings are also transverse.

For a *longitudinal wave* the *disturbance direction is parallel to the propagation direction*. Waves on a slinky as well as sound waves are longitudinal.

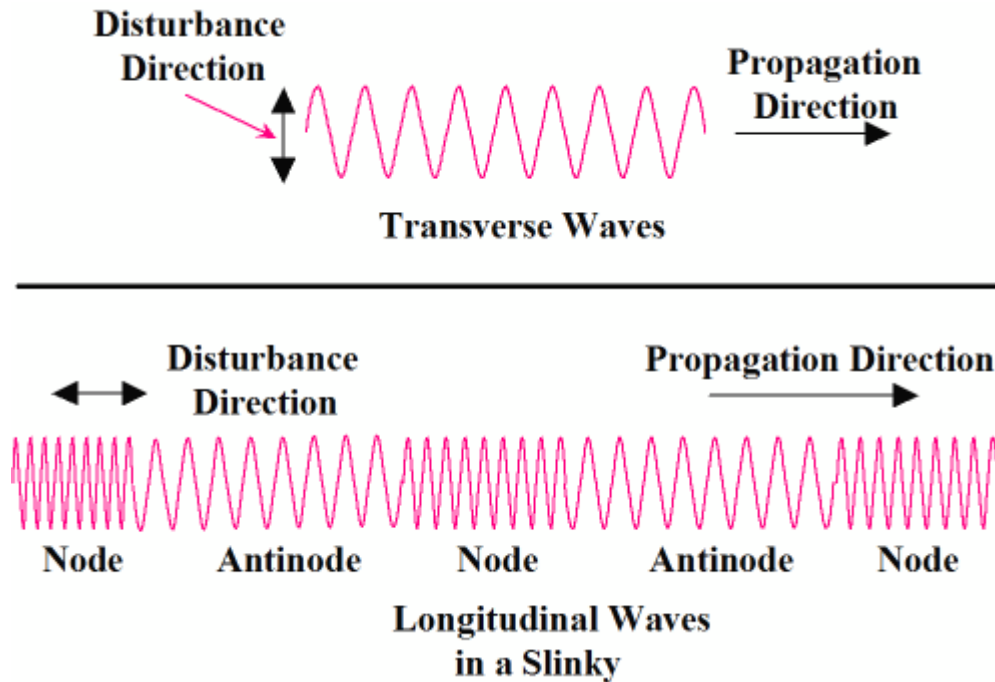

Figure 3

Frequency (f):

The *frequency f* of a wave is the *number of full waveforms generated per second*. This is the same as the number of repetitions per second or *the number of oscillations per second*. The *SI unit* for *frequency* is (1/s), or (s^{-1}), called "*Hertz (Hz)*."

Period (T):

Period T is the *number of seconds per waveform*, or the *number of seconds per oscillation*. It is clear that *frequency* and *period* are *reciprocals*.

$$T = 1/f$$

Also, recall the useful relation between frequency f and the angular speed ω :

$$\omega = 2\pi f.$$

ω is the number of *radians per second*, but f is the number of *turns or oscillations per second*. *Each turn is 2π radians*.

Wavelength (λ):

Wavelength λ is the distance between two successive points on a wave that are in the same state of oscillation. Points **A** and **B** in **Fig. 4** are the nearest or successive points that are both the same amount passed the maximum and therefore in the same state of oscillation.

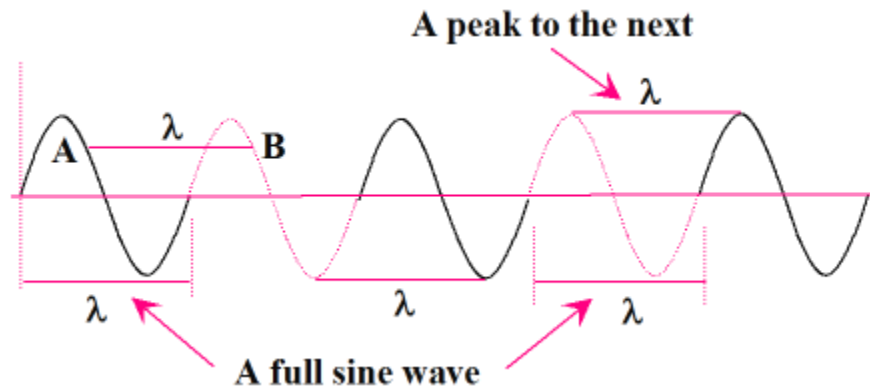
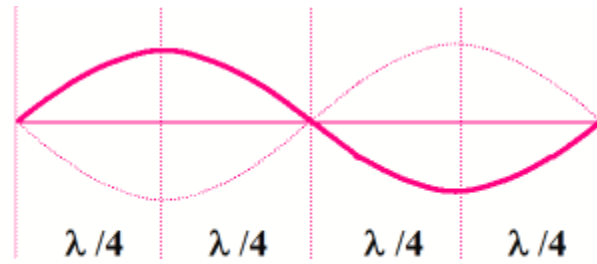

Figure 4

Wavelength may also be defined as *the distance between a peak to the next*, or the distance between a trough to the next, as shown **above**.

Also pay attention to **Fig. 5**. It shows that *the distance between any node and the anti-node next to it is $\lambda/4$* .



The distance between a node and the antinode next to it is $\lambda/4$

Figure 5

Wave Speed (v):

The wave speed is the distance a wave travels per second. A wave source with frequency f generates f wavelengths per second and since each wavelength is λ units long; therefore, the wave speed formula is:

$$v = f\lambda.$$

Example 1: The speed of sound waves at **STP condition** is 331m/s. Calculate the wavelength of a sound wave with a frequency of 1324Hz at **STP**.

Solution: $v = f \lambda$; $\lambda = v/f$; $\lambda = (331\text{m/s})/(1324/\text{s}) = 0.250\text{m}$.

The Vibrating String

A stretched string fixed at both ends and brought into oscillation forms a "**vibrating string**." An example is a violin string on which waves keep traveling back-and-forth between its ends. If a violin string is observed closely or by a magnifying glass, at times it appears as shown on the right.

The higher the pitch of the note it plays, the higher the frequency of oscillations and the shorter the wavelength or the sine-waves that appear along its length. The waveforms appear to be stationary, but in reality they are not. They are called "**standing waves**."

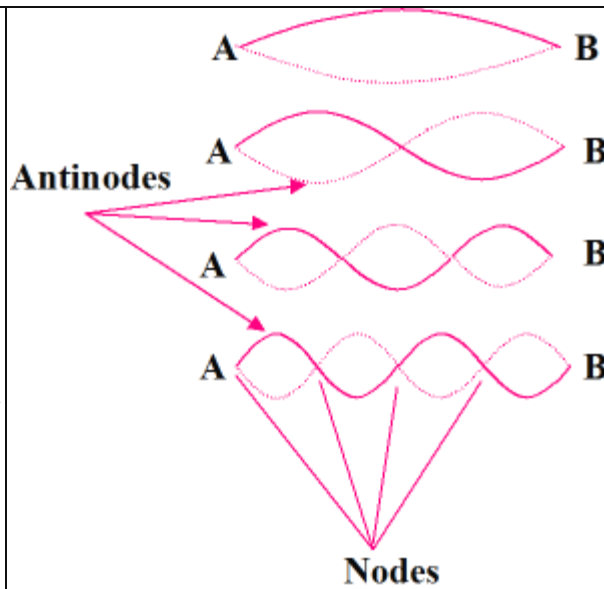

Figure 6

Nodes are points of zero oscillation and **antinodes** are points of maximum oscillation as shown in **Fig. 6**.

Now, look at the following example:

Example 2: In a 60.0-cm long violin string, three antinodes are observed. Find the wavelength of the waves on it.

Solution: Each loop has a length of $60.0\text{cm} / 3 = 20.0\text{cm}$.

Each wavelength (a full sine wave) contains two of such loops; therefore,

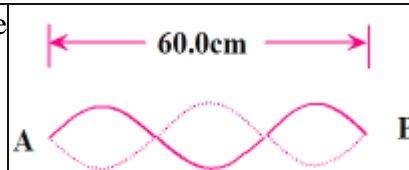

Fig. 7

$\lambda = 40.0\text{cm}$.

Speed of Waves in a Stretched String:

The speed of waves in a stretched string depends on the **tension F** in the string as well as the **mass per unit**

The formula that relates **tension F** in the string and the **waves speed v** is:

length μ of the string as explained below:

The more a string is stretched, the faster waves travel in it.

$$v = \sqrt{\frac{F}{\mu}} \quad \text{where } \mu = \frac{M}{L}$$

is mass per unit length of the string.

Proof:

If we model the peak of a wave as it passes through the medium (the string) at speed v as shown in **Fig. 8**, we may think that the peak segment is under a tensile force F that pulls it in opposite directions. The hump can be looked at as a portion of a circle from A to B with its center at C . The hump is being pulled down by a force of magnitude $2F\sin\theta$. This pulling down force passes through the center and therefore acts as a centripetal force for the segment that is equal to Mv^2/R ; therefore, $2F\sin\theta = Mv^2/R$. For small angles and in radians, $\sin\theta = \theta$. The formula becomes:

$$2F\theta = Mv^2/R \quad (1) \quad \text{where } M = \text{the mass of the string segment.}$$

<p>If we calculate <i>mass M of the hump</i>, it results in $M = 2\mu R\theta$.</p> <p>This is because the <i>length of the hump</i> is $2R\theta$ and μ is the mass per unit length of the string. In other words,</p> <p>$\mu = \text{mass / length}$. Eqn. (1) takes the form:</p> $2F\theta = 2\mu R\theta v^2/R \quad (2)$ <p>Solving for v results in:</p>	 $v = \sqrt{\frac{F}{\mu}} \quad \text{where } \mu = \frac{M}{L}$ <p>is mass per unit length of the string.</p>
--	--

Figure 8

Example : A 120-cm guitar string is under a tension of 400N. The mass of the string is 0.480 grams. Calculate (a) the mass per unit length of the string and (b) the speed of waves in it. (c) In a diagram show the number of $(1/2)\lambda$'s that appear in this string if it is oscillating at a frequency of 2083Hz.

Solution: (a) $\mu = M/L$; $\mu = 0.480 \times 10^{-3} \text{ kg} / 1.20 \text{ m} = 4.00 \times 10^{-4} \text{ kg/m}$.

(b) $v = (F/\mu)^{1/2}$; $v = [400 \text{ N} / 4.00 \times 10^{-4} \text{ kg/m}]^{1/2} = 1000 \text{ m/s}$.

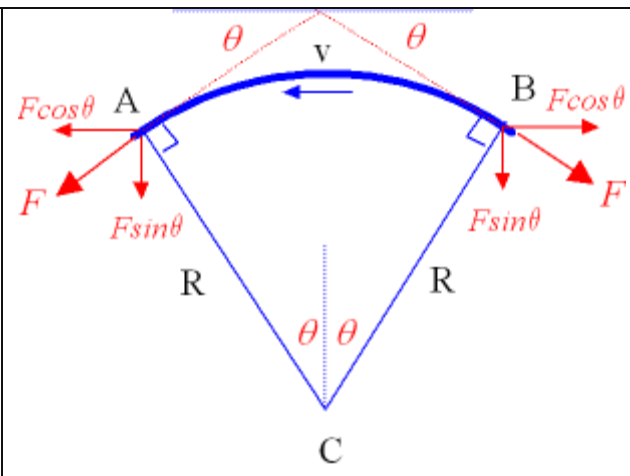
(c) $v = f \lambda$; $\lambda = v/f$; $\lambda = (1000 \text{ m/s}) / (2083 \text{ /s}) = 0.480 \text{ m}$.

$(1/2)\lambda = 0.480 \text{ m} / 2 = 0.240 \text{ m}$.

The number of $(\lambda/2)$'s that fit in this string length of 120cm is

$1.20 \text{ m} / 0.240 \text{ m} = 5.00$, as shown in *Fig. 8*.

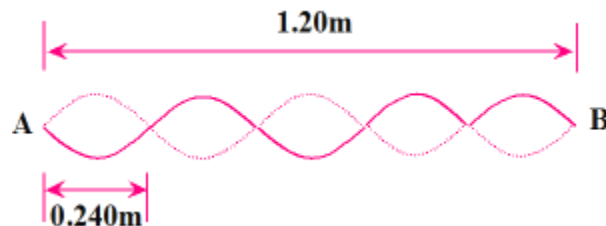

Figure 9

Traveling Harmonic Waves:

We are interested in finding a formula that calculates the *y-value* at any point in a one dimensional medium as harmonic waves travel in it at speed v . This means that *at any point x and at any instant t*, we want $y(x,t)$. For harmonic waves, such equation has the general form:

$$y(x,t) = A \sin(kx - \omega t + \phi)$$

$$\text{where } k = \frac{2\pi}{\lambda}, \quad \omega = \frac{2\pi}{T},$$

$$v = f \lambda, \quad \text{and } \phi = \text{phase angle.}$$

k is called the *wave number* and its unit in SI is m^{-1} . The above equation is for one dimensional harmonic waves traveling along the $+x$ axis. If the waves are moving along the $-x$ axis, the appropriate equation is:

$$y(x,t) = A \sin(kx + \omega t + \phi).$$

If $y = 0$ at $t = 0$ and $x = 0$, then $\phi = 0$. It is important to distinguish between the wave propagation velocity v (*along the x-axis*) and the medium's particles velocity v_y (*along the y-axis*) as transverse waves pass by the particles of the medium. The wave propagation velocity is $V = f\lambda$, but the particles velocity in the y-direction is $v_y = \partial y / \partial t$. The symbol " ∂ " denotes "*partial derivative*."

Example : The equation of certain traveling waves is

$$y(x,t) = 0.0450 \sin(25.12x - 37.68t - 0.523)$$

where x and y are in *meters*, and t in seconds. Determine the following: (a) Amplitude, (b) wave number, (c) wavelength, (d) angular frequency, (e) frequency, (f) phase angle, (g) the wave propagation speed, (h) the expression for the medium's particles velocity as the waves pass by them, and (i) the velocity of a particle that is at $x = 3.50\text{m}$ from the origin at $t = 21.0\text{s}$.

Solution: Comparing this equation with the general form, results in

(a) $A = 0.0450\text{m}$; (b) $k = 25.12\text{m}^{-1}$; (c) $\lambda = (2\pi/k) = 0.250\text{m}$

(d) $\omega = 37.68\text{rd/s}$; (e) $f = \omega/(2\pi) = 6.00\text{Hz}$; (f) $\phi = -0.523 \text{ rd}$;

(g) $v = f\lambda = 1.50\text{m/s}$; (h) $v_y = \partial y / \partial t = 0.045(-37.68) \cos(25.12x - 37.68t - 0.523)$

(i) $v_y(3.5\text{m}, 21\text{s}) = 0.045(-37.68) \cos(25.12*3.5 - 37.68*21 - 0.523) = -1.67\text{m/s}$.

Standing Harmonic Waves:

When two harmonic waves of equal frequency and amplitude travel through a medium in opposite directions, they combine and the result can form *standing waves*.

If the equation of the wave going to the right is $y_1 = A \sin(kx - \omega t)$ and that of the one going to the left is $y_2 = A \sin(kx + \omega t)$, we may add the two to obtain the equation of the *combination wave* as

$$y(x,t) = A \sin(kx - \omega t) + A \sin(kx + \omega t)$$

Using the trigonometric identity: $\sin a + \sin b = 2 \sin[(a + b)/2] \cos [(a - b)/2]$,

we get: $y(x,t) = 2A \cos(\omega t) \cdot \sin(kx)$.

In this equation, $\sin(kx)$ determines the shape of the standing wave and

$2A \cos(\omega t)$ determines how its amplitude varies with time.

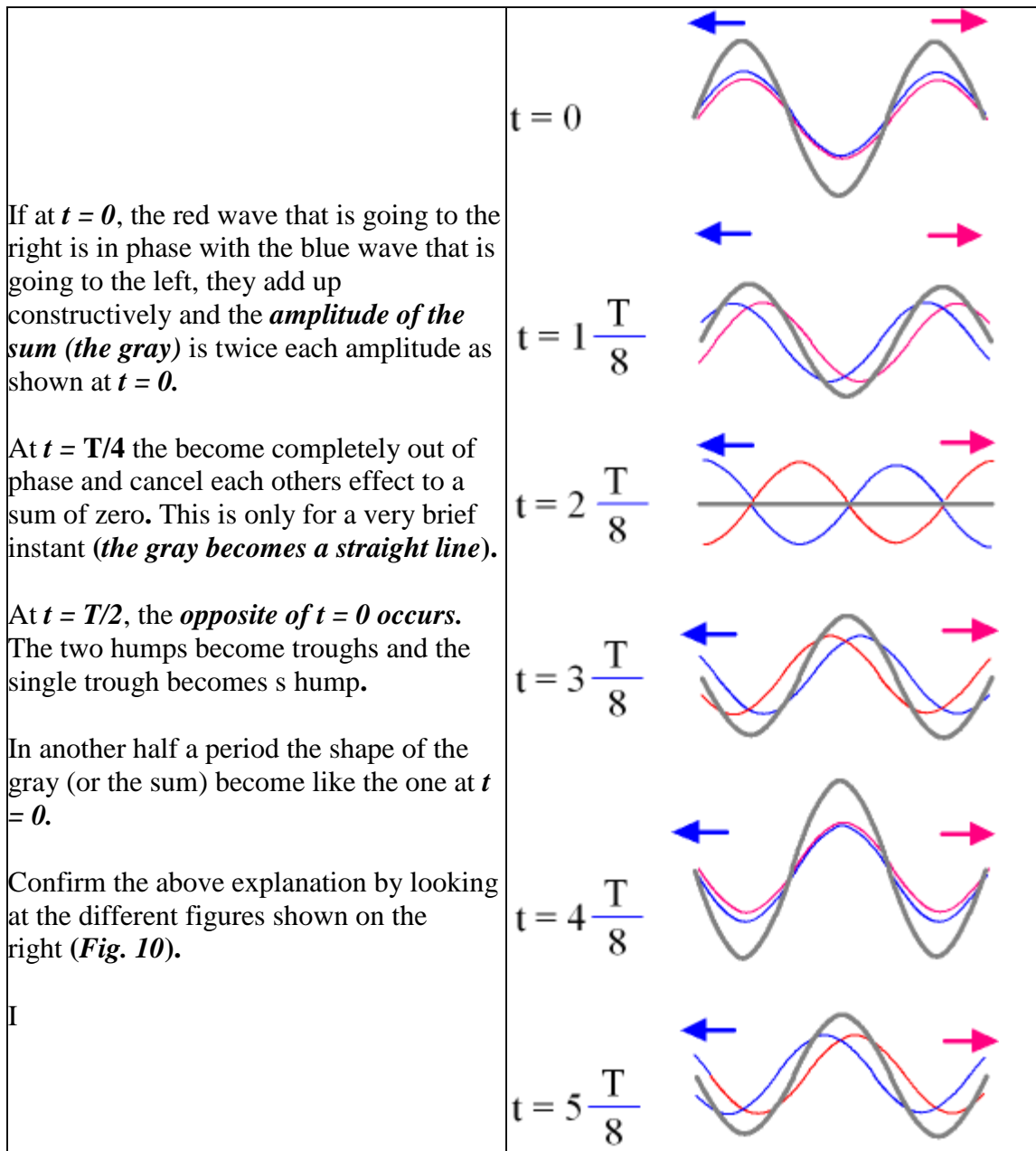

Figure 10

Resonant Standing Waves in A String:

In a medium with limited boundary such as a string fixed at both ends, standing waves can only be formed for a set of discrete frequencies or wavelengths.

If you hold one end of a rope, say 19ft long, and tie the other end of it to a wall 16ft away from you, there will be a slack of 3ft in it allowing you to swing it up and down and make waves. By adjusting the frequency of the oscillatory motion you give to the end you are holding, you can

generate a sequence of waves in the rope that will have an integer number of loops in it. For a frequency f , there is a corresponding wavelength λ such that $V = f\lambda$.

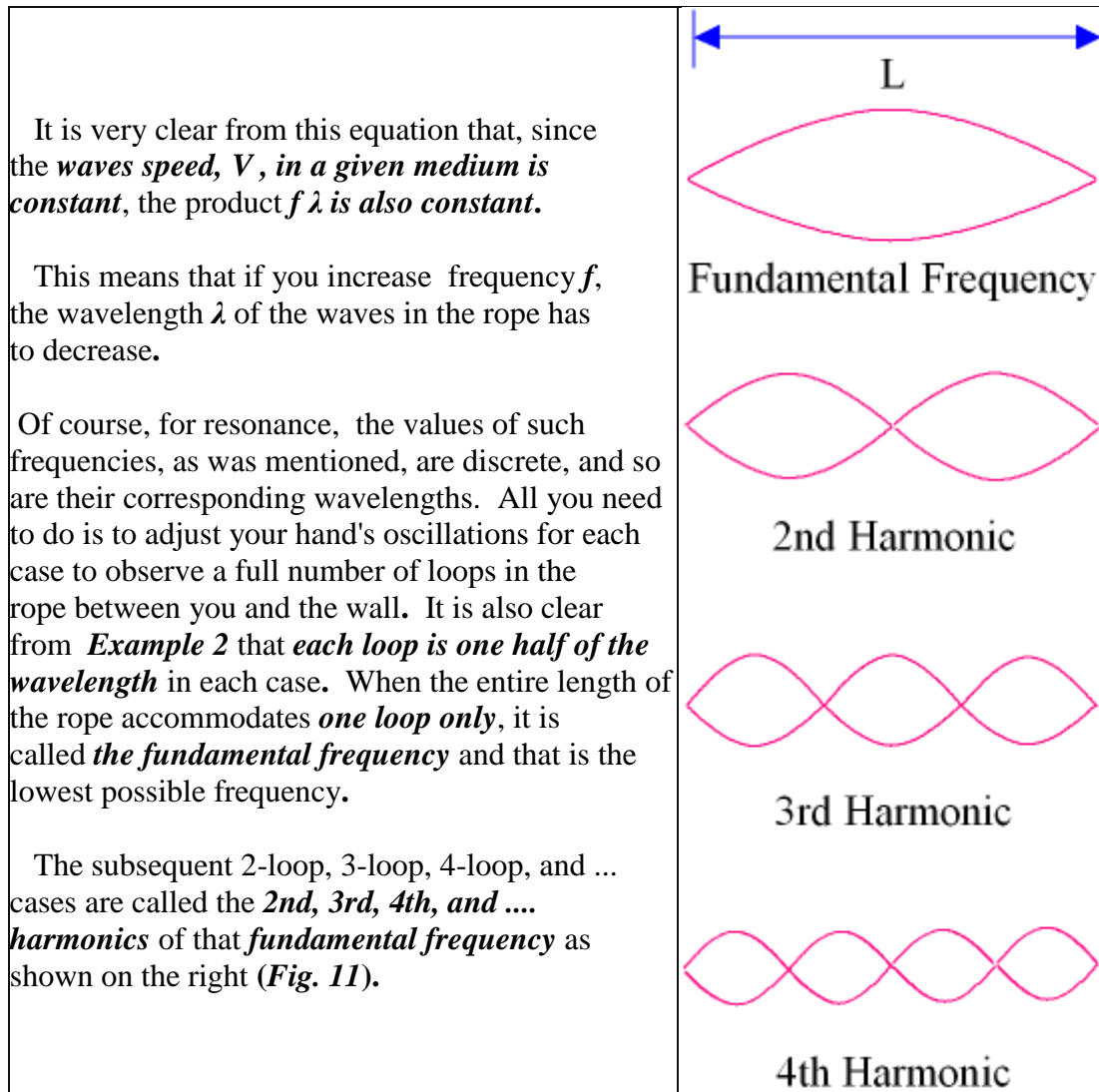

Figure 11

From the above figures, at resonance, the *length L* of the string is related to the number of loops or $\lambda/2$ as follows:

For 1 loop: $L = 1 \frac{\lambda_1}{2}$

For 2 loops: $L = 2 \frac{\lambda_2}{2}$

For 3 loops: $L = 3 \frac{\lambda_3}{2}$

For 4 loops: $L = 4 \frac{\lambda_4}{2}$

For n loops: $L = n \frac{\lambda_n}{2}$ or,

$$\lambda_n = \frac{2L}{n} \text{ or, } \boxed{f_n = \frac{nv}{2L}}$$

Since $v = \sqrt{\frac{F}{\mu}}$; thus,

$$\boxed{f_n = \frac{n}{2L} \sqrt{\frac{F}{\mu}}}$$

Example: Find the frequency of the 4th harmonic waves on a violin string that is 48.0cm long with a mass of 0.300grams and is under a tension of 4.00N.

Solution: Using the above formula,

$$f_4 = (4/0.96m) \cdot [4.00N/(0.000300kg/0.480m)]^{1/2} = 333\text{Hz (Verify).}$$

The Wave Equation:

The one-dimensional wave equation for mechanical waves applied to traveling waves has the following form:

$\frac{\partial^2 y}{\partial x^2} = \frac{1}{v^2} \frac{\partial^2 y}{\partial t^2}$	<p>where v is the speed of waves in the medium such that $v = \omega/k$.</p>
---	--

The solution to this equation is $y(x,t) = A \sin(kx - \omega t + \phi)$.

Example: Show that the equation $y(x,t) = A \sin(kx - \omega t + \phi)$ satisfies the wave equation.

Solution: Take the appropriate partial derivatives and verify by substitution.

Energy Transport on a String:

As a wave travels along a string, it transports energy by being flexed point by point, or dx by dx . By dx , we mean differential length. It is easy to calculate the *K.E.* and *P.E.* of a differential element as shown in *Fig. 12*. Let dl be a differential segment of the string. Corresponding to this dl , there is a dx and a dy as shown.

Note that dl is a stretched dx but has the *same mass* as dx .

If μ is mass per unit length, then the mass of the element is (μdx) .

The velocity of the element in the vertical direction is $\frac{\partial y}{\partial t}$.

The K.E. of the element is therefore,

$$d(\text{K.E.}) = \frac{1}{2} d(M) v^2 = \frac{1}{2} (\mu dx) \left(\frac{\partial y}{\partial t} \right)^2$$

To calculate the P.E., or the stored energy in the flexed string that acts as a linear spring ($F = kx$), we need to calculate the change in its length from dx to $d\ell$.

$$d\ell = \sqrt{(dx)^2 + (dy)^2} = (dx) \sqrt{1 + \left(\frac{\partial y}{\partial x} \right)^2}$$

$$d\ell = dx \left[1 + \frac{1}{2} \left(\frac{\partial y}{\partial x} \right)^2 + \dots \right] \quad (\text{Binomial Expansion})$$

The string is stretched from dx to $d\ell$ and therefore, the change in its length is

$$d\ell - dx = \frac{1}{2} \left(\frac{\partial y}{\partial x} \right)^2 dx.$$

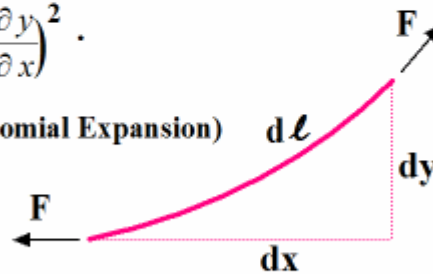

Figure 12

Multiplying this change in length by F , the tension in the string, give us the work done on it. This is equivalent to the differential potential energy, dU , stored in it.

$$dU = F (d\ell - dx) = \frac{1}{2} F \left(\frac{\partial y}{\partial x} \right)^2 dx.$$

Now, the total energy is dE , the sum of $d(\text{K.E.}) + dU$, or

$$dE = \frac{1}{2} (\mu dx) \left(\frac{\partial y}{\partial t} \right)^2 + \frac{1}{2} F \left(\frac{\partial y}{\partial x} \right)^2 dx.$$

Since $y(x,t) = A \sin(kx - \omega t)$, taking the appropriate derivatives and plugging into the above equation, yields:

$$dE = \frac{1}{2} \left[\mu (\omega A)^2 + F (kA)^2 \right] \cos^2(kx - \omega t) dx.$$

Since $\omega = vk$; therefore, $\omega^2 = v^2 k^2$ and since $v = \frac{F}{\mu}$, the two terms in the bracket become equal. Verify by substitution. We get:

$$dE = \mu (\omega A)^2 \cos^2(kx - \omega t) dx.$$

The average value of $\cos^2(\omega t)$ over **one period** is $1/2$; therefore, the average energy per oscillation is $dE = \frac{1}{2} \mu (\omega A)^2 dx$. Dividing sides by dt , we get:

the average power.

$$P = \frac{1}{2} \mu (\omega A)^2 v \quad \text{where } v = dx/dt \text{ and } P = dE/dt.$$

The conclusion is that the *power transmission* by a wave on a string is *proportional to the squares of angular speed and amplitude* and *linearly proportional to the wave speed V* in the string.

Example : A 1.00m-long string has a mass of 2.5 grams and is forced to oscillate at 400Hz while under a tensile force of 49N. If the maximum displacement of the string in the direction perpendicular to the waves propagation is 8.00mm, find its average power transmission.

Solution: We need to apply the formula $P_{avg} = 0.5\mu(\omega A)^2 v$.

First $\mu = M/L$, $\omega = 2\pi f$, A , and $V = (F/\mu)^{0.5}$ must be calculated.

$\mu = 2.5 \times 10^{-3}$ kg/m, $\omega = 2512$ rd/s, $V = 140$. m/s, $A = 4.00 \times 10^{-3}$ m , and finally, $P_{avg} = 17.7$ watts. Verify all calculations.