



INSTITUTE OF AERONAUTICAL ENGINEERING (Autonomous)

Dundigal, Hyderabad - 500 043

ELECTRICAL AND ELECTRONICS ENGINEERING

ASSIGNMENT

Course Name	:	NETWORK THEORY
Course Code	:	A40213
Class	:	II-B.TECH II SEM
Branch	:	Electrical and Electronics Engineering
Year	:	2016 - 2017
Course Coordinator	:	Ms. Lekha Chandran, Associate Professor
Course Faculty	:	Ms. Lekha Chandran, Associate Professor

OBJECTIVES:

This course introduces the basic concepts of network theory which is the foundation for all subjects of the electrical engineering discipline. The emphasis of this course is laid on the basic analysis of circuit which includes three phase circuits, transient analysis of DC and AC circuits, network functions, two port network parameters, Fourier analysis of ac circuits, Design and analysis of filters.

S. No	Question	Blooms Taxonomy Level	Course Outcome
UNIT - I Electrical circuits and Instruments SHORT ANSWER TYPE QUESTIONS			
1	What are the advantages of a three phase system over a single phase system	Understand	1
2	Obtain the relationship between line and phase voltage in a 3-phase balanced star connected system.	Remember	1
3	Obtain the relationship between line and phase voltage in a 3-phase balanced delta connected system.	Remember	1
4	Write the equations of line voltages in a balanced 3 phase system?	Remember	1
5	Obtain the relationship between line and phase current in a 3-phase balanced star connected system.	Understand	1
6	Obtain the relationship between line and phase currents in a 3-phase balanced delta connected system.	Remember	1
7	Remember the expression for power factor in an ac circuit?	Remember	1
8	Write the expression for active power in a balanced 3 phase circuit?	Remember	1
9	Write the expression for reactive power in a balanced 3 phase circuit?	Understand	1
10	Write the minimum number of wattmeters required for measuring 3 phase power?	Remember	1
11	Write the expression for total power in a balanced 3 phase circuit?	Remember	1

S. No	Question	Blooms Taxonomy Level	Course Outcome
12	Write down the expression for power factor in two wattmeter method?	Remember	1
13	Write down the relation between the readings of two wattmeters when the power factor is zero?	Understand	1
14	Write the value of neutral current in a balanced 3 phase system.	Remember	1
15	Define unbalanced loads.	Understand	1
LONG ANSWER QUESTIONS			
1	What is phase sequence? Explain its significance. What is the difference between RYB phase sequence and RBY phase sequence?	Apply	1
2	Derive the relationship between line and phase quantities in a 3-phase balanced, Star connected system.	Understand	1
3	Derive the relationship between line and phase quantities in a 3-phase Delta connected system balanced delta connected system.	Understand	1
4	Three identical impedances of $(3+j4)$ ohm are connected in delta. Find an equivalent star network such that the line current is the same when connected to the same supply.	Apply	1
5	Derive the expressions for wattmeter readings in two wattmeter method with balanced star connected load.	Understand	1
6	On a symmetrical 3-phase system, phase sequence RYB, a capacitive reactance of 8 is across YB and a coil $(R+jX)$ across RY. Find R and X such that $I_y = 0$	Apply	1
7	Derive the formula for power factor in two wattmeter method.		1
8	Three identical resistances are connected in a star fashion against a balanced three phase voltage supply. If one of the resistance is removed, how much power is to be reduced?	Apply	1
9	Explain the effect of power factor on wattmeter readings in two wattmeter method?	Understand	1
10	Explain how reactive power can be measured in three phase circuits?		1
11	Three identical impedances of $(3+j4)$ ohm are connected in star. Find an equivalent delta network such that the line current is the same when connected to the same supply.	Apply	1
12	Derive the relationship between line and phase voltage in a 3-phase balanced delta connected system	Understand	1
13	Explain a balanced 3 phase system star connected and delta connected system?	Understand	1
14	Derive the relationship between line and phase current in a 3-phase balanced star connected system.	Understand	1
15	Derive the relationship between line and phase voltage in a 3-phase balanced delta connected system.	Understand	1
UNIT – II DC and AC transient analysis SHORT ANSWER TYPE QUESTIONS			
1	Explain why the current in a pure inductance cannot change in zero time	Remember	2
2	Explain why the voltage across a capacitor cannot change instantaneously	Remember	2
3	What is the significance of time constant of R-L circuit?	Remember	2

S. No	Question	Blooms Taxonomy Level	Course Outcome
4	What are the different ways of defining time constant	Remember	2
5	What are initial conditions	Remember	2
6	Distinguish between steady state and transient response	Understand	2
7	What is mean by steady state condition?	Remember	2
8	Explain initial conditions in a network?	Remember	2
9	Explain initial conditions of basic passive elements?	Remember	2
10	What is the significance of initial conditions in a step response of r-l and r-	Remember	2
11	What is meant by step response of circuit?	Remember	2
12	What is mean by steady state condition?	Remember	2
LONG ANSWER QUESTIONS			
1	Distinguish between steady state and transient response of electric circuits.	Apply	2
2	Derive the expression for $i(t)$ of a R-L series circuit when DC voltage is applied to it at $t=0$ by closing the switch. Draw the response curve $i(t)$ vs t . define time constant of R-L series circuit	Apply	2
3	Derive the expression for $i(t)$ and voltage across a capacitor $V_c(t)$ for series R-C circuit with D.C voltage applied to it at $t=0$. Explain about the time constant of R-C circuit	Understand	2
4	Derive the transient response for series RLC circuit for DC excitation.	Understand	2
5	Derive the transient response for series RL circuit for sinusoidal excitation.	Understand	2
6	Derive the transient response for series RC circuit for sinusoidal excitation.	Understand	2
7	Derive the transient response for series RLC circuit for sinusoidal excitation.	Understand	2
8	Compare the classical and Laplace transform methods of solution of the network	Understand	2
9	A series RL circuit with $R = 50$ ohms and $L = 0.2$ H has a sinusoidal voltage source $V = 150 \sin 500t$ volts applied at a time when $\phi=0$. Find the expression for the total current. Use Laplace transforms method	Apply	2
10	A series R C circuit with $R = 100 \Omega$ and $C = 25 \mu\text{F}$ has a sinusoidal excitation $V(t) = 250 \sin 500t$. Find the total current assuming that the capacitor is initially uncharged	Apply	2
11	For the circuit shown in Figure determine the particular solution for $i(t)$ through the circuit. Assume zero initial conditions	Apply	2

S. No	Question	Blooms Taxonomy Level	Course Outcome
	<p style="text-align: center;">$V(t) = 6 \sin(10^4 t + \pi/4) \text{ V}$</p>		
12	A series RL circuit with $R = 50$ ohms and $L = 0.2$ H has a sinusoidal voltage source $V = 150 \sin(\omega t + \phi)$ volts applied at a time when $\phi=0$. Find the expression for the total current. Use Laplace transforms method	Apply	2
13	A series RC circuit with $R = 50$ ohms and $C = 2$ micro farad has a sinusoidal voltage source $V = 150 \sin(\omega t + \pi/3)$ volts applied at a time when $\phi=0$. Find the expression for the total current. Use Laplace transforms method	Apply	2
14	A dc voltage of 20V is applied in a RL circuit where $R = 5$ and $L = 10$ H. Find i. The time constant ii. The maximum value of stored energy	Apply	2
15	A Sinusoidal Voltage of $12 \sin 8 t$ Volts is applied at $t = 0$ to a RC series of $R= 4\Omega$ and $L = 1$ H. By Laplace transform method determine the circuit current $i(t)$ for. Assume zero initial condition	Apply	2
UNIT – III Network Functions SHORT ANSWER TYPE QUESTIONS			
1	Explain the concept of complex frequency	Understand	3
2	Define Neper frequency	Understand	3
3	Define Radian frequency	Remember	3
4	Define damped sinusoid	Remember	3
5	Obtain the transform representation of a series RLC circuit	Understand	3
6	Obtain the transform representation of a parallel RLC circuit	Remember	3
7	Obtain the transform impedance of an inductor	Understand	3
8	Obtain the transform impedance of a capacitor	Remember	3
9	What is a driving point function? Explain with one example	Understand	3
10	Explain any two necessary conditions for driving point functions	Understand	3
11	What is a transfer function? Give one example	Remember	3
12	Explain any two necessary conditions for transfer functions	Understand	3
13	According to Routh Criteria when a network is said to be stable?	Remember	3
14	Find the stability of the network with transfer function $Q(s) = 10s/(s+2)(s+5)$ using pole zero plot	Understand	3

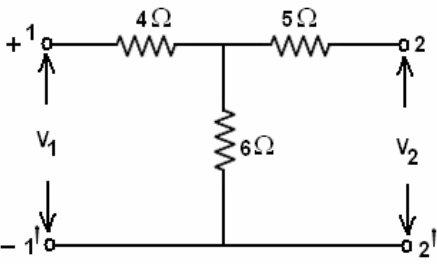
S. No	Question	Blooms Taxonomy Level	Course Outcome
15	Find the stability of the network with transfer function $Q(S) = 40S/S^3 + 2S^2 + 8S + 1$ using pole zero plot	Remember	3
16	The transform voltage $V(s)$ of a network is given by $V(s) = 4s/(s+2)(s^2+2s+2)$. Plot its pole-zero diagram	Remember	3
17	For the given network function draw pole zero diagram $I(s) = 5S / (S+1)(s^2+4S+8)$	Evaluate	3
18	The Laplace transform of a voltage $v(t)$ is $V(s) = 4(s+1)/(s+2)(s+3)$. Draw poles and zeros of this function.	Evaluate	3
LONG ANSWER QUESTIONS			
1	What is a pole-zero plot? What is its significance? Explain time domain behavior from pole zero plot.	Create	3
2	Define and explain the following : port, driving point functions And Transfer functions	Evaluate	3
3	What is a transfer function? Explain the necessary conditions for transfer functions	Evaluate	3
4	What is a driving point function? Explain the necessary conditions for driving point functions	Analyze	3
5	According to Routh Criteria when a network is said to be stable?	Evaluate	3
6	The Laplace transform of a voltage $v(t)$ is $V(s) = 4(s+1)/(s+2)(s+3)$. Draw poles and zeros of this function and determine $v(t)$ using pole-zero plot	Evaluate	3
7	The transform voltage $V(s)$ of a network is given by $V(s) = 4s/(s+2)(s^2+2s+2)$ plot its pole-zero diagram and hence obtain $v(t)$	Evaluate	3
8	Find the stability of the network $Q(S) = 40S/S^3 + 2S^2 + 8S + 1$	Remember	3
9	Find Y parameters for the above network shown in Figure 	Understand	3
10	For the given network function draw pole zero diagram and hence obtain the time domain response $i(t)$ if $I(s) = 5S / (S+1)(s^2+4S+8)$	Understand	3
11	Explain the transfer functions of two port networks	Evaluate	3
12	Obtain the value of $i(t)$. Assume no initial charge in the capacitor at time $t=0$.	Remember	3

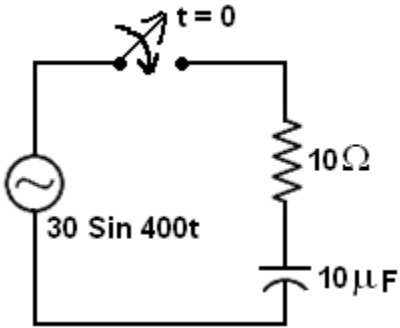
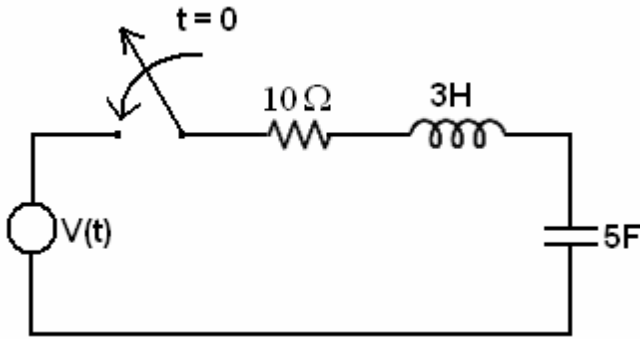
S. No	Question	Blooms Taxonomy Level	Course Outcome
			
13	<p>Draw the transformed network for the given circuit</p> 	Understand	3
14	The Laplace transform of a voltage $v(t)$ is $V(s)=4(s+1)/(s+2)(s+3)$. Draw poles and zeros of this function and determine $v(t)$ using pole-zero plot	Understand	3
15	Find the stability of the network $Q(S) = 40S/S^3 + 2S^2 + 8S + 1$	Understand	3
UNIT-IV NETWORK PARAMETERS SHORT ANSWER TYPE QUESTIONS			
1	Define active and passive ports	Create	3
2	Why Z-parameters are called as open circuit impedance (Z) parameter	Evaluate	3
3	Define open circuit forward transfer impedance	Evaluate	3
4	Give the condition for reciprocity for Z parameters	Analyze	3
5	Why Y parameters are called as short circuit admittance parameters	Evaluate	3
6	What are the applications of cascaded ABCD parameters	Evaluate	3
7	Express y-parameters in terms of h-parameters	Evaluate	3
8	Express Z-parameters in terms of h-parameters	Remember	3
9	Express Z parameters in terms of ABCD parameters	Create	3
10	Express h-parameters in terms of ABCD parameters	Create	3
11	How many terminals a two port does a network have	Evaluate	3
12	Write the condition for a two port network to be reciprocal.	Evaluate	3

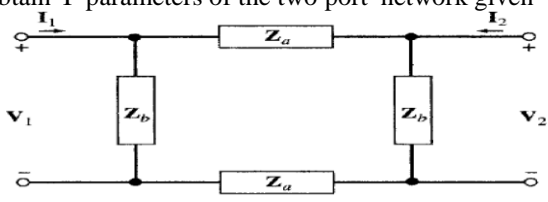
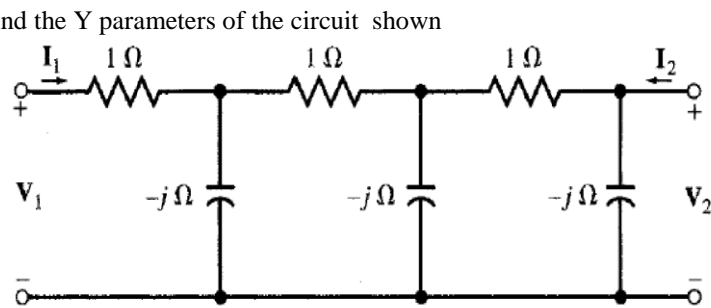
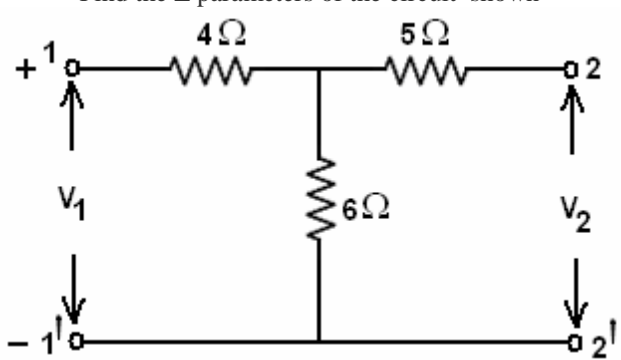
S. No	Question	Blooms Taxonomy Level	Course Outcome
13	Which parameters are widely used in transmission line theory	Analyze	3
14	How can we obtain the h parameters of a circuit	Evaluate	3
15	Write the equation for the transfer impedance of a two port network	Evaluate	3
LONG ANSWER QUESTIONS			
1	Obtain Y-parameters of the two port network given 	Evaluate	3
2	Find the Y parameters of the circuit shown 	Evaluate	3
3	The Z parameters of a two port network are $Z_{11}=6\Omega$, $Z_{22}=4\Omega$, $Z_{12}=Z_{21}= 3\Omega$ Compute Y and ABCD Parameters and write the describing equations	Evaluate	3
4	Discuss in detail about series and parallel connection of two port networks	Evaluate	3
5	Find the Z parameters of the circuit shown 	Evaluate	3
6	Find the h parameters of the circuit shown	Evaluate	3

S. No	Question	Blooms Taxonomy Level	Course Outcome
7	Determine the image parameters of a T network with branch impedances 1 ohm, 2 ohm and 5 ohm.	Evaluate	3
8	Explain image parameters with necessary expressions	Evaluate	3
9	The Z parameters of a two port network are $Z_{11} = 10$ ohm, $Z_{22} = 15$ ohm, $Z_{12} = Z_{21} = 5$ ohm. Find the equivalent T network.	Evaluate	3
10	The Z parameters of a two port network are $Z_{11} = 10$ ohm, $Z_{22} = 15$ ohm, $Z_{12} = Z_{21} = 5$ ohm. Find the ABCD parameters.	Evaluate	3
11	Obtain the expressions for Y parameters of when two two port networks are connected in parallel	Evaluate	3
12	Find the ABCD parameters of the circuit shown 	Evaluate	3
UNIT-V Filters and Fourier analysis of AC circuits SHORT ANSWER TYPE QUESTIONS			
1	What is low pass filter derive expression for cutoff frequency of proto type low pass filter in terms of l and c?	Understand	4
2	Obtain design equations of high pass filter?	Understand	4
3	Draw a circuit of a band stop filter and explain its working with neat reactance curves?	Understand	4
4	For band stop filter show that resonant frequency is the geometric mean of two cut-off frequencies?	Remember	4
5	What are disadvantages of proto type filters?	Remember	4
6	Explain in brief m-derived filter section overcome limitations of proto type filter section?	Remember	4
7	Write notes on termination with m-derived half section?	Understand	4
8	Categorize filters and explain	Remember	4
9	Describe a proto type t section band stop filter. Determine the formula for designing band pass filter?	Understand	4

S. No	Question	Blooms Taxonomy Level	Course Outcome
10	Draw the wave form and obtain the Fourier series of a single rectangular pulse when the pulse has period of 2 seconds and start from origin.	Remember	4
LONG ANSWER QUESTIONS			
1	Define a filter and What are the classification of filters	Understand	4
2	Explain the formula for characteristic impedance of symmetrical T-Section	Create	4
3	Explain the design procedure for a constant K low pass filter and its characteristics	Understand	4
4	Write short note on m-derived filters	Create	4
5	Design a proto type section of band pass filter having cut-off frequencies of 12KHz and,16 KHz and a design impedance of 600 ohm	Understand	4
6	Write short notes on Fourier transform theorems.	Create	5
7	Write short notes on Exponential form of Fourier series	Understand	5
8	Write short notes on Line and phase angle spectra	Apply	5
9	Write short notes on Fourier integrals	Understand	5
10	Design a proto type section of band pass filter having cut-off frequencies of 1 KHz and, 5 KHz and a design impedance of 600ohm	Evaluate	4
11	A constant K low pass filter is designed to cut-off at a frequency of 1000Hz and the resistance of the load circuit is 50ohm .Calculate the values of the corresponding components required	Synthesize	4

Prepared by: Ms. Lekha Chandran, Associate Professor

HOD, EEE