



INSTITUTE OF AERONAUTICAL ENGINEERING
(Autonomous)
Dundigal, Hyderabad -500 043

AERONAUTICAL ENGINEERING

COURSE LECTURE NOTES

Course Name	FOUNDATION ENGINEERING
Course Code	ACE018
Programme	B.Tech
Semester	VIII
Course Coordinator	Ms.U. Deepthi, Assistant professor
Course Faculty	Mr. N. Venkat Rao, Associate Professor Ms.U. Deepthi, Assistant professor Ms. V.Aivelu manga, Assistant professor
Lecture Numbers	1-46
Topic Covered	All

COURSE OBJECTIVES (COs):

The course should enable the students to:	
I	Understand various methods of soil exploration and field tests on soil, planning and preparation of soil investigation programme.
II	Analyze the stability of infinite and finite slopes
III	Calculate At rest, Active and Passive earth pressures of soil & Analyze the stability of retaining wall against sliding, overturning and bearing capacity failures.
IV	Calculate the bearing capacity of shallow and deep foundation from theoretical & field tests.

COURSE LEARNING OUTCOMES (CLOs):

Students, who complete the course, will have demonstrated the ability to do the following:

ACE018.01	Understand the need and methods of Soil Exploration
ACE018.02	Understand various methods of sampling and boring
ACE018.03	Learn how to perform field tests such as SPT, DCPT, CPT
ACE018.04	Learn how to perform Plate Load test for finding load bearing capacity, settlements of soils
ACE018.05	Learn how to perform in-situ test using pressure meter
ACE018.06	Understand the importance of geophysical methods

ACE018.07	Learn how to prepare Soil investigation Report
ACE018.08	Understand basic concepts of earth slopes
ACE018.09	Analyze failure of infinite slopes
ACE018.10	Analyze types of failures for finite slopes
ACE018.11	Learn how to find Stability of slopes by Swedish arc Method
ACE018.12	Learn how to find Stability of slopes by Method of Slices for slopes
ACE018.13	Find Stability of slopes by Taylor's Stability number
ACE018.14	Understand basic concepts of Stability of slopes of earth dam under different conditions
ACE018.15	Understand concepts of earth pressure theories for stability of Retaining walls
ACE018.16	Calculate active and passive earth pressures from Rankine's earth pressure theories
ACE018.17	Calculate active and passive earth pressures from Coulomb's & Culmann's Method
ACE018.18	Asses the stability of retaining wall against overturning, sliding, bearing capacity
ACE018.19	Understand the concepts of safe bearing capacity, ultimate bearing capacity etc.,
ACE018.20	Calculate the bearing capacity of shallow foundation using Terzaghi, Meyerhof, Skempton and IS Methods.
ACE018.21	Calculate the load carrying capacity of pile using static, dynamic pile formula and pile load test
ACE018.22	Calculate load carrying capacity of pile group in sands and clay & settlement of pile group
ACE018.23	Learn different shapes of well & components of Well Foundation
ACE018.24	Understand the principle of analysis and design of wells, Seismic analysis and IRC guidelines

SYLLABUS

UNIT-I	SOIL EXPLORATION	Classes: 09
Need and methods of soil exploration, boring and sampling methods, pits and trenches, drifts and shafts, methods of boring, auger borings, wash borings, rotary drilling, percussion drilling, core drilling, types of soil samples, disturbed samples, undisturbed samples, design features affecting the sample disturbance, split spoon samplers, scraper bucket samplers, shell by tubes and thin walled samplers, piston samplers, preservation and handling of samples. penetration tests, monotonic and cyclic, field permeability tests, in-situ tests using pressure meter, observation of ground water table, instrumentation in soil engineering, strain gauges, resistance and inductance type plate load test, pressure meter, geophysical methods, planning of programme and preparation of soil investigation report.		
UNIT-II	SLOPE STABILITY	Classes: 09
Infinite and finite earth slopes, types of failures, factor of safety of infinites lopes, stability analysis by Swedish arc method, standard method of slices, Bishop's Simplified method, Taylor's Stability number, and stability f slopes of earth dams under different conditions.		

UNIT-III	EARTH PRESSURE THEORIES AND RETAINING WALLS	Classes: 09
<p>Rankine's theory of earth pressure, earth pressures in layered soils, Coulomb's earth pressure theory, and Culmann's graphical method.</p> <p>Types of retaining walls, stability of retaining walls against overturning, sliding, bearing capacity and drainage from backfill.</p>		
UNIT-IV	SHALLOW AND DEEP FOUNDATIONS	Classes: 09
<p>Types, choice of foundation, location of depth, safe bearing capacity, Terzaghi, Meyerhof, Skempton and IS Methods. Safe bearing pressure based on N value, allowable bearing pressure, safe bearing capacity, plate load test, allowable settlements of structures, Analysis of foundation, individual, strip, combined footings and mat foundations conventional, elastic approach, soil structure interaction principles. Types of piles, load carrying capacity of piles based on static pile formulae in dynamic pile formulae, pile load tests, load carrying capacity of pile groups in sands and clays, settlement of pile groups. Introduction to foundations on expansive soils and marine foundations.</p>		
UNIT-V	WELL FOUNDATIONS	Classes: 09
<p>Different shapes of wells, components of well, sinking of well, tilts and shifts, principles of analysis and design, seismic influences, IRC guidelines</p>		
Text Books:		
<ol style="list-style-type: none"> 1. Braja M. Das, "Principles of geotechnical engineering" Cengage learning publishers, 2002 2. V.N.S Murthy, "Geotechnical Engineering: Principles and practices of soils mechanics and foundation engineering", Taylor & Francis Group, 2002. 3. Gopal Ranjan and ASR Rao, "Basic and Applied Soil Mechanics", New age international Pvt. Ltd, New Delhi, 2000. 		
Reference Books:		
<ol style="list-style-type: none"> 1. C. Venkataramiah, "Geotechnical engineering", New Age International Pvt. Ltd, 2002. 2. Manoj Dutta and Gulati, "Geotechnical engineering", Tata Mc Grawhill publishers New Delhi, 2005. 3. K.R .Arora, "Soil mechanics and foundation engineering", standard publishers and distributors, New Delhi, 2005. 		
Web References:		
<ol style="list-style-type: none"> 1. http://nptel.ac.in/courses/105107120/1# 2. https://ocw.mit.edu/courses/civil,and,environmental,engineering/1,364,advanced,geotechnical,engineering,fall,2003/index.html 		

UNIT I

SOIL EXPLORATION

Introduction: Soil exploration is a part of site investigation. Site investigation, in general deals with determining in general, the suitability of the site for the proposed construction.

Methods of Investigation:

Test pits

Permits visual inspection of subsurface conditions in natural state. Max. depth limited to 5-6 m. Especially useful for gravelly soil where boreholes may be difficult. Sampling/testing done on exposed surfaces.

Auger Borings

Simplest method of exploration and sampling. Power driven or hand operated. Max. depth 10 m. Suitable in all soils above GWT but only in cohesive soil below GWT . Hollow stem augers used for sampling or conducting Standard Penetration Tests.

Displacement borings

It is combined method of sampling & boring operation. Closed bottom sampler, slit cup, or piston type is forced in to the ground up to the desired depth. Then the sampler is detached from soil below it, by rotating the piston, & finally the piston is released or withdrawn. The sampler is then again forced further down & sample is taken. After withdrawal of sampler & removal of sample from sampler, the sampler is kept in closed condition & again used for another depth.

Features :

- Simple and economic method if excessive caving does not occur. Therefore not suitable for loose sand.
- Major changes of soil character can be detected by means of penetration resistance. These are 25mm to 75mm holes.
- It requires fairly continuous sampling in stiff and dense soil, either to protect the sampler from damage or to avoid objectionably heavy construction pit.

Wash boring:

It is a popular method due to the use of limited equipments. The advantage of this is the use of inexpensive and easily portable handling and drilling equipments. Here first an open hole is formed on the ground so that the soil sampling or rock drilling operation can be done below the hole. The hole is advanced by chopping and twisting action of the light bit. Cutting is done by forced water and water jet under pressure through the rods operated inside the hole.

In India the —Dheki operation is used, i.e., a pipe of 5cm diameter is held vertically and filled with water using horizontal lever arrangement and by the process of suction and application of pressure, soil slurry comes out of the tube and pipe goes down. This can be done upto a depth of 8m –10m (excluding the depth of hole already formed beforehand)

Just by noting the change of colour of soil coming out with the change of soil character can be identified by any experienced person. It gives completely disturbed sample and is not suitable for very soft soil, fine to medium grained cohesionless soil and in cemented soil.

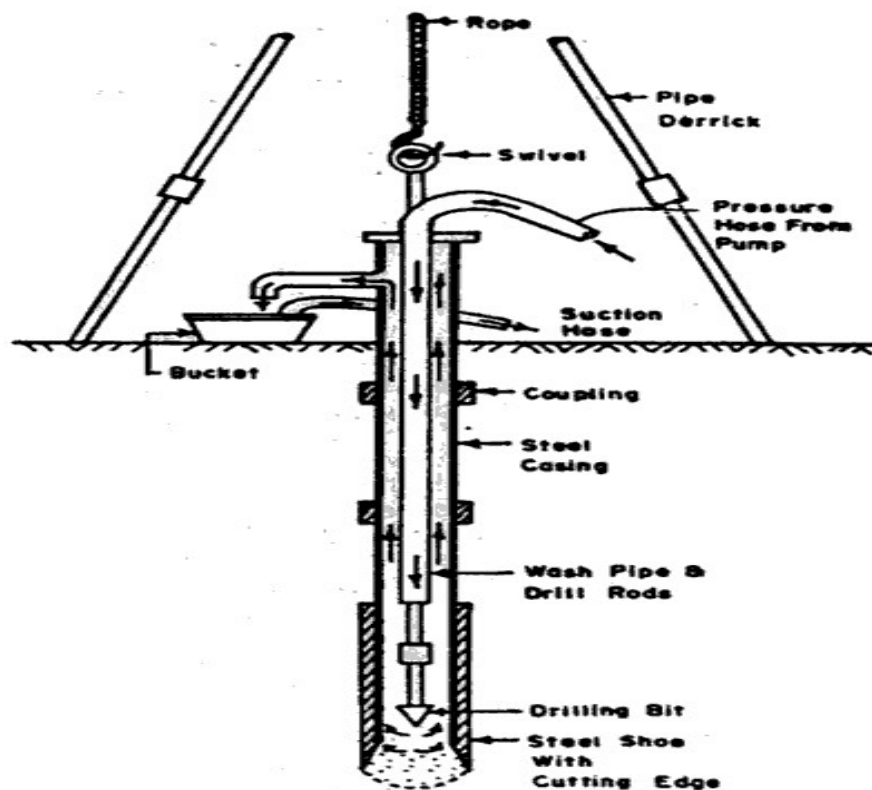

1.1 Planning For Subsurface Exploration

The planning of the site exploration program involves location and depth of borings, test pits or other methods to be used, and methods of sampling and tests to be carried out. The purpose of the exploration program is to determine, within practical limits, the stratification and engineering properties of the soils underlying the site. The principal properties of interest will be the strength, deformation, and hydraulic characteristics. The program should be planned so that the maximum amount of information can be obtained at minimum cost. In the earlier stages of an investigation, the information available is often inadequate to allow a firm and detailed plan to be made. The investigation is therefore performed in the following phases:

- a. Fact finding and geological survey
- b. Reconnaissance
- c. Preliminary exploration
- d. Detailed exploration

1. Fact finding and geological survey

Assemble all information on dimensions, column spacing, type and use of structure, basement requirements, and any special architectural considerations of the proposed building. Foundation regulations in the local building code should be consulted for any special requirements. For bridges the soil engineer should have access to type and span lengths as well as pier loadings. This information will indicate any settlement limitations, and can be used to estimate foundation loads.

2. Reconnaissance

This may be in the form of a field trip to the site which can reveal information on the type and behavior of adjacent sites and structures such as cracks, noticeable sags, and possibly sticking doors and windows. The type of local existing structure may influence, to a considerable extent, the exploration program and the best foundation type for the proposed adjacent structure. Since nearby existing structures must be maintained, excavations or vibrations will have to be carefully controlled. Erosion in existing cuts (or ditches) may also be observed. For highways, run off patterns, as well as soil stratification to the depth of the erosion cut, may be observed. Rock outcrops may give an indication of the presence or the depth of bedrock.

3. Auger boring

This method is fast and economical, using simple, light, flexible and inexpensive instruments for large to small holes. It is very suitable for soft to stiff cohesive soils and also can be used to determine ground water table. Soil removed by this is disturbed but it is better than wash boring, percussion or rotary drilling. It is not suitable for very hard or cemented soils, very soft

soils, as then the **flow** into the hole can occur and also for fully saturated cohesionless soil.

Shell and Auger Boring

Shell used for soil with sides of the hole cannot remain unsupported. Boring is always started first with augering and the shell is used for advancing the bore hole. Shell raised above the bottom of the hole and allows it to fall freely. The impact of the drop cuts the soil and pushes the soil in to the tube. After filled, shell is withdrawn and emptied.

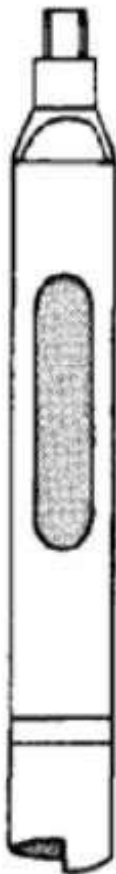

Percussion Drilling

Heavy drill bit suspended from a drill rod or a cable and is driven by repeated blows. Water is added to facilitate the breaking of stiff soil or rock. Not suitable for loose sand and is slow in plastic clays.

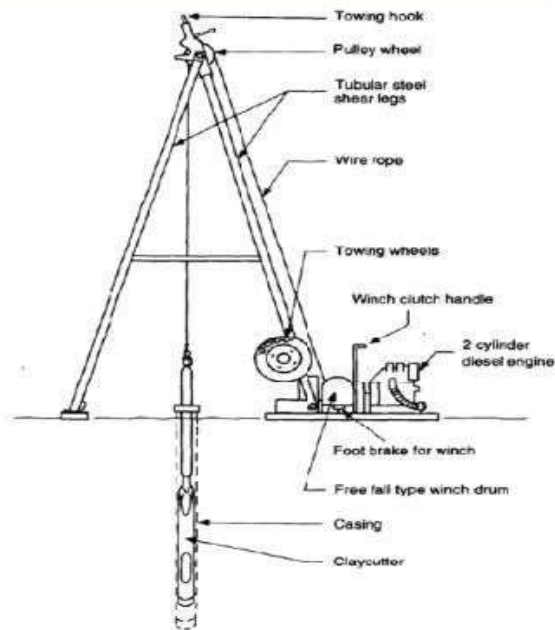

Rotary Drilling:

Fast in rocks. Drill bit fixed to the lower end of a drill rod is rotated by power. Bentonite slurry is forced under pressure through the drill rod and it comes up along the cutting soil. Rock cores can be obtained by using suitable diamond drill bits and core barrels

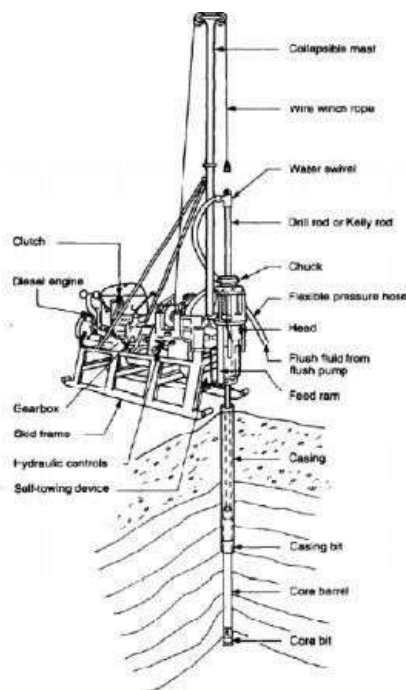

Soil Sampling:

Disturbed samples: The structure of the soil is disturbed to the considerable degree by the action of the boring tools or the excavation equipments. The disturbances can be classified in following basic types:

- Change in the stress condition
- Change in the water content and the void ratio
- Disturbance of the soil structure

The causes of the disturbances are listed below:

- Method of advancing the borehole Mechanism used to advance the sampler
- Dimension and type of sampler Procedure followed in sampling and boring.

Undisturbed samples: It retains as closely as practicable the true insitu structure and water content of the soil. For undisturbed sample the stress changes can not be avoided. The following requirements are looked for:

- No change due to disturbance of the soil structure
- No change in void ratio and water content,
- No change in constituents and chemical properties.

$$(C_i) = \frac{D_s - D_c}{D_c} \times 100\%$$

4 Requirement of good sampling process : Inside clearance ratio The soil is under great stress as it enters the sampler and has a tendency to laterally expand. The inside clearance should be large enough to allow a part of lateral expansion to take place, but it should not be so large that it permits excessive deformations and causes disturbances of the sample. For good sampling process, the inside clearance ratio should be within 0.5 to 3 %. For sands silts and clays, the ratio should be 0.5 % and for stiff and hard clays (below water table), it should be 1.5 %.

$$(A_r) = \frac{D_w^2 - D_c^2}{D_c^2} \times 100\%$$

For stiff expansive type of clays, it should be 3.0 %.

Recovery ratio

$$(R) = \frac{L}{H} \times 100\%$$

Where, L is the length of the sample within the tube,

H is the depth of penetration of the sampling tube.

It represents the disturbance of the soil sample. For good sampling the recovery ratio should be 96 to 98 %.

Wall friction can be reduced by suitable inside clearance, smooth finish and oiling. The non-returned wall should have large orifice to allow air and water to escape.

Depth of Exploration

Governed by the depth of the influence zone which depends on the type of structure, intensity of loading, shape and disposition of the loaded area, the soil profile and the physical characteristics of the soil. The depth upto which the stress increment due to superimposed loads can produce significant settlement and shear stress is known as the "Significant Depth".

Empirical Relationship for Multi-storied Buildings

$$D = C (S)^{0.7}$$

where

D = Depth of exploration

C = Constant = 3 for Light steel buildings & Narrow concrete bldgs

= 6 for Heavy Steel bldgs & Wide Concrete Concrete bldgs.

S = No. of storey's

Spacing of Borings

The number and spacing of bore holes or trial pits will depend upon the extent of the site and nature of structures coming on it. For a compact building site covering an area of about 0.4 hectre, one bore hole or trial pit in each corner and one in the centre. For smaller buildings, one bore hole or trial pit in the centre.

Sl. No.	Nature of project	Spacing
1.	Highways	300 to 600 m
2.	Earth dams	30 to 60 m
3.	Borrow pits	30 to 120 m
4.	Multi-storey buildings	15 to 30 m
5.	Single storey factories	30 to 90 m.

In-situ tests

General:

The in situ tests in the field have the advantage of testing the soils in their natural, undisturbed condition. Laboratory tests, on the other hand, make use of small size samples obtained from boreholes through samplers and therefore the reliability of these depends on the quality of the so called 'undisturbed' samples.

Further, obtaining undisturbed samples from non-cohesive, granular soils is not easy, if not impossible. Therefore, it is common practice to rely more on laboratory tests where cohesive soils are concerned. Further, in such soils, the field tests being short duration tests, fail to yield meaningful consolidation settlement data in any case. Where the subsoil strata are essentially non-cohesive in character, the bias is most definitely towards field tests. The data from field tests is used in empirical, but time-tested correlations to predict settlement of foundations. The field tests commonly used in subsurface investigation are:

- Penetrometer test
- Pressure meter test
- Vane shear test Plate load test
- Geophysical methods

Penetrometer Tests :

- Standard penetration test (SPT)
- Static cone penetration test (CPT)
- Dynamic cone penetration test (DCPT)

Standard penetration test:

The standard penetration test is carried out in a borehole, while the DCPT and SCPT are carried out without a borehole. All the three tests measure the resistance of the soil strata to penetration by a penetrometer. Useful empirical correlations between penetration resistance and soil properties are available for use in foundation design.

This is the most extensively used penetrometer test and employs a split-spoon sampler, which consists of a driving shoe, a split-barrel of circular cross-section which is longitudinally split into two parts and a coupling. IS: 2131-1981 gives the standard for carrying out the test.

Procedure :

1. The borehole is advanced to the required depth and the bottom cleaned.
2. The split-spoon sampler, attached to standard drill rods of required length is lowered into the borehole and rested at the bottom.

3. The split-spoon sampler is driven into the soil for a distance of 450mm by blows of a drop hammer (monkey) of 65 kg falling vertically and freely from a height of 750 mm. The number of blows required to penetrate every 150 mm is recorded while driving the sampler. The number of blows required for the last 300 mm of penetration is added together and recorded as the N value at that particular depth of the borehole. The number of blows required to effect the first 150mm of penetration, called the seating drive, is disregarded. The split-spoon sampler is then withdrawn and is detached from the drill rods. The split-barrel is disconnected from the cutting shoe and the coupling. The soil sample collected inside the split barrel is carefully collected so as to preserve the natural moisture content and transported to the laboratory for tests. Sometimes, a thin liner is inserted within the split-barrel so that at the end of the SPT, the liner containing the soil sample is sealed with molten wax at both its ends before it is taken away to the laboratory. The SPT is carried out at every 0.75 m vertical intervals in a borehole. This can be increased to 1.50 m if the depth of borehole is large. Due to the presence of boulders or rocks, it may not be possible to drive the sampler to a distance of 450 mm. In such a case, the N value can be recorded for the first 300 mm penetration.

- The boring log shows refusal and the test is halted if
- 50 blows are required for any 150mm penetration
- 100 blows are required for 300m penetration
- 10 successive blows produce no advance.

Precautions

- The drill rods should be of standard specification and should not be in bent condition.
- The split spoon sampler must be in good condition and the cutting shoe must be free from wear and tear.
- The drop hammer must be of the right weight and the fall should be free, frictionless and vertical. The height of fall must be exactly 750 mm. Any change from this will seriously affect the N value.
- The bottom of the borehole must be properly cleaned before the test is carried out. If this is not done, the test gets carried out in the loose, disturbed soil and not in the undisturbed soil. When a casing is used in borehole, it should be ensured that the casing is driven just short of the level at which the SPT is to be carried out. Otherwise, the test gets carried out in a soil plug enclosed at the bottom of the casing.

- When the test is carried out in a sandy soil below the water table, it must be ensured that the water level in the borehole is always maintained slightly above the ground water level.
- If the water level in the borehole is lower than the ground water level, quick' condition may develop in the soil and very low N values may be recorded. In spite of all these imperfections, SPT is still extensively used because the test is simple and relatively economical.

It is the only test that provides representative soil samples both for visual inspection in the field and for natural moisture content and classification tests in the laboratory. SPT values obtained in the field for sand have to be corrected before they are used in empirical correlations and design charts. IS: 2131-1981 recommends that the field value of N be corrected for two effects, namely, (a) effect of overburden pressure, and (b) effect of dilatancy.

Correction for overburden pressure:

Several investigators have found that the penetration resistance or the N value in a granular soil is influenced by the overburden pressure. Of two granular soils possessing the same relative density but having different confining pressures, the one with a higher confining pressure gives a higher N value. Since the confining pressure (which is directly proportional to the overburden pressure) increases with depth, the N values at shallow depths are underestimated and the N values at larger depths are overestimated. To allow for this, N values recorded from field tests at different effective overburden pressures are corrected to a standard effective overburden pressure.

Static cone penetration test:

At field SCPT is widely used of recording variation in the in-situ penetration resistance of soil in cases where in-situ density is disturbed by boring method & SPT is unreliable below water table. The test is very useful for soft clays, soft silts, medium sands & fine sands.

Procedure:

By this test basically by pushing the standard cone at the rate of 10 to 20 mm/sec in to the soil and noting the friction, the strength is determined.

After installing the equipment as per IS-4968, part III the sounding rod is pushed in to the soil and the driving is operated at the steady rate of 10 mm/sec approximately so as to advance the cone only by external loading to the depth which a cone assembly available. For finding combine cone friction resistance, the shearing strength of the soil q_s , and tip resistance q_c is noted in gauge & added to get the total strength

Limitations

This test is unsuitable for gravelly soil & soil for having SPT N value greater than 50. Also in dense sand anchorage becomes to cumbersome & expensive & for such cases Dynamic SPT can be used. This test is also unsuitable for field operation since erroneous value obtained due to presence of brick bats, loose stones etc.

Geophysical exploration General Overview Geophysical exploration may be used with advantage to locate boundaries between different elements of the subsoil as these procedures are

based on the fact that the gravitational, magnetic, electrical, radioactive or elastic properties of the different elements of the subsoil may be different. Differences in the gravitational, magnetic and radioactive properties of deposits near the surface of the earth are seldom large enough to permit the use of these properties in exploration for civil engineering projects. However, the resistivity method based on the electrical properties and the seismic refraction method based on the elastic properties of the deposits has been used widely in large civil engineering projects.

Dynamic Cone penetration Test

The dynamic cone penetration is performed in the same way as SPT except that there is no bore hole for DCPT. This test is performed in two ways.

➤ Without bentonite Slurry

In this test, a 50 mm diameter 60° cone fitted to driving rod is driven into the soil by a 65 kg hammer falling freely from a height of 750 mm. Blow count of every 100 mm penetration is recorded. The number of blows required for 300 mm penetration is termed as the dynamic cone resistance N_{cd} .

$$N_{cd} = 1.5 \text{ N for depths } < 3 \text{ m}$$

$$N_{cd} = 1.75 \text{ N for depths from 3 to 6 m}$$

$$N_{cd} = 2.0 \text{ N for depths } > 6 \text{ m}$$

➤ With bentonite Slurry

A DCPT with bentonite slurry is conducted to eliminate the surface frictional resistance on the drill rods. In this test a 62.5 mm diameter 60° cone is driven into the ground with an arrangement for the mud to flow through the cone. The number of blows required for 300 mm penetration of 62.5 mm diameter cone is denoted as N_{cbr} . The use of bentonite slurry may not be necessary when investigation is up to a depth of 6 m only. CBRI, Roorkee has given the following relations between N_{cbr} and N .

Without bentonite slurry

$$N_{cbr} = 1.5 \text{ N for depths up to 4 m}$$

$$N_{cbr} = 1.75 \text{ N for depths from 4 to 9 m}$$

$$N_{cbr} = 2.0 \text{ N for depths } > 9 \text{ m}$$

With bentonite slurry

$$N_{cbr} = N$$

Static Cone Penetration Test (SCPT)

This test consists of pushing a cone into the ground at a steady rate of 20 mm/s either manually or using some power mechanism. The cone used in this test has a base area of 1000mm^2 and an apex angle of 60° . The cone is screwed to the sounding rod which passes through hollow casing tube of 36 mm external diameter. The resistance, the soil offers, to 100 mm penetration of the cone is termed as static cone penetration resistance q_c .

Firstly, the penetration resistance of cone alone is recorded. Next, the sleeve around the drill rod is pushed down to the level of the cone and both the cone as well as sleeve are then pushed together into the soil to a depth of 100 mm and the combined resistance is recorded.

If

Q_c = Total force required to push the cone alone to a distance of 100 mm in the ground

Q_t = Total force required to push the cone and the friction jacket to a distance of 100 mm in the ground

A_c = Base area of cone

A_t = Surface area of friction jacket

f_c = Local side friction

Then

$$q_c = Q_c/A_c$$

Pressure meter Test

The borehole pressure meter test is an in situ test where a carefully prepared borehole that is sufficiently—but not over about 10 percent—oversized is used. The pressure meter probe consisting of three parts (top, cell, and bottom) as shown in figure above is then inserted and expanded to and then into the soil. The top and bottom guard cells are expanded to reduce end-condition effects on the middle (the cell) part, which is used to obtain the volume versus cell pressure relationship used in data reduction.

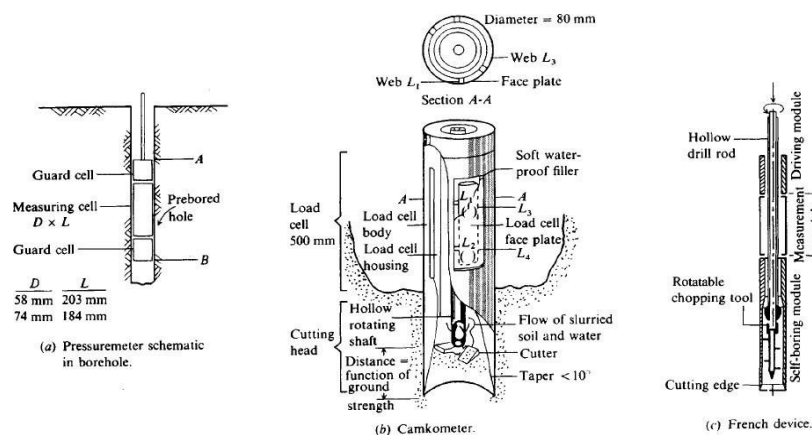

Different methods of geophysical explorations 1 Electrical resistivity method:

Electrical resistivity method is based on the difference in the electrical conductivity or the electrical resistivity of different soils. Resistivity is defined as resistance in ohms between the opposite phases of a unit cube of a material.

$$\rho = \left(\frac{RA}{L} \right)$$

ρ is resistivity in ohm-cm,

R is resistance in ohms,

A is the cross sectional area (cm²),

L is length of the conductor (cm).

Procedure

In this method, the electrodes are driven approximately 20cms in to the ground and a dc or a very low frequency ac current of known magnitude is passed between the outer (current) electrodes, thereby producing within the soil an electrical field and the boundary conditions. The electrical potential at point C is V_c and at point D is V_d which is measured by means of the inner (potential) electrodes respectively.

$$V_c = \frac{I\rho}{2\pi} \left(\frac{1}{r_1} - \frac{1}{r_2} \right) \quad \text{-----(1.1.1)}$$

$$V_d = \frac{I\rho}{2\pi} \left(\frac{1}{r_3} - \frac{1}{r_4} \right) \quad \text{-----(1.1.2)}$$

where,

ρ is resistivity,

I is current,

r_1, r_2, r_3 and r_4 are the distances between the various electrodes as shown in fig. 1.13.

$$\text{Potential difference between C and D} = V_{cd} = V_c - V_d = \frac{I\rho}{2\pi} \left[\left(\frac{1}{r_1} - \frac{1}{r_2} \right) - \left(\frac{1}{r_3} - \frac{1}{r_4} \right) \right]$$

$$\rho = \frac{2\pi V_{cd}}{I} \left[\frac{1}{\left(\frac{1}{r_1} - \frac{1}{r_2} \right) - \left(\frac{1}{r_3} - \frac{1}{r_4} \right)} \right]$$

$$\rho = \frac{2\pi R r_1}{I}$$

If $r_1 = r_4 = (r_2/2) = (r_3/2)$ then resistivity is given as,

where, Resistance $R = (V_{CD} / I)$

Thus, the apparent resistivity of the soil to a depth approximately equal to the spacing r_1 of the electrode can be computed. The resistivity unit is often so designed that the apparent resistivity can be read directly on the potentiometer.

In —resistivity mapping or —transverse profiling the electrodes are moved from place to place without changing their spacing, and the apparent resistivity and any anomalies within a depth equal to the spacing of the electrodes can thereby be determined for a number of points.

Approximately equal to the spacing r_1 of the electrode can be computed. The resistivity unit is often so designed that the apparent resistivity can be read directly on the potentiometer.

In —resistivity mapping or —transverse profiling the electrodes are moved from place to place without changing their spacing, and the apparent resistivity and any anomalies within a depth equal to the spacing of the electrodes can thereby be determined for a number of points.

Seismic refraction method:

General:

This method is based on the fact that seismic waves have different velocities in different types of soils (or rock) and besides the wave refract when they cross boundaries between different types of soils. In this method, an artificial impulse are produced either by detonation of explosive or mechanical blow with a heavy hammer at ground surface or at the shallow depth within a hole. These shocks generate three types of waves. Longitudinal or compressive wave or primary (p) wave, Transverse or shear waves or secondary

(s) wave, Surface waves.

It is primarily the velocity of longitudinal or the compression waves which is utilized in this method. The equation for the velocity of the p-waves (V_c) and s-waves (V_s) is given as,

$$V_c = \sqrt{\frac{E(1-\mu)}{(1+\mu)(1-2\mu)\rho}}$$

----- (1.2.1)

$$V_s = \sqrt{\frac{E}{2\rho(1+\mu)}}$$

----- (1.2.2)

Where,

E is the dynamic modulus of the soil,

μ is the Poisson's ratio,

ρ is density and,

G is the dynamic shear modulus.

These waves are classified as direct, reflected and refracted waves. The direct wave travel in approximately straight line from the source of impulse. The reflected and refracted wave undergoes a change in direction when they encounter a boundary separating media of different seismic velocities (Refer fig. 1.19). This method is more suited to the shallow explorations for

civil engineering purpose. The time required for the impulse to travel from the shot point to various points on the ground surface is determined by means of geophones which transform the vibrations into electrical currents and transmit them to a recording unit or oscillograph, equipped with a timing mechanism.

Field Vane Shear Testing

The vane shear test VST is a substantially used method to estimate the in situ undrained shear strength of very soft, sensitive, fine-grained soil deposits. The FVST is closely related to the laboratory consolidated-undrained shear strength test. Vane blades are on the order of 1.5 to 2.5 mm thick, the shaft body is from about 12.7 to 22 mm in diameter, and the tip is sharpened using a 45° cut (90°vee). The dimensions are selected to minimize soil disturbance from its insertion—but there is always a small amount (on the order of 15 to 25 percent) of strength loss. The torque is usually applied through a suitable gearing device so that a rate of about 6° of rotation per minute can be achieved. This test has been standardized by ASTM as D 2573, which allows either a rectangular or a tapered vane and specifies the ratio of $h/d = 2$. The generalized test torque for a rectangular shaped vane can be written as

$$T = \pi \left(\frac{s_{u,vv} d^2 h}{2} + \frac{s_{u,vh} a d^3}{4} \right)$$

where d, h = diameter and height of vane blades and in the ratio $h/d = 2$

a = constant for type of cylinder end shear assumed by user

$S_{u,vv}$ = shear in vertical plane from the perimeter of the vertical vane edges

$S_{u,vh}$ = shear in horizontal plane from the horizontal (or tapered) vane edges. For a tapered vane this is a combination of the vertical and horizontal shear strengths

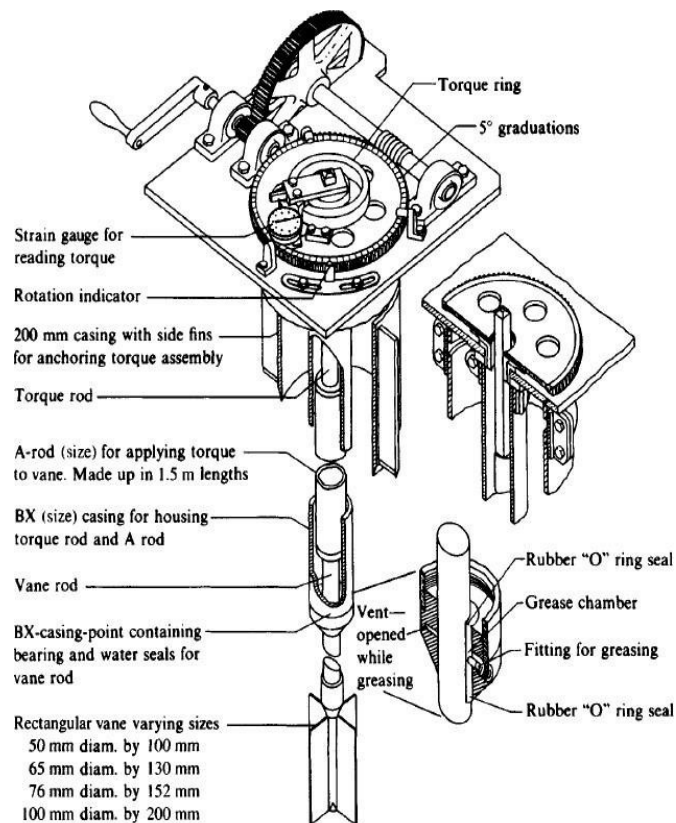

Preparation of Boring Logs

- Name and address of the drilling company
- Driller's name
- Job description and number
- Number, type, and location of boring
- Date of boring
- Subsurface stratification, which can be obtained by visual observation of the soil brought out by auger, split-spoon sampler, and thin-walled Shelby tube sample.
- Elevation of water table and date observed, use of casing and mud losses, and so on
- Standard penetration resistance and the depth of SPT
- Number, type, and depth of soil sample collected
- In case of rock coring, type of core barrel used and, for each run, the actual length of coring, length of core recovery, and RQD

Boring Log

Name of the Project Two-story apartment building

Location Johnson & Olive St. Date of Boring March 2, 1982

Boring No. 3 Type of Hollow stem auger Boring Ground Elevation 60.8 m

Soil description	Depth (m)	Soil sample type and number	N	w_n (%)	Comments
Light brown clay (fill)					
Silty sand (SM)	1				
	2	SS-1	9	8.2	
*C.W.T.  3.5 m Light gray silty clay (ML)	3	SS-2	12	17.6	LL = 38 PI = 11
	4				
Sand with some gravel (SP)	5	ST-1		20.4	LL = 36 $q_u = 112 \text{ kN/m}^2$
	6	SS-3	11	20.6	
End of boring @ 8 m	7				
	8	SS-4	27	9	
N = standard penetration number (below/304.8 mm) w_n = natural moisture content LL = liquid limit; PI = plasticity index q_u = unconfined compression strength SS = split-spoon sample; ST = Shelby tube sample				*Ground water table observed after one week of drilling	

Geotechnical Design Reports

At the end of all subsoil exploration programs, the soil and/or rock specimens collected from the field are subjected to visual observation and appropriate laboratory testing. After the compilation of all of the required information, a soil exploration report is prepared for the use of the design office and for reference during future construction work. Although the details and sequence of information in the report may vary to some degree is depending on the structure under consideration and the person compiling the report.

Subsoil Exploration Report

- A description of the scope of the investigation
- A description of the proposed structure for which the subsoil exploration has been conducted.
- A description of the location of the site, including any structures nearby, drainage conditions, the nature of vegetation on the site and surrounding it, and any other features unique to the site
- A description of the geological setting of the site.
- Details of the field exploration—that is, number of borings, depths of borings, types of borings involved, and so on
- A general description of the subsoil conditions, as determined from soil specimens and from related laboratory tests, standard penetration resistance and cone penetration resistance, and soon
- A description of the water-table conditions
- Re commendations regarding the foundation, including the type of foundation recommended, the allowable bearing pressure, and any special construction procedure that may be needed; alternative foundation design procedures should also be discussed in this portion of the report.
- Conclusions and limitations of the investigations

The following graphical presentations should be attached to the report:

1. A site location map
2. A plan view of the location of the borings with respect to the proposed structures and those nearby
3. Boring logs
4. Laboratory test results
5. Other special graphical presentations

UNIT II

SLOPE STABILITY

Introduction

The term slope as used in here refers to any natural or manmade earth mass, whose surface forms an angle with the horizontal. Hills and mountains, river banks, etc. are common examples of natural slopes. Examples of manmade slopes include fills, such as embankments, earth dams, levees; or cuts, such as highway and railway cuts, canal banks, foundations excavations and trenches. Natural forces (wind, rain, earthquake, etc.) change the natural topography often creating unstable slopes. Failure of natural slopes (landslides) and manmade slopes have resulted in much death and destruction. In assessing the stability of slopes, geotechnical engineers have to pay particular attention to geology, drainage, groundwater, and the shear strength of the soils. The most common slope stability analysis methods are based on simplifying assumptions and the design of a stable slope relies heavily on experience and careful site investigation.

In this chapter, we will examine the stability of earth slopes in two dimensional space using limit equilibrium methods.

- Understand the causes and types of slope failure.
- Estimate the stability of slopes using limit equilibrium methods.

Sample Practical Situation: A reservoir is required to store water for domestic use. Several sites were investigated and the top choice is a site consisting of clay soils (clay is preferred because of its low permeability – it is practically impervious). The soils would be excavated, forming sloping sides. You are required to determine the maximum safe slope of the reservoir.

Slip plane or failure plane or slip surface or failure surface is the surface of sliding.

Sliding mass is the mass of soil within the slip plane and the ground surface.

Slope angle (or simply slope) is the angle of inclination of a slope to the horizontal. The slope angle is usually referred to as a ratio, for example, 2:1 (horizontal: vertical)

Some Types of Slope Failure

Slope failures depend on the soil type, soil stratification, groundwater, seepage, and the slope geometry. A few types of slope failure are shown in Figure. Failure of a slope along a weak zone of soil is called a **translational slide**. Translational slides are common in coarse-grained soils.

A common type of failure in homogeneous fine-grained soils is a rotational slide. Three types of rotational slides often occur. One type, called a base slide, occurs by an arc enclosing the whole

slope. A soft soil layer resting on a stiff layer of soil is prone to base failure. The second type of rotational failure is the toe slide, whereby the failure surface passes through the toe of the slope. The third type of rotational failure is the slope slide, whereby the failure surface passes through the slope. A flow slide occurs when internal and external conditions force a soil to behave like a viscous fluid and flow down even shallow slopes, spreading out in several directions.

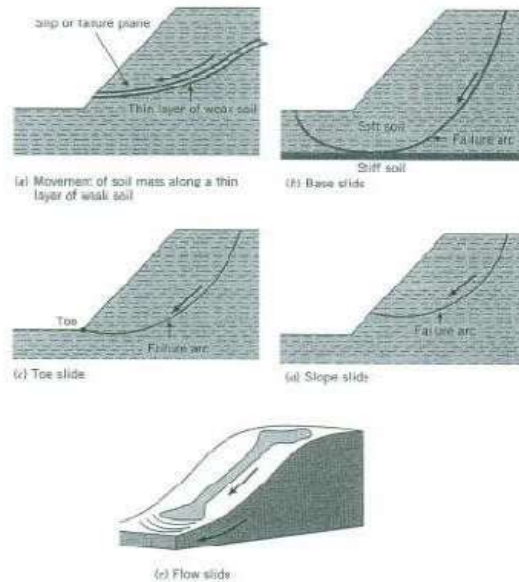

Fig. Some types of slope failure

Some Causes of Slope Failure: Slope failures are caused in general by natural forces, human mismanagement and activities. Some of the most common causes of slope failures are erosion, rainfall, earthquake, geological features, external loading, construction activities (ex. excavation & fill), and reservoir rapid drawdown.

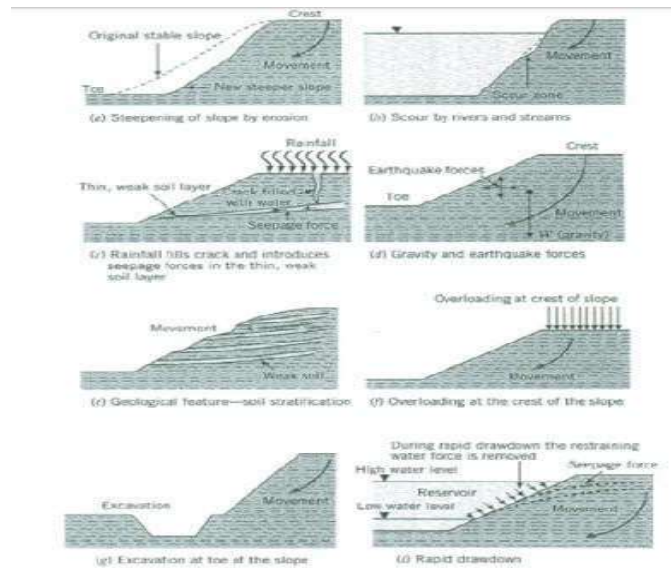

Fig. Some causes of slope failure

Two-Dimensional Slope Stability Analysis

Slope stability can be analyzed using one or more of the following: the limit equilibrium method, limit analysis, finite difference method, and finite element method. Limit equilibrium is the most widely used method for stability analysis. In the following sections, we will learn some of the commonly used slope stability analysis methods that are based on the limit equilibrium.

Stability Analysis of Infinite Slopes

Infinite slopes have dimensions that extend over great distances. In practice, the infinite slope mechanism is applied to the case when a soft material of very long length with constant slope may slide on a hard material (e.g. rock) having the same slope. Let's consider a clean, homogeneous soil of infinite slope α s as shown in Fig. To use limit equilibrium method, we must first speculate on a failure of slip mechanism. We will assume the slip would occur on a plane parallel to the slope. If we consider a slice of soil between the surface of the soil and the slip plane, we can draw a free-body diagram of the slice as shown in Fig.

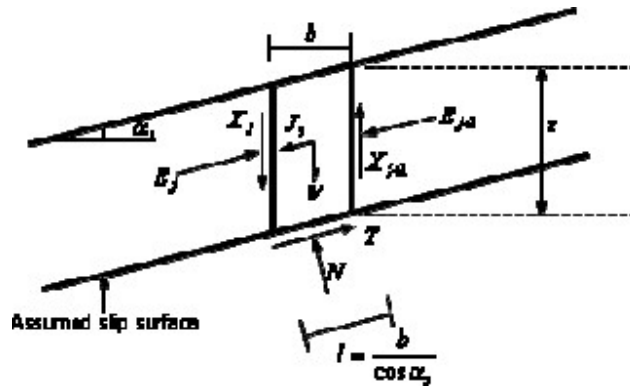

Fig. Forces on a slice of soil in an infinite slope.

The forces acting on the slice per unit thickness are the weight $W = \gamma b z$, the shear forces X_j and X_{j+1} on the sides, the normal forces E_j and E_{j+1} on the sides, the normal force N on the slip plane and the mobilized shear resistance of the soil, T , on the slip plane. We will assume that forces that provoke failure are positive. If seepage is present, a seepage force $J_s = i \gamma_w b z$ develops, where i is the hydraulic gradient. For a uniform slope of infinite extent, $X_j = X_{j+1}$ and $E_j = E_{j+1}$. To continue with the limit equilibrium method, we must now use the equilibrium equations to solve the problem. But before that we will define the factor of safety (FS) of a slope in the following subsection. The general objective of infinite slope stability analysis is to determine either the critical slope or critical height, or alternatively, the factor of safety of the slope.

Factor of Safety: The factor of safety of a slope is defined as the ratio of the available shear strength, τ_f , to the minimum shear strength required to maintain stability (which is equal to the mobilized shear stress on the failure surface), τ_m , that is:

$$FS = \frac{\tau_f}{\tau_m}$$

The shear strength of the soil is governed by the Mohr-Coulomb failure criterion.

Stability of Infinite Slopes in $\phi_u = 0$, c_u soil.

For the $\phi_u = 0, c_u$ soil, the Mohr-Coulomb shear strength is given by:

$$\tau_f = c_u$$

From statics and using Figure 4.3,

$$N = W \cos \alpha_s \text{ and } T = W \sin \alpha_s$$

The shear stress per unit length on the slip plane is given by:

$$\tau_m = \frac{T}{l} = \frac{W \sin \alpha_s \cos \alpha_s}{b} = \frac{\gamma b z}{b} \sin \alpha_s \cos \alpha_s = \gamma z \sin \alpha_s \cos \alpha_s$$

The factor of safety is then,

$$FS = \frac{c_u}{\gamma z \sin \alpha_s \cos \alpha_s} = \frac{2c_u}{\gamma z \sin(2\alpha_s)}$$

At limit equilibrium, FS = 1. Therefore, the **critical slope** is

$$\alpha_c = \frac{1}{2} \sin^{-1} \left(\frac{2c_u}{\gamma z} \right)$$

and the **critical depth** is:

$$z_c = \frac{2c_u}{\gamma \sin(2\alpha_s)}$$

Stability of Infinite Slopes in c', ϕ' soil – with no seepage.

For a c', ϕ' soil, the Mohr-Coulomb shear strength is given by:

$$\tau_f = c' + \sigma'_n \tan \phi'$$

The factor of safety FS is then:

$$FS = \frac{c' + \sigma'_n \tan \phi'}{\tau_m} = \frac{c'}{\tau_m} + \frac{\sigma'_n \tan \phi'}{\tau_m}$$

Rotational Slope Failure: The infinite slope failure mechanism is reasonable for infinitely long and homogeneous slopes made of coarse-grained soils, where the failure plane is assumed to be parallel to the ground surface. But in many practical problems slopes have been observed to fail through a rotational mechanism of finite extent. Rotational failure mechanism involves the failure of a soil mass on a circular or non-circular failure surface. In the following sections, we will continue to use the limit equilibrium method assuming a circular slip surface.

Stability of Slopes in $c_u, \phi_u = 0$ soil – circular failure surface.

The simplest circular analysis is based on the assumption that a rigid, cylindrical block will fail by rotation about its center and that the shear strength along the failure surface is defined by the undrained strength c_u . Figure shows a slope of height H and angle α_s . The trial circular failure surface is defined by its center C, radius R and central angle θ .

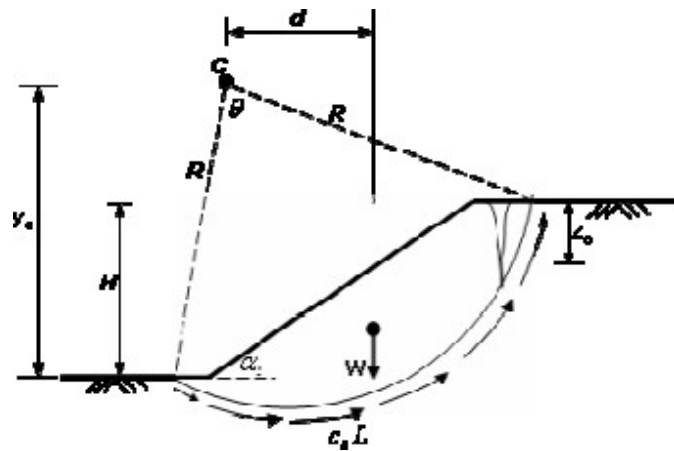

Slope failure in $c_u, \phi_u = 0$.

The weight of the sliding block acts at a distance d from the center. Taking moments of the forces about the center of the circular arc, we have:

$$FS = \frac{c_u LR}{Wd} = \frac{c_u R^2 \theta^0}{Wd} \times \frac{\pi}{180^0}$$

Where L is the length of the circular arc, W is the weight of the sliding mass and d is the horizontal distance between the circle center, C , and the centroid of the sliding mass. If c_u varies along the failure surface then:

$$FS = \frac{R^2 (c_{u1} \theta_1^0 + c_{u2} \theta_2^0 + \dots + c_{un} \theta_n^0)}{Wd} \times \frac{\pi}{180^0}$$

The centroid of the sliding mass is obtained using a mathematical procedure based on the geometry or the sub-division of the sliding mass into narrow vertical slices.

Stability of Slopes in c', ϕ' soil – Method of Slices.

The stability of a slope in a c', ϕ' soil is usually analyzed by discretizing the mass of the failure slope into smaller slices and treating each individual slice as a unique sliding block. This technique is called the method of slices.

In the method of slices, the soil mass above a trial failure circle is divided into a series of vertical slices of width b . For each slice, its base is assumed to be a straight line defined by its angle of

The term $c'l$ may be replaced by $c'b/\cos\theta$. For uniform c' , the algebraic summation of $c'l$ is replaced by $c'L$, where L is the length of the circular arc. The values of N' must be determined from the force equilibrium equations. However, this problem is statically indeterminate – because we have six unknown variables for each slice but only three equilibrium equations. Therefore some simplifying assumptions have to be made. In this chapter two common methods that apply different simplifying methods will be discussed. These methods are called the Fellenius method and Bishop simplified method.

Fellenius or Ordinary or Swedish Method

The ordinary or Swedish method of slices was introduced by Fellenius (1936). This method assumes that for each slice, the interslice forces $X_1=X_2$ and $E_1=E_2$. Based on this assumption and from statics, the forces normal to each slice are given by:

$$N = W \cos \theta = N' + ul \quad \Rightarrow \quad N' = W \cos \theta - ul$$

Substituting N' into Eqn. 4.21, we obtain:

$$FS = \frac{\sum_{i=1}^{i=n} [(c'l + (W \cos \theta - ul) \tan \phi')]}{\sum_{i=1}^{i=n} (W \sin \theta)_i}$$

For convenience, the force due to pore water is expressed as a function of W :

$$r_u = \frac{u_i b_i}{W_i}$$

Where r_u is called the pore water pressure ratio. Consequently, we have:

$$FS = \frac{\sum_{i=1}^{i=n} [(c'l + W (\cos \theta - r_u \sec \theta) \tan \phi')]}{\sum_{i=1}^{i=n} (W \sin \theta)_i}$$

The term r_u is dimensionless because the term $ub = \gamma_w \times h_w \times b \times 1$ represents the weight of water with a volume of $h_w \times b \times 1$. Furthermore, r_u can be simplified as follows:

$$r_u = \frac{ub}{W} = \frac{\gamma_w h_w b}{\gamma h b} = \frac{\gamma_w h_w}{\gamma h} \quad (4.26)$$

In the case of the steady state seepage the height of water above the midpoint of the base is obtained by constructing the flow net. Alternatively, an average value of r_u may be assumed for the slope. By doing so it is assumed that the height of water above the base of each slice is a constant fraction of the height of each slice. If the height of the water and the average height of the slice are equal, the maximum value of r_u becomes γ_w/γ' which for most soils, is

approximately 0.5. Note that the effective normal force N' acting on the base is equal to $N' = W \cos\theta - ul$ or $(\cos\theta \sec\theta) N = W - ru$. If the term $(\cos\theta \sec\theta) N = W - ru$ is negative, N' is set to zero because effective stress cannot be less than zero (i.e. soil has no tension strength). The whole procedure explained above must be repeated for a number of trial circles until the minimum factor of safety corresponding to the critical circle is determined. The accuracy of the predictions depends on the number of slices, position of the critical surface, and the magnitude of ru . There are several techniques that are used to reduce the number of trial slip surfaces. One simple technique is to draw a grid and selectively use the nodal points as centers of rotation.

Bishop Simplified Method

This method assumes that for each slice $X_1 = X_2$ but $E_1 \neq E_2$. These assumptions are considered to make this method more accurate than the Swedish method. An increase of 5% to 20% in the factor of safety over the Swedish method is usually obtained. Referring to Figure 4.6 b, and writing the force equilibrium in vertical direction (in order to eliminate E_1 and E_2), the following equation for N' can be found:

$$N' = \frac{W - ul \cos\theta - \frac{c'l \sin\theta}{FS}}{\cos\theta + \frac{\sin\theta \tan\phi'}{FS}}$$

In addition to the force in the vertical direction, Bishop Simplified method also satisfies the overall moment equilibrium about the center of the circle as expressed in Eqn.. Putting $l = b / \cos\theta$ and $ub = ruW$, and substituting we obtain:

$$FS = \frac{l}{\sum_{i=1}^{i=n} (W \sin\theta)_i} \sum_{i=1}^{i=n} \left[\frac{c'b + W(1 - r_u) \tan\phi'}{m_\theta} \right]_i$$

where,

$$m_\theta = \cos\theta + \frac{\sin\theta \tan\phi'}{FS}$$

Above equation is non-linear in FS (that is FS appears on both sides of the equations) and is solved by iteration. An initial value of FS is guessed (slightly greater than FS obtained by Fellenius' method) and substituted to above Eqn. to compute a new value for FS. This procedure is repeated until the difference between the assumed and computed values is negligible. Convergence is normally rapid and only a few iterations are required. The procedure is repeated for number of trial circles to locate the critical failure surface with the lowest factor of safety.

UNIT III

EARTH PRESSURE THEORIES & RETAINING WALLS

Introduction: A retaining wall is a structure that is used to support a vertical or near vertical slopes of soil. The resulting horizontal stress from the soil on the wall is called lateral earth pressure. To determine the magnitude of the lateral earth pressure, a geotechnical engineer must know the basic soil parameters – that is, unit weight γ , angle of friction ϕ , and cohesion c for the soil retained behind the wall. In the evaluation of the magnitude of this lateral earth pressure, it is assumed that the soil behind the wall (called backfill soil) is on the verge of failure and obeys some failure criterion, for example, the Mohr-Coulomb failure criterion.

At rest earth pressure coefficient (k_0) is the ratio between the lateral and vertical principal effective stresses when an earth retaining structure is at rest (or is not allowed to move at all).

Active earth pressure coefficient (k_a) is the ratio between the lateral and vertical principal effective stresses when an earth retaining structure moves away from the retained soil.

Passive earth pressure coefficient (k_p) is the ratio between the lateral and vertical principal effective stresses when an earth retaining structure is forced to move against a soil mass.

Lateral Earth Pressure at Rest Consider a vertical wall of height H , as shown in Fig, retaining a soil having a unit weight of γ . At any depth z below the ground surface the vertical effective stress is:

$$\sigma'_v = \gamma z - u$$

If the wall is not allowed to move at all either way from the soil mass or to the soil mass (or in other words if there is no lateral expansion or compression in the backfill soil), the lateral pressure is called at rest earth pressure. In this case, the lateral earth pressure σ'_x at a depth z is:

$$\sigma'_x = k_0 \sigma'_z$$

where k_0 is coefficient of at rest earth pressure. You must remember that k_0 applies only to effective stresses not to total stresses. The magnitude of k_0 depends on the type of the soil, its degree of compaction, plasticity characteristics, and degree of disturbance.

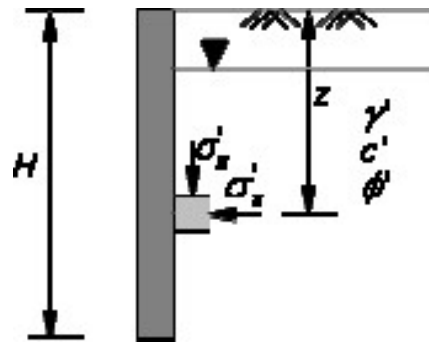

At rest Earth Pressure

For truly normally consolidated soil that exhibits zero cohesion, a value for k_0 may be calculated from the following generally accepted empirical equation:

$$k_0 = 1 - \sin\phi$$

Active and Passive Lateral Earth Pressures

The lateral earth pressure condition described involves walls that do not yield at all. In this section, we will discuss other conditions that involve movement of the wall and consequently failure of the backfill soil. Failure of the backfill soil occurs by two mechanisms depending on the direction of wall displacement. If the displacement of the wall is away from the backfill soil the resulting failure is called active and the lateral pressure exerted on the wall by the backfill soil is called active lateral earth pressure or simply active earth pressure. A passive failure occurs if the wall is displaced towards the backfill soil until the limiting displacement is achieved. In this case, the wall exerts a pressure on the backfill soil, and the passive resistance provided by the backfill soil against the wall displacement is called passive earth pressure

Rankine Active and Passive Earth Pressures

Consider a vertical frictionless (smooth) wall retaining a soil mass in both front and back of the wall as shown in Fig. If the wall remains rigid and no movement occurs, then the vertical and horizontal (lateral) effective stresses at rest on element A, at the back of the wall, and B, at the front of the wall are given by Eqns. Mohr's circle for the at rest state is shown by circle. Let us now assume a rotation about the bottom of the wall sufficient to produce slip planes in the soil mass behind and in front of the wall. The soil mass at the back of the wall is assisting in producing failure, thus

The stress states of soil elements A and B are called the Rankine active state and the Rankine passive state, respectively (Named after the first developer of this theory Rankine, 1857). Each of these Rankine states is associated with a family of failure planes. For the Rankine active state, the

failure planes are oriented at:

$$\theta_a = 45^\circ + \frac{\phi'}{2}$$

For the Rankine passive state, the failure planes are oriented at:

$$\theta_p = 45^\circ - \frac{\phi'}{2}$$

Rankine active lateral effective stress is:

$$\begin{aligned}\sigma'_a &= \sigma'_z \frac{1 - \sin \phi'}{1 + \sin \phi'} - 2c' \sqrt{\frac{1 - \sin \phi'}{1 + \sin \phi'}} \\ &= \sigma'_z k_a - 2c' \sqrt{k_a}\end{aligned}$$

where,

$$k_a = \frac{1 - \sin \phi'}{1 + \sin \phi'} = \tan^2 \left(45 - \frac{\phi'}{2} \right)$$

is called the active earth pressure coefficient.

For the passive state, the lateral effective stress ' σ_p ' becomes the major principal stress ' σ_1 ' and the vertical effective stress ' σ_z ' becomes the minor principal stress ' σ_3 '

Rankine passive lateral effective stress is:

$$\begin{aligned}\sigma'_p &= \sigma'_z \frac{1 + \sin \phi'}{1 - \sin \phi'} + 2c' \sqrt{\frac{1 + \sin \phi'}{1 - \sin \phi'}} \\ &= \sigma'_z k_p + 2c' \sqrt{k_p}\end{aligned}$$

where,

$$k_p = \frac{1 + \sin \phi'}{1 - \sin \phi'} = \tan^2 \left(45 + \frac{\phi'}{2} \right)$$

K_p is called the passive earth pressure coefficient. we can easily get the following relation for the active and passive earth pressure coefficients:

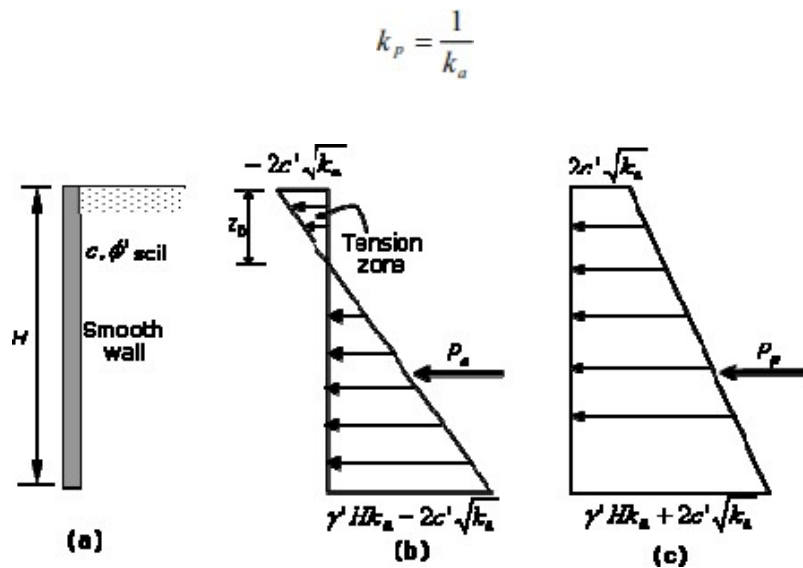

Pressure distribution in $c-\phi'$ soil: a) $c-\phi'$ soil, b) active, c) passive state.

Figure shows the active and passive lateral stress distribution for a smooth wall retaining a $c-\phi'$ soil. In the active state case, the soil at depth $z = 0$ is subjected to a tensile stress. Soils do not have tensile strength, as a result tension cracks will occur down to a depth z_0 , where the tensile stress becomes zero. At depth z_0 (known as depth of tension crack), the stress is zero, thus,

$$0 = \gamma z_0 k_a - 2c' \sqrt{k_a} \Rightarrow z_0 = \frac{2c'}{\gamma \sqrt{k_a}} \quad (3.13)$$

The lateral earth force is the area of the lateral stress diagram (Fig. 3.5), which for the Rankine active state, is:

$$P_a = \int_0^H (\gamma z k_a - 2c' \sqrt{k_a}) = \frac{1}{2} k_a \gamma H^2 - 2c' H \sqrt{k_a} \quad (3.14)$$

and, for the Rankine passive state, is

$$P_p = \int_0^H (\gamma z k_p + 2c' \sqrt{k_p}) = \frac{1}{2} k_p \gamma H^2 + 2c' H \sqrt{k_p} \quad (3.15)$$

For most retaining wall construction, a granular backfill is used and $c' = 0$, therefore, for granular soils Eqns. (3.13) and (3.14) can be rewritten as:

$$P_a = \frac{1}{2} k_a \gamma H^2 \quad (3.16)$$

$$P_p = \frac{1}{2} k_p \gamma H^2$$

Lateral Earth Pressure due to Surcharge

Surfaces stresses (due to surcharge) also impose lateral pressure on retaining walls as illustrated in Fig. A uniform surface stress, q_s , will transmit a uniform active lateral earth pressure of $k_a q_s$ and a uniform passive lateral earth pressure of $k_p q_s$. The active and passive lateral stresses due to the soil (i.e. c', ϕ' soil), and the uniform surfaces stresses are then:

$$\sigma'_a = k_a \gamma' z + k_a q_s \quad (3.18)$$

$$\sigma'_p = k_p \gamma' z + k_p q_s \quad (3.19)$$

The corresponding active and passive lateral forces are also given by:

$$P_a = \frac{1}{2} k_a \gamma' H^2 + k_a q_s H \quad (3.20)$$

and

$$P_p = \frac{1}{2} k_p \gamma' H^2 + k_p q_s H \quad (3.21)$$

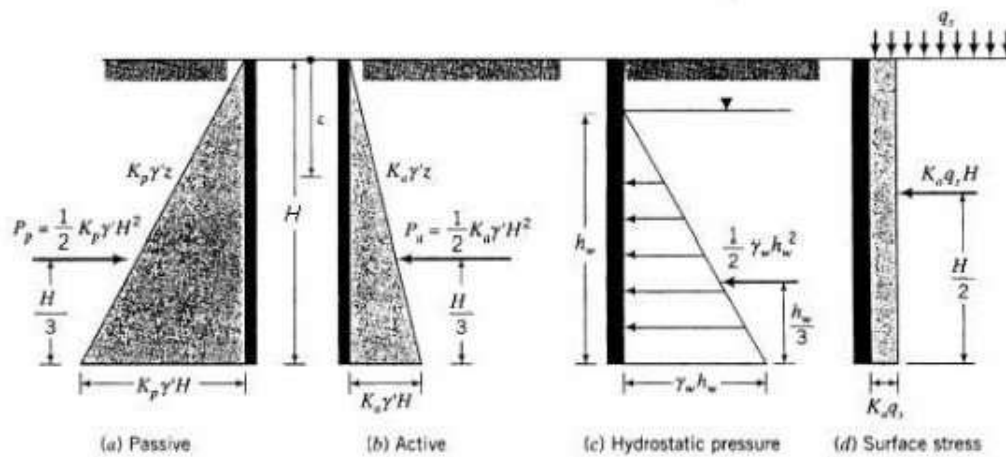

For a c', ϕ' backfill, Eqns. (3.18) and (3.19) will become:

$$\sigma'_a = k_a \gamma' z + k_a q_s - 2c' \sqrt{k_a} \quad (3.22)$$

and

$$\sigma'_p = k_p \gamma' z + k_p q_s + 2c' \sqrt{k_p} \quad (3.23)$$

The corresponding active and passive lateral forces are also given by:

$$P_a = \frac{1}{2} k_a \gamma' H^2 + k_a q_s H - 2c' H \sqrt{k_a} \quad (3.24)$$

and

$$P_p = \frac{1}{2} k_p \gamma' H^2 + k_p q_s H + 2c' H \sqrt{k_p} \quad (3.25)$$

Note that for a purely cohesive saturated clay with undrained shear strength parameter of c_u and $\phi'_u = 0$, $k_a = k_p = 1$.

Summary of Rankine Lateral Earth Pressure Theory

- The lateral earth pressures on retaining walls are related directly to the vertical effective stress through two coefficients k_a and k_p .
- Substantially more movement is required to mobilize the full passive earth pressure than the full active earth pressure.
- A family of slip planes occurs in the Rankine active and passive states. In the active state, the slip planes are oriented at $(45 + \phi/2)'$ to the horizontal, and while for the passive case they are oriented at $(45 - \phi/2)'$ to the horizontal.
- The lateral earth pressure coefficients, developed so far are only valid for a smooth, vertical wall supporting a soil mass with a horizontal surface; and must be applied to effective stresses only

Coulomb's Earth Pressure Theory

As described in the previous sections, the Rankine earth pressure theory: Assumes the retaining wall is frictionless (or smooth), and considers stress states and uses such tools as the Mohr's circle of stress. Coulomb (1776) proposed a theory to determine the lateral earth pressure on a retaining wall by assuming a granular backfill ($c = 0$) and a plane sliding surface. He did this in order to simplify somewhat the mathematically complex problem introduced when cohesion and non plane sliding surfaces are considered. He, however, account for the effects of friction (usually expressed by angle δ) between the backfill and the wall. Besides, he considered the more general case of the sloped face of a retaining wall, and in this respect, Coulomb's theory is a more general approach than the Rankine theory described earlier.

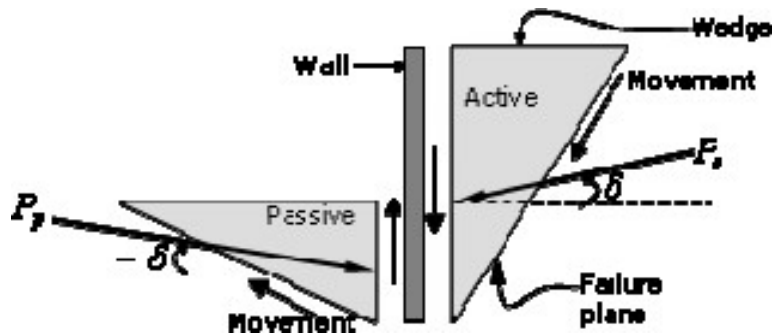

Coulomb assumed a wedge shape collapse mechanism which is bounded by the face of the retaining wall, a horizontal or inclined ground surface and a linear failure plane. The wedge slides downwards on the failure plane in the active state or upwards in the passive state.

Based on Coulomb's theory, a condition of limit equilibrium exists through which a wedge of a soil mass behind a retaining wall will slip along a plane inclined at an angle θ to the horizontal. A retaining wall with sloping back, wall friction, and sloping soil surface for use with Coulomb's method for active state. Based on the equilibrium of the forces acting on the wedge, Coulomb proposed the following equation to determine the active lateral force.

$$P_a = \frac{1}{2} k_{ac} \gamma H^2 \quad (3.32)$$

where k_{ac} is Coulomb's active pressure coefficient, which is determined by the following expression.

$$k_{ac} = \frac{\sin^2(\beta + \phi')}{\sin^2 \beta \sin(\beta - \delta) \left[1 + \sqrt{\frac{\sin(\phi' + \delta) \sin(\phi' - \alpha)}{\sin(\beta - \delta) \sin(\alpha + \beta)}} \right]^2} \quad (3.33)$$

Note that the line of action of the active force P_a will act at a distance $H/3$ above the base of the wall and will be inclined at angle δ to the normal drawn to the back of the wall. In the actual design of retaining walls, the value of the wall friction angle, δ , is assumed to be between $\phi/2$ and $2/3\phi$. Retaining walls are generally constructed of masonry or mass concrete. Table 3.1 shows the general range of the values of δ for various backfill materials.

Table 3.1: General range of wall friction angle for masonry or mass concrete walls

Backfill material	Range of δ in degrees
Gravel	27 - 30
Course sand	20 - 28
Fine sand	15 - 25
Stiff clay	15 - 20
Silty clay	12 - 16

Coulomb's passive earth pressure is determined similarly, except that passive pressure inclination at the wall and direction of the forces acting on the wedge Coulomb's passive earth pressure is given by:

$$P_a = \frac{1}{2} k_{pc} \gamma H^2 \quad (3.34)$$

where k_{pc} is Coulomb's passive pressure coefficient, which is determined by the following equation.

$$k_{pc} = \frac{\sin^2(\beta - \phi')}{\sin^2 \beta \sin(\beta + \delta) \left[1 - \frac{\sin(\phi' + \delta) \sin(\phi' + \alpha)}{\sin(\beta + \delta) \sin(\alpha + \beta)} \right]^2} \quad (3.35)$$

Retaining Wall

Retaining walls are structures used to retain earth or water or other materials such as coal, ore, etc; where conditions do not permit the mass to assume its natural slope. The retaining material is usually termed as backfill. The main function of retaining walls is to stabilize hillsides and control erosion. When roadway construction is necessary over rugged terrain with steep slopes, retaining walls can help to reduce the grades of roads and the land alongside the road. Some road projects lack available land beside the travel way, requiring construction right along the toe of a slope. In these cases extensive grading may not be possible and retaining walls become necessary to allow for safe construction and acceptable slope conditions for adjacent land uses. Where soils are unstable, slopes are quite steep, or heavy runoff is present, retaining walls help to stem erosion. Excessive runoff can undermine roadways and structures, and controlling sediment runoff is a major environmental and water quality consideration in road and bridge projects. In these situations, building retaining walls, rather than grading excessively, reduces vegetation removal and reduces erosion caused by runoff. In turn, the vegetation serves to stabilize the soil and filter out sediments and pollutants before they enter the water source, thus improving water quality.

In this section you will learn the following

- Gravity walls

- Semi Gravity Retaining Wall
- Flexible walls

- Special type of retaining walls

Different Types of Retaining Structures On the basis of attaining stability, the retaining structures are classified into following:

1. Gravity walls :

Gravity walls are stabilized by their mass. They are constructed of dense, heavy materials such as concrete and stone masonry and are usually reinforced. Some gravity walls do use mortar, relying solely on their weight to stay in place, as in the case of dry stone walls. They are economical for only small heights.

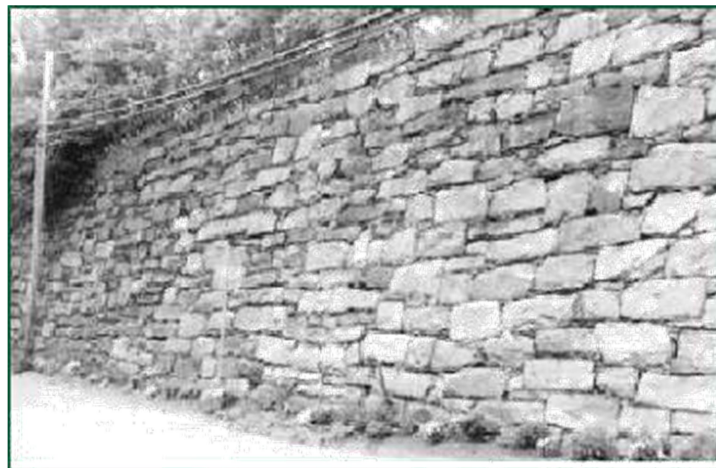

Semi Gravity Retaining Wall

These walls generally are trapezoidal in section. This type of wall is constructed in concrete and derives its stability from its weight. A small amount of reinforcement is provided for reducing the mass of the concrete. This can be classified into two:

This is a reinforced concrete wall which utilises cantilever action to retain the backfill. This type is suitable for retaining backfill to moderate heights (4m-7m). In cross section most cantilevered walls look like. To ensure stability, they are built on solid foundations with the base tied to the vertical portion of the wall with reinforcement rods. The base is then backfilled to counteract forward pressure on the vertical portion of the wall. The cantilevered base is reinforced and is designed to prevent uplifting at the heel of the base, making the wall strong and stable. Local

building codes, frost penetration levels and soil qualities determine the foundation and structural requirements of taller cantilevered walls. Reinforced concrete cantilevered walls sometimes have a batter. They can be faced with stone, brick, or simulated veneers. Their front faces can also be surfaced with a variety of textures. Reinforced Concrete Cantilevered Walls are built using forms. When the use of forms is not desired, Reinforced Concrete Block Cantilevered Walls are another option. Where foundation soils are poor, Earth Tieback Retaining Walls are another choice. These walls are counterbalanced not only by a large base but also by a series of horizontal bars or strips extending out perpendicularly from the vertical surface into the slope. The bars or strips, sometimes called —deadmen are made of wood, metal, or synthetic materials such as geotextiles. Once an earth tieback retaining wall is backfilled, the weight and friction of the fill against the horizontal members anchors the structure.

Counterfort retaining wall

When the height of the cantilever retaining wall is more than about 7m, it is economical to provide vertical bracing system known as counter forts. In this case, both base slab and face of wall span horizontally between the counter forts.

3. **Flexible walls:** there are two classes of flexible walls.

A. Sheet pile walls and

B. Diaphragm wall

A. Sheet Pile Walls

Sheet piles are generally made of steel or timber. The use of timber piles is generally limited to temporary structures in which the depth of driving does not exceed 3m. for permanent structures and for depth of driving greater than 3m, steel piles are most suitable. Moreover, steel piles are relatively water tight and can be extracted if required and reused. However, the cost of sheet steel piles is generally more than that of timber piles. Reinforced cement concrete piles are generally used when these are to be jettied into fine sand or driven in very soft soils, such as peat. For tougher soils, the concrete piles generally break off. Based on its structural form and loading system, sheet pile walls can be classified into 2 types: (i) Cantilever Sheet Piles and (ii) Anchored Sheet Piles

1. Cantilever sheet pile walls:

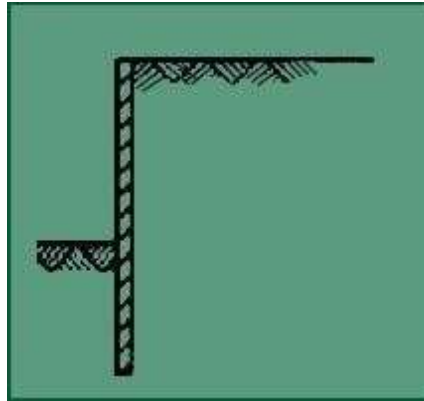

Cantilever sheet pile wall

Cantilever sheet piles are further divide into two types:

Free cantilever sheet pile

It is a sheet pile subjected to a concentrated horizontal load at its top. There is no back fill above the dredge level. The free cantilever sheet pile derives its stability entirely from the lateral passive resistance of the soil below the dredge level into which it is driven.

1. Cantilever Sheet Pile Wall with Backfill

A cantilever sheet pile retains backfill at a higher level on one side. The stability is entirely from the lateral passive resistance of the soil into which the sheet pile is driven, like that of a free cantilever sheet pile.

2. **Anchored sheet pile walls** Anchored sheet pile walls are held above the driven depth by anchors provided ata suitable level. The anchors provided for the stability of the sheet pile, in addition to the lateral passive resistance of the soil into which the sheet piles are driven. The anchored sheet piles are also of two types.

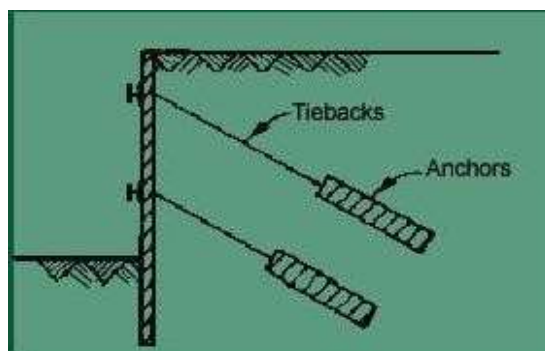

Anchored sheet pile wall

- **Free earth support piles.** An anchored pile is said to have free earth support when the depth of embedment is small and the pile rotates at its bottom tip. Thus there is a point of contra flexure in the pile.
- **Fixed earth support piles.** An anchored sheet pile has fixed earth support when the depth of embedment is large. The bottom tip of the pile is fixed against rotations. There is a change in the curvature of the pile, and hence, an inflection point occurs.
- **Diaphragm Walls** Diaphragm walls are commonly used in congested areas for retention systems and permanent foundation walls. They can be installed in close proximity to existing structures, with minimal loss of support to existing foundations. In addition, construction dewatering is not required, so there is no associated subsidence. Diaphragm walls have also been used as deep groundwater barriers through and under dams.

Diaphragm walls are constructed by the slurry trench technique which was developed in Europe, and has been used in the United States since the 1940's. The technique involves excavating a narrow trench that is kept full of an engineered fluid or slurry. The slurry exerts hydraulic pressure against the trench walls and acts as shoring to prevent collapse. Slurry trench excavations can be performed in all types of soil, even below the ground water table. Cast in place; diaphragm walls are usually excavated under bentonite slurry. The construction sequence usually begins with the excavation of discontinuous primary panels. Some pipes are placed vertically in each end of the primary panels, to form joints for adjacent secondary panels. Panels are usually 8 to 20 feet long, with widths varying from 2 to 5 feet. Once the excavation of a panel is complete, a steel reinforcement cage is placed in the center of the panel. Concrete is then poured in one continuous operation, through one or several tremie pipes that extend to the bottom of the trench. The tremie pipes are extracted as the concrete raises in the trench, however the discharge of the tremie pipe always remains embedded in the fresh concrete. The slurry, which is displaced by the concrete, is saved and reused for subsequent panel excavations. When the concrete sets, the end pipes are withdrawn. Similarly, secondary panels are constructed between the primary panels, and the process continues to create a continuous wall. The finished walls may cantilever or require anchors or props for lateral support.

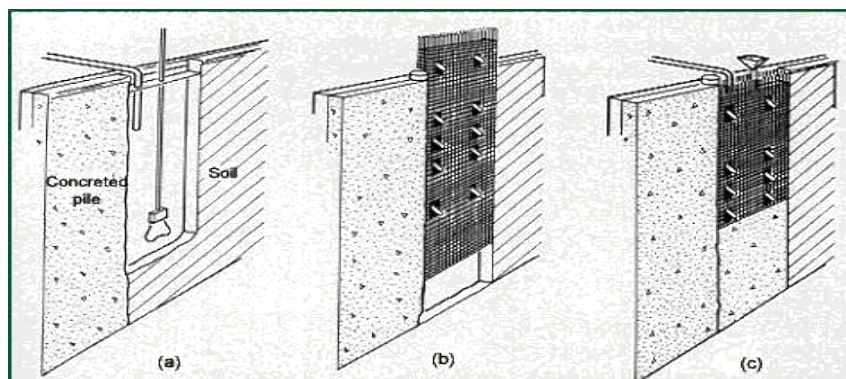

First decide which theory we want to apply for calculating the active earth pressure. Normally we calculate earth pressure using Rankine's theory or Coulomb's Earth pressure theory.

For using Rankine's theory, a vertical line AB is drawn through the heel point (Fig 6.12-b). It is assumed that the Rankine active condition exist along the vertical line AB. While checking the stability, the weight

of the soil (W_s) above the heel in the zone ABC should also be taken in to consideration, in addition to the Earth pressure (P_a) and weight of the wall (W_c). But Coulomb's theory gives directly the lateral pressure (P_a) on the back face of the wall, the forces to be considered only P_a (Coulomb) and the Weight of the wall (W_c). In this case, the weight of soil (W_s) is need not be considered.

Once the forces acting on the wall have been determined, the Stability is checked using the procedure discussed in the proceeding section. For convenience, the section of the retaining wall is divided in to rectangles & triangles for the computation of the Weight and the determination of the line of action of the Weight.

For a safe design, the following requirement must be satisfied.

No Sliding

Horizontal forces tend to slide the wall away from the fill. This tendency is resisted by friction at the base.

$$F.S_{\text{sliding}} = \frac{\sum \text{Resisting Force } (\sum V)}{\sum \text{Sliding Force } (\sum H)} > 1.5 (\text{for Stability}) \quad (\text{General})$$

$$F.S_{\text{sliding}} = \frac{[\mu \sum W] + P_p \cdot \cos(\delta)}{P_a \cdot \cos(\delta)}$$

$$F.S_{\text{sliding}} = \frac{\mu \cdot W_c + \mu [P_a \cdot \sin(\delta)] + P_p \cdot \cos(\delta)}{P_a \cdot \cos(\delta)} \quad \therefore [\mu = \tan(\delta)] \quad (\text{Coulomb})$$

μ = Coefficient of friction between the base of the wall and soil (= $\tan \delta$)

$\sum W$ = Sum of the all vertical forces i.e. vertical component of inclined active force.

A minimum factor of safety of 1.5 against sliding is recommended.

No Overturning

The wall must be safe against overturning about toe.

No Bearing Capacity Failure and No Tension

First calculate the line of action of the Resultant force (e) from centre of the base.

(No Tension will develop at the heel)

$$\bar{X} = \frac{[\sum M_R] - [\sum M_0] \text{ (net moment)}}{\sum V \text{ (vertical force)}}$$

$$\text{Therefore } [e = \frac{B}{2} - \bar{X}] \leq \frac{B}{6}$$

The pressure at the toe of the wall must not exceed the allowable bearing capacity of the soil. The pressure at the base is assumed to be linear. The max. Pressure at the Toe & min at the Heel is given by:

$$P_{(max)} = \frac{\sum V}{B} \left(1 + \frac{6e}{B} \right) \quad P_{min} = \frac{\sum V}{B} \left(1 - \frac{6e}{B} \right)$$

$P_{(max)}$ should be less than the Safe bearing capacity(q_{allow}) of the soil & $P_{(max)}$ should not be Tensile in any case. Tension is not desirable. The tensile strength of the soil is very small and tensile crack would develop. The effective base area is reduced.

$$F.S._{\text{bearing capacity}} = \frac{q_{\text{allowable}}}{P_{max}} \geq 2.5$$

UNIT IV

SHALLOW FOUNDATION

Introduction

A foundation is an integral part of the structure which transfers the load of the superstructure to the soil. A foundation is that member which provides support for the structure and its loads. It includes the soil and rock of earth's crust and any special part of structure that serves to transmit the load into the rock or soil.

The different types of the foundations are given in fig. 4.1

Different types of footings

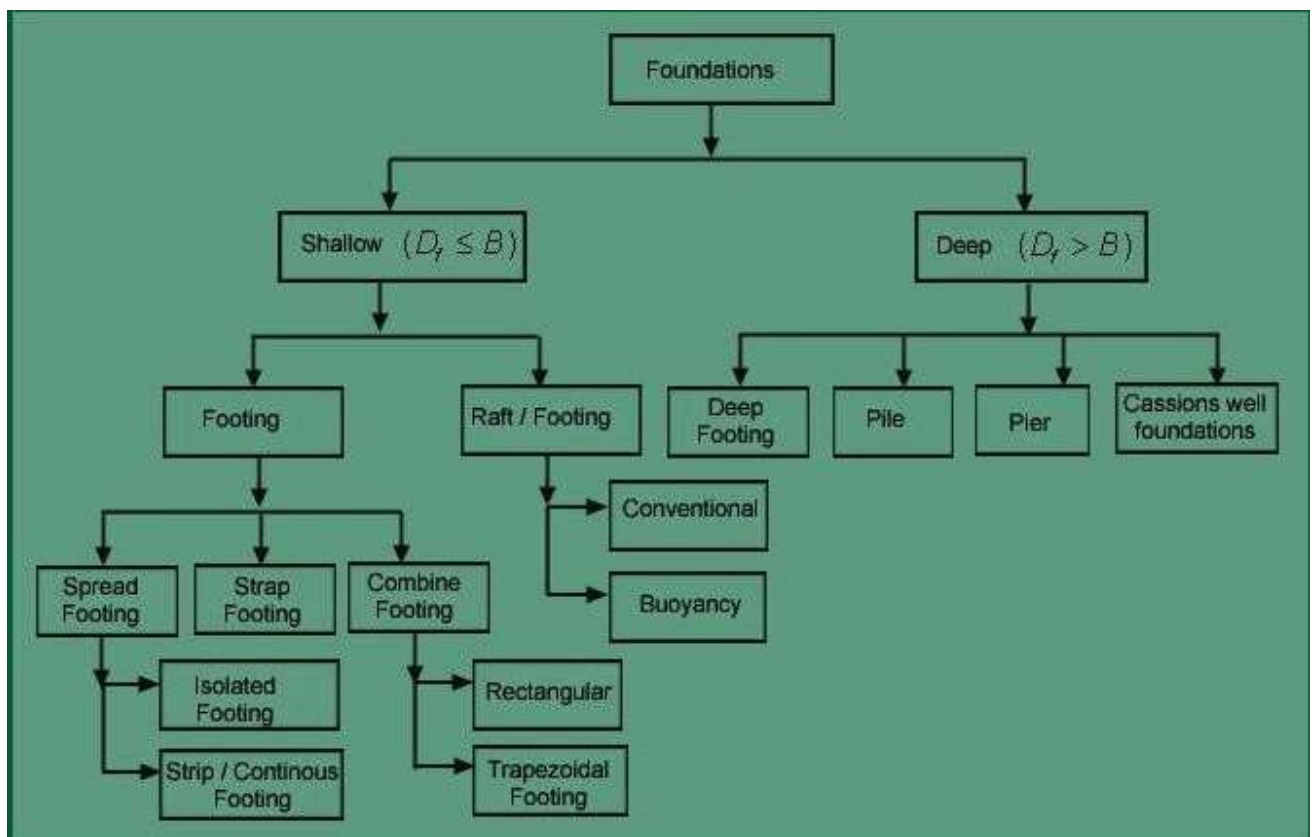

Fig. 4.1 Different types of footings

- **Ultimate Bearing capacity (q_u)** Maximum gross intensity of loading that the soil can support against shear failure is called ultimate bearing capacity.

- **Net Ultimate Bearing Capacity (q_{nu}):** Maximum net intensity of loading that the soil can support at the level of foundation.

$$q_{nu} = q_u - \gamma D_f$$

- **Net Safe Bearing capacity (q_{ns}):** Maximum net intensity of loading that the soil can safely support without the risk of shear failure.

$$q_{ns} = q_{nu} / \text{FOS}$$

- **Gross Safe Bearing capacity:** Maximum gross intensity of loading that the soil can safely support without the risk of shear failure

$$q_{gs} = q_{ns} + \gamma D$$

- **Safe Bearing Pressure:** Maximum net intensity of loading that can be allowed on the soil without settlement exceeding the permissible limit.

- **Allowable Bearing Pressure:** Maximum net intensity of loading that can be allowed on the soil with no possibility of Minimum of capacity and shear failure or settlement exceeding the permissible limit.

Bearing Failure Modes

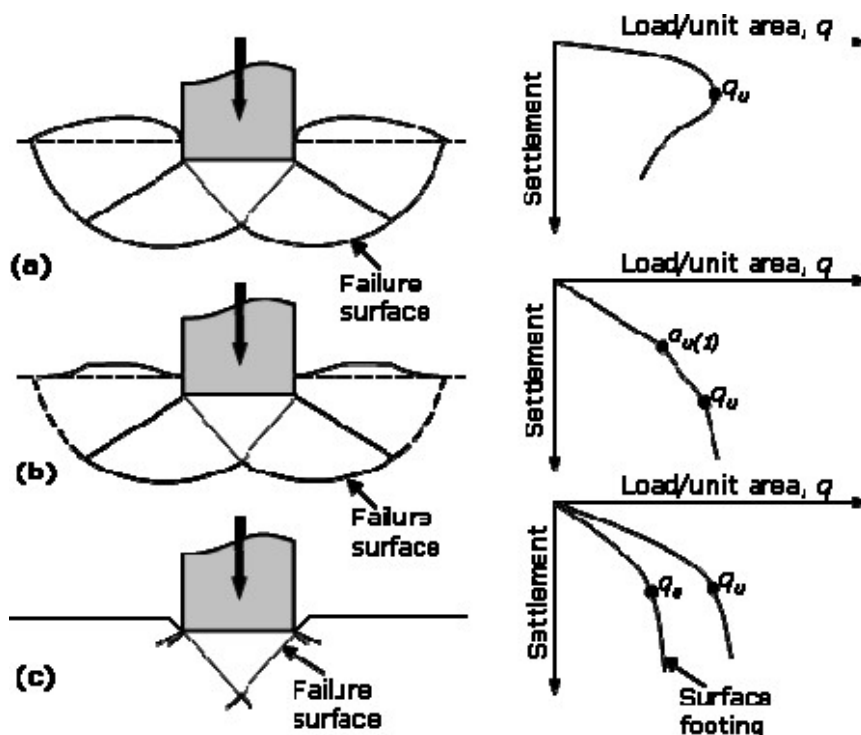

Relative density of the soil and size of the foundation are among the major factors that affect the mode of bearing failure likely to occur. The modes of bearing failure are generally separated into three categories: The general shear failure is usually associated with soils of low compressibility such as dense sand and stiff cohesive soils. In this case, if load is gradually applied to the foundation, settlement will increase. At a certain point – when the applied load per unit area equals to the ultimate load q_u – a sudden failure in the soil supporting the foundation will take place. The failure surface in the soil will extend to the ground surface and full shear resistance of the soil is developed along the failure surface. Bulging of the soil near the footing is usually apparent. For the local shear failure, which is common in sands and clays of medium compaction, the failure surface will gradually extend outward from the foundation but will not reach the ground surface as shown by the solid segment. The shear resistance is fully developed over only part of the failure surface (solid segment of the line). There is a certain degree of bulging of the soil. In the case of punching shear failure, a condition common in loose and very compressible soils, considerable vertical settlement may take place with the failure surfaces restricted to vertical planes immediately adjacent to the sides of the foundation; the ground surface may be dragged down. After the first yield has occurred the load-settlement curve will be steep slightly, but remain fairly flat.

TERZAGHI BEARING CAPACITY

Terzaghi (1943) was the first to propose a comprehensive theory for evaluating the safe bearing capacity of shallow foundation with rough base. He extended the theory of Prandtl.

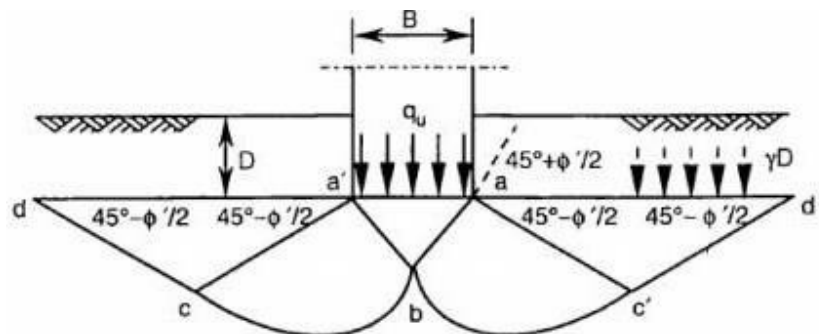

Assumptions

1. Soil is semi infinite, homogeneous and Isotropic.
2. The shear strength of soil is represented by Mohr Coulombs Criteria.
3. The footing is of strip footing type with rough base. It is essentially a two dimensional plane strain problem.
4. Elastic zone has straight boundaries inclined at an angle equal to ϕ to the horizontal.
5. Failure zone is not extended above, beyond the base of the footing. Shear resistance of soil

above the base of footing is neglected.

6. Method of superposition is valid.
7. Passive pressure force has three components (P_{pc} produced by cohesion, P_{pq} produced by surcharge and $P_{p\gamma}$ produced by weight of shear zone).
8. Effect of water table is neglected.
9. Footing carries concentric and vertical loads.
10. Footing and ground are horizontal.
11. Limit equilibrium is reached simultaneously at all points. Complete shear failure is mobilized at all points at the same time.
12. The properties of foundation soil do not change during the shear failure

Limitations

1. The theory is applicable to shallow foundations
2. As the soil compresses, increases which is not considered. Hence fully plastic zone may not develop at the assumed.
3. All points need not experience limit equilibrium condition at different loads.
4. Method of superposition is not acceptable in plastic conditions as the ground is near failure zone.

Terzhagi (1943) improved the Prandtl equation to include the roughness of the footing and the weight of the failure zone. The failure mechanism in a c' , ϕ' soil for Terzhagi's bearing capacity solution is shown in Fig. Terzhagi's ultimate bearing capacity equations are given as follows:

The ultimate load per unit area of the foundation (that is, the ultimate bearing capacity(q_u) for a soil with cohesion, friction, and weight can now be given as

$$\text{Strip (or long) footing: } q_u = c' N_c + \gamma D N_q + 0.5 B \gamma N_\gamma \quad (2.1)$$

$$\text{Square footing: } q_u = 1.3 c' N_c + \gamma D N_q + 0.4 B \gamma N_\gamma \quad (2.2)$$

$$\text{Circular footing: } q_u = 1.3 c' N_c + \gamma D N_q + 0.3 B \gamma N_\gamma \quad (2.3)$$

where N_c , N_q and N_γ are called the bearing capacity factors and are obtained as follows:

$$N_q = \frac{e^{(3\pi/2 - \phi') \tan \phi'}}{2 \cos^2 (45 + \phi'/2)}, \quad N_c = \cot \phi' (N_q - 1), \quad N_\gamma = \frac{1}{2} \tan \phi' \left(\frac{K_{p\gamma}}{\cos^2 \phi'} - 1 \right) \quad (2.4)$$

Meyerhof's Bearing Capacity equation: Meyerhof (1951) developed a bearing capacity equation by extending Terzhagi's failure mechanism and taking into account the effects of

footing shape, load inclination and footing depth by adding the corresponding factors of s, d, and i. For a rectangular footing of L by B (L > B) and inclined load

$$q_u = c' N_c s_c i_c d_c + \gamma D N_q s_q i_q d_q + 0.5 B \gamma N_\gamma s_\gamma i_\gamma d_\gamma$$

For vertical load, $i_c = i_q = i_\gamma = 1$

$$q_u = c' N_c s_c d_c + \gamma D N_q s_q d_q + 0.5 B \gamma N_\gamma s_\gamma d_\gamma$$

The bearing capacity factors:

$$N_q = \exp(\pi \tan \phi') \tan^2(45 + \phi'/2), \quad N_c = \cot \phi' (N_q - 1), \quad N_\gamma = (N_q - 1) \tan(1.4\phi') \quad (2.9)$$

In the undrained conditions (c_u and $\phi_u = 0$):

$$N_q = 1, \quad N_c = (\pi + 2) = 5.71, \quad N_\gamma = 0$$

The bearing capacity factors are graphically presented in Fig. 2.4. The shape, inclination and depth factors are according to:

	Shape	Depth	Inclination
Any ϕ'	$s_c = 1 + 0.2 K_p \frac{B}{L}$	$d_c = 1 + 0.2 \sqrt{K_p} \frac{D}{B}$	$i_c = i_q = \left(1 - \frac{\alpha^0}{90^0}\right)^2$
For $\phi' = 0$	$s_q = s_\gamma = 1$	$d_q = d_\gamma = 1$	$i_\gamma = 0$
For $\phi' \geq 10^0$	$s_q = s_\gamma = 1 + 0.1 K_p \frac{B}{L}$	$d_q = d_\gamma = 1 + 0.1 \sqrt{K_p} \frac{D}{B}$	$i_\gamma = \left(1 - \frac{\alpha^0}{\phi'^0}\right)^2$

$K_p = \tan^2\left(45 + \frac{\phi'}{2}\right), \quad \alpha = \text{angle of resultant measured from vertical axis.}$

when triaxial ϕ' is used for plane strain, adjust ϕ' to obtain $\phi' = \left(1.1 - 0.1 \frac{B}{L}\right) \phi'_{\text{triaxial}}$

For the eccentric load, the length and width of the footing rectangle are modified to: $L' = L - 2eL$ and $B' = B - 2eB$

where eL and eB represent the eccentricity along the appropriate directions.

Standard Penetration Test (SPT):

The Standard Penetration Test (SPT) is used to determine the allowable bearing capacity of cohesionless coarse-grained soils such as sands. The test procedure for SPT has been introduced in Chapter 1. The N values obtained from SPT are usually corrected for various effects such as overburden pressure and energy transfer. The following are two of the most commonly used methods in practice for correcting the N values.

$$c_N = \left(\frac{95.8}{\sigma'_{z0}} \right); \quad c_N \leq 2 \quad (\text{Liao and Whitman, 1985})$$

$$c_N = 0.77 \log_{10} \left(\frac{1916}{\sigma'_{z0}} \right); \quad c_N \leq 2, \quad \sigma'_{z0} > 24 \text{ kPa} \quad (\text{Peck et al., 1974})$$

where c_N is a correction factor for overburden pressure, and σ'_{z0} is the effective overburden pressure in kPa. A further correction factor is imposed on N values if the groundwater level is within a depth B below the base of the footing. The groundwater correction factor is:

$$c_W = \frac{1}{2} + \frac{z}{2(D+B)}$$

where z is the depth to the groundwater table, and D and B are the footing depth and width. If the depth of the groundwater table is beyond B from the footing base $c_W = 1$. The corrected N value is:

$$N_{\text{cor}} = c_N c_W N$$

Meyerhof (1956, 1974) proposed the following equations to determine the allowable bearing capacity q_a from SPT values.

$$q_a = \frac{12}{25} S_e N_{\text{cor}} k_d \quad B \leq 1.22 \text{ m}$$

$$q_a = \frac{8}{25} S_e N_{\text{cor}} \left(\frac{B+0.305}{B} \right)^2 k_d \quad B > 1.22 \text{ m}$$

where S_e is the elastic settlement of the layer in mm and $k_d = 1 + 0.33D/B \leq 1.33$. In practice, each value of N is a soil layer up to a depth B below the footing base is corrected and an average value of N_{cor} is used in Eqn. (2.37). Bowles (1996) modified Meyerhof's equations by 50% increase in the allowable bearing capacity. Bowles's equations are:

$$q_u = \frac{20}{25} S_e N_{cor} k_d \quad B \leq 1.22 \text{ m}$$

$$q_u = \frac{12.5}{25} S_e N_{cor} \left(\frac{B + 0.305}{B} \right)^2 k_d \quad B > 1.22 \text{ m}$$

Bearing Capacity from Plate load Test : It is a field test for the determination of bearing capacity and settlement characteristics of ground in field at the foundation level. The test involves preparing a test pit up to the desired foundation level. A rigid steel plate, round or square in shape, 300 mm to 750 mm in size, 25 mm thick acts as model footing. Dial gauges, at least 2, of required accuracy (0.002 mm) are placed on plate on plate at corners to measure the vertical deflection. Loading is provided either as gravity loading or as reaction loading. For smaller loads gravity loading is acceptable where sand bags apply the load. In reaction loading, a reaction truss or beam is anchored to the ground. A hydraulic jack applies the reaction load. At every applied load, the plate settles gradually. The dial gauge readings are recorded after the settlement reduces to least count of gauge (0.002 mm) & average settlement of 2 or more gauges is recorded. Load Vs settlement graph is plotted as shown. Load (P) is plotted on the horizontal scale and settlement is plotted on the vertical scale. The maximum load at which the shear failure occurs gives the ultimate bearing capacity of soil.

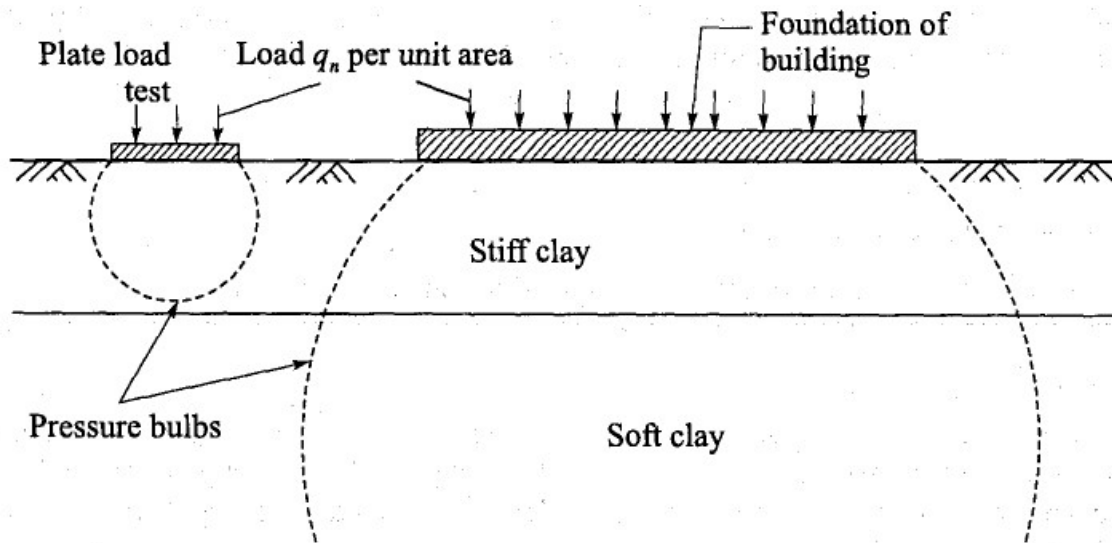

Fig. 6.2 (c) Plate load test on non-homogeneous soil

Since a load test is of short duration, consolidation settlements cannot be predicted. The test gives the value of immediate settlement only. If the underlying soil is sandy in nature immediate settlement may be taken as the total settlement. If the soil is a clayey type, the immediate settlement is only a fraction of the total settlement. Load tests, therefore, do not have much significance in clayey soils to determine allowable pressure on the basis of a settlement criterion.

Plate load tests should be used with caution and the present practice is not to rely too much on this test. If the soil is not homogeneous to a great depth, plate load tests give very misleading results.

Assume, as shown in Fig. 6.2 (c), two layers of soil. The top layer is stiff clay whereas the bottom layer is soft clay. The load test conducted near the surface of the ground measures the characteristics of the stiff clay but does not indicate the nature of the soft clay soil which is below. The actual foundation of a building however has a bulb of pressure which extends to a great depth into the poor soil which is highly compressible. Here the soil tested by the plate load test gives results which are highly on the unsafe side.

A plate load test is not recommended in soils which are not homogeneous at least to a depth equal to 1½ to 2 times the width of the prototype foundation.

Plate load tests should not be relied on to determine the ultimate bearing capacity of sandy soils as the scale effect gives very misleading results. However, when the tests are carried on clay soils, the ultimate bearing capacity as determined by the test may be taken as equal to that of the foundation since the bearing capacity of clay is essentially independent of the footing size.

Determination of bearing capacity from plate load test

The size effect has been empirically evolved in the form of the following equation (Terzaghi and Peck, 1948):

$$\frac{S}{S_p} = \left[\frac{b(b_p + 0.3)}{b_p(b + 0.3)} \right]^2 \quad \dots(\text{Eq. 14.110})$$

where S = settlement of the proposed foundation (mm),
 S_p = settlement of the test plate (mm),
 b = size of the proposed foundation (m), and
 b_p = size of the test plate (m).
] (same units)

This is applicable for sands.

However, the relationship is simpler for clays, since the modulus value E_s , for clays is reasonably constant:

$$\frac{S}{S_p} = \frac{b}{b_p} \quad \dots(\text{Eq. 14.111})$$

Allowable Bearing Capacity: The allowable bearing capacity shall be taken as either of the following, whichever is less: Net ultimate bearing capacity divided by suitable factor of safety, that is, net safe bearing capacity. The net soil pressure that can be imposed on the base without the settlement exceeding the permissible values as given in IS:1904-1978 to be determined for each structure and type of soil, that is, safe bearing pressure

DESIGN METHODOLOGY FOR PILES The detailed design methodology of piles is described in the following sections.

REQUIREMENT FOR DEEP FOUNDATIONS Generally for structures with load $>10 \text{ t/m}^2$ we go for deep foundations. Deep foundations are used in the following cases:

- Huge vertical load with respect to soil capacity.
- Very weak soil or problematic soil.
- Huge lateral loads eg. Tower, chimneys.
- Scour depth criteria.
- For fills having very large depth.
- Uplift situations (expansive zones)
- Urban areas for future large and huge construction near the existing building.

CLASSIFICATION OF PILES

1. Based on material

- Timber piles
- Steel piles
- Concrete piles
- Composite piles (steel + concrete)
- Driven piles
- Bored piles.
- Large displacement piles (occurs for driven piles)
- Small displacement piles (occurs for bored piles)

POINTS TO BE CONSIDERED FOR CHOOSING PILES

- Loose cohesion less soil develops much greater shaft bearing capacities if driven large displacement piles are used.
- Displacement effect enhanced by tapered shafts.
- Potential increased of shaft capacities is undesirable if negative friction is to be feared. (Negative friction is also called drag down force)

- High displacement piles are undesirable in stiff cohesive soils, otherwise excessive heaving takes place.
- Encountered with high artesian pressures on cased piles should be excluded. (Mainly for bridges and underwater construction)
- Driven piles are undesirable due to noise, damage caused by vibration, ground heaving. Heavy structures with large reactions require high capacity piles and small diameter cast-in-situ piles are inadequate.

Piles in clays

The ultimate load capacity of the pile is estimated by, $P_u = q_{bu} A_b + f_s A_s$

In clays, $q_{bu} = c_{ub} N_c$ and $c_u = \alpha c_u$; thus,

$$P_u = c_{ub} N_c A_b + \alpha c_u A_s$$

c_{ub} is the undrained cohesion at the base of the pile

N_c is the bearing capacity factor for deep foundation, generally taken as 9

α is the adhesion factor

c_u undrained cohesion in the embedded length of the pile

Pile load test

- Pile load test is the most reliable of all the approaches to determine the allowable load on the pile.
- Pile load test are very useful for cohesion less soil. However, incase of cohesive soils, the data from the pile load test should be used with caution on account of disturbance due to pile driving, development of pore pressure and the in adequate time allowed of consolidation settlement.
- Three types of pile tests are generally carried out.
 - Vertical load test
 - Lateral load test
 - Pull out test

IS: 2911 Part IV (1979) details the procedure for carrying out the load tests and assessing the allowable load. According to the code, the test shall be carried out by applying a series of vertical downward loads on a RCC cap over the pile. The load shall preferably be applied by means of a remote controlled hydraulic jack taking reaction against a loaded plot form. The test shall be applied in increments of about 20% of the assumed safe load. Settlement shall be

recorded with at least three dial gauges of sensitivity 0.02 mm. each stage of loading shall be maintained till the rate of movement of pile top is not more than 0.1 mm per hours which ever is later.

The loading shall be continued up to twice the safe load or the load at which the total settlement of the pile top/ cap equals the appropriate value as indicated in the criterion stated below:

- 2/3 the final load at which the total settlement attains a value of 12mm.
- Fifty percent of the final load at which the total settlement equals 10% of piles diameter in case of uniform diameter piles and 7.5% of bulb diameter in case of under reamed piles.

The allowable load on a group of piles shall be the lesser of the following:

- Final load at which the total settlement attains a value of 25mm, unless a total settlement different from 25mm is specified in a given case on the basis of the nature and type of structure.
- Two-thirds the final load at which the total settlement attains a value of 40 mm.

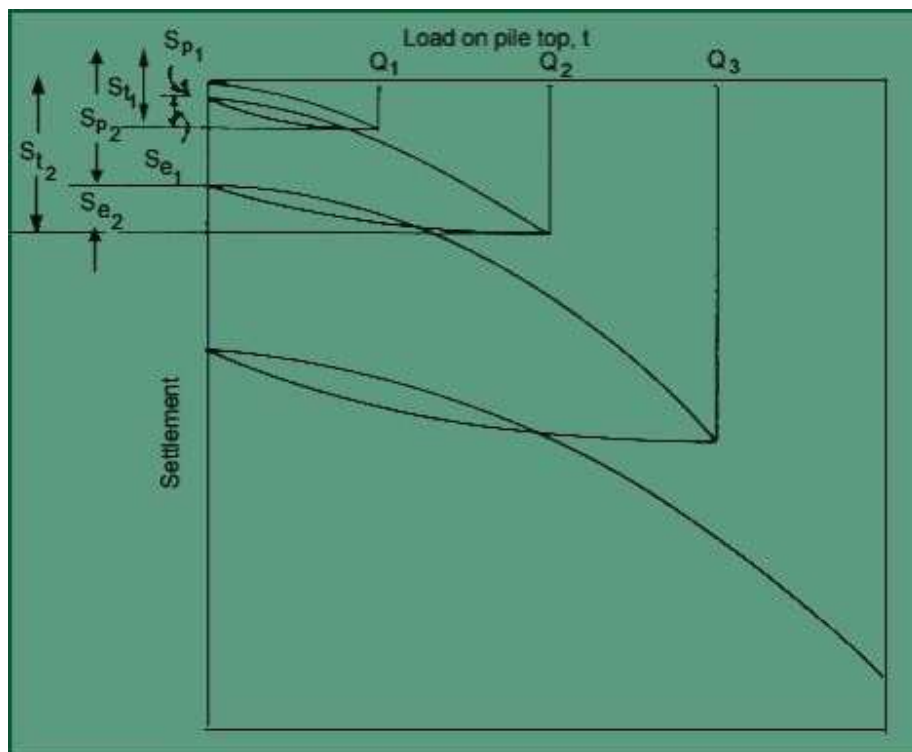

Load- Settlement plot from pile load test

The total settlement S of a pile obtained from a pile load test comprises of two components, namely, elastic settlement, S_e and plastic settlement, S_p .

$$S = S_e + S_p$$

The elastic settlement, S_e is due to the elastic recovery of the pile material and the elastic recovery of the soil at the base of the pile, S_e .

Dynamic formulae

These are based on the laws governing the impact of elastic bodies. The input energy of the hammer blow is equated to the work done in overcoming the resistance of the ground to the penetration of the pile. Allowance is made for the losses of energy due to elastic contractions of the pile, pile cap, and subsoil and also the losses due to the inertia of the pile.

- **Engineering news formula (A.M. Wellington)**

The dynamic resistance of soil or ultimate pile load capacity, $Q_u = \frac{WH}{F(S+C)}$

Where W is the weight of the hammer falling through a height H

S is the real set per blow

C is the empirical factor

F is the factor of safety say 6.

In metric units

Drop hammer, $Q_u = \frac{WH}{6(S+2.5)}$ -----(10)

Single acting steaming hammer, $Q_u = \frac{WH}{6(S+0.25)}$ -----(11)

Where Q_u & H are expressed in kg. H is in cm, S is the final set in cm/blow, usually taken as average penetration for the last 5 blows of a drop hammer, or 20 blows of a steam hammer.

UNIT V

WELL FOUNDATION

Well Foundation: Well foundation is a box of timber, metal, reinforced concrete or masonry which open both at the top and bottom, and is used for building for building and bridge foundations. Well foundations are being used in India from very early days. Taj Mahal was built on such foundations.

Well Caissons: It's a prefabricated hollow box or cylinder. It is sunk into the ground to some desired depth and then filled with concrete thus forming a foundation. Most often used in the construction of bridge piers & other structures that require foundation beneath rivers & other bodies of water.

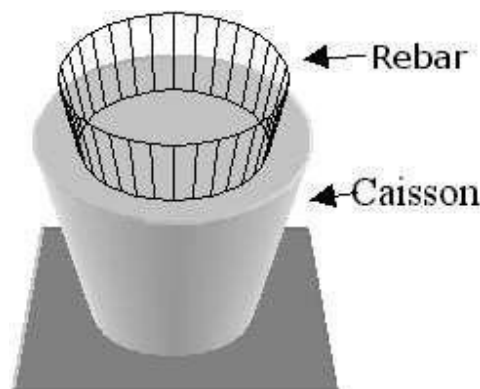

Types of Caisson

There are three types of caisson as follows:

- Open Caisson.
- Box Caisson.
- Pneumatic Caisson.

Depending upon their shape, **open caissons** can be further classified as,

- (i) Single wall open caisson
- (ii) Cylindrical open caisson
- (iii) Open caisson with dredging wells.

Single wall open caisson: This is a box type structure having no top or bottom (during construction) and mainly consists of vertical walls.

Cylindrical open caisson (well): This may be defined as a cylindrical shell made up of timber, masonry, steel or reinforced concrete shod with a cutting edge and which is sunk by excavating the soil within the shell.

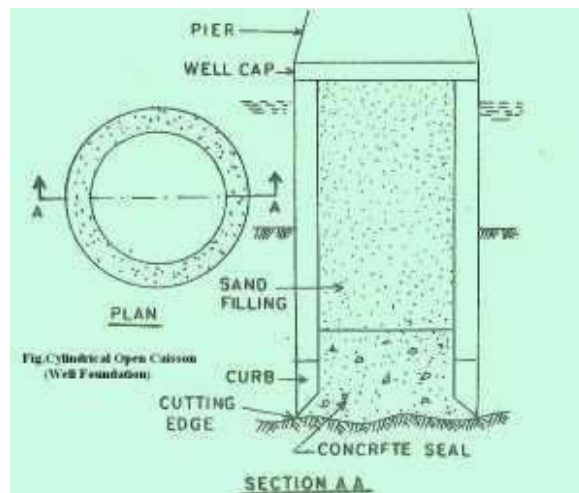

Open caisson with dredging wells: This type of caisson has the distinction of being employed for the deepest foundation for, bridge piers, abutments and other similar structures. The caisson in this case is rectangular or square in plan and is further sub-divided into smaller sections from inside forming open walls. The outside walls as well as the inside divider walls are normally made up of reinforced concrete.

Box caisson: This type of caisson is similar to open caisson except that it is closed at bottom. The caisson is cast and cured on land and when required, it is launched in water and towed to the site for sinking. The caisson is sunk by filling sand, gravel, or concrete in the empty space inside. The place where the caisson base is to rest must be leveled and as such box caissons are used in places where the strata of sufficient bearing capacity are available near the ground. In normal practice, the soft natural bottom soil of the river bed is dredged out to some depth and the trench thus formed is filled with sand to have a leveled base. The function of the sand layer is to uniformly distribute the superimposed loads over the soil below and thus avoid tilting of the caisson.

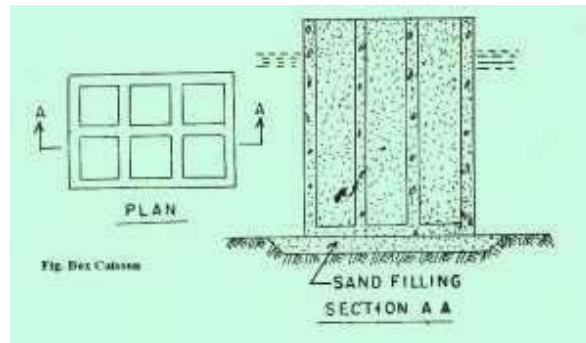

Pneumatic caisson:

This type of caisson is closed at top and open (during construction) at the bottom. The water is excluded from the caisson chamber by means of compressed air.

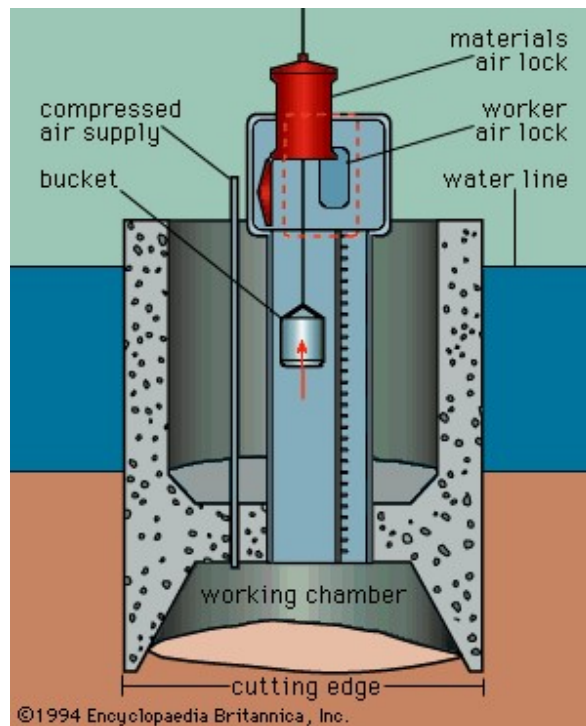

Types of well shapes:

- Circular well
- Rectangular well
- Double Rectangular well
- Double Octagonal well
- Double – D well
- Twin circular well

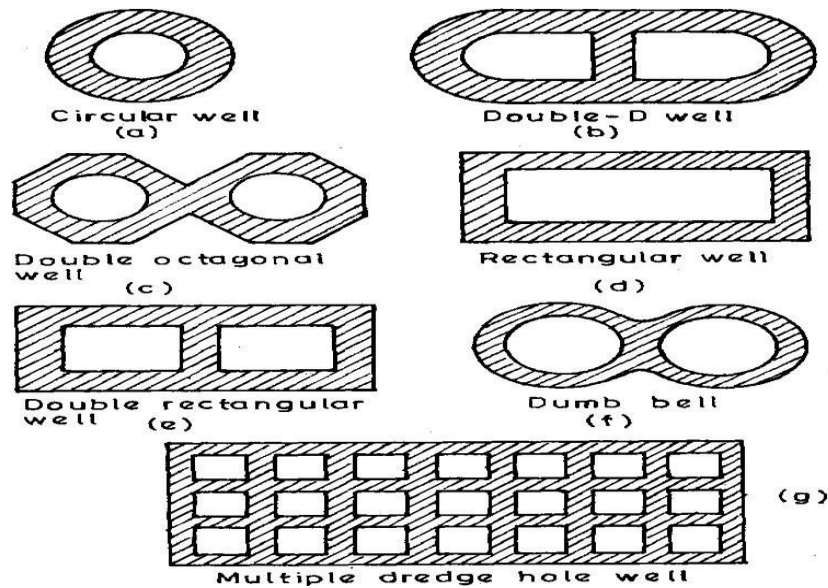

Circular wells: Most common shape of well foundations preferably used everywhere are circular wells. It is featured with very high structural strength and is convenient in sinking; additionally the chances of tilting are exclusively minimum. These circular well foundations are perfectly suitable for piers of the single-line railway bridges and the double-lane road bridges. But for excessively lengthier piers it turns out to be uneconomical. Thus, the maximum diameter of circular well is principally limited to 9m.

Double-D wells: These wells are usually employed on the piers and abutments of the bridges that are excessively long to be accommodated on a circular well of 9m diameter. These wells can be sunk easily. But considerable bending moments are introduced in the steining because of difference in pressure between outside and inside of the well. Additionally the square corners at the partition well provide maximum resistance to sinking.

Double-octagonal wells: These wells are considered to be better than Double-D wells in numerous aspects. Most preferably the square corners are eliminated such that bending stresses are reduced considerably. Additionally these wells provide higher resistance against sinking than double-D wells because of increased area.

Twin- circular wells: Two circular identical wells are sunk very close to one another such that they are held with a common well-cap. These wells are sunk simultaneously, adjacently. These wells are preferable where the length of pier cannot be accommodated on a double-D or double-octagonal well. These wells are found advantages where the depth of sinking is smaller and the soil strata bearing capacity is greater.

Rectangular wells: Rectangular wells are principally employed on bridge foundations with depths up to 7m-8m. In case of larger foundations double-rectangular wells can be used. The loading stresses at the steining are very high in rectangular wells.

Components of Well Foundation

The various components of well foundations are

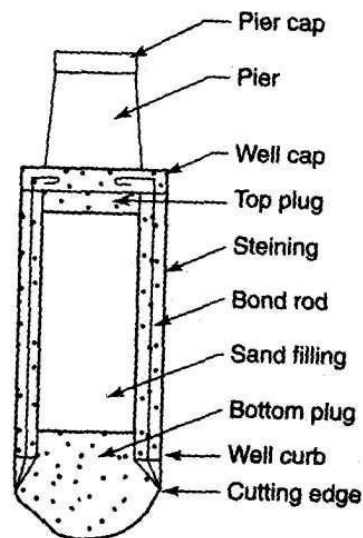

1. Cutting Edge
2. Well Curb
3. Bottom Plug
4. Steining
5. Top Plug
6. Well Cap

Steining: Walls of the wells are known as **steining**. Made of brick masonry, stone masonry, plain or reinforced concrete. The design of steining reinforcement rely on skin friction & unit weight of well. The thickness of steining is designed in such a manner that all platforms of well are sunk under its own weight.

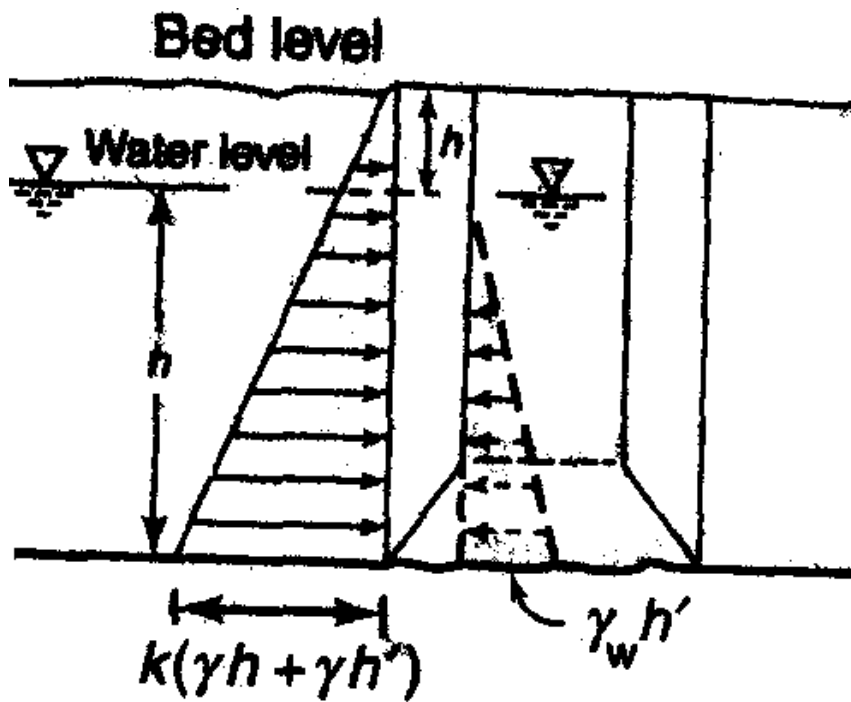

Pressure distribution on steining

Curb: The curb of a well transfers all the superimposed loads to the soil through the cutting edge while sinking. The material used for curbs may be timber or RCC. The forces acting on well curb are shown in fig. The total horizontal force on the well curb on both sides is

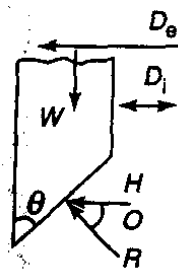

D_e – external diameter
 D_i – internal diameter

Force acting on curb

Sand Filling

The bottom plug concrete is cured and after curing, the well is filled with sand in saturated condition. Sand filling provides

1. Stability to the bottom of the well.
2. Eliminate base the tensile forces at the

Top Plug

The top plug is provided after the filling is completed. Top plug helps in transferring the load of the pier and superstructure to the steining. The thickness of the top plug is generally kept greater than 50 % of the smaller dimension of the dredge hole. If sand filling is used, the top plug is simply constructed using PCC of 1:2:4 otherwise it is reinforced with steel bars and lean concrete of 1:3:6 is used.

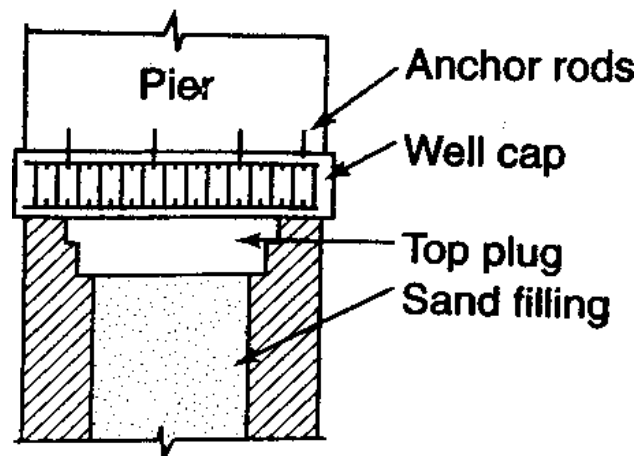

Well Cap: Well cap is constructed as a slab resting on the well it is used to transfer the load of pier to the well As the shape of the well pier and cap are different the well cap forms an interim layer to accommodate the pier. The well cap is so designed that the base of the pier is provided with a minimum all round offset. The centre of the well cap is made to coincide with that of the pier and not with that of the well. Such positioning nullifies the effect of the minor shifts which might have occurred during well sinking.

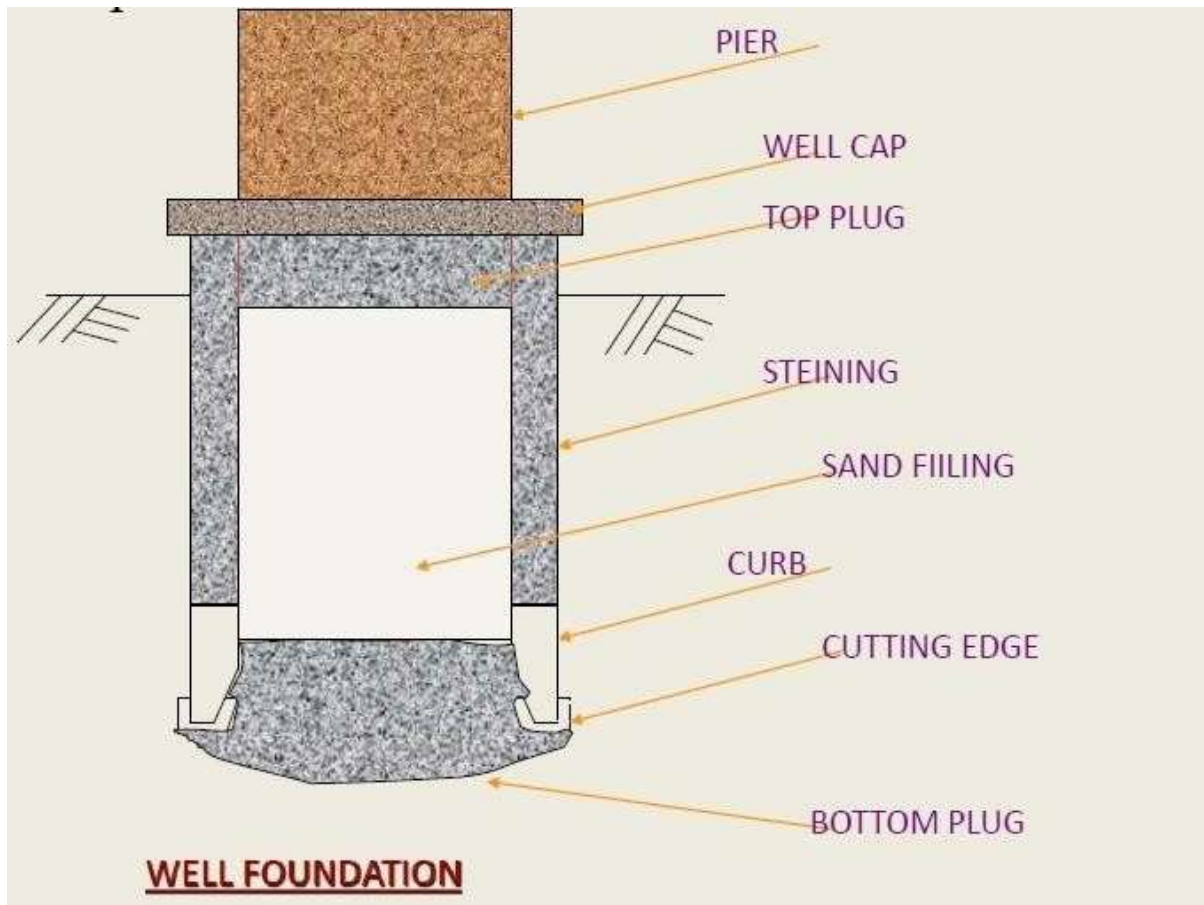

Forces acting on well foundation

Dead loads: It includes weight of superstructure (pier/abutment) + self weight of well.

Live loads: Load caused due to tractive effect of vehicles on bridges and road, load due to human beings, furniture floors & other materials. For road bridges, the live loads may be specified via standard specifications and code of practice for road bridges.

Impact loads: The impact loads is the result of live load and shall be considered only during the design of a pier cap and the bridge seat on the abutment. However, for other components of the well this effect shall be neglected.

Wind loads: The wind loads shall be seen only on the exposed area in elevation and hence acts laterally on the bridge. According to IS Code: 875 provision the wind on super structures, sub structure, live load situated above the water level is calculated.

Water pressure: The water pressure due to water current is acted on the portions of substructure that lies between the water level and the maximum scour level. In case of piers lying parallel to the direction of water, the intensity of water shall be determined by,

$$P = KV^2$$

P = intensity of pressure (KN/m²),

K = constant (that depend upon the shape of well)

Maximum value i.e. = 0.788 for square ended piers

Minimum value i.e. = 0.237 for piers having cut and ease/clam water

V = Velocity of current/water flow (m/s)

An assumption is made that V₂ is maximum at free surface of water and zero at the deepest scour level. The velocity at surface is assumed to be $\sqrt{2}$ times the average velocity.

$$\text{Surface velocity} = \sqrt{2} * \text{average velocity}$$

Longitudinal forces: Longitudinal forces results from tractive and braking forces. The longitudinal forces depend on the type of vehicles and bearing. These forces get transferred/transmitted into the substructure via fixed bearings and friction in movable bearings.

Earth pressure: The Rankines's theory and Coulombs theory is utilized to calculate the earth pressure.

Seismic forces: seismic forces are vital when the wells are constructed in seismic zones. The seismic forces act on every members of the superstructure.

$$\text{seismic forces} = \alpha w$$

w= weight of component and

α =seismic coefficient which depends upon the type of seismic zone and its value shall extracted from code. Usually taken between **0.01-0.08**.

Procedure for Sinking of Well foundations

Laying of Curbs

In dry ground excavate up to 15 cm in river bed and place the cutting edge at the required position. If the curb is to be laid under water and depth of water is greater than 5 m, prepare Sand Island and lay the curb. If depth of water exceeds 5 m built curb in dry ground and float it to the site.

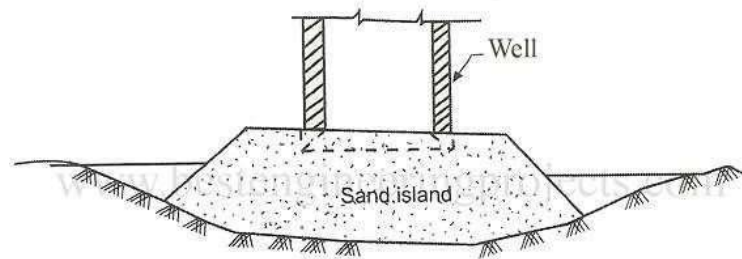

Fig 1 A Typical Sand Island

Construction of Well Steining: The steining should be built in short height of 1.5 m initially and 3 m after a 6 m grip length is achieved. The verticality should be maintained. The aim of the well sinking is to sink the well vertically and at the correct position.

Precautions – The following precautions should be taken during well sinking.

- Outer surface should be regular and smooth.
- Radius of the curb should be 2 to 4 cm larger than the radius of the steining.
- Cutting edge should be of uniform thickness and sharpness.

Sinking Operation

- Excavate material under the inside of well curb mechanically or manually
- Allow the well to remain vertical.
- Up to a depth of 1 m, excavation underwater can be made manually. When the depth of water exceeds 1 m excavate by Jhams or grabs.
- When well goes on sinking skin friction increases and weight of well decreased due to buoyancy.
- When the well does not sink, sunk by applying kentledge. If this operation is not sufficient jet outside the well or grease the outside. A typical loading on steining by kentledge.
- Go on adding sections of steining (2 to 5 m in length) up to the required founding strata.

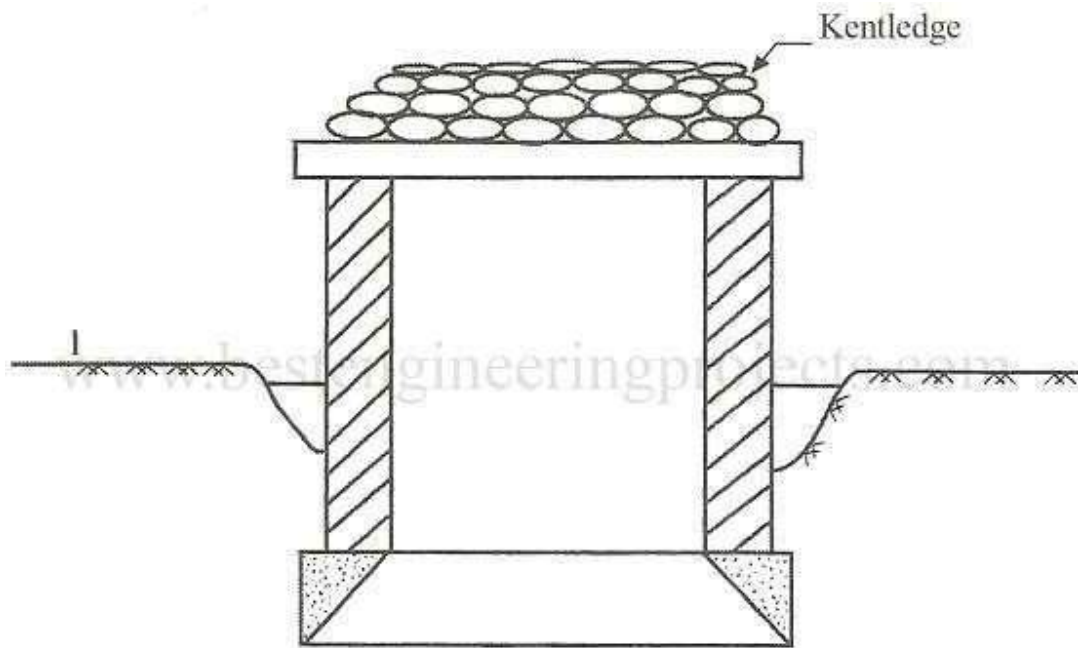

Fig 2 Loading Steining by Kentledge

Tilt and Shift: The well should be sunk vertical & at the right position through all kinds of soils IS 3955 – 1967 suggests that tilt should be restricted to 1 in 60.

Shift: IS 3955 – 1967 suggests that shift be limited to 1% of depth sunk