



**INSTITUTE OF AERONAUTICAL ENGINEERING**  
(Autonomous)

Dundigal, Hyderabad -500 043

**LAB MANUAL**

**CONCRETE TECHNOLOGY AND HIGHWAY  
MATERIALS LABORATORY**

**ACADEMIC YEAR**

**2018 – 2019**

---

**CIVIL ENGINEERING**



# **INSTITUTE OF AERONAUTICAL ENGINEERING**

(Autonomous)

Dundigal, Hyderabad - 500 043

## **DEPARTMENT OF CIVIL ENGINEERING**

**Program: Bachelor of Technology (B. Tech)**

### **VISION OF THE DEPARTMENT**

To produce eminent, competitive and dedicated civil engineers by imparting latest technical skills and ethical values to empower the students to play a key role in the planning and execution of infrastructural & developmental activities of the nation.

### **MISSION OF THE DEPARTMENT**

To provide exceptional education in civil engineering through quality teaching, state-of-the-art facilities and dynamic guidance to produce civil engineering graduates, who are professionally excellent to face complex technical challenges with creativity, leadership, ethics and social consciousness.



# INSTITUTE OF AERONAUTICAL ENGINEERING

(Autonomous)

Dundigal, Hyderabad - 500 043

## DEPARTMENT OF CIVIL ENGINEERING

Program: Bachelor of Technology (B. Tech)

| PROGRAM OUTCOMES (PO's) |  |
|-------------------------|--|
| PO1                     | <b>Engineering knowledge:</b> Apply the knowledge of mathematics, science, engineering fundamentals, and an engineering specialization to the solution of complex engineering problems.  |
| PO2                     | <b>Problem analysis:</b> Identify, formulate, review research literature, and analyze complex engineering problems reaching substantiated conclusions using first principles of mathematics, natural sciences, and engineering sciences.   |
| PO3                     | <b>Design/development of solutions:</b> Design solutions for complex engineering problems and design system components or processes that meet the specified needs with appropriate consideration for the public health and safety, and the cultural, societal, and environmental considerations.         |
| PO4                     | <b>Conduct investigations of complex problems:</b><br>Use research-based knowledge and research methods including design of experiments, analysis and interpretation of data, and synthesis of the information to provide valid conclusions.   |
| PO5                     | <b>Modern tool usage:</b> Create, select, and apply appropriate techniques, resources, and modern engineering and IT tools including prediction and modeling to complex engineering activities with an understanding of the limitations.   |
| PO6                     | <b>The engineer and society:</b> Apply reasoning informed by the contextual knowledge to assess societal, health, safety, legal and cultural issues and the consequent responsibilities relevant to the professional engineering practice.   |
| PO7                     | <b>Environment and sustainability:</b> Understand the impact of the professional engineering solutions in societal and environmental contexts, and demonstrate the knowledge of, and need for sustainable development.   |
| PO8                     | <b>Ethics:</b> Apply ethical principles and commit to professional ethics and responsibilities and norms of the engineering practice.  |
| PO9                     | <b>Individual and team work:</b> Function effectively as an individual, and as a member or leader in diverse teams, and in multidisciplinary settings.   |
| PO10                    | <b>Communication:</b> Communicate effectively on complex engineering activities with the engineering community and with society at large, such as, being able to comprehend and write effective reports and design documentation, make effective presentations, and give and receive clear instructions. |
| PO11                    | <b>Project management and finance:</b> Demonstrate knowledge and understanding of the engineering and management principles and apply these to one's own work, as a member and leader in a team, to manage projects and in multidisciplinary environments.   |
| PO12                    | <b>Life-long learning:</b> Recognize the need for, and have the preparation and ability to engage in independent and life-long learning in the broadest context of technological change.   |



# INSTITUTE OF AERONAUTICAL ENGINEERING

(Autonomous)

Dundigal, Hyderabad - 500 043

## DEPARTMENT OF CIVIL ENGINEERING

### Program: Bachelor of Technology (B. Tech)

The Program Specific outcomes (PSO's) listed below were developed specifically to meet the Program Educational Objectives (PEO's). The focus of these PSO's is consistent with the set of required PO's identified in the NBA accreditation guidelines.

The Civil Engineering PSO's require that graduates receiving a Bachelor of Technology in Civil Engineering degree from IARE demonstrate the following.

| PROGRAM SPECIFIC OUTCOMES (PSO's) |   |
|-----------------------------------|---|
| <b>PSO1</b>                       | <b>ENGINEERING KNOWLED:</b> Graduates shall demonstrate sound knowledge in analysis, design, laboratory investigations and construction aspects of civil engineering infrastructure, along with good foundation in mathematics, basic sciences and technical communication .                      |
| <b>PSO2</b>                       | <b>BROADNESS AND DIVERSITY:</b> Graduates will have a broad understanding of economic, environmental, societal, health and safety factors involved in infrastructural development, and shall demonstrate ability to function within multidisciplinary teams with competence in modern tool usage. |
| <b>PSO3</b>                       | <b>SELF-LEARNING AND SERVICE:</b> Graduates will be motivated for continuous self-learning in engineering practice and/or pursue research in advanced areas of civil engineering in order to offer engineering services to the society, ethically and responsibly.                                |

## CONCRETE & HIGHWAY MATERIAL LAB SYLLABUS

| Exp. No. | List of Experiments                                   |
|----------|---|
| 1.       | Aggregate Crushing Strength Test                      |
| 2.       | Aggregate Impact Test                                 |
| 3.       | Specific Gravity And Water Absorption Test            |
| 4.       | Attrition Test of Coarse Aggregates                   |
| 5.       | Abrasion Test of Coarse Aggregates                    |
| 6.       | Shape tests of Coarse Aggregates                      |
| 7.       | Penetration Test of Bituminous Materials              |
| 8.       | Ductility Test of Bituminous Materials                |
| 9.       | Softening Point of Bitumen Materials                  |
| 10.      | Flash and Fire Point Test of Bitumen Materials        |
| 11.      | Normal Consistency of fineness of cement              |
| 12.      | Initial setting time and final setting time of cement |
| 13.      | Compressive Strength of Cement                        |
| 14.      | Specific gravity and soundness of cement              |
| 15.      | Compressive strength of cement                        |
| 16.      | Bulking of sand of cement                             |

## ATTAINMENT OF PROGRAM OUTCOMES (PO's) & PROGRAM SPECIFIC OUTCOMES (PSO's)

| Exp No. | A70195 - Concrete and Highway Materials Lab           | Program outcomes                                | Program specific outcomes |
|---------|---|---|---------------------------|
| 1.      | Aggregate crushing value                              | PO1(H), PO3(M), PO4(H), PO6(L), PO9(S), PO10(L) | PSO1(H), PSO2(M)          |
| 2.      | Aggregate impact test                                 | PO1(H), PO3(M), PO4(H), PO6(L), PO9(S), PO10(L) | PSO1(H), PSO2(M)          |
| 3.      | Specific gravity and water absorption                 | PO1(H), PO3(M), PO4(H), PO6(L), PO9(S), PO10(L) | PSO1(H), PSO2(M)          |
| 4.      | Attrition test  | PO1(H), PO3(M), PO4(H), PO6(L), PO9(S), PO10(L) | PSO1(H), PSO2(M)          |
| 5.      | Abrasion test   | PO1(H), PO3(M), PO4(H), PO6(L), PO9(S), PO10(L) | PSO1(H), PSO2(M)          |
| 6.      | Shape tests   | PO1(H), PO3(M), PO4(H), PO6(L), PO9(S), PO10(L) | PSO1(H), PSO2(M)          |
| 7.      | Penetration test                                      | PO1(H), PO3(M), PO4(H), PO6(L), PO9(S), PO10(L) | PSO1(H), PSO2(M)          |
| 8.      | Ductility test  | PO1(H), PO3(M), PO4(H), PO6(L), PO9(S), PO10(L) | PSO1(H), PSO2(M)          |
| 9.      | Softening point test                                  | PO1(H), PO3(M), PO4(H), PO6(L), PO9(S), PO10(L) | PSO1(H), PSO2(M)          |
| 10.     | Flash and fire point test                             | PO1(H), PO3(M), PO4(H), PO6(L), PO9(S), PO10(L) | PSO1(H), PSO2(M)          |
| 11.     | Normal Consistency of fineness of cement              | PO1(H), PO3(M), PO4(H), PO6(L), PO9(S), PO10(L) | PSO1(H), PSO2(M)          |
| 12.     | Initial setting time and final setting time of cement | PO1(H), PO3(M), PO4(H), PO6(L), PO9(S), PO10(L) | PSO1(H), PSO2(M)          |
| 13.     | Compressive Strength of Cement                        | PO1(H), PO3(M), PO4(H), PO6(L), PO9(S), PO10(L) | PSO1(H), PSO2(M)          |
| 14.     | Specific gravity and soundness of cement              | PO1(H), PO3(M), PO4(H), PO6(L), PO9(S), PO10(L) | PSO1(H), PSO2(M)          |
| 15.     | Compressive strength of cement                        | PO1(H), PO3(M), PO4(H), PO6(L), PO9(S), PO10(L) | PSO1(H), PSO2(M)          |
| 16.     | Bulking of sand of cement                             | PO1(H), PO3(M), PO4(H), PO6(L), PO9(S), PO10(L) | PSO1(H), PSO2(M)          |

## MANDATORY INSTRUCTIONS

1. Students should report to the labs concerned as per the timetable.
2. Record should be updated from time to time and the previous experiment must be signed by the faculty in charge concerned before attending the lab.
3. Students who turn up late to the labs will in no case be permitted to perform the experiment scheduled for the day.
4. After completion of the experiment, certification of the staff in-charge concerned in the observation book is necessary.
5. Students should bring a notebook of about 100 pages and should enter the readings/observations/results into the notebook while performing the experiment.
6. The record of observations along with the detailed experimental procedure of the experiment performed in the immediate previous session should be submitted and certified by the staff member in-charge.
7. Not more than FIVE students in a group are permitted to perform the experiment on a set up.
8. The group-wise division made in the beginning should be adhered to, and no mix up of student among different groups will be permitted later.
9. The components required pertaining to the experiment should be collected from Lab-in-charge after duly filling in the requisition form.
10. When the experiment is completed, students should disconnect the setup made by them, and should return all the components/instruments taken for the purpose.
11. Any damage of the equipment or burnout of components will be viewed seriously either by putting penalty or by dismissing the total group of students from the lab for the semester/year.
12. Students should be present in the labs for the total scheduled duration.
13. Students are expected to prepare thoroughly to perform the experiment before coming to Laboratory.
14. Procedure sheets/data sheets provided to the student's groups should be maintained neatly and are to be returned after the experiment.
15. DRESS CODE:
  - a. Boys - Formal dress with tuck in and shoes.
  - b. Girls - Formal dress (salwar kameez).
  - c. **Apron in blue color for both boys and girls.**
  - d. **Wearing of jeans is strictly prohibited**

## CONTENTS

| <b>S. No</b> | <b>Description</b>   | <b>Page No.</b> |
|--------------|--|-----------------|
| 1.           | <b>Vision &amp; Mission of department</b>  | <b>1</b>        |
| 2.           | <b>Program Outcomes (PO's)</b>   | <b>2</b>        |
| 3.           | <b>Program Specific Outcomes (PSO's)</b>   | <b>4</b>        |
| 4.           | <b>Syllabus</b>  | <b>5</b>        |
| 5.           | <b>Attainment of program outcomes (po's) &amp; program specific outcomes (pso's)</b> | <b>6</b>        |
| 6.           | <b>Mandatory Instructions</b>  | <b>7</b>        |
| 7.           | <b>Contents</b>  | <b>9</b>        |
| 8.           | <b>Experiment No. 1: Aggregate Crushing Strength Test</b>                            | <b>10</b>       |
| 9.           | <b>Experiment No. 2: Aggregate Impact Test</b>                                       | <b>12</b>       |
| 10.          | <b>Experiment No. 3: Specific Gravity and Water Absorption Test</b>                  | <b>16</b>       |
| 11.          | <b>Experiment No. 4: Attrition Test of Coarse Aggregates</b>                         | <b>18</b>       |
| 12.          | <b>Experiment No. 5: Abrasion Test of Coarse Aggregates</b>                          | <b>21</b>       |
| 13.          | <b>Experiment No. 6: Shape tests of Coarse Aggregates</b>                            | <b>25</b>       |
| 14.          | <b>Experiment No. 7: Penetration Test of Bituminous Materials</b>                    | <b>32</b>       |
| 15.          | <b>Experiment No. 8: Ductility Test of Bituminous Materials</b>                      | <b>35</b>       |
| 16.          | <b>Experiment No. 9: Softening Point of Bitumen Materials</b>                        | <b>38</b>       |
| 17.          | <b>Experiment No. 10: Flash and Fire Point Test of Bitumen Materials</b>             | <b>41</b>       |
| 18.          | <b>Experiment No. 11: Normal Consistency of fineness of cement</b>                   | <b>45</b>       |
| 19.          | <b>Experiment No. 12: Initial setting time and final setting time of cement</b>      | <b>46</b>       |
| 20.          | <b>Experiment No. 13: Specific gravity and soundness of cement</b>                   | <b>49</b>       |
| 21.          | <b>Experiment No. 14: Compressive strength of cement</b>                             | <b>51</b>       |
| 22.          | <b>Experiment No. 15: Compressive strength of cement</b>                             | <b>54</b>       |
| 23.          | <b>Experiment No. 16: Bulking of sand of cement</b>                                  | <b>59</b>       |



# EXPERIMENT NO: 01

## AGGREGATE CRUSHING STRENGTH TEST

### Theory and Scope:

This is one of the major Mechanical properties required in a road stone. The test evaluates the ability of the Aggregates used in road construction to withstand the stresses induced by moving vehicles in the form of crushing. With this the aggregates should also provide sufficient resistance to crushing under the roller during construction and under rigid tyre rims of heavily loaded animal drawn vehicles.

The crushing strength or aggregate crushing value of a given road aggregate is found out as per IS-2386 Part- 4.

The aggregate crushing value provides a relative measure of resistance to crushing under a gradually applied compressive load. To achieve a high quality of pavement aggregate possessing low aggregate crushing value should be preferred.

The aggregate crushing value of the coarse aggregates used for cement concrete pavement at surface should not exceed 30% and aggregates used for concrete other than for wearing surfaces, shall not exceed 45% as specified by Indian Standard (IS) and Indian Road Congress (IRC).

### Aim:

To determine crushing strength of a given aggregate as per IS: 2386 part - IV

### Apparatus:

- A steel cylinder of internal diameter 15.2 cm (Steel cylinder with open ends)
- A square base plate, plunger having a piston diameter of 15 cm.
- A cylindrical measure of internal diameter of 11.5 and height 18 cms.
- Steel tamping rod having diameter of 1.6 cms length 45 to 60 cms.
- Balance of capacity 3 kg with accuracy up to 1 gm.
- Compression testing machine capable of applying load of 40 tonnes at a loading rate tonnes per minute

### Procedure:

- The aggregate in surface-dry condition before testing and passing 12.5 mm sieve and retained on 10 mm sieve is selected.
- The cylindrical measure is filled by the test sample of the aggregate in three layers of

approximately equal depth, each layer being tamped 25 times by the rounded end of the tamping rod.

- After the third layer is tamped, the aggregates at the top of the cylindrical measure are leveled off by using the tamping rod as a straight edge. Then the test sample is weighed. Let that be  $w_1$  gm.
- Then the cylinder of test apparatus is kept on the base plate and one third of the sample from cylindrical measure is transferred into cylinder and tamped 25 times by rounded end of the tamping rod.
- Similarly aggregate in three layers of approximately equal depth, each layer being tamped 25 times by rounded end of the tamping rod.
- Then the cylinder with test sample and plunger in position is placed on compression testing machine.
- Load is then applied through the plunger at a uniform rate of 4 tonnes per minute until the total load is 40 tonnes and the load is released.
- Aggregates including the crushed position are removed from the cylinder and sieved on a 2.36mm IS Sieve and material which passes this sieve is collected and weighed. Let this be  $w_2$  gm.
- The above step is repeated with second sample of the same aggregate. The two tests are made for the same specimen for taking an average value.
- Total weight of dry sample taken is  $w_1$ gm. weight of the portion of crushed material passing 2.36mm IS sieve be  $w_2$  gm.

Then the aggregate crushing value is defined as the ratio of weight of fines passing the specified IS sieve to the total weight of the sample ( $w_1$ ).

Aggregate crushing value =  $100 \cdot w_2 / w_1 \%$

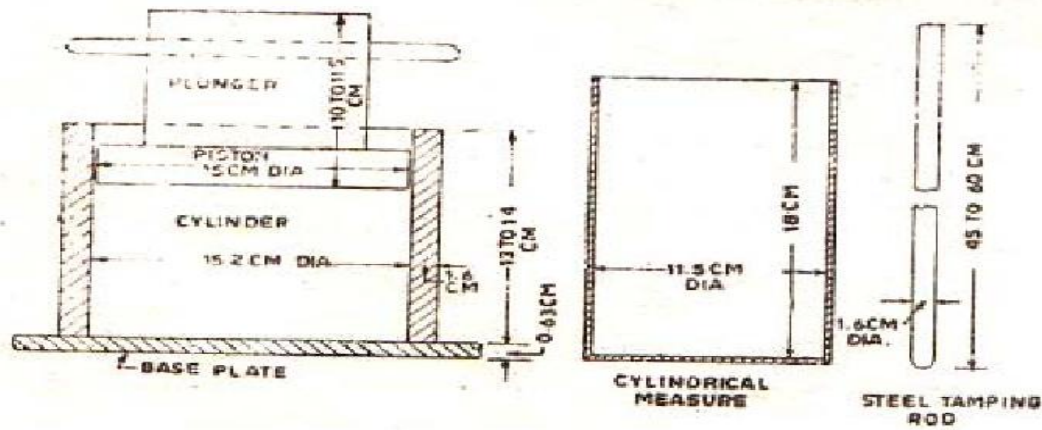

### Aggregate Crushing Test Apparatus

#### Observation and Calculation:

| Trials | Total Weight of dry aggregate sample 10 gm | Weight of fines passing 2.36mm IS sieve, w <sub>2</sub> gm | Aggregate crushing value % | Average aggregate crushing strength value |
|--------|--|--|----------------------------|---|
| 1      |  |  |                            |   |
| 2      |  |  |                            |   |

**Aggregate crushing value =  $100 * w_2 / w_1$ .**

#### **Result:**

The mean (average) of the crushing value aggregate is \_\_\_\_\_ %

#### **Viva voce:**

1. What do you understand by the term "Ten percent Fines value"?
2. Define aggregate crushing value and how crushing strength test is carried out on cylindrical stone specimen explain.
3. What is the use or application of the aggregate crushing test?

#### **Reference:**

1. Indian Standard Methods of Test for Aggregate for concrete IS: 2386 Part-IV, Indian Standards Institution.
2. Indian Standard Specifications for Course and Fine Aggregate from Natural Sources for Concrete, IS: 383 Indian Standards Institution.
3. S.K. Khanna, C.E.G. Justo, Highway Material Testing Laboratory Manual, NemChand & Bros., Roorkee.

## EXPERIMENT NO: 02

### AGGREGATE IMPACT TEST

#### Theory and Scope:

Toughness is the property of a material to resist impact. Due to moving loads, the aggregates are subjected to pounding action or impact and there is possibility of stones breaking into smaller pieces. Therefore, a test designed to evaluate the toughness of stones i.e., the resistance of the stones to fracture under repeated impacts may be called Impact test on aggregates. The test can also be carried on cylindrical stone specimen known as Page Impact test. The aggregate Impact test has been standardized by Indian Standard Institution. The aggregate impact test is conducted as per **IS-2386 Part IV**.

The aggregate Impact value indicates a relative measure of the resistance of aggregate to a sudden shock or an Impact, which in some aggregates differs from its resistance to a slope compressive load in crushing test. A modified Impact test is also often carried out in the case of soft aggregates to find the wet Impact value after soaking the test sample.

Various agencies have specified the maximum permissible aggregate Impact values for the different types of pavements. IRC has specified the following values.

The maximum allowable aggregate Impact value for water bound Macadam; Sub-Base coarse 50% where as cement concrete used in base course is 45%. WBM base course with Bitumen surface in should be 40%. Bituminous Macadam base course should have A.I.V of 35%. All the surface courses should possess an A.I.V below 30%.

**Aim:** To determine the aggregate impact value of given aggregate as per I.S-2386 Part IV.

#### Apparatus:

The apparatus consists of an

- Impact testing machine: The machine consists of a metal base. A detachable cylindrical steel cup of internal diameter 10.2cm and depth 5cm. A metal hammer of weight between 13.5 to 14Kg, 10cm in diameter and 5cm long. An arrangement for raising the hammer and allow it to fall freely between vertical guides from a height of 38cm on the test sample in the cup.
- A cylindrical metal measure having 7.5cm and depth of 5cm for measuring aggregates.
- A tamping rod of circular cross section, 1cm in diameter and 23cm long, rounded at one

end.

- I.S. sieve of sizes 12.5mm, 10mm and 2.36mm.
- Balance of capacity not less than 500gm to weigh accurate up to 0.01gm.

**Procedure:**

- The test sample consists of aggregates passing 12.5mm sieve and retained on 10mm sieve and dried in an oven for 4 hours at a temperature of 100 C to 110 C.
- The aggregates are filled up to about 1/3 full in the cylindrical measure and tamped 25 times with rounded end of the tamping rod.
- The rest of the cylindrical measure is filled by two layers and each layer being tamped 25 times.
- The overflow of aggregates in cylindrical measure is cut off by tamping rod using it has a straight edge.
- Then the entire aggregate sample in a measuring cylinder is weighted nearing to 0.01gm.
- The aggregates from the cylindrical measure are carefully transferred into the cup which is firmly fixed in position on the base plate of machine. Then it is tamped 25 times.
- The hammer is raised until its lower face is 38cm above the upper surface of aggregates in the cup and allowed to fall freely on the aggregates. The test sample is subjected to a total of 15 such blows each being delivered at an interval of not less than one second. The crushed aggregate is then removed from the cup and the whole of it is sieved on 2.36mm sieve until no significant amount passes. The fraction passing the sieve is weighed accurate to 0.1gm. Repeat the above steps with another fresh sample.
- Let the original weight of the oven dry sample be  $w_1$ gm and the weight of fraction passing 2.36mm I.S sieve be  $w_2$ gm. Then aggregate Impact value is expressed as the % of fines formed in terms of the total weight of the sample.

$$\text{Aggregate Impact Value} = 100 * \frac{w_2}{w_1} \%$$

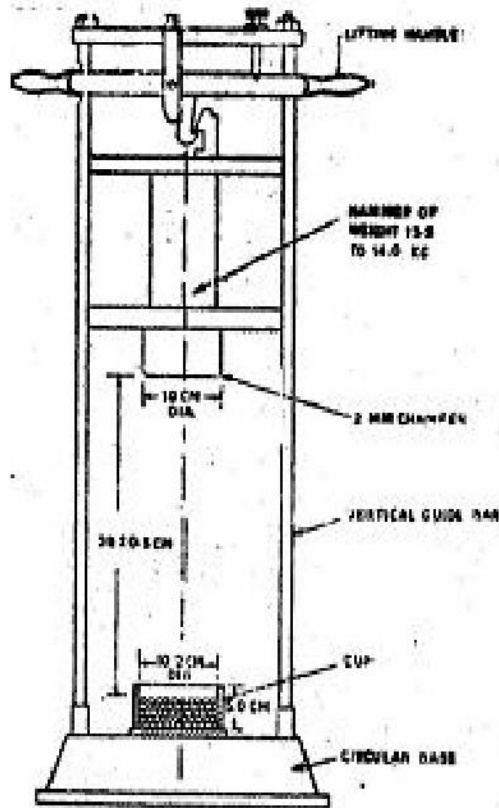

**Aggregate Impact Testing Machine**

**Observation and Calculation:**

| Sl. No. | Details of Sample   | Trail 1 | Trail 2 | Average |
|---------|---|---------|---------|---------|
| 1       | Total Weight of aggregate sample filling the cylinder measure = $W_1$ g |         |         |         |
| 2       | Weight of aggregate passing 2.36 mm sieve after the test = $W_2$ g      |         |         |         |
| 3       | Weight of aggregate retained 2.36 mm sieve after the test = $W_2$ g     |         |         |         |
| 4       | $(W_1 - W_2 + W_2)$   |         |         |         |
| 5       | Aggregate Impact Value = $(W_2/W_1) * 100$ Percent                      |         |         |         |

**Result:**

The mean A.I.V is \_\_\_\_\_ %.

**Viva voce:**

1. How is aggregate Impact expressed?
2. What do you understand by dry and wet Impact value?
3. Aggregate Impact value of material A is 15 and that of B is 35. Which one is better for surface course?

**Reference:**

1. Indian Standard Methods of Test for Aggregate for concrete IS: 2386 Part-IV, Indian Standards Institution.
2. Indian Standard Specifications for Coarse and Fine Aggregate from Natural Sources for Concrete, IS: 383 Indian Standards Institution.
3. S.K. Khanna, C.E.G. Justo, Highway Material Testing Laboratory Manual, Nem Chand & Bros., Roorkee.

## EXPERIMENT NO: 03

### SPECIFIC GRAVITY AND WATER ABSORPTION TEST

**AIM:** To find out the specific gravity and water absorption of the given aggregate

**APPARATUS:**

1. Balance
2. Oven to maintain temp of 100°C to 110°C
3. Wire basket
4. Container with water
5. Trays

**PROCEDURE:**

About 2 Kg of the aggregate sample is washed thoroughly and placed in the wire basket when immersed in distilled water. The basket and the sample are then weighed ( $W_1$ ) while suspended in water at a temp of 22°C to 32°C. The aggregates are then placed on the absorbent clothes and should be cleaned. The surface dry aggregate is then weighed ( $W_2$ ). The aggregate is placed in a shallow tray and kept in an oven maintained at a temp of 110°C for 24 hours. It is then removed from the oven, cooled in an air tight container and weighed ( $W_4$ ).

**OBSERVATIONS:**

|  |                 |
|--|-----------------|
| Weight of saturated aggregate suspended in water with the basket | = $W_1$         |
| Weight of basket above suspended in water                        | = $W_2$         |
| Weight of saturated aggregate in water                           | = $(W_1 - W_2)$ |
| Weight of saturated surface dry aggregate in air                 | = $W_3$         |
| Weight of Water equal to the volume of the aggregate             | = $W_3 - W_5$   |

**CALCULATIONS:**

Specific Gravity= dry weight of aggregate/ weight of equal volume of water =  $\frac{W_4}{W_3 - W_5}$

Water Absorption, % = Percentage by weight of water absorbed in terms of oven dried weight of aggregate

$$= \frac{W_3 - W_4}{W_4} \times 100$$



**INTERFERENCE:**

The specific gravity of aggregates normally used in road construction ranges from about 2.5 to 3.0 with an average value of 2.68. Water absorption value ranges from 0.1 to 2.0 % for aggregates normally used in road surfacing IRC has specified the maximum water absorption values as 10 percent for aggregate used in bituminous surface dressing and built up spray grow.

## **EXPERIMENT NO: 04**

### **ATTRITION TEST**

#### **AIM:**

Determination of the percentage of deleterious material in ice control sands by carrying out the Attrition test.

#### **APPARATUS**

**DRYING OVEN:** A thermostatically controlled drying oven capable of being maintained continuously at a temperature of  $110 \pm 5^{\circ}\text{C}$ .

**BALANCE:** Sensitive to 0.1 g and having a capacity of 1000 g.

**SIEVE:** 75  $\mu\text{m}$ .

**CONTAINERS:** Suitable for drying test samples.

**ATTRITION MACHINE:** Conforming in all its essential characteristics to the design shown. The machine shall consist of a vertical shaft with paddles attached at one end. The other end shall be attached to an electric motor capable of rotating the shaft at a speed of  $390 \pm 10\text{rpm}$  under load.

#### **TEST SAMPLE**

Samples for attrition are to be obtained from materials to be tested by use of a sample splitter or the method of quartering. The test sample shall be the end result of the sampling method and, when dry, should weigh between 490 and 520 g. Under no circumstances should an attempt be made to select samples of an exact predetermined mass.

#### **PROCEDURE**

- Ovens dry the test sample to constant mass. Weigh to the nearest 0.1 g and record the mass as the original mass.
- Set the Attrition test sample tank so that there is a clearance of 5 mm between the bottom of the attrition shaft and the bottom of the tank.
- Place the test sample in the tank and add 175 ml of water and cover with the lid. Run the attrition machine at 390 rpm for 10 min

- Lower the tank, wash the material on the lid and paddles into the tank with a wash bottle and wash the sample onto a 75 µm sieve
- Wash the sample over the 75 µm sieve as described in MTO Test Method LS-602 and oven-dry the material retained to constant mass
- Weigh the oven-dry sample to the nearest 0.1 g

### **CALCULATION**

Calculate the percentage of deleterious material (loss by attrition and washing) as follows

$$A = \frac{\text{mass of pass 75 } \mu\text{m sieve}}{\text{Mass of original sample}} \times 100 = \frac{W_1 - W_2}{W_1} \times 100$$

Where: A = loss by attrition and washing, percent

W<sub>1</sub> = original mass of sample, g

W<sub>2</sub> = mass of retained 75 µm sieve after washing, g

### **REPORTING OF RESULTS**

Report the percentage of deleterious material to the nearest 0.1 percent

### **GENERAL NOTES**

- Care should be taken to ensure that there is no loss of material or water by splashing in the Attrition machine and that all material is washed from the attrition paddles into the sample tank.
- Tap water at room temperature may be used in the test. It is important that exactly 175 ml of water is used since smaller or greater values may have a significant effect on the test result.
- This test includes the pass 75 µm material in the original sample as deleterious material.
- Since a 500 g sample is used, the washing procedure after test may not remove all the pass 75 µm material from very fine sands. If this is suspected, the oven dry sample, after test, should be re-sieved. Any additional pass 75 µm material should be discarded, and the oven dry sample mass (retained) used for calculation purposes. A note should be made on the data card.

### **PRECISION**

Two test results on a sample of sand should not have a difference of greater than one percent. If a greater difference than one percent is obtained, the sample should be re-tested

**ATTRITION TEST**

| <b>Lab No.</b> | <b>ORIGINAL<br/>MASS g</b> | <b>MASS AFTER<br/>TEST g</b> | <b>LOGG g</b> | <b>PERCENT<br/>LOSS</b> |
|----------------|----------------------------|------------------------------|---------------|-------------------------|
|                |                            |                              |               |                         |
|                |                            |                              |               |                         |
|                |                            |                              |               |                         |
|                |                            |                              |               |                         |
|                |                            |                              |               |                         |
|                |                            |                              |               |                         |
| <b>Date :</b>  |                            | <b>Operator :</b>            |               |                         |
| <b>Remarks</b> |                            |                              |               |                         |

## EXPERIMENT NO: 05

### ABRASION TEST

#### Theory and Scope:

Abrasion is a measure of resistance to wear or hardness. It is an essentially property for road aggregates especially when used in wearing coarse. Due to the movements of traffic, the road stones used in the surfacing course are subjected to wearing actions at the top. When traffic moves on the road the soil particle (sand) which comes between the wheel and road surface causes abrasion on the road stone. The abrasion test on aggregate is found as per **I.S.-2386 part-IV**.

Abrasion tests on aggregates are generally carried out by any one of the following methods-

1. Los Angeles abrasion test.
2. Deval abrasion test.
3. Dorry abrasion test.

**Los Angeles Abrasion Test:** - The principle of Los Angeles abrasion test is to find the percentage wear due to the relative rubbing action between the aggregates and steel balls used as abrasive charge. Pounding action of these balls also exist while conducting the test. Maximum Allowable Los Angeles Abrasion Values of Aggregates in Different

types of pavement layers as per Indian Road Congress (IRC) are:-

For sub-base course a value of 60%. For base course such as WBM, Bituminous Macadam (B.M.), Built - Up spray grout base course and etc. value of 50%.

For surface course such as WBM, BM, Bituminous Penetration Macadam, Built-Up spray grout binder course and etc. a value of 40%.

If aggregates are used in surface course as Bituminous carpet, Bituminous surface dressing, single or two coats, cement concrete surface coarse and etc. a value of 35%.

If aggregates are used for bituminous concrete, Cement concrete pavement as surface coarse than aggregate abrasion value of 30% maximum.

**Aim:** To determine the abrasion value of given aggregate sample by conducting Los Angeles abrasion Test.

**Apparatus:**

- Los Angeles machine with inside diameter 70cm and inside length of 50%. Abrasive charges.
- I.S Sieve with 1.7mm opening.
- Weighting Balance of 0.1gm accuracy.

**Procedure:**

- Clean and dry aggregate sample confirming to one of the grading A to G is used for the test. (Refer table no. 1)
- Aggregates weighing 5Kg for grading A, B, C or D and 10Kg for gradings E, F or G may be taken as test specimen and placed in the cylinder.
- The abrasive charge is also chosen in accordance with table no.1 and placed in the cylinder of the machine, and cover is fixed to make dust tight. The machine is rotated at a speed of 30 to 33 revolutions per minute.
- The machine is rotated for 500 revolutions for gradings A, B, C and D, for gradings E, F and G, it shall be rotated for 1000 revolutions.
- After the desired number of revolutions, the machine is stopped and the material is discharged from the machine taking care to take out entire stone dust.
- Using a sieve of size larger than 1.70mm I.S sieve, the material is first separated into two parts and the finer portion is taken out and sieved further on a 1.7mm I.S sieve.
- Let the original weight of aggregate be  $w_1$  gm, weight of aggregate retained on 1.70mm I.S sieve after the test be  $w_2$  gm.

$$\text{Los Angeles abrasion value \%} = \frac{w_1 - w_2}{w_1} \times 100.$$

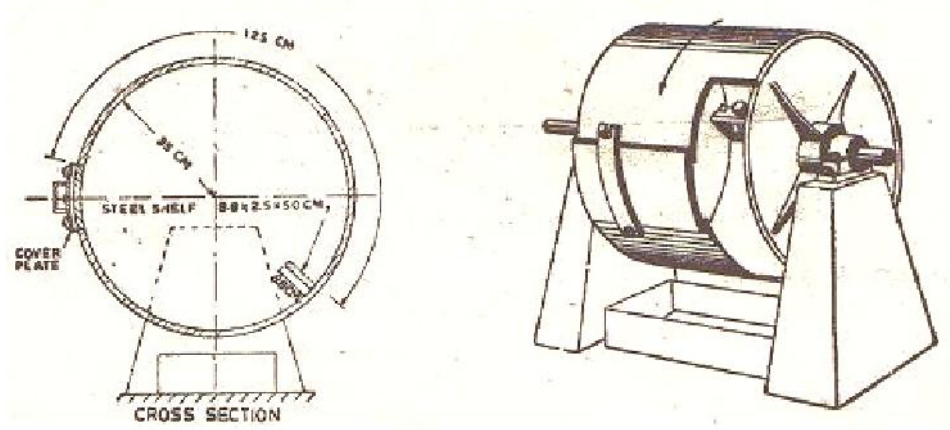

**Schematic Diagram of Los Angeles Abrasion Testing Machine**



**Los Angeles Abrasion Testing Machine**

**Observation and Calculation:**

| Sl No. | Details of Sample  | Trail 1 | Trail 2 | Average |
|--------|--|---------|---------|---------|
| 1      | Weight of Specimen = $W_1$ g   |         |         |         |
| 2      | Weight of Specimen after abrasion test, coarser than 1.70mm IS sieve = $W_2$ g |         |         |         |
| 3      | Percentage wear = $((W_1 - W_2)/W_1) * 100$                                    |         |         |         |

**Table**

| Grading  | Weight in grams of each test sample in the size range, mm<br>(Passing and retained on Square holes) |       |       |       |       |         |         |        |          |           | Abrasive Charge |                    |
|----------|---|-------|-------|-------|-------|---------|---------|--------|----------|-----------|-----------------|--------------------|
|          | 80-63   | 63-50 | 50-40 | 40-25 | 25-20 | 20-12,5 | 20-5-10 | 10-6.3 | 6.3-4.75 | 4.75-2.36 | No. of Spheres  | Weight of Charge,g |
| <b>A</b> |   |       |       | 1250  | 1250  | 1250    | 1250    |        |          |           | 12              | 5000+25            |
| <b>B</b> |   |       |       |       |       | 2500    | 2500    |        |          |           | 11              | 4584+25            |
| <b>C</b> |   |       |       |       |       |         |         | 2500   | 2500     |           | 8               | 3330+20            |
| <b>D</b> |   |       |       |       |       |         |         |        |          | 2500      | 6               | 2500+15            |
| <b>E</b> | 2500  | 2500  | 5000  |       |       |         |         |        |          |           | 12              | 5000+25            |
| <b>F</b> |   |       | 5000  | 5000  |       |         |         |        |          |           | 12              | 5000+25            |
| <b>G</b> |   |       |       | 5000  | 5000  |         |         |        |          |           | 12              | 5000+25            |

**Result:**

The average value of two Los Angeles abrasion test is \_\_\_\_\_%

**Viva voce:**

1. The abrasion value found from Los Angeles test for two aggregates A and B are 50% and 38% respectively. Which aggregate is harder? Why? For what types of constructions are these suitable?
2. Why Los Angeles abrasion test is considered superior to the other form of tests which are used to determine the hardness of aggregates?
3. Two materials have abrasion values 3 and 10 respectively. Which one is harder and why?

**Reference:**

1. Indian Standard Methods of Test for Aggregate for concrete IS: 2386 Part-IV, IndianStandards Institution.
2. Indian Standard Specifications for Coarse and Fine Aggregate from Natural Sources for Concrete, IS: 383 Indian Standards Institution.
3. S.K. Khanna, C.E.G. Justo, Highway Material Testing Laboratory Manual, NemChand& Bros., Roorkee.



## EXPERIMENT NO: 06

### A. SHAPE TEST (*Flakiness Index*)

#### Theory and Scope:

The particle shape of aggregate is determined by the percentages of flaky and elongated particles contained in it. In case of gravel it is determined by its Angularity Number. Flakiness and Elongation tests are conducted on coarse aggregates to assess the shape of aggregates. Aggregates which are flaky or elongated are detrimental to the higher workability and stability of mixes. They are not conducive to good interlocking and hence the mixes with an excess of such particles are difficult to compact to the required degree. For base coarse and construction of bituminous and cement concrete types, the presence of flaky and elongated particles is considered undesirable as they may cause inherent weakness with probabilities of breaking down under heavy loads. Rounded aggregates are preferred in cement concrete road construction as the workability of concrete improves. Angular shape of particles is desirable for granular base coarse due to increased stability derived from the better interlocking when the shape of aggregates deviates more from the spherical shape, as in the case of angular, flaky and elongated aggregates, the void content in an aggregate of any specified size increases and hence the grain size distribution of the graded aggregates has to be suitably altered in order to obtain minimum voids in the dry mix or the highest dry density. It is determined according to the procedure laid down in **IS-2386 (PART- I)**.

**FLAKINESS INDEX:** The flakiness index of aggregates is the percentage by particles whose least dimension (thickness) is less than  $3/5^{\text{th}}$  (0.6) of their mean dimension. The test is not applicable to sizes smaller than 6.3mm.

**ELONGATION INDEX:** The elongation index of an aggregate is the percentage by weight of particles whose greatest dimension (length) is greater than 1 and  $4/5^{\text{th}}$  times (1.8 times) their mean dimensions. The elongation test is not applicable to sizes smaller than 6.3mm.

**ANGULARITY NUMBER:** The angularity number of an aggregate is the amount by which the percentage voids exceeds 33 after being compacted in a prescribed manner. The minimum allowable combined index of aggregates used in surface course of pavement is 30%

**Aim:** - To determine the flakiness Index of a given aggregates sample.





**Flakiness Index Test in Progress**

| SIZE OF AGGREGATE             |                           | THICKNESS GAUGE (0.6 TIMES THE MEAN SIEVE) mm | Weight of the fraction consisting of at least 200 pieces in gm. | Weight of aggregates in each fraction passing thickness gauge, gm |
|-------------------------------|---------------------------|---|---|---|
| PASSING THROUGH I.S. SIEVE mm | RETAINED ON I.S. SIEVE mm |   |   |   |
| 63                            | 50                        | 33.90   |   |   |
| 50                            | 40                        | 27.00   |   |   |
| 40                            | 25                        | 19.50   |   |   |
| 31.5                          | 25                        | 16.95   |   |   |
| 25                            | 20                        | 13.50   |   |   |
| 20                            | 16                        | 10.80   |   |   |
| 16                            | 12.5                      | 8.55  |   |   |
| 12.5                          | 10.0                      | 6.75  |   |   |
| 10                            | 6.3                       | 4.89  |   |   |

**Result:** The flakiness index of the given sample of aggregates is \_\_\_\_\_%.

## B. SHAPE TEST (*Elongation Index*)

**Aim:** To determine the Elongation Index of the given aggregate sample.

**Apparatus:** Length gauge, I.S-sieves as given in the table and a balance of accuracy 0.01 Gm.

### Procedure:

- The sample is sieved through I.S-sieves specified in the table. A minimum of 200 aggregate pieces of each fraction is taken and weighed.
- Each fraction is thus gauged individually for length in a length gauge. The gauge length is used should be those specified in the table for the appropriate material.
- The pieces of aggregates from each fraction tested which could not pass through the specified gauge length with its long side are elongated particles and they are collected separately to find the total weight of aggregate retained on the length gauge from each fraction.
- The total amount of elongated material retained by the length gauge is weighed to an accuracy of at least 0.1% of the weight of the test sample.
- The weight of each fraction of aggregate passing and retained on specified sieves sizes are found -  $W_1, W_2, W_3, \dots$ . And the total weight of sample determined =  $W_1+W_2+W_3+\dots = W g$ . Also, the weights of material from each fraction retained on the specified gauge length are found =  $x_1, x_2, x_3, \dots$  and the total weight retained determined =  $x_1+x_2+x_3+\dots = x gm$ .
- The elongation index is the total weight of the material retained on the various length gauges, expressed as a percentage of the total weight of the sample gauged.

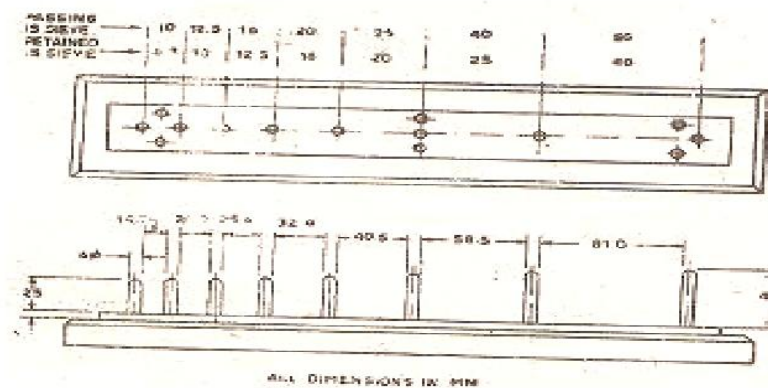

**Length Gauge**



**Elongation Index Test in Progress**

| SIZE OF AGGREGATE            |                          | LENGTH GAUGE (1.8 TIMES THE MEAN SIEVE) mm | Weight of the fraction consisting of atleast 200 pieces in gm. | Weight of aggregates in each fraction passing thickness gauge, gm. |
|------------------------------|--------------------------|--|--|--|
| PASSING THROUGH I.S SIEVE mm | RETAINED ON I.S SIEVE mm |  |  |  |
| 63                           | 50                       |  |  |  |
| 50                           | 40                       | 81.00                                      |  |  |
| 40                           | 25                       | 58.50                                      |  |  |
| 31.5                         | 25                       | -  |  |  |
| 25                           | 20                       | 40.50                                      |  |  |
| 20                           | 16                       | 32.40                                      |  |  |
| 16                           | 12.5                     | 25.60                                      |  |  |
| 12.5                         | 10.0                     | 20.20                                      |  |  |
| 10                           | 6.3                      | 14.70                                      |  |  |

**Result:** The elongation index of a given sample of aggregate is \_\_\_\_\_%.

## C.SHAPE TEST (*Angularity Number*)

**Aim:** To determine the Angularity Number of the given aggregate sample.

### **Apparatus:**

1. The apparatus consists of a metal cylinder closed at one end and of about 3-liter capacity. The diameter and height of this being approximately equal i.e., about 15.64cms diameter and 15.64cms height.
2. A metal tamping rod of circular cross section 1.6cms in diameter and 60cms in length rounded at one end.
3. I.S. sieves of sizes 20, 16.5, 10, 6.3 and 4.75mm and balance of capacity 10kg to weigh upto 0.1gm.

### **Procedure:**

- Metal cylinder is calibrated by determining the weight of water at 27°C required to fill it, so that no meniscus is present above the rim of the container.
- The sample of single size aggregate retained between the specified pair of sieves is dried in an oven at a temperature 100°C to 110°C for 24 hours and cooled prior to testing.
- The aggregates are placed in the cylinder and subjected to 100 blows of the tamping rod at a rate of about 2 blows per second. Each blow is applied by holding the rod vertically with its rounded end 5cms above the surface of the aggregates and releasing it so that it falls vertically and no force is applied to the rod.
- The process of filling and tamping is repeated exactly as described above with a second and third layer of aggregate.
- After the third layer is tamped, the cylinder is filled to overflowing and the aggregates are struck off level with the top using a tamping rod as a straight edge. The aggregate with cylinder is then weighed accurately.
- All the above steps are repeated on another sample and averages of two are represented.
- The angularity number is calculated from the formula,

$$\text{Angularity Number} = 67 \sqrt{\frac{W}{CG}}$$

W = Mean weight of aggregates in the cylinder, gm.

C = Weight of water required in the cylinder, gm. G = Specific gravity of

aggregate.

**Observation and Calculation:**

| Details of Sample  | Trail 1 | Trail 2 | Average |
|--|---------|---------|---------|
| Weight of aggregate Filling the cylinder to the nearest five grams |         |         |         |

**Result:** The angularity number of given aggregate sample = \_\_\_\_\_.

**Viva Voce:**

1. Explain what is meant by flaky and elongated particles?
2. Explain Angularity Number. How is it found?
3. What do you understand by the term Combined Index?

**Reference:**

1. Indian Standard Methods of Test for Aggregate for concrete IS: 2386 Part-I, IndianStandards Institution.
2. Indian Standard Specifications for Coarse and Fine Aggregate from Natural Sources forConcrete, IS: 383 Indian Standards Institution.
3. S.K. Khanna, C.E.G. Justo, Highway Material Testing Laboratory Manual, Nem Chand & Bros., Roorkee.

## **EXPERIMENT NO: 07**

### **PENETRATION TEST OF BITUMINOUS MATERIALS**

#### **Theory and Scope:**

The consistencies of bituminous materials vary depending upon several factors such as constituents, temperature, etc. As temperature ranges between 25° and 50°C most of the paving bitumen grades remain in semi-solid or in plastic states and their viscosity is so high that they do not flow as liquid.

Determination of absolute viscosity of bituminous material is not so simple. Therefore the consistency of these materials is determined by indirect methods. The consistency of bitumen is determined by penetration test which is a very simple test. Various types and grades of bituminous materials are available depending on their origin and refining process. The penetration test determines the consistency of these materials for the purpose of grading them, by measuring the depth (in units of one tenth of a millimeter or one hundredth of a centimeter) to which a standard needle will penetrate vertically under specified conditions of standard load, duration and temperature. Thus the basic principle of the penetration test is the measurement of the penetration (in units of one tenth of a mm) of a standard needle in a bitumen sample maintained at 25°C during five seconds, the total weight of the needle assembly being 100gm. The softer the bitumen, the greater will be the penetration. The test is conducted as per IS-1203 for paving bitumen.

**Aim:** To determine the grade of a given binder.

**Apparatus:** It consists of items like container, needle, water bath, penetrometer, stop watch etc. Container is 55mm in diameter and 35mm to 57mm height. The needle is provided with a shank approximately 3.0mm in diameter into which it is immovably fixed.

#### **Procedure:**

- The bitumen is softened to a paving consistency between 75° and 100°C above the approximate temperature at which bitumen softens.
- The sample material is thoroughly stirred to make it homogeneous and free from air bubbles and water.
- The sample containers are cooled in atmosphere of temperature not lower than 13°C for one hour. Then they are placed in temperature controlled water bath at a temperature of



25°C for a period of one hour.

- The weight of needle, shaft and additional weight are checked. The total weight of this assembly should be 100gm.
- Using the adjusting screw, the needle assembly is lowered and the tip of the needle is made to just touch the top surface of the sample.
- The needle assembly is clamped in this position. The contact of the tip of the needle is checked using the mirror placed on the rear of the needle.
- The initial reading of the penetrometer dial is either adjusted to zero or the initial reading is noted.
- Then the needle is released by pressing a button and a stop watch is started. The needle is released exactly for a period of 5.0secs.
- At least 3 measurements are made on this sample by testing at distance of not less than 100mm apart.
- The difference between the initial and final penetration readings are taken as the penetration value.

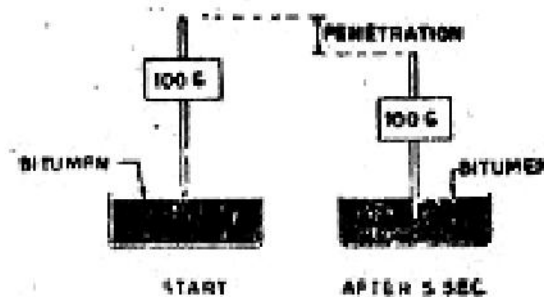

**Penetration Test Concept**



## Penetrometer

### Observation and Calculation:

| Readings                          | Trails |   |   | Mean Value |
|-----------------------------------|--------|---|---|------------|
|                                   | 1      | 2 | 3 |            |
| Penetrometer Dial Initial Reading |        |   |   |            |
| Penetrometer Dial Final Reading   |        |   |   |            |
| Penetration Value                 |        |   |   |            |

### Result:

The average penetration value of a given bitumen sample is \_\_\_\_\_ and the grade of bitumen is \_\_\_\_\_.

### Viva Voce:

1. What are the applications of penetration test?
2. What do you understand by the term 30/40 bitumen?
3. What are the precautions to be taken while conducting a penetration test?

### References:

1. Indian Standard Method for Tar and Bitumen, Determination of Penetration of Bitumen, IS: 1203, Indian Standards Institution.
2. Indian Standard Specification for Paving Bitumen, IS: 73.
3. S.K. Khanna and C.E.G Justo, Highway Materials Testing Laboratory Manual, NemChand Bros. Roorkee.

## **EXPERIMENT NO: 08**

### **DUCTILITY TEST OF BITUMINOUS MATERIALS**

#### **Theory and Scope:**

A certain minimum ductility is necessary for a bitumen binder. This is because of the temperature changes in bituminous mixes and the repeated deformations that occur in flexible pavements due to the traffic loads. It is of significant importance that the binders form ductile thin films around the aggregates. The binder material which does not possess sufficient ductility would crack and thus provide previous pavement surface. This in turn results in damaging effect to the pavement structure. The ductility is expressed as the distance in centimeters to which a standard briquette of bitumen can be stretched before the thread breaks. The test is standardized by the **IS: 1208**. The test is conducted at  $27^{\circ}\pm 0.5^{\circ}\text{C}$  and a rate of pull of  $50\pm 2.5$  mm per minute.

**Aim:** To conduct ductility test on given bitumen sample.

**Apparatus:** Briquette mould, (length - 75mm, distance between clips - 30mm, width at mouth of clips - 20mm, cross section at minimum width - 10mm x 10mm), Ductility machine with water bath and a pulling device at a precalibrated rate, a putty knife, thermometer.

#### **Procedure:**

The bitumen sample is method to a pouring temperature ( $75^{\circ}\text{C}$  to  $100^{\circ}\text{C}$ ) and poured into the mould assembly and placed on a brass plate, where a solution of glycerin or soap solution is applied at all surfaces of briquette mould exposed to bitumen.

After the sample is poured to the mould, thirty to forty minutes the entire assembly is placed in a water bath at  $27^{\circ}\text{C}$ .

Then the sample is removed from the water bath maintained at  $27^{\circ}\text{C}$  and excess bitumen material is cutoff by leveling the surface using hot knife.

After trimming the specimen, the mould assembly containing sample is replaced in water bath maintained at  $27^{\circ}\text{C}$  for 85 to 95 minutes. Then the sides of mould are removed and the clips are carefully booked on the machine without causing any initial strain. Two or more specimens may be prepared in the moulds and clipped to the machine so as to conduct these test simultaneously.

The pointer is set to read zero. The machine is started and the two clips are thus pulled apart horizontally. While the test is in operation, it is checked whether the sample is immersed in water

at depth of atleast 10mm. The distance at which the bitumen thread of each specimen breaks is recorded (in cm) to report as ductility value.

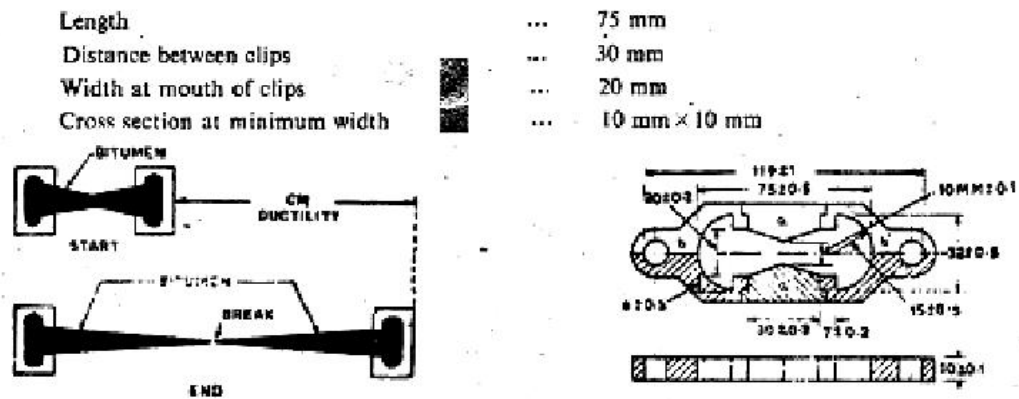

**Ductility Test Concept**

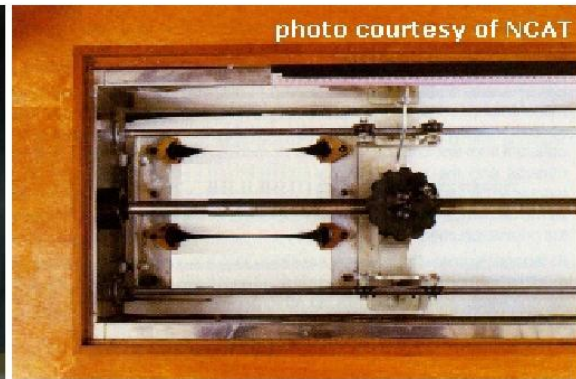

**Sample Prepared in BriquetteMould and Ductility Apparatus**

**Observation and Calculation:**

Table

| Test Property   | Trails |   |   | Mean Value |
|-----------------|--------|---|---|------------|
|                 | 1      | 2 | 3 |            |
| Ductility Value |        |   |   |            |

**Result:** The ductility value of the given bitumen sample is \_\_\_\_\_ cm.

**Viva Voce:**

1. List the factors that affect the result of a ductility test.
2. What do you understand by the term repeatability and reproducibility?
3. Explain the significance of ductility test.

**References:**

1. Indian Standard Method for Tar and Bitumen, Determination of Ductility of Bitumen, IS: 1208, Indian Standards Institution.
2. Indian Standard Specification for Paving Bitumen, IS: 73.
3. S.K. Khanna and C.E.G Justo, Highway Materials Testing Laboratory Manual, NemChand Bros. Roorkee.

**EXPERIMENT NO: 09**  
**SOFTENING POINT OF BITUMINOUS MATERIALS**

**Theory and Scope:**

Bitumen does not suddenly change from solid to liquid state, but as the temperature increase, it gradually becomes soften until it flows readily. The softening point is the temperature at which the substance attains particular degree of softening under specified condition of test. For bitumen it is usually determined by Ring and Ball apparatus. The test is conducted as per **IS: 1205**.

**Aim:**

To determine the softening point of given paving bitumen as per IS: 1205.

**Apparatus:**

Ring and Ball apparatus, Water bath with stirrer, Thermometer, Glycerin, etc. Steel balls each of 9.5mm and weight of  $2.5 \pm 0.08$ gm.

**Procedure:**

- Sample material is heated to a temperature between 75° and 100°C above the approximate softening point until it is completely fluid and is poured in heated rings placed on the metal plate.
- To avoid sticking of the bitumen to metal plate, coating is done to this with a solution of glycerin and dextrin.
- After cooling the rings in air for 30 minutes, the excess bitumen is trimmed and rings are placed in the support.
- At this time the temperature of distilled water is kept at 5°C. This temperature is maintained for 15 minutes after which the balls are placed in position.
- Then the temperature of water is raised at uniform rate of 5°C per minute with a controlled heating unit, until the bitumen softens and touches the bottom plate by sinking of balls. At least two observations are made. For material whose softening point is above 80°C, glycerin is used for heating medium and the starting temperature is 35°C instead of 5°C.
- The temperature at the instant when each of the ball and sample touches the bottom plate of support is recorded as softening point value.

## Softening Test Concept

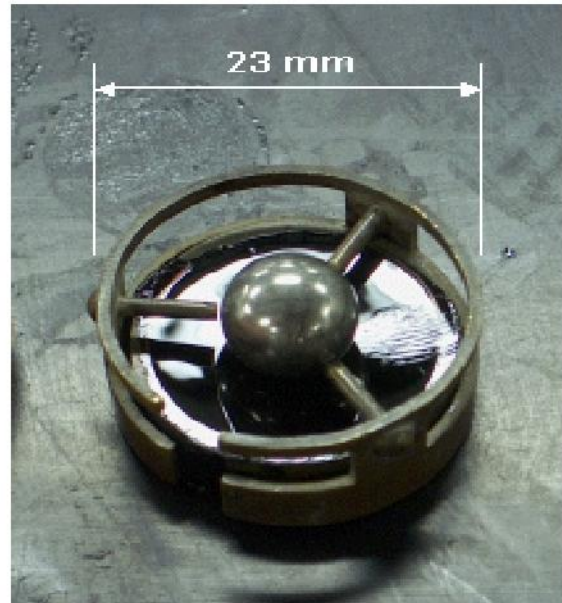
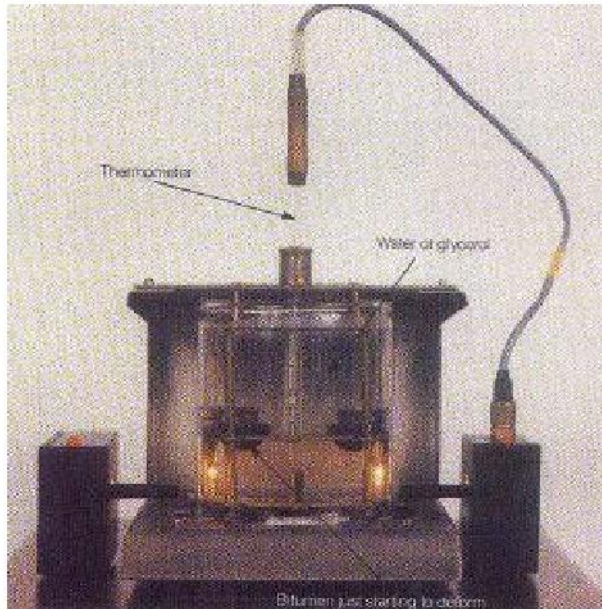

### Softening Point Apparatus and Ring and Ball Guides

#### Observation and Calculation:

| Test Property   | Trails |   |   | Mean Value |
|---|--------|---|---|------------|
|   | 1      | 2 | 3 |            |
| Temperature ( $^{\circ}$ C) at which I ball touches the bottom plate  |        |   |   |            |
| Temperature ( $^{\circ}$ C) at which II ball touches the bottom plate |        |   |   |            |
| <b>Final Softening Point Temperature</b>                              |        |   |   |            |

**Result:** The softening point value of given bitumen sample is \_\_\_\_\_ $^{\circ}$ C and grade of bitumen is \_\_\_\_\_.

#### Viva Voce:

1. What are the factors which affect the ring and ball test results?
2. What is softening point?

If material A has softening point of 56 and B has 42 which binder is good and why?

**References:**

1. Indian Standard Method for Tar and Bitumen, Determination of Softening Point of Bitumen, IS: 1205, Indian Standards Institution.
2. Indian Standard Specification for Paving Bitumen, IS: 73.
3. S.K. Khanna and C.E.G Justo, Highway Materials Testing Laboratory Manual, NemChand Bros. Roorkee.



## **EXPERIMENT NO: 10**

### **FLASH AND FIRE POINT TEST OF BITUMINOUS MATERIALS**

#### **Theory and Scope:**

Flash and Fire point test is a safety test conducted on a bituminous material so that it gives an indication of the critical temperature at and above where precautions should be taken to eliminate fire hazards during its applications. Bituminous materials leave out volatiles at high temperature depending upon their grade. These volatile vapors catch fire causing a flash. This condition is very hazardous and it is therefore essential to qualify this temperature for each bitumen grade, so that the paving engineers may restrict the mixing or application temperature well within the limits. Flash and Fire point test is conducted as per **IS: 1209**.

As per IS: 1209 the definitions of flash and fire point are:

Flash Point: "The flash point of a material is the lowest temperature at which the vapour of substance momentarily takes fire in the form of a flash under specified conditions of test".

Fire Point: "The fire point is the lowest temperature at which the material gets ignited and burns under specified condition of test".

#### **Aim:**

To determine the flash and fire point of a given bituminous material.

#### **Apparatus:**

Pensky-Martens closed cup tester, thermometer, heating source, flame exposure.

#### **Procedure:**

- All parts of the cup are cleaned and dried thoroughly before the test is started.
- The material is filled in the cup upto a mark. The lid is placed to close the cup in a closed system. All accessories including thermometer of the specified range are suitably fixed.
- The bitumen sample is then heated. The test flame is lit and adjusted in such a way that the size of a bed is of 4mm diameter. The heating of sample is done at a rate of 5° to 6°C per minute. During heating the sample the stirring is done at a rate of approximately 60 revolutions per minute.
- The test flame is applied at intervals depending upon the expected flash and fire points And corresponding temperatures at which the material shows the sign of flash and fire are noted.

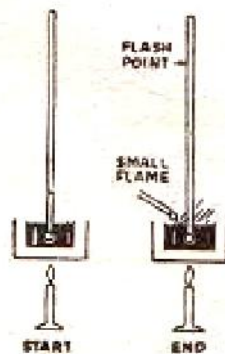

### Flash and Fire Point Test Concept



### Flash and Fire Point Test in Progress

Observation and Calculation:

| Test        | Trials |   |   | Mean Value |
|-------------|--------|---|---|------------|
|             | 1      | 2 | 3 |            |
| Flash Point |        |   |   |            |
| Fire Point  |        |   |   |            |

**Result:** The temperature at which the flame application that causes a bright flash \_\_\_\_\_°C and temperature at which the sample catches fire \_\_\_\_\_°C.

**Viva Voce:**

1. Define flash and fire points.
2. What is the significance of flash and fire point test?
3. What are the parameter that affects the result of flash and fire point tests?

**References:**

1. Indian Standard Method for Tar and Bitumen, Determination of Flash and Fire Point of Bitumen, IS: 1209, Indian Standards Institution.
2. Indian Standard Specification for Paving Bitumen, IS: 73.
3. S.K. Khanna and C.E.G Justo, Highway Materials Testing Laboratory Manual, NemChand Bros. Roorkee.

## EXPERIMENT NO: 11

### NORMAL CONSISTENCY OF FINENESS OF CEMENT

#### Theory and Scope:

Standard consistency of cement paste is defined as that consistency which permits the Vicat plunger to penetrate to a point 5 to 7 mm from the bottom of the Vicat mould in this test. It is expressed as amount of water as a percentage [by weight] of dry cement. Standard consistency is also called normal consistency.

#### Aim:

To determine the percentage of water required for preparing cement paste of standard consistency, used for other tests.

#### Apparatus:

Vicat apparatus with plunger, I.S. Sieve No. 9, measuring jar, weighing balance

#### Procedure:

- The vicat apparatus consists of a D- frame with movable rod. An indicator is attached to the movable rod, which gives the penetration on a vertical scale.
- A plunger of 10 mm diameter, 50 mm long is attached to the movable rod to find out normal consistency of cement.
- Take 300 gm of cement sieved through I.S. Sieve No. 9 and add 30% by weight (90 ml) water to it. Mix water and cement on a non-porous surface thoroughly with in 3 to 4 minutes.
- The cement paste is filled in the vicatmould and top surface is leveled with a trowel. The filled up mould shall be placed along with its bottom non-porous plate on the base plate of the vicat apparatus centrally below the movable rod. The plunger is quickly released into the paste. The settlement of plunger is noted. If the penetration is between 33 mm to 35 mm from top (or) 5 mm to 7 mm from the bottom, the water added is correct. If the penetration is less than required, the process is repeated with different percentages of water till the desired penetration is obtained.

#### Observation and Calculation:

| S.No. | Amuont of water mixed | Penetration of Plunger from top | Remark |
|-------|-----------------------|---------------------------------|--------|
|       |                       |                                 |        |

|  |  |  |  |
|--|--|--|--|
|  |  |  |  |
|--|--|--|--|

**Result:** The normal consistency of cement =

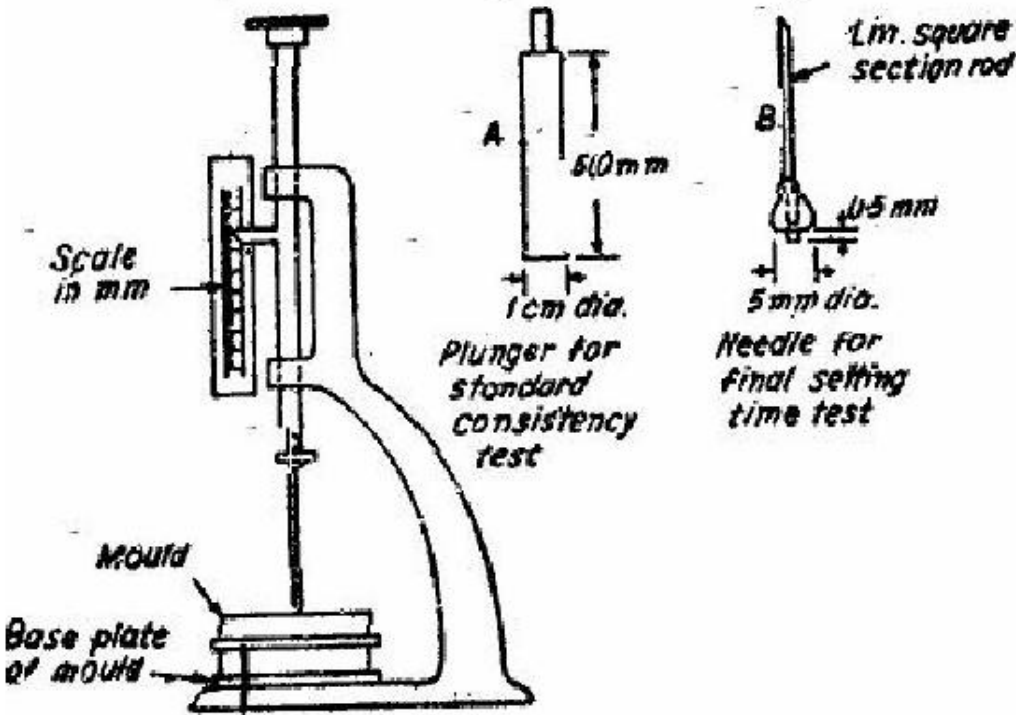

**Vicat Apparatus**

**Viva Voce:**

1. What is normal or standard consistency of a cement paste?
2. What are the factors affecting the result of the test?
3. What do you understand by the term flash setting?

**Reference:**

1. Indian Standard Methods of Physical Tests for cements IS: 4031, Indian Standards Institution.
2. Indian Standard Specifications for ordinary and low heat Portland cement IS: 269, Indian Standards Institution.
3. Neville. A. M, Properties of concrete, 3<sup>rd</sup> edition, Pitman publishing company, 1981.

## **EXPERIMENT NO: 12**

### **INITIAL AND FINAL SETTING TIMES OF CEMENT**

#### **Theory and Scope:**

Setting means becoming finer and harder, changing from some liquid state to plastic state and from plastic state to solid state. Mortar or concrete when mixed is in semi liquid state.

The chemical action between cement and water starts, and the mixture goes into plastic state.

#### **Aim:**

To find initial and final setting times of cement.

#### **Apparatus:**

Vicat apparatus with mould, I.S. sieve No. 9, Initial and final setting time needles, measuring jar, weighing balance, etc.

#### **Procedure:**

##### **Initial setting time:**

- Initial setting time is defined as the time elapsed between the moment that the water is added to the cement, to the time that the paste starts losing its plasticity i.e. the initial setting time needle fails to penetrate the cement paste kept in the mould by about 33-35 mm from the top or 5-7 mm from bottom of the indicator is called initial setting time.
- Take a cement sample weighing 300 gm, sieved through I.S. sieve No. 9 and mixed with percentage of water as determined in normal consistency test. Stopwatch should be started at the instant when water is added to the cement.
- Prepared cement paste is filled in vicats mould and leveled with trowel. This mould filled with cement paste kept on the non porous plate is now placed under the movable rod with initial setting time needle of cross section 1mm x 1mm
- The needle is quickly released and it is allowed to penetrate the cement paste. In the beginning the needle penetrates completely. It is then taken out and dropped at a fresh place.
- This procedure is repeated at regular intervals till the needle does not penetrate the block for about 5 mm measured from the bottom of indicator. Note the time for initial setting of cement. The initial setting time of an ordinary Portland cement shall not be less than 30 minutes.

### Final setting time:

- After noting the time for initial setting of cement, the needle shall be replaced by the final setting time needle.
- The movable rod is slowly released on to the cement paste.
- In the initial stages the needle and collar may pierce through the paste. But after some time the same procedure is followed.
- Such trials shall be carried out until the needle only makes an impression on the top surface of the cement paste and the collar of the needle fails to do so. Note the time for final setting time of cement.
- The final setting time of an ordinary Portland cement shall not be more than 10 hours.

- Result:**
1. Initial setting time of cement =
  2. Final setting time of cement =

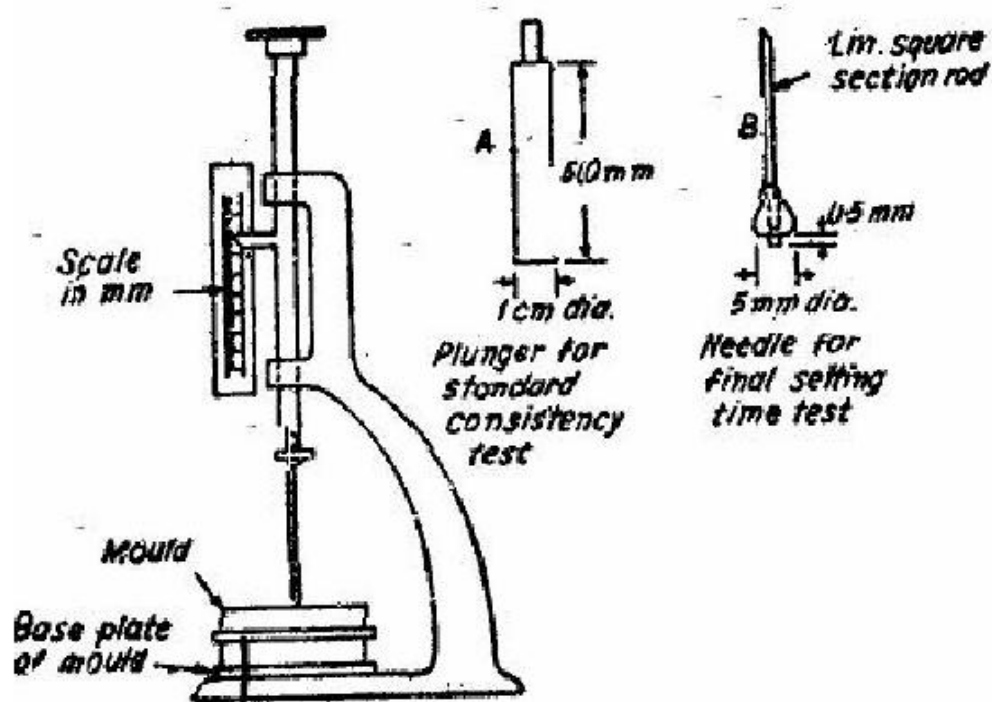

Vicat Apparatus

### Viva Voce:

1. What is Initial setting time of cement?
2. What is Final setting time of cement?
3. Explain why you are performing this experiment?

**Reference:**

1. Indian Standard Methods of Physical Tests for cements IS: 4031, Indian Standards Institution.
2. Indian Standard Specifications for ordinary and low heat Portland cement IS: 269, Indian Standards Institution.
3. Neville. A. M, Properties of concrete, 3<sup>rd</sup> edition, Pitman publishing company, 1981.



## EXPERIMENT NO: 13 SOUNDNESS OF CEMENT

### Theory and Scope:

Unsoundness of cement means, that the cement having excess lime, magnesium sulphates, etc. due to excess of these items there will be volume changes and large expansions, there by reduces the durability of the structures.

**AIM:** -To find out the soundness of cement.

**APPARATUS:** - Le-Chatelier Apparatus Cement, Water , Glass plate.

### Procedure:-

- The cement is gauged with 0.78 times the water required for standard consistency (0.78P) in a standard manner and filled in to the Le-Chatelier mould kept on the glass plate.
- The mould is covered on the top with another glass plate.
- The whole assembly is immersed in water at temperature of 27°C to 32°C and kept there for 24 hrs.
- Measure the distance between the indicator points.
- Submerge the mould again in water, heat the water up to boiling point in 30 minutes and keep it boiling for 3 hrs.
- Remove the mould from hot water and allow it to cool and measure the distance between the indicator points.
- The distance between these two measurements gives the expansion of cement.
- This must not exceed 10mm for OPC, RHC, LHC, etc.
- If the expansion is more than 10mm, the cement is unsound.

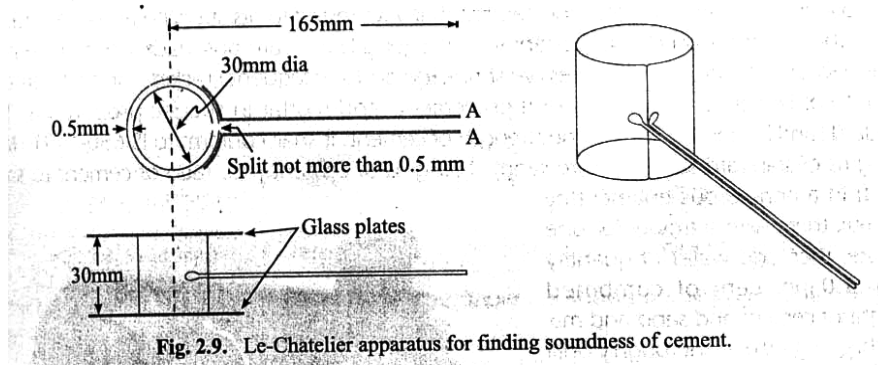

Fig. 2.9. Le-Chatelier apparatus for finding soundness of cement.

**Result:**

soundness of given cement =

**Viva Voce:**

1. What is the significance of this test?

**Reference:**

1. Indian Standard Methods of Physical Tests for cements IS: 4031, Indian Standards Institution.
2. Indian Standard Specifications for ordinary and low heat Portland cement IS: 269, Indian Standards Institution.
3. Neville. A. M, Properties of concrete, 3<sup>rd</sup> edition, Pitman publishing company, 1981.

## **EXPERIMENT NO:14**

### **COMPRESSIVE STRENGTH OF CEMENT**

#### **Theory and Scope:**

The compressive strength of cement mortar is determined strength of cement mortar is determined in order to verify whether the cement conforms to IS specification (IS: 269-1976) and whether it will be able to develop the required compressive strength of concrete. According to IS: 269-1976, the ultimate compressive strength of cubes of cement sand mortar of the ratio 1:3, containing  $(P/4+3.0)$  percent of water should be as.

#### **Aim:**

To determine the compressive strength of 1:3 Cement sand mortar cubes after 3 days and 7 days curing.

#### **Apparatus:**

Universal Testing Machine or Compression Testing Machine, cube moulds, vibrating machine, crucible for mixing cement and sand measuring cylinder, trowels, non-porous plate and balance with weight box.

#### **Procedure:**

- Calculate the material required. The material for each cube shall be mixed separately and the quantities of cement and standard sand shall be as follows:

Cement = 200 gm.

Standard Sand = 600 gm.

Water =  $(P/4+3.0)$  percent = 84 gm.

The time of mixing (gauging) in any event shall not be less than 3 minutes and if the time taken to obtain a uniform colour exceeds 4 minutes the mixture shall be rejected and the operation is repeated with a fresh quantity of cement, sand and water.

- Place the assembled mould on the table of the vibrating machine and firmly hold it in the vibrating machine and firmly hold it in position by means of suitable clamps. Securely attach the hopper at the top of the mould to facilitate filling and this hopper shall not be removed until completion of the vibration period.
- Immediately after mixing the mortar as explained above, fill the entire quantity of mortar
- in the hopper of the cube mould and compact by vibration. The period of vibration shall be 2 minutes at the specified speed of 12000+400 cycles per minute.

- Remove the mould from the machine and keep it at a temperature of  $27 \pm 2^{\circ}\text{C}$  in an atmosphere of at least 90 percent relative humidity for 24 hours after completion of vibrations.
- The cubes are removed from the mould and immediately submerge it in clean and fresh water and keep there until taken out just prior to breaking. The water in which the cubes are submerged shall be renewed after every 7 days and be maintained at a temperature of  $27 \pm 2^{\circ}\text{C}$ , keep the cubes wet till they are placed in machine for testing.
- Test the specimens at the required periods, test three cubes at the periods mentioned below, the periods being reckoned from the completion of vibration. The compressive strength shall be the average of the strengths of the three cubes for each period.
  - a) Ordinary Portland Cement: 3 and 7 days.
  - b) Rapid Hardening Portland Cement: 1 and 3 days.
  - c) Low Heat Portland Cement: 3, 7 and 28 days.

The cubes shall be tested on their sides, the load being applied at the rate of  $35 \text{ N/mm}^2/\text{minute}$ .

**Observation and Calculations:**

**Ordinary Portland cement**

| S.No.          | 3-day strength |                             | 7-day strength |                             |
|----------------|----------------|-----------------------------|----------------|-----------------------------|
|                | Load in KN     | Strength in $\text{N/mm}^2$ | Load in KN     | Strength in $\text{N/mm}^2$ |
| 1              |                |                             |                |                             |
| 2              |                |                             |                |                             |
| 3              |                |                             |                |                             |
| <b>Average</b> |                |                             |                |                             |

**Rapid Hardening Cement**

| S.No.          | 3-day strength |                             | 7-day strength |                             |
|----------------|----------------|-----------------------------|----------------|-----------------------------|
|                | Load in KN     | Strength in $\text{N/mm}^2$ | Load in KN     | Strength in $\text{N/mm}^2$ |
| 1              |                |                             |                |                             |
| 2              |                |                             |                |                             |
| 3              |                |                             |                |                             |
| <b>Average</b> |                |                             |                |                             |

## Rapid Hardening Cement

| S.No.   | 3-day strength |                               | 7-day strength |                               |
|---------|----------------|-------------------------------|----------------|-------------------------------|
|         | Load in KN     | Strength in N/mm <sup>2</sup> | Load in KN     | Strength in N/mm <sup>2</sup> |
| 1       |                |                               |                |                               |
| 2       |                |                               |                |                               |
| 3       |                |                               |                |                               |
| Average |                |                               |                |                               |

### Viva Voce:

1. What you understand by term ultimate strength of cement?
2. What precautions do you take during determination of compressive strength?
3. What is the significance of this test?

### References:

1. Neville A.M, properties of concrete, 3<sup>rd</sup>Edn. Pitman Publishing Company, 1981.
2. Gambhir .M.L, Concrete Manual, 4<sup>th</sup>Edn.,DhanpatRai Sons, Delhi

**EXPERIMENT NO:15**  
**WORKABILITY TESTS ON CEMENT CONCRETE**  
**(FRESH CONCRETE)**

**Theory and Scope:**

The workability of fresh concrete is a composite property which includes the diverse requirements of stability, mobility, compatibility, placeability and finishability. There are different methods for measuring the workability. Each of them measures only particular aspects of it and there is really no unique test which measures workability of concrete in its totality. The test measures the relative effort required to change a mass of concrete from one definite shape to another by means of vibration. The amount of effort called remoulding effort is taken as the time in seconds required to complete the change.

**A). SLUMP TEST**

**Aim:**

To determine the workability of the cement concrete by slump test.

**Apparatus:**

Ingredients for the cement concrete, slump mould, IS standard tamping rod, non-porous base plate, etc.

**Procedure:**

- Initially, a known volume of cement concrete is prepared with a required proportion of ingredients and water - cement ratio.
- The slump mould is cleaned for any remaining cement particles or impurities and is properly oiled at the inner surface.
- Then the prepared concrete sample is put into the mould which is placed on a non-porous plate, in 3 layers with a tapping of 25 times for each layer by a standard tamping rod. The extra heap of concrete present on the top of the mould is cut off or leveled off.
- Then the mould is lifted up vertically by taking care not to disturb the cast cement in the mould.
- The nature of slump is analyzed to get the workability of the given cement concrete sample.

**Observation and Calculation:**

**Result:** The total slump observed for given sample = \_\_\_\_\_ cm.

## **B). COMPACTION FACTOR TEST**

### **Aim:**

To determine the workability of cement concrete by compaction factor test.

### **Apparatus:**

Compaction factor apparatus, tamping rod, ingredients of cement concrete.

### **Procedure:**

- Initially a known volume of cement concrete is prepared by required proportion of ingredients and water-cement ratio.
- The compaction factor apparatus is cleaned and the cylinder is properly oiled. The sample freshly prepared is put into the top hopper with the shutter closed.
- Then the clamp is released and the shutter is opened and thus the sample falls into the second hopper whose shutter is closed.
- Then the shutter of the second hopper is also opened to allow the concrete sample into the cylinder.
- Then the cylinder is weighed and the weight of the partially compacted concrete is found by deducting the weight of the cylinder.
- The density of the partially compacted concrete mix is calculated by knowing the volume of the cylinder.
- Then the same sample is filled into the cylinder in 3 layers and each layer is compacted for 25 blows by using a standard tamping rod.
- Then the weight of the fully density of the fully compacted sample is found out as in the above case.
- Then the compaction factor for the given sample of cement concrete is found out by using the formula,

$$\text{Compaction Factor} = \frac{\text{Density of partially compacted cement concrete} \times 100}{\text{Density of fully compacted cement concrete}}$$

**Observation and Calculation:**

**Mass of Cylinder  $W_1$ :**

| S.I. No | Water cement ration | Mass partially compacted concrete ( $W_2$ ) | Mass fully compacted concrete ( $W_3$ ) | Mass partially compacted concrete ( $W_2 - W_1$ ) | Mass fully compacted concrete ( $W_3 - W_1$ ) | $C.F = \frac{(W_2 - W_1)}{(W_3 - W_1)}$ |
|---------|---------------------|---|---|---|---|---|
| 1       |                     |   |   |   |   |   |
| 2       |                     |   |   |   |   |   |
| 3       |                     |   |   |   |   |   |

**Result:** The compaction factor of the given sample of concrete is \_\_\_\_\_%.



## C). VEE-BEE CONSISTOMETER

### **Aim:**

To determine the workability of freshly mixed concrete by the use of Vee-Bee consistometer.

### **Apparatus:**

Vee-Bee apparatus, a cylindrical container and a sheet metal slump cone, standard iron rod, weighing balance and trowels.

### **Procedure:**

- Place the sheet metal slump cone in the cylindrical container of the consistometer. Fill the cone in four layers, each approximately one quarter of the height of the cone.
- Tamp each layer with twenty five strokes of the rounded end of the tamping rod. The strokes are distributed in a uniform manner over the cross-section uniform manner over the cross-section of the cone and for the second and subsequent layers the tamping bar should penetrate into the under laying layer. After the top layer has been tamped, struck off level the concrete with trowel so that the cone is exactly filled.
- Move the glass disc attached to the swivel arm and place it just on the top of the slump cone in the cylinder container. Adjust the glass disc so as to touch the top of the concrete cone, and note the initial reading on the graduated rod.
- Remove the cone from the concrete immediately by raising it slowly and carefully in the vertical direction. Lower the transparent disc on the top of concrete. Note down the reading on the graduated rod.
- Determine the slump by taking the difference between the readings on the graduated rod recorded in the steps (2) and (3) above.
- Switch on the electrical vibrations and start the stop watch. Allow the concrete to remould by spreading out in the cylindrical container. The vibrations are continued until the concrete is completely remoulded, i.e., the surface becomes horizontal and the whole concrete surface adheres uniformly to the transparent disc.
- Record the time required for complete remoulding seconds which measures the workability expressed as number of Vee-Bee seconds.

**Observation and Calculation:**

|  |  |  |
|--|--|--|
| <b>Initial reading on the graduated rod, a</b> |  |  |
| <b>Final reading on the graduated rod, b</b>   |  |  |
| <b>Slump (b) - (a), mm</b>                     |  |  |
| <b>Time for complete remoulding, seconds</b>   |  |  |

**Results:**

The consistency of the concrete is \_\_\_\_\_ sec.

**Observations and Calculations:**

**Result:** The optimum binder content of the given mix is \_\_\_\_\_

**Viva Voce:**

1. What is the significance of flow value in Marshall Test?
2. What is filler?
3. What are the essential properties of bituminous mixes?

**Reference:**

1. Neville A.M, properties of concrete, 3<sup>rd</sup>Edn. Pitman Publishing Company, 1981.
2. Gambhir .M.L, Concrete Manual, 4<sup>th</sup>Edn.,DhanpatRai Sons, Delhi

## EXPERIMENT NO:16 BULKING OF SAND

### Theory and Scope:

The volume of fine aggregate may increase by 1% to 5% due to presence of moisture. This property of increase in volume of fine aggregate due to moisture is called bulking.

### AIM:

To find out the bulking factor of fine aggregate.

### APPARATUS:

Container, Sand, Water, Mixing Pan.

### Procedure:

- Take about 6 liters of dry compacted sand and weigh it and dump it into a mixing pan.
- Add a certain known percentage of water by weight of dry sand.
- Mix rapidly and thoroughly till a uniform colour is obtained and fill the container with the wet sand with out any tamping.
- Now strike off the top surface and weigh and thus find the weight of wet sand.
- Repeat the experiment No. of times increasing in water content from 1% to 20%.
- Calculations:-

$W_1 = \text{Wt. of } 1\text{m}^3 \text{ of compacted dry sand.}$

$W_2 = \text{Wt. of dry sand contained in } 1\text{m}^3 \text{ of wet loose sand.}$

$W_3 = \text{Wt. of } 1\text{m}^3 \text{ of wet sand}$

$X = \text{Percentage of water added}$

$W_3 = \text{Wt. of dry sand} + \text{Wt. of water}$

$$W_3 = W_2 \left(1 + \frac{x}{100}\right)$$

$$W_2 = \frac{W_3}{1 + \frac{x}{100}}$$

$$\therefore \% \text{ of bulking} = \frac{W_1 - W_2}{W_1} \times 100$$

$$\text{Bulking factor} = \frac{w_1}{\dots}$$

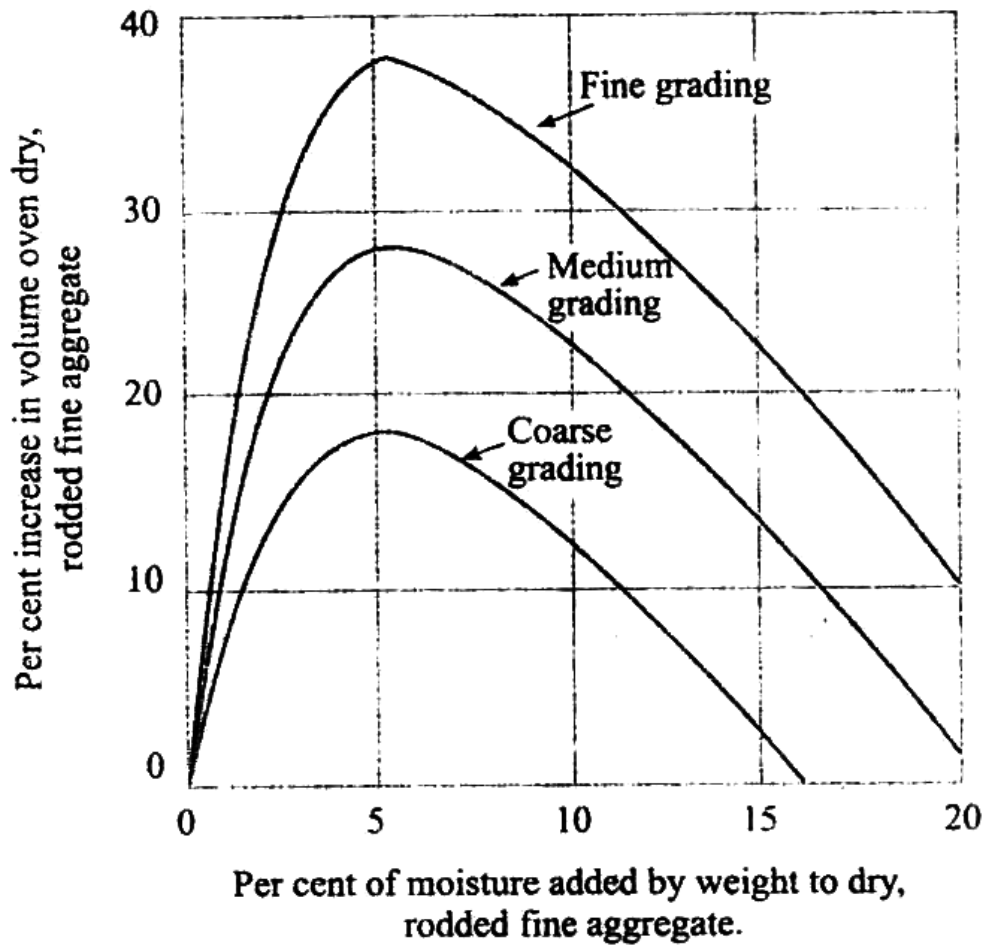

**RESULT:**

Bulking of given Sand = ----- % of water

\_\_\_\_\_

**References:**

1. Neville A.M, properties of concrete, 3<sup>rd</sup>Edn. Pitman Publishing Company, 1981.
2. Gambhir .M.L, Concrete Manual, 4<sup>th</sup>Edn.,DhanpatRai Sons, Delhi