

AC MACHINES LABORATORY

LAB MANUAL

Academic Year : 2018- 2019

Course Code : AEE106

Regulations : IARE – R16

Class : II Year II Semester (EEE)



Department of Electrical and Electronics Engineering

INSTITUTE OF AERONAUTICAL ENGINEERING
(Autonomous)

Dundigal – 500 043, Hyderabad



INSTITUTE OF AERONAUTICAL ENGINEERING

(Autonomous)

Dundigal, Hyderabad - 500 043

ELECTRICAL AND ELECTRONICS ENGINEERING

Program Outcomes	
PO1	Engineering Knowledge: Apply the knowledge of mathematics, science, engineering fundamentals, and an engineering specialization to the solution of complex engineering problems.
PO2	Problem Analysis: Identify, formulate, review research literature, and analyze complex engineering problems reaching substantiated conclusions using first principles of mathematics, natural sciences, and engineering sciences.
PO3	Design / Development of Solutions: Design solutions for complex engineering problems and design system components or processes that meet the specified needs with appropriate consideration for the public health and safety, and the cultural, societal, and environmental considerations.
PO4	Conduct Investigations of Complex Problems: Use research - based knowledge and research methods including design of experiments, analysis and interpretation of data, and synthesis of the information to provide valid conclusions.
PO5	Modern Tool Usage: Create, select, and apply appropriate techniques, resources, and modern engineering and IT tools including prediction and modeling to complex engineering activities with an understanding of the limitations.
PO6	The Engineer and Society: Apply reasoning informed by the contextual knowledge to assess societal, health, safety, legal and cultural issues and the consequent responsibilities relevant to the professional engineering practice.
PO7	Environment and Sustainability: Understand the impact of the professional engineering solutions in societal and environmental contexts, and demonstrate the knowledge of, and need for sustainable development.
PO8	Ethics: Apply ethical principles and commit to professional ethics and responsibilities and norms of the engineering practice.
PO9	Individual and Team Work: Function effectively as an individual, and as a member or leader in diverse teams, and in multidisciplinary settings.
PO10	Communication: Communicate effectively on complex engineering activities with the engineering community and with society at large, such as, being able to comprehend and write effective reports and design documentation, make effective presentations, and give and receive clear instructions.
PO11	Project Management and Finance: Demonstrate knowledge and understanding of the engineering and management principles and apply these to one's own work, as a member and leader in a team, to manage projects and in multidisciplinary environments.
PO12	Life - Long Learning: Recognize the need for, and have the preparation and ability to engage in independent and life - long learning in the broadest context of technological change.
Program Specific Outcomes	
PSO1	Professional Skills: Able to utilize the knowledge of high voltage engineering in collaboration with power systems in innovative, dynamic and challenging environment, for the research based team work.
PSO2	Problem - Solving Skills: Can explore the scientific theories, ideas, methodologies and the new cutting edge technologies in renewable energy engineering, and use this erudition in their professional development and gain sufficient competence to solve the current and future energy problems universally.
PSO3	Successful Career and Entrepreneurship: The understanding of technologies like PLC, PMC, process controllers, transducers and HMI one can analyze, design electrical and electronics principles to install, test , maintain power system and applications.

INDEX

S.No	List of Experiments	Page No
1	Determine the equivalent circuit parameters; predetermine the efficiency and regulation by open circuit and short circuit test in a single phase transformer.	6 - 9
2	Predetermine the efficiency and regulation of two identical single phase transformers.	10 - 13
3	Conversion of three phases to two phase using single phase transformers.	14 - 15
4	Find out the Eddy current and Hysteresis losses in single phase transformer.	16 - 18
5	Determine the temperature rise in a 1- ϕ transformer using back-back test.	19 - 21
6	Plot the performance characteristics of three phase induction motor	22 - 24
7	Plot the circle diagram and predetermine the efficiency and losses of 3 - ϕ squirrel cage induction motor.	25 - 29
8	Determine the regulation of alternator using synchronous impedance method.	30 - 32
9	Determination of X_d and X_q in a three phase salient pole synchronous motor.	33 - 35
10	Plot 'V' and 'inverted 'V' curves to study the effect of power factor in synchronous motor.	36 - 38
11	Determine the equivalent circuit parameters of a single phase induction motor.	39 - 41
12	Determine the efficiency and regulation by open circuit and short circuit test in a single phase transformer using digital simulation.	42 - 45
13	Scott connection of transformer using digital simulation.	45 - 46
14	Speed control of 3- ϕ slip ring induction motor with rotor resistance cutting using PLC; Implementation of star-delta starter using PLC	47 - 52

ATTAINMENT OF PROGRAM OUTCOMES & PROGRAM SPECIFIC OUTCOMES

Exp.No	Experiment	Program Outcomes Attained	Program Specific Outcomes Attained
1	Open circuit & Short circuit test on a single phase Transformer	PO1, PO2	PSO1
2	Sumpners test on a pair of single phase transformers	PO1, PO3	PSO1
3.	Scott Connection of Transformers	PO1, PO3, PO9	PSO1
4.	Separation of core losses in 1- ϕ Transformer	PO1, PO2, PO3	PSO2
5.	Heat Run Test on a bank of three numbers of single phase delta connected transformers	PO1, PO3, PO9	PSO1
6.	Brake test on 3 - ϕ Squirrel cage Induction motor	PO1, PO3	PSO1
7.	Circle diagram of 3 - ϕ slip ring induction motor	PO1, PO3, PO8	PSO1
8.	Regulation of alternator using Synchronous impedance method	PO1, PO3, PO9	PSO1, PSO2
9.	Slip test on 3- ϕ salient pole synchronous motor	PO1, PO2	PSO1
10.	'V' and 'Inverted V' curves of Synchronous motor	PO1, PO2, PO9	PSO1
11.	No load and blocked rotor test on 1- ϕ Induction Motor	PO1, PO2	PSO1, PSO2
12.	Determination Of Losses In 1- ϕ Transformer Using Digital Simulation	PO1, PO2	PSO2, PSO3
13.	Three Phase To Two Phase Conversion In 1- ϕ Transformer Using Digital Simulation	PO1, PO3, PO9	PSO2, PSO3
14.	Starting; Speed Control Of 3- ϕ Slip Ring Induction Motor Using Plc	PO1, PO3	PSO2, PSO3

AC MACHINES LAB

OBJECTIVE:

The objective of the AC Machines Laboratory is to expose students to the concepts of single phase and three phase transformers, synchronous and asynchronous machines and analyze their performance. It aims to impart knowledge on construction, performance and principle of operation of transformers, salient, non – salient type synchronous generator and induction machines. The starting and speed control of three-phase induction motors and single phase induction motors is also studied.

OUTCOMES:

Upon the completion of AC Machines practical course, the student will be able to attain the following:

1. Familiarity with the types of synchronous, asynchronous, transformers and their basic characteristics.
2. Ability to make a right decision related to a choice of the motor for a particular system in the industrial environment.
3. Understanding of the concepts of power and efficiency.
4. Understand the concept of efficiency and the short circuit impedance of a single-phase transformer from no - load test, winding resistance, short circuit test, and load test.
5. Understand the starting and connecting procedures of synchronous generators, and to obtain the ‘V’ and inverted ‘V’ curves of synchronous motors.
6. Experimentally obtain the load characteristics, starting current and starting torque of a three phase and single phase induction motor and to derive circuit parameters from no - load and blocked-rotor tests.

EXPERIMENT - 1

OPEN CIRCUIT AND SHORT CIRCUIT TESTS ON 1- ϕ TRANSFORMER

1.1 AIM:

To conduct the open and short circuit tests on a single phase transformer to determine core losses, copper losses, and hence determine regulation, efficiency and the parameters of the equivalent circuit.

1.2 NAME PLATE DETAILS:

KVA rating	
Voltage rating	

1.3 APPARATUS:

S. No.	Equipment	Type	Range	Quantity
1	Ammeter			
2	Ammeter			
3	Voltmeter			
4	Voltmeter			
5	Wattmeter			
6	Wattmeter			

1.4 CIRCUIT DIAGRAM:

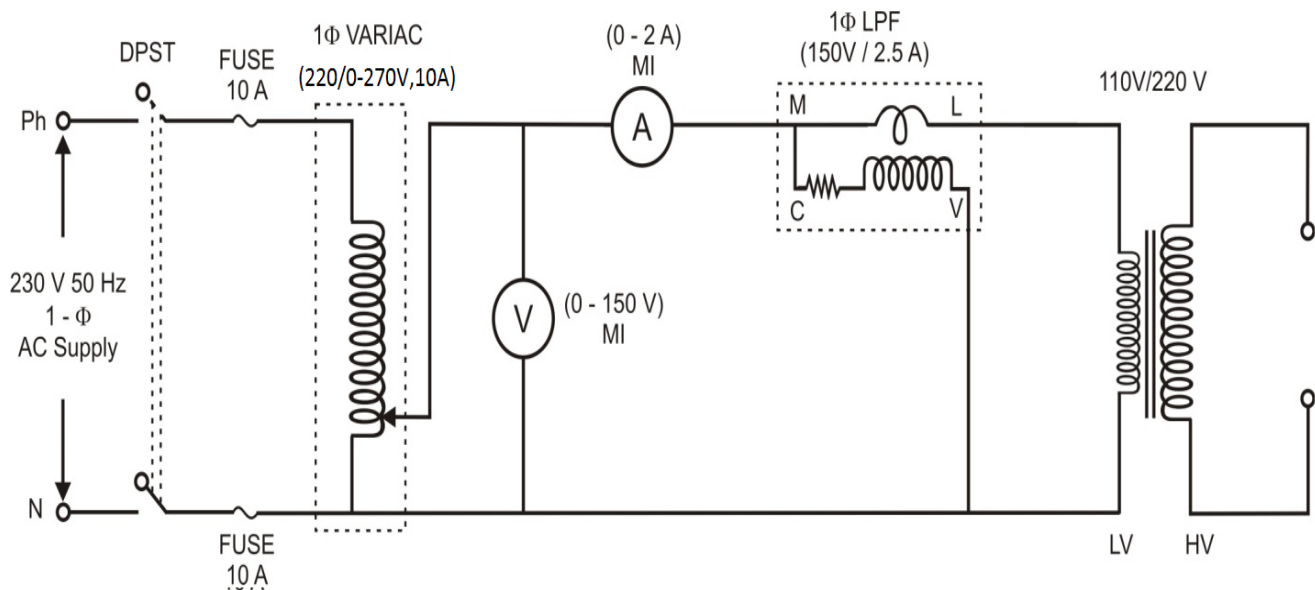

Fig – 1.1 OC Test on Single Phase Transformer

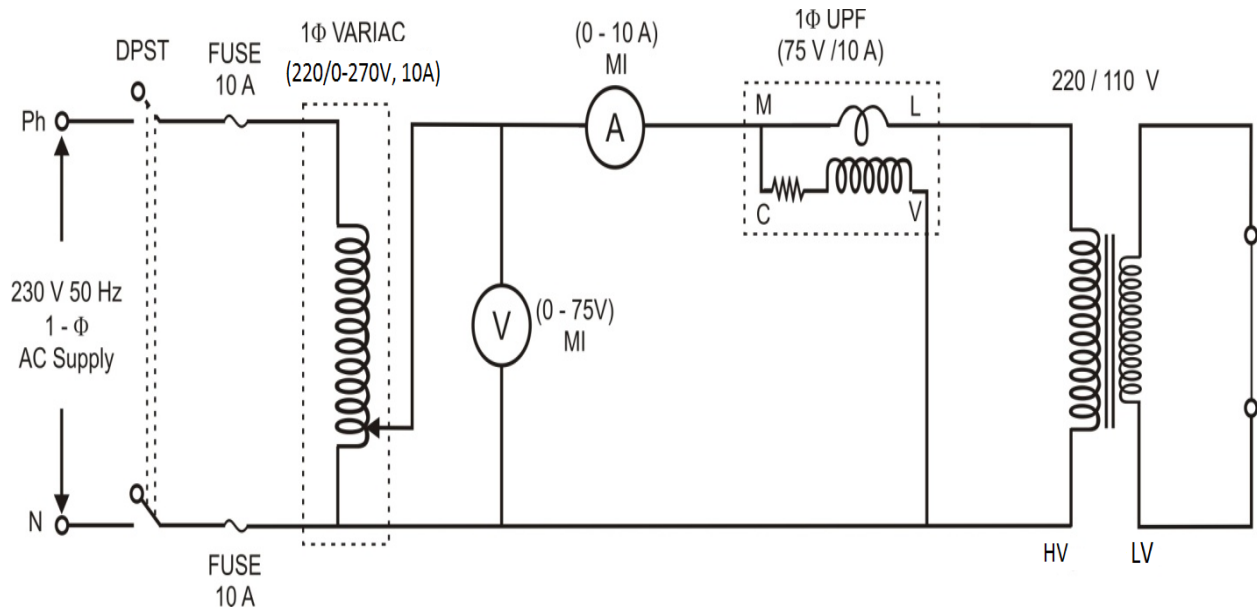

Fig – 1.2 SC Test on Single Phase Transformer

1.5 PROCEDURE:

O. C TEST:

1. Make the connections as per the circuit diagram.
2. Apply rated voltage with the help of autotransformer across LV winding, with the HV winding as open circuited.
3. Note down the readings of voltmeter (V), Ammeter (I_o) and wattmeter (P_o).

1.6 CALCULATIONS:

Iron losses, $P_I = P_o$ watts.

$$\text{No load P.f., } \cos \phi_o = \frac{P_o}{VI_o}$$

$$\text{Magnetizing current, } I_m = I_o \sin \phi_o$$

$$\text{Loss component of no load current, } I_w = I_o \cos \phi_o$$

$$\text{Magnetizing reactance, } X_o = \frac{V}{I_m}$$

$$\text{Equivalent resistance of iron losses, } R_o = \frac{V}{I_w}$$

1.7 PROCEDURE:

S. C TEST:

1. Make the connections as per the circuit diagram.
2. Adjust supply voltage by 1-φ Auto transformer such that the current through the transformer is the rated value and note down all meter readings.

1.8 CALCULATIONS:

Full load copper losses $P_{Cu} = P_{SC}$ Watts.

Power factor on short circuit, $\cos \phi_{sc} = \frac{P_{sc}}{V_{sc} I_{sc}}$

Short circuit impedance $Z_{01} = \frac{V_{sc}}{I_{sc}} \Omega$.

Referred to primary:

HT equivalent resistance, $R_{01} = \frac{P_{sc}}{I_{sc}^2}$.

HT equivalent reactance, $X_{01} = \sqrt{Z_{01}^2 - R_{01}^2}$

a) **EFFICIENCY:** At X times full load and power factor $\cos \phi$, output, $P_0 = X \cdot S \cos \phi$ kW

Where S = KVA rating of the transformer.

Input = Output + Iron Loss + $x^2 \cdot P_{Cu}$

% efficiency (η) = Output / Input * 100

1. Calculate the efficiency of the transformer at Unity, 0.8 and 0.6 Power factors for 1/4, 1/2, 3/4, full load and draw the output characteristics.

2. Calculate the maximum efficiency corresponding to the maximum load.

b) **REGULATION:** Regulation is defined as percentage drop in voltage from no load to full load at any power factor due to voltage drops in resistance and leakage reactance of the transformer.

1. Calculate the percentage resistance voltage drop ($\% V_R$) = $I_1 R_1 / V_1 \times 100$

2. Calculate the percentage reactance voltage drop ($\% V_x$) = $I_1 X_1 / V_1 \times 100$.

2. Calculate the percent regulation, = $\% V_R \cos \phi + \% V_x \sin \phi$ at Unity, 0.8, 0.6 leading and lagging power factors

1.9 EXPECTED CURVES:

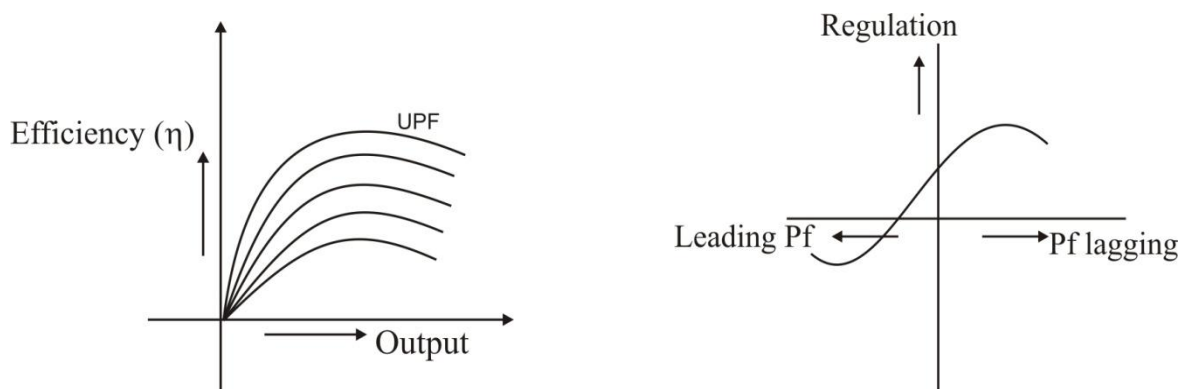

Fig – 1.3 Performance of the Single Phase Transformer

1.10 TABULAR COLUMN:

PART - I: Efficiency Curve

S.No.	x	Po	Pi	η
1.				

PART - II: Regulation Curve at Full Load

S. No.	Power Factor	Regulation
1.		

1.11 PRECAUTIONS:

1. Loose connections are avoided.
2. Note down all meter readings without any parallax error.

1.12 RESULT:

1.13 PRE LAB VIVA QUESTIONS:

1. Which losses are called magnetic losses?
2. Write equations for hysteresis and eddy - current losses.
3. Why O.C test is conducted on LV side?
4. Why S.C test will conducted on HV side?
5. Why transformer fails to operate on D.C supply?
6. Explain why low power factor meter is used in O.C test.

1.14 POST LAB VIVA QUESTIONS

1. Why the iron losses are neglected when S.C test on a Transformer?
2. Draw the phasor diagram for a S.C. test on a transformer.
3. How do you reduce the hysteresis and eddy-current losses?
4. Under what condition the regulation of a transformer becomes zero?
5. Define voltage regulation with equation for lagging and leading loads.
6. Generally what is the efficiency percentage of a transformer?
7. What is the condition for maximum efficiency?

EXPERIMENT - 2

SUMPNERS TEST ON A PAIR OF 1- Φ TRANSFORMERS

2.1 AIM

To conduct Sumpners test on a pair of identical single phase transformers and hence determine the equivalent circuit parameters and efficiency.

2.2 NAME PLATE DETAILS:

KVA rating	
Voltage rating	

2.3 APPARATUS:

S. No.	Name	Type	Range	Quantity
1	Variac			
2	Voltmeter			
3	Voltmeter			
4	Ammeter			
5	Ammeter			
6	Wattmeter			
7	Wattmeter			

2.4 CIRCUIT DIAGRAM:

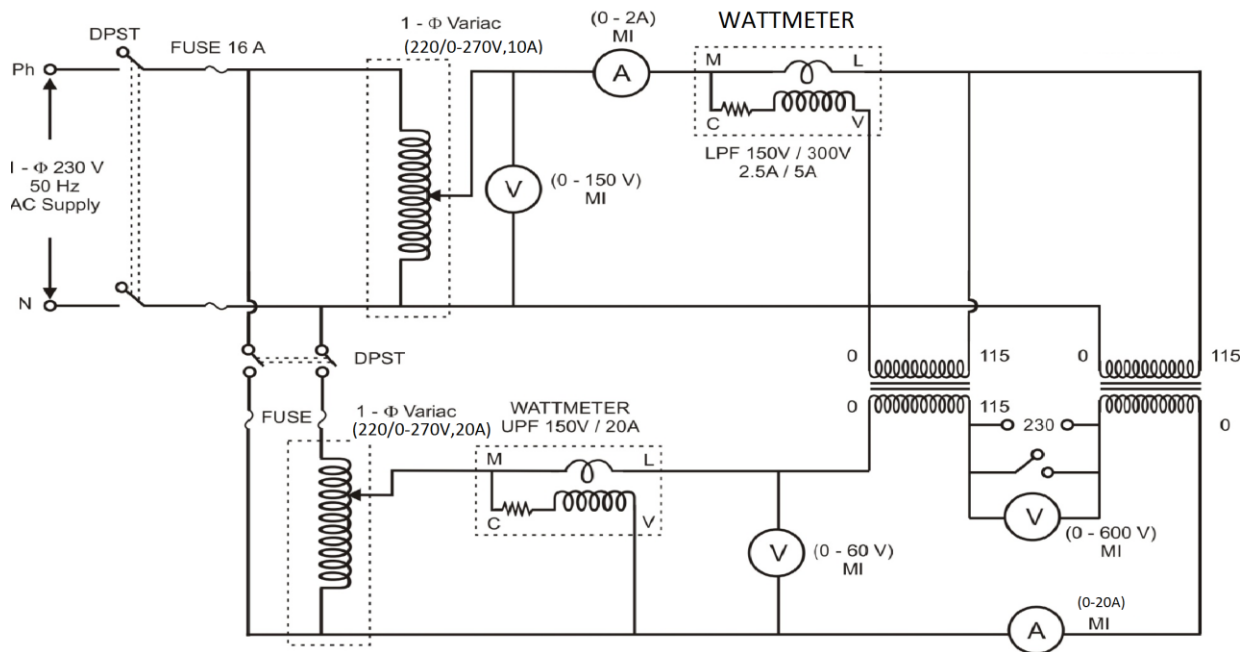

Fig – 2.1 Sumpners test on a pair of 1- Φ Transformers

2.5 PROCEDURE:

1. Connect the circuit as per the circuit diagram
2. The primaries are connected in parallel to the 115V supply, keeping switch (S1) open.
4. If the polarities are appropriate, V3 should read Zero (otherwise it will read two times the rated secondary voltage; then one of the Secondary's has to be reverse connected).
5. When V3 reads zero, switch (S1) is closed and a low voltage is injected into the secondary winding, such that rated current is circulated.
6. This is only a circulation current in the secondary and does not cause any equivalent current to be drawn by the primaries from the supply.
7. The reflected current in the primaries flows as the circulating current in the closed loop formed by two primaries. This reflected current does not flow from the supply. It is to be noted that the net power drawn from the supply is only power corresponding to no load losses.
8. Tabulate meter readings and calculate the circuit parameters.

2.6 CALCULATIONS:

Predetermination of Efficiency:

$$\text{No load losses} = \frac{W_o}{2} \quad \text{for each Transformer}$$

$$\text{Copper losses} = \frac{W_{sc}}{2} \quad \text{for each Transformer}$$

$$\eta_{At FL} = \frac{FL \text{ power}}{(FL \text{ power} + \text{No load lossess} + FL \text{ Copper lossess})}$$

$$\eta_{At \frac{1}{2} FL} = \frac{\frac{1}{2} FL \text{ power}}{\frac{1}{2} FL \text{ power} + \text{No load lossess} + \left(\frac{1}{2}\right)^2 FL \text{ copper lossess}}$$

$$\text{No load current} = \frac{I_o}{2} \text{ per transformer}$$

$$\text{Voltage applied} = V_o$$

Using these values the Values of R_o & X_o are calculated as in the OC test

$$W_o = V_o I_o \cos\theta_o$$

$$\text{i.e., } \cos\theta_o = (W_o/2) / (V_o * [I_o/2]) \quad (\text{for each transformer})$$

$$I_w = [I_o/2] \cos\theta_o$$

$$I_m = [I_o/2] \sin\theta_o$$

$$R_o = V_o / I_w$$

$$X_o = V_o / I_m$$

$$\text{SC current} = I_2 = I_{sc}$$

$$\text{SC voltage} = V_2/2 = V_{sc}$$

$$\text{SC power} = W_2/2 = W_{sc}$$

Using these values, the series parameters R_{o2} and X_{o2} (referred to secondary) are calculated as in the sc test.

$$W_{sc} = I_{sc}^2 R_{o1}$$

$$R_{o1} = W_{sc} / I_{sc}^2$$

$$Z_{o1} = V_{sc} / I_{sc}$$

$$X_{o1} = \sqrt{(Z_{o1}^2 - R_{o1}^2)}$$

$$R_{o2} = R_{o1} K^2$$

$$X_{o2} = X_{o1} K^2$$

2.7 MODEL GRAPH:

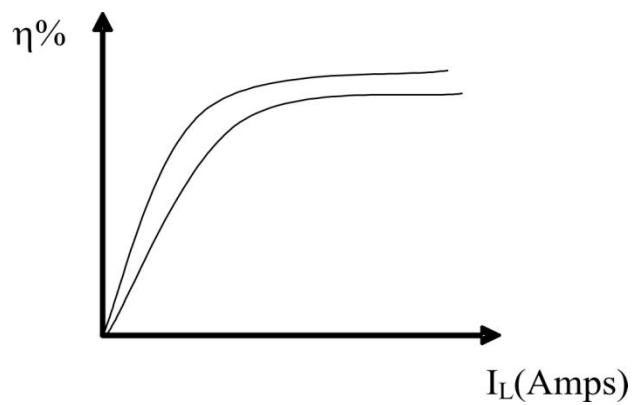

Fig – 2.2 Performances on a Pair of 1-Φ Transformers

2.8 TABULAR COLUMN:

S.No	$V_o(V)$	$I_o(A)$	$W_o(W)$	$V_2(V)$	$I_2(A)$	$W_2(W)$
1.						

2.9 PRECAUTIONS:

1. Loose connections are avoided.
2. Note down all meter readings without any parallax error.

2.10 RESULT:

2.11 PRE LAB VIVA QUESTIONS:

1. Why two identical transformers are required for back to back test?
2. What is the material kept inside a breather?
3. Write the relations between line-currents, phase-currents and line voltage, phase voltages in a star and delta connections?
4. Draw star/star, star / delta, delta / delta delta / star winding connections when three single phase transformers are used.
5. What is the use of tertiary winding in a transformer?

2.12 POST LAB VIVA QUESTIONS

1. How can you use a 3 - phase auto - transformer as a step-up auto-transformer?
2. Explain the working principle of back to back transformer test.
3. Why the core is made of silicon steel laminations?
4. What is the role of Buchholz relay?
5. At which load transformer can give maximum efficiency?
6. Differentiate Sumpners test and O.C and S.C tests on transformer.

EXPERIMENT - 3

SCOTT CONNECTION OF TRANSFORMERS

3.1 AIM:

To conduct Scott connection of transformers and verify the relations between primary and secondary voltages and currents are as per the theoretical prediction.

3.2 NAME PLATE DETAILS:

KVA Rating	
Voltage rating	

3.3 APPARATUS:

Name	Range	Type	Quantity
Voltmeters			
Voltmeters			
Ammeter			
Ammeter			

3.4 CIRCUIT DIAGRAM:

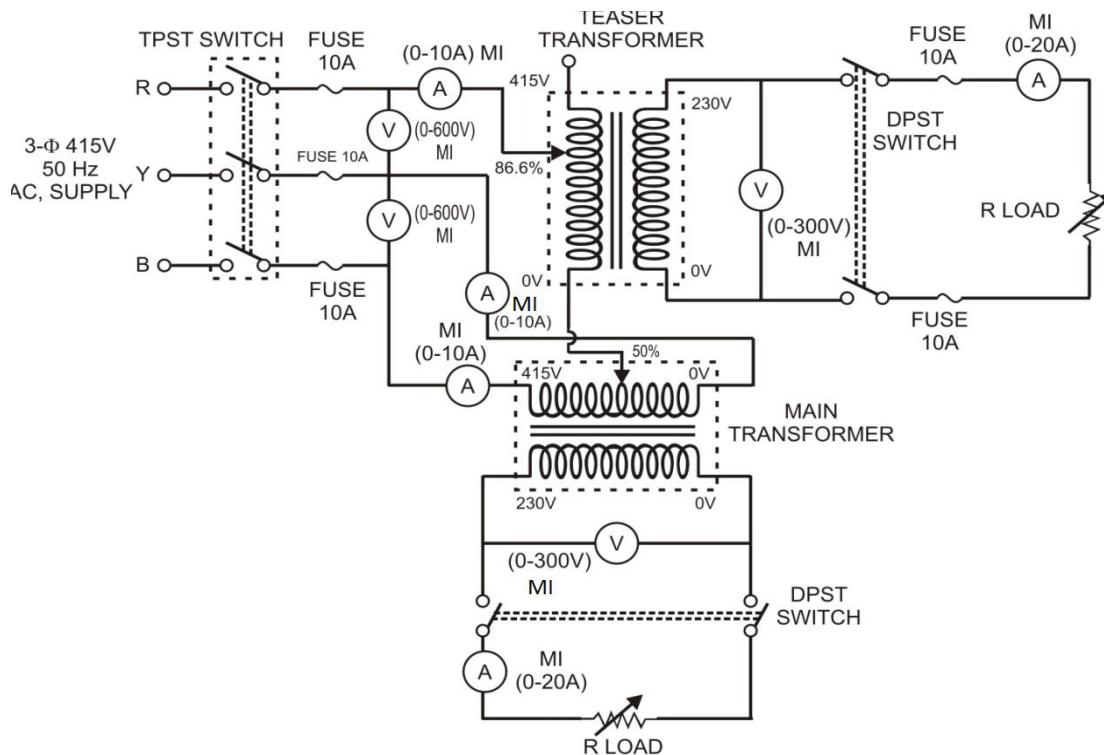

Fig – 3.1 Scott Connections of Transformers

3.5 PROCEDURE:

1. Make the connections as per the circuit diagram with meters of suitable ranges.
2. Connect loads to the secondary side of the two transformers.
3. Gradually increase the load current on both transformers and note the readings of load currents and voltages.

3.6 TABULAR COLUMN:

S.No	I_R (A)	I_Y (A)	I_B (A)	V_{RY} (V)	V_{YB} (V)	V_{TS} (V)	I_{TS} (A)	V_{MS} (V)	I_{MS} (A)
1.									

3.7 PRECAUTIONS:

1. The main transformer tapping should be kept at 50%.
2. The teaser transformer tapping should be kept at 86.6%.

3.8 RESULT:

3.9 PRE LAB VIVA QUESTIONS:

1. What is the use of Scott connection?
2. Compare open delta, Scott connections.
3. How the Scott connection is formed?
4. One transformer has cruciform type and second transformer has square type of core which is the better one?
5. Draw the phasor diagram for Scott connection.

3.10 POST LAB VIVA QUESTIONS:

1. Draw the phasor diagrams for leading and lagging loads.
2. For a step-down transformer which winding has low resistance?
3. What is the full name of C.R.G.O.S core material?
4. How 6 phase supply is produced? Where it is used?
5. What happens in tap changing in a transformer?
6. For which winding the tap changing is provided?

EXPERIMENT – 4

SEPARATION OF CORE LOSSES OF A 1-Φ TRANSFORMER

4.1 AIM:

To separate Hysteresis and eddy current losses of a given single phase transformer at no load condition

4.2 NAME PLATE DETAILS:

1-Φ Transformer		Alternator		DC Shunt Motor	
Voltage		Voltage		Voltage	
Current		Current		Current	
Frequency		Frequency		Speed	
KVA		KVA		HP	

4.3 APPARATUS:

S.No.	Equipment	Range	Type	Quantity
1	Ammeter			
2	Voltmeter			
3	Wattmeter			

4.4 CIRCUIT DIAGRAM:

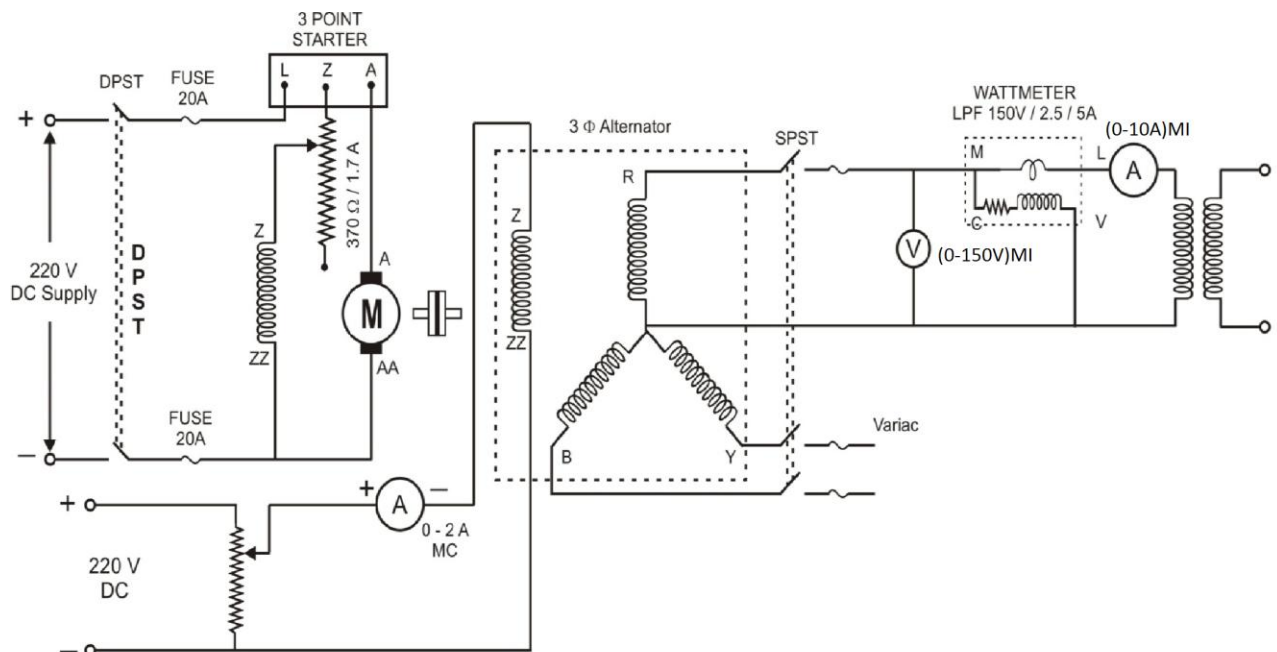

Fig – 4.1 Separation of Core Losses of a 1-Φ Transformer

4.5 PROCEDURE:

1. Make the connection as per the circuit diagram
2. Start the alternator with the help of prime mover (DC Motor).
3. Adjust the speed of the prime mover so that the alternator frequency should be 50 Hz.
4. Vary the excitation of the alternator so that the required voltage builds across the armature (Say 230 V between line and neutral).
5. Note down all meter readings.
6. Repeat the above steps for different frequencies by changing the speed of the prime mover (With Speed control of DC Shunt motor by Armature control or Field Control).
7. Repeat step 6 for different frequencies of the alternator by varying the speed of DC motor so that V / f ratio is maintained constant.
8. Plot the graph between W/f and frequency of the transformer.

4.6 TABULAR COLUMN:

S. No.	Speed (N) rpm	Frequency (Hz)	Voltage (volts)	W/f	Current (amps)	W (watts)

Frequency Hz	W_h (watts)	W_e (watts)	W_T (watts)

4.7 MODEL GRAPH:

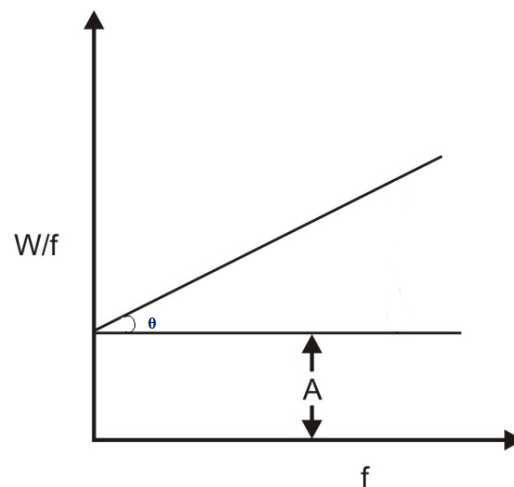

Fig - 4.2 Graph plotted between W/f and core losses (W_T)

4.8 CALCULATION:

Hysteresis loss and eddy current loss are the components of the iron losses. For the applied flux density B_{max} to the core, we have

Hysteresis loss = Af

and Eddy current loss = Bf^2 ($B=\text{Tan}\theta$)

The no load loss can be expressed as

$$W_c = A_f + B_f^2$$

where A and B are constants.

4.9 PRECAUTIONS:

1. Loose connections are avoided.
2. Note down all meter readings without any parallax error.

4.10 RESULT:

4.10 PRE LAB VIVA QUESTIONS:

1. What factors does the core losses depend?
2. How the core losses of a transformer can reduce?
3. What is the relation between flux density and (V / f) ratio?

4.11 POST LAB VIVA QUESTIONS

1. Why V / f ratio is maintained constant?
2. How V / f ratio maintained constant?

EXPERIMENT – 5

HEAT RUN TEST ON BANK OF 3 NUMBER OF SINGLE PHASE DELTA CONNECTED TRANSFORMERS

5.1 AIM:

To measure the rise in temperature inside the winding of a 3- phase transformer using Heat -Run test

5.2 NAME PLATE DETAILS:

KVA Rating	
Voltage rating	

5.3 APPARATUS:

S. No	Equipment	Range	Type	Quantity
1	Ammeter			
2	Ammeter			
3	Voltmeter			
4	Voltmeter			
5	Wattmeter			

5.4 PROCEDURE:

1. Make the connections as per the circuit diagram
2. Keep the switch in the off position.
3. Switch on the 3-phase power supply.
4. Record the Ammeter, Voltmeter readings on the primary side and observe the reading on the Secondary side.
5. If the voltmeter indicates high value then conduct the polarity test and connect them as per the dot Convention.
6. If this voltmeter indicates zero, then switch on Sw1 and slowly increase the auto transformer till the Ammeter indicates the rated current of the secondary winding 8.2 Amps.
7. Draw the graph between temperatures Vs. time.

5.5 CIRCUIT DIAGRAM:

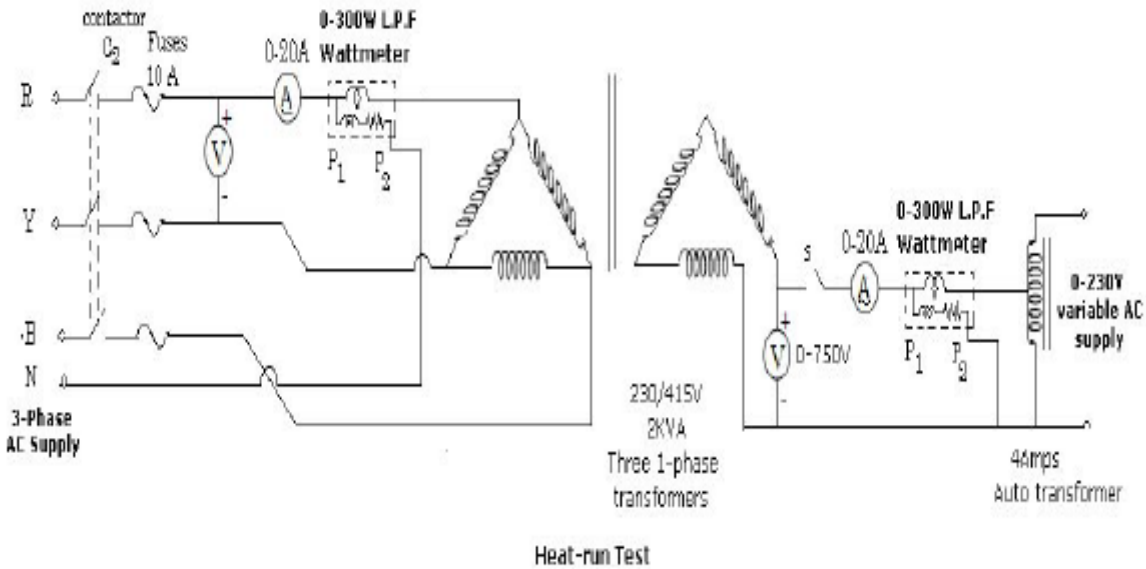

5.1 Single phase delta connected transformers

5.6 TABULAR COLUMN:

S. No	Current(A)	Copper Losse(Watt meter reading)
1		
2		
3		

5.7 TABULAR COLUMN:

S. No	Time (Min)	Temperature (°C)
1		
2		
3		
4		
5		
6		

5.8 PRECAUTIONS:

1. Loose connections are avoided.
2. Note down all meter readings without any parallax error.

5.9 RESULT:

5.10 PRE LAB VIVA QUESTIONS:

1. What is a transformer?
2. Is it Possible to change three phase to two phase or vice-versa with standard transformers?
3. How does a transformer Work?
4. What are Taps and when are they Used?
5. What is the difference Between, “insulating”, “isolating”, and “shielded winding” transformers?

5.11 POST LAB VIVA QUESTIONS:

1. Can 50 - Hz transformers be operated at 60 Hz & Vice versa ?
2. Can transformers be used in Parallel?
3. What is meant by regulation in a ttransformer?
4. What is meant by temperature rise in a ttransformer?
5. What is meant by "Impedance" in Transformers

EXPERIMENT - 6

BRAKE TEST ON 3- ϕ SQUIRREL CAGE INDUCTION MOTOR

6.1 AIM:

To obtain the performance characteristics of a 3 - phase squirrel cage induction motor by conducting brake test.

6.2 NAME PLATE DETAILS:

Motor

Rating	
Voltage	
Current	
Speed	

6.3 APPARATUS:

S. No.	Item	Type	Range	Quantity
1	Ammeter			
2	Voltmeter			
3	Wattmeter			
4	3- ϕ Variac			

6.4 CIRCUIT DIAGRAM:

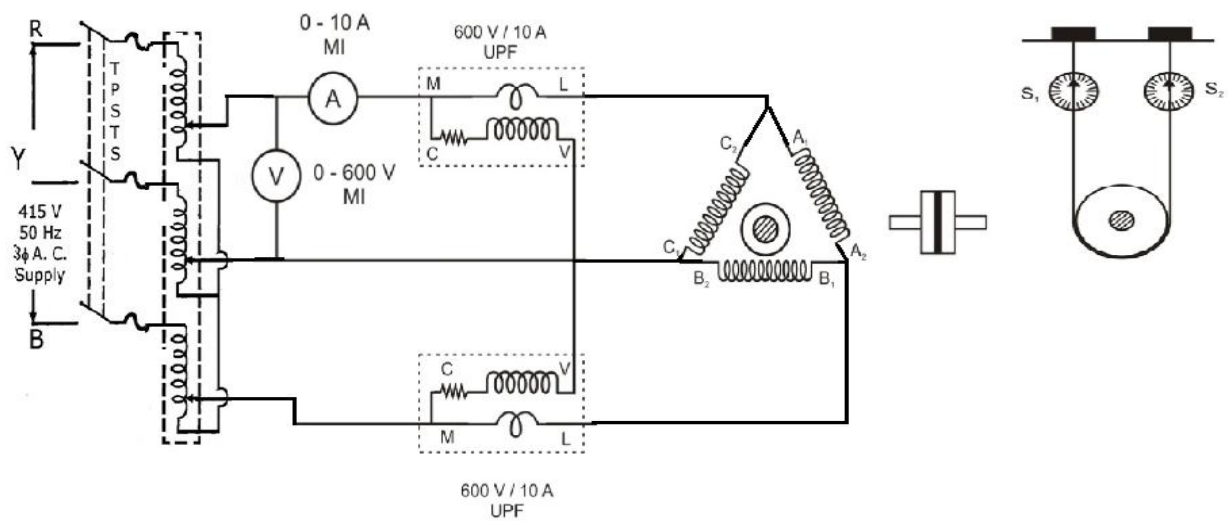

Fig – 6.1 Brake Test on 3- ϕ Induction Motor

6.5 PROCEDURE:

1. Make the connections as per the circuit diagram.
2. Start the 3-Φ IM on no Load by means of three phase auto transformer.
3. Note down all meters reading and the speed at no load.
4. Apply mechanical load by tightening the belt on the brake drum and note down the readings of the meters, spring balances, and the speed.
5. Repeat the above step-4 until the motor draws full load current.
6. Calculate the torque, slip, output, efficiency and power factor for each set of readings as per the model calculations.
7. Draw the performance curves of o/p Vs η , T, N, I_a , and p.f on one graph sheet.

6.6 CALCULATION:

Power input (P_1) = Wattmeter reading x multiplying factor.

Torque, $T = W * g * r$ N-m

Where 'r' is the radius of the break drum.

Where output, $P_o = 2\pi NT/60$. Watts.

% Slip, $s = [N_s - N] / N_s * 100$.

Power Factor ($\cos.\phi$) = $(P_1 \div \sqrt{3}V_L I_L)$

6.7 TABULAR COLUMN:

S. No	V_L (Volts)	I_L (Amp)	W_1 (watts)	W_2 (watts)	N(rpm)	T (Nm)	W rad/s	% slip	Out Put power	Power Factor (cos.φ)	In Put power	% Efficiency
1												
2												
3												
4												
5												

6.8 MODEL GRAPHS:

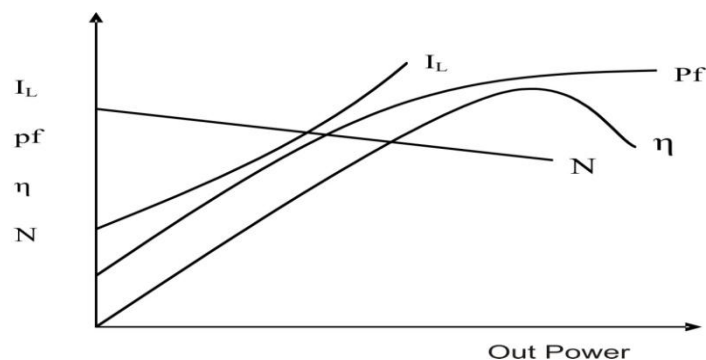

Fig – 6.2 Performance on 3-φ Induction Motor

6.9 RESULT:

6.10 PRE LAB VIVA QUESTIONS:

1. How do you connect the six terminals of the motor as delta or Star?
2. What are the different starting methods used to start induction motors?
3. What is the role of a rotating flux?
4. What is the difference between squirrel cage induction motor and slip ring induction motor?
5. Why the rotor winding of a slip - ring induction motor should be connected in star?

6.11 POST LAB VIVA QUESTIONS:

1. Explain the advantages and disadvantages of slip-ring induction motor.
2. What is the use of slip-rings in a slip-ring induction motor?
3. Is a slip-ring induction motor is a self start motor or not?
4. Draw the performance characteristics of a slip-ring induction motor.
5. What is the electrical equivalent of mechanical load in an induction motor?
6. What is the speed of an Induction motor for a) 4% slip b) 100% slip?

EXPERIMENT - 7

NO - LOAD & BLOCKED ROTOR TESTS ON THREE PHASE INDUCTION MOTOR

7.1 AIM

To perform No - load test on 3 - phase Induction motor and to find the magnetizing resistance and Reactance.

7.2 NAME PLATE DETAILS:

Motor

Voltage	
Current	
Rating	
Speed	
Phases	
Frequency	

7.3 APPARATUS:

S.No	Components	Type	Range	Quantity
1	3 pole MCB			
2	Ammeter			
3	Wattmeter			
4	Voltmeter			
5	Mechanical Load			

7.4 CIRCUIT DIAGRAM:

NO LOAD TEST:

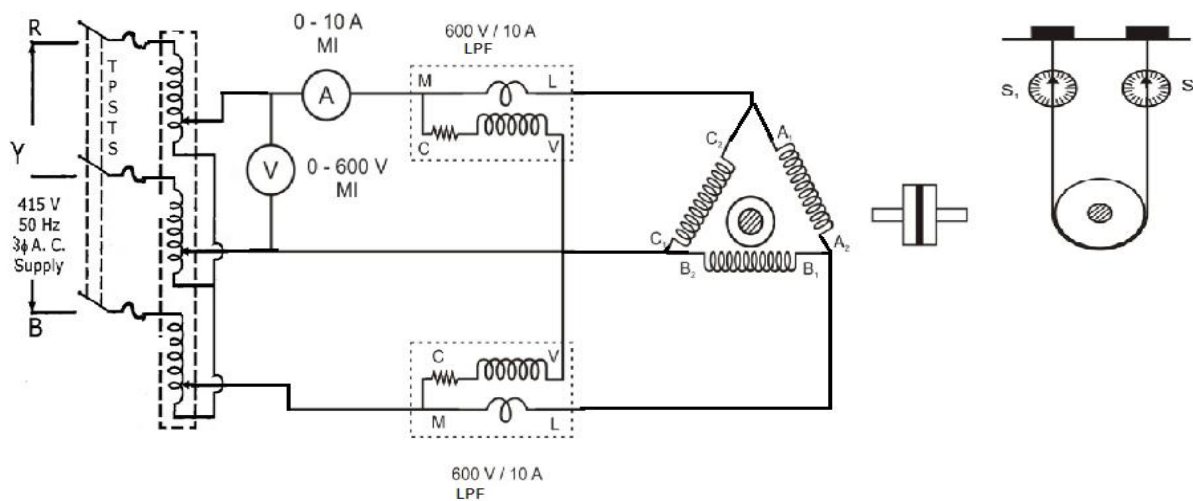

Fig – 7.1 No - Load Tests on Three Phase Induction Motor

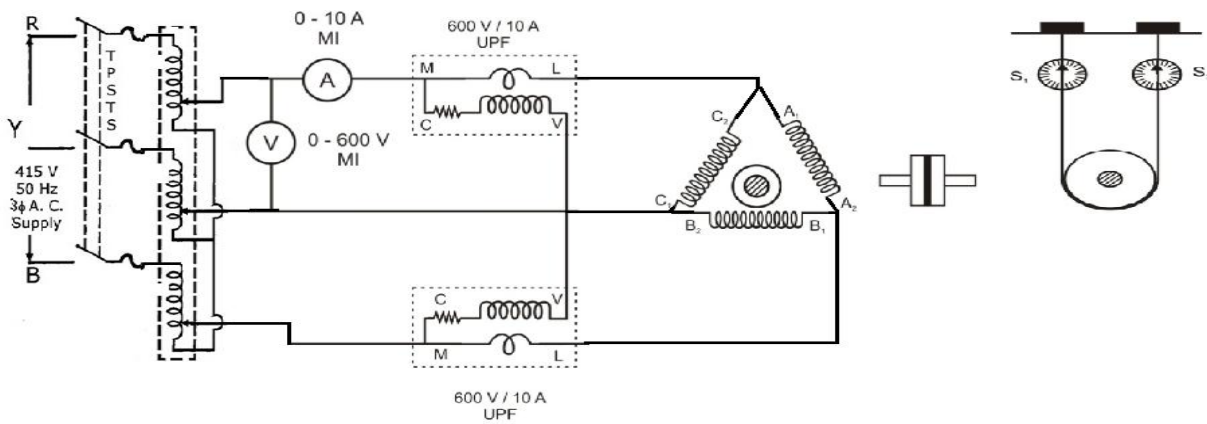

Fig – 7.2 Blocked Rotor Tests on Three Phase Induction Motor

7.5 PROCEDURE:

NO LOAD TEST:

1. Make the connections as per the circuit diagram.
2. Close the main switch and gradually increase the voltage applied to the stator through the auto transformer.
3. At rated voltage, take the values of the two watt meters (W_1 & W_2), stator current I_0 , Stator voltage

BLOCKED ROTOR TEST:

1. For the second figure Block the rotor and vary supply voltage until rated current flows through the circuit.
2. Note the readings of voltmeter, ammeter and wattmeters.
3. Tabulate the observations and calculate the power input and power factor for each reading.
4. Measure the stator resistance and make the necessary temperature correction.

7.6 CALCULATIONS:

The input Power = $W_1 + W_2 = P_0$

Stator copper loss = $3I_0^2 R_1$

We have no load input power $P_0 = \sqrt{3} V I_0 \cos\Phi_0$

$\cos\Phi_0 = P_0 / (\sqrt{3} V I_0)$

In phase component of load current = $I_0 \cos\Phi_0$

Magnetizing component of load current = $I_0 \sin\Phi_0$

Resistance in Magnetizing circuit = voltage per phase / $I_0 \cos\Phi_0$

Magnetizing reactance = voltage per phase / $I_0 \sin\Phi_0$

7.7 CIRCLE DIAGRAM PROCEDURE:

Tests Required

No-load Test

Run the induction motor on no-load at rated supply voltage. Observe the supply line voltage V_0 , No-load line current I_0 and no-load power P_0 .

$$\text{Phase angle for no load condition } \Phi_0 = \frac{P_0}{\sqrt{3V_0I_0}}$$

Blocked Rotor Test

Block the rotor firmly and apply a reduced voltage to obtain rated current at the motor terminals. Observe the supply line voltage V_{SC} , No-load line current I_{SC} and no-load power P_{sc} .

$$\text{Phase angle for blocked rotor condition } \Phi_{SC} = \frac{P_{sc}}{\sqrt{3V_{sc}I_{sc}}}$$

Current drawn if rated voltage is applied at blocked rotor condition $I_{SN} = I_{SC} \times \frac{V_0}{V_{sc}}$

Power input at rated voltage and motor in the blocked rotor condition $P_{SN} = P_{sc} \times \left(\frac{V_0}{V_{sc}}\right)^2$

Resistance Test:

By voltmeter-ammeter method determine per phase equivalent stator resistance, R_1 . If the machine is wound rotor type, find the equivalent rotor resistance R_2' also after measuring rotor resistance and required transformations are applied.

7.8 CONSTRUCTION OF CIRCLE DIAGRAM:

1. Draw horizontal axis OX and vertical axis OY. Here the vertical axis represents the voltage reference.
2. With suitable scale, draw phasor OA with length corresponding to I_0 at an angle Φ_0 from the vertical axis. Draw a horizontal line AB.
3. Draw OS equal to I_{SN} at an angle Φ_{SC} and join AS.
4. Draw the perpendicular bisector to AS to meet the horizontal line AB at C.
5. With C as centre, draw a semi circle passing through A and S. This forms the circle diagram which is the locus of the input current.
6. From point S, draw a vertical line SL to meet the line AB.
7. Fix the point K as below.

For wound rotor machines where equivalent rotor resistance R_2' can be found out:

Divide SL at point K so that SK: KL = equivalent rotor resistance: stator resistance.

For squirrel cage rotor machines: Find Stator copper loss using I_{SN} and stator winding resistance R_1 . Rotor copper loss = total copper loss – stator copper loss.

Divide SL at point K so that SK: KL = rotor copper loss: stator copper loss

Note: If data for separating stator copper loss and rotor copper loss is not available then assume that stator copper loss is equal to rotor copper loss. So divide SL at point K so that SK= KL

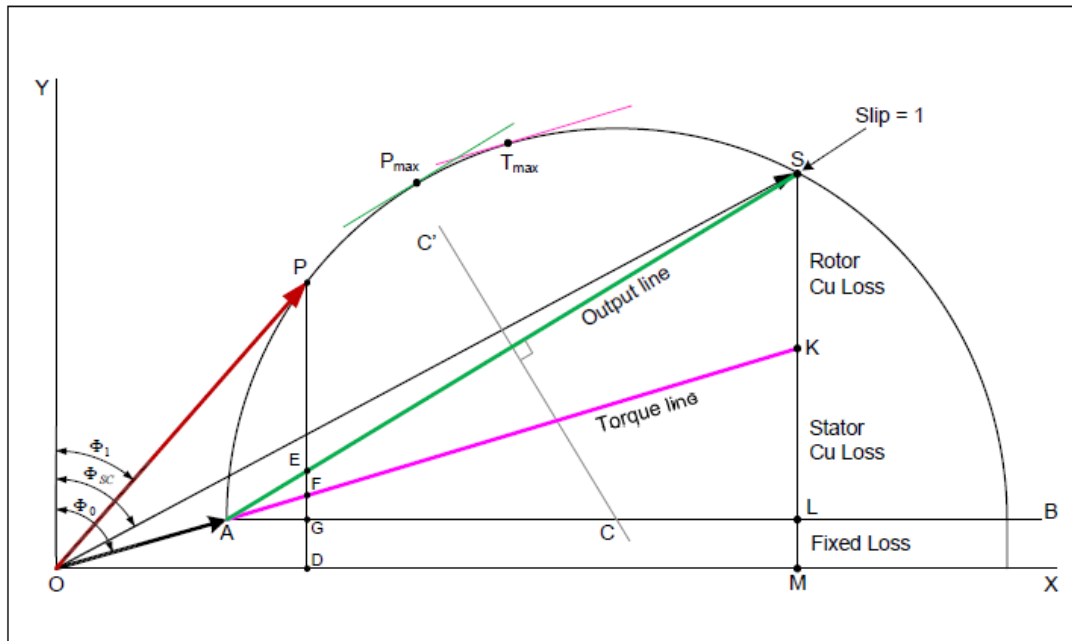

7.9 OBSERVATIONS:

No - Load test:

V (Vats)	I ₀ (ANPS)	W ₁ (Watts)	W ₂ (Watts)

Blocked rotor test:

V (Vats)	I (AMPS)	W ₁ (Watts)	W ₂ (Watts)

7.10 MODEL GRAPHS:

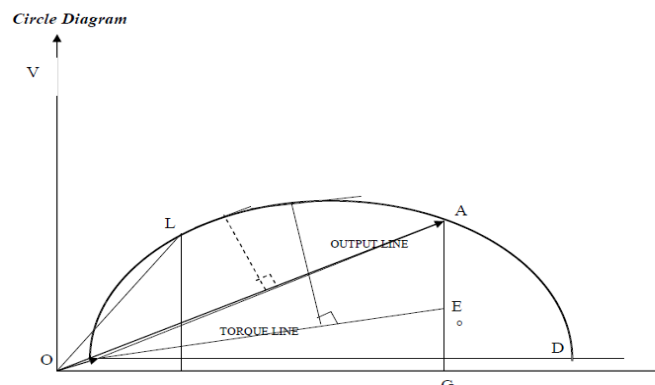

Fig – 7.3 Performance on Three Phase Induction Motor

7.11 PRECAUTIONS:

1. Loose connections are avoided.
2. Note down all meter readings without any parallax error.

7.12 RESULT:**7.13 PRE LAB VIVA QUESTIONS**

1. Explain what is meant by a 3 - phase induction motor.
2. Write the classification of 3 - phase induction motor.
3. State the steps to draw the equivalent circuit of 3 - phase induction motor.
4. State the condition for maximum torque of 3 - phase induction motor.

7.14 POST LAB VIVA QUESTIONS

1. Give the different methods of speed control of I.M.
2. How do you calculate slip speed?
3. State the condition when induction motor acts as induction generator.
4. Give the other name for induction generator

EXPERIMENT - 8

REGULATION OF 3- ϕ ALTERNATOR BY SYNCHRONOUS IMPEDANCE AND MMF METHODS

8.1 AIM:

To predetermine the regulation of an alternator by

- a) Synchronous impedance method and
- b) MMF method.

8.2 NAME PLATE DETAILS:

Motor

Voltage	
Current	
Output	
Speed	

Generator

Voltage	
Current	
Output	
Speed	

8.3 APPARATUS:

S.No	Item	Type	Range	Quantity
1	Ammeter			
2	Ammeter			
3	Voltmeter			
4	Rheostats			
5	Rheostats			

8.4 CIRCUIT DIAGRAM:

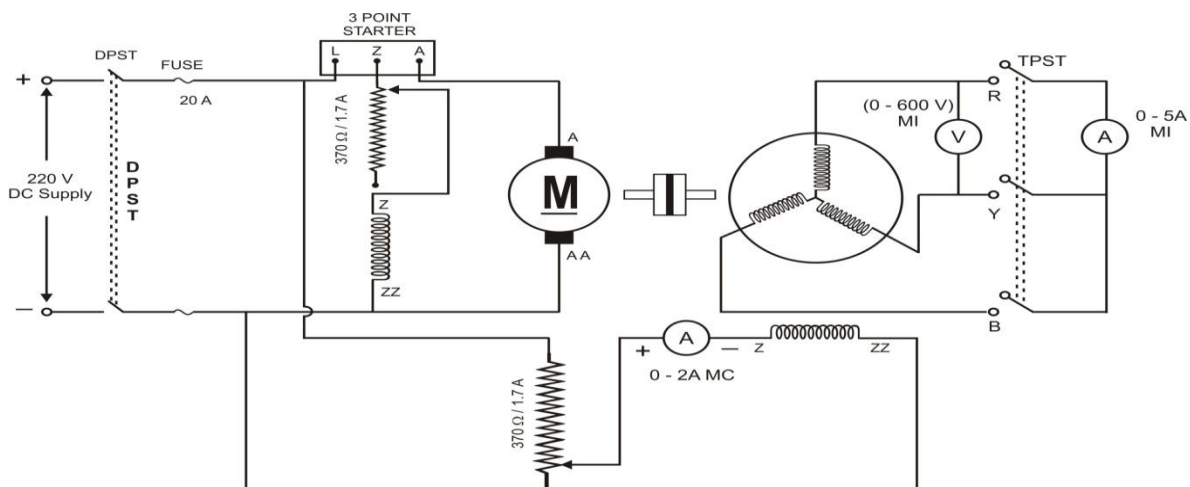

Fig – 8.1 Regulation of 3- ϕ Alternator Synchronous Impedance and MMF Methods

8.5 PROCEDURE:

1. Make the connections as per the circuit diagram. Start the alternator with the help of prime mover (DC Shunt motor) and adjust speed to the synchronous speed. The speed of the alternator is to be kept constant throughout the experiment.
2. Excite the field winding alternator keeping armature open.
3. Note down the terminal voltage at different values of field currents.
4. Draw the graph of armature voltage versus field current to get the open circuit characteristic (O.C.C) of the Alternator.
5. Close the TPST switch.
6. Excite the field winding of the alternator till the rated current flows through the armature.
7. Note down all meter readings.
8. Draw the graph of the short circuit current versus field current to get the short circuit characteristic (SCC).
9. Obtain the synchronous impedance corresponding to the rated voltage.

$$Z_s = \frac{V_{oc}}{I_{sc}}, I_f \text{ const}$$

10. Measure the armature resistance per phase by drop method. The a.c. resistance will be 20% more than the D.C. Resistance: $R_a = 1.2 R_{dc}$
11. Calculate the synchronous reactance, $X_s = \sqrt{Z_s^2 - R_a^2}$
12. Calculate the generated e.m.f. with full load at a power factor
13. $E = [(V \cos\phi + I R_a)^2 + (V \sin\phi + I X_s)^2]^{1/2}$
14. (+) sign for lagging power factor and (-) sign for leading power factors.
15. Calculate full load regulation at different power factors.
16. Draw the graph of regulation versus power factor

8.6 TABULAR COLUMN:

S.No	I_f	E_g	I_f	I_{sc}
1.				

8.7 PRECAUTIONS:

1. Loose connections are to be avoided.
2. Note down all meter readings without any parallax error.

8.8 RESULT:

8.9 PRE LAB VIVA QUESTIONS:

1. What is regulation of alternator?
2. Under what condition, regulation is positive or negative?
3. What is regulation at UPF

8.10 POST LAB VIVA QUESTIONS:

1. Why Regulation is so important in alternator?
2. How the regulation is effected by armature reaction?

EXPERIMENT - 9

SLIP TEST ON 3- ϕ SALIENT POLE SYNCHRONOUS MOTOR

9.1 AIM:

To conduct slip test and determine X_d and X_q of a salient-pole synchronous machine

9.2 NAME PLATE DETAILS:

DC MOTOR		SYNCHRONOUS MOTOR	
HP		HP	
Current		Voltage	
Voltage		Current	
Field voltage		Poles	
Field current		Frequency	

9.3 APPARATUS:

NAME	RANGE	TYPE	QUANTITY
Ammeter			
Ammeter			
Voltmeter			
Rheostat			
Tachometer			
3- ϕ VARIAC			

9.4 CIRCUIT DIAGRAM:

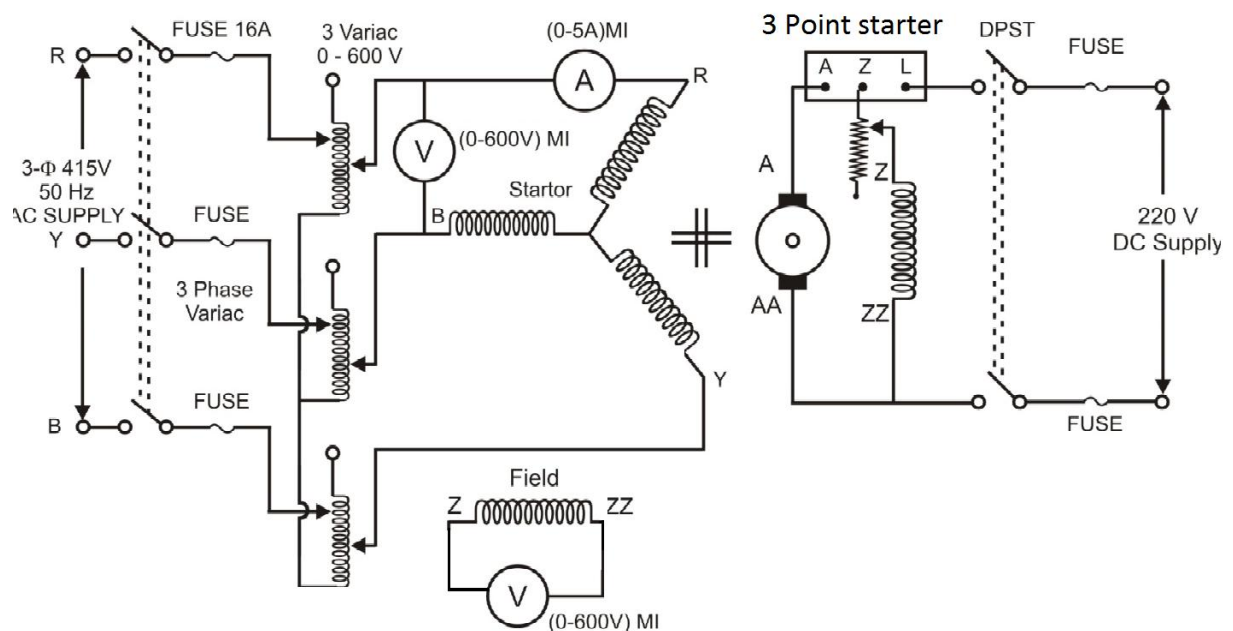

Fig – 9.1 X_d and X_q of a Salient Pole Synchronous Machine

9.5 PROCEDURE:

1. Make the connections as per the circuit diagram.
2. Run the alternator through the DC Motor at near synchronous speed, keeping the AC supply off.
3. Keeping the variac output voltage at minimum, connect the AC supply to the variac.
4. Note that the field winding is to be kept open throughout.
5. Increase the variac output voltage so that a reasonable current passes through the armature.
6. If the directions of rotation of the rotor and stator fields are the same, then a slight adjustment of speed causes significant oscillation of the armature current. Else reverse the direction of rotation of motor.
7. When the ammeter shows slow but wide oscillations note I_{\max} and I_{\min} and the corresponding voltages V_{\min} and V_{\max} and calculate X_d and X_q .
8. Using X_d and X_q , the regulation of the salient pole alternator at specified load condition can be determined using the appropriate phasor diagram.

9.6 CALCULATIONS:

$$X_d = \frac{\text{Maximum Volts per phase}}{\text{Maximum Current per phase}}$$

$$X_q = \frac{\text{Minimum Voltage per phase}}{\text{Minimum Current per phase}}$$

$$\tan \delta = \frac{I_a X_q \cos \phi - I_a R_a \sin \phi}{V + I_a R_a \cos \phi}$$

$$I_q = I_a \cos \psi$$

$$I_d = I_a \sin \psi$$

$$\psi = \phi + \delta$$

$$E_o = V \cos \delta + I_q R_a + I_d X_d$$

$$\% \text{ Regulation} = \frac{E_o - V}{V} \times 100$$

9.7 TABULAR COLUMN:

V(ph)_{min} (Volts)	V(ph)_{max} (Volts)	I_{min} (Amps)	I_{max} (Amps)	X_d (ohms)	X_q (ohms)

9.8 PRECAUTIONS:

1. DC motor field rheostat should be kept at minimum resistance position before starting.
2. Avoid parallax errors.

9.9 RESULT:

9.10 PRE LAB VIVA QUESTIONS:

1. Why ASA method is superior to ZPF method?
2. Why do you conduct Slip-test?
3. Describe voltage regulation of an alternator?
4. What is another name of Potier Triangle method?
5. What are the different methods used to find out the regulation. Compare them?

9.11 POST LAB VIVA QUESTIONS

1. What is the reaction theory and what is its significance?
2. How do you calculate Synchronous impedance using OCC and SC tests on a synchronous machine?
3. What is the use of Damper Windings?
4. What are the different methods of starting a synchronous motor?
5. The armature winding of an alternator is in star or delta or both?

EXPERIMENT - 10

V AND INVERTED V- CURVES OF 3 - ϕ SYNCHRONOUS MOTOR

10.1 AIM:

To draw the V and inverted V- curves of Synchronous motor.

10.2 NAME PLATE DETAILS:

DC MOTOR		SYNCHORONOUS MOTOR	
HP		HP	
Voltage		Voltage	
Current		Current	
Field voltage		Poles	
Field current		Frequency	

10.3 APPARATUS:

S. No	NAME	RANGE	TYPE	QUANTITY
1	Ammeter			
2	Ammeter			
3	Voltmeter			
4	Wattmeter			
5	Rheostat			
6	Load			

10.4 CIRCUIT DIAGRAM:

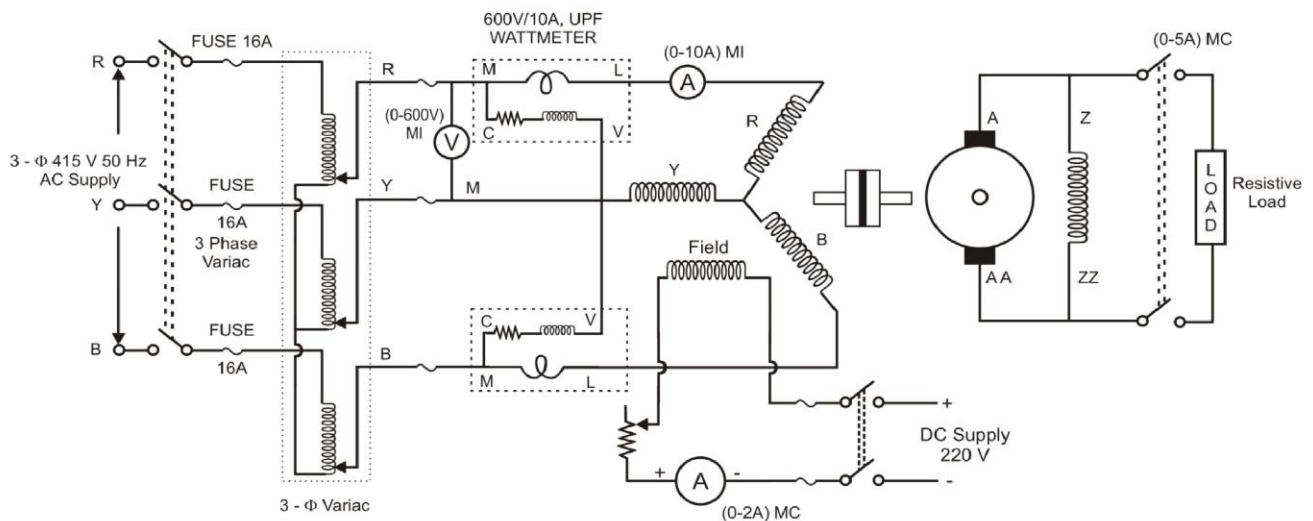

Fig – 10.1 V and Inverted V-Curves of 3- ϕ Synchronous motor

10.5 PROCEDURE:

1. Make the connections as per the circuit diagram.
2. Switch on the AC supply feeding to 3-phase synchronous motor and start the motor using 3- phase variac.
3. Ensure that the motor is running at no-load and synchronous Speed.
4. Now the field winding of the synchronous motor is excited with excitation unit.
5. Set the Rheostat of the field winding of the motor to the position of the normal excitation. (Here the armature current will draw the minimum current from the mains.)
6. Note down all meter readings at this position.
7. Decrease the excitation current in steps and note down ammeter and wattmeter readings. (Excitation current may be reduced till the rated armature current flows in the armature circuit of the synchronous motor) (I_f as I_a).
8. Again set back rheostat position to normal excitation position, now increase the excitation in steps and note down all meter readings.
9. Repeat the step - 5, 6, 7, and 8 for half load and full load.
10. Decrease the load on the motor and switch of the supply.

Note:

1. Keeping fixed load on the dc machine (DC Generator), the data for a V-curve is obtained by varying the field current and note down the armature current as suggested earlier. The V-curves are drawn for no load, Full load and one intermediate load.
2. For same data inverted V- curves are drawn between $\text{Cos}\phi$ (p.f) and I_f .

10.6 MODEL GRAPHS:

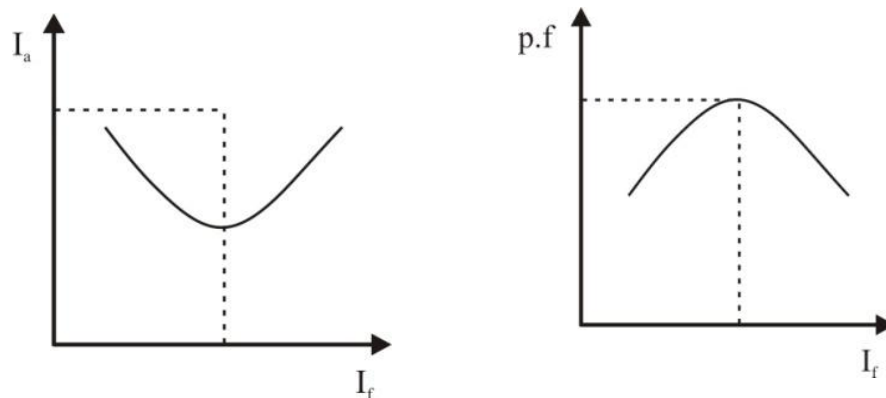

Fig – 10.2 V and Inverted V-Curves of 3- ϕ Synchronous Motor

10.7 TABULAR COLUMN:

At Full load

S.No	I_f (A)	I_a (A)	W (Watts)	Cos Φ
1				
2				

Half full load

S.No	I_f (A)	I_a (A)	W (Watts)	Cos Φ
1				
2				

At No Load

S.No	I_f (A)	I_a (A)	W (Watts)	Cos Φ
1				
2				

10.8 PRECAUTIONS:

1. Loose connections are avoided.
2. Note down all meter readings without any parallax error.
3. If the watt meter reading shows negative reading (Kick backs), then interchange the connection of **M** and **L** of the wattmeter.

10.9 RESULT:

10.10 PRE LAB VIVA QUESTIONS:

1. At what condition the power output of a synchronous generator connected to an infinite bus is maximum.
2. How can we run a synchronous motor as synchronous condenser?
3. Why Synchronous motor is not self-starting motor.
4. What happens if excitation is changed?
5. When load is increased on a synchronous motor, does the speed fall like an induction motor? If not, explain how the load torque is produced.

10.11 POST LAB VIVA QUESTIONS

1. When do we say an alternator is under floating condition during parallel operation?
2. What are the conditions required to synchronous an alternator with APSEB supply?
3. How can you increase the share of an alternator when it is connected to an infinite bus?
4. What are the different types of field constructions in Synchronous machines?
5. Draw 'V' and inverted 'V' curves of a synchronous motor.

EXPERIMENT - 11

NO-LOAD AND BLOCKED ROTOR TEST ON 1 - ϕ INDUCTION MOTOR

11.1 AIM:

To determine the parameters of equivalent circuit of a 1- ϕ induction motor by conducting no load test and blocked rotor test.

11.2 NAME PLATE DETAILS:

Motor

HP	
Voltage	
Current	
Output	
Speed	

11.3 APPARATUS:

NAME	RANGE	TYPE	QUANTITY
Ammeter			
Ammeter			
Voltmeter			
Voltmeter			

11.4 CIRCUIT DIAGRAM:

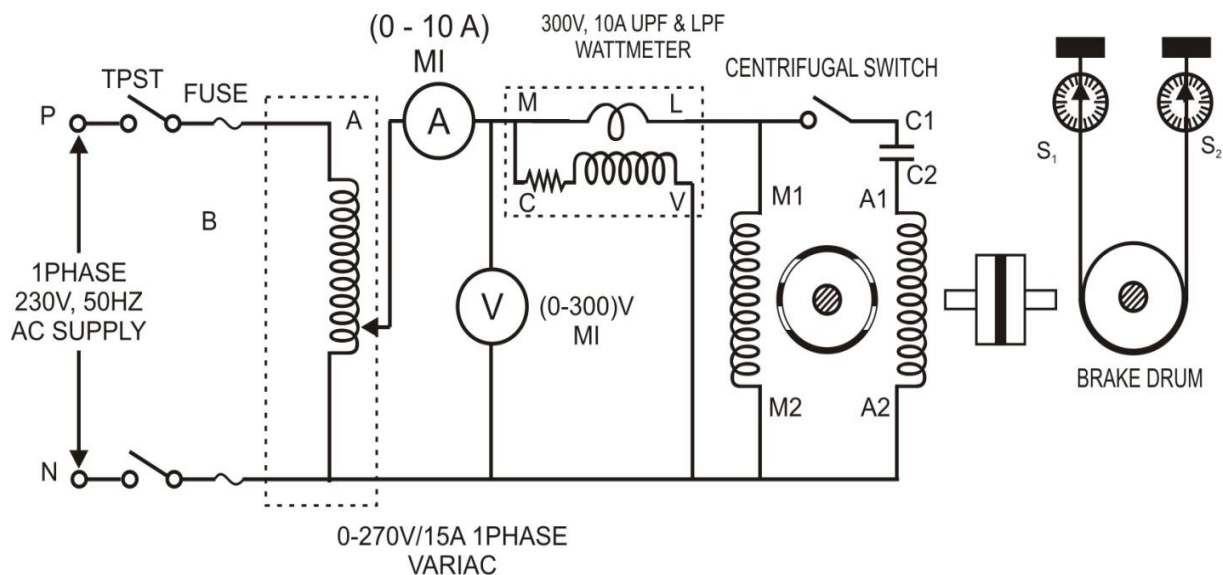

Fig – 11.1 Equivalent Circuit of a 1- ϕ Induction Motor

11.5 PROCEDURE:
NO - LOAD TEST

1. Connections are made as per the circuit diagram.
2. Apply the rated voltage to the induction motor by varying auto transformer, so that the machine runs at rated speed.
3. Note down the corresponding Ammeter, Voltmeter and Wattmeter readings.
4. Restore the autotransformer to its initial position, and switch off the supply.

BLOCKED ROTOR TEST:

1. Connections are made as per the circuit diagram
2. Block the rotor with the help of brake drum arrangement.
3. Vary the supply voltage with the help of autotransformer so that the ammeter reads rated current and note down the corresponding Ammeter, Voltmeter and Wattmeter readings.
4. Reduce voltage to zero with auto transformer and switch off the supply.

CALCULATIONS:

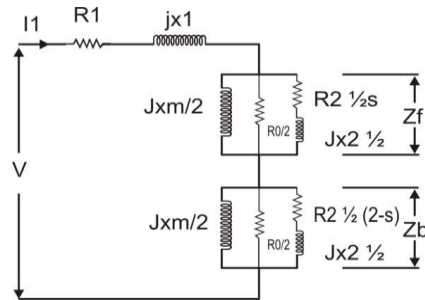

Fig – 11.2 Equivalent Circuit of 1-φ Induction Motor

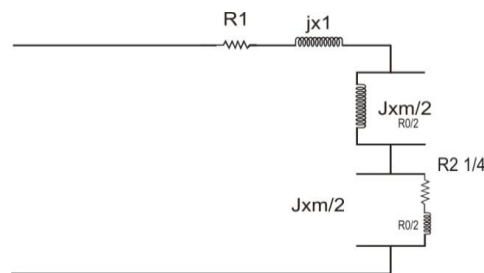

Fig – 11.3 Equivalent Circuit at No-Load Condition

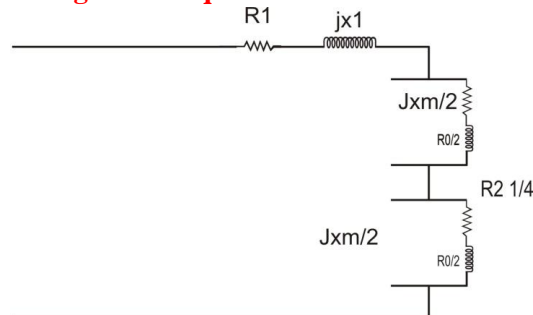

Fig- 11.4 Equivalent Circuit under Blocked Rotor Condition

11.5 TABULAR COLUMN:

BLOCKED ROTOR TEST

S.No	V _{sc} (Volts)	I _{sc} (amps)	W _{sc} (W)

NO LOAD TEST

S.No	V _o (Volts)	I _o (Amps)	W _o (W)

11.6 PRECAUTIONS:

1. While conducting the Block rotor test, never apply the full voltage. Gradually increase the voltage from zero till full load current Flows in the circuit.
2. While conducting the no load test, make sure that brake drum is Released fully.
3. Under blocked rotor test, auxiliary winding should be opened before the start of the blocked rotor test.

11.7 RESULT:

11.8 PRE LAB VIVA QUESTIONS:

1. How do you change the direction of rotation?
2. Why star point of the motor is not connected to neutral point of the supply?
3. Does the motor start when supply lines are connected?
4. Draw a two-phase supply waveform & leading current, lagging current with respect to the voltage.
5. Draw the 3-phase supply waveform & leading current, lagging current, with respect to the voltage.

11.9 POST LAB VIVA QUESTIONS

1. What is the advantage of star-delta starter when compared to D.O.L Starter?
2. For a 6-pole machine what is the value of synchronous speed?
3. Why slip cannot be zero in induction motor.
4. What are the two different types of rotors?

EXPERIMENT - 12

OPEN CIRCUIT AND SHORT CIRCUIT TESTS ON 1- ϕ TRANSFORMER

12.1 AIM:

To conduct the open and short circuit tests on a single phase transformer to determine core losses, copper losses, and hence determine regulation, efficiency and the parameters of the equivalent circuit using digital simulation.

12.2 APPARATUS:

S. No	Software	Desktop
1	Simscape power systems	1

12.3 CIRCUIT DIAGRAM:

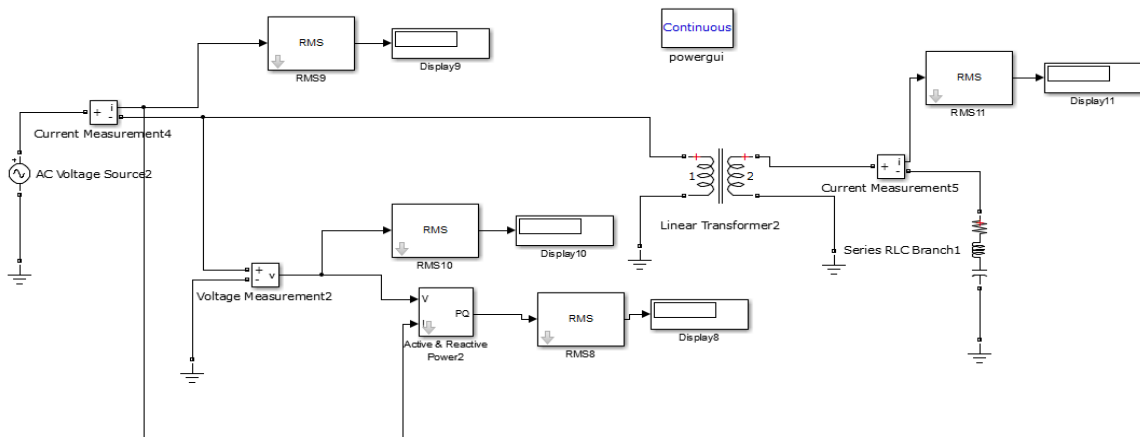

Fig – 12.1 OC and SC test of transformer

12.4 PROCEDURE:

1. Connect the circuit as per the figure using simscape power systems.
2. Note down the readings of ammeter and voltmeter and wattmeter under open circuit and short circuit condition.
3. Draw the performance and regulation characteristics of transformer.

12.5 CALCULATIONS:

Iron losses, $P_I = P_o$ watts.

$$\text{No load P.f., } \cos \phi_o = \frac{P_o}{VI_o}$$

$$\text{Magnetizing current, } I_m = I_o \sin \phi_o$$

$$\text{Loss component of no load current, } I_w = I_o \cos \phi_o$$

$$\text{Magnetizing reactance, } X_0 = \frac{V}{I_m}$$

$$\text{Equivalent resistance of iron losses, } R_0 = \frac{V}{I_m}$$

12.6 CALCULATIONS:

Full load copper losses $P_{Cu} = P_{SC}$ Watts.

$$\text{Power factor on short circuit, } \cos \phi_{oSC} = \frac{P_{sc}}{V_{sc} I_{sc}}$$

$$\text{Short circuit impedance } Z_{01} = \frac{V_{sc}}{I_{sc}} \Omega.$$

Referred to primary:

$$\text{HT equivalent resistance, } R_{01} = \frac{P_{sc}}{I_{sc}^2}.$$

$$\text{HT equivalent reactance, } X_{01} = \sqrt{Z_{01}^2 - R_{01}^2}$$

EFFICIENCY: At x times full load and power factor $\cos \phi$, output, $P_0 = x S \cos \phi$ kW where S is the KVA rating of the transformer.

1. INPUT = OUTPUT + IRON LOSS + $X^2 P_{Cu}$
2. Percent efficiency, $\eta = \text{OUTPUT} / \text{INPUT} \times 100$
3. Calculate the efficiency of the transformer at U. P. F. and 0.8 pf and 0.6 pf for $\frac{1}{4}$, $\frac{1}{2}$, $\frac{3}{4}$, 1 and $1 \frac{1}{4}$ full load and draw the characteristics.
4. Calculate the maximum efficiency and the load corresponding to maximum efficiency and compare the result obtained from graph.

REGULATION: Regulation is percent drop in voltage from no load to full load at any power factor due to voltage drops in resistance and leakage reactance of the transformer.

1. Calculate the percent resistance $V_R = I_1 R_1 / V_1 \times 100$ and percent reactance, $V_x = I_1 X_1 / V_1 \times 100$.
2. Calculate the percent regulation, $= V_r \cos \phi + V_x \sin \phi$ at different power factors viz: UPF, 0.8 pf lagg & lead 0.6 pf lagg & lead and draw the regulation curve.

12.8 EXPECTED CURVES:

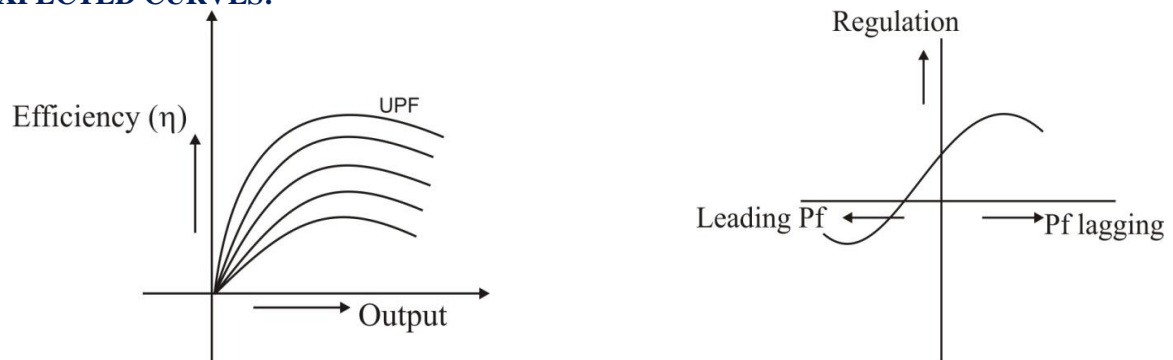

Fig – 12.2 Performance of the Single Phase Transformer

12.9 TABULAR COLUMN:

PART - I: Efficiency Curve

S. No.	x	P _o	P _i	η
1.				

PART - II: Regulation Curve at Full Load

S. No.	Power Factor	Regulation
1.		

12.10 PRECAUTIONS:

1. Loose connections are avoided.
2. Note down all meter readings without any parallax error.

12.11 RESULT:

12.12 PRE LAB VIVA QUESTIONS:

1. Which losses are called magnetic losses?
2. Write equations for hysteresis and eddy - current losses.
3. Why O.C test will conduct on LV side?
4. Why S.C test will conduct on HV side?
5. Why transformer fails to operate on D.C supply?
6. Explain why low power factor meter is used in O.C test.

12.13 POST LAB VIVA QUESTIONS

1. Why the iron losses are neglected when S.C test on a Transformer?
2. Draw the phasor diagram for a S.C. test on a transformer.
3. How do you reduce the hysteresis and eddy-current losses?
4. Under what condition the regulation of a transformer becomes zero?
5. Define voltage regulation with equation for lagging and leading loads.
6. Generally what is the efficiency percentage of a transformer?
7. What is the condition for maximum efficiency?

EXPERIMENT - 13

THREE PHASE TO TWO PHASE CONVERSION IN 1- ϕ TRANSFORMER USING DIGITAL SIMULATION

13.1 AIM:

Two transformers in Scott connection and verify that the relations between primary and secondary voltages and currents are as per the theoretical prediction.

13.2 APPARATUS:

S. No	Software	Desktop
1	Simscape power systems	1

13.3 CIRCUIT DIAGRAM:

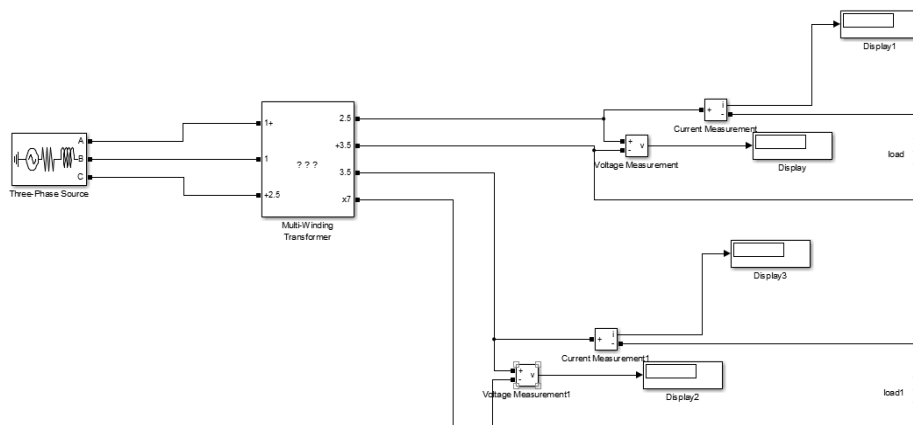

Fig – 13.1 Scott Connections of Transformers

13.4 PROCEDURE:

1. Connect the circuit as per the figure using simscape power systems.
2. Note down the readings of ammeter and voltmeter by varying R load in steps.

13.5 TABULAR COLUMN:

S.No	I_R (A)	I_Y (A)	I_B (A)	V_{RY} (V)	V_{YB} (V)	V_{TS} (V)	I_{TS} (A)	V_{MS} (V)	I_{MS} (A)
1.									
2.									
3.									
4.									
5.									

13.6 RESULT:

13.7 PRE LAB VIVA QUESTIONS:

1. What is the use of Scott connection?
2. Compare open delta, scott connections.
3. How the Scott connection is formed?
4. One transformer has cruciform type and second transformer has square type of core which is the better one?
5. Draw the phasor diagram for Scott connection.

13.8 POST LAB VIVA QUESTIONS:

1. Draw the phasor diagrams for leading and lagging loads.
2. For a step-down transformer which winding has low resistance?
3. What is the full name of C.R.G.O.S core material?
4. How 6 phase supply is produced? Where it is used?
5. What happens in tap changing in a transformer?
6. For which winding the tap changing is provided?

EXPERIMENT - 14

(A) SPEED CONTROL OF 3- ϕ SLIP RING INDUCTION MOTOR USING PLC

14.1 AIM:

To start and control speed of Induction motor using programmable logic controller

14.2 APPRATUS:

S. No.	Equipments	Range	QUANTITY
1	MCB2- for control circuit	25 A, 230 volts	1
2	MCB1- for power circuit	32 A, 415 volts	1
3	SMPS	2 A, 24 volts DC	2
4	Contactors	12 A, 240 volts coil voltage	
5	TPDT relays	230 volts, 5 A	
6	Thermal overload relay	10 A	
7	Selector switch for speed selection		
8	Relay board	2 A	11
9	Ammeter		1
10	Voltmeter		1
11	Connection terminals		-

14.3 CIRCUIT DIAGRAM:

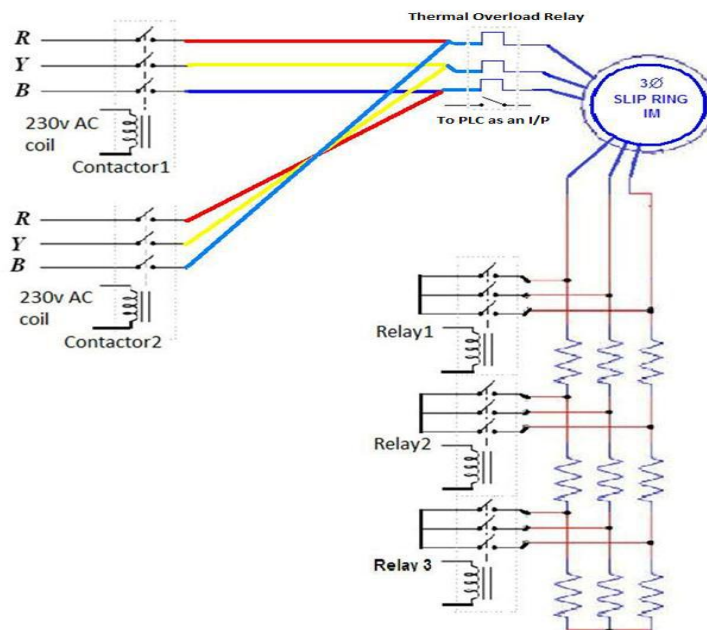

Fig – 14 (a). 1 Star Delta Starter

WORKING OF THE PROGRAM:

According to program written the motor will start with a delay of 10 seconds after pushing the input switch, as the motor starts exactly after 6 seconds from the time of starting the 1st relay will closed and the part of resistance gets shorted, after another 12 seconds the 2nd relay will be closed and after 18 seconds 3rd part of resistance will be closed and the total external resistance will be cut off. Then the motor runs with the rated speed till the red push button is pressed, when it is pushed the motor comes to halt and the relay gets opened. Exactly when blue push button is pressed the contactor which has been given the reverse supply phase sequence will get energized and the motor starts rotating in the anti-clockwise direction, as in case of the clockwise direction again the 1st relay will closed and the part of resistance gets shorted, after another 12 seconds the 2nd relay will be closed and after 18 seconds 3rd part of resistance will be closed and the total external resistance will be cut off.

14.4 PANEL BOARD:

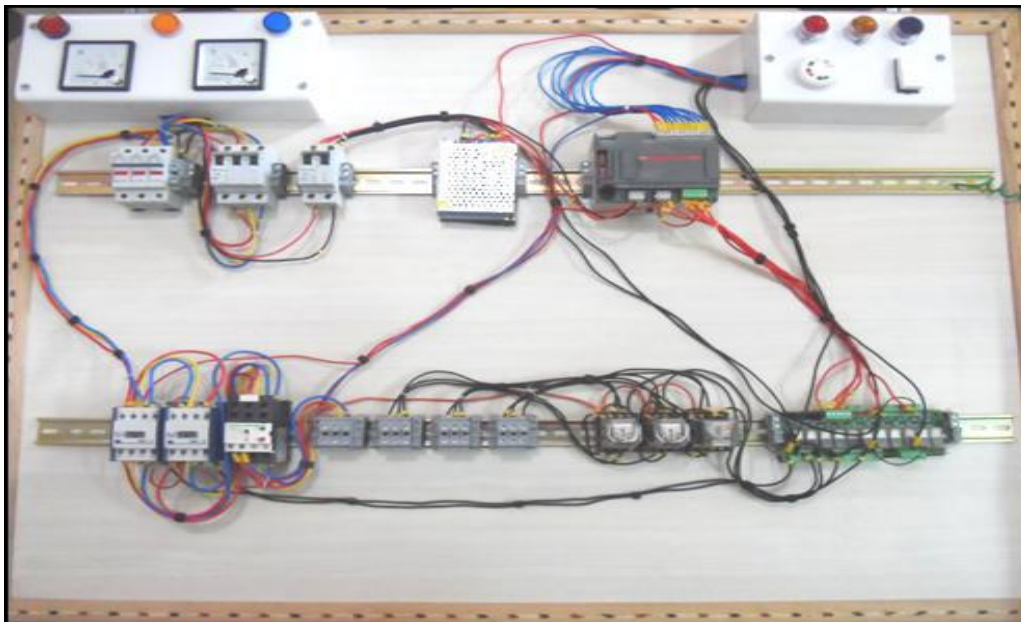

Fig – 14 (a). 2 Star Delta Starter Panel Board

14.5 ESTIMATED OUTCOME:

1. When the motor runs with full resistance in rotor circuit then the speed is observed on the tachometer as 1160 rpm in forward and 1170 rpm in reverse rotation.

2. The speed of induction motor will increase from 1160 rpm to 1212 rpm in forward rotation and 1170 rpm to 1222 rpm in reverse rotation when the first resistance in rotor circuit is cut off.
3. The speed increases from 1212 rpm to 1296 rpm in forward rotation and 1222 rpm to 1346 rpm in reverse rotation when second resistance is cut off.
4. The motor gains rated speed of 1488 rpm when all the resistances are cut off.

14.6 RESULT:

14.7 PRE LAB VIVA QUESTIONS:

1. How do you connect the six terminals of the motor as delta or Star?
2. What are the different starting methods used to start induction motors?
3. What is the role of a rotating flux?
4. What is the difference between squirrel cage induction motor and slip ring induction motor?
5. Why the rotor winding of a slip - ring induction motor should be connected in star?

14.8 POST LAB VIVA QUESTIONS:

1. Explain the advantages and disadvantages of slip-ring induction motor.
2. What is the use of slip-rings in a slip-ring induction motor?
3. Is a slip-ring induction motor a self start motor or not?
4. Draw the performance characteristics of a slip-ring induction motor.
5. What is the electrical equivalent of mechanical load in an induction motor?
6. What is the speed of an Induction motor for a) 4% slip b) 100% slip?

14 (B) STAR - DELTA STARTER USING PLC

14.1 AIM:

Three phase squirrel cage induction motor starting with Star-Delta starter by using PLC

14.2 APPARATUS:

S. No.	Equipments	RANGE/TYPE	QUANTITY
1	AUXILARY CONTACTORS	240V,50HZ	1
2	MAIN CONTACTORS	240V,50HZ	1
3	POLE CONTACTORS	240V,50HZ	1
4	DELTA CONTACTORS	240V,50HZ	1
5	SMPS	220/24V DC, 1A	1
6	PUSH BUTTONS	-	2
7	MCB	240V/32A	1
8	PLC TRAINER KIT	DVP	1

14.3 CIRCUIT DIAGRAM:

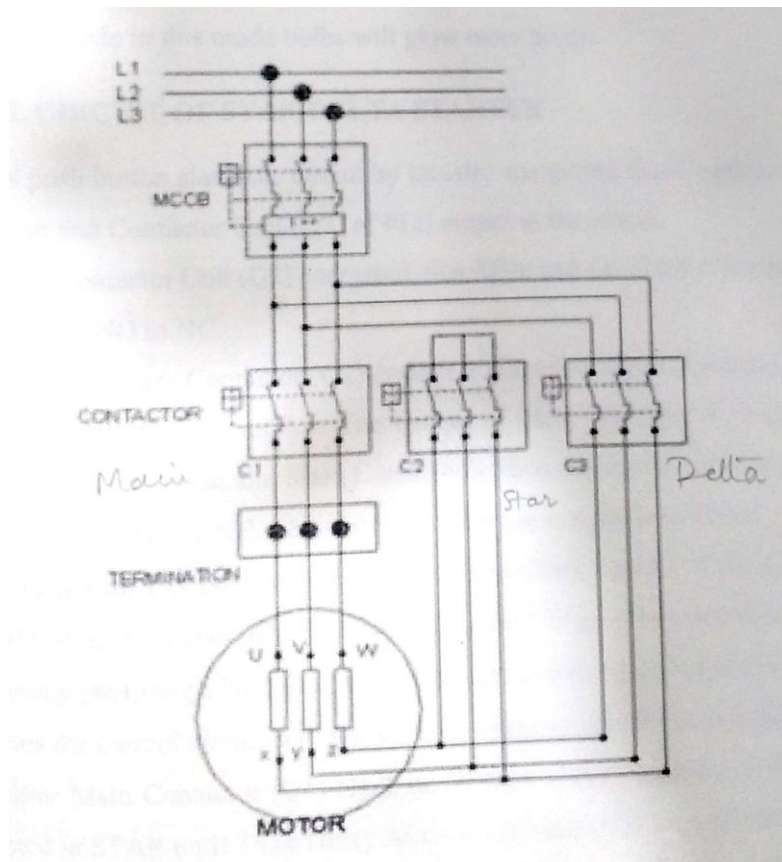

Fig – 14 (a). 1 Star Delta Starter

14.4 PROCEDURE:

1. Connect the 24 V DC SMPS to the three phase supply unit. Connect a multimeter to measure the line current.
2. Connect the contactors to the stator windings of the induction motor. The windings connections can be [plugged to the connection box on the induction motor. The stator must be WYE connected.
3. Connect the tachogenerator to the breaker control unit.
4. Make sure that the torque knob in the brake unit is at minimum, i.e., rotate all the way to the CCW direction.
5. Connect the NO and NC switches to the digital input module of the PLC. For each switch, connect one end to 24V of SMPS, and connect other end to the corresponding input sockets on PLC basic unit.
6. Connect PLC output from the PLC basic unit to the contactor outputs of three contactors are Y0,Y1,Y2. Connect A2- end of main contractor to zero volt on SMPS.
7. Open the STEP 7 software to program the PLC.
8. Make a online connection between the PLC and the software by running the command from “File/Connect online”
9. Create a new project. Then, in “Program/OBI” write your code in FBD/LD or STL.
10. Right click on OBI and choose “Download to CPU” command.
11. When file transfer is finished, switch PLC to RUN mode.

14.5 LADDER LOGIC PROGRAM FOR STAR DELTA STARTER USING PLC:

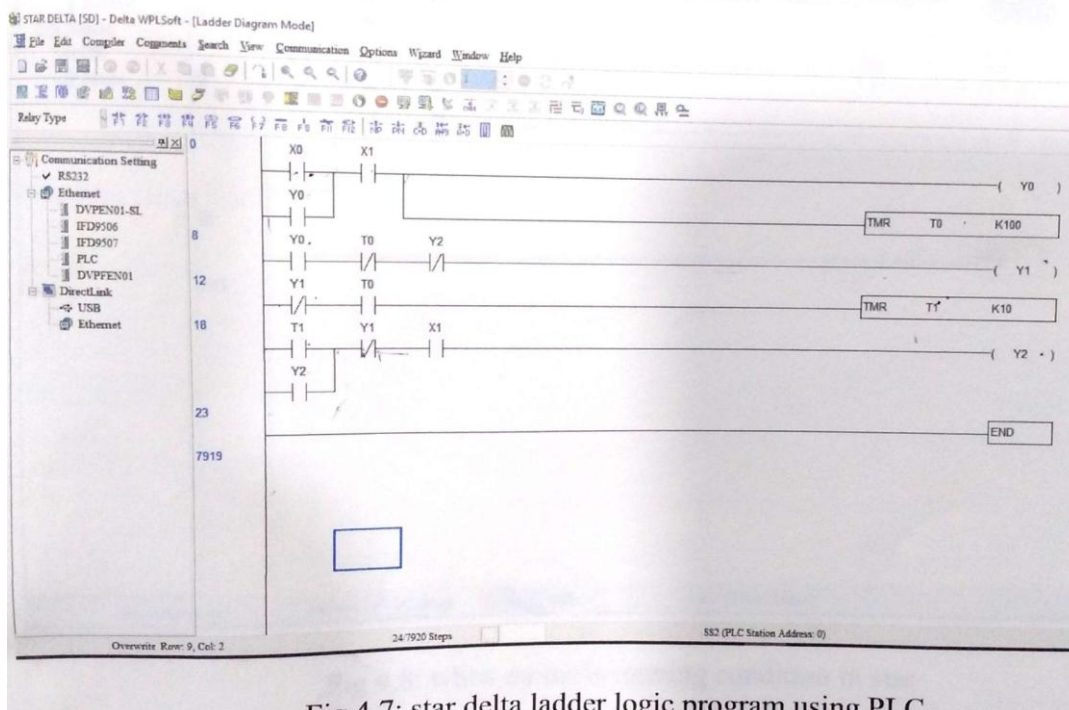
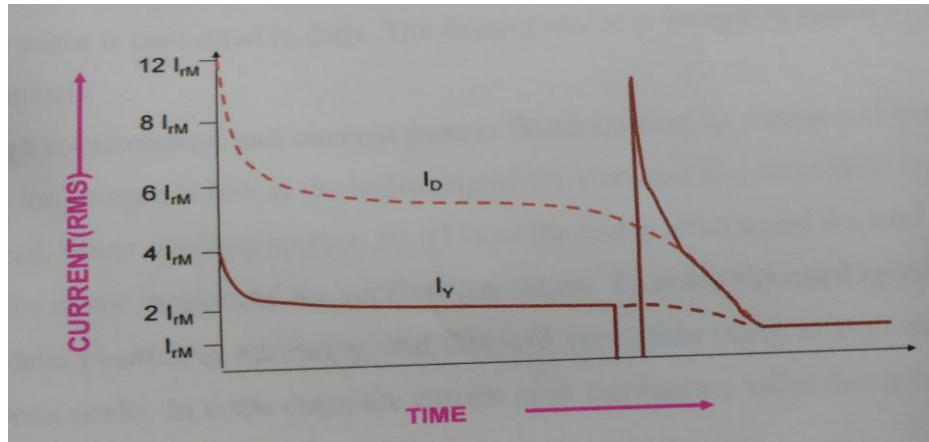

Fig 4.7: star delta ladder logic program using PLC

14.6 MOTOR STARTING CHARACTERISTICS OF STAR – DELTA STARTER:



14.7 RESULT:

14.7 PRE LAB VIVA QUESTIONS:

1. Advantages of star delta starter?
2. Different type of starters for three phase induction motors?

14.8 POST LAB VIVA QUESTIONS:

1. Disadvantages of star delta starter?
2. Comment on current characteristics.