

# **THEORY OF MACHINES LABORATORY**

## **LAB MANUAL**

**Year : 2019- 2020**  
**Course Code : AME111**  
**Regulation : IARE-R16**  
**Class : VI Semester**  
**Branch : ME**



**Department of Mechanical Engineering**

**INSTITUTE OF AERONAUTICAL ENGINEERING**

**(Autonomous)**

**Dundigal – 500 043, Hyderabad**



# INSTITUTE OF AERONAUTICAL ENGINEERING

(Autonomous)

Dundigal, Hyderabad - 500 043

## MECHANICAL ENGINEERING

<b>Program Outcomes</b>	
<b>PO1</b>	<b>Engineering knowledge:</b> Apply the knowledge of mathematics, science, engineering fundamentals, and an engineering specialization to the solution of complex engineering problems.
<b>PO2</b>	<b>Problem analysis:</b> Identify, formulate, review research literature, and analyze complex engineering problems reaching substantiated conclusions using first principles of mathematics, natural sciences, and engineering sciences.
<b>PO3</b>	<b>Design/development of solutions:</b> Design solutions for complex engineering problems and design system components or processes that meet the specified needs with appropriate consideration for the public health and safety, and the cultural, societal, and environmental considerations.
<b>PO4</b>	<b>Conduct investigations of complex problems:</b> Use research-based knowledge and research methods including design of experiments, analysis and interpretation of data, and synthesis of the information to provide valid conclusions.
<b>PO5</b>	<b>Modern tool usage:</b> Create, select, and apply appropriate techniques, resources, and modern engineering and IT tools including prediction and modeling to complex engineering activities with an understanding of the limitations.
<b>PO6</b>	<b>The engineer and society:</b> Apply reasoning informed by the contextual knowledge to assess societal, health, safety, legal and cultural issues and the consequent responsibilities relevant to the professional engineering practice.
<b>PO7</b>	<b>Environment and sustainability:</b> Understand the impact of the professional engineering solutions in societal and environmental contexts, and demonstrate the knowledge of, and need for sustainable development.
<b>PO8</b>	<b>Ethics:</b> Apply ethical principles and commit to professional ethics and responsibilities and norms of the engineering practice.
<b>PO9</b>	<b>Individual and team work:</b> Function effectively as an individual, and as a member or leader in diverse teams, and in multidisciplinary settings.
<b>PO10</b>	<b>Communication:</b> Communicate effectively on complex engineering activities with the engineering community and with society at large, such as, being able to comprehend and write effective reports and design documentation, make effective presentations, and give and receive clear instructions.
<b>PO11</b>	<b>Project management and finance:</b> Demonstrate knowledge and understanding of the engineering and management principles and apply these to one's own work, as a member and leader in a team, to manage projects and in multidisciplinary environments.
<b>PO12</b>	<b>Life-long learning:</b> Recognize the need for, and have the preparation and ability to engage in independent and life-long learning in the broadest context of technological change.
<b>Program Specific Outcomes</b>	
<b>PSO1</b>	<b>Professional skills:</b> To produce engineering professional capable of synthesizing and analyzing mechanical system including allied engineering streams.
<b>PSO2</b>	<b>Modelling and Simulation Practices:</b> An ability to adapt and integrate current technologies in the design and manufacturing domain to enhance the employability.
<b>PSO3</b>	<b>Successful career and entrepreneurship:</b> To build the nation by imparting technological inputs and managerial skills to become Technocrats.

## INDEX

<b>S. No.</b>	<b>List of Experiments</b>	<b>Page No.</b>
1	To study the function of a Governor.	7
2	To determine the Gyroscope couple.	11
3	To draw free body diagram and determine forces under static condition.	15
4	To draw free body diagram and determine forces under dynamic condition.	19
5	To determine balancing forces and reciprocating masses.	23
6	To determine the Ball bearing life.	25
7	To determine the longitudinal and transverse vibration.	31
8	To determine critical speed of a shaft.	35
9	To study the various mechanism and their inversions.	41
10	To study an automobile differential gear box.	47
11	To study Vibrations in beam Structures.	62

## ATTAINMENT OF PROGRAM OUTCOMES & PROGRAM SPECIFIC OUTCOMES

<b>Exp. No.</b>	<b>Experiment</b>	<b>Program Outcomes Attained</b>	<b>Program Specific Outcomes Attained</b>
1	To study the function of a Governor	PO1	PSO1
2	To determine the Gyroscope couple.	PO1, PO3	PSO1
3	To draw free body diagram and determine forces under static condition.	PO1, PO3	PSO1
4	To draw free body diagram and determine forces under dynamic condition.	PO1, PO2, PO4	PSO1
5	To determine balancing forces and reciprocating masses.	PO1, PO3	PSO1
6	To determine the bearing life.	PO1, PO2, PO4	PSO1
7	To determine the longitudinal and transfer vibration.	PO1, PO2, PO3	PSO1
8	To determine critical speed of a shaft.	PO1, PO2, PO3	PSO1
9	To design various mechanism and their Inversions	PO1, PO2	PSO1
10	To study automobile differential gear box.	PO1, PO3	PSO1
11	To study Vibrations in beam Structures	PO1, PO3	PSO1

# **EXPERIMENT NO. 1**

## **UNIVERSAL GOVERNOR**

### **AIM:**

- Determination of characteristics curve of sleeve portion against controlling force and speed.
- Potting of characteristic curves of rotation.

### **APPARATUS:**

- Watt Governor Arrangement

### **INTRODUCTION & DESCRIPTION:**

The drive unit consists of a small electric motor. The optional governor mechanics can be mounted on spindle. Precise speed control is afforded by the dimmer-stat. A counter bolt is provided to measure the speed with tachometer (not in our scope of supply). A graduated scale is fixed to the bracket and guided in vertical direction.

The center sleeve of the Porter and Proell governor incorporates a weight sleeve to which weights can be added. The Hartnell governor provides means of varying spring rate and initial compression level and mass of rotating weight. This enables the Hartnell Governor to be operated as a stable or unstable governor.

The apparatus is designed to exhibit the characteristics of the spring-loaded governor and dead weight governor.

A D. C. Motor drives the apparatus. The DC Motor is mounted on a steel base. The apparatus can perform following experiments,

- 1) Watt, 2) Porter, 3) Proell, 4) Hartnell type.

### **SPECIFICATION:**

Drive: D. C. Motor,  $\frac{1}{2}$  HP. 1500 RPM. Speed variation arrangement provided. Separate linkages for governor arrangements mentioned above are provided using same motor and base. Speed measurement is to be done by hand tachometer, (Not provided with unit) sleeve displacement is to be noted on scale provided. Variable speed control unit i. e. dimmer is provided with the apparatus. Following experiments can be conducted on the Gravity controlled governor apparatus i. e. for Watt Governor, Porter Governor and Proell Governor and also on spring loaded governor.

- 1) Obtaining the Graph of Governor speed V/S sleeve displacement.
- 2) Containing the governor characteristics i. e. the graph of controlling force v/s radius of rotation of the ball center.

## UTILITIES REQUIRED:

Electricity Supply: Single Phase, 220V AC, 50 Hz, 5-15Amp socket with earth connection.

## EXPERIMENTAL PROCEDURE:

The control unit is switched on and the speed control slowly rotated, increasing the governor speed until the center sleeve rises off the lower stop and aligns with the first division on the graduated scale. The sleeve position and speed are then recorded. Speed may be determined using hand tachometer on the spindle. The governor speed is then increased in steps to give suitable sleeve movements, and readings repeated at each stage throughout the range of sleeve movement possible.

The result may be plotted as curves of speed against sleeve position. Further tests are carried out changing the value of one variable at a time to produce a family of curves.

## OPERATING INSTRUCTIONS:

For obtaining the graphs as mentioned above following instructions may be followed.

- 1) Arrange the set up as a Watt/ Porter, Proell Governor. This can be done by removing the upper sleeves on the vertical spindle of the governor and using proper linkages provided shows in fig.
- 2) Make proper connections of the motor.
- 3) Increase the motor speed slowly and gradually.
- 4) Note the speed by tachometer and sleeve displacement on the scale provided.
- 5) Plot the graph of speed v/s sleeve displacement for watt, Porter, Proell governor.
- 6) Plot the graph of speed v/s governor height for Watt governor.
- 7) Plot the governor characteristic after doing the necessary calculations.

## DIMENSIONS:

- a) Length of each link  $l =$  cm.
- b) Initial height of governor  $h_0 =$  cm.
- c) Initial radius of rotation  $r_0 =$  cm.
- d) Weight of each ball assembly  $w =$  Kg.

Go on increasing the speed gradually and take the readings for speed of rotation „N“ and corresponding sleeve displacement „X“ radius of rotation „r“ at any position could be found as follows –

- i) Find height  $h = h_0 - X/2$
- ii) Find „ $\alpha$ “ by using  $\text{Cos } \alpha = h / l$
- iii) Then  $r = 50\text{mm} + l \cdot \text{Sin } \alpha$

**OBSERVATION TABLE:**

Sr. No .	Governor Speed N	Angular velocity $\omega = 2\pi N / 60$	Sleeve displacement (X)	Height (h)	$\cos \alpha = h / l$	Radius of rotation (r)	Force $F = w \omega^2 r / g$ (Kg)

Following graphs may than be plotted to study governor characteristics

- 1) Force v / s radius of rotation.
- 2) Speed v / s Sleeve displacement.

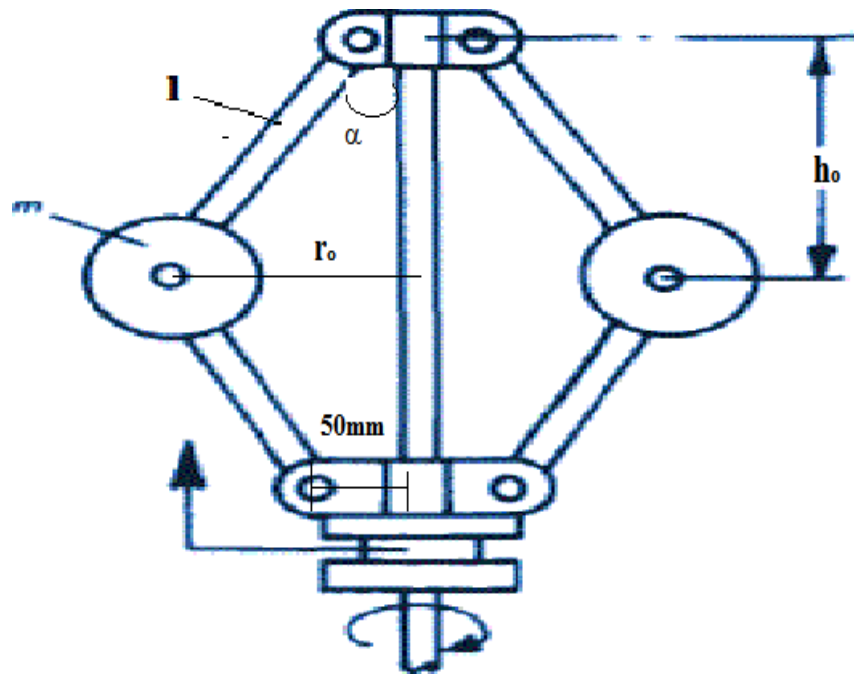

FIG: WATT GOVERNOR

**PRECAUTIONS:**

- 1) Do not keep the mains “ON” when trial is complete.
- 2) Increase the speed gradually.
- 3) Take the sleeve displacement reading when the pointer remains steady.
- 4) See that at higher speed the load on sleeve does not hit the upper sleeve of the governor.
- 5) While closing the test bring the dimmer to zero position and then switch “OFF” the motor.

**RESULT:****VIVA – QUESTIONS:**

- 1) What is the function of a governor? How does it differ from that of a flywheel?
- 2) State the different types of governors. What is the difference between centrifugal and inertia type governors?
- 3) Explain the term height of the governor. What are the limitations of a Watt governor?
- 4) What is the stability of a governor?
- 5) Define the Sensitiveness of governor.
- 6) Which of the governor is used to drive a gramophone?



## **EXPERIMENT NO. 2**

### **GYROSCOPE**

#### **AIM:**

- To study the gyroscopic effect of a rotating disc.

#### **APPARATUS:**

- Gyroscopic test rig
- Stop watch
- Tachometer

#### **THEORY:**

- Experimental justification of the equation  $T = I\omega\omega_p$   
couple by observation and measurement of results for independent variation  
in applied couple  $T$  and precession  $\omega_p$ .

#### **INTRODUCTION:**

##### **AXIS OF SPIN:**

If a body is revolving about an axis, the latter is known as axis of spin (Refer Fig.1, where OX is the axis of spin).

##### **PRECESSION:**

Precession means the rotation about the third axis OZ (Refer Fig. 1) that is perpendicular to both the axis of spin OX and that of couple OY.

##### **AXIS OF PRECESSION:**

The third axis OZ is perpendicular to both the axis of spin OX and that of couple OY is known as axis of precession.

##### **GYROSCOPIC EFFECT:**

To a body revolving (or spinning) about an axis say OX, (Refer Fig.1) if a couple represented by a vector OY perpendicular to OX is applied, then the body tries to process about an axis OZ which is perpendicular both to OX and OY. Thus, the couple is mutually perpendicular.

The above combined effect is known as processional or gyroscopic effect.

## **GYROSCOPE:**

It is a body while spinning about an axis is free to rotate in other directions under the action of external forces.

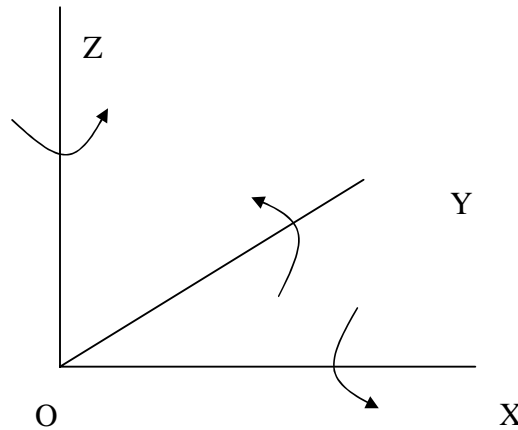

OX – Axis of spin, OY – Axis of Couple, OZ – Axis of Precession

Figure 1

## **THEORY:**

### **DESCRIPTION:**

The set up consists of heavy disc mounted on a horizontal shaft, rotated by a variable speed motor. The rotor shaft is coupled to a motor mounted on a trunnion frame having bearings in a yoke frame, which is free to rotate about vertical axis. A weight pan on other side of disc balances the weight of motor. Rotor disc can be move about three axis. Weight can be applied at a particular distance from the center of rotor to calculate the applied torque. The gyroscopic couple can be determined with the help of moment of inertia, angular speed of disc and angular speed of precession.

### **UTILITIES REQUIRED:**

Electricity Supply: Single Phase, 220 V AC, 50 Hz 5-15 amp socket with earth connection, Tachometer, Bench Area Required: 1 m x 1 m.

### **EXPERIMENTAL PROCEDURE:**

1. Set the rotor at zero position.
2. Start the motor with the help of rotary switch.

3. Increase the speed of rotor with dimmer stat & stable it & measure the R.P.M. with the help of tachometer.
4. Put the weight on weight pan then yoke rotate at anticlockwise direction.
5. Measure the rotating angle (30o, 40o) with the help of stopwatch.
6. Repeat the experiment for the various speeds and loads.
7. After the test is over set dimmer stat to zero position and switch off main supply.

**OBSERVATION & CALCULATION:**

DATA:

$$g = 9.81 \text{ m/sec}^2$$

$$r = \dots\dots\text{m}$$

$$W = \dots\dots\text{kg}$$

$$L = \dots\dots\text{m}$$

**OBSERVATION TABLE:**

S. No.	N (RPM)	w (kg)	dθ (degree)	dt (sec)
1.				
2.				
3.				

**CALCULATIONS:**

$$T_{the} = I \omega \alpha \text{ kg-m} = \dots\dots\dots$$

$$I = \frac{W}{g} \times \frac{r^2}{2} \text{ , kg-m-sec}^2 = \dots\dots\dots$$

$$\omega = \frac{2 \times \pi \times N}{60} \text{ , rad/sec} = \dots\dots\dots$$

$$\omega = \frac{d\theta}{dt} \times \frac{\pi}{180} \text{ rad/sec} = \dots\dots\dots$$

$$T_{act} = wL \text{ kg m, kg-m} = \dots\dots\dots$$

## **NOMENCLATURE:**

$d\theta$	=	Angle of precession
$dt$	=	Time required for this precessions, sec
$g$	=	Acceleration due to gravity, $m/sec^2$
$I$	=	Moment of inertia of disc, $kg\ m\ sec^2$
$L$	=	Distance of weight for the center of disc, m
$N$	=	RPM of Disc spin.
$r$	=	Radius of disc, m
$T_{the}$	=	Theoretical Gyroscopic couple, kg-m
$T_{act}$	=	Actual Gyroscopic couple, kg-m
$W$	=	Weight of rotor disc, kg
$w$	=	Weight on pan, kg
$\omega$	=	Angular velocity of disc, rad/sec
$\omega_p$	=	Angular velocity of precession of yoke about vertical axis,

## **RESULT:**

### **VIVA – QUESTIONS:**

- 1) Write a short note on gyroscope.
- 2) What do you understand by gyroscopic couple? Derive a formula for its magnitude.
- 3) Explain the application of gyroscopic principles to aircrafts.
- 4) Discuss the effect of the gyroscopic couple on a two wheeled vehicle when taking a turn.
- 5) When the pitching of a ship is upward, the effect of gyroscopic couple acting on it will be to move the ship towards port side or to move the ship towards star-board.

## **EXPERIMENT NO. 3**

### **STATIC FORCE ANALYSIS**

#### **AIM:**

- To balance the masses statically of a simple rotating mass system and to observe the effect of unbalance in a rotating mass system.

#### **APPARATUS:**

- Rotating mass balance system.

#### **THEORY:**

- **CONDITIONS FOR STATIC BALANCING:**

If a shaft carries a number of unbalanced masses such that the center of mass of the system lies on the axis of rotation, the system is said to statically balance.

- **BALANCING OF SEVERAL MASSES ROTATING IN DIFFERENT PLANES:**

When several masses revolve in different planes, they may be transferred to a reference plane (written as RP), which may be defined as the plane passing through a point on the axis of rotation and perpendicular to it. The effect of transferring a revolving mass (in one plane) to a reference plane is to cause a force of magnitude equal to centrifugal force of the revolving mass to act in the reference plane, together with a couple of magnitude equal to the product of the force and the distance between the plane of rotation and the reference plane. In order to have a complete balance of the several revolving masses in different planes, the following conditions must be satisfied:

1. The forces in the reference plane must balance, i.e. the resultant force must be zero.
2. The couple about the reference plane must balance, i.e. the resultant couple must be zero.

Let us now consider four masses  $m_1$ ,  $m_2$ ,  $m_3$  and  $m_4$  revolving in planes 1, 2, 3 and 4 shown in fig. The relative angular positions of these masses are shown in the end view

Fig. The magnitude, angular position and position of the balancing mass  $m_1$  in plane 1 may be obtained as discussed below:

1. Take one of the planes, say 1 as the reference plane (R.P.). The distance of all the other planes to the left of the reference plane may be regarded as negative, and those to the right as positive.
2. Tabulate the data as in table. The planes are tabulated in the same order i.e. 1, 2, RP

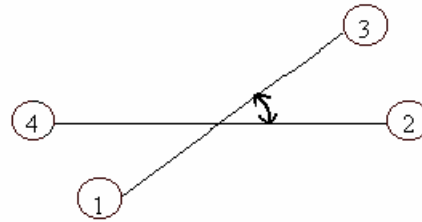
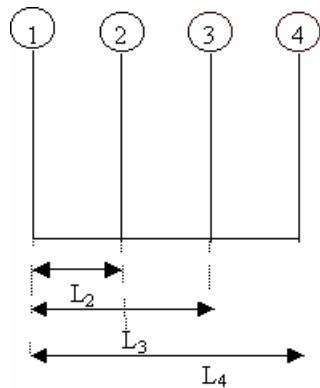

PLANE	Weight. NO.	Mass(kg) m	Radius (r)	Angle (°)	Mass Moment (mr)	Distance from R.P. (L)	Couple (mrl)
(1)	(2)	(3)	(4)	(5)	(6)	(7)	(8)
1(R.P.)	1	$m_1$	$r_1$	1	$m_1 r_1$	0	0
2	2	$m_2$	$r_2$	$\theta_2=0$	$m_2 r_2$	$L_2$	$m_2 r_2 L_2$
3	3	$m_3$	$r_3$	3	$m_3 r_3$	$L_3$	$m_3 r_3 L_3$
4	4	$m_4$	$r_4$	4	$m_4 r_4$	$L_4$	$m_4 r_4 L_4$

The angular position of mass  $m_1$  must be equal to the angle in anticlockwise measured from the R.P. to the line drawn on the fig. parallel to the closing side of force polygon.

**DESCRIPTION:**

The apparatus consists of a steel shaft mounted in ball bearings in a stiff rectangular main frame. A set of four blocks of different weights is provided and may be detached from the shaft.

A disc carrying a circular protractor scale is fitted to one side of the rectangular frame. A scale is provided with the apparatus to adjust the longitudinal distance of the blocks on the shaft. The circular protractor scale is provided to determine the exact angular position of each adjustable block. The shaft is driven by electric motor mounted under the main frame, through a belt. For static balancing of weights the main frame is suspended to support frame by chains then rotate the shaft manually after fixing the blocks at their proper angles. It should be completely balanced. In this position, the mo for dynamic balancing of the rotating mass system, the main frame is suspended from the support frame by two short links such that the main frame and the supporting frame are in the same plane. Rotate the statically balanced weights with the help of motor. If they rotate smoothly and without vibrations, they are dynamically balanced or driving belt should be removed.

**EXPERIMENTAL PROCEDURE:**

1. Insert all the weights in sequence 1- 2- 3 - 4 from pulley side.
2. Fix the pointer and pulley on shaft.
3. Fix the pointer on 0 o ( $\theta_2$ ) on the circular protractor scale.
4. Fix the weight no. 1 in horizontal position.
5. Rotate the shaft after loosening previous position of pointer and fix it on  $\theta_3$ .
6. Fix the weight no. 2 in horizontal position.
7. Loose the pointer and rotate the shaft to fix pointer on  $\theta_4$ .
8. Fix the weight no. 3 in horizontal position.
9. Loose the pointer and rotate the shaft to fix pointer on  $\theta_1$ .
10. Fix the weight no.4 in horizontal position.
11. Now the weights are mounted in correct position.
12. For static balancing, the system will remain steady in any angular position.
13. Now put the belt on the pulleys of shaft and motor.
14. Supply the main power to the motor through dimmer stat.
15. Gradually increase the speed of the motor. If the system runs smoothly and without vibrations, it shows that the system is dynamically balanced.
16. 17. Gradually reduce the speed to minimum and then switch off the main supply to stop the system.

**OBSERVATION TABLE:**

S. NO.	Plane	Mass, m (gms)	Angle from reference line ( )	Distance (L) mm
1	1			
2	2(R.P.)			
3	3			
4	4			

**CALCULATION TABLE:**

Plane	Mass, m	Mass Moment (m )	Couple (m )
1			
2			
3			
4			

**NOMENCLATURE:**

L = Distance between particular weight from weight 1, mm

W = Mass of particular weight, kg

$\theta$  = Angle of particular weight from Reference Point, degree

**PRECAUTIONS & MAINTENANCE INSTRUCTIONS:**

- 1) Never run the apparatus if power supply is less than 180 volts & above than 230volts.
- 2) Increase the motor speed gradually.
- 3) Experimental set up should be tight properly before conducting experiment.
- 4) Before starting the rotary switch, dimmer stat should be at zero position.

**RESULT:****VIVA QUESTIONS:**

- 1) Write the importance of balancing?
- 2) Differentiate: static and dynamic balancing.
- 3) Can a single cylinder engine be fully balanced? Why?
- 4) Define tractive force.
- 5) What are the effects of hammer blow and swaying couple?



## **EXPERIMENT NO. 4**

### **DYNAMIC FORCE ANALYSIS**

#### **AIM:**

- To balance the masses Statically & Dynamically of a simple rotating mass system and to observe the effect of unbalance in a rotating mass system.

#### **APPARATUS:**

- Rotating mass balance system.

#### **THEORY:**

- **CONDITIONS FOR DYNAMIC BALANCING:**

If a shaft carries a number of unbalanced masses such that the center of mass of the system lies on the axis of rotation, the system is said to statically balance. The resultant couple due to all the inertia forces during rotation must be zero.

These two conditions together will give complete dynamic balancing. It is obvious that a dynamically – balanced system is also statically balanced, but the statically balanced system is not dynamically balanced.

- **BALANCING OF SEVERAL MASSES ROTATING IN DIFFERENT PLANES:**

When several masses revolve in different planes, they may be transferred to a reference plane (written as RP), which may be defined as the plane passing through a point on the axis of rotation and perpendicular to it. The effect of transferring a revolving mass (in one plane) to a reference plane is to cause a force of magnitude equal to centrifugal force of the revolving mass to act in the reference plane, together with a couple of magnitude equal to the product of the force and the distance between the plane of rotation and the reference plane. In order to have a complete balance of the several revolving masses in different planes, the following conditions must be satisfied:

1. The forces in the reference plane must balance, i.e. the resultant force must be zero.
2. The couple about the reference plane must balance, i.e. the resultant couple must be zero.

Let us now consider four masses  $m_1$ ,  $m_2$ ,  $m_3$  and  $m_4$  revolving in planes 1, 2, 3 and 4 shown in fig. The relative angular positions of these masses are shown in the end view

Fig. The magnitude, angular position and position of the balancing mass  $m_1$  in plane 1 may be obtained as discussed below:

1. Take one of the planes, say 1 as the reference plane (R.P.). The distance of all the other planes to the left of the reference plane may be regarded as negative, and those to the right as positive.
2. Tabulate the data as in table. The planes are tabulated in the same order i.e. 1, 2, 3, RP

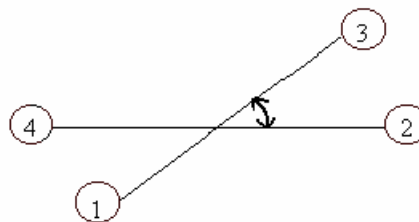
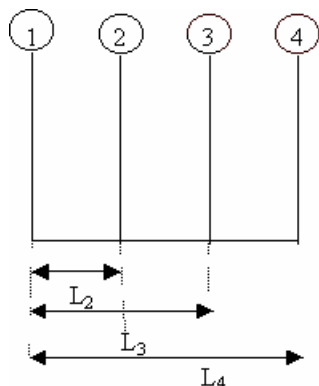

PLANE	Weight. NO.	Mass(kg) m	Radius (r)	Angle (°)	Mass Moment (mr)	Distance from R.P. (L)	Couple (mrl)
(1)	(2)	(3)	(4)	(5)	(6)	(7)	(8)
1(R.P.)	1	$m_1$	$r_1$	1	$m_1 r_1$	0	0
2	2	$m_2$	$r_2$	$\alpha_2 = 0$	$m_2 r_2$	$L_2$	$m_2 r_2 L_2$
3	3	$m_3$	$r_3$	3	$m_3 r_3$	$L_3$	$m_3 r_3 L_3$
4	4	$m_4$	$r_4$	4	$m_4 r_4$	$L_4$	$m_4 r_4 L_4$

1. The position of plane 4 from plane 2 may be obtained by drawing the couple Polygon with the help of data given in column no. 8.
2. The magnitude and angular position of mass  $m_1$  may be determined by drawing the force polygon from the given data of column no.5 & column no.6 to some suitable scale. Since the masses are to be completely balanced, therefore the force polygon must be closed figure. The closing side of force polygon is proportional to the  $m_1 r_1$ .

The angular position of mass  $m_1$  must be equal to the angle in anticlockwise measured from the R.P. to the line drawn on the fig. parallel to the closing side of force polygon.

### DESCRIPTION:

The apparatus consists of a steel shaft mounted in ball bearings in a stiff rectangular main frame. A set of four blocks of different weights is provided and may be detached from the shaft.

A disc carrying a circular protractor scale is fitted to one side of the rectangular frame. A scale is provided with the apparatus to adjust the longitudinal distance of the blocks on the shaft. The circular protractor scale is provided to determine the exact angular position of each adjustable block. The shaft is driven by electric motor mounted under the main frame, through a belt. For static balancing of weights the main frame is suspended to support frame by chains then rotate the shaft manually after fixing the blocks at their proper angles. It should be completely balanced. In this position, the mo for dynamic balancing of the rotating mass system, the main frame is suspended from the support frame by two short links such that the

main frame and the supporting frame are in the same plane. Rotate the statically balanced weights with the help of motor. If they rotate smoothly and without vibrations, they are dynamically balanced or driving belt should be removed.

**EXPERIMENTAL PROCEDURE:**

1. Insert all the weights in sequence 1- 2- 3 - 4 from pulley side.
2. Fix the pointer and pulley on shaft.
3. Fix the pointer on 0 o ( $\theta_2$ ) on the circular protractor scale.
4. Fix the weight no. 1 in horizontal position.
5. Rotate the shaft after loosening previous position of pointer and fix it on  $\theta_3$ .
6. Fix the weight no. 2 in horizontal position.
7. Loose the pointer and rotate the shaft to fix pointer on  $\theta_4$ .
8. Fix the weight no. 3 in horizontal position.
9. Loose the pointer and rotate the shaft to fix pointer on  $\theta_1$ .
10. Fix the weight no.4 in horizontal position.
11. Now the weights are mounted in correct position.
12. For static balancing, the system will remain steady in any angular position.
13. Now put the belt on the pulleys of shaft and motor.
14. Supply the main power to the motor through dimmerstat.
15. Gradually increase the speed of the motor. If the system runs smoothly and without vibrations, it shows that the system is dynamically balanced.
17. Gradually reduce the speed to minimum and then switch off the main supply to stop the system.

**OBSERVATION & CALCULATIONS:**

**OBSERVATION TABLE:**

S. NO.	Plane	Mass, m (gms)	Angle from reference line ( )	Distance (L) mm
1	1			
2	2(R.P.)			
3	3			
4	4			

**CALCULATION TABLE:**

Plane	Mass, m	Mass Moment (m )	Couple (m )
1			
2			
3			
4			

**NOMENCLATURE:**

L = Distance between particular weight from weight 1, mm

W = Mass of particular weight, kg

$\theta$  = Angle of particular weight from Reference Point, degree

**PRECAUTIONS & MAINTENANCE INSTRUCTIONS:**

- 1) Never run the apparatus if power supply is less than 180 volts & above than 230volts.
- 2) Increase the motor speed gradually.
- 3) Experimental set up should be tight properly before conducting experiment.
- 4) Before starting the rotary switch, dimmer stat should be at zero position.

**RESULT:****VIVA QUESTIONS:**

- 1) Write the importance of balancing?
- 2) Differentiate: static and dynamic balancing.
- 3) Can a single cylinder engine be fully balanced? Why?
- 4) Define tractive force.
- 5) What are the effects of hammer blow and swaying couple?

## EXPERIMENT NO. 5 BALANCING

### AIM:

- To Determine the Balancing Forces and Reciprocating Masses

### APPARATUS:

- Reciprocating Masses Test rig

### THEORY:

- Various forces acting on the reciprocating parts of an engine. The resultant of all the forces acting on the body of the engine due to inertia forces only is known as unbalanced force or shaking force. Thus if the resultant of all the forces due to inertia effects is zero, then there will be no unbalanced force, but even then an unbalanced couple or shaking couple will be present.

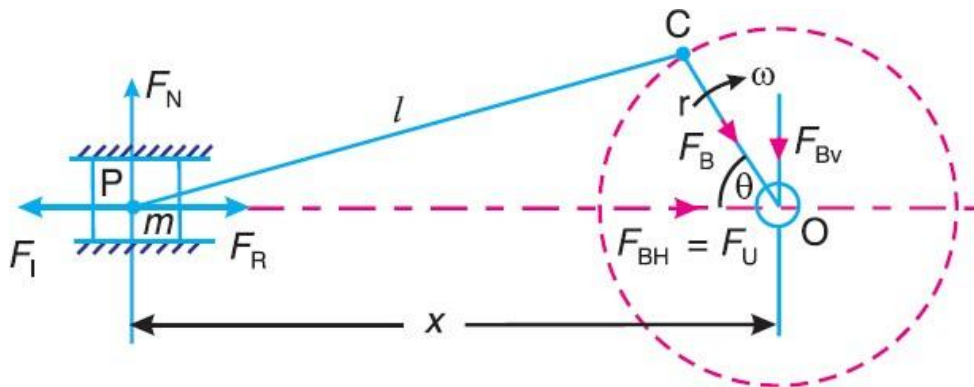

Reciprocating engine mechanism

$F_R$  = Force required to accelerate the reciprocating parts,

$F_I$  = Inertia force due to reciprocating parts,

$F_N$  = Force on the sides of the cylinder walls or normal force acting on the cross-head guides, and  $F_B$  = Force acting on the crankshaft bearing or main bearing.

Since  $F_R$  and  $F_I$  are equal in magnitude but opposite in direction, therefore they balance each other. The horizontal component of  $F_B$  (i.e.  $F_{BH}$ ) acting along the line of reciprocation is also equal and opposite to  $F_I$ . This force  $F_{BH} = F_U$  is an unbalanced force or shaking force and required to be properly balanced.

The force on the sides of the cylinder walls ( $F_N$ ) and the vertical component of  $F_B$  (i.e.  $F_{BV}$ ) are equal and opposite and thus form a shaking couple of magnitude  $F_N \times x$  or  $F_{BV} \times x$ . From above we see that the effect of the reciprocating parts is to produce a shaking force and a shaking couple. Since the shaking force and a shaking couple vary in magnitude and direction during the engine cycle, therefore they cause very objectionable vibrations.

Thus the purpose of balancing the reciprocating masses is to eliminate the shaking force and a shaking couple. In most of the mechanisms, we can reduce the shaking force and a shaking couple by adding appropriate balancing mass, but it is usually not practical to eliminate them completely. In other words, the reciprocating masses are only partially balanced.

Note: The masses rotating with the crankshaft are normally balanced and they do not transmit any unbalanced or shaking force on the body of the engine.

### **PRIMARY AND SECONDARY UNBALANCED FORCES OF RECIPROCATING MASSES:**

Consider a reciprocating engine mechanism as shown in Fig.

Let  $m$  = Mass of the reciprocating parts,

$l$  = Length of the connecting rod PC,

$r$  = Radius of the crank OC,

$\theta$  = Angle of inclination of the crank with the line of stroke PO,

$\omega$  = Angular speed of the crank,

$n$  = Ratio of length of the connecting rod to the crank radius =  $l / r$ .

Unbalanced force,

$$F_U = m \cdot \omega^2 \cdot r \left( \cos \theta + \frac{\cos 2\theta}{n} \right) = m \cdot \omega^2 \cdot r \cos \theta + m \cdot \omega^2 \cdot r \times \frac{\cos 2\theta}{n} = F_P + F_S$$

The expression ( $m \cdot \omega^2 \cdot r \cos \theta$ ) is known as primary unbalanced force and

$[m \cdot \omega \cdot r \times (\cos \theta) / n]$  is called secondary unbalanced force

### **RESULT:**

### **VIVA QUESTIONS:**

- 1) The journal bearings are generally used in.
- 2) The basic type of motion of a body is not the translation motion only.
- 3) Coplanar forces are not easily simplified in the simplification of the force and couple system in the calculations of forces in the journal bearings.
- 4) The moment of the force is the product of the force and the perpendicular distance of the axis and the point of action of the force. Is this also true for rolling?

## EXPERIMENT NO. 6

### JOURNAL BEARING

#### AIM:

- To determine the Sommerfeld pressure function agrees with the experimental pressure curve within reasonable limits./ To study the pressure profile of lubricating conditions of load and speed.

#### APPARATUS:

- Journal Bearing Apparatus

#### THEORY:

- The Mathematical analysis of the behavior of journal in a bearing falls into two distinct categories as given in the appendix of this manual. They are,
  - Hydrodynamics of fluid flow between plates.
  - Journal bearing analysis where the motion of the journal in the oil film is considered.

According to equation the Sommerfeld pressure function (When the velocity of the eccentricity and the whirl speed of the journal are both zero) is given by

$$P - P_0 = \frac{-\delta \mu r^2 \omega}{\delta^2 (2 + n^2)} \cdot \frac{h \sin \theta (2 + n \cos \theta)}{(1 + n \cos \theta)^2}$$

Where P is the pressure of the oil film at the point measured clockwise from the line of common centers (00'') and P = P<sub>0</sub> at  $\theta = 0$  and  $\theta = \pi$  refer the fig.

Note: – Some books on lubrication give the Sommerfeld function with a negative sign for n. This is true if it is measured from the point of minimum thickness of the oil film that is

$$h = \delta (1 - n \cos \theta)$$

It is also proved in the analysis that maximum pressure occurs at

$$\cos \theta_m = \frac{3n}{2 + n^2}$$

Hence minimum pressure occurs at the point  $\theta = -\theta_m$ . The total load „P“ on the journal is given by equation (acting perpendicular to the line of centers oo'')

$$P = \frac{-12 \mu r^3 L \omega \pi}{\delta^2} \cdot \frac{n}{2 + n^2} \cdot \frac{1}{\sqrt{1 - n^2}}$$

Where L is width of the bearing and the total force along oo' is zero.

The total tractional couple ‘M’ necessary to rotate the journal is given by

$$M = \frac{4 \mu r^3 \omega \pi L}{\delta} \cdot \frac{1 + 2n^2}{(2 + n^2) \sqrt{1 - n^2}}$$

- i) When comparing the above expression for pressures, load and so on, with experimental data obtained from the small journal bearing rig,  $\theta$  must be measured from the point where the thickness of the oil film is maximum and in the anticlockwise direction.
- ii)  $P - P_0 = 0$  at  $\theta = 0$  and  $\theta = \pi$   
i. e.  $P = P_0$  at  $180^\circ$  apart from zero.

That is on the pressure curve ( head of oil / angular position ) select two points of equal pressure  $180^\circ$  apart of these two points take as origin the point where the thickness of the oil film is greater, and measure anticlockwise to plot the Sommerfield pressure curve after determining graphically the values of „n“ from :

$$\cos \theta_m = \frac{-3n}{2 + n^2}$$

and the value „K“ in

$$(P - P_0) \max. = \frac{-K \sin \theta_m (2 + n \cos \theta_m)}{(1 + n \cos \theta_m)^2}$$

Where „K“ has the same units of dimensions as „P“, „n“ is non dimensional.

#### RANGE OF EXPERIMENTS:

Determine the pressure distribution in the oil film of the bearing for various speed and

- a) Plot the Cartesian and polar pressure curves for various speeds.

b) Determine the constants „n“ and „K“ = 
$$\frac{6 \mu r^2 \omega n}{\delta^2 (2 + n^2)}$$

- c) Plot the Sommerfield pressure curve for each speed.

$$P - P_0 = \frac{-K \sin \theta (2 + n \cos \theta)}{(1 + n \cos \theta)^2}$$

- d) Compare the mean load, due to the mean upward pressure on the projected and developed areas of the bearing with the total applied load.
- e) With the aid of the values of „n“ and „K“ determined as above for each speed, determine the total load on the journal

$$P = \frac{12 \mu r^3 L \omega \pi}{\delta^2} \cdot \frac{n}{2 + n^2} \cdot \frac{1}{\sqrt{1 - n^2}}$$

and compare with total load on the bearing. Determination of tractional torque.



## SPECIFICATIONS:

- 1) Diameter of Journal = ( A ) =  $2R = 55\text{mm}$
- 2) Diameter of bearing = ( E ) =  $2r = 70\text{mm}$   
(With 16 radial tapings)
- 3) Bearing width = ( L ) =  $15\text{mm}$
- 4) Weight of bearing with attachment =  $1.7\text{ kg}$
- 5) Weight of balancing load = ( J ) =
- 6) Set of weights is provided.
- 7) Motor D. C. =  $0.5\text{ HP, } 1500\text{ rpm. Variable speed.}$
- 8) Dimmer state is provided for speed variation.
- 9) Manometer board with 16 tubes and suitable height with suitable scales and adjustable oil tank.
- 10) Recommended oil = Lubricating oil SAE 20 or SAE 30.
- 11) Supply required = A. C.,  $1\text{ HP, } 230\text{ V., } 50\text{ c/sec., stabilized.}$

## EXPERIMENTAL PROCEDURE:

- 1) Fill the oil tank by using SAE 20 or SAE 30 lubricating oil under test and position the tank at the desired height.
- 2) Drain out the air from all the tubes on the manometer and check level balance with supply level Indicator.
- 3) Check that some oil leakage is there. Some leakage of oil is necessary for cooling purpose.
- 4) Check the direction of rotation and increase the speed of the motor slowly.
- 5) Set the speed and let the journal run for about half an hour until the oil in the bearing is warmed up and check the steady oil levels at various tapings.
- 6) Add the required loads and keep the balancing rod in horizontal position by moving balancing weight „J” on the rod and observe the steady levels.
- 7) When the manometer levels have settled down, take the pressure readings on 1 to 12 manometer tubes. For circumferential pressure distribution and A-B-12-C-D tubes for axial pressure distribution.
- 8) Repeat the experiment for various speeds and loads.
- 9) After the test is over set dimmer to zero position and switch off main supply.
- 10) Keep the oil tank at lower most position so that there will be no leakage in the idle period.

## Graphs

- 1) Graph to be plotted for pressure head of oil above supply head in cm. of oil, at angular intervals of  $30^\circ$  of oil film. The angular interval position are measured clockwise, commencing with position marked „1” in Fig.
- 2) Graph is drawn for theoretical and experimental pressure curves for journal  $N_1 = N\text{ RPM.}$
- 3) Graph is plotted for experimental pressure curves along the length of bearing at these speeds.

### TYPICAL CALCULATION:

These calculations are based on sample readings and will differ from actual results and calculations for different unit. Data used in calculation is not pertaining to the actual unit supplied.

The method of drawing the theoretical Somerfield pressure curve is as follows:

Consider pressure curve for  $N_1 = N$  RPM.

- 1) Select two points A and B on the experimental pressure curve of equal pressure and  $180^\circ$  apart.
- 2) Note that for any pressure curve there will be only one such pair of points is possible. These two points A and B from the axis  $P - P_0 = 0$  for the Somerfield curve.
- 3) Of these two points take the point which is maximum thickness of oil film and take  $\theta = 0$  to pass through this point.
- 4) From the graph determine the point of maximum pressure  $(P - P_0)_{\max}$ . in this case  $\theta = 206^\circ = -3n / 2 + n^2$

$$\therefore n = 0.8$$

$$\text{Also } 176 = \frac{-K \sin 206^\circ (2 + 0.8 \cos 206^\circ)}{(1 + 0.8 \cos 206^\circ)}$$

$$\therefore k = 24.5.$$

- 5) Now plot the curve  $P - P_0 = \frac{-24.5 \sin \theta (2 + 0.8 \cos \theta)}{(1 + 0.8 \cos \theta)^2}$   
(with B as origin)

### Load on the bearing

- 1) Total vertical load on bearing at N RPM.

$$\begin{aligned} &= \text{Dry weight of Bearing} + \text{Weight added} + \text{Weight of balancing load.} \\ &= 1.375 + 2 \times 0.150 + \text{added weight nil.} \\ &= 1.675 \text{ Kg.} \end{aligned}$$

- 2) Referring to fig. the mean positive pressure head of the oil above supply head.

$$\begin{aligned} &= (35.5 + 24 + \underline{18} + 12 + 8 + \underline{5} + 2 + \underline{60} + 177 + \underline{130}) / 10. \quad \text{---} \\ &= 45.5 \text{ cm.} \end{aligned}$$

Load carried by oil pressure on projected area of bearing

$$\begin{aligned} &= 45.5 \times \text{Density of oil} \times (2 R) L. \\ &= 45.5 \times 0.8539 \times 5.5 \times 6.8. \\ &= 1.450 \text{ kg.} \end{aligned}$$

The underlined figures are recorded from graph and balanced are practical result.

3) Maximum theoretical load on journal is „P“.

$$P = \frac{12 \mu L r \omega \pi}{\delta^2} \times \frac{n}{2 + n^2} + \frac{1}{\sqrt{1 - n^2}}$$

$$= \frac{K \times 2 \pi r^3 L}{\sqrt{1 - n^2}} \times \text{Density of oil.}$$

$$= \frac{24.5 \times 2 \times 3.142 \times 5/2 \times 6.8}{\sqrt{1 - 0.8^2}} \times 0.8539.$$

$$P = 3.724 \text{ Kg.}$$

4) Tractical torque = Balancing weight J x Length of arm of the weight L.

TABLE 1 –

Typical Results w. r. t. manometer tubes.

Ps = Supply Head =

Weight of Bearing =

Speed of Journal =

Sr. No.	Tube No.	Pressure Head in cm.
1	1	
2	2	
3	3	
4	4	
5	5	
6	6	
7	7	
8	8	
9	9	
10	10	
11	11	
12	12	
13	A	
14	B	
15	C	
16	D	

Table 2 –

PRESSURE HEAD OF OIL FILM ABOVE HEAD =  $(P - P_s)$  cm.

Shaft speed =                  RPM.

Sr. No.	Tube No.	Pressure Head in cm.
1	1	
2	2	
3	3	
4	4	
5	5	
6	6	
7	7	
8	8	
9	9	
10	10	
11	11	
12	12	
13	A	
14	B	
15	C	
16	D	

Note:  $P_o$  = Supply head of oil.

**OBSERVATIONS:**

The Somerfield pressure function agrees with the experimental pressure curve within reasonable limits as indicated in Fig. Any deviations between the experimental and theoretical curves can be due to –

- 1) Human error in taking readings, for example in deciding whether or not the oil levels in the manometer are absolutely steady before taking reading.
- 2) The theoretical analysis is based on the assumption that the thickness of the oil film  $h = \delta + e \cos \theta$  which is true only if the radial clearance is very small. In practical journal bearings this assumption is true but in this test rig  $\delta = 2.5$  mm. which is very large. This has been purposely done so that the oil film profile is clearly visible.
- 3) The total weight of the bearing is = 1.375 Kg. It can be seen that the oil film in the bearing does not carry this full weight, a part of weight appears to be taken by the seal, and the flexible plastic tubes attached to the bearing.

**RESULT:**

**VIVA QUESTIONS:**

- 1) The journal bearings are generally used in.
- 2) The basic type of motion of a body is not the translation motion only.
- 3) Coplanar forces are not easily simplified in the simplification of the force and couple system in the calculations of forces in the journal bearings.
- 4) The moment of the force is the product of the force and the perpendicular distance of the axis and the point of action of the force. Is this also true for rolling?
- 5) If a car is moving forward, what is the direction of the moment of the moment caused by the rolling of the tires, assume non slippery surface?

## **EXPERIMENT NO. 7**

### **LONGITUDINAL VIBRATION**

#### **AIM:**

- To study the longitudinal vibration of helical spring and to determine the frequency and time period of oscillation theoretically and actually by experiment.

#### **APPARATUS:**

- Longitudinal Vibration of Helical Spring testrig.

#### **DESCRIPTION:**

- One end of open coil spring is fixed to the nut having a hole which itself is mounted on a MS strip fixed on one side of the main frame. The lower end of the spring is attached to the platform carrying the weights. The stiffness of the spring can be finding out by varying the weights on the platform and by measuring the deflection of the spring. The time period of vibrations can be calculated by measuring the nos. of oscillation and time taken by them.

#### **EXPERIMENTAL PROCEDURE:**

1. Fix one end of the helical spring to upper screw.
2. Determine free length.
3. Put some weight to platform and note down the deflection.
4. Stretch the spring through some distance and release.
5. Count the time required in Sec. for say 10, 20 oscillations.
6. Determine the actual period.
7. Repeat the procedure for different weights.

#### **FORMULAE:**

1. Stiffness

$$k = \frac{W}{\delta} \text{ kg / cm}$$

2. Mean Stiffness,,

$$k_m = k_1 + k_2 + k_3$$

3. Theoretical time period,

$$T_{\text{theo}} = \frac{2}{\pi} \sqrt{\frac{w}{k_m * g}}$$

4. Theoretical frequency,

$$f_{\text{theo}} = \frac{1}{T_{\text{theo}}}$$

5. Actual time period,

$$T_{\text{act}} = \frac{t}{n} \text{ sec}$$

6. Actual frequency,

$$f_{\text{act}} = \frac{1}{T_{\text{act}}}$$

### OBSERVATION & CALCULATION TABLE - 1

S. No.	Wt. Attached, W Kg.	Deflection in spring $\delta$ cm.	Stiffness k Kg / cm	Mean Stiffness $K_m$ Kg / cm

### OBSERVATION & CALCULATION TABLE - 2

S. No.	Wt. Attached W kg.	No. Of Osc.	Time reqd. for n Osc. t (sec)	T theo (sec)	T expt (sec)	f theo (Hz)	f expt (Hz)

### NOMENCLATURE:

k	=	Stiffness of the spring
W	=	Weight applied
$\delta$	=	Deflection of the spring.
km	=	

- $g$  = Acceleration due to gravity  
 $n$  = No. of oscillations.  
 $t$  = Time taken by „n“ oscillation  
 $T_{act}$  = Actual time period  
 $T_{theo}$  = Theoretical time  
 $f_{act}$  = period Actual  
 $f_{theo}$  = frequency Theoretical

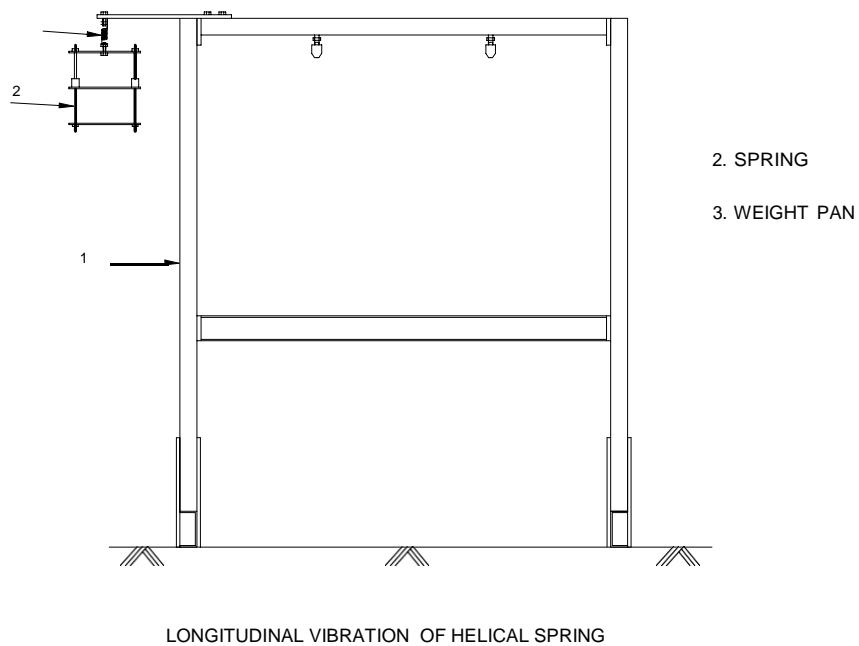

## RESULT:

## VIVA QUESTIONS:

- 1) When a body is subjected to transverse vibrations, the stress induced in a body will be?
- 2) The ratio of the maximum displacement of the forced vibration to the deflection due to the static force is known as.
- 3) The natural frequency (in Hz) of free longitudinal vibrations is equal to?
- 4) Define resonance.



## **EXPERIMENT NO. 8**

### **VIBRATION ANALYSIS OF SHAFT**

#### **AIM:**

- To determine the frequency of different shafts.

#### **APPARATUS:**

- Vibration Analysis of Shaft test rig

#### **THEORY:**

This apparatus is developed for the demonstration of whirling phenomenon. The shaft can be tested for different end conditions.

The apparatus consists of a frame to support its driving motor, end fixing and sliding blocks etc. A special design is provided to clear out the effects of bearings of motor spindle from those of testing shafts. The special design features of this equipment are as follows.

A) Coupling – A flexible shaft is used to drive the test shaft from motor.

B) Ball Bearing Fixing Ends –

These ends fix the shafts while it rotates. The shaft can be replaced within short time with the help of this unit. The fixing ends provide change of end fixing condition of the rotating shaft as per the requirement.

#### **SHAFT SUPPLIED WITH THE EQUIPMENT:**

Polishing spring steel shafts are supplied with the machine, the dimensions being as under,

Shaft No.	Diameter in mm	Length in inch ( Approximately in cm)
1	4mm	35.5", (90 cm)
2	6mm	35.5", (90 cm)
3	8mm	35.5", (90 cm)

#### **END FIXING ARRANGEMENT:**

At motor end as well as tail end different bearing blocks can be fixed which are as follows,

- 1) Supported end condition – Make use of end block with single self aligning bearing.
- 2) Fixed end condition – Make use of end block with double bearing.

### Guards D1, D2 and D3 –

The guards can be fixed at any position on the supporting frame which fits on the side supports. Rotating shafts are to be fitted in blocks in A and B stands.

### SPEED CONTROL OF DRIVING MOTOR –

The driving motor is 240 volts, frictional HP, 5000 rpm, 50 Hz, and speed control unit is a Dimmerstat of 240 volts, 2 Amp. 50 Hz.

### MEASUREMENT OF SPEED –

To measure the speed of the rotating shaft a simple Tachometer may be used (will not be supplied with the equipment) on the opposite side of the shaft extension of the motor.

Whirling of elastic shaft –

If,  $L$  = Length of the shaft in cm.

$E$  = Young's Modulus Gpa = 73 in torsion and 193Gpa in tension

$I$  = 2<sup>nd</sup> moment of inertia of the shaft cm<sup>4</sup>.

$W$  = Weight of the shaft per unit length Kg /cm.

$g$  = Acceleration due to gravity in m / sec<sup>2</sup> = 9.81

Then the frequency of vibration for the various modes is given by the equation,

$$f = k \times \sqrt{\frac{E I g}{W L^4}}$$

The various values of „k“ are given below,

Sr. No.	End Conditions	Value of k	
		1 <sup>st</sup> mode	2 <sup>nd</sup> mode
1	Supported, Supported	1.57	6.28
2	Fixed, Supported	2.45	9.80
3	Fixed, Fixed	3.56	14.24

**Data –**

Sr. No.	Shaft Dia.	$I = \text{cm}^4$	$W = \text{Kg/cm}$
1	$3/16'' = 0.47 \text{ cm.}$	$25.39 \times 10^{-4}$	$0.15 \times 10^{-2}$
2	$1/4'' = 0.64 \text{ cm.}$	$79.91 \times 10^{-4}$	$0.28 \times 10^{-2}$
3	$5/16'' = 0.79 \text{ cm.}$	$194.78 \times 10^{-4}$	$0.424 \times 10^{-2}$

**PRECAUTIONS TO BE OBSERVED IN EXPERIMENTS:**

1) If the revolution of an unloaded shaft are gradually increased it will be found that a certain speed will be reached at which violent instability will occur, the shaft deflecting into a single bow and whirling round like a skipping rope. If this speed is maintained the deflection will become so large that shaft will be fractured, but if this speed is quickly run through the shaft will become straight again and run true until at another higher speed the same phenomenon will occur, the deflection now however, being in a double bow and so on. Such speeds are called critical speeds of whirling.

2) It is advisable to increase the speed of shaft rapidly and pass through the critical speed first rather than observing the 1<sup>st</sup> critical speed which increases the speed of rotation slowly. In this process there is possibility that the amplitude of vibration will increase suddenly bringing the failure of the shaft.

If however the shaft speed is taken to maximum first and then slowly reduced, ( thus not allowing time to build-up the amplitude of vibration at resonance ) higher mode will be observed first and the corresponding speed noted and then by reducing the speed further the next mode of lower frequency can be observed without any danger of rise in amplitude as the speed is being decreased and the inertia forces are smaller in comparison with the bending spring forces hence possibility of build up dangerous amplitudes at resonance or near resonance is avoided.

3) Thus it can be seen that it is a destructive test of shafts and it is observed that the elastic behavior of the shaft material changes a little after testing it for a few times and it is advisable therefore, to use fresh shaft samples afterwards.

4) Fix the apparatus firmly on the suitable foundation.

**TYPICAL TEST OBSERVATION:**

- 1) Both ends of shafts free (Support) 1<sup>st</sup> and 2<sup>nd</sup> mode of vibration can be observed on shafts with 3/16" dia. And 1/4" dia.
- 2) One end of shaft fixed and the other free, 1<sup>st</sup> and 2<sup>nd</sup> mode of vibration can be observed on the shaft with 3/16" dia.
- 3) Both ends of shaft fixed – 2<sup>nd</sup> mode of vibration cannot be observed on any of the shafts as the speeds are very high and hence beyond the range of the apparatus.
- 4) There is difference between theoretical speed of whirling and actual speed observed, due to following reasons :
  - a) The end conditions are not as exact as assumed in theory.
  - b) Pressure of damping at the end bearings.
  - c) Assumptions made in theoretical predictions.
  - d) Lack of knowledge of exact properties of shaft material.
  - e) A uniformly loaded shaft has, theoretically infinite no. of natural frequencies of transverse vibration for fundamental mode observation of the first mode of whirling is therefore not so defined and thus difficult 2<sup>nd</sup> can be very easily observed.

**RESULT:****VIVA QUESTIONS:**

- 1) Define time period related to vibratory motion.
- 2) Define time cycle related to vibratory motion.
- 3) Name different types of free vibrations.
- 4) Define longitudinal vibrations.
- 5) Name different types of vibrations.

## EXPERIMENT NO. 9 MECHANISM

### AIM:

- To Study the Double Slider Crank and Geneva Mechanism

### APPARATUS:

- Double Slider Crank Mechanism
- Geneva Mechanism

### THEORY:

#### DOUBLE SLIDER CRANK MECHANISM

Double Slider Crank Chain A four bar chain having two turning and two sliding pairs such that two pairs of the same kind are adjacent is known as double slider crank chain.

Inversions of Double slider Crank chain: It consists of two sliding pairs and two turning pairs. They are three important inversions of double slider crank chain. 1) Elliptical trammel. 2) Scotch yoke mechanism. 3) Oldham's Coupling.

#### 1. Elliptical Trammel:

This is an instrument for drawing ellipses. Here the slotted link is fixed. The sliding block A and B in vertical and horizontal slots respectively. The end R generates an ellipse with the displacement of sliders A and B.

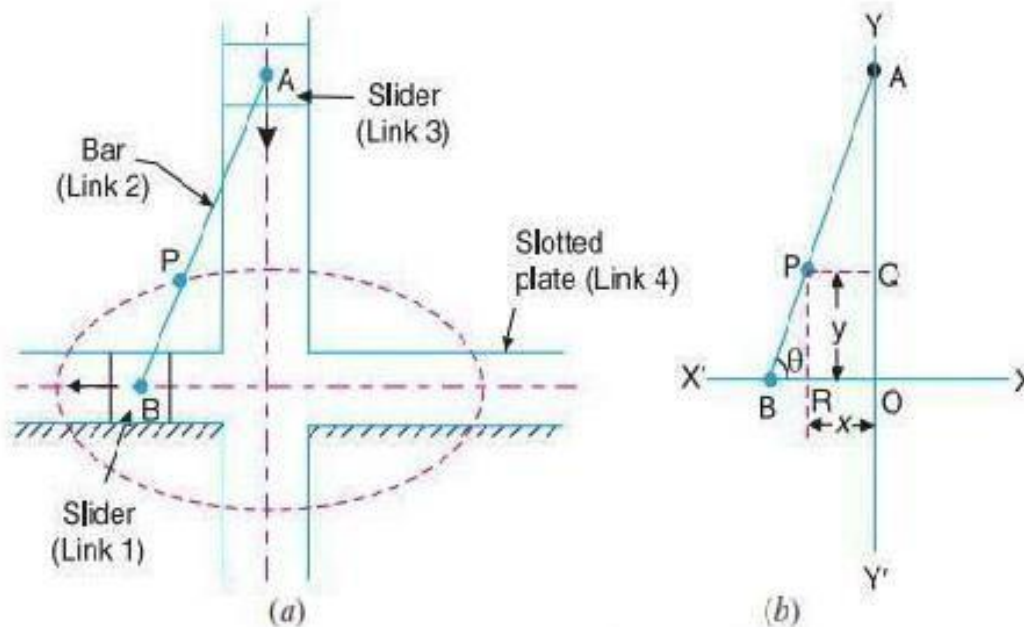

The co-ordinates of the point R are x and y. From the fig.  $\cos \theta = \frac{x}{OR}$  and  $\sin \theta = \frac{y}{OQ}$

Squaring and adding (i) and (ii) we get

$$\begin{array}{r} \text{---} \quad \text{---} \\ \quad \quad \quad \text{---} \quad \text{---} \end{array}$$

The equation is that of an ellipse, hence the instrument traces an ellipse. Path traced

2. **Scotch yoke mechanism:** This mechanism, the slider A is fixed. When AB rotates above A, the slider B reciprocates in the vertical slot. The mechanism is used to convert rotary to reciprocating mechanism. Consider fig a and b.

## GENEVA MECHANISM

### INTRODUCTION

The Geneva drive or Maltese cross is a gear mechanism that translates a continuous rotation movement into intermittent rotary motion. The rotating drive wheel is usually equipped with a pin that reaches into a slot located in the other wheel (driven wheel) that advances it by one step at a time.

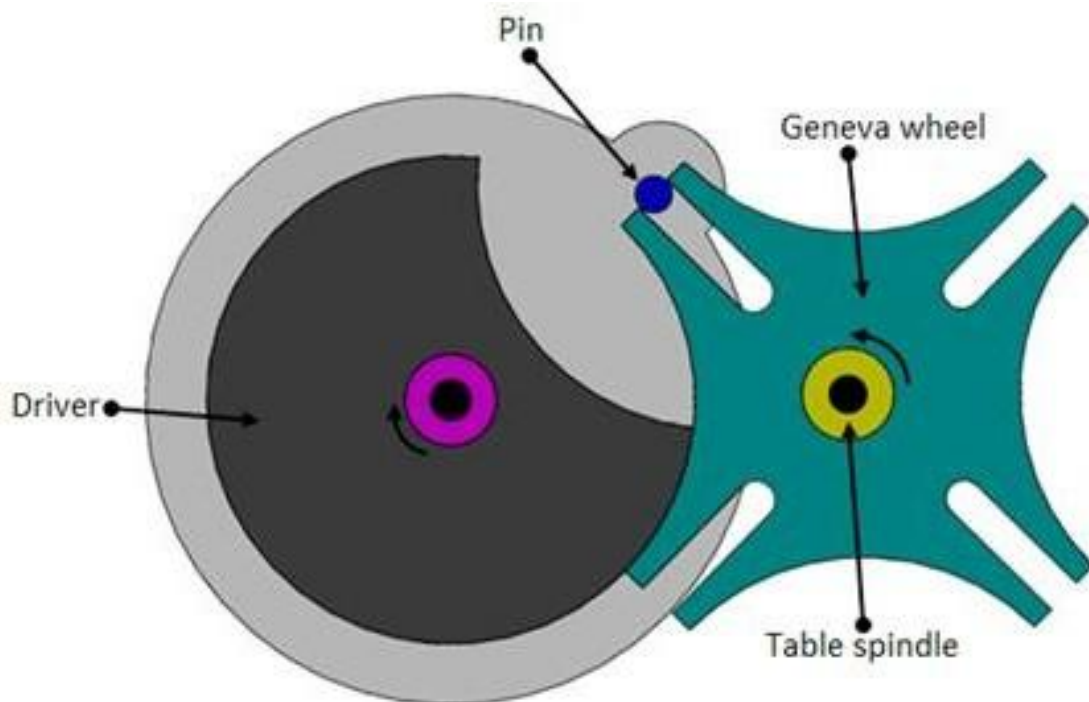

## CLASSIFICATION OF GENEVA MECHANISM

### 1. External Gear Mechanism

In this type of mechanism, the Geneva cross is connected with cam drive externally which is the most popular and can withstand higher mechanical stresses. The driver grooves lock the driven wheel pins during dwell. During movement, the driver pin with the driver-wheel slot.

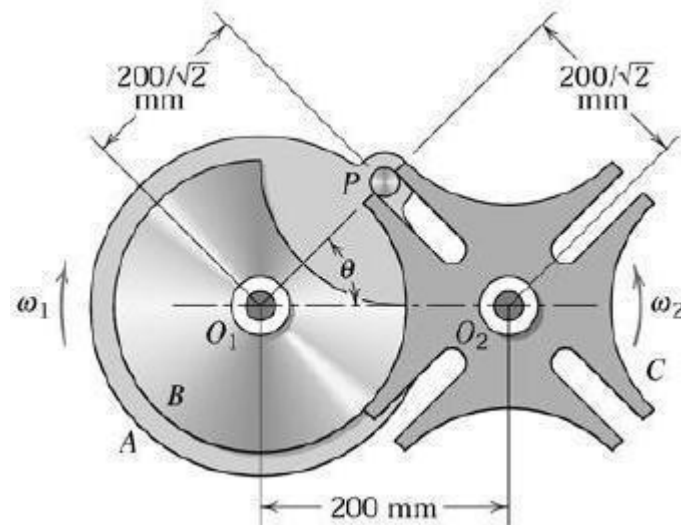

### 2. Internal Gear Mechanism

In this type of mechanism the Geneva cross and cam drive are connected internally in the closed box. The driver and driven wheel rotate in same direction. The duration of dwell is more than the  $180^\circ$  of driver rotation.

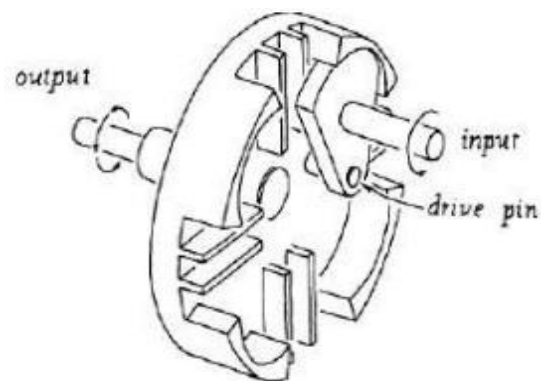
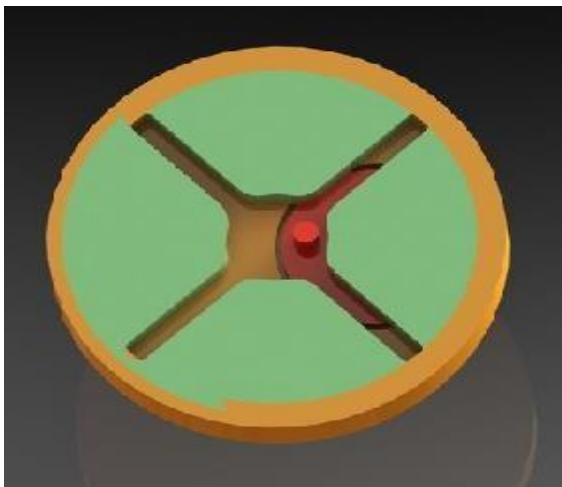

### 3. Spherical Geneva Mechanism

In this type of mechanism, the Geneva cross is in spherical shape and cam drive is connected in externally, which is extremely rare. The driver and driven wheel are on perpendicular shafts. The duration of dwell is exactly  $180^\circ$  of driven rotation.

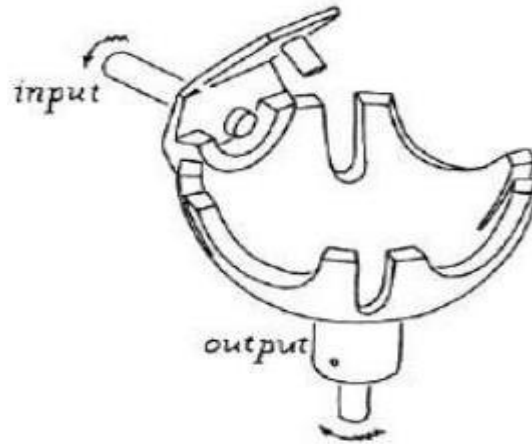

### Working of Geneva Mechanism

In the most common arrangement, the driven wheel has four slots and thus advances by one step of 90 degree for each rotation of the drive wheel. If the driven wheel has  $n$  slots, it advances by 360 degree per  $n$  full rotation of the drive wheel.

Geneva are also combined with variety of other mechanism, such as four bar linkages, clutch-brake combination, Non- circular gears etc to modify the motion curves and dwell motion ratios obtained from pure Geneva.

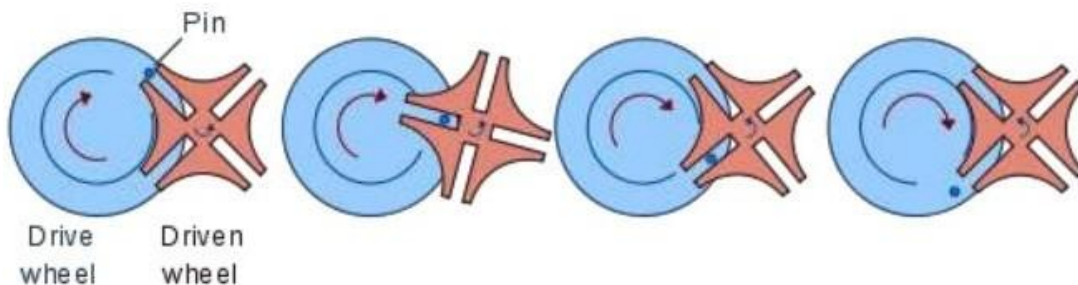

### Advantages of Geneva Mechanism

- Geneva Mechanism may be the simplest and least Expensive of all intermittent motion mechanism.
- They come in a wide variety of sizes, ranging from those used in instrument, to those used in machine tools to index spindle carriers weighing several tons.
- They have good motion curves characteristics compared to ratchets, but exhibit more “jerk” or instantaneous change in acceleration, than better cam systems.

### Disadvantages of Geneva Mechanism

- The Geneva is not a versatile mechanism and produce jerk.



- b) The ratio of dwell period to motion is also established once the no of dwells per revolution has been selected.
- c) All Geneva acceleration curves start and end with finite acceleration and deceleration.

### **Application of Geneva Mechanism**

- It is applicable in the production industries and automobile industries for mass production.
- Modern film projectors may also use an electronically controlled indexing mechanism or stepper motor, which allows for fast-forwarding the film.
- Geneva wheels having the form of the driven wheel were also used in mechanism watches, but not in a drive, rather to limit the tension of the spring, such that it would operate only in the range where its elastic force is nearly linear.
- Indexing table in assembly lines, tool changers for CNC machine, and so on.

### **RESULT:**

### **VIVA QUESTIONS:**

- 1) Define machine & structure.
- 2) Concept of kinematics links, pairs, chains & mechanism.
- 3) Classification & examples of all the kinematics links, pairs, chains & mechanism.
- 4) Grashof's criterion.
- 5) Types & examples of constrained motion.

## **EXPERIMENT NO. 10**

### **GEAR BOX**

#### **AIM:**

- To study the Gear Box assembly.

#### **APPARATUS:**

- Automobile gear box

#### **THEORY:**

#### **FUNCTION OF TRANSMISSION BOX (GEAR BOX) IN AUTOMOBILE:**

The transmission box which is also known as the gear box is the second element of the power train in an automobile. It is used to change the speed and torque of vehicle according to variety of road and load conditions. Transmission box change the engine speed into torque when climbing hills and when the vehicle required. Sometimes it is known as torque converter. Main functions of a gear box are as follow:

1. Provide the torque needed to move the vehicle under a variety of road and load conditions. It does this by changing the gear ratio between the engine crankshaft and vehicle drive wheels.
2. Be shifted into reverse so the vehicle can move backward.
3. Be shifted into neutral for starting the engine.

#### **MAIN COMPONENTS OF A GEAR BOX:**

In any device two or more component works together and full fills the required function. In a transmission box four components are required to fulfil its function. These components are-

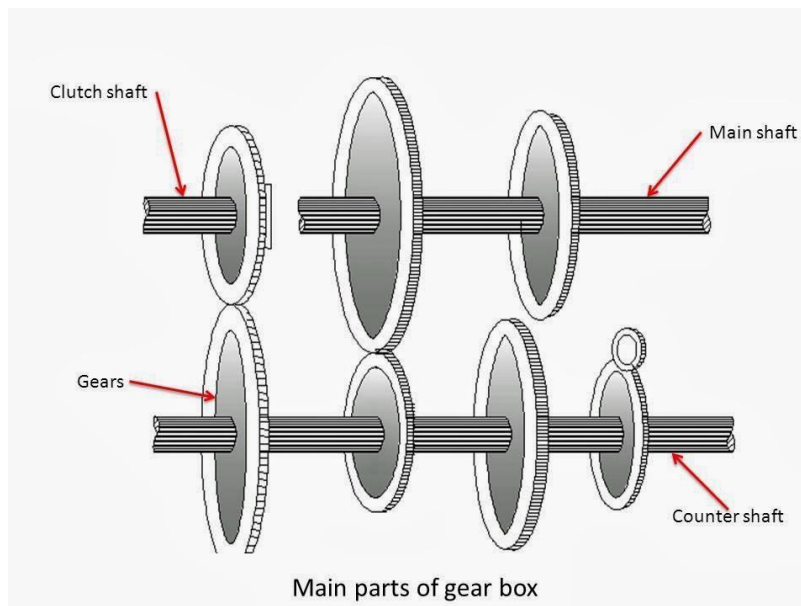

**a) Counter shaft:**

Counter shaft is a shaft which connects with the clutch shaft directly. It contains the gear which connects it to the clutch shaft as well as the main shaft. It may be run at the engine speed or at lower than engine speed according to gear ratio.

**b) Main shaft:**

It is the shaft which runs at the vehicle speed. It carries power from the counter shaft by use of gears and according to the gear ratio, it runs at different speed and torque compares to counter shaft. One end of this shaft is connects with the universal shaft.

**c) Gears:**

Gears are used to transmit the power from one shaft to another. They are most useful component of gear box because the variation is torque of counter shaft and main shaft is depends on the gear ratio. The gear ratio is the ratio of the driven gear teeth to the driving gear teeth. If gear ratio is large than one, the main shaft revolves at lower speed than the counter shaft and the torque of the main shaft is higher than the counter shaft. On other hand if the gear ratio is less than one, than the main shaft revolves at higher speed than the counter shaft and the torque of the main shaft is lower than the counter shaft. A small car gear box contains four speed gear ratio and one reverse gear.

**d) Bearings:**

Whenever the rotary motion encounters, bearings are required to support the revolving part and reduce the friction. In the gear box both counter and main shaft are supported by the bearing.

**WORKING OF A PRINCIPLE GEAR BOX:**

In a gear box, the counter shaft is meshed to the clutch with a use of a couple of gears. So the counter shaft is always in running condition. When the counter shaft is bring in contact with the main shaft by use of meshing gears, the main shaft start to rotate according to the gear ratio. When driver want to change the gear ratio, simply press the clutch pedal which disconnect the counter shaft with engine and connect the main shaft with counter shaft by another gear ratio by use of gearshift lever. In an gear box, the gear teeth and other moving metal must not touch. They must be continuously separated by a thin film of lubricant. This prevents excessive wear and early failure. There for a gearbox runs partially filled with lubricant oil.

**SELECTIVE TYPE GEAR BOX**

It is the transmission in which any speed may be selected from the neutral position. In this type of transmission neutral position has to be obtained before selecting any forward or reverse gear. Some selective type gear boxes are,

1. Sliding mesh gear box
2. Constant mesh gear box with positive dog clutch.
3. Constant mesh gear box with synchromesh device.

**1. SLIDING MESH GEAR BOX**

- a) It is the simplest and oldest type of gear box.
- b) The clutch gear is rigidly fixed to the clutch shaft.

- c) The clutch gear always remains connected to the drive gear of countershaft.
- 
- d) The other lay shaft gears are also rigidly fixed with it.
  - e) Two gears are mounted on the main shaft and can be sliding by shifter yoke when shifter is operated.
  - f) One gear is second & top speed gear and the other is the first and reverse speed gears. All gears used are spur gears.
  - g) A reverse idler gear is mounted on another shaft and always remains connected to reverse gear of counter shaft.

### Sliding Mesh Gearbox

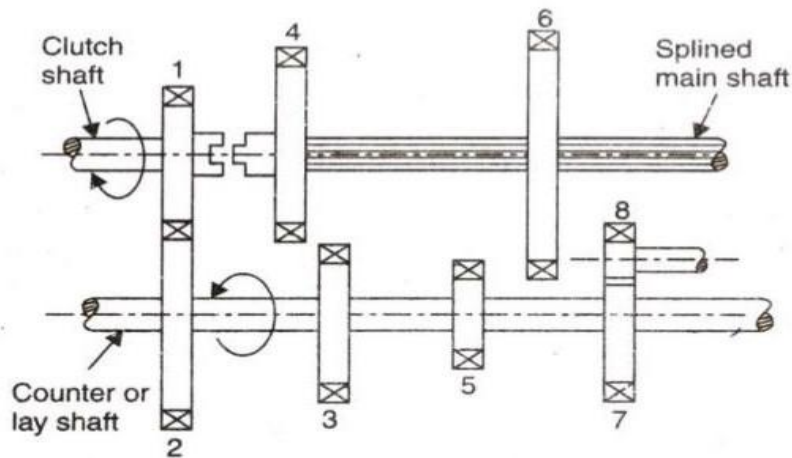

#### First Gear

- a) By operating gearshift lever, the larger gear on main shaft is made to slide and mesh with first gear of countershaft.
- b) The main shaft turns in the same direction as clutch shaft in the ratio of 3:1.

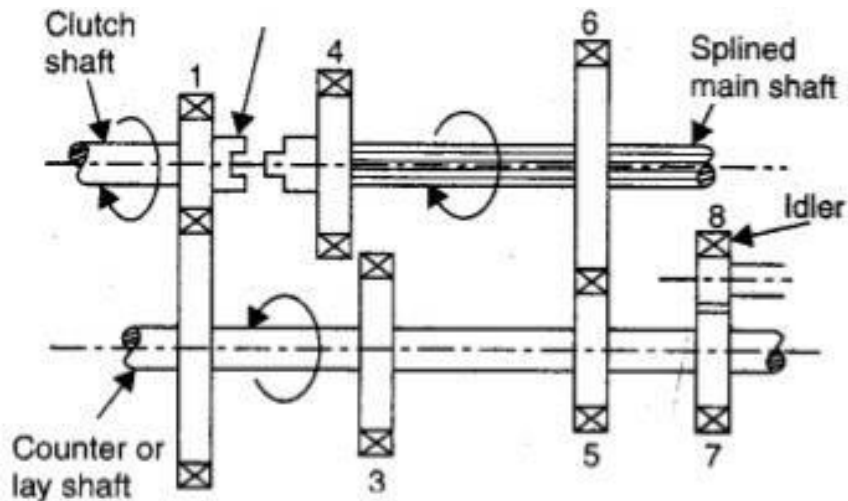

## Second Gear

- By operating gear shift lever, the smaller gear on the main shaft is made to slide and mesh with second gear of counter shaft.
- A gear reduction of approximately 2:1 is obtained.

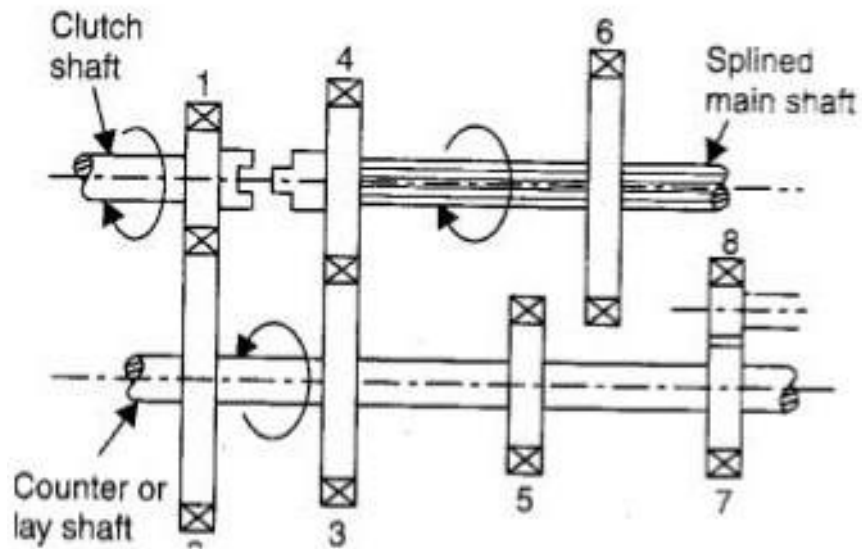

## Top Gear

- By operating gear shift lever, the combined second speed gear and top speed gear is forced axially against clutch shaft gear.
- External teeth on clutch gear mesh with internal teeth on top gear and the gear ratio is 1:1.

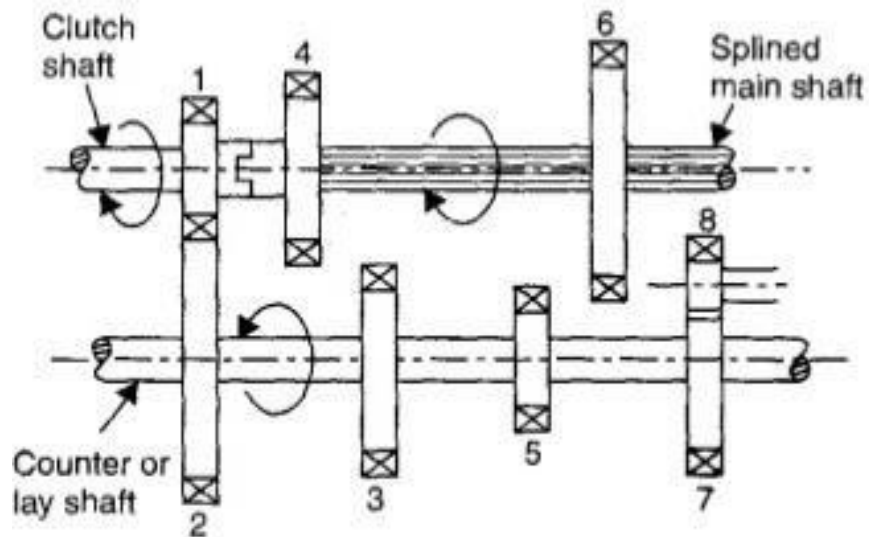

## Reverse Gear

- a) By operating gearshift lever, the larger gear of main shaft is meshed with reverse idler gear.
- b) The reverse idler gear is always on the mesh with counter shaft reverse gear. Interposing the idler gear, between reverse and main shaft gear, the main shaft turns in a direction opposite to clutch shaft.

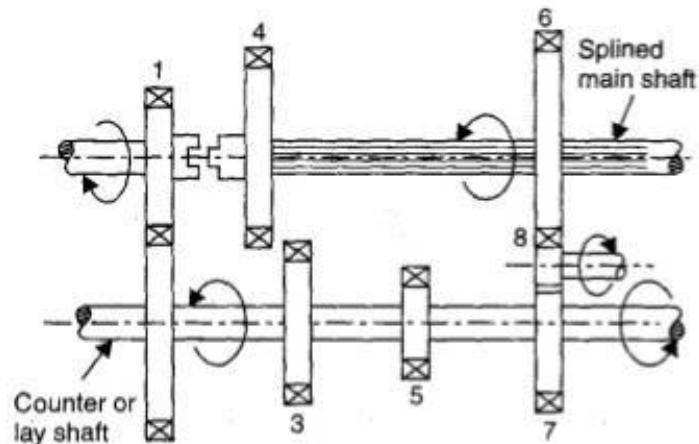

## Neutral Gear

- a) When engine is running and the clutch is engaged, clutch shaft gear drives the drive gear of the lay shaft and thus lay shaft also rotates.
- b) But the main shaft remains stationary as no gears in main shaft are engaged with lay shaft gears.

## CONSTANT MESH GEAR BOX

- a) In this type of gearbox, all the gears of the main shaft are in constant mesh with corresponding gears of the countershaft.
- b) The gears on the main shaft which are bushed are free to rotate.
- c) The dog clutches are provided on main shaft.
- d) The gears on the lay shaft are, however, fixed.
- e) When the left Dog clutch is slide to the left by means of the selector mechanism, its teeth are engaged with those on the clutch gear and we get the direct gear.
- f) The same dog clutch, however, when slide to right makes contact with the second gear and second gear is obtained.
- g) Similarly movement of the right dog clutch to the left results in low gear and towards right in reverse gear. Usually the helical gears are used in constant mesh gearbox for smooth and noiseless operation.

## Constant Mesh Gearbox

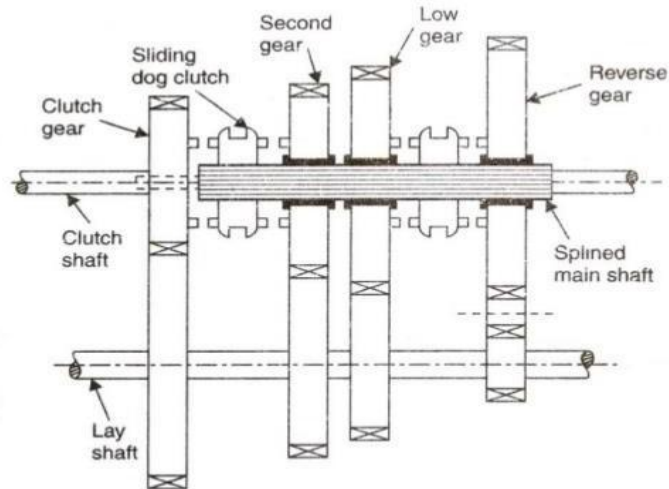

### Advantage over sliding mesh gear box

- Helical and herringbone gear can be used in these gear boxes and therefore, constant mesh gearboxes are quieter.
- Since the gears are engaged by dog clutches, if any damage occurs while engaging the gears, the dog unit members get damaged and not the gear wheels.

### Double declutching

- Used for smooth downshifting.

## SYNCHROMESH GEARBOX

This type of gearbox is similar to the constant mesh type gear box.

- a) Instead of using dog clutches here synchronizers are used.
- b) The modern cars use helical gears and synchromesh devices in gearboxes, that synchronize the rotation of gears that are about to be meshed

# Synchromesh Gearbox

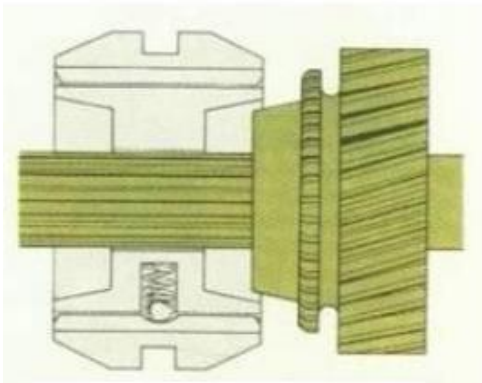

spring loaded balls hold the collar together

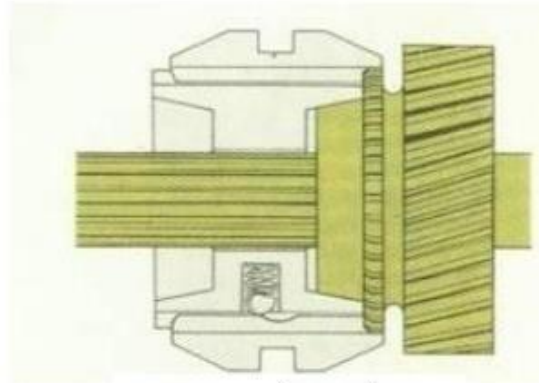

pressure on the gear lever causes toothed outer ring to slide into engagement

## Synchromesh Gearbox

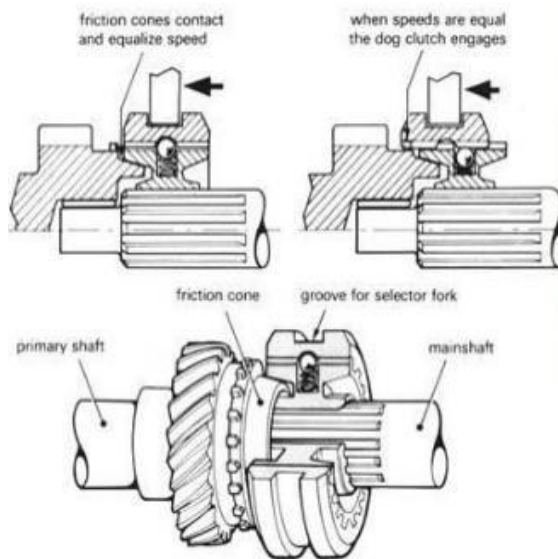

### SYNCHRONIZERS

- This type of gearbox is similar to the constant mesh type in that all the gears on the main shaft are in constant mesh with the corresponding gears on the lay shaft.
- The gears on the lay shaft are fixed to it while those on the main shaft are free to rotate on the same.
- Its working is also similar to the constant mesh type, but in the former there is one definite improvement over the latter.
- This is the provision of synchromesh device which avoids the necessity of double-declutching.
- The parts that ultimately are to be engaged are first brought into frictional contact,



which equalizes their speed, after which these may be engaged smoothly.

- f) Figure shows the construction and working of a synchromesh gearbox. In most of the cars, however, the synchromesh devices are not fitted to all the gears as is shown in this figure.
- g) They are fitted only on the high gears and on the low and reverse gears ordinary dog clutches are only provided.
- h) This is done to reduce the cost.

**Note:-**

The Model Gear Box Is Synchromesh Gear Box with 3 Forward and Single Reverse Gear.

Some Other Transmission Used In Modern Automobile

**1. TRANSFER CASE**

- Normally used in 4 wheel drive vehicles.
- Two speed transmission having „low and high“ rear ratios that can be engaged while in neutral position.
- Fixed after the gear box.
- Enables engagement and disengagement of 4 wheel drive.

**2. TRANSAXLE GEAR BOX**

- Have only 2 shafts.
- Used in vehicle with engine and drive on some side.
  - Front engine front wheel drive.
  - Rear engine rear wheel drive.
- Most commonly used.
- Gear box and differential in same housing.
- Combination of transmission and differential in one unit is called transaxle.
- Transaxles are both automatic and manual.

# Transaxles

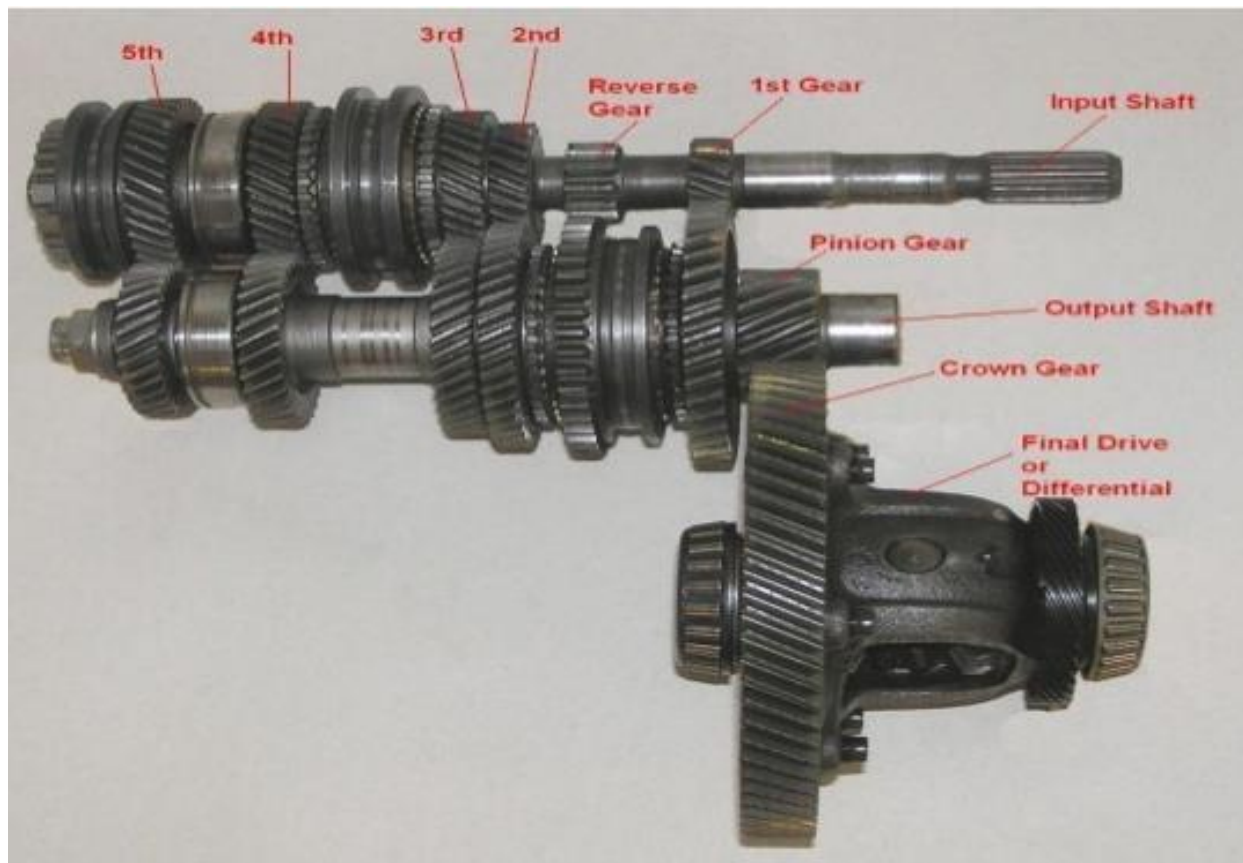

### 3. SEQUENTIAL GEAR BOX

- Manual transmission used the standard “H” pattern in the shifter.
- The manual transmission in a motorcycle is different. In a motorcycle, gear are shifted by clicking a lever up or down with toe/heel. It is much faster way to shift. This type of transmission is called a sequential gearbox or a sequential manual transmission.
- The only different is the way the control rods are manipulated the “H” pattern is eliminated and replaced with a different motion.
- Fool proof system- impossible to select wrong gear
- Race cars used sequential gear boxes.

#### Sequential Gearbox

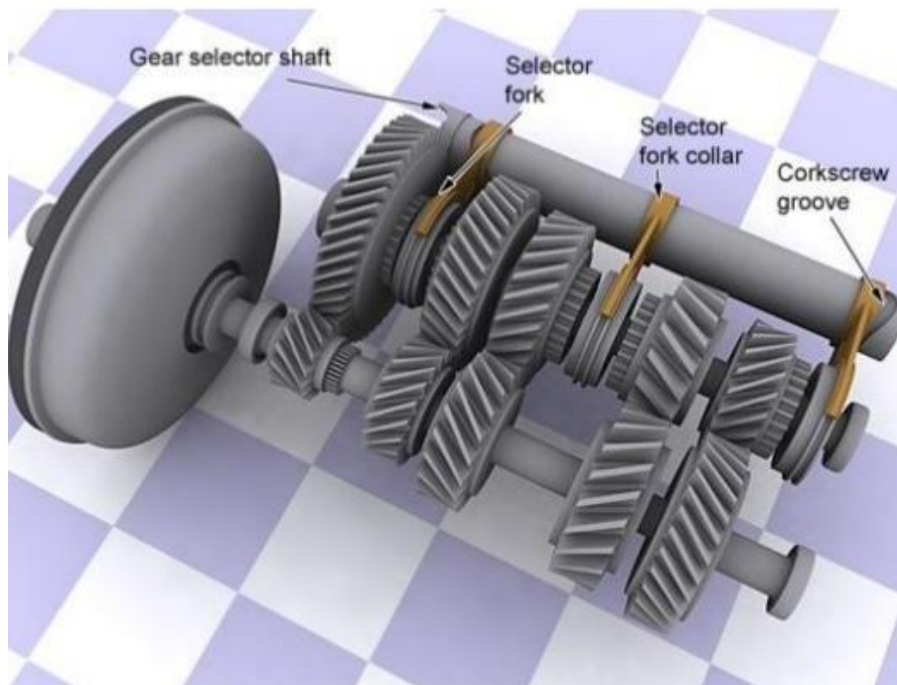



#### **4. CONTINUOUSLY VARIABLE TRANSMISSION**

- The continuously variable transmission (CVT) is transmission in which the ratio of the rotation speed of two shafts, as the input shafts and output shaft of a vehicle or other machine, can be varied continuously within a given range, providing an infinite num. of possible ratios.
- CVT allows the relationship between the speed of the engine and the speed of the wheels to be selected within a continuous range rather than in steps.
- This provides even better fuel economy if the engine is constantly running at a single speed
- The transmission provides better user experience without much rise and falls in speed of and engine, and eliminated the jerk felt when changing gears.

## Continuously Variable Transmission

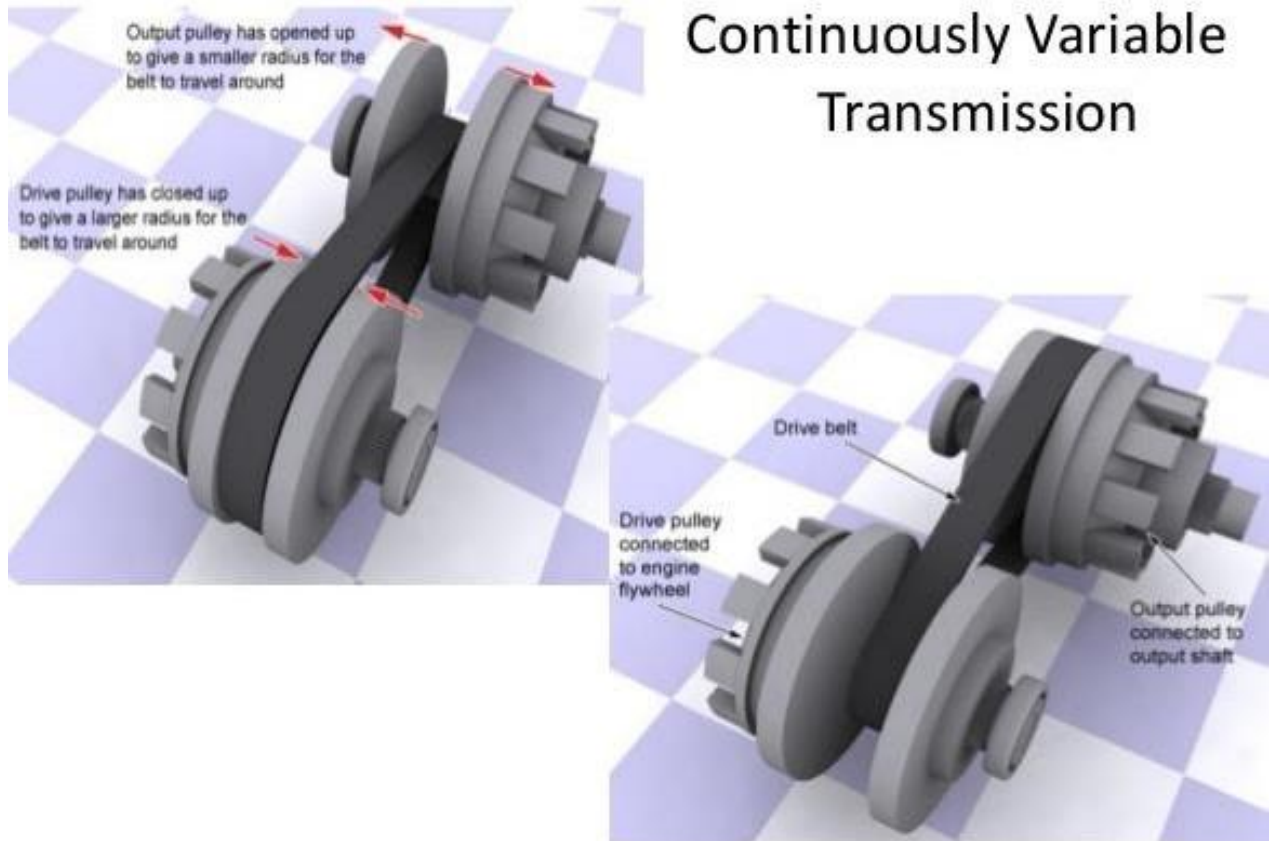

### 5. EPICYCLE GEARBOX

Epicycle Gearing or planetary gearing are used in an automatic transmission. An automatic transmission will select an appropriate gear ratio without any operator intervention.

They primarily used hydraulics to select gear, depending on pressure exerted by fluid within the transmission assembly.

Rather than using a clutch to engage the transmission, a fluid flywheel, or torque converter is placed in between the engine and transmission.

It is possible for the driver to control the no. of gear in use or select reverses, through precise control of which gear is in use may or may not be possible.

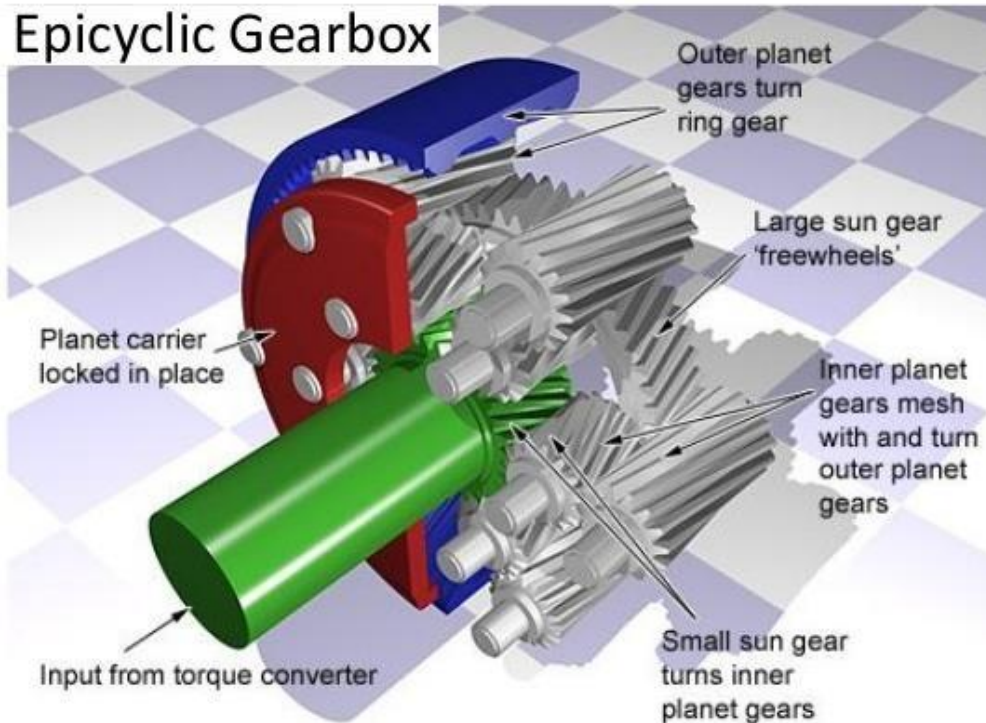

### WORKING

- If the car is in overdrive (on a four speed transmission), the transmission will automatically select the gear based on vehicle speed and throttle pedal position.
- When we accelerate gently, shifts will occur at lower speeds than if we accelerate at full throttle.
- When we floor the pedal, the transmission will downshift to the next lower gear.
- When we move the shift selector to a lower gear, the transmission will downshift unless the car is going too fast for that gear. If the car is going too fast, it will wait until the car slows down and then downshift.
- When we put the transmission in second gear, it will never downshift or upshift out of second, even from a complete stop, unless we move the shift lever.

### ADVANTAGES OVER MANUAL TRANSMISSION

- No loss of torque transmission from the engine to the driving wheels during gear shifts.
- Very smooth gear-shift operations.
- Appeals to drivers due to overall fast shifts and rapid responses, along with the latest technology.

### DISADVANTAGES OVER MANUAL TRANSMISSION

- Mechanical efficiency is less than that of a manual transmission type.
- It requires a specialized transmission fluid which is expensive and needs to be changed regularly.
- It is expensive to manufacture.
- It is heavier than a conventional manual transmission gear box.
- It has a much higher rate of failure due to complexity.

## **DIFFERENTIAL GEAR OF AN AUTOMOBILE:**

The differential gear used in the rear drive of an automobile is shown in Fig. 13.21. Its function is

- (a) to transmit motion from the engine shaft to the rear driving wheels, and
- (b) to rotate the rear wheels at different speeds while the automobile is taking a turn

As long as the automobile is running on a straight path, the rear wheels are driven directly by the engine and speed of both the wheels is same. But when the automobile is taking a turn, the outer wheel will run faster than the \* inner wheel because at that time the outer rear wheel has to cover more distance than the inner rear wheel. This is achieved by epicyclic gear train with bevel gears as shown in Fig. 13.21.

The bevel gear *A* (known as pinion) is keyed to the propeller shaft driven from the engine shaft through universal coupling. This gear *A* drives the gear *B* (known as crown gear) which rotates freely on the axle *P*. Two equal gears *C* and *D* are mounted on two separate parts *P* and *Q* of the rear axles respectively. These gears, in turn, mesh with equal pinions *E* and *F* which can rotate freely on the spindle provided on the arm attached to gear *B*.

When the automobile runs on a straight path, the gears *C* and *D* must rotate together. These gears are rotated through the spindle on the gear *B*. The gears *E* and *F* do not rotate on the spindle. But when the automobile is taking a turn, the inner rear wheel should have lesser speed than the outer rear wheel and due to relative speed of the inner and outer gears *D* and *C*, the gears *E* and *F* start rotating about the spindle axis and at the same time revolve about the axle axis.

Due to this epicyclic effect, the speed of the inner rear wheel decreases by a certain amount and the speed of the outer rear wheel increases, by the same amount. This may be well understood by drawing the table of motions as follows:

This difficulty does not arise with the front wheels as they are greatly used for steering purposes and are mounted on separate axles and can run freely at different speeds.

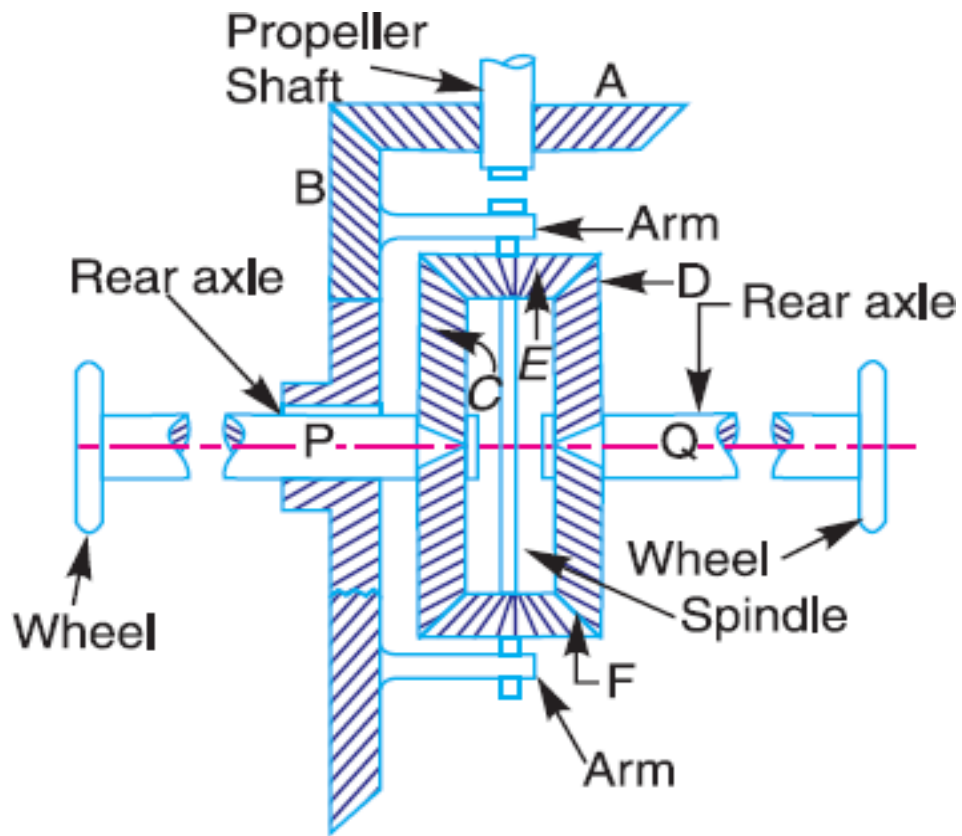

**Fig.** Differler gear of an automobile.

**RESULT:**

**VIVA QUESTIONS:**

- 1) Define addendum circle.
- 2) Define working depth.
- 3) State law of gearing.
- 4) What is Reverted gear train?
- 5) Define speed ratio of gear device.



## **EXPERIMENT NO. 11**

### **FREE AND FORCED VIBRATION OF CANTILEVER BEAM**

#### **AIM:**

- To study the forced vibration of the beam for different damping.

#### **APPARATUS:**

- Vibration test rig
- Cantilever Beam
- Rubber hammer

#### **THEORY:**

- In this experiment, a slightly heavy rectangular section bar is supported at both ends in trunion fittings. Exciter unit with the weight platform can be clamped at any conventional position along the beam. Exciter unit is connected to the damper. Which provides the necessary damping?

#### **DAMPING ARRANGEMENT:**

1. Close the one hole of damper for light damping.
2. Close the two holes of damper for medium damping.
3. Close all the three holes of damper for heavy damping.

#### **EXPERIMENTAL PROCEDURE:**

1. Arrange the setup
2. Connect the exciter motor to control panel.
3. Start the motor and allow the system to vibrate.
4. Wait for 5 minutes for amplitude to build up for particular forcing frequency.
5. Adjust the position of strip chart recorder. Take the recorder of amplitude vs. Time on strip chart recorder by starting recorder motor.
6. Take record by changing forcing frequency for each damping.
7. Repeat the experiment for different damping.

#### **GRAPH:**

- Plot the graph of amplitude Vs. Frequency for each damping

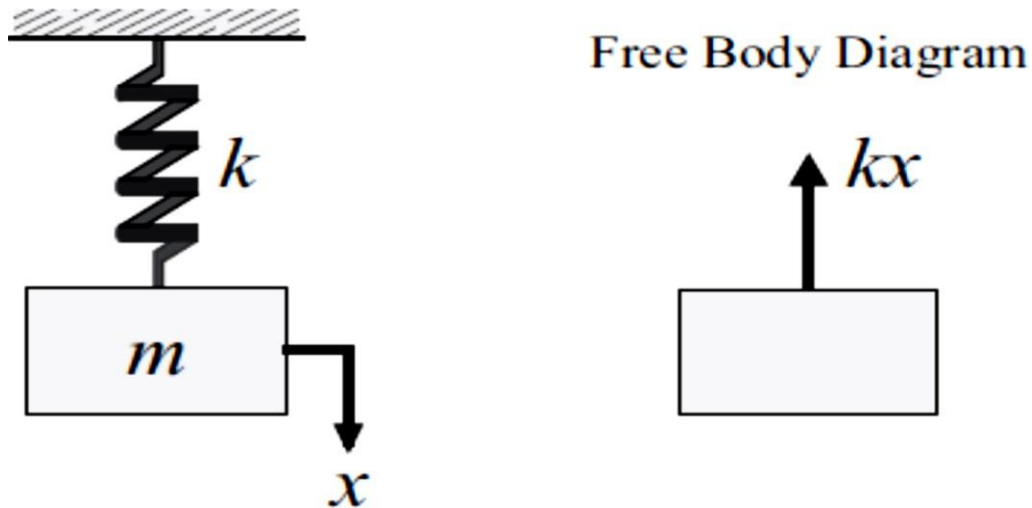

Figure. Spring-Mass System

**OBSERVATION TABLE:**

S. NO.	FORCING FREQUENCY	AMPLITUDE
1		
2		
3		

**PRECAUTIONS:**

- 1) Do not run the motor at low voltage i.e. less than 180 volts.
- 2) Do not increase the speed at once.
- 3) Damper is always in perpendicular direction.
- 4) A motor bolts is properly tightly with weight.
- 5) A beam is proper tight in bearing with bolt.
- 6) Always keep the apparatus free from dust.

**RESULT:**

**VIVA QUESTIONS:**

- 1) Define free vibrations.
- 2) Define forced vibrations.
- 3) Define torsional vibrations.
- 4) Define longitudinal vibrations.
- 5) Define frequency related to vibratory motion.