

THERMAL ENGINEERING LAB

LAB MANUAL

Subject Code : AME113
Regulations : R16
Class : III Year I Semester

Mr. P. Sadanandam
Asst. Professor



Department of Mechanical Engineering

INSTITUTE OF AERONAUTICAL ENGINEERING

Dundigal – 500 043, Hyderabad



INSTITUTE OF AERONAUTICAL ENGINEERING

Dundigal, Hyderabad - 500 043

MECHANICAL ENGINEERING

Program Outcomes	
PO1	Capability to apply the knowledge of mathematics, science and engineering in the field of mechanical engineering.
PO2	An ability to analyze complex engineering problems to arrive at relevant conclusion using knowledge of mathematics, science and engineering.
PO3	Competence to design a system, component or process to meet societal needs within realistic constraints.
PO4	To design and conduct research oriented experiments as well as to analyze and implement data using research methodologies.
PO5	An ability to formulate solve complex engineering problem using modern engineering and information Technology tools.
PO6	To utilize the engineering practices, techniques, skills to meet needs of the health, safety, legal, cultural and societal issues.
PO7	To understand impact of engineering solutions in the societal context and demonstrate the knowledge for sustainable development.
PO8	An understanding and implementation of professional and ethical responsibilities.
PO9	To function as an effective individual and as a member or leader in multi disciplinary environment and adopt in diverse teams.
PO10	An ability to assimilate, comprehend, communicate, give & receive instructions to present effectively with engineering community and society.
PO11	An ability to provide leadership in managing complex engineering projects at multidisciplinary environment and to become a Technocrat.
PO12	Recognition of the need and an ability to engage in lifelong learning to keep abreast with technological changes.
Program Specific Outcomes	
PSO1	To produce engineering professional capable of synthesizing and analyzing mechanical systems including allied engineering streams.
PSO2	An ability to adopt and integrate current technologies in the design and manufacturing domain to enhance the employability.
PSO3	To build the nation, by imparting technological inputs and managerial skills to become technocrats.

THERMAL ENGINEERING LAB SYLLABUS

Exp. No.	Experiment	Page	
1	VALVE TIMING DIAGRAM	6	
2	PORT TIMING DIAGRAM	10	
3	IC ENGINE PERFORMANCE TEST FOR 4 STROKE S I ENGINE	14	
4	IC ENGINE PERFORMANCE TEST FOR 2 STROKE S I ENGINE	20	
5	IC ENGINE MORSE REATRDTATION MOTORING TESTS	25	
6	I C ENGINE HEAT BALANCE –S I ENGINE	32	
7	I C ENGINE ECONOMICAL SPEED TESTONS I ENGINE	38	
8	HEAT BALANCE TEST ON DIESEL ENGINE	44	
9	HEAT BALANCE TEST ON DIESEL ENGINE	51	
10	PERFORMANCE TEST ON VARIABLE COMPRESSION RATIO ENGINE	56	
11	VOLUMETRIC EFFICIENCY OF A RECIPROCATING AIR COMPRESSOR	63	
12	ASSEMBLYING AND DIS ASSEMBLYING IC ENGINE	69	
13	STUDY OF BOILERS	74	
Content Beyond Syllabi			
1	STUDY OF TURBO JET		
2	PERFORMANCE OF CENTRIFUGAL AND AXIAL FLOW COMPRESSORS		

ATTAINMENT OF PROGRAM OUTCOMES & PROGRAM SPECIFIC OUTCOMES

Exp. No.	Experiment	Program Outcomes Attained	Program Specific Outcomes Attained
1	VALVE TIMING DIAGRAM	PO1, PO2, PO3, PO5	PSO1, PSO2
2	PORT TIMING DIAGRAM	PO1, PO2, PO3, PO5	PSO1, PSO2
3	IC ENGINE PERFORMANCE TEST FOR 4 STROKE S I ENGINE	PO1, PO2, PO3, PO5	PSO1, PSO2
4	IC ENGINE PERFORMANCE TEST FOR 2 STROKE S I ENGINE	PO1, PO2, PO3, PO5	PSO1, PSO2
5	IC ENGINE MORSE REATR DATION MOTORING TESTS	PO1, PO2, PO3, PO5	PSO1, PSO2
6	I C ENGINE HEAT BALANCE –S I ENGINE	PO1, PO2, PO3, PO5	PSO1, PSO2
7	I C ENGINE ECONOMICAL SPEED TESTONS I ENGINE	PO1, PO2, PO3, PO5	PSO1, PSO2
8	HEAT BALANCE TEST ON DIESEL ENGINE	PO1, PO2, PO3, PO5	PSO1, PSO2
9	HEAT BALANCE TEST ON DIESEL ENGINE	PO1, PO2, PO3, PO5	PSO1, PSO2
10	PERFORMANCE TEST ON VARIABLE COMPRESSION RATIO ENGINE	PO1, PO2, PO3, PO5	PSO1, PSO2
11	VOLUMETRIC EFFICIENCY OF A RECIPROCATING AIR COMPRESSOR	PO1, PO2, PO3, PO5	PSO1, PSO2
12	ASSEMBLYING AND DIS ASSEMBLYING IC ENGINE	PO1, PO2, PO3, PO5	PSO1, PSO2
13	STUDY OF BOILERS	PO1, PO2, PO3, PO5	PSO1, PSO2
Content Beyond Syllabi			
1	STUDY OF TURBO JET	PO1, PO2, PO3, PO5	PSO1, PSO2
2	PERFORMANCE OF CENTRIFUGAL AND AXIAL FLOW COMPRESSORS		

THERMAL ENGINEERING LAB

OBJECTIVE:

In this laboratory, students will have the opportunity to study the working principle of IC engines (both SI and CI engines), performance and characteristics in terms of heat balancing, economical speed variations, air fuel ratio influence on the engine to reinforce classroom theory by having the student perform required tests, analyze subsequent data, and present the results in a professionally prepared report.

The machines and equipment used to determine experimental data include cut models of 4stroke diesel engine, 2stroke petrol engine, 4stroke and two stroke petrol engines with required specifications, Multi cylinder SI engine, Single cylinder Diesel engine for performance and speed test which is suitable to tests on variable compression ratios.

OUTCOMES:

Upon the completion of Mechanics I of Solids practical course, the student will be able to:

1. Determine the valve timing diagram of SI engine & CI engine.
2. Analyze the influence of variations in TDC and BDC operations
3. Calculate the IP, BP, brake thermal efficiency.
4. Calculate & Compare the performance characteristics.
5. Experiment on IC engine load variations with Air fuel ratio.
6. Apply the concept of Morse test on SI engine.(multi cylinder).
7. Analyse the efficiency of reciprocating air compressor
8. Determine the principle of various parameters in boilers.

EXPERIMENT NO: 1 VALVE TIMING DIAGRAM

AIM:

The experiment is conducted to

- Determine the actual valve timing for a 4-stroke diesel engine and hence draw the diagram.

DATA:ENGINE- *4stroke, single cylinder, constant speed, and water cooled vertical diesel engine, 5BHP, and 1500rpm.*

THEORY:

In a four stroke engine opening and closing of valves and fuel injection do not take place exactly at the end of dead center positions. The valves open slightly earlier and close after that respective dead center position. The injection (ignition) also occurs prior to the full compression and the piston reaches the dead Centre position. All the valves operated at some degree on either side in terms of crank angles from dead center position.

INLET VALVE:

During the suction stroke the inlet valve must be open to admit charge into the cylinder, the inlet valve opens slightly before the piston starts downward on the suction stroke.

The reason that the inlet valve is open before the start of suction stroke is that the valve is necessary to permit this valve to be open and close slowly to provide quite operations under high speed condition.

INLET VALVE OPENS (IVO):

It is done at 10 to 25° in advance of TDC position.

INLET VALVE CLOSES (IVC):

It is done at 25 to 50° after BDC position.

EXHAUST VALVE:

As the piston is forced out on the outstroke by the expanding gases, it has been found necessary to open the exhaust valve before the piston reaches the end of the stroke. By opening the exhaust valve before the piston reaches the end of its own power stroke, the gases have an outlet for expansion and begin to rush out of their own accord. This removes the greater part of the burnt gases reducing the amount of work to be done by the piston on its return stroke.

EXHAUST VALVE OPENS (EVO):

It is done at 30 to 50° in advance of BDC position.

EXHAUST VALVE CLOSES (EVC):

It is done at 10 to 15° after the TDC position.

PROCEDURE:

1. Keep the decompression lever in vertical position.
2. Bring the TDC mark to the pointer level closed.
3. Rotate the flywheel till the inlet valves moves down i.e., opened.
4. Draw a line on the flywheel in front of the pointer and take the reading.
5. Continue to rotate the flywheel till the inlet valve goes down and comes to horizontal position and take reading.
6. Continue to rotate the flywheel till the outlet valve opens, take the reading.
7. Continue to rotate the flywheel till the exhaust valve gets closed and take the reading.



3 Stroke Diesel Engine

OBSERVATIONS:

Sl. No.	Valve Position	Arc Length, S		Angle 'θ' in degrees
		cm	Mm	
1	TDC – Inlet Valve open			
2	BDC – Inlet Valve Close			
3	TDC – Exhaust Valve Open			
4	BDC – Exhaust Valve Close			

CALCULATIONS:

1. Diameter of the flywheel, D

$$D = \frac{\text{Circumference of the flywheel}}{\pi}$$

2. Angle 'θ' in degrees,

$$\theta = \frac{S \times 360}{D \times \pi}$$

Where,

S = Arc length, mm

RESULT:

Valve Timing diagram is drawn

PRE LAB QUESTIONS

1. Differentiate valve and port?
2. Define valve timing?.
3. Explain the importance of valve timing?
4. Define mechanism of valve operation?
5. Define the cam mechanism in IC engine?
6. Define crank mechanism?

POST LAB QUESTIONS

1. What is the position of inlet valve opening and closing?
2. What are the exhaust valve opening and closing positions?
3. Indicate the ignition period in the diagram?

EXPERIMENT NO: 2 **PORT TIMING DIAGRAM**

AIM:

The experiment is conducted to

- Determine the actual PORT timing for a 2-stroke Petrol engine and hence draw the diagram.

DATA: Engine: 2stroke single cylinder, constant speed, water cooled, vertical diesel engine, 5 BHP, 1500rpm.

THEORY: Here in this type of engine ports which take charges and remove exhaust are in the cylinder itself. By virtue of piston when the piston moves inside the cylinder it closes and opens ports. Here in this type of engine (two strokes) one revolution of crank shaft complete one cycle.

INLET PORT:

1. It is uncovered 45 to 50° in advance of TDC.
2. It is covered 40 to 45° after BDC.

EXHAUST PORT:

1. It is uncovered 40 to 45° in advance of BDC.
2. It is covered 40 to 55° after the TDC

TRANSFER PORT:

1. It is uncovered 35 to 45° in advance of BDC.
2. It is covered 35 to 45° after the BDC.

PROCEDURE:

1. Identify the ports.
2. Find out the direction of rotation of the crank shaft.
3. Mark the TDC and BDC positions on the flywheel.
4. Mark the openings and closings of the inlet exhaust and transverse ports.
5. Using a rope or thread and scale, find out the circumference of the flywheel.
6. Find out the arc lengths of the events IPO, IPC, EPO, EPC, TPO and TPC.
7. Let the arc length be Xcm.
Then angle $q = \frac{360 \times X}{2\pi R}$ Where R is the radius of the flywheel.
8. Draw the flywheel diagram with the help of four angles calculated from lengths.



Port Timing Diagram

OBSERVATIONS:

Sl. No	Event	Position of the crank	Arc distance from nearest dead center(cm)	Angle degree
1	IPO	BTDC		
2	IPC	ATDC		
3	TPO	BBDC		
4	TPC	ABDC		
5	EPO	BBDC		
6	EPC	ABDC		

Circumference of the fly wheel= 53cm

RESULT:

Sl.no	Event	Position of the crank	Arc distance from nearest dead center (cm)	Angle degree
1	IPO	BTDC		
2	IPC	ATDC		
3	TPO	BBDC		
4	TPC	ABDC		
5	EPO	BBDC		
6	EPC	ABDC		

PRE LAB QUESTIONS

1. Differentiate valve and port?
2. Define port timing?.
3. Explain the importance of port timing?
4. Define mechanism of port operation?
5. Define the air fuel mixing process in IC engine?
6. Define crank mechanism?

POST LAB QUESTIONS

- 1 .What are the position of inlet port opening and closing?
2. What are the transfer port opening and closing positions?
3. Indicate the exhaust port opening and closing position?

EXPERIMENT NO: 3

PERFORMANCE TEST FOR 4 STROKE S I ENGINE

INTRODUCTION:

The Test Rig is multicylinder petrol engine coupled to a hydraulic brake and complete with all measurement systems, auto electrical panel , self-starter assembly, Morse test setup, battery etc., Engine is with 4 cylinder water cooled radiator is provided. Engine cooling is done by through continuous flowing water.

SPECIFICATIONS:

- 1 Engine coupled to hydraulic brake
2. Clutch arrangement
3. Morse test setup
4. Stand, Panel with all measurements
5. Air tank, fuel tank
6. Auto electrical with battery

DESCRIPTION OF THE APPARATUS:

Engine: Either PREMIERE / AMBASSODAR four cylinder four stroke water cooled automotive (reclaim) spark ignited with all accessories.

Make: PREMIERE

Speed: max 5000rpm

Power: 23 HP at max speed

No of cylinders: FOUR

Firing order: 1-3-4-2

Cylinder bore: 73mm

Stroke length: 70mm

Spark plug gap: 0.64mm

Other components include battery, starter motor, alternator/DC dynamo, ignition switch, solenoid, cables, accelerator assembly, radiator, valves etc.

HYDRAULIC BRAKE:

It is a reaction type hydraulic dynamometer; a stator body can swing in its axis, depending upon the torque on the shaft. The shaft is extended at both ends and supported between two bearings. Rotor is coupled at one end to the engine shaft. Water is allowed inside through stator and flows inside pockets of rotor and comes out of rotor. Any closure of valve or any restriction of flowing water, created braking effect on the shaft, and which is reflected in opposition force of stator. Stator while reacting to proportional force pulls a spring balance, which is calibrated in kgs. Controlling all three valves enables to increase or decrease the load on the engine.

CLUTCH ARRANGEMENT:

A long lever with locking facility is provided. It helps to either couple engine to hydraulic brake or decouple both. Initially for no load do not couple these two and after increasing engine speed slowly engage same. Do not allow any water to dynamometer when engine is started. This is no load reading.

OBSERVATIONS:

1. Orifice diameter	d_0	=25mm
2. Density of water	ρ_w	=1000kg/m ³
3. Density of air	ρ_a	=1.2kg/m ³
4. Density of Petrol	ρ_f	=0.7kg/lit
5. Acceleration due to gravity	g	=9.81m/sec ²
6. Torque on length	R	=0.3mt
7. Calorific value of Petrol	C_v	=43,210kJ/kg
8. Cd of orifice		= 0.62
9. Cylinder bore	D	=73mm
10. Stroke length	L	=70mm

AIM:

The experiment is conducted to

- To study and understand the performance characteristics of the engine.
- To draw Performance curves and compare with standards.

PROCEDURE:

- Check the lubricating oil level.
- Check the fuel level.
- Check and Release the load on the dynamometer if loaded.
- Check the necessary electrical connections and switch on the Panel.
- Provide the Battery Connections.
- Open water valve for engine cooling and adjust flow rate , say 4to 6 LPM

CONSTANT SPEED TEST:

- After engine picks up speed slowly, engage clutch, now engine is coupled with hydraulic dynamometer.
- With the help of accelerator, increase engine to say 1500rpm.
- Note down the time required for 10litres of water flow, time required for 10cc of fuel, manometer reading, spring balance reading, all temperatures.
- For next load allow more water into dynamometer and also adjust throttle valve such that engine is loaded but with same RPM, 1500rpm.
- Note down all readings.
- Repeat experiment for next higher load, max 8kw.

OPERATING DYNAMOMETER:

1. Inlet water Valveno1 (V1)-If knob is rotated clockwise LOAD is reduced, that means water entry is reduced.
2. If this V1 if rotated anticlock wise LOAD increased, here water is allowed into dynamometer-MORE the water into dynamometer MORE is LOAD.
3. Drain V2 if opened completely then load is reduced, if closed by rotating clockwise then LOAD is increased.
4. Overflow valve No.3(V3)-if closed then Load is increased, If opened then LOAD is reduced.
5. In this manner load has to be increased or decreased.



I C Engines Performance Test For 4 Stroke S I Engine

TABULAR COLUMN:

Sl. No.	Speed, rpm	Spring balance Wkg	Manometer Reading			Time for 10 cc of fuel collected,t sec
			h ₁ cm	h ₂ cm	H _w =(h ₁ ~h ₂)	

CALCULATIONS:

1. Area of Orifice $A_0 = (\pi/4) d_0^2$ sq.cm (d_0 is orifice diameter = 25mm=0.025m)

2. Head of Air $H_a = \frac{(h_1 - h_2) \times \rho_w}{\rho_a}$ in mts; $\rho_w = 1000 \text{ kg/cm}^3$

$\rho_a = 1.2 \text{ kg/cm}^3$, h_1 and h_2 in mts

3. Mass flow rate of Air M_a in kg/hr

$$M_a = A_0 \times C_d \times 3600 \times \rho_a \times \sqrt{2 \times g \times H_a} \quad \text{kg/hr}$$

4. Total fuel consumption TFC : in kg/hr

$$\text{TFC} = \frac{10 \times 3600 \times \rho_f}{t_1 \times 1000}$$

5. Brake Power BP in Kw

a. With hydraulic brake dynamometer (reaction type)

b. $\text{BP} = [2 \times \pi \times 9.81 \times N \times W \times R] / 60,000 \text{ kW}$

i. Where $R =$ Load arm length = 0.3mts

ii. $W =$ load shown on spring balance, kg

iii. $N =$ speed in rpm

6. Specific fuel consumption: SFC in Kg/Kw-hr

$$1. \text{ SFC} = \text{TFC} / \text{BP}$$

7. Air Fuel ratio : A/F

$$\text{A/F} = M_a / \text{TFC}$$

8. Brake Thermal efficiency

9. $\eta_{\text{bth}} = [\text{BP} / \text{TFC} \times \text{CV}] \times 100\%$,

10. Indicated Thermal efficiency

11. $\eta_{\text{ith}} = [\text{IP} / \text{TFC} \times \text{CV}] \times 100\%$,

GRAPHS:

Plot curves of BP vs. TFC, SFC, and A/F.

PRE LAB QUESTIONS:

1. What are the 4 strokes of SI engines?
2. What is the working cycle of SI Engine?
3. List out the performance parameters?
4. Indicate the different types of loads?
5. Differentiate SFC and TFC?
6. Concept of mass flow rate of air?

POST LAB QUESTIONS:

1. Differentiate brake power and indicated power?
2. Define brake thermal efficiency?
3. Indicate mechanical efficiency in terms of BP and IP?

EXPERIMENT NO: 4**IC ENGINES PERFORMANCE TEST FOR 2 STROKE S I ENGINE**

OBJECTIVE: To conduct LOAD TEST
 To calculate brake thermal efficiency
 To determine A/F ratio.

INTRODUCTION:

Test rig is with two stroke Bajaj make Petrol engine, coupled to Electrical dynamometer. Engine is air cooled type, hence only load test can be conducted at a constant speed of 3000rpm. Test rig is complete with base, air measurement, fuel measurement and temperature measurement system. Thermocouple is employed to measure temperature digitally.

Two stroke engines are coupled with ports closing at inlet and exhaust. Hence when compared to four stroke engine, it has low fuel efficiency because scavenging effect. But its construction and maintenance is easy, and costs less.

TEST SET UP:

01. Main chassis, engine coupled to dynamometer
02. Control desk with all measurements
03. Hoses, cables, thermocouples, misc.

CHASIS:

It is made from strong MS channels, with foundation facility. Support bracket, to hold by hand while kick starting the engine.

Engine:

Bajaj classic/Chetek

Two stroke, single cylinder, air cooled, petrol driven

Compression Ratio : 7.4:1

Ignition timing : Spark advance of 22 degree before TDC

Bore : 57 mm

Stroke length : 57 mm

Displacement : 145.45 cc

Observations:

1. Orifice diameter d_0 = 15.25mm
2. Density of water ρ_w = 1000kg/m³
3. Density of air ρ_a = 1.2kg/m³
4. Density of Petrol ρ_f = 0.7kg/lit
5. Acceleration due to gravity g = 9.81m/sec²
6. Alternator efficiency η_g = 70%
7. Calorific value of Petrol C_v = 43,210kJ/kg
8. Cd of orifice = 0.62
9. Cylinder bore D = 57mm
10. Stroke length L = 57mm

PROCEDURE:

1. Fill up water in manometer to required level
2. Ensure petrol level in the fuel tank.
3. Ensure engine oil.
4. Put MCB of alternator to ON, switch of all load banks or bring aluminum conductor of water loading rheostat above water level.
5. Add water
6. Switch ON ignition
7. Fix accelerator at some setting
8. Now kick start the engine and when it pickups speed adjust at 3000 rpm
9. at this no load note down manometer, speed ,temperature, voltage current and time for 10 cc of fuel consumption.
10. Repeat for different loads.

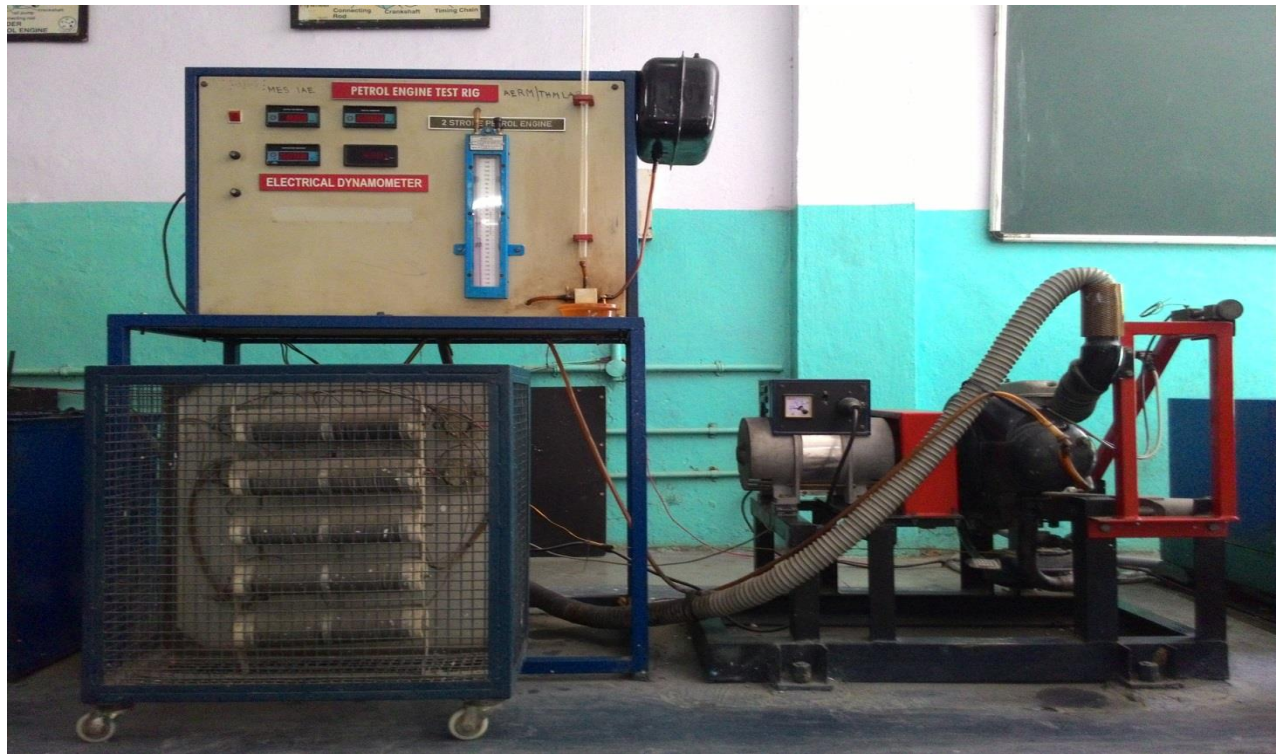

TABULAR COLUMN:

Sl. No.	Speed, rpm	Spring balance Wkg	Manometer Reading			Time for 10 cc offuel collected, t sec
			h ₁ cm	h ₂ cm	h _w = (h ₁ ~h ₂)	

CALCULATIONS:

1. Area of Orifice $A_0 = (\pi/4) d_0^2$ sq.cm (d_0 is orifice diameter = mm)

2. Manometer Head $H_a = \frac{(h_1 - h_2) \times \rho_w}{\rho_a}$ (in mts; $\rho_w = 1000 \text{ kg/cm}^3$

$\rho_a = 1.2 \text{ kg/cm}^3$, h_1 and h_2 in mts

3. Mass flow rate of Air M_a in kg/hr

$$M_a = A_0 \times C_d \times 3600 \times \rho_a \times \sqrt{2 \times g \times H_a} \text{ kg/hr}$$

4. Total fuel consumption TFC : in kg/hr

$$TFC = \frac{10 \times 3600 \times \rho_f}{t_1 \times 1000}$$

5. Brake Power BP in Kw

$$BP = \frac{VI}{\eta_g} \times 1000 \text{ kW}$$

6. Specific fuel consumption: SFC in Kg/Kw-hr

$$SFC = TFC/BP$$

7. Air Fuel ratio : A/F

$$A/F = M_a/TFC$$

8. Brake Thermal efficiency

$$\eta_{bth} = [BP/TFC \times CV] \times 100\%$$

GRAPHS:

Plot curves of BP vs. TFC, SFC, A/F,

PRECAUTIONS:

1. Do not allow speed above 3000 rpm
2. Don't increase load above 8 Amps
3. Don't run engine without engine oil
4. Mix petrol and 2T oil at 1 liter.

PRE LAB QUESTIONS:

1. What are the 2 strokes of SI engines?
2. What is the working cycle of SI Engine?
3. List out the performance parameters?
4. Indicate the different types of loads?
5. Differentiate SFC and TFC?
6. Concept of mass flow rate of air?

]

POST LAB QUESTIONS:

1. Differentiate brake power and indicated power?
2. Define brake thermal efficiency?
3. Indicate mechanical efficiency in terms of BP and IP?

EXPIREMENT: 5

IC ENGINE MORSE REATRDIATION MOTORING TESTS

AIM:

To Conduct Morse test to determine frictional power
To conduct motoring test

INTRODUCTION:

The Test Rig is multi cylinder petrol engine coupled to a hydraulic brake and complete with all measurement systems, auto electrical panel , self-starter assembly, Morse test setup, battery etc., Engine is with 4 cylinder water cooled radiator is provided. Engine cooling is done by through continuous flowing water.

SPECIFICATIONS:

1. Engine coupled to hydraulic brake
2. Clutch arrangement
3. Morse test setup
4. Stand, Panel with all measurements
5. Air tank, fuel tank
6. Auto electrical with battery

DESCRIPTION OF THE APPARATUS:

Engine : Either PREMIERE / AMBASSODAR four cylinder four stroke water cooled automotive (reclaim) spark ignited with all accessories.

Make : PREMIERE

Speed : max 5000rpm

Power : 23 HP at max speed

No of cylinders : FOUR

Firing order : 1-3-4-2

Cylinder bore : 73mm

Stroke length : 70mm

Spark plug gap : 0.64mm

Other components include battery, starter motor, alternator/DC dynamo, ignition switch, solenoid, cables, accelerator assembly, radiator, valves etc.

HYDRAULIC BRAKE:

It is a reaction type hydraulic dynamometer; a stator body can swing in its axis, depending upon the torque on the shaft. The shaft is extended at both ends and supported between two bearings. Rotor is coupled at one end to the engine shaft. Water is allowed inside through stator and flows inside pockets of rotor and comes out of rotor. Any closure of valve or any restriction of flowing water, created breaking effect on the shaft, and which is reflected in opposition force of stator. Stator while reacting to proportional force pulls a spring balance, which is calibrated in kgs. Controlling all three valves

enables to increase or decrease the load on the engine.

CLUTCH ARRANGEMENT:

A long lever with locking facility is provided. It helps to either couple engine to hydraulic brake or decouple both. Initially for no load do not couple these two and after increasing engine speed slowly engage same. Do not allow any water to dynamometer when engine is started. This is no load reading.

OBSERVATIONS:

- | | |
|------------------------------------|-------------------------|
| 1. Orifice diameter d_0 | =25mm |
| 2. Density of water ρ_w | =1000kg/m ³ |
| 3. Density of air ρ_a | =1.2kg/m ³ |
| 4. Density of Petrol ρ_f | =0.7kg/lit |
| 5. Acceleration due to gravity g | =9.81m/sec ² |
| 6. Torque on length R | =0.3mt |
| 7. Calorific value of Petrol C_v | =43,210kJ/kg |
| 8. Cd of orifice | = 0.62 |
| 9. Cylinder bore D | =73mm |
| 10. Stroke length L | =70mm |

CONSTANT SPEED TEST:

1. After engine picks up speed slowly, engage clutch, now engine is coupled with hydraulic dynamometer.
2. With the help of accelerator, increase engine to say 1500rpm.
3. Note down the time required for 10litres of water flow, time required for 10cc of fuel, manometer reading, spring balance reading, all temperatures.
4. For next load allow more water into dynamometer and also adjust throttle valve such that engine is loaded but with same RPM, 1500rpm.
5. Note down all readings.
6. Repeat experiment for next higher load, max 8kw.

OPERATING DYNAMOMETER:

1. Inlet water Valveno1 (V1)-If knob is rotated clockwise LOAD is reduced, that means water entry is reduced.
2. If this V1 if rotated anti clock wise LOAD increased, here water is allowed into dynamometer-MORE the water into dynamometer MORE is LOAD.
3. Drain V2 if opened completely then load is reduced, if closed by rotating clockwise then LOAD is increased.
4. Overflow valve No.3 (V3)-if closed then Load is increased, If opened then LOAD is reduced.
5. In this manner load has to be increased or decreased.

MORSE TEST:

Above procedure is repeated, with some load and speed say 1500rpm note down spring balance reading and exact RPM.

1. Cut OFF switch No.1, now for the same load, engine speed drops, regains the set. Speed without altering throttle, decrease the load by dynamometer now note down spring balance and speed readings.
2. Put ON switch No.1, and put OFF No 2 and adjust load to bring same speed.
3. Put ON switch No.2 and put OFF switch 3, repeat above step.
4. Put ON switch No.3 and put OFF switch 4 and repeat above step
5. Care should be taken that at a time more than two switches should not be put off.



I C Engine Morse Retardation Motoring Tests

TABULAR COLUMNS:

Sl. No.	Speed, rpm	Spring balance Wkg	Manometer Reading			Time for 10 cc of fuel collected, t sec
			h ₁ cm	h ₂ cm	h _w = (h ₁ ~h ₂)	

MORSE TEST:

Sl.No	Cylinders ON	Cylinders OFF	Load Kgs	Speed (N)rpm	BP
1					
2					
3					
4					
5					

CALCULATIONS:

1. Area of Orifice $A_0 = \frac{\pi}{4} d_0^2 \text{ cm}^2$ (d_0 is orifice diameter = 25mm=0.025m)

2. Head of Air $H_a = \frac{(h_1 - h_2) \times \rho_w}{\rho_a}$ (in mts; $\rho_w = 1000 \text{ kg/cm}^3$
 $\rho_a = 1.2 \text{ kg/cm}^3$, h_1 and h_2 in mts)

3. Mass flow rate of Air M_a in kg/hr

$$M_a = A_0 \times C_d \times 3600 \times \rho_a \times \sqrt{2 \times g \times H_a} \text{ kg/hr}$$

4. Total fuel consumption TFC : in kg/hr

$$\text{TFC} = \frac{10 \times 3600 \times \rho_f}{t_1 \times 1000}$$

5. Brake Power BP in Kw

a. With hydraulic brake dynamometer (reaction type)

b. $\text{BP} = [2 \times \pi \times 9.81 \times N \times W \times R] / 60,000 \text{ kW}$

Where R= Load arm length = 0.3mts

W= load shown on spring balance,kg

N= speed in rpm

6. Specific fuel consumption: SFC in Kg/Kw-hr

1. $\text{SFC} = \text{TFC} / \text{BP}$

7. Air Fuel ratio : A/F

$$\text{A/F} = \text{Ma} / \text{TFC}$$

8. Brake Thermal efficiency

$$\eta_{\text{bth}} = [\text{BP} / \text{TFC} \times \text{CV}] \times 100\%$$

With MORSE TEST:

a. Determine B, B1, B2, B3 and B4 – Brake powers as above

b. Indicated Power in kW , $\text{IP} = [4 \times B] - [B1 + B2 + B3 + B4] \text{ kW}$

c. Mechanical Efficiency $\eta_m = \text{BP} / \text{IP}$

9. 9. Indicated Thermal efficiency

$$\eta_{ith} = [IP/TFC \times CV] \times 100\%$$

GRAPHS:

Plot curves of BP vs. TFC, SFC, A/F, and Mechanical efficiency.

MOTORING TEST:

CALCULATIONS:

1. FRICTION POWER, FP

$$FP = (V \cdot I) / 1000 \text{ KW}$$

Where,

V = voltmeter reading on motoring side

I = ammeter reading on motoring side

PRE LAB QUESTIONS:

1. What are the 4 strokes of SI engines?
2. What is the working cycle of SI Engine?
3. List out the performance parameters?
4. Indicate the different types of loads?
5. Differentiate SFC and TFC?
6. What are the different methods to find frictional power?

POST LAB QUESTIONS:

1. Differentiate brake power and indicated power?
2. Define brake thermal efficiency?
3. Indicate mechanical efficiency in terms of BP and IP?
4. Explain the procedure for finding frictional power using Morse test?

EXPERIMENT NO: 6

I C ENGINE HEAT BALANCE –S I ENGINE

AIM: To conduct Heat Balance on S I Engine.

INTRODUCTION:

The Test Rig is multi cylinder petrol engine coupled to a hydraulic brake and complete with all measurement systems, auto electrical panel , self-starter assembly, Morse test setup, battery etc., Engine is with 4 cylinder water cooled radiator is provided. Engine cooling is done by through continuous flowing water.

Specifications:

1. Engine coupled to hydraulic brake
2. Clutch arrangement
3. Morse test setup
4. Stand, Panel with all measurements
5. Air tank, fuel tank
6. Auto electrical with battery

DESCRIPTION OF THE APPARATUS:

Engine: Either PREMIERE / AMBASSODAR four cylinder four stroke water cooled automotive (reclaim) spark ignited with all accessories.

Make	: PREMIERE
Speed	: max 5000rpm
Power	: 23 HP at max speed
No of cylinders	: FOUR
Firing order	: 1-3-4-2
Cylinder bore	: 73mm
Stroke length	: 70mm
Spark plug gap	: 0.64mm

Other components include battery, starter motor, alternator/DC dynamo, ignition switch, solenoid, cables, accelerator assembly, radiator, valves etc.

HYDRAULIC BRAKE:

It is a reaction type hydraulic dynamometer; a stator body can swing in its axis, depending upon the torque on the shaft. The shaft is extended at both ends and supported between two bearings. Rotor is coupled at one end to the engine shaft. Water is allowed inside through stator and flows inside pockets of rotor and comes out of rotor. Any closure of valve or any restriction of flowing water, created breaking effect on the shaft, and which is reflected in opposition force of stator. Stator while reacting to proportional force pulls a spring balance, which is calibrated in kgs. Controlling all three valves enables to increase or decrease the load on the engine.

CLUTCH ARRANGEMENT:

A long lever with locking facility is provided. It helps to either couple engine to hydraulic brake or decouple both. Initially for no load do not couple these two and after increasing engine speed slowly engage same. Do not allow any water to dynamometer when engine is started. This is no load reading.

Observations:

- 1. Orifice diameter d_0 =25mm
- 2. Density of water ρ_w =1000kg/m³
- 3. Density of air ρ_a =1.2kg/m³
- 4. Density of Petrol ρ_f =0.7kg/lit
- 5. Acceleration due to gravity g =9.81m/sec²
- 6. Torque on length R =0.3mt
- 7. Calorific value of Petrol C_v =43,210kJ/kg
- 8. Cd of orifice C_d = 0.62
- 9. Cylinder bore D =73mm
- 10. Stroke length L =70mm

OPERATING DYNAMOMETER:

- 1. Inlet water Valveno1 (V1)-If knob is rotated clockwise LOAD is reduced, that means water entry is reduced.
- 2. If this V1 if rotated anti clock wise LOAD increased, here water is allowed into dynamometer-MORE the water into dynamometer MORE is LOAD.
- 3. Drain V2 if opened completely then load is reduced, if closed by rotating clockwise then LOAD is increased.
- 4. Overflow valve No.3 (V3)-if closed then Load is increased, If opened then LOAD is reduced.
- 5. In this manner load has to be increased or decreased.

TABULAR COLUMN:

Sl. No.	Speed, rpm	Spring balance Wkg	Manometer Reading			Time for 10 cc of fuel collected, t sec
			h1 cm	h2 cm	$h_w = (h1-h2)$	

TEMPERATURE MEASUREMENT:

Sl. no	T1 room temp °C	T2 inlet water °C	T3 outlet water °C	T4 exhaust gases °C

CALCULATIONS:

1. Area of Orifice $A_0 = \frac{\pi}{4} d_0^2 \text{ cm}^2$ (d_0 is orifice diameter = 25mm=0.025m)

2. Head of Air $H_a = \frac{(h_1 - h_2) \times \rho_w}{\rho_a}$ (in mts; $\rho_w = 1000 \text{ kg/cm}^3$
 $\rho_a = 1.2 \text{ kg/cm}^3$, h_1 and h_2 in mts)

3. Mass flow rate of Air M_a in kg/hr

$$M_a = A_0 \times C_d \times 3600 \times \rho_a \times \sqrt{2 \times g \times H_a} \text{ kg/hr}$$

4. Total fuel consumption TFC : in kg/hr

$$\text{TFC} = \frac{10 \times 3600 \times \rho_f}{t_1 \times 1000}$$

5. Brake Power BP in Kw

a. With hydraulic brake dynamometer (reaction type)

b. $\text{BP} = [2 \times \pi \times 9.81 \times N \times W \times R] / 60,000 \text{ kW}$

Where R= Load arm length = 0.3mts

W= load shown on spring balance,kg

N= speed in rpm

6. Specific fuel consumption: SFC in Kg/Kw-hr

1. $\text{SFC} = \text{TFC} / \text{BP}$

7. Air Fuel ratio : A/F

$$\text{A/F} = \text{Ma} / \text{TFC}$$

8. Brake Thermal efficiency

$$\eta_{\text{bth}} = [\text{BP} / \text{TFC} \times \text{CV}] \times 100\%$$

Heat Balance Sheet Calculations in MINUTES basis:

A. Credit side:

Heat Input: H_i

$$H_i = \frac{\text{TFC} \times \text{CV}}{60} \text{ kJ/min}$$

B. Debit Side:

a. Heat converted into useful work H_b

$$H_b = \text{BP} \times 60 \text{ kJ/min}$$

b. Heat carried away by engine cooling water H_w

$$H_w = \frac{1 \times C_{pw} \times (T_3 - T_2)}{t_2} \times 60 \text{ kJ/min}$$

c. Heat carried away by exhaust gases

$$H_e = [M_e \times C_{pg} \times (T_4 - T_1)] \text{ kJ/min}$$

M_e = mass flow rate of exhaust gas in Kg/min

C_{pg} = specific heat of exhaust gas 1.005 kJ/KgK

$M_e = M_a + \text{TFC}$ in Kg/hr.

d. Un accountable losses:

$$H_u = [H_i] - \{H_b + H_w + H_e\} \text{ kJ/min}$$

HEAT BALANCE SHEET:

Credit Side (Input)				Debit Side (Out Put)			
Sl. No.	Particulars	Heat, Kj/Min	%	Sl. No.	Particulars	Heat, Kj/Min	%
	H_i				H_b		
					H_w		
					H_e		
					H_u		
Total:			100				100

PRE LAB QUESTIONS:

1. What are the 4 strokes of SI engines?
2. What is the working cycle of SI Engine?
3. List out the performance parameters?
4. Indicate the different types of loads?
5. Differentiate SFC and TFC?
6. What are the different heat losses in SI engines?

POST LAB QUESTIONS:

1. Differentiate brake power and indicated power?
2. Define brake thermal efficiency?
3. Explain different heat losses by using Sankey diagram?

EXPERIMENT NO: 07
I C ENGINE ECONOMICAL SPEED TEST ON SI ENGINE

AIM:

To Conduct Economical speed test on SI engine

INTRODUCTION:

The Test Rig is multi cylinder petrol engine coupled to a hydraulic brake and complete with all measurement systems, auto electrical panel , self-starter assembly, Morse test setup, battery etc., Engine is with 4 cylinder water cooled radiator is provided. Engine cooling is done by through continuous flowing water.

SPECIFICATIONS:

- Engine coupled to hydraulic brake
- Clutch arrangement
- Morse test setup
- Stand, Panel with all measurements
- Air tank, fuel tank
- Auto electrical with battery

DESCRIPTION OF THE APPARATUS:

Engine: Either PREMIERE / AMBASSODAR four cylinder four stroke water cooled automotive (reclaim) spark ignited with all accessories.

Make	: PREMIERE
Speed	: max 5000rpm
Power	: 23 HP at max speed
No of cylinders	: FOUR
Firing order	: 1-3-4-2
Cylinder bore	: 73mm
Stroke length	: 70mm
Spark plug gap	: 0.64mm

Other components include battery, starter motor, alternator/DC dynamo, ignition switch, solenoid, cables, accelerator assembly, radiator, valves etc.

HYDRAULIC BRAKE:

It is a reaction type hydraulic dynamometer; a stator body can swing in its axis, depending upon the torque on the shaft. The shaft is extended at both ends and supported between two bearings. Rotor is coupled at one end to the engine shaft. Water is allowed inside through stator and flows inside pockets of rotor and comes out of rotor. Any closure of valve or any restriction of flowing water, created breaking effect on the shaft, and which is reflected in opposition force of stator. Stator while reacting to proportional force pulls a spring balance, which is calibrated in kgs. Controlling all three valves enables to increase or decrease the load on the engine.

CLUTCH ARRANGEMENT:

A long lever with locking facility is provided. It helps to either couple engine to hydraulic brake or decouple both. Initially for no load do not couple these two and after increasing engine speed slowly engage same. Do not allow any water to dynamometer when engine is started. This is no load reading.

OBSERVATIONS:

- | | |
|-------------------------------------|-------------------------|
| 11. Orifice diameter d_0 | =25mm |
| 12. Density of water ρ_w | =1000kg/m ³ |
| 13. Density of air ρ_a | =1.2kg/m ³ |
| 14. Density of Petrol ρ_f | =0.7kg/lit |
| 15. Acceleration due to gravity g | =9.81m/sec ² |
| 16. Torque on length R | =0.3mt |
| 17. Calorific value of Petrol C_v | =43,210kJ/kg |
| 18. Cd of orifice | = 0.62 |
| 19. Cylinder bore D | =73mm |
| 20. Stroke length L | =70mm |

CONSTANT SPEED TEST:

1. After engine picks up speed slowly, engage clutch, now engine is coupled with hydraulic dynamometer.
2. With the help of accelerator, increase engine to say 1500rpm.
3. Note down the time required for 10litres of water flow, time required for 10cc of fuel, manometer reading, spring balance reading, all temperatures.
4. For next load allow more water into dynamometer and also adjust throttle valve such that engine is loaded but with same RPM, 1500rpm.
5. Note down all readings.
6. Repeat experiment for next higher load, max 8kw.

OPERATING DYNAMOMETER:

6. Inlet water Valveno1 (V1)-If knob is rotated clockwise LOAD is reduced, that means water entry is reduced.
7. If this V1 if rotated anti clock wise LOAD increased, here water is allowed into dynamometer-MORE the water into dynamometer MORE is LOAD.
8. Drain V2 if opened completely then load is reduced, if closed by rotating clockwise then LOAD is increased.
9. Overflow valve No.3 (V3)-if closed then Load is increased, If opened then LOAD is reduced.
10. In this manner load has to be increased or decreased.



TABULAR COLUMN:

Sl. No.	Speed, rpm	Spring balance Wkg	Manometer Reading			Time for 10 cc of fuel collected, t sec
			h ₁ cm	h ₂ cm	h _w = (h ₁ -h ₂)	

CALCULATIONS:

1. Area of Orifice $A_0 = \frac{\pi}{4} d_0^2 \text{ cm}^2$ (d_0 is orifice diameter = 25mm=0.025m)

2. Head of Air $H_a = \frac{(h_1 - h_2) \times \rho_w}{\rho_a}$ (in mts; $\rho_w = 1000 \text{ kg/cm}^3$
 $\rho_a = 1.2 \text{ kg/cm}^3$, h_1 and h_2 in mts)

3. Mass flow rate of Air M_a in kg/hr

$$M_a = A_0 \times C_d \times 3600 \times \rho_a \times \sqrt{2 \times g \times H_a} \text{ kg/hr}$$

4. Total fuel consumption TFC : in kg/hr

$$TFC = \frac{10 \times 3600 \times \rho_f}{t_1 \times 1000}$$

5. Brake Power BP in Kw
 - a. With hydraulic brake dynamometer (reaction type)
 - b. $BP = [2 \times \pi \times 9.81 \times N \times W \times R] / 60,000 \text{ kW}$

Where R= Load arm length = 0.3mts

W= load shown on spring balance,kg

N= speed in rpm

6. Specific fuel consumption: SFC in Kg/Kw-hr
 1. $SFC = TFC/BP$

7. Air Fuel ratio : A/F

$$A/F = Ma/TFC$$

8. Brake Thermal efficiency

$$\eta_{bth} = [BP/TFC \times CV] \times 100\%$$

Graphs:

Draw graph BP vs η_{bth} ,load,A/F.

PRE LAB QUESTIONS:

1. What are the 4strokes of SI engines?
2. What is the working cycle of SI Engine?
3. List out the performance parameters?
4. Indicate the different types of loads?
5. Differentiate SFC and TFC?
6. Concept of mass flow rate of air?

POST LAB QUESTIONS:

1. Dfferentiate brake power and indicated power?
2. Define brake thermal efficiency?
3. Indicate mechanical efficiency in terms of BP and IP?

EXPERIMENT 8

HEAT BALANCE TEST ON DIESEL ENGINE

AIM: The experiment is conducted to

- a) To study and understand the performance characteristics of the engine.
- b) To draw Performance curves and compare with standards.

INTRODUCTION

A machine, which uses heat energy obtained from combustion of fuel and converts it into mechanical energy, is known as a Heat Engine. They are classified as External and Internal Combustion Engine. In an External Combustion Engine, combustion takes place outside the cylinder and the heat generated from the combustion of the fuel is transferred to the working fluid which is then expanded to develop the power. An Internal Combustion Engine is one where combustion of the fuel takes place inside the cylinder and converts heat energy into mechanical energy. IC engines may be classified based on the working cycle, thermodynamic cycle, speed, fuel, cooling, method of ignition, mounting of engine cylinder and application.

Diesel Engine is an internal combustion engine, which uses heavy oil or diesel oil as a fuel and operates on two or four stroke. In a 4-stroke Diesel engine, the working cycle takes place in two revolutions of the crankshaft or 4 strokes of the piston. In this engine, pure air is sucked to the engine and the fuel is injected with the combustion taking place at the end of the compression stroke. The power developed and the performance of the engine depends on the condition of operation. So it is necessary to test an engine for different conditions based on the requirement.

DESCRIPTION OF THE APPARATUS:

Electrical Loading (Water cooled)

1. The equipment consists of **KIRLOSKAR** Diesel Engine (Crank started) of **5hp (3.7kW)** capacity and is Water cooled.
2. The Engine is coupled to a same capacity DC alternator with resistance heaters to dissipate the energy.
3. Thermocouples are provided at appropriate positions and are read by a digital temperature indicator with channel selector to select the position.
4. Rota meters of range 15LPM & 10LPM are used for direct measurement of water flow rate to the engine and calorimeter respectively.
5. Engine Speed and the load applied at various conditions is determined by a Digital RPM Indicator and spring balance reading.
6. A separate air box with orifice assembly is provided for regularizing and measuring the flow rate of air. The pressure difference at the orifice is measured by means of Manometer.
7. A volumetric flask with a fuel distributor is provided for measurement and directing the fuel to the engine respectively.

PROCEDURE:

1. Give the necessary electrical connections to the panel.
2. Check the lubricating oil level in the engine.
3. Check the fuel level in the tank.
4. Allow the water to flow to the engine and the calorimeter and adjust the flow rate to 6lpm & 3lpm respectively.
5. Release the load if any on the dynamometer.
6. Open the three-way cock so that fuel flows to the engine.
7. Start the engine by cranking.
8. Allow to attain the steady state.
9. Load the engine by slowly tightening the yoke rod handle of the Rope brake drum.
10. Note the following readings for particular condition,
 - a. Engine Speed
 - b. Time taken for ____cc of diesel consumption
 - c. Rota meter reading.
 - d. Manometer readings, in cm of water &
 - e. Temperatures at different locations.
11. Repeat the experiment for different loads and note down the above readings.
12. After the completion release the load and then switch of the engine.
13. Allow the water to flow for few minutes and then turn it off.



Diesel Engine

TABULAR COLUMN:

Sl. No.	Speed, rpm	Spring balance W kg	Manometer Reading			Time for 10 cc of fuel collected, t sec	Voltmeter reading	Ammeter reading
			h1 cm	h2 cm	h _w = (h1~h2)			

CALCULATIONS:

1. Mass of fuel consumed, m_f

$$M_f = (X_{cc} \times \text{Specific gravity of the fuel}) 1000 \times t \text{ kg/sec}$$

Where,

$$S_g \text{ of Diesel is } = 0.827$$

X_{cc} is the volume of fuel consumed = 10ml

t is time taken in seconds

2. Heat Input, H_i

$$H_i = m_f \times \text{Calorific Value of Fuel kW}$$

Where, Calorific value of diesel = 44631.96 kJ/kg

3. Output Or Brake Power, B_p

$$BP = (V \times I) / 1000 \text{ KW}$$

Where,

V = Voltmeter reading in volts

I = Ammeter reading in Amps

Tabular column for temperatures

SNO	T1	T2	T3	T4	T5	T6

Heat Balance Sheet Calculations:

C. Credit side:

Heat Input: H_i

$$H_i = \frac{TFC \times CV}{60} \text{ kJ/min}$$

D. Debit Side:

e. Heat converted into useful work H_b

$$H_b = BP \times 60 \text{ kJ/min}$$

f. Heat carried away by engine cooling water H_w

$$H_w = \frac{1 \times C_{pw} \times (T_3 - T_2)}{t_2} \times 60 \text{ kJ/min}$$

g. Heat carried away by exhaust gases

$$H_e = [M_e \times C_{pg} \times (T_4 - T_1)] \text{ kJ/min}$$

M_e = mass flow rate of exhaust gas in Kg/min

C_{pg} = specific heat of exhaust gas 1.005 kJ/KgK

$M_e = M_a + TFC$ in Kg/hr.

h. Un accountable losses:

$$H_u = [H_i] - \{H_b + H_w + H_e\} \text{ kJ/min}$$

HEAT BALANCE SHEET:

Credit Side (Input)				Debit Side (Out Put)			
Sl. No.	Particulars	Heat, Kj/Min	%	Sl. No.	Particulars	Heat, Kj/Min	%
	H_i				H_b		
					H_w		
					H_e		
					H_u		
Total:			100				100

PRE LAB QUESTIONS:

1. What are the 4 strokes of CI engines?
2. What is the working cycle of CI Engine?
3. List out the performance parameters?
4. Indicate the different types of loads?
5. Differentiate SFC and TFC?
6. Describe different heat losses in CI engines?

POST LAB QUESTIONS:

1. Differentiate brake power and indicated power?
2. Define brake thermal efficiency?
3. Explain the heat balancing of Diesel engine?

EXPERIMENT NO: 9

I C ENGINES AFFECT OF AIR FUEL RATIO IN A S I ENGINE

AIM: To determine the effect of A/F ratio on S I Engine.

INTRODUCTION

Test rig is with two stroke Bajaj make Petrol engine, coupled to Electrical dynamometer. Engine is air cooled type, hence only load test can be conducted at a constant speed of 3000rpm. Test rig is complete with base, air measurement, fuel measurement and temperature measurement system. Thermocouple is employed to measure temperature digitally.

Two stroke engines are coupled with ports closing at inlet and exhaust. Hence when compared to four stroke engine, it has low fuel efficiency because scavenging effect. But its construction and maintenance is easy, and costs less.

TEST SET UP:

01. Main chassis, engine coupled to dynamometer
02. Control desk with all measurements
03. Hoses, cables, thermocouples, misc.

CHASIS:

It is made from strong MS channels, with foundation facility. Supportbracket, to hold by hand while kick starting the engine.

Engine:

Bajaj classic/Chetek

Two stroke, single cylinder, air cooled, petrol driven

Compression Ratio : 7.4:1

Ignition timing : Spark advance of 22 degree before TDC

Bore : 57 mm

Stroke length : 57 mm

Displacement : 145.45 cc

Observations:

1. Orifice diameter d_0 = 15.25mm
2. Density of water ρ_w = 1000kg/m³
3. Density of air ρ_a = 1.2kg/m³
4. Density of Petrol ρ_f = 0.7kg/lit
5. Acceleration due to gravity g = 9.81m/sec²
6. Alternator efficiency η_g = 70%
7. Calorific value of Petrol C_v = 43,210kJ/kg
8. Cd of orifice C_d = 0.62
9. Cylinder bore D = 57mm
10. Stroke length L = 57mm

TABULAR COLUMN:

Sl. No.	Speed, rpm	Spring balance Wkg	Manometer Reading			Time for 10 cc of fuel collected, t sec
			h ₁ cm	h ₂ cm	h _w = (h ₁ ~h ₂)	

PROCEDURE:

1. Fill up water in manometer to required level
2. Ensure petrol level in the fuel tank.
3. Ensure engine oil.
4. Put MCB of alternator to ON, switch of all load bank or bring aluminium conductor of water loading rheostat above water level.
5. Add water
6. Switch ON ignition
7. Fix accelerator at some setting
8. Now kick start the engine and when it pickups speed adjust at 3000 rpm
9. at this no load note down manometer, speed ,temperature, voltage current and time for 10 cc of fuel consumption.
10. Repeat for different loads.

CALCULATIONS:

1. Area of Orifice $A_0 = \frac{\pi}{4} d_0^2 \text{sq.cm}$ (d_0 is orifice diameter = mm)

2. Manometer Head $H_a = (h_1 - h_2) \times \frac{\rho_w}{\rho_a}$ m ($\rho_w = 1000 \text{kg/m}^3$)

1. $\rho_a = 1.2 \text{kg/m}^3$

2. h_1 and h_2 in m

3. Mass flow rate of Air M_a in kg/hr

$$M_a = A_0 \times C_d \times 3600 \times \rho_a \times \sqrt{2 \times g \times H_a} \text{ kg/hr}$$

4. Total fuel consumption TFC : in kg/hr

$$\text{TFC} = \frac{10 \times 3600 \times \rho_f}{t_1 \times 1000}$$

5. Brake Power BP in Kw

$$BP = \frac{VI}{\eta_g \times 1000} \text{ kW}$$

6. Specific fuel consumption: SFC in Kg/Kw-hr

$$SFC = TFC/BP$$

7. Air Fuel ratio : A/F

$$A/F = Ma/TFC$$

GRAPHS:

Plot curves of BP vs. TFC, SFC, A/F,

PRECAUTIONS:

1. Do not allow speed above 3000 rpm
2. Don't increase load above 8 Amps
3. Don't run engine without engine oil
4. Mix petrol and 2T oil at 1 liter.

PRE LAB QUESTIONS:

1. What are the 4 strokes of SI engines?
2. What is the working cycle of SI Engine?
3. List out the performance parameters?
4. Indicate the different types of loads?
5. Differentiate SFC and TFC?
6. Define Air –Fuel ratio?

POST LAB QUESTIONS:

1. Differentiate brake power and indicated power?
2. Define brake thermal efficiency?
3. Indicate mechanical efficiency in terms of BP and IP?
4. How the Air-fuel ratio effects the brake thermal efficiency?

EXPERIMENT NO: 10

PERFORMANCE TEST ON VARIABLE COMPRESSION RATIO ENGINE

AIM: The experiment is conducted to

- a) To study and understand the performance characteristics of the engine.
- b) To draw Performance curves and compare with standards.

INTRODUCTION

A machine, which uses heat energy obtained from combustion of fuel and converts it into mechanical energy, is known as a Heat Engine. They are classified as External and Internal Combustion Engine. In an External Combustion Engine, combustion takes place outside the cylinder and the heat generated from the combustion of the fuel is transferred to the working fluid which is then expanded to develop the power. An Internal Combustion Engine is one where combustion of the fuel takes place inside the cylinder and converts heat energy into mechanical energy. IC engines may be classified based on the working cycle, thermodynamic cycle, speed, fuel, cooling, method of ignition, mounting of engine cylinder and application.

Diesel Engine is an internal combustion engine, which uses heavy oil or diesel oil as a fuel and operates on two or four stroke. In a 4-stroke Diesel engine, the working cycle takes place in two revolutions of the crankshaft or 4 strokes of the piston. In this engine, pure air is sucked to the engine and the fuel is injected with the combustion taking place at the end of the compression stroke. The power developed and the performance of the engine depends on the condition of operation. So it is necessary to test an engine for different conditions based on the requirement.

DESCRIPTION OF THE APPARATUS:

Electrical Loading (Water cooled)

1. The equipment consists of **KIRLOSKAR** Diesel Engine (Crank started) of **5hp (3.7kW)** capacity and is Water cooled.
2. The Engine is coupled to a same capacity DC alternator with resistance heaters to dissipate the energy.
3. Thermocouples are provided at appropriate positions and are read by a digital temperature indicator with channel selector to select the position.
4. Rota meters of range 15LPM & 10LPM are used for direct measurement of water flow rate to the engine and calorimeter respectively.
5. Engine Speed and the load applied at various conditions is determined by a Digital RPM Indicator and spring balance reading.
6. A separate air box with orifice assembly is provided for regularizing and measuring the flow rate of air. The pressure difference at the orifice is measured by means of Manometer.
7. A volumetric flask with a fuel distributor is provided for measurement and directing the fuel to the engine respectively.

PROCEDURE:

1. Give the necessary electrical connections to the panel.
2. Check the lubricating oil level in the engine.
3. Check the fuel level in the tank.
4. Allow the water to flow to the engine and the calorimeter and adjust the flow rate to 6lpm & 3lpm respectively.
5. Release the load if any on the dynamometer.
6. Open the three-way cock so that fuel flows to the engine.
7. Start the engine by cranking.
8. Allow to attain the steady state.
9. Load the engine by slowly tightening the yoke rod handle of the Rope brake drum.
10. Note the following readings for particular condition,
 - a. Engine Speed
 - b. Time taken for ____cc of diesel consumption
 - c. Rota meter reading.
 - d. Manometer readings, in cm of water &
 - e. Temperatures at different locations.
11. Repeat the experiment for different loads and note down the above readings.
12. After the completion release the load and then switch of the engine.
13. Allow the water to flow for few minutes and then turn it off.



Fig: Variable Compression Ratio Engine

TABULAR COLUMN:

Sl. No.	Speed, rpm	Spring balance W kg	Manometer Reading			Time for 10 cc of fuel collected, t sec	Voltmeter reading	Ammeter reading
			h ₁ cm	h ₂ cm	h _w = (h ₁ -h ₂)			

CALCULATIONS:

4. Mass of fuel consumed, m_f

$$M_f = (X_{cc} \times \text{Specific gravity of the fuel}) 1000 \times t \text{ kg/sec}$$

Where,

S_g of Diesel is = 0.827

X_{cc} is the volume of fuel consumed = 10ml

t is time taken in seconds

5. Heat Input, H_I

$$H_I = m_f \times \text{Calorific Value of Fuel kW}$$

Where, Calorific value of diesel = 44631.96 kJ/kg

6. Output Or Brake Power, B_p

$$BP = (V \times I) / 1000 \text{ KW}$$

Where,

V = Voltmeter reading in volts

I = Ammeter reading in Amps

7. Specific Fuel Consumption, S_{fc}

$$SFC = m_f \times 3600 / BP \text{ kg/KW-hr}$$

8. Brake Thermal Efficiency $\eta_{bth}\%$

$$\eta_{bth}\% = (3600 \times 100) / (SFC \times CV)$$

9. Mechanical Efficiency $\eta_{mech}\%$

$$\eta_{mech}\% = (BP / IP) \times 100$$

Determine the IP = Indicated power, using WILLAN'S LINE method and the procedure is as below:

- Draw the graph of Fuel consumption Vs. Brake power.
- Extend the line obtained till it cuts the brake power axis.
- The point where it cuts the brake power axis till the zero point will give the power losses (Friction Power loss)
- With this IP can be found using the relation:

$$IP = BP + FP$$

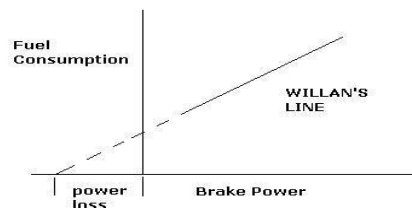

10. Calculation Of Head Of Air, H_a

$$H_a = h_w \times (\rho_w / \rho_a)$$

Where;

$$\rho_w = 1000 \text{ kg/m}^3$$

$$\rho_a = 1.2 \text{ kg/m}^3$$

h_w is the head in water column in 'm' of water

11. Volumetric Efficiency, $\eta_{vol}\%$

$$\eta_{vol}\% = (Q_a / Q_{th}) \times 100$$

where,

$$Q_a = \text{actual volume of air taken} = C_d \times a \times \sqrt{2gH_a}$$

Where C_d = Coefficient of discharge of orifice = 0.62

$$a = \text{area of the orifice} = [(\pi(0.02)^2)/4]$$

H_a = head in air column, m of air.

Q_{th} = theoretical volume of air taken

$$Q_{th} = \frac{L \times A \times N}{60 \times 2} \quad [A = (\pi \times D^2) / 4]$$

Where D = Bore diameter of the engine = 0.08m

L = Length of the stroke = 0.110m

N is speed of the engine in rpm

TABLATIONS:

Sl. No	Input Power	Output Power	SFC	Brake Thermal Efficiency	Mechanical Efficiency	Volumetric efficiency

CALCULATIONS:

2. FRICTION POWER, FP

$$FP = (V \cdot I) / 1000 \text{ KW}$$

Where,

V= voltmeter reading on motoring side

I = ammeter reading on motoring side

Graphs to be plotted: 1) SFC v/s BP 2) η_{bth} v/s BP 3) η_{mech} v/s BP 4) η_{vol} v/s BP

RESULT:

PRE LAB QUESTIONS:

1. What are the 4strokes of CI engines?
2. What is the working cycle of CI Engine?
3. List out the performance parameters?
4. Indicate the different types of loads?
5. Differentiate SFC and TFC?
6. Concept of mass flow rate of air?

POST LAB QUESTIONS:

1. Ddifferentiate brake power and indicated power?
2. Define brake thermal efficiency?
3. Indicate mechanical efficiency in terms of BP and IP?
4. Determine frictional power by using wilson's line?

EXPERIMENT NO: 11
VOLUMETRIC EFFICIENCY OF A RECIPROCATING AIR COMPRESSOR

AIM: The experiment is conducted at various pressures to

- a. Determine the Volumetric efficiency.
- b. Determine the Isothermal efficiency.

INTRODUCTION:

A COMPRESSOR is a device, which sucks in air at atmospheric pressure & increases its pressure by compressing it. If the air is compressed in a single cylinder it is called as a Single Stage Compressor. If the air is compressed in two or more cylinders it is called as a Multi Stage Compressor.

In a Two Stage Compressor the air is sucked from atmosphere & compressed in the first cylinder called the low-pressure cylinder. The compressed air then passes through an inter cooler where its temperature is reduced. The air is then passed into the second cylinder where it is further compressed. The air further goes to the air reservoir where it is stored.

DESCRIPTION OF THE APPARATUS:

1. Consists of Two Stage Reciprocating air compressor of 3hp capacity. The compressor is fitted with similar capacity Motor as a driver and 160lt capacity reservoir tank.
2. Air tank with orifice plate assembly is provided to measure the volume of air taken and is done using the Manometer provided.
3. Compressed air is stored in an air reservoir, which is provided with a pressure gauge and automatic cut-off.
4. Necessary Pressure and Temperature tapings are made on the compressor for making different measurements
5. Temperature is read using the Digital temperature indicator and speed by Digital RPM indicator.

PROCEDURE:

1. Check the necessary electrical connections and also for the direction of the motor.
2. Check the lubricating oil level in the compressor.
3. Start the compressor by switching on the motor.
4. The slow increase of the pressure inside the air reservoir is observed.
5. Maintain the required pressure by slowly operating the discharge valve (open/close). (Note there may be slight variations in the pressure readings since it is a dynamic process and the reservoir will be filled continuously till the cut-off.)
6. Now note down the following readings in the respective units,
Speed of the compressor. Manometer readings.
Delivery pressure. Temperatures.
Energy meter reading.
7. Repeat the experiment for different delivery pressures.

8. Once the set of readings are taken switch of the compressor.
9. The air stored in the tank is discharged. Be careful while doing so, because the compressed air passing through the small area also acts as a air jet which may damage you or your surroundings.
10. Repeat the above two steps after every experiment.



Volumetric Efficiency of a Reciprocating Air Compressor

OBSERVATIONS:

Sl. No.	Compressor Speed, rpm	Delivery Pressure, 'P' kg/cm ²	Manometer Reading			Time for 'n' revolutions of energy meter, 'T' sec
			h ₁ cm	h ₂ cm	h _w = (h ₁ ~h ₂)	

CALCULATIONS:

1. Air head causing flow, h_a

$$\text{Manometer Head } H_a = (h_1 - h_2) \times \frac{\rho_w}{\rho_a} \text{ m}$$

$$\rho_w = 1000 \text{ kg/m}^3$$

$$\rho_a = 1.293 \text{ kg/m}^3, h_1 \text{ and } h_2 \text{ in m}$$

2. Actual vol. of air compressed at RTP,

Where,

h_a is air head causing the flow in **m** of air.

C_d = coefficient of discharge of orifice = 0.62

$$a = \text{Area of orifice} = \frac{\pi}{4} d^2$$

Where,

d = diameter of orifice = 0.02m

3. Theoretical volume of air compressed Q_{th} ,

Where,

D is the diameter of the LP cylinder = 0.07m.

L is Stroke Length = 0.085m

N is speed of the compressor in rpm

4. Input Power, **IP**

$$3600 * n * \eta_m / (K * T) \dots \dots \dots \text{kW}$$

Where,

n = No. of revolutions of energy meter (Say 5)

K = Energy meter constant revs/kW-hr

T = time for 5 rev. of energy meter in seconds

η_m = efficiency of belt transmission = 75%

5. Isothermal Work done, **WD**

$$\text{WD} = \rho_a \times Q_a \ln r \times W$$

Where,

ρ_a = is the density of the air = 1.293 kg/m³ Q_a

= Actual volume of air compressed.

r = Compression ratio

$r = \frac{\text{Delivery gauge pressure} + \text{Atmospheric pressure}}{\text{Atmospheric pressure}}$

Where Atmospheric pressure = 101.325 kPa

NOTE: To convert delivery pressure from kg/cm² to kPa multiply by 98.1

6. Volumetric efficiency, η_{vol}

$$\eta_{vol} = Q_a / Q_{th} \times 100$$

7. Isothermal efficiency, η_{iso}

$$\eta_{iso} = \frac{\text{Isothermal work done}}{IP} \times 100$$

TABULATIONS:

S. No	Head of Air h_a , m	Actual volume of air compressed Q_a , m^3/s	Theoretical vol of air compressed Q_{th} , m^3/s	Isothermal work done Kw	Iso thermal efficiency η_{iso} , %	Volumetric Efficiency η_{vol} , %

GRAPHS TO BE PLOTTED:

1. Delivery Pressure vs. η_{vol}
2. Delivery Pressure vs. η_{iso}

PRECAUTIONS:

1. Do not run the blower if supply voltage is less than 380V
2. Check the direction of the motor, if the motor runs in opposite direction change the phase line of the motor to run in appropriate direction.
3. Do not forget to give electrical earth and neutral connections correctly.

RESULT:

PRE LAB QUESTIONS:

1. What is the principle of compressor?
2. Differentiate various types of compressors?
3. Explain concept of multi staging?

POST LAB QUESTIONS?

1. Differentiate single stage and multistage compressor?
2. Define isothermal work done?
3. What is isothermal efficiency?

EXPERIMENT NO:12

DIS-ASSEMBLY/ASSEMBLY OF I.C. ENGINE

AIM:

Dismantling and reassembling of a 4 stroke petrol engine.

Apparatus:

Spanner set, Work bench, screw driver, spark plug spanner, spark plug cleaner, tray, kerosene oil, cotton waste, hammer, oil can etc.

Theory:

In 1878, a British engineer introduced a cycle which could be completed in two strokes of piston rather than four strokes as is the case with the four-stroke cycle engines.

In this engine suction and exhaust strokes are eliminated. Here instead of valves, ports are used. The exhaust gases are driven out from engine cylinder by the fresh charge of fuel entering the cylinder nearly at the end of the working stroke.

A two-stroke petrol engine is generally used in scooters, motor cycles etc.

The cylinder L is connected to a closed crank chamber C.C. During the upward stroke of the piston M, the gases in L are compressed and at the same time fresh air and fuel (petrol) mixture enters the crank chamber through the valve.

Different Parts of I.C. Engine

Cylinder, Cylinder head, Piston, Piston rings, Gudgeon pin, Connecting rod, Crankshaft, Crank, Engine bearing, Crank case, Flywheel etc.

Parts of a 2 Stroke Petrol Engine

Cylinder Head

Also referred to as the top end, the cylinder head houses the pistons, valves, rocker arms and camshafts.

Valves

A pair of valves, used for controlling fuel intake and exhaust, is controlled by a set of fingers on the camshaft called lobes. As the intake valve opens, a mixture of fuel and air from the carburetor is pulled into the cylinder. The exhaust valve expels the spent air/fuel mixture after combustion.

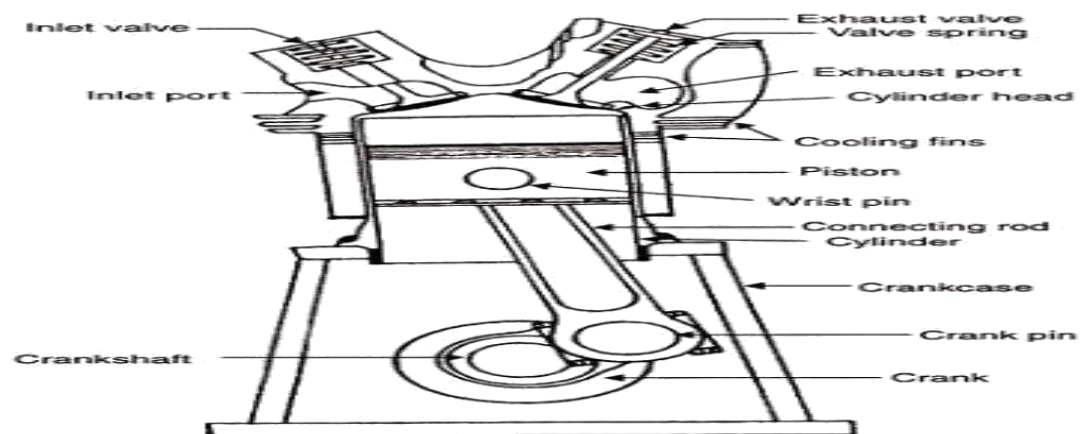



Dis-Assembly/Assembly of I.C. Engine

Camshaft

Usually chain or gear-driven, the camshaft spins, using its lobes to actuate the rocker arms. These open the intake and exhaust valves at preset intervals.

The Piston

The piston travels up and down within the cylinder and compresses the air/fuel mixture to be ignited by a spark plug. The combusive force propels the piston downward. The piston is attached to a connecting rod by a wrist pin.

Piston rings:

These are circular rings which seal the gaps made between the piston and the cylinder, their object being to prevent gas escaping and to control the amount of lubricant which is allowed to reach the top of the cylinder.

Gudgeon-pin:

This pin transfers the thrust from the piston to the connecting-rod small-end while permitting the rod to rock to and fro as the crankshaft rotates.

Connecting-rod:

This acts as both a strut and a tie link-rod. It transmits the linear pressure impulses acting on the piston to the crankshaft big-end journal, where they are converted into turning-effort.

Crankshaft

The crankshaft is made up of a left and right flywheel connected to the piston's

connecting rod by a crank pin, which rotates to create the piston's up-and-down motion. The cam chain sprocket is mounted on the crankshaft, which controls the chain that drives the camshaft.

The CARBURETTOR

The carburetor is the control for the engine. It feeds the engine with a mixture of air and petrol in a controlled volume that determines the speed, acceleration and deceleration of the engine. The carburetor is controlled by a slide connected to the throttle cable from the handlebar twist grip which adjusts the volume of air drawn into the engine.

Procedure:

- 1) Dismantle the following system
 - a) Fuel supply system
 - b) Electrical system
- 2) Remove the spark plug from the cylinder head.
- 3) Remove the cylinder head nut and bolts.
- 4) Separate the cylinder head from the engine block.
- 5) Remove the carburetor from the engine.
- 6) Open the crank case.
- 7) Remove piston rings from the piston.
- 8) Clean the combustion chamber.
- 9) Reassemble the components vice versa.

Precautions:

1. Don't use loose handle of hammer.
2. Care must be taken while removing the components.

Result:

A 2 – stroke petrol engine has been dismantled and reassembled.

PRE LAB QUESTIONS:

1. List the various components of IC Engine?
2. Describe different materials used for different components?
3. What is the function of carburetor?

POST LAB QUESTIONS:

1. Identifying the different components in IC Engine?
2. Explain working of different parts?

EXPERIMENT NO: 13

STUDY OF BOILERS

A) STUDY OF BABCOCK-WILCOX BOILER

Aim: To study Babcock-Wilcox boiler.

Theory: Evaporating the water at appropriate temperatures and pressures in boilers does the generation of steam. A boiler is defined as a set of units, combined together consisting of an apparatus for producing and recovering heat by igniting certain fuel, together with arrangement for transferring heat so as to make it available to water, which could be heated and vaporized to steam form. One of the important types of boilers is Babcock-Wilcox boiler.

Observation: In thermal powerhouses, Babcock Wilcox boilers degeneration of steam in large quantities.

The boiler consists essentially of three parts.

1. **A number of inclined water tubes:** They extend all over the furnace. Water circulates through them and is heated.
2. **A horizontal steam and water drum:** Here steam separate from the water which is kept circulating through the tubes and drum.
3. **Combustion chambers:** The whole of space where water tubes are laid is divided into three separate chambers, connected to each other so that hot gases pass from one to the other and give out heat in each chamber gradually. Thus the first chamber is the hottest and the last one is at the lowest temperature. All of these constituents have been shown as in fig.

The Water tubes 76.2 to 109 mm in diameter are connected with each other and with the drum by vertical passages at each end called

Headers. Tubes are inclined in such a way that they slope down towards the back. The rear header is called the down-take header and the front header is called the uptake header has been represented in the fig as DC and VH respectively.

Whole of the assembly of tubes is hung along with the drum in a room made of masonry work, lined with fire bricks. This room is divided into three compartments A, B, and C as shown in fig, so that first of all, the hot gases rise in A and go down in B, again rises up in C, and then the led to the chimney through the smoke chamber C. A mud collector M is attached to the rear and lowest point of the boiler into which the sediment i.e. suspended impurities of water are collected due to gravity, during its passage through the down take header.

Below the front uptake header is situated the grate of the furnace, either automatically or manually fired depending upon the size of the boiler. The direction of hot gases is maintained upwards by the baffles L.

In the steam and water drum the steam is separated from the water and the remaining water travels to the back end of the drum and descends through the down take header

where it is subjected to the action of fire of which the temperature goes on increasing towards the uptake header. Then it enters the drum where the separation occurs and similar process continues further.

For the purpose of super heating the steam addition sets of tubes of U-shape fixed horizontally, are fitted in the chamber between the water tubes and the drum. The steam passes from the steam face of the drum downwards into the super heater entering at its upper part, and spreads towards the bottom. Finally the steam enters the water box W, at the bottom in a super-heated condition from where it is taken out through the outlet pipes.

The boiler is fitted with the usual mountings like main stop valve M, safety valve S, and feed valve F, and pressure gauge P.

Main stop valve is used to regulate flow of steam from the boiler, to steam pipe or from one steam pipe to another.

The function of safety valve is used to safeguard the boiler from the hazard of pressures higher than the design value. They automatically discharge steam from the boiler if inside pressure exceeds design-specified limit. Feed check valve is used to control the supply of water to the boiler and to prevent the escaping of water from boiler due to high pressure inside. Pressure gauge is an instrument, which records the inside pressure of the boiler. When steam is raised from a cold boiler, an arrangement is provided for flooding the super heater. By this arrangement the super heater is filled with the water up to the level. Any steam is formed while the super heater is flooded is delivered to the drum ultimately when it is raised to the working pressure. Now the water is drained off from the super heater through the cock provided for this purpose, and then steam is let in for super heating purposes.

Result: The Babcock – Wilcox boiler is studied.

B)STUDY OF LANCASHIRE BOILER

AIM: To study Lancashire boiler.

Theory: Evaporating the water at appropriate temperatures and pressures in boilers does the generation of steam. A boiler is defined as a set of units, combined together consisting of an apparatus for producing and recovering heat by igniting certain fuel, together with arrangement for transferring heat so as to make it available to water, which could be heated and vaporized to steam form. One of the important types of boilers is Lancashire boiler.

Observation: Lancashire boiler has two large diameter tubes called **flues**, through which the hot gases pass. The water filled in the main shell is heated from within around the flues and also from bottom and sides of the shell, with the help of other masonry ducts constructed in the boiler as described below.

The main boiler shell is of about 1.85 to 2.75 m in diameter and about 8 m long. Two large tubes of 75 to 105 cm diameter pass from end to end through this shell. These are called **flues**. Each flue is provided with a **fire door** and a **grate** on the front end. The boiler is placed in a masonry structure which forms the external flues through which, also, hot gases pass and thus the boiler shell also forms a part of the heating surface. The whole arrangement of the brickwork and placing of boiler shell and flues is as shown in fig.

SS is the boiler **shell** enclosing the main **flue tubes**. SF is the **side flues** running along the length of the shell and BF is the **bottom flue**. Side and bottom flues are the ducts, which are provided in masonry itself.

The draught in this boiler is produced by chimney. The hot gases starting from the grate travel all along the flue tubes; and thus transmit heat through the surface of the flues. On reaching at the back end of the boiler they go down through a passage, they heat water through the lower portion of the main water shell. On reaching again at front end they bifurcate to the side flues and travel in the forward direction till finally they reach in the smoke chamber from where they pass onto chimney.

During passage through the side flues also they provide heat to the water through a part of the main shell. Thus it will be seen that sufficient amount of area is provided as heating surface by the flue tubes and by a large portion of the shell

Operating the dampers L placed at the exit of the flues may regulate the flow of the gases. Suitable firebricks line the flues. The boiler is equipped with suitable

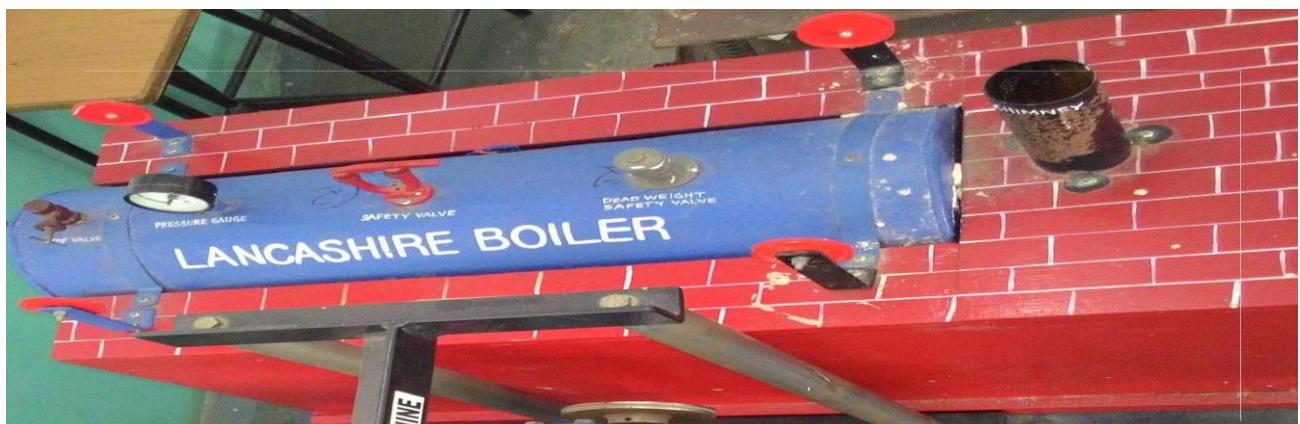

Study of Lancashire Boiler

Firebricks line the flues. The boiler is equipped with suitable mountings and accessories.

There is a special advantage possessed by such types of boilers. The products of combustion are carried through the bottom flues only after they have passed through the main flue tubes, hence the hottest portion does not lie in the bottom of the boiler, where the sediment contained in water as impurities is likely to fall. Therefore there are less chances of unduly heating the plates at the bottom due to these sediments.

Result: The Lancashire boiler is studied.

PRE LAB QUESTIONS:

1. What is the function of boiler?
2. What are the different types of boilers?
3. Explain the terms used for boilers?
4. Differentiate water tube and fire tube boilers?

POST LAB QUESTIONS:

1. Explain the working principles of various boilers?
2. Advantages of high pressure boilers?