

# **LAB MANUAL**

## **WORK SHOP/MANUFACTURING PROCESS LABORATORY**

**CourseCode** : **AMEB01**  
**Regulations** : **IARE –R18**  
**Semester** : **I / II**  
**Branch** : **CE|ECE | EEE**

**Prepared by**

**Mrs. V.Prasanna**  
**AssistantProfessor**



**INSTITUTE OF AERONAUTICAL ENGINEERING**

**(Autonomous)**

**Dundigal, Hyderabad - 500 043**



# INSTITUTE OF AERONAUTICAL ENGINEERING

(Autonomous)

Dundigal, Hyderabad – 500043

| <b>Program Outcomes</b>          |   |
|----------------------------------|---|
| PO1                              | <b>Engineering knowledge:</b> Capability to apply the knowledge of Mathematics, science and Engineering in the field of Mechanical Engineering.   |
| PO2                              | <b>Problem analysis:</b> An Ability to analyze complex engineering problems to arrive at relevant conclusions using knowledge of Mathematics, Science and Engineering.  |
| PO3                              | <b>Design/development of solutions:</b> Competence to design a system, component or process to meet societal needs within realistic constraints.  |
| PO4                              | <b>Conduct investigations of complex problems:</b> To design and conduct research oriented experiments as well as to analyze and implement data using research methodologies.   |
| PO5                              | <b>Modern tool usage:</b> An ability to formulate solve complex engineering problem using modern engineering and Information technology tools.  |
| PO6                              | <b>The engineer and society:</b> To utilize the engineering practices, techniques, skills to meet needs of the health, safety, legal, cultural and societal issues.   |
| PO7                              | <b>Environment and sustainability:</b> To understand impact of engineering solutions in the societal context and demonstrate the knowledge for sustainable development.   |
| PO8                              | <b>Ethics:</b> An understanding and implementation of professional and Ethical responsibilities.  |
| PO9                              | <b>Individual and teamwork:</b> To function as an effective individual and as a member or leader in Multi-disciplinary environment and adopt in diverse teams.  |
| PO10                             | <b>Communication:</b> An ability to assimilate, comprehends, communicate, give and receive instructions to present effectively with engineering community and society.  |
| PO11                             | <b>Project management and finance:</b> An ability to provide leadership in managing complex engineering projects at multi-disciplinary environment and to become a professional engineer.   |
| PO12                             | <b>Life-long learning:</b> Recognition of the need and an ability to engage in lifelong learning to keep abreast with technological changes.  |
| <b>Program Specific Outcomes</b> |   |
| PSO1                             | <b>Professional skills:</b> Able to utilize the knowledge of aeronautical/aerospace engineering in innovative, dynamic and challenging environment for design and development of new products.  |
| PSO2                             | <b>Professional skills:</b> Imparted through simulation language skills and general purpose CAE packages to solve practical, design and analysis problems of components to complete the challenge of airworthiness for flight vehicles. |
| PSO3                             | <b>Practical implementation and testing skills:</b> Providing different types of in house and training and industry practice to fabricate and test and develop the products with more innovative technologies.                          |
| PSO4                             | <b>Successful career and entrepreneurship:</b> To prepare the students with broad aerospace knowledge to design and develop systems and subsystems of aerospace and allied systems and become technocrats.                              |



# INSTITUTE OF AERONAUTICAL ENGINEERING

(Autonomous)

Dundigal, Hyderabad – 500043

| <b>ATTAINMENT OF PROGRAM OUTCOMES &amp;<br/>PROGRAM SPECIFIC OUTCOMES</b> |   |                          |                                    |
|---|---|--------------------------|------------------------------------|
| S No  | Experiment  | Program Outcome Attained | Program Specific Outcomes Attained |
| 1   | MACHINE SHOP-TURNING AND OTHER MACHINES             | PO1, PO2, PO3            | PSO1, PSO3                         |
| 2   | MACHINE SHOP-MILLING AND OTHER MACHINES             | PO1, PO2, PO3            | PSO1, PSO3                         |
| 3   | ADVANCED MACHINE SHOP                               | PO1, PO2, PO3            | PSO1, PSO3                         |
| 4   | FITTING   | PO2, PO3                 | PSO1, PSO3                         |
| 5   | CARPENTRY-I   | PO3, PO4                 | PSO1, PSO3                         |
| 6   | CARPENTRY-II  | PO2, PO3                 | PSO1, PSO3                         |
| 7   | ELECTRICAL AND ELECTRONICS                          | PO2, PO3                 | PSO1, PSO3                         |
| 8   | WELDING   | PO2, PO3                 | PSO1, PSO3                         |
| 9   | MOULD PREPARATION                                   | PO3, PO4                 | PSO1, PSO3                         |
| 10  | MOULD PREPARATION                                   | PO3, PO4                 | PSO1, PSO3                         |
| 11  | BLACKSMITHY- I, TINSMITHY- I                        | PO2, PO3                 | PSO1, PSO3                         |
| 12  | TINSMITHY- I, BLACKSMITHY- I                        | PO2, PO3                 | PSO1, PSO3                         |
| 13  | PLASTIC MOULDING, INJECTION MOULDING, GLASS CUTTING | PO2, PO3                 | PSO1, PSO3                         |
| 14  | BLOW MOULDING                                       | PO2, PO3                 | PSO1, PSO3                         |



# INSTITUTE OF AERONAUTICAL ENGINEERING

(Autonomous)

Dundigal, Hyderabad - 500 043

## *Certificate*

*This is to Certify that it is a bonafied record of Practical work done by  
Sri/Kum. \_\_\_\_\_ bearing the  
Roll No. \_\_\_\_\_ of \_\_\_\_\_ Class  
\_\_\_\_\_ Branch in the  
\_\_\_\_\_ laboratory during the Academic  
year \_\_\_\_\_ under our supervision.*

**Head of the Department**

**Lecture In-Charge**

**External Examiner**

**Internal Examiner**

## WORKSHOP/MANUFACTURING PROCESS LABORATORY

| <b>I Semester: ME   CSE   IT   AE</b> |            | <b>II Semester: EEE / AE / ME / CE/ ECE</b> |   |                              |         |               |                          |       |
|---------------------------------------|------------|---|---|------------------------------|---------|---------------|--------------------------|-------|
| Course Code                           | Category   | Hours / Week                                |   |                              | Credits | Maximum Marks |                          |       |
| AMEB01                                | Foundation | L   | T | P                            | C       | CIA           | SEE                      | Total |
|                                       |            | -   | - | 3                            | 1.5     | 30            | 70                       | 100   |
| <b>Contact Classes: Nil</b>           |            | <b>Tutorial Classes: Nil</b>                |   | <b>Practical Classes: 45</b> |         |               | <b>Total Classes: 45</b> |       |

### COURSE OBJECTIVES:

**The course should enable the students to:**

- I. Identify and use of tools, types of joints in carpentry, fitting, tin smithy and plumbing operations.
- II. Understand of electrical wiring and components.
- III. Observation of the function of lathe, shaper, drilling, boring, milling, grinding machines.

### COURSE OUTCOMES (COs):

- CO 1: Explain different basic operations performed on lathe, drilling, grinding, milling, shaper machines.
- CO 2: Understand the different parts of the CNC turning, drilling, milling machines etc.
- CO 3: Identify the different joints used in carpentry, tin smithy, black smithy and fitting.
- CO 4: Apply the basic drawing for circuit diagrams used in house wiring.
- CO 5: Identify the different types of welding, moulding, glass cutting methods.

### COURSE LEARNING OUTCOMES (CLOs):

**The students should enable to:**

1. To identify different Tools required for Woodworking.
2. Familiarize the students to different cutting fluids.
3. Use of Cutting tools required for Metal working in the Fitting work.
4. Prepare Students for development of surfaces using the theory of Engineering Drawing and application of the same to the Tin Smithy.
5. Need for heating of the Mild Steel and to understand the Hot Working of the metals in Black Smithy.
6. To prepare circuit diagrams for house working for Series and Parallel Connection.
7. Understand the circuit connections for One Bulb connected with two way switches i.e., Stair Case connections.
8. To prepare Mould preparation and demonstration Casting Process.
9. Exposure for different types of solid state welding and other welding practices viz Arc welding, Gas welding, Brazing, Soldering etc.
10. Introduce Students with new technology manufacturing practices like 3D Printing.
11. Familiarize the students with the introduction of conventional machine tools like Lathe, Milling, Drilling etc.
12. Demonstrate Manufacturing practices on CNC Machine tools.

| <b>LIST OF EXPERIMENTS</b>   |  |
|--|--|
| <b>WEEK - 1</b>  | <b>MACHINE SHOP-TURNING AND OTHER MACHINES</b> |
| Batch I: Working on central lathe and shaping machine.<br>Batch II: Working on drilling, grinding machines.  |  |
| <b>WEEK - 2</b>  | <b>MACHINE SHOP-MILLING AND OTHER MACHINES</b> |
| Batch I: Working on milling machine.<br>Batch II: Working on milling and shaping machine.  |  |
| <b>WEEK - 3</b>  | <b>ADVANCED MACHINE SHOP</b>                   |
| Batch I: Working on CNC Turning machines.<br>Batch II: Working on CNC Vertical Drill Tap Center.   |  |
| <b>WEEK - 4</b>  | <b>FITTING</b>                                 |
| Batch I: Make a straight fit and straight fit for given dimensions.<br>Batch II: Make a square fit for straight fit for given sizes.   |  |
| <b>WEEK - 5</b>  | <b>CARPENTRY-I</b>                             |
| Batch I: Preparation of lap joint as per given dimensions.<br>Batch II: Preparation of dove tail joint as per given taper angle  |  |
| <b>WEEK - 6</b>  | <b>CARPENTRY-II</b>                            |
| Batch I: Preparation of dove tail joint as per given taper angle.<br>Batch II: Preparation of lap joint as per given dimensions.   |  |
| <b>WEEK - 7</b>  | <b>ELECTRICAL AND ELECTRONICS</b>              |
| Batch I : Make an electrical connection to demonstrate domestic voltage and current sharing.<br>Batch II: Make an electrical connection to control one bulb with two switches-stair case connection. |  |
| <b>WEEK - 8</b>  | <b>WELDING</b>                                 |
| Batch I: Arc welding & Gas Welding.<br>Batch II: Gas welding & Arc Welding.  |  |
| <b>WEEK - 9</b>  | <b>MOULD PREPARATION</b>                       |
| Batch I: Prepare a wheel flange mould using a given wooden pattern.<br>Batch II: Prepare a bearing housing using an aluminum pattern.  |  |
| <b>WEEK - 10</b>   | <b>MOULD PREPARATION</b>                       |
| Batch I: Prepare a bearing housing using an aluminum pattern.<br>Batch II: Prepare a wheel flange mould using a given wooden pattern.  |  |
| <b>WEEK - 11</b>   | <b>BLACKSMITHY- I, TINSMITHY- I</b>            |
| Batch I: Prepare S-bend & J-bend for given MS rod using open hearth furnace.<br>Batch II: Prepare the development of a surface and make a rectangular tray and a round tin.                          |  |

|   |  |
|---|--|
| <b>WEEK - 12</b>  | <b>TINSMITHY- I, BLACKSMITHY- I</b>                        |
| Batch I: Prepare the development of a surface and make a rectangular tray and a round tin.<br>Batch II: Prepare S-bend & J-bend of given MS rod using open hearth furnace.  |  |
| <b>WEEK - 13</b>  | <b>PLASTIC MOULDING, INJECTION MOULDING, GLASS CUTTING</b> |
| Batch I: Plastic Moulding and Glass cutting.<br>Batch II: Plastic Moulding and Glass cutting.   |  |
| <b>WEEK - 14</b>  | <b>BLOW MOULDING</b>                                       |
| Batch I& II: Blow Moulding.   |  |
| <b>Text Books:</b>  |  |
| <ol style="list-style-type: none"> <li>1 Hajra Choudhury S.K., Hajra Choudhury A.K. and Nirjhar Roy S.K., “Elements of Workshop Technology”, Vol. I 2008 and Vol. II 2010, Media promoters and publishers private limited, Mumbai.</li> <li>2 Kalpakjian S, Steven S. Schmid, “Manufacturing Engineering and Technology”, Pearson Education India Edition, 4<sup>th</sup> Edition, 2002.</li> </ol> |  |
| <b>Reference Books:</b>   |  |
| <ol style="list-style-type: none"> <li>1 Gowri P. Hariharan, A. Suresh Babu,” Manufacturing Technology – I”, Pearson Education,2008.</li> <li>2 Roy A. Lindberg, “Processes and Materials of Manufacture”, Prentice Hall India, 4<sup>th</sup> Edition, 1998.</li> <li>3 Rao P.N., “Manufacturing Technology”, Vol. I and Vol. II, Tata McGraw-Hill House,2017.</li> </ol>                          |  |
| <b>Web References:</b>  |  |
| <ol style="list-style-type: none"> <li>1 <a href="https://www.iare.ac.in">https://www.iare.ac.in</a></li> </ol>   |  |

## CARPENTRY INTRODUCTION

Carpentry deals with the processing of wood to obtain desired shapes and sizes. The process dealing with the technique of making wooden pattern is called pattern making. Wood obtained from tree is the chief product of forest. It has been universally acceptable as raw material for manufacturing wooden products or appliances. From the pre-historic times, wood has been utilized an important source of getting heat by firing it. It has been utilized as an major construction material for making shelter for the basic need of human being. The useful work on wood is being generally carried out in a most common shop known as carpentry shop. The work performed in carpentry shops comprises of cutting, shaping and fastening wood and other materials together to produce the products of woods. Therefore, carpentry shop deals with the timber, various types of tools and the art of joinery

The tools used in carpentry are listed below:

### 1. Steel Foot Rule:

It's one side has the graduations of  $1/8''$  and other is divided into markings of  $1/16''$ . Metric scales are also used, having the graduation in mm and cm.

**STEEL RULE:** Used for making and measuring linear dimensions. It is specified by its length.



Steel rule

**STEEL TAPE:** The steel tape is used for measuring longer dimensions. They are available in different sizes, ranging from 0.6 to 2.5 m. It is flexible can be coiled and presses in a case.





**2. Try Square:** It is an important tool for Squaring, testing and measuring. It is usually made of steel, but sometimes also with wood.

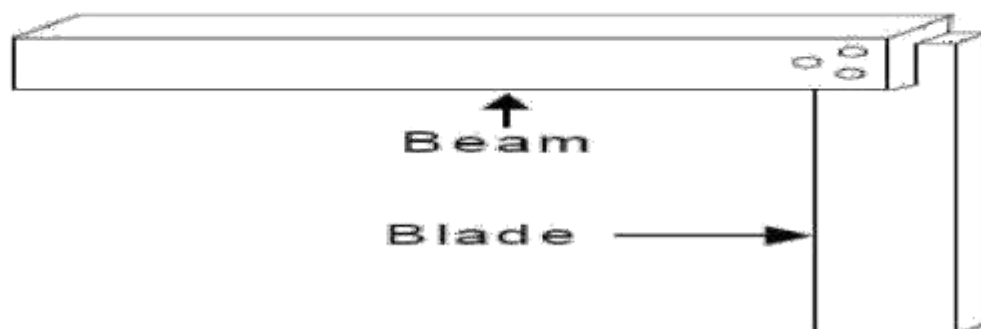

**3. Marking Gauge:** It is used for scoring or for following a line parallel to a given space, edge or end. It is made of wood. There is a sharp metal spur point. Main bar of the gauge has graduations printed on it similar to that of foot rule. It is always advisable to check the measurement from the spur point to movable head.

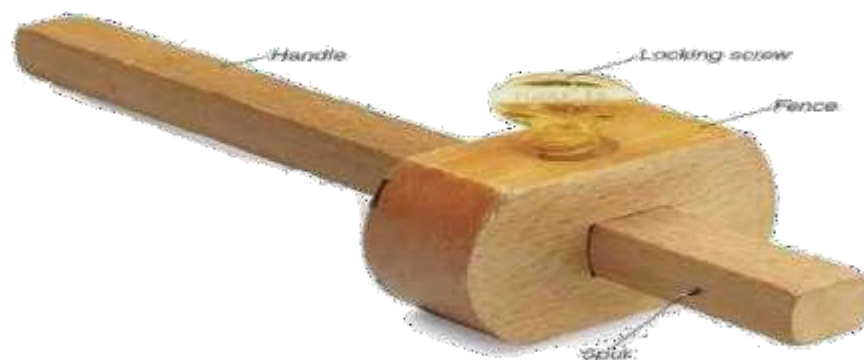

**4. Bevel Square:** This tool resembles the try square in appearance but has a movable blade which can be adjusted for laying out at any angle. It is also employed for testing chamfers, bevels and angles.



4 | Page

**5. Divider:** It consists of two pointed legs, the points are hardened and tempered to prevent wear. It is used for transferring the sizes and scribing curves or circles on wooden surface.

## EXERCISE NO – 1

### LAP HALVING JOINT

**Aim:** To prepare a lap Halving joint.

**Materials Required:** Teak wood piece of size 300x50x25mm.

**Tools Required:** Jack Plane, Try square, Tennon saw, Marking knife, 2ft rule, firmer chisel, Mallet.

**Procedure:**

**Precautions:**

1. Feed the saw from head to tool.
2. Care should be taken while operating with tools.

The saw teeth should not touch the hard material.

**Result :**

# HALF-LAP JOINT

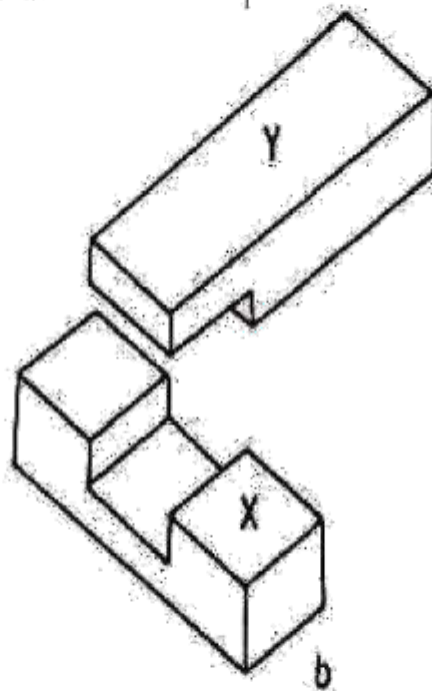
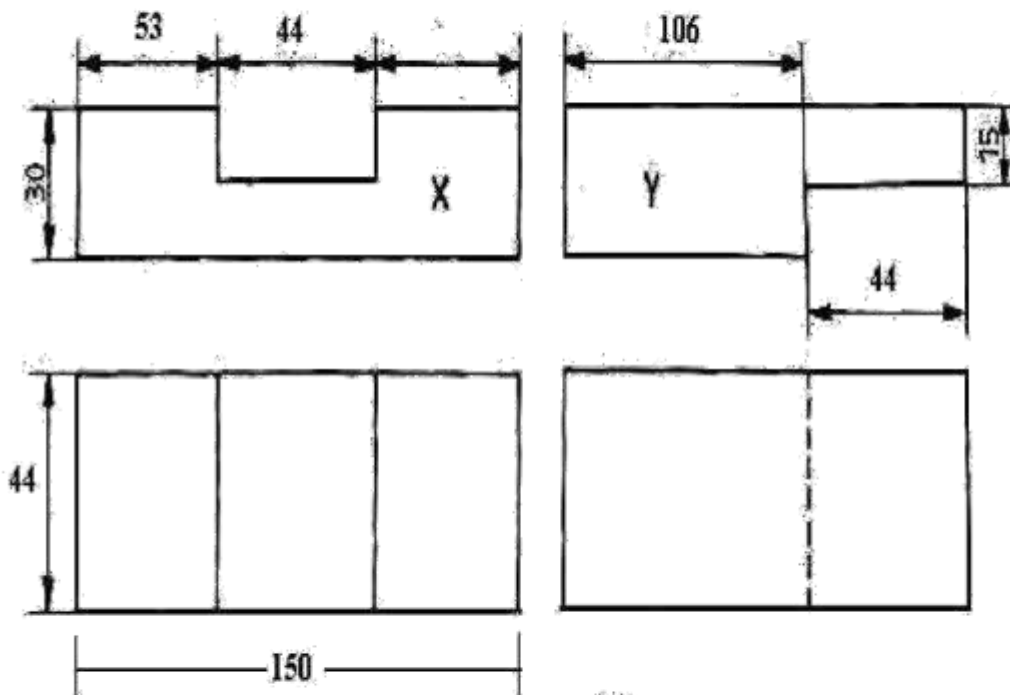

All Dimensions are in "mm"

## EXERCISE NO -2

### DOVETAIL HALVING JOINT

**Aim:** To prepare a Dovetail halving joint.

**Materials Required:** Teak wood piece of size 300x50x25mm.

**Tools Required:** Jack plane, Try square, Tennon saw, 2ft rule, Marking Knife, Firmer Chisel, Mallet.

**Procedure:**

**Precautions:**

1. The saw teeth should not touch the hard material.
2. Feed the saw from head to tool.

Result

## DOVETAIL JOINT

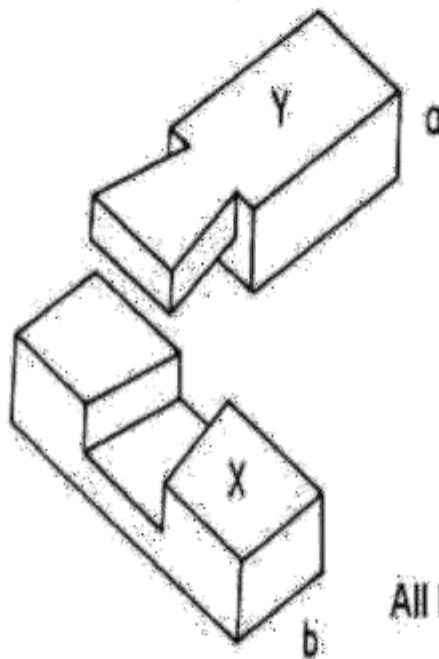
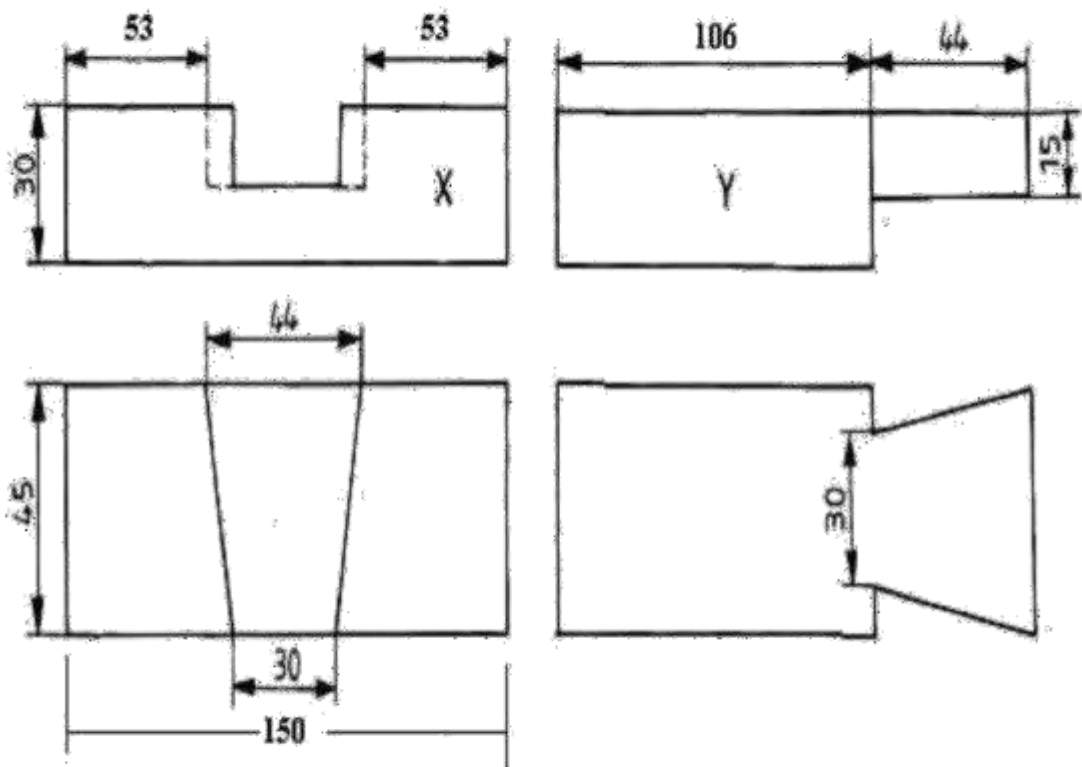

All Dimensions are in "mm"

### VIVA QUESTIONS

1. Plane used for larger surfaces is \_\_\_\_\_
2. A round hole is finished using ( )  
a) Chisel    b) Gauge    c) Rasp file
3. Moisture content in wood is removed by \_\_\_\_\_ .
4. A mortise gauge is used is to draw perpendicular/parallel lines on the stock \_\_\_\_\_
5. \_\_\_\_\_ is used to check squareness and straightness
6. The jaws of a carpenter's vice are lined with metallic/wooden faces ( )
7. \_\_\_\_\_ & \_\_\_\_\_ is used for planing end grains of wood.
8. \_\_\_\_\_ Saw is used for small and thin cuts.
9. Rip saw is used for cutting the stock across/along the grains.
10. Firmer chisel is stronger/weaker than other chisels.
11. \_\_\_\_\_ chisel is convenient for making dovetail joints.
12. The hand tool used for rotating auger bit is called \_\_\_\_\_  
\_\_\_\_\_.
13. Hand drill is used for making ( )  
(a) small holes, (b) big holes, (c) semi –circular, (d) concave grooves.
14. Mallets are made of ( )  
a) soft wood, (b) hard wood, (c) mild steel (d) cast iron.
15. The length of the screw driver is given by its total length, including that the length of its handle (True\ False).
16. \_\_\_\_\_ & \_\_\_\_\_ file is used in carpentry shop for finishing work.
17. In lap joints \_\_\_\_\_ amount of wood is removed from each piece.
18. Mortise Gauge is a ( )  
a) Striking tool    b) Planing tool    c) Marking tool    d) Boring tool
19. Right angles are drawn or tested using ( )  
a) Bevel square    b) Try square    c) Miter square    d) Spirit level
20. Saw used for fine work is ( )  
a) Tenon saw    b) Jack saw    c) Rip saw    d) Dovetail saw

## FITTING

### INTRODUCTION:

Machine tools are capable of producing work at a faster rate, but there are occasions when components are processed at the bench. The term bench work refers to the production of components by hand on the bench, whereas fitting deals with the assembly of mating parts, through removal of metal to obtain the required fit. Both the bench work and fitting operations consist of filing, chipping, sawing, drilling, tapping etc.

### CLASSIFICATION OF TOOLS:

The tools commonly used in fitting may be classified as

Work holding tools

Cutting tools

Striking tools

Marking and checking tools

### WORK HOLDING TOOLS:

a) Bench vice b) Hand vice c) Pipe vice d) Pin vice e) Tool makers vice f) Leg-vice g) C-clamp

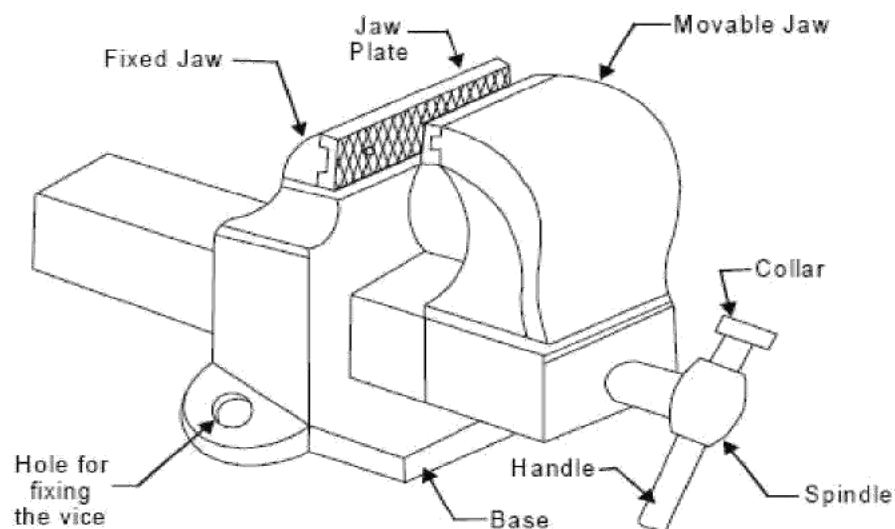

A bench vice

### A. BENCH VICE:

The bench vice is a work-holding device. It has two jaws one of which is fixed to the bench and other slides with aid of square screw and a box nut arrangement. The outer end of screw

carries a handle. The jaws are made with hardened steel and body is cast iron or cast steel.

The working faces of jaws are serrated to give additional grip for holding.

- Square file-----Used for slots and key ways.
- Triangular file-----Used for sharp corners
- Half round file-----Used for filing concave surfaces and internal corners.
- Round file----- Used for deep hole filing

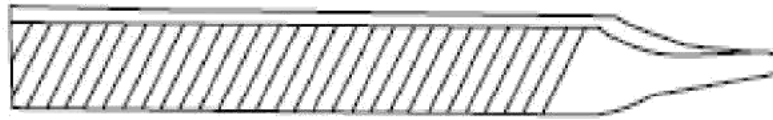

1. Hand file

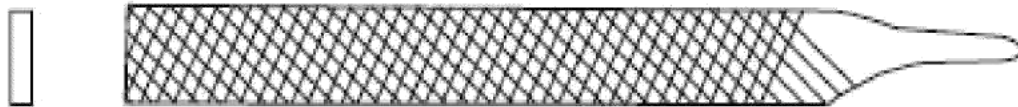

2. Flat file

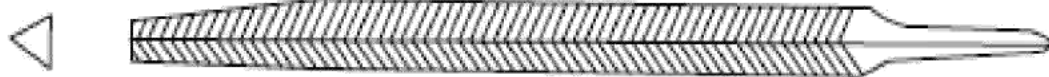

3. Triangular file



4. Round file

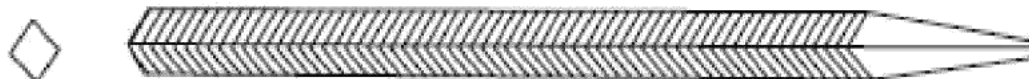

5. Square file



6. Half round file

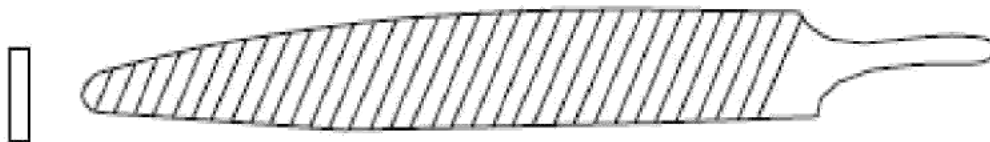

7. Knife Edge file



8. Pillar file



9. Needle file



## SQUARE FIT

**Expt No:**

**Date:**

**Aim:** To make a square fitting of dimensions 48x48x6mm with the given MS flat material piece.

**Tools required:** Steel rule, Try square, 12inch Rough file, 8 inch Smooth file with safe edge, Scriber, Dot punch, Hack saw frame with blade, Ball peen hammer, Odd leg caliper, Surface gauge and V-Block.

**Sequence of operations:**

1. Filing
2. Marking
3. Punching
4. Cutting
5. Filing
6. Finishing

**Procedure:**

**Result:**

**Precautions:**

1. Wear tight overalls & safety shoes.
2. Position the job very close to the vice jaw to prevent springing, saw breakage and personnel injury.
3. Apply force only on the forward stroke while cutting.
4. See that the handle of the hammer is tightly wedged.
5. Remove sharp projecting edges and burrs, which produce inaccuracies in layouts, measurement errors & improper fits.

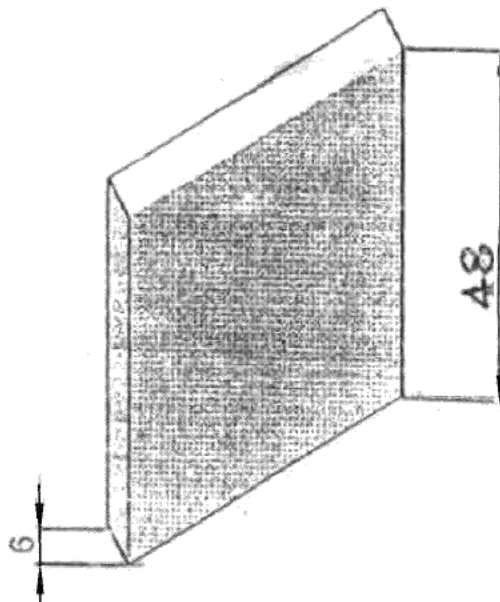
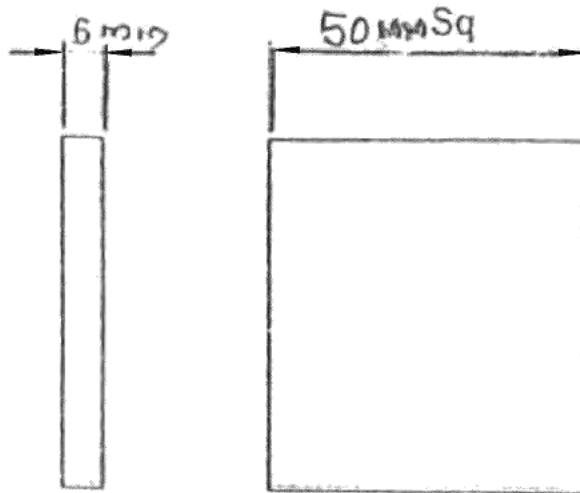

## STRAIGHT FIT

**Expt No:**

**Date:**

**Aim:** To make a straight fitting of dimensions as per the sketch with the given MS flat material pieces.

**Tools required:** Steel rule, Try square, 12inch Rough file, 8 inch Smooth file with safe edge, Scriber, Dot punch, Hack saw frame with blade, Ball peen hammer, Odd leg caliper, Surface gauge and V-Block.

**Sequence of operations:**

1. Filing
2. Marking
3. Punching
4. Cutting
5. Filing
6. Finishing.

**Procedure:**

**Result:**

**Precautions:**

1. Wear tight overalls & safety shoes.
2. Position the job close to the vice jaw to prevent springing, saw Breakage & personnel injury.
3. Apply force only on the forward stroke while cutting.
4. See that the handle of the hammer is tightly wedged.
5. Remove sharp projecting edges and burrs, which produce inaccuracies in layouts, measurement errors & improper fits.

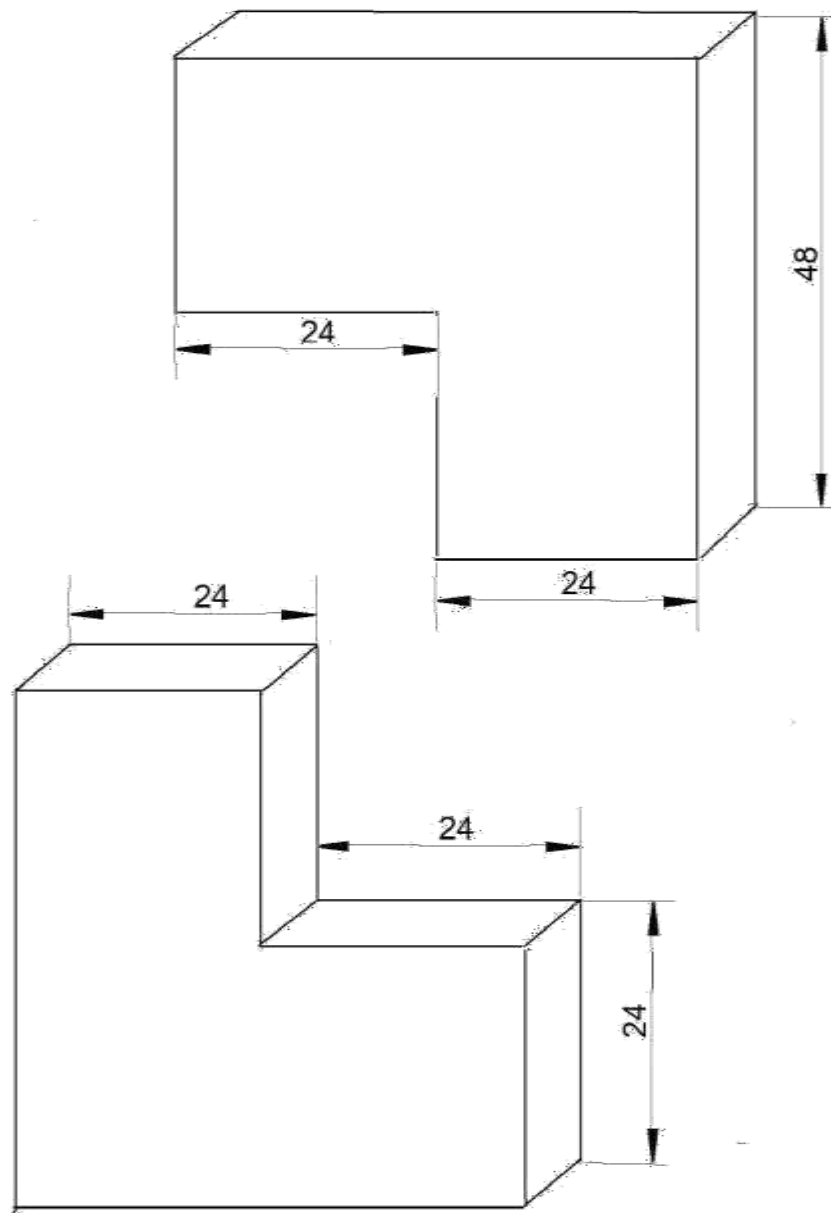

## **VIVA QUESTIONS**

1. The size of vice is specified by the length of the \_\_\_\_\_
2. \_\_\_\_\_ are provided on the jaws of the bench vice, to ensure good grip.
3. Cast iron is strong in \_\_\_\_\_ and weak in \_\_\_\_\_.
4. \_\_\_\_\_ & \_\_\_\_\_ & \_\_\_\_\_ is used to support round stock for layout and inspection.
5. The angle of V-block is usually , (a)45° ,(b) 60° ,(c)90° , (d)120°
6. Try-square may be used as a measuring and marking tool for 90° angle.
7. \_\_\_\_\_ is used to mark or scribe lines on metal work pieces.
8. Odd leg caliper is also called as \_\_\_\_\_ or \_\_\_\_\_
9. The dot punch has a sharper point than a centre punch.
10. Calipers are direct/indirect measuring tools.
11. Vernier calliper s can be used for measuring inside dimension accurately.  
(True/False)
12. A hacksaw blades is so fitted in its frame , that it cuts on the \_\_\_\_\_ stroke.
13. Hacksaw blades having lesser number of teeth per centimetre are used for cutting \_\_\_\_\_ materials.
14. The \_\_\_\_\_ of the teeth keeps the hack-saw blade from binding in the cut .
15. Combination piler is used for \_\_\_\_\_ material.
16. A tap is used for cutting external threads. (True/False)
17. The finishing tap is known as \_\_\_\_\_ tap.
18. Dies are used for making external threads. (True/False)
19. The edge of a file that does not have a teeth on it is called a \_\_\_\_\_.
20. The shape of the file to be used on a job depends upon the amount of material to be removed (True/False)

## TIN SMITHY

### INTRODUCTION:

The metal plank having less than 2 mm thickness is called sheet metal. Sheet metal work deals with the production of components in wide variety of shapes and sizes from sheet metal, with aid of tools or machines metals used in sheet metal work variety of metal shop. The characteristics and uses of some of the important metals used in sheet metal work are described below:

**Galvanized iron:** It is a sheet of soft steel, which is coated with zinc. Zinc resists corrosion and improves the appearance of metal. Galvanized iron is one of the least expensive metals and is used for making pans, buckets, ducts, gutters, tanks, boxes, etc.

**Black iron:** It is uncoated sheet of metal with bluish-black appearance. It corrodes rapidly and is not used extensively due to difficulties of soldering. The black iron sheets are used for the parts that are to be painted.

**Tin plate:** Tin plate is an iron or steel coated with pure tin. It has very bright silver appearance and is used for food containers, cans and pans.

**Stainless steel:** It is an alloy steel possessing corrosion resistance. General type stainless steel contains 18 percent chromium and 8 percent nickel. This steel is commonly known as 18-8 stainless steel. These are available in various sizes and thickness. It is widely used for food containers and dairy equipment.

**Copper:** It has reddish color and possesses good malleability, ductility and resistance to atmospheric corrosion.

**Aluminium:** Sheet aluminium is never pure aluminium and it is always alloyed with small quantities of copper silicon, magnesium and iron.

### CO RELATION BETWEEN TINSMITHY AND ENGINEERING DRAWING:

In Tin Smithy we make different surface models using metal sheets. Here we use the techniques of engineer drawing (development of surfaces) to cut the metal sheet. Using development of surfaces technique in engineering we can obtain the size and shape to the sheet required to produce that object which results in reduction of scrap.

### TOOLS AND EQUIPMENT:

Some of the tools used in fitting are also used in sheet metal work. Certain additional tools used by sheet metal worker are described below:

**Snips:** Hand shears or snips are used to cut sheet metal. Although there are many types, the sheet metal workers generally use straight snips and curved snips.

**Bench shears:** Bench shear is used for cutting thicker sheets. It is the lower fixed blade firmly secured by bracket at the bottom. The movable blade is pivoted at the rear end; the hand operating lever is attached to the front end of movable blade in a link mechanism.



Straight hand shear



Universal shear



Curved hand shear

**Stakes:** Stakes are made of steel and forged in a variety of shapes and sizes. Its working face is machined and polished to facilitate various operations such as bending, seaming or forming.

The following types of stakes are most generally used:

**Double seaming:** These stakes has two horns and it is used to make double seam for vessels.

**Blow horn:** These stakes has two horn tapering horns and it is used to form or seam funnels.

**Break horn:** These stakes has a square tapered horn on one side and a round tapered horn on opposite side. It is used for shaping round and square surfaces, bending edges and making corners.

**Conductor stake:** These stakes has two cylindrical horns having different diameters. It is used for forming pipes and cylindrical pieces.

**Funnel stake:** It is used for forming conical shapes and for making wire rings.

**Hatchet stake:** It has a horizontal sharp straight edge and can be used for making straight, sharp bends and for folding and bending edges.

## ROUND TIN

**Expt No:**

**Date:**

**Aim:** To make a Round tin of dimensions as per the given sketch with the given G I Sheet.

**Tools required:** Steel rule, Vernier caliper, scribe, divider, Punch, Chisel, Hammer, Mallet, Shears/snips, Pliers, Stakes, Soldering iron, Shearing machine.

**Sequence of operations:**

1. Marking
2. Shearing
3. Bending
4. Folding
5. Squeezing & pressing
6. Soldering

**Procedure:**

**Result:**

**Precautions:**

1. Wear tight overalls & safety shoes.
2. See that the handle of the hammer is tightly wedged.
3. Draw the pattern of correct dimensions giving due allowances for making joints.
4. Take care while using shear/snip or shearing machine to avoid personnel injury.



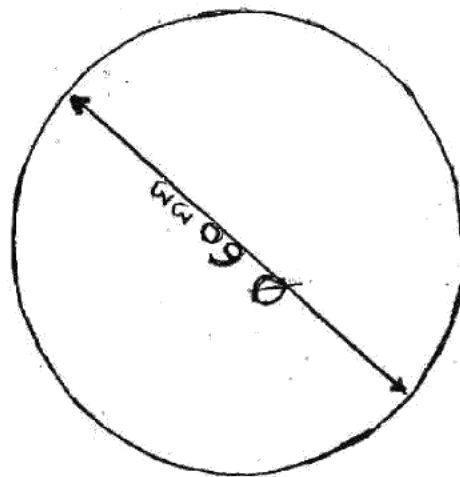
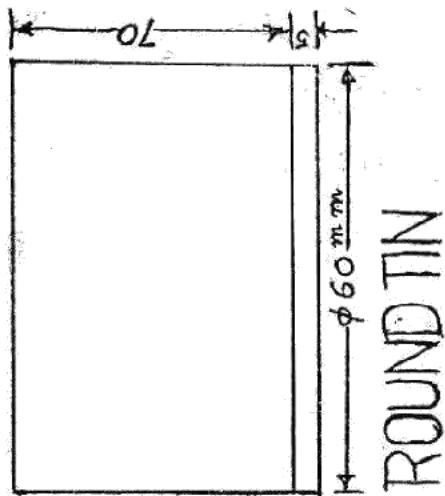
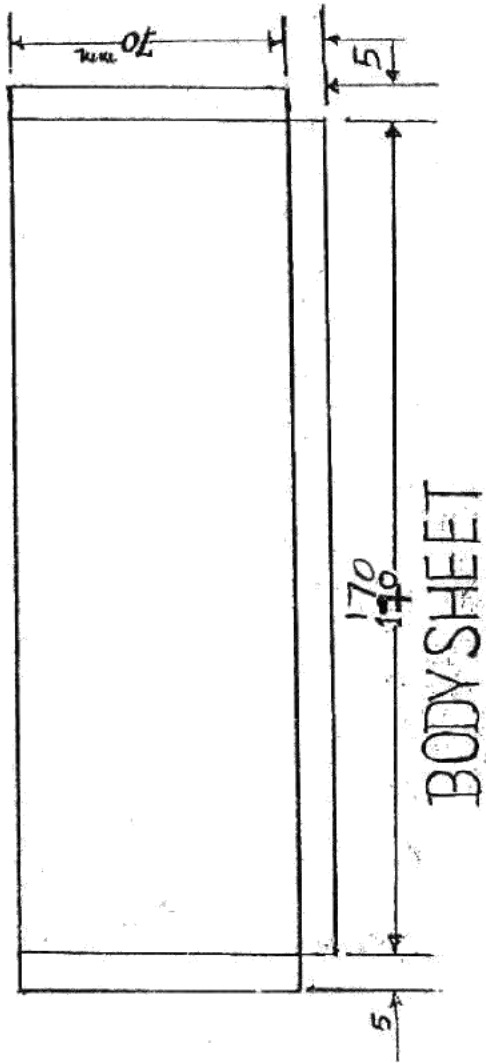

## RECTANGULAR TRAY

Expt No:

Date:

**Aim:** To make a rectangular tray of dimensions as per the given sketch  
With the given G.I. Sheet.

**Tools required:** Steel rule, Vernier caliper, scribe, divider, punch,  
Chisel, Hammer, Mallet, Shears/Snips, Pliers,  
Stakes, Soldering iron, Shearing machine.

**Sequence of operations:**

|             |                         |
|-------------|-------------------------|
| 1. Marking  | 4. Folding              |
| 2. shearing | 5. Squeezing & Pressing |
| 3. Bending  | 6. Soldering            |

**Procedure:**

**Result:**

**Precautions:**

1. Wear tight overalls & safety shoes.
2. See that the handle of the hammer is tightly wedged.
3. Draw the pattern of correct dimensions giving due allowance for making joints.

4. take care while using shear/snip or shearing machine to avoid personal injury.

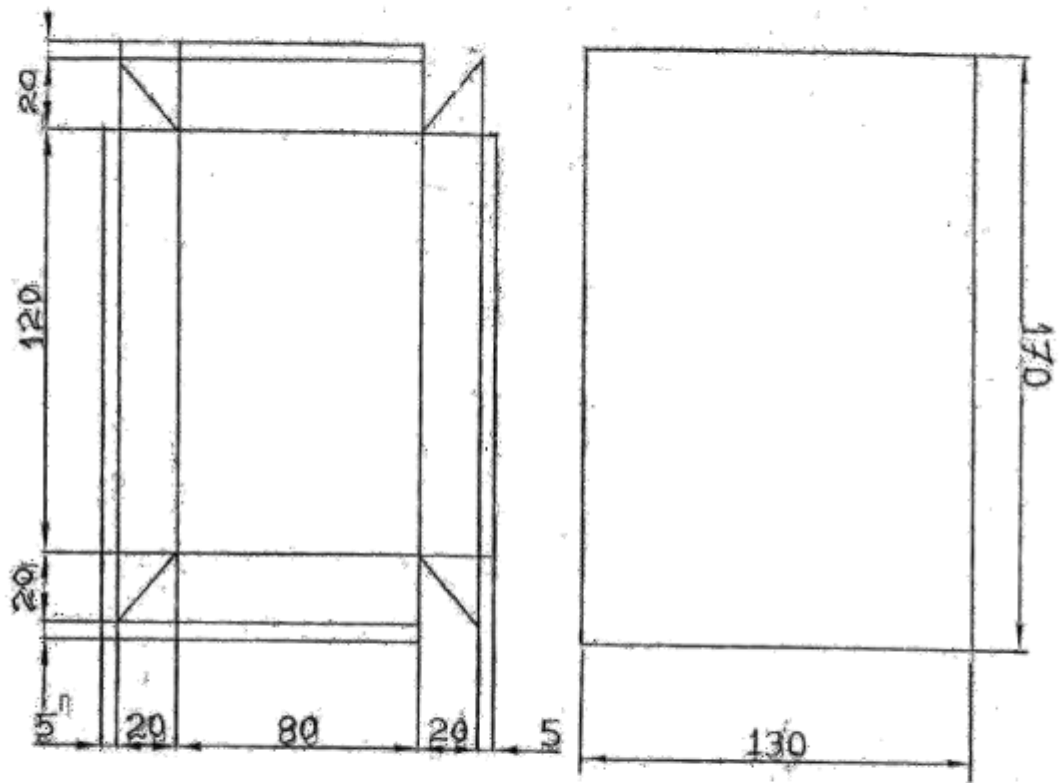

DEVELOPMENT

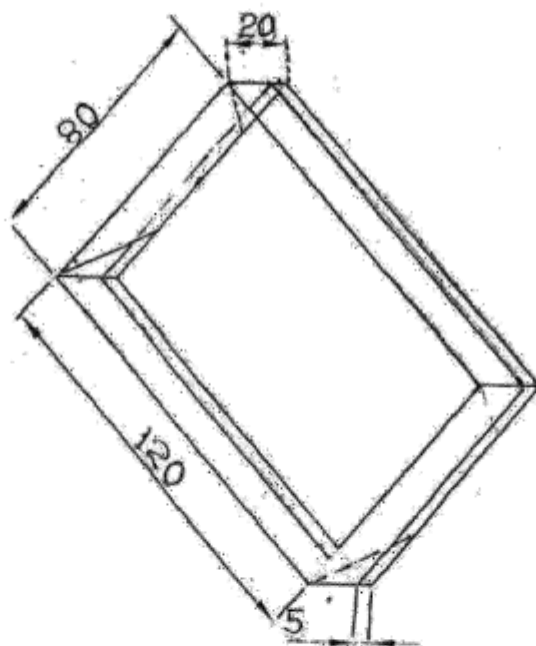

RECTANGULAR TRAY

## HOUSE WIRING

### INTRODUCTION:

Electrical wiring is defined as a system of electrical conductor, components and apparatus for conveying electric power from the source to the point of use. Power is supplied domestic installation through a phase and a neutral forming a single phase AC 230 V two wire system. For industrial establishment, power is supplied through three-phase wire system to give 440 V. The neutral is earthed at the distribution substation of the supply. When supplied to domestic utilities, phase is fed to a kilowatt meter and then to a distribution panel. The panel distribution passes along with circuits.

### ELEMENTS OF HOUSE WIRING:

#### 1. Fuses and circuit breakers:

These are devices designed to provide protection to a circuit against excess current.

#### 2. Electric Switch:

This is a device that makes and breaks or changes the course of electric circuit.

#### 3. Plug:

It is a device carrying two or three metallic contacts in the form of pins, intended for engaging with corresponding socket contacts and arranged for attachment to appliances such as radio, T.V., Fan etc.

#### 4. Socket out let:

It is a device carrying two or three contact designed for engagement with corresponding plug pins and arranged for connection to fixed wiring.

#### 5. Lamp Holder:

Lamp Holder is designed to hold lamps and connect there in the circuit.

#### 6. Main Switch:

This is a switch intended to connect or cut off the supply of the electricity to the whole of insulation. It contains one or more fuses.

### COMMON HOUSE WIRING CONNECTIONS:

- One lamp controlled by a one-way switch:

Figures show the wiring diagram for a lamp controlled by a one-way switch. This is the normal connection one comes across in house wiring.

- Two lamps connected in series or parallel by a one-way switch:

- Two lamps may be connected by one-way switch in parallel for bright glow or in series for dull glow.
- One lamp controlled by 2 two-way switches:

It is sometimes desirable to control a lamp from two different places. One may come across this situation with staircase, long corridors or hall containing two entrances etc.

**Combination Piler:** It is made of steel and its size is given according to fix length. It has a cutter for cutting the wires.

**Electrician knife:** It is the tool used for removing the insulation from the wires. It has two folding blades, one for removing the insulation and the other for clearing the wires.

**Test Lamp:** A test holder with a lamp is called a test lamp. It is used for testing the supply.

**Pocker:** It is long sharp tool used for making pilot holes in wood before fixing and tightening of wood screws.

**Rawl plug tool and bit:** It has two parts namely the tool bit and tool holder. The tool bit is made of carbon steel and the tool holder is made of mild steel. It is used for making holes in brick and concrete walls or ceilings. Its size depends upon the number, as the number increases; the thickness of the bit as well as the plug also increases.

**Ball peen Hammer:** There are different types of hammers used for different purposes. The purpose of ball peen hammer is generally used in electrical trades. The size of hammer is usually indicated by its weight.

**Electric soldering Iron:** It is used for soldering wires to commutator segments and small joints with solder. It consists of pointed oval copper bit fixed to an iron rod which is heated by an electric element only.

## EXPERIMENT – 01:

**AIM:** To prepare a wiring to control two lamps connected in series by one switch. (SERIES CONNECTION)

**TOOLS REQUIRED:**

1. Screw driver,
2. Connector,
3. Tester,
4. Lamp holders,
5. One way switch, wires,
6. Wire clips,
7. Nails, Pocker,
8. Bulbs,
9. Wire cutter,
10. Nose plier,
11. Cutting plier,
12. Ball peen hammer.

**CIRCUIT DIAGRAM:**

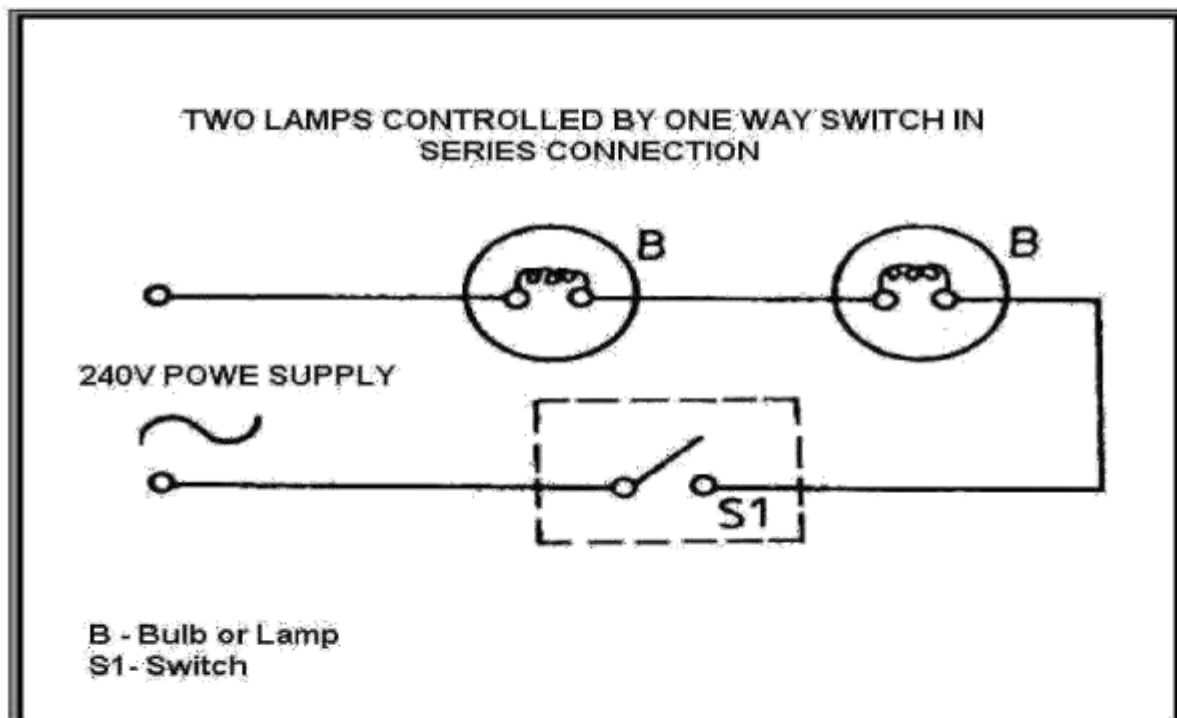

## **SEQUENCE OF OPERATIONS:**

## **PRECAUTIONS:**

1. Never remove a plug from an outlet by pulling the cord. Always pull by the plug.
2. Whenever there is power failure, put off the power supply to all equipment in order to prevent spontaneous recovery.
3. Put on mains only ascertaining completion of correct wiring.

## **RESULT:**

## EXPERIMENT

**AIM:** To prepare a wiring to control two lamps connected in parallel by one switch.

(PARALLEL CONNECTION)

### TOOLS REQUIRED:

1. Screwdriver
2. Connector
3. Tester
4. Lampholders
5. One wayswitch
6. Wires
7. Wireclips
8. Nails
9. Pocker
10. Bulbs
11. Wirecutter
12. Nosepliers
13. Cuttingpliers
14. Ball peenhammer

### CIRCUIT DIAGRAM:

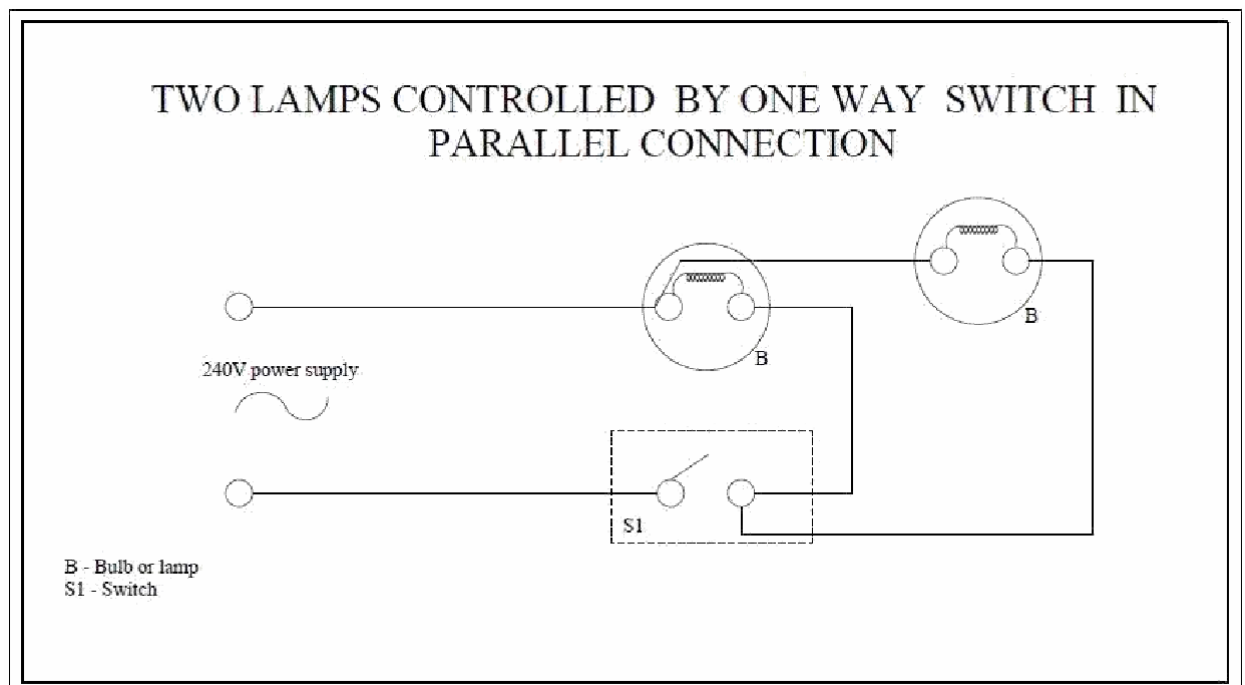



## **SEQUENCE OF OPERATIONS:**

## **SAFETY PRECAUTIONS:**

1. Never remove a plug from an outlet by pulling the cord. Always pull the plug.
2. Whenever there is power failure, put off power supply to all equipment in order to prevent spontaneous recovery.
3. Put on mains only after ascertaining completion of correct wiring.

## **RESULTS:**

## EXPERIMENT

**AIM:** To prepare a wiring to control one lamp controlled by two way switch.

### TOOLS REQUIRED:

1. Screwdriver
2. Connector
3. Tester
4. Lampholders
5. One wayswitch
6. Wires, wireclips
7. Nails
8. Pocker
9. Bulbs
10. Wirecutter
11. Nosepliers
12. Cuttingpliers
13. Ball peenhammer

### CIRCUIT DIAGRAM:

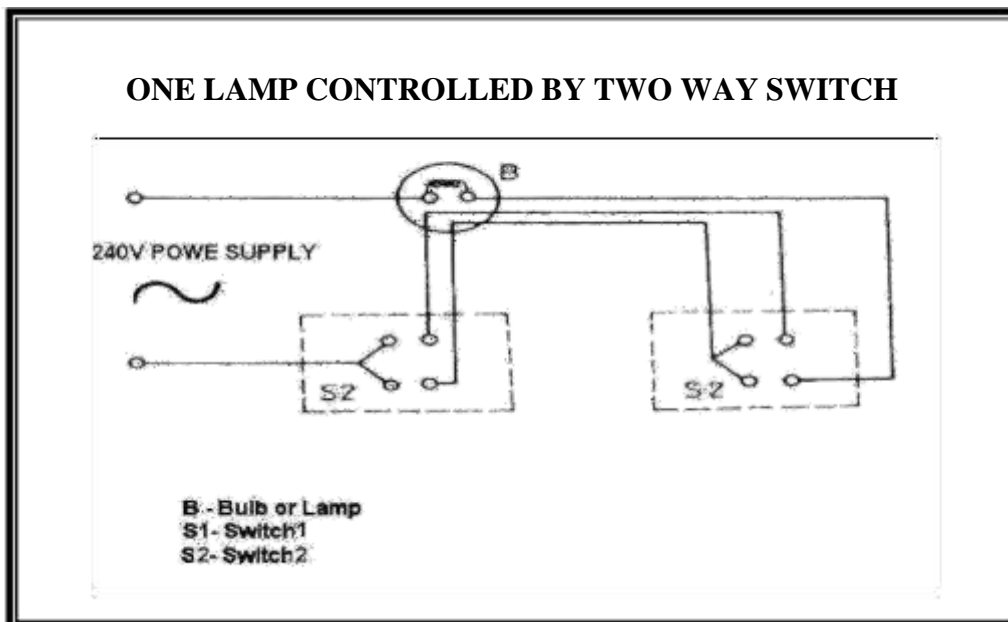

## **SEQUENCE OF OPERATIONS:**

## **PRECAUTIONS:**

1. Never remove a plug from an outlet by pulling the cord. Always pull the plug.
2. Whenever there is power failure, put off power supply to all equipment in order to prevent spontaneous recovery.
3. Put on mains only after ascertaining completion of correct wiring.

## **RESULTS:**

### VIVA QUESTIONS (HOUSE WIRING)

1. For domestic use, power is supplied through a \_\_\_\_\_ and a \_\_\_\_\_, forming a single phase A.C, two wire system.
2. For industrial establishments power is supplied through \_\_\_\_\_ phase, \_\_\_\_\_ wire system.
3. Electric switch \_\_\_\_\_ and \_\_\_\_\_ the electric circuit.
4. A plug engages with corresponding \_\_\_\_\_ contacts.
5. Main switch is used only to cut –off the supply of electricity.
6. A lamp filament is made of \_\_\_\_\_.
7. A multicore conductor consists of several cores \_\_\_\_\_ from each other.
8. Wire sizes are specified by the diameter/length of the wire.
9. The wire specification 14/36 indicates \_\_\_\_\_ strands of \_\_\_\_\_ SWG.
10. In series circuit, when one device breaks down; the remaining devices operate (True/False)
11. In parallel circuit, if one device breaks down; the remaining devices operate. (True/False)
12. Regulator is used for controlling the \_\_\_\_\_ of a fan.
13. Universal fans operate both on A.C and D.C (True /False)
14. While using a table fan, always use two/three core flexible wire for connection.
15. If the bulb on the handle of an automatic electric iron glows, it means that the iron is cool/hot.
16. The intensity of the glow of an indicator lamp is a measure of a voltage/current level.

## FOUNDRY

### INTRODUCTION:

Metal casting is the process of forming metallic objects by melting metal, pouring it into the shaped cavity of a MOULD and allowing it to solidify. The process of casting involves the basic operations of pattern making, sand preparation, MOULDING, melting of metal, pouring in moulds, cooling, shake-out, felting, heat treatment, finishing and Inspection. The casting process involving the use of sand as moulding medium can be classified as sand moulding processes. The stages involved in the sand moulding processes are: Sand preparation, pattern making, core making (if required), moulding and closing.

### PREPARATION OF A MOULD (fig 1)

1. The following are the steps used in making a simple mould using a hollow split pattern with core prints on both sides:
2. Place the bottom half of the pattern on the moulding board, with its flat side on the board.
3. Place the drag over the board.
4. Sprinkle the pattern and the moulding board with parting sand.
5. Allow facing sand, over the pattern, until it is covered to a depth of 2 to 3 cm.
6. Pack the moulding sand around the pattern into the corners of the flask with fingers.
7. Place backing sand in the flask and ram the sand in the moulding box with a rammer.
8. Use first the peen end and then the butt end of the rammer.
9. Strike off the excess sand from the top surface of the drag with strike off bar.
10. Turn the drag upside down.
11. Blow-off the loose sand particles with the bellows and smoothen the upper surface.
12. Align top half of the pattern with the bottom half by means of dowel pins.
13. Place the cope on the top of the drag in position, Locate riser on the highest point of the pattern.
14. Place the sprue pin 5 to 6cm away from the pattern on the other side of the riser pin.
15. Sprinkle the upper surface, over and around the pattern with the parting sand.
16. Repeat steps 4 to 7, appropriately.
17. Make holes with the vent rod to about 1cm from the pattern.
18. Remove the sprue and riser pins by carefully drawing them out. Make a funnel shaped hole at the top of the sprue hole, called the pouring basin.
19. Lift the cope and place it aside on its edge.

## WHEEL FLANGE

**Expt No:**

**Date:**

**Aim:** To make a mould from the pattern of Wheel flange

**Tools required:** Moulding board, moulding flask (cope & drag), shovel, rammer, strike off edge, sprue pin, riser pin, trowel, draw pin, slick, gate cutter, vent rod, Moulding sand, chalk/talc powder, molasis.

**Sequence of operations:**

1. Sand preparation
2. ramming
3. Gate cutting
4. Finishing.

**Procedure:**

**Result:**

**Precautions:**

1. The sand prepared should not be too dry or too wet.
2. Molasis/clay should be applied on inner walls of moulding flask properly.
3. Ramming should be done with care when wooden patterns are used.
4. No loose sand should be present

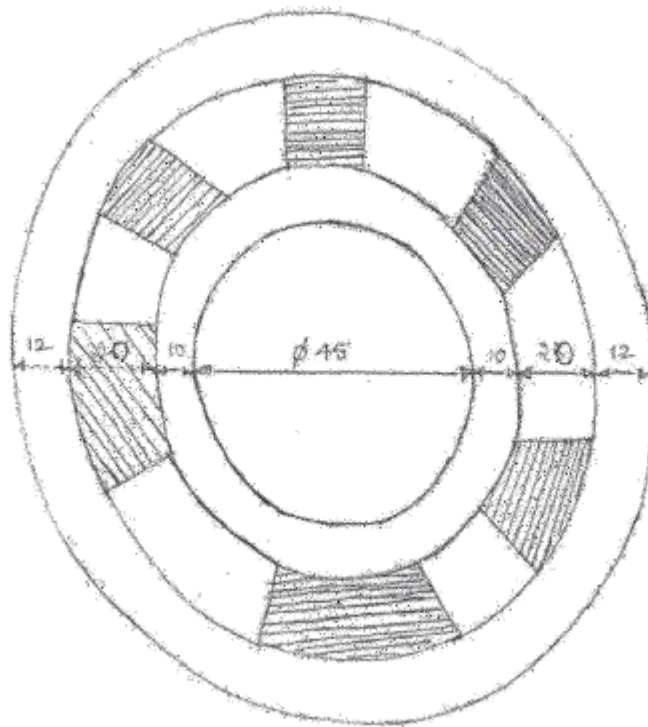
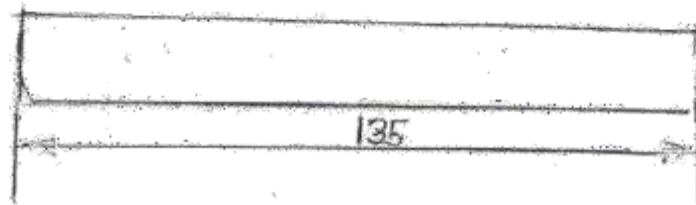

WHEEL FLANGE

## BEARING HOUSING

**Expt No:**

**Date:**

**Aim:** To make a mould from the pattern of bearing housing.

**Tools required:** Moulding board, moulding flask (cope & drag), shovel, rammer, strike off edge, sprue pin, riser pin, trowel, draw pin, slick, gate cutter, vent rod, Moulding sand, chalk/talc powder, molasis.

**Sequence of operations:**

1. Sand preparation
2. ramming
3. Gate cutting
4. Finishing.

**Procedure:**

**Result:**

**Precautions:**

1. The sand prepared should not be too dry or too wet.
2. Molasis/clay should be applied on inner walls of moulding flask properly.
3. Ramming should be done with care when wooden patterns are used.
4. No loose sand should be present inside the mould cavity.



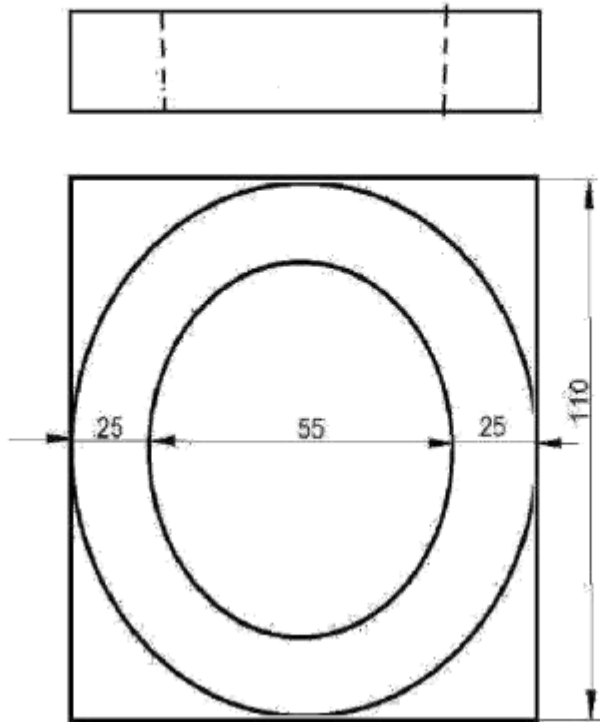

BEARING HOUSING

## **BLACKSMITY**

Forging or Blacksmithy in general refers to the process for the heating of metal in order to manipulate it into desired forms and shapes based on particular concepts or designs. As such, hand forging is still the process of forging metal, only this time the process is manually guided by a forger with the aid of specially designed equipment that are specifically made for such a purpose. Even though hand forging is labor intensive, the process is still favored over machine-produced metals in certain instances due to the perception that it offers some advantages over the other type. The process for hand forging is different from that of machines, and the tools utilized are also different from those used in the mechanized process.

### **HAND FORGING**

The process of hand forging is an ancient one that has been utilized for many centuries by professionals who are generally referred to as blacksmiths. Basically, they shape the metal by heating and applying blows of varying pressure to the metal in order to manipulate it into a desired contour that is keeping with the design the blacksmith is trying to achieve. Apart from the fact that this method of forging metal requires a lot of labor and strength, it also has some benefits over the metals that are forged in other ways. One of the benefits of hand forging is the fact the metal produced through this method is usually stronger than metal produced by other techniques, such as casting or welding. The main reason is that the repeated blows from the blacksmith and the careful monitoring of the process results in a less porous material that is better refined than most tactics.

### **MACHINE FORGING**

A forging machine is also called a press or punch press; the machine presses down on a metal blank and creates a specific shape. Operated in one of three common temperatures — cold, warm and hot —, the designation is keyed to the temperature of the metal being shaped. Using enough pressure to stamp a basic shape from a solid piece of metal in a single strike, the forging machine often operates from a flywheel mechanism that powers a stamping die downward and into the second component piece of the total die, continually pressing due to the inertia of the spinning flywheel. It is a common design trait for a forging machine

## SHAPE – S

**Expt No:**

**Date:**

**Aim:** To make the shape S as per the given sketch with the given MS round rod.

**Tools required:** Smith forge/hearth, anvil, swage block, ball/straight/cross peen hammer, sledge hammer, tongs, chisels, flatters, punch & drift, electric blower, wood coal & railway coal.

**Sequence of operations:**

- 1.Preparation of forge
- 2.Heating and
- 3.Shaping.

**Procedure:**

**Result:**

**Precautions:**

1. Wear tight overalls, safety shoes, goggles and hand gloves.
2. Heated stock should be close to the ground.
3. Hold the job rigidly while shaping.
4. Stand at a safe distance from the forge.
5. The hammer handle should be properly wedged.

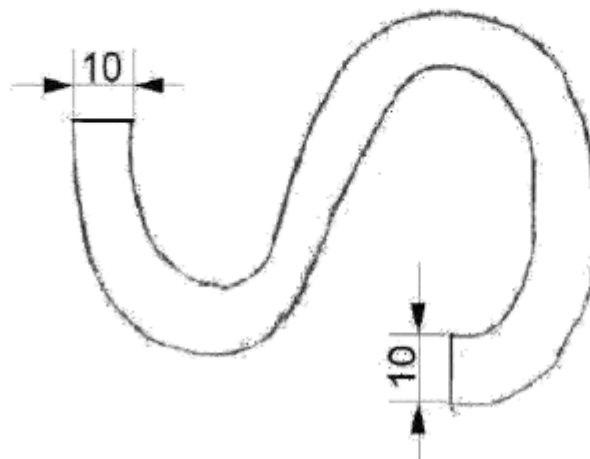
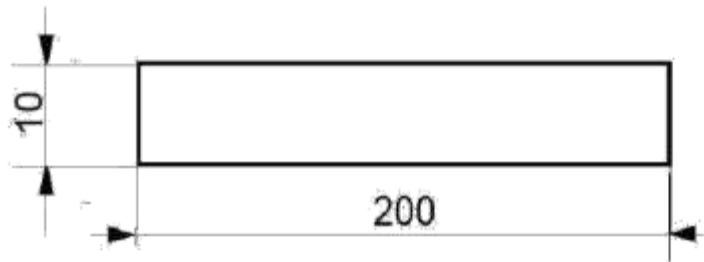

**S - HOOK**

## SHAPE – J

**Expt No:**

**Date:**

**Aim:** To make the shape J as per the given sketch with the given MS round rod.

**Tools required:** Smith forge/hearth, anvil, swage block, ball/straight/cross peen hammer, sledge hammer, tongs, chisels, flatters, punch & drift, electric blower, wood coal & railway coal.

**Sequence of operations:**

- 1.Preparation of forge
- 2.Heating and
- 3.Shaping.

**Procedure:**

**Result:**

**Precautions:**

1. Wear tight overalls, safety shoes, goggles and hand gloves
2. Heated stock should be close to the ground.
3. Hold the job rigidly while shaping.
4. Stand at a safe distance from the forge.
5. The hammer handle should be properly wedged.

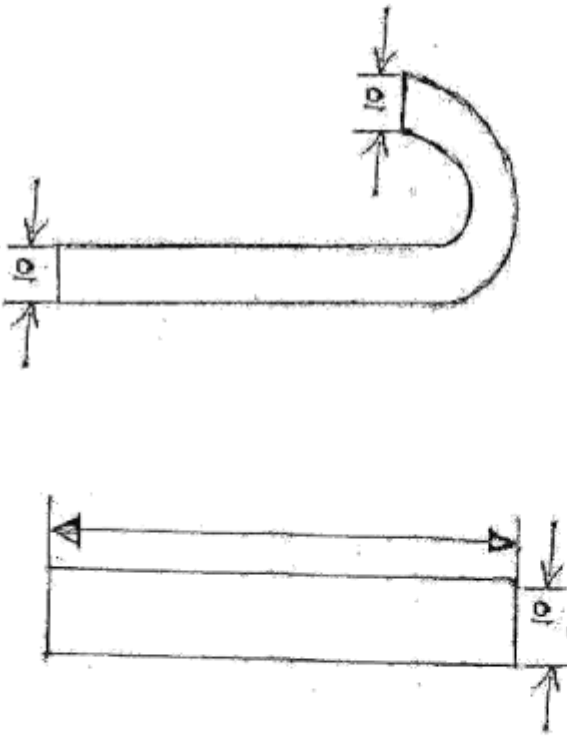

# J- HOOK

## WELDING INTRODUCTION

“Welding” is a metallurgical fusion process, in which the interface of the two parts to be joined are brought to a temperature above the melting point and then allowed to solidify so that a permanent joining takes place. Because of the permanent nature of the joint and strength being equal to or sometimes greater than that of the parent metal makes welding one of the most extensively used fabrication method. Welding is not only for making structures but also for repair work such as the joining of broken castings. Products obtained by the process of welding are called “weldments”.

### **Types of joints:**

Different types of welding joints are classified as but, lap, corner, tee and edge joints. These are shown in fig (1). The choice of the type of the joint depends on the weldment being made and the sheet thickness.

Edge preparation is required, when the thickness of the two pieces to be joined is small, so that heat of welding penetrates the full depth of the joint. However, when the thickness increases it becomes necessary to prepare the edge in such a way that heat would be able to penetrate the entire depth. To facilitate this, the joint is widened as shown in fig (2). For very thick plates, the welding needs to be done from both sides. To provide the necessary access into the joint, it could be made as V or U, as shown in fig (3). The V-joint is easier to make but the amount of extra metal to be filled in the joint increases greatly with an increase in the thickness. From this account a U-joint is preferable, since the amount of extra metal to be added to fill the joint is generally less beyond a certain plate thickness. The double U and double V edge preparations are used when welding is to be carried from both sides.

By virtue of the metal being melted at the interface in a welded joint, it is necessary that the interfaces are very clean. If the interfaces are not clean, with any oil, dirt, paint or grease residue left, then these would interfere with proper fusing of the metal and thus weaken the joint. Hence it is essential that the joint surfaces are thoroughly cleaned before the welding is attempted. Another requirement of welding is a filler metal to fill the gap between the parts to be joined. Ideally the composition of the filler metal should be same as that of the base metals which are being joined, for proper mixing of the filler metal with base metal.

## TERMINOLOGY OF WELDING

- **Backing:** It is the material support provided at the root side of a weld to aid in the control of penetration.
- **Base metal:** The metal to be joined or cut is termed as the base metal
- **Bead or weld bead:** Bead is the metal added during a single pass of welding. The bead appears as a separate material from the base metal.
- **Crater:** In arc welding, a crater is the depression in the weld metal pool at the point where the arc strikes the base metal plate.
- **Deposition rate:** The rate at which the weld metal is deposited per unit time, is the deposition rate is normally expressed as Kg/h.
- **Filled weld:** The metal fused into the corner of a joint made of two pieces placed at approximately 90° to each other [fig. (1)] is termed as fillet weld.
- **Penetration:** It is the depth upto which the weld metal combines with the base metal as measured from the top surface of the joint.
- **Puddle:** The position of the weld joint that melted by the heat of welding is called puddle.
- **Root:** It is the point at which the two pieces to be joined by welding are nearest.
- **Tack weld:** A small weld, generally used to temporarily hold the two pieces together during actual welding is the tack weld.
- **Toe of weld:** It is the junction between the weld face and the base metal.
- **Torch:** In gas welding, the torch mixes the fuel and oxygen and controls its delivery to get the desired flame.
- **Weld face:** It is the exposed surface of the weld.
- **Weld metal:** The metal that is solidified in the joint is called weld metal. It may be only base metal or a mixture of base metal and filler metal.
- **Weld pass:** A single movement of the welding torch or electrodes along the length of the joint which results in a bead, is a weld pass.

**ARC WELDING:** In arc welding the heat required for joining the metals is obtained from an electric arc. Transformers or motor generator sets are used as arc welding machines. These machines supply high electric currents at low voltages and an electrode is used to produce the necessary arc. The electrode serves as the filler rod and arc melts the surfaces so that the metals to be joined are actually fused together. Fig(4) shows the principle of arc welding using a transformer.



## EXERCISE NO.1

### ARC WELDING

#### AIM

To study the effect of arc current on weld strength and heat effected zone in Arc welding and to prepare a double V-butt joint using the given two flat 'L' shaped mild steel pieces by Arc welding process.

#### EQUIPMENT AND MATERIAL REQUIRED:

A.C Welding machine (input supply 230 Volts, single phase, 50 Hz frequency, maximum welding current 150 amps) bench vice, M.S Plates (2 No.s)

#### TOOLS REQUIRED:

Hack saw, electrode holder, electrode, cable and cable connectors, cableplug, chipping hammer, earthing clamp, wire brush, helmet, safety goggles, hand gloves, apron, sleeves etc.

#### PRINCIPLE OF D.C ARC WELDING:

In arc welding, arc is generated between the when these two poles are brought together, and separated for a small distance (1.5 to 3mm) such that the current continues to flow through a path of ionized particles, called plasma, an electric arc is formed. Since the resistance of this ionized gas column is high, so more ions will flow anode to the cathode. Heat is generated as the ions strike the cathode.

#### 1. PRINCIPLE OF A.C ARC WELDING:

In A.C arc-welding heat required for welding is obtained from the arc struck between a coated electrode and work piece. The arc heat can be increased or decreased by employing higher or lower arc current. A high arc current with a smaller arc length produces very intense heat

The arc melts the electrode end and the job. Material droplets are transformed from the electrode to the job through the arc and deposited along the joint to be welded. The flux coating melts and produces a gaseous shield and slag to prevent atmospheric contamination of molten weld metal.

#### 2. STRAIGHT POLARIT:

In straight polarity, electrode is having negative terminal while workpiece is connected to the positive terminal of the direct current power source

#### 3. REVERSE POLARITY:

In reverse polarity, electrode is connected to positive terminal whereas workpiece is connected to the negative terminal of the direct current power source.

#### DESCRIPTION OF EQUIPMENT:

Arc welding setup is shown in the fig. The work piece is kept on a metallic table to which the ground lead of the secondary windings of the welding transformer is connected. The other lead of the secondary is connected to an electrode holder. Into which the electrode is gripped. When the electrode is

4 |

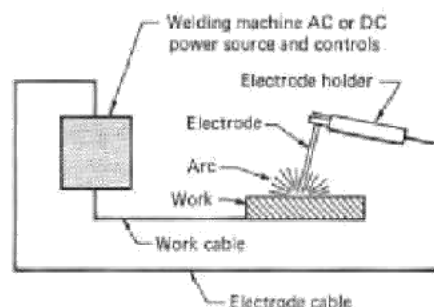

brought into the contact with the work then welding will takes place.

The maximum rated open circuit voltage, which is the voltage between the output terminals when no welding is being done. It is normally fixed at about 80 volts. This is the maximum normally a voltage of the order of the 40 to 50 volts is enough to starting an arc, where as for continuous welding 20 to 30 V is sufficient.

The minimum welding load voltage can be calculated as

$$V_m = 20 + 0.4I$$

Where I=load current in amperes.

The duty cycle as defined by American Welding Society (AWS) is "the percentage of time in a 10 min. period, that a welding machine can be used at its rated output without overloading". Most of the welding machines need not to have to operate the full time, since a good length of time is spent in setting up, metal chipping, cleaning and inspection.

Normally a 60% duty cycle is suggested. The Indian standard specific 5 min. as the cycle and hence for every 5 min. of welding transformer operation, 3 min. is for welding and 2 min is for no loading operation. But continuous, automatic-welding machines may require the welding machine to operate at 100% duty cycle.

#### **PROCEDURE:**

1. Given two MS plates are filed at an angle of  $45^\circ$  at the surface to be joined.
2. Now the pieces are placed on table at some gap and weld properly for both sides.
3. After welding let it cool (quenching) sometime in the water and remove the slag formation with the help of chipping hammer.

#### **PRECAUTIONS:**

1. Edge preparation should be done very carefully.
2. Before welding ensure that the surfaces are extremely clean
3. While welding always use face shield or goggles
4. Note the current values carefully

#### **RESULT:**

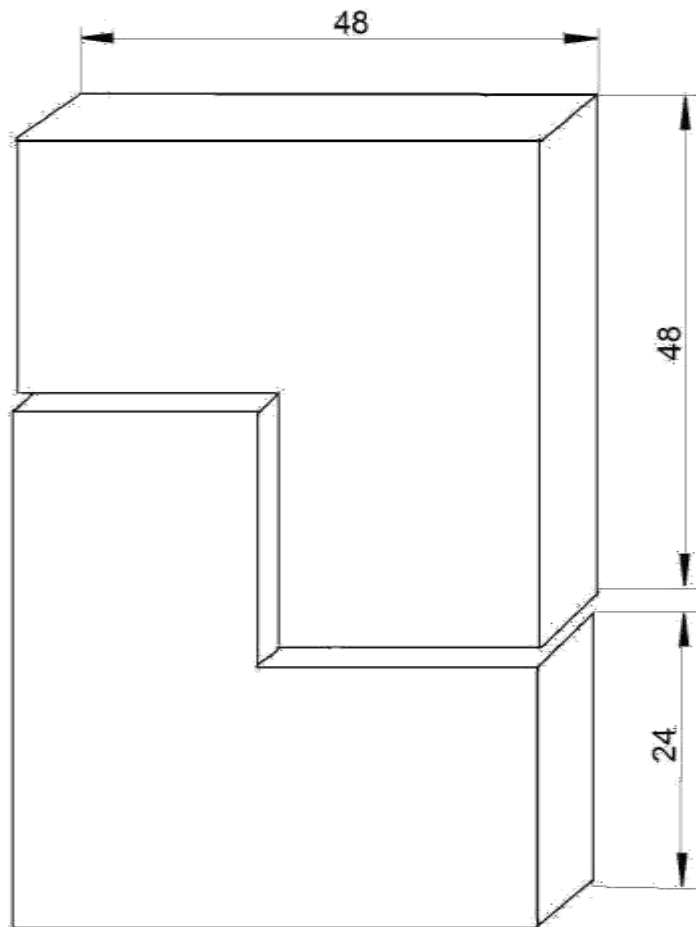

## ARC WELDING

## EXERCISE NO.2

### GAS WELDING (OXY-ACETYLENE)

#### AIM

To make a butt joint by using gas welding equipment.

#### GAS WELDING EQUIPMENTS:

1. **Oxygen gas cylinder:** oxygen cylinders are painted black and valve outlets are screwed right-handed.
2. **Acetylene gas cylinder:** Acetylene cylinder is painted maroon and the valves are screwed left-handed, to make this easily recognizable, they are chamfered or grooved.
3. Oxygen and Acetylene pressure regulators.
4. Oxygen and Acetylene gas hoses and hose connections
5. Welding torch or Blowpipe
6. Trolleys for the transportation of oxygen and acetylene cylinders
7. Set of keys and spanners
8. Filler rods and fluxes
9. Gas lighter
10. Protective clothing for the operator (e.g apron, gloves, goggles etc..)

#### MATERIAL REQUIRED:

M.S Sheets of 100 x 50 x 5mm (2 No.s)

#### TOOLS REQUIRED

Wire brush, hand gloves, chipping hammer, spark lighter.

#### PRINCIPLE OF OPERATION:

When acetylene is mixed with oxygen in correct proportions in the welding torch and ignited, the flame is produced which is sufficiently hot to melt and join the parent metal. Temperature of flame is about  $3100^{\circ}\text{C}$ . a filler rod is generally added to build up the seam for greater strength.

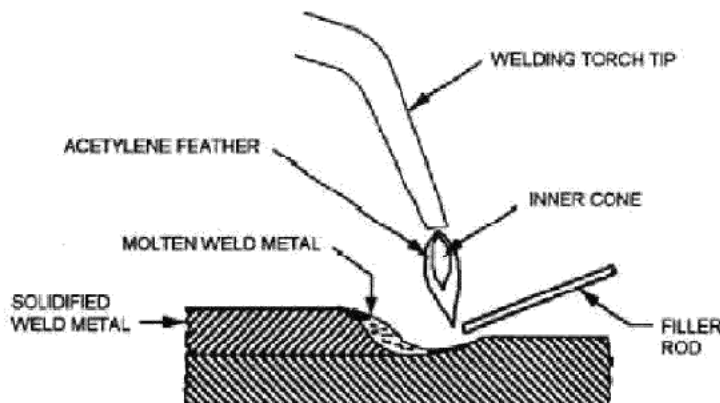

Oxy-acetylene welding outfit contains the supply units for oxygen, acetylene with associated regulators and the torch, which mixes the two gases before they are ignited. The oxygen normally stored in strong cylinder at a pressure ranging from 13.8 MPa to 18.2 MPa. Free acetylene is highly explosive if stored at a pressure more than 200 KPa. Hence, acetylene needs to be carefully stored in a cylinder of the equipment. The principal advantage for an oxy-acetylene welding set up is the versatility of the equipment. The same equipment with a range of torches would be used for oxygen cutting as well as for brazing and braze welding. Thus it is useful for general purpose shops particularly smaller ones. Also the source of heat is separate from the filler rod and hence, the filler metal can be properly controlled and heat is properly adjusted giving rise to a satisfactory weld. However, this method of welding is somewhat slower and as such cannot compete with other production welding methods such as electric arc welding.

#### **ADVANTAGES OF GAS WELDING:**

1. It can be applied to a wide variety of manufacturing and maintenance situations
2. Rate of heating and cooling of weld deposit and job is low
3. No electric current is required
4. Equipment is having less cost
5. Operator is having better control because sources of heat and filler metals are separable
6. Cost and maintenance of the welding equipment is low

#### **DISADVANTAGES OF GAS WELDING:**

1. Flame temperature is less than the temperature of the arc
2. Refractory metals (e.g. tungsten, molybdenum, tantalum etc.) and reactive metals (titanium and zirconium) cannot be gas welded.
3. Gas flame takes a long time to heat up the metal than an arc
4. Heat affected zone is wider
5. Acetylene oxygen gases are rather expensive

#### **APPLICATIONS OF GAS WELDING:**

1. It is used for welding of mild steel, stainless steel, copper, cast iron, high carbon steels, etc
2. For joining thin materials
3. In automotive and aircraft industries
4. In sheet metal fabricating plants

#### **PROCEDURE:**

1. Acetylene valve on the torch is opened slightly and lightened with the help of spark lighter.
2. Now acetylene valve is opened to get the required flow of acetylene.
3. Oxygen valve is opened till the intermediate flame feather reduces in to inner cone to get a neutral flame.
4. The torch tip to be positioned above the plates so that white cone is at a distance of 1.5mm to 3mm from the plates.
5. Torch to be held at an angle of  $30^{\circ}$  to  $45^{\circ}$  to the horizontal plane
6. Now filler rod is to be held at a distance of 10mm from torch flame and 1.5mm to 3mm from the surface of the weld pool
7. As back ward welding allows better penetration, backward welding is to be used for welding
8. After completion of welding slag is to be removed by means of chipping hammer, wire brush.

#### **4 | PRECAUTIONS:**

1. Ensure that torch movement to be uniform.

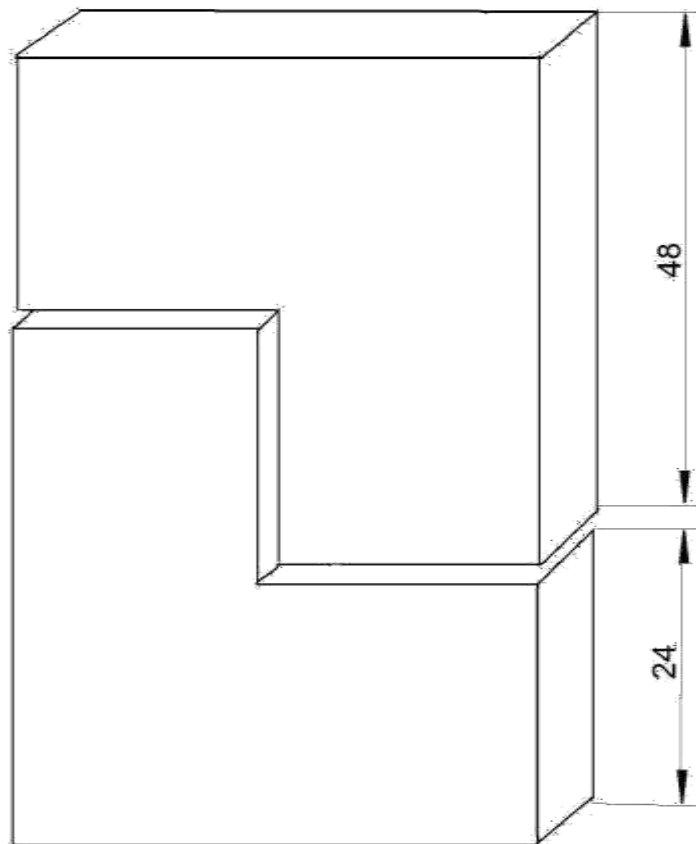

## **GAS WELDING**

## PLUMBING

### INTRODUCTION

It is an art of laying the pipe line for the transportation of fluid from one place to other. So plumbing involves joining of various pipes by different joints and fitting valves in the pipe line. The various tools used for plumbing work are

- 1) Pipe Wrench
- 2) Pipe vice
- 3) Hack Saw
- 4) Pipe Cutter
- 5) Pipe Bender
- 6) Pipe Threading Dies.

**Pipe Wrench:** It is used for holding and turning the pipes, rods and machine parts. It consists of an adjustment of opening between the jaws. For assuring firm grip over pipe the inner surfaces of jaws are serrated.

#### Figure – 1

**Pipe Vice:** It holds the pipes in position cutting threading and fitting of bends, couplings etc, The pipe vice consists of two jaws for holding the work, which are serrated to ensure positive grip. One jaw is integral with the base and the other jaw can be moved up and down by a handle as shown in figure.

#### Figure –2

**Dies:** A pipe die is used for cutting external threads on pipe. One or two piece dies are used in the die stock. It is a hand operated tool. It is a hardened steel nut having flutes cut along its inside surface. In case of two piece die, the two pieces are set at a desired distance and secured in position by means of a set screw.

#### Figure – 3

**Pipe cutter:** For an occasional pipe work, a hacksaw is quite satisfactory. Pipe cutters are also used where considerable amount of pipe work is involved. The pipe cutter mainly consists of three wheels which are hardened and with sharp cutting edges a long their periphery of these three wheels one can be adjusted to any desired distance from the other fixed wheels, to accommodate different sizes of pipes, after adjusting cutter on a pipe, it is turned around the pipe so that cutter wheels cut the pipe along a circle.

#### Figure - 4

**Pipe Bender:** while laying the pipe line sometimes a part of the pipe may have to be bent to the required curvature. For this a pipe bending machine is used. It is mounted on a tripod stand and can be swiveled about a vertical axis to any desired angle to cover the required range for the operation.

#### Figure - 5

# MACHINE SHOP

## INTRODUCTION

Various machining purpose used these all type of mechanical machining machines are Lathe machine, Shaper machine, Slotting machine, Planning machine, Drilling machine, Boring machine, Milling machine, Grinding machine, Lapping machine Honing machine and Broaching machine

These machines are to producing various operations like namely Facing, Chamfering, Step turning, Taper turning, Plain turning, Knurling, Grooving, Thread cutting, Drilling, Tapping, Precision grinding, Cylindrical grinding, Surface grinding, grinding of tool angles e.t.c

## LATHE MACHINE:

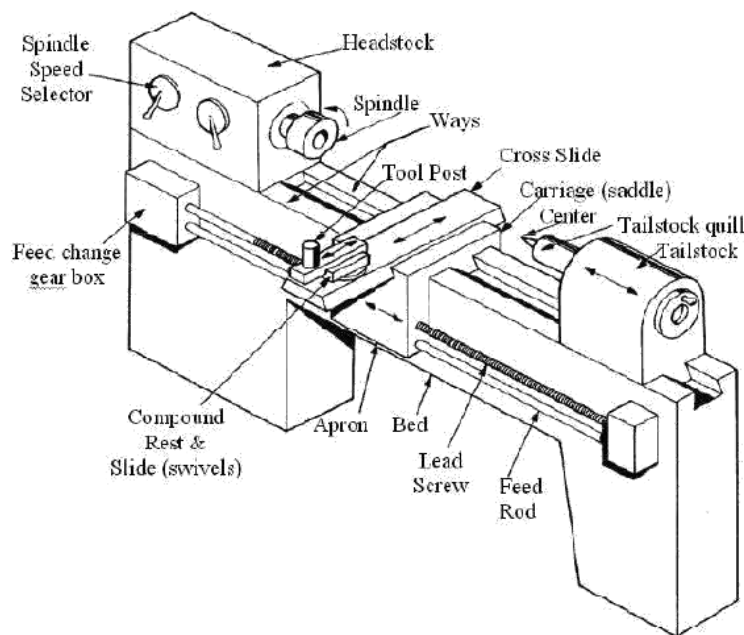

A lathe is a machine tool which rotates the workpiece on its axis to perform various operations such as cutting, sanding, knurling, drilling, or deformation with tools that are applied to the workpiece to create an object which has symmetry about an axis of rotation.

Lathes are used in woodturning, metalworking, metal spinning, and glass working. Lathes can be used to shape pottery, the best-known design being the potter's wheel. Most suitably equipped metalworking lathes can also be



## MILLING MACHINE:

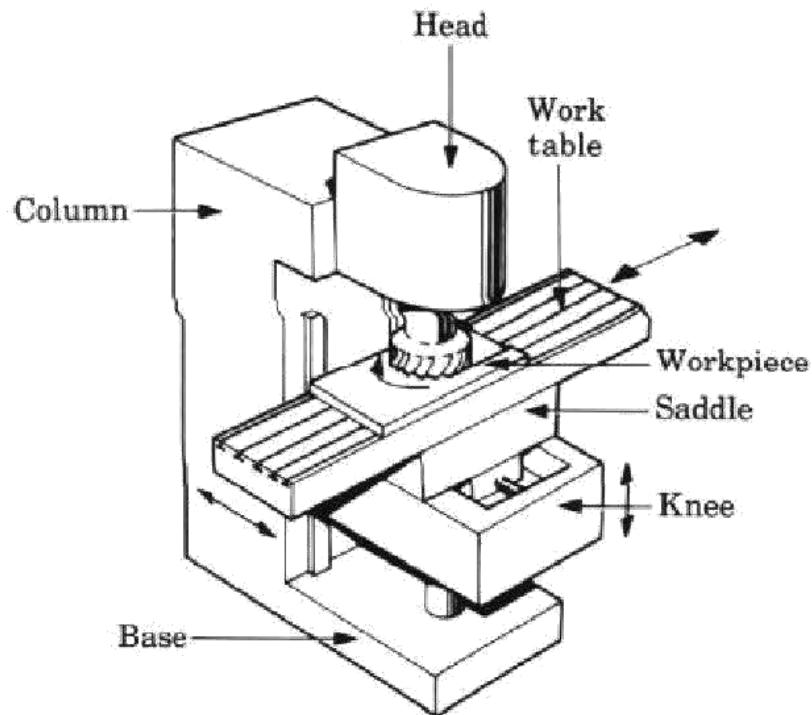

A milling machine (also see synonyms below) is a machine tool used to machine solid materials. Milling machines are often classed in two basic forms, horizontal and vertical, which refers to the orientation of the main spindle. Both types range in size from small, bench-mounted devices to room-sized machines. Unlike a drill press, this holds the workpiece stationary as the drill moves axially to penetrate the material, milling machines also move the workpiece radially against the rotating milling cutter, which cuts on its sides as well as its tip. Workpiece and cutter movement are precisely controlled to less than 0.001 in (0.025 mm), usually by means of precision ground slides and lead screws or analogous technology. Milling machines may be manually operated, mechanically automated, or digitally automated via computer numerical control (CNC).

Milling machines can perform a vast number of operations, from simple (e.g., slot and keyway cutting, planing, drilling) to complex (e.g., contouring, die sinking). Cutting fluid is often pumped to the cutting site to cool and lubricate the cut and to wash away the resulting swarf.