

LECTURE NOTES

ON

CONTROL SYSTEMS

B.Tech IV Semester (AUTONOMOUS)

(Regulation:IARE-R16)

(2018-2019)

Dr Lalit Kumar Kaul
Professor

Dr. K Nehru
Professor

Ms. M L Ravi Teja
Assistant professor

Mr. N Nagaraju
Assistant professor



ELECTRONICS AND COMMUNICATION ENGINEERING
INSTITUTE OF AERONAUTICAL ENGINEERING
DUNDIGAL, HYDERABAD - 500043

CONTROL SYSTEMS

IV Semester: ECE								
Course Code	Category	Hours / Week			Credits	Maximum Marks		
AEE009	Core	L	T	P	C	CIA	SEE	Total
		3	1	-	4	30	70	100
Contact Classes: 45		Tutorial Classes:15		Practical Classes: Nil		Total Classes: 60		
OBJECTIVES:								
The course should enable the students to:								
I. Organize modeling and analysis of electrical and mechanical systems.								
II. Evaluate systems by applying block diagrams, signal flow graphs to study the time response.								
III. Demonstrate the analytical and graphical techniques to study the stability to design the control system.								
IV. Illustrate the frequency domain and state space analysis.								
UNIT-I	INTRODUCTION AND MODELING OF PHYSICAL SYSTEMS						Classes: 08	
Control systems: Introduction, open loop and closed loop systems, examples, comparison, mathematical models and differential equations of physical systems, concept of transfer function, translational and rotational mechanical systems, electrical systems, force voltage and force current analogy.								
UNIT - II	BLOCK DIAGRAM REDUCTION AND TIME RESPONSE ANALYSIS						Classes: 10	
Block Diagrams: Block diagram representation of various systems, block diagram algebra, characteristics of feedback systems, servomotors, signal flow graph, Mason's gain formula; Time response analysis: Standard test signals, shifted unit step, ramp and impulse signals, shifting theorem, convolution integral, impulse response, unit step response of first and second order system, time response specifications, steady state errors and error constants.								
UNIT - III	STABILITY ANALYSIS AND CONTROLLERS						Classes: 09	
Concept of stability: Necessary and sufficient conditions for stability, Routh's and Routh Hurwitz stability criterions.								
Root locus technique: Introduction, root locus concept, construction of root loci, graphical determination of 'k' for specified damping ratio, relative stability, effect of adding zeros and poles on stability.								
Controllers: Proportional, derivative and proportional derivative, proportional integral and PID controllers.								
UNIT - IV	FREQUENCY DOMAIN ANALYSIS						Classes: 10	
Frequency domain analysis: Introduction, frequency domain specifications, stability analysis from Bode plot, polar plot, Nyquist plot, calculation of gain margin and phase margin, determination of transfer function, correlation between time and frequency response.								
UNIT - V	STATE SPACE ANALYSIS AND COMPENSATORS						Classes: 08	
State Space Analysis: Concept of state, state variables and state model, derivation of state models from block diagrams, diagonalization, solving the time invariant state equations, state transition matrix and properties, concept of controllability and observability; Compensators: Lag, lead, lag lead networks.								

Text Books:

1. I. J. Nagrath, M. Gopal, "Control Systems Engineering", New Age International Publications, 3rd Edition, 2007.
2. K. Ogata, "Modern Control Engineering", Prentice Hall, 4th Edition, 2003.
3. N. C. Jagan, "Control Systems", BS Publications, 1st Edition, 2007.

Reference Books:

1. A. Anand Kumar, "Control Systems", PHI Learning, 1st Edition, 2007.
2. S Palani, "Control Systems Engineering", Tata McGraw Hill Publications, 1st Edition, 2001.
3. N. K. Sinha, "Control Systems", New Age International Publishers, 1st Edition, 2002.

Web References:

1. <https://www.researchgate.net>
2. [https:// www.aar.faculty.asu.edu/classes](https://www.aar.faculty.asu.edu/classes)
3. <https://www.facstaff.bucknell.edu/>
4. <https://www.electrical4u.com>
5. <https://www.iare.ac.in>

E-Text Books:

1. <https://www.jntubook.com/>
2. <https://www.freeengineeringbooks.com>

Course Home Page:

UNIT-I

CONTROL SYSTEM MODELING

1.1 Basic elements of control system

In recent years, control systems have gained an increasingly importance in the development and advancement of the modern civilization and technology. Figure shows the basic components of a control system. Disregard the complexity of the system; it consists of an input (objective), the control system and its output (result). Practically our day-to-day activities are affected by some type of control systems. There are two main branches of control systems:

- 1) Open-loop systems and
- 2) Closed-loop systems.

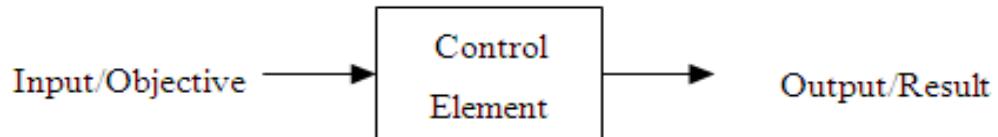

Basic Components of Control System

1.2 Open-loop systems:

The open-loop system is also called the non-feedback system. This is the simpler of the two systems. A simple example is illustrated by the speed control of an automobile as shown in Figure 1-2. In this open-loop system, there is no way to ensure the actual speed is close to the desired speed automatically. The actual speed might be way off the desired speed because of the wind speed and/or road conditions, such as uphill or downhill etc.

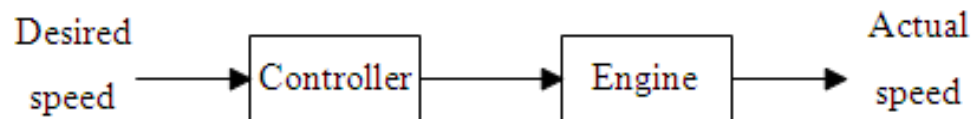

Basic Open Loop System

Closed-loop systems:

The closed-loop system is also called the feedback system. A simple closed-system is shown in Figure 1-3. It has a mechanism to ensure the actual speed is close to the desired speed automatically.

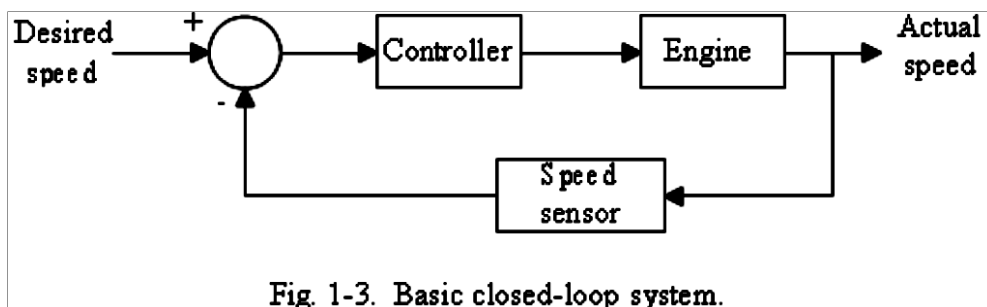

Fig. 1-3. Basic closed-loop system.

Transfer Function

- A simpler system or element may be governed by first order or second order differential equation. When several elements are connected in sequence, say “n” elements, each one with first order, the total order of the system will be nth order
- In general, a collection of components or system shall be represented by nth order differential equation.

$$\frac{d^n y(t)}{dt^n} + a_{n-1} \frac{d^{n-1} y(t)}{dt^{n-1}} + \dots + a_0 y(t) = b_n \frac{d^n u(t)}{dt^n} + \dots + b_0 u(t)$$

- In control systems, transfer function characterizes the input output relationship of components or systems that can be described by Linear Time Invariant Differential Equation
- In the earlier period, the input output relationship of a device was represented graphically.
- In a system having two or more components in sequence, it is very difficult to find graphical relation between the input of the first element and the output of the last element. This problem is solved by transfer function

Definition of Transfer Function:

Transfer function of a LTIV system is defined as the ratio of the Laplace Transform of the output variable to the Laplace Transform of the input variable assuming all the initial condition as zero.

Properties of Transfer Function:

- The transfer function of a system is the mathematical model expressing the differential equation that relates the output to input of the system.
- The transfer function is the property of a system independent of magnitude and the nature of the input.
- The transfer function includes the transfer functions of the individual elements. But at the same time, it does not provide any information regarding physical structure of the system.
- The transfer functions of many physically different systems shall be identical.
- If the transfer function of the system is known, the output response can be studied for various types of inputs to understand the nature of the system.
- If the transfer function is unknown, it may be found out experimentally by applying known inputs to the device and studying the output of the system.

How you can obtain the transfer function (T. F.):

- Write the differential equation of the system.
- Take the L. T. of the differential equation, assuming all initial condition to be zero.
- Take the ratio of the output to the input. This ratio is the T. F.

Mathematical Model of control systems

A control system is a collection of physical object connected together to serve an objective. The mathematical model of a control system constitutes a set of differential equation.

1. Mechanical Translational systems

The model of mechanical translational systems can obtain by using three basic elements mass, spring and dashpot. When a force is applied to a translational mechanical system, it is opposed by opposing forces due to mass, friction and elasticity of the system. The force acting on a mechanical body is governed by Newton's second law of motion. For translational systems it states that the sum of forces acting on a body is zero.

Force balance equations of idealized elements:

Consider an ideal mass element shown in fig. which has negligible friction and elasticity. Let a force be applied on it. The mass will offer an opposing force which is proportional to acceleration of a body.

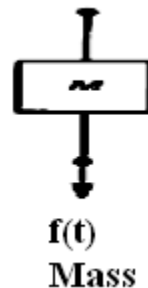

Let f = applied force

f_m = opposing force due to mass

Here $f_m \propto M \frac{d^2 x}{dt^2}$

By Newton's second law, $f = f_m = M \frac{d^2 x}{dt^2}$

Consider an ideal frictional element dash-pot shown in fig. which has negligible mass and elasticity. Let a force be applied on it. The dashpot will offer an opposing force which is proportional to velocity of the body.

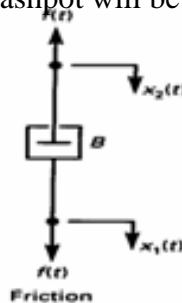

Let f = applied force

f_b = opposing force due to friction

Here, $f_b \propto B \frac{dx}{dt}$

By Newton's second law, $f = f_b = M \frac{dx}{dt}$

Consider an ideal elastic element spring is shown in fig. This has negligible mass and friction.

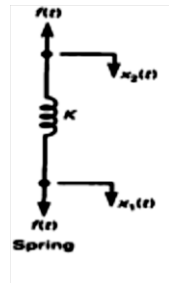

Let f = applied force

f_k = opposing force due to elasticity

Here, $f_k \propto x$

By Newton's second law, $f = f_k = x$

Mechanical Rotational Systems:

The model of rotational mechanical systems can be obtained by using three elements, moment of inertia [J] of mass, dash pot with rotational frictional coefficient [B] and torsional spring with stiffness [k].

When a torque is applied to a rotational mechanical system, it is opposed by opposing torques due to moment of inertia, friction and elasticity of the system. The torque acting on rotational mechanical bodies is governed by Newton's second law of motion for rotational systems.

Torque balance equations of idealized elements

Consider an ideal mass element shown in fig. which has negligible friction and elasticity. The opposing torque due to moment of inertia is proportional to the angular acceleration.

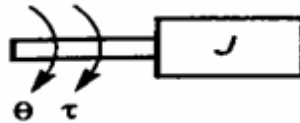

Let T = applied torque

T_j = opposing torque due to moment of inertia of the body

Here $T_j = \alpha J d^2 \theta / dt^2$

By Newton's law

$T = T_j = J d^2 \theta / dt^2$

Consider an ideal frictional element dash pot shown in fig. which has negligible moment of inertia and elasticity. Let a torque be applied on it. The dash pot will offer an opposing torque is proportional to angular velocity of the body.

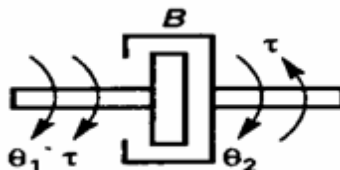

Let T = applied torque

T_b = opposing torque due to friction

Here $T_b = \alpha B d / dt (\theta_1 - \theta_2)$

By Newton's law

$T = T_b = B d / dt (\theta_1 - \theta_2)$

. Consider an ideal elastic element, torsional spring as shown in fig. which has negligible moment of inertia and friction. Let a torque be applied on it. The torsional spring will offer an opposing torque which is proportional to angular displacement of the body



Let T = applied torque

T_k = opposing torque due to friction

Here $T_k \propto K (\theta_1 - \theta_2)$

By Newton's law

$T = T_k = K (\theta_1 - \theta_2)$

Modeling of electrical system

- Electrical circuits involving resistors, capacitors and inductors are considered. The behaviour of such systems is governed by Ohm's law and Kirchhoff's laws
- Resistor: Consider a resistance of ' R ' Ω carrying current ' i ' Amps as shown in Fig (a), then the voltage drop across it is $v = R I$

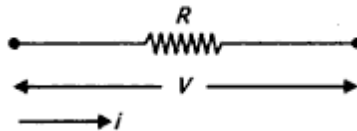

- Inductor: Consider an inductor — L ' H carrying current ' i ' Amps as shown in Fig (a), then the voltage drop across it can be written as $v = L di/dt$

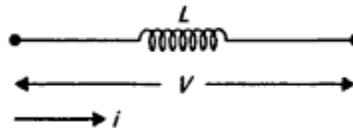

- Capacitor: Consider a capacitor ' C ' F carrying current ' i ' Amps as shown in Fig (a), then the voltage drop across it can be written as $v = (1/C) \int i dt$

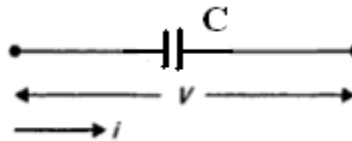

Steps for modeling of electrical system

- Apply Kirchhoff's voltage law or Kirchhoff's current law to form the differential equations describing electrical circuits comprising of resistors, capacitors, and inductors.
- Form Transfer Functions from the describing differential equations.
- Then simulate the model.

Example

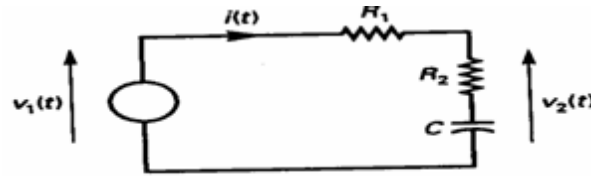

$$R_1 i(t) + R_2 i(t) + 1/C \int i(t) dt = V_1(t)$$

$$R_2 i(t) + 1/C \int i(t) dt = V_2(t)$$

Electrical systems

LRC circuit. Applying Kirchoff's voltage law to the system shown. We obtain the following equation;

Resistance circuit

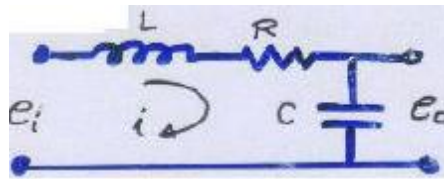

$$L(di/dt) + Ri + 1/C \int i(t) dt = e_i \dots\dots\dots (1)$$

$$1/C \int i(t) dt = e_o \dots\dots\dots (2)$$

Equation (1) & (2) give a mathematical model of the circuit. Taking the L.T. of equations (1)&(2), assuming zero initial conditions, we obtain

$$LsI(s) + RI(s) + \frac{1}{Cs} I(s) = E_i(s)$$

$$\frac{1}{Cs} I(s) = E_o(s)$$

the transfer function
$$\frac{E_o(s)}{E_i(s)} = \frac{1}{LCs^2 + RCs + 1}$$

Armature-Controlled dc motors

The dc motors have separately excited fields. They are either armature-controlled with fixed field or field-controlled with fixed armature current. For example, dc motors used in instruments employ a fixed permanent-magnet field, and the controlled signal is applied to the armature terminals.

Consider the armature-controlled dc motor shown in the following figure.

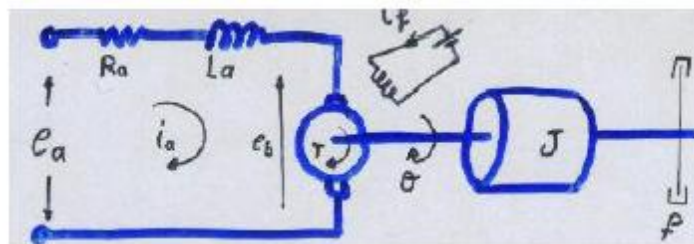

Ra = armature-winding resistance, ohms

La = armature-winding inductance, henrys

ia = armature-winding current, amperes

if = field current, amperes

ea = applied armature voltage, volt

eb = back emf, volts

θ = angular displacement of the motor shaft, radians

T = torque delivered by the motor, Newton*meter

J = equivalent moment of inertia of the motor and load referred to the motor shaft kg.m²

f = equivalent viscous-friction coefficient of the motor and load referred to the motor shaft.

Newton*m/rad/s

T = k1 ia ψ where ψ is the air gap flux, ψ = kf if , k1 is constant

For the constant flux

$$e_b = k_b \frac{d\theta}{dt}$$

Where Kb is a back emf constant ----- (1)

The differential equation for the armature circuit

$$L_a \frac{di_a}{dt} + R_a i_a + e_b = e_a \dots\dots\dots(2)$$

The armature current produces the torque which is applied to the inertia and friction; hence

$$J \frac{d^2\theta}{dt^2} + f \frac{d\theta}{dt} = T = K i_a \dots\dots\dots(3)$$

Assuming that all initial conditions are condition are zero/and taking the L.T. of equations (1), (2) & (3), we obtain

$$K_p s \theta(s) = E_b(s)$$

$$(L_a s + R_a) I_a(s) + E_b(s) = E_a(s) (Js^2 + fs)$$

$$\theta(s) = T(s) = K I_a(s)$$

The T.F can be obtained is

$$\frac{\theta(s)}{E_a(s)} = \frac{K}{s(L_a J s^2 + (L_a f + R_a J)s + R_a f + K K_b)}$$

Analogous Systems

Let us consider a mechanical (both translational and rotational) and electrical system as shown in the fig.

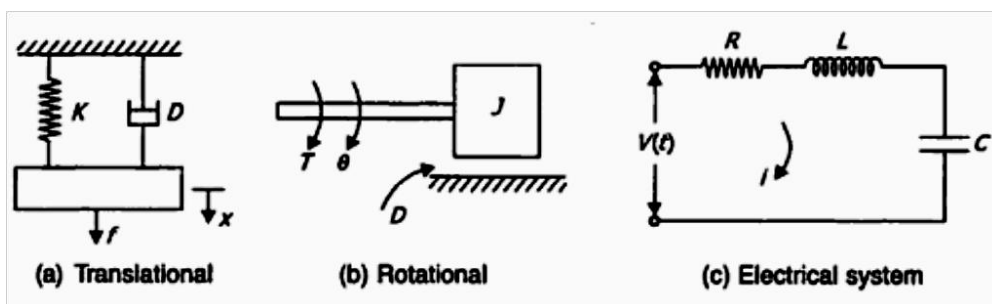

From the fig (a)

$$\text{We get } M \frac{d^2 x}{dt^2} + D \frac{dx}{dt} + Kx = f$$

From the fig (b)

$$\text{We get } M \frac{d^2 \theta}{dt^2} + D \frac{d\theta}{dt} + K\theta = T$$

From the fig (c)

$$\text{We get } L \frac{d^2 q}{dt^2} + R \frac{dq}{dt} + (1/C)q = V(t)$$

Where $q = \int i dt$

They are two methods to get analogous system. These are (i) force- voltage (f-v) analogy and (ii) force-current (f-c) analogy

Translational	Electrical	Rotational
Force (f)	Voltage (v)	Torque (T)
Mass (M)	Inductance (L)	Inertia (J)
Damper (D)	Resistance (R)	Damper (D)
Spring (K)	Elastance $\left(\frac{1}{C}\right)$	Spring (K)
Displacement (x)	Charge (q)	Displacement (θ)
Velocity (u)	Current (i)	Velocity (ω)

Force –Voltage Analogy

Force – Current Analog

Translational	Electrical	Rotational
Force (f)	Current (i)	Torque (T)
Mass (M)	Capacitance (C)	Inertia (J)
Spring (K)	Reciprocal of Inductance $\left(\frac{1}{L}\right)$	Damper (D)
Damper (D)	Conductance $\left(\frac{1}{K}\right)$	Spring (K)
Displacement (x)	Flux Linkage (ψ)	Displacement (θ)
Velocity $\left(u = \frac{dx}{dt}\right)$	Voltage (v) = $\frac{d\psi}{dt}$	Velocity $\left(\omega = \frac{d\theta}{dt}\right)$

Problem

1. Find the system equation for system shown in the fig. And also determine f-v and f-i analogies

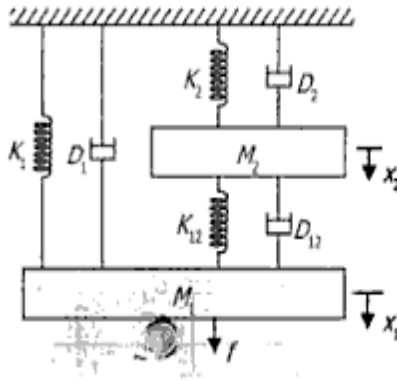

For free body diagram M1

$$f = M_1 \frac{d^2 x_1}{dt^2} + D_1 \frac{dx_1}{dt} + K_1 x_1 + D_{12} \frac{d}{dt} (x_1 - x_2) + K_{12} (x_1 - x_2) \quad (1)$$

For free body diagram M2

$$K_{12} (x_1 - x_2) + D_{12} \frac{d}{dt} (x_1 - x_2) = M_2 \frac{d^2 x_2}{dt^2} + D_2 \frac{dx_2}{dt} + K_2 x_2 \quad (2)$$

Force –voltage analogy

$$f \rightarrow v, M \rightarrow L, D \rightarrow R, K \rightarrow \frac{1}{C}, x \rightarrow q$$

From eq (1) we get

$$v = L_1 \frac{d^2 q_1}{dt^2} + R_1 \frac{dq_1}{dt} + \frac{1}{C_1} q_1 + R_{12} \frac{d}{dt} (q_1 - q_2) + \frac{1}{C_{12}} (q_1 - q_2)$$

$$v = L_1 \frac{di_1}{dt} + R_1 i_1 + \frac{1}{C_1} \int i_1 dt + R_{12} (i_1 - i_2) + \frac{1}{C_{12}} \int (i_1 - i_2) dt \quad (3)$$

From eq (2) we get

$$\frac{1}{C_{12}} (q_1 - q_2) + R_{12} \frac{d}{dt} (q_1 - q_2) = L_2 \frac{d^2 q_2}{dt^2} + R_2 \frac{dq_2}{dt} + \frac{1}{C_2} q_2$$

$$\frac{1}{C_{12}} \int (i_1 - i_2) dt + R_{12} (i_1 - i_2) = L_2 \frac{di_2}{dt} + R_2 i_2 + \frac{1}{C_2} \int i_2 dt \quad \dots(4)$$

From eq (3) and (4) we can draw f-v analogy

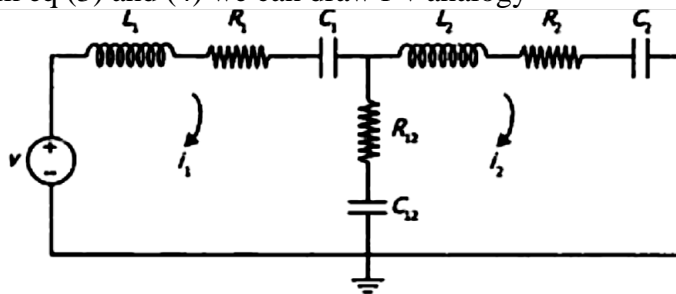

Force-current analogy

$$f \rightarrow i, M \rightarrow C, D \rightarrow \frac{1}{R}, K \rightarrow \frac{1}{L}, x \rightarrow \psi$$

From eq (1) we get

$$i = C_1 \frac{d^2 \psi_1}{dt^2} + \frac{1}{R_1} \frac{d\psi_1}{dt} + \frac{1}{L_1} \psi_1 + \frac{1}{R_{12}} \frac{d(\psi_1 - \psi_2)}{dt} + \frac{1}{L_{12}} (\psi_1 - \psi_2)$$

$$i = C_1 \frac{dv_1}{dt} + \frac{1}{R_1} v_1 + \frac{1}{L_1} \int i_1 dt + \frac{v_1 - v_2}{R_{12}} + \frac{1}{L_{12}} \int (v_1 - v_2) dt \quad \dots\dots\dots(5)$$

From eq (2) we get

$$\frac{1}{L_{12}} (\psi_1 - \psi_2) + \frac{1}{R_{12}} \frac{d(\psi_1 - \psi_2)}{dt} = C_2 \frac{d^2 \psi_2}{dt^2} + \frac{1}{R_2} \frac{d\psi_2}{dt} + \frac{1}{L_2} \psi_2$$

$$\frac{1}{L_{12}} \int (v_1 - v_2) dt + \frac{1}{R_{12}} (v_1 - v_2) = C_2 \frac{dv_2}{dt} + \frac{v_2}{R_2} + \frac{1}{L_2} \int v_2 dt \quad \dots\dots\dots(6)$$

From eq (5) and (6) we can draw force-current analogy

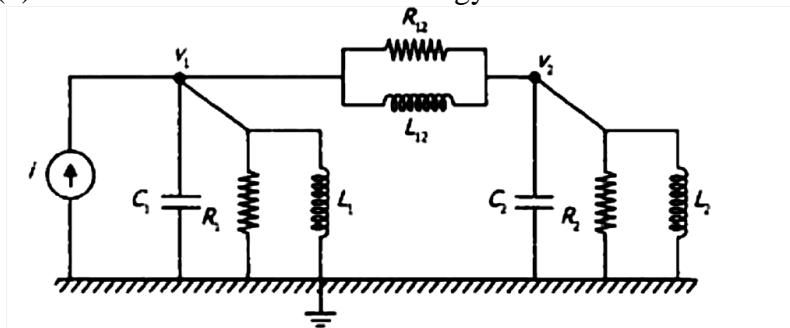

The system can be represented in two forms:

- Block diagram representation
- Signal flow graph

Block diagram

A pictorial representation of the functions performed by each component and of the flow of signals.

Basic elements of a block diagram

- Blocks
- Transfer functions of elements inside the blocks
- Summing points
- Take off points
- Arrow

Block diagram

A control system may consist of a number of components. A block diagram of a system is a pictorial representation of the functions performed by each component and of the flow of signals.

The elements of a block diagram are block, branch point and summing point.

Block

In a block diagram all system variables are linked to each other through functional blocks. The functional block or simply block is a symbol for the mathematical operation on the input signal to the block that produces the output.

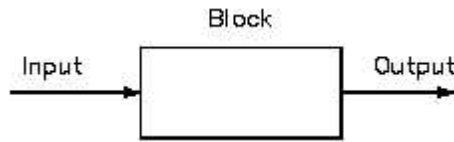

Summing point

Although blocks are used to identify many types of mathematical operations, operations of addition and subtraction are represented by a circle, called a summing point. As shown in Figure a summing point may have one or several inputs. Each input has its own appropriate plus or minus sign.

A summing point has only one output and is equal to the algebraic sum of the inputs.

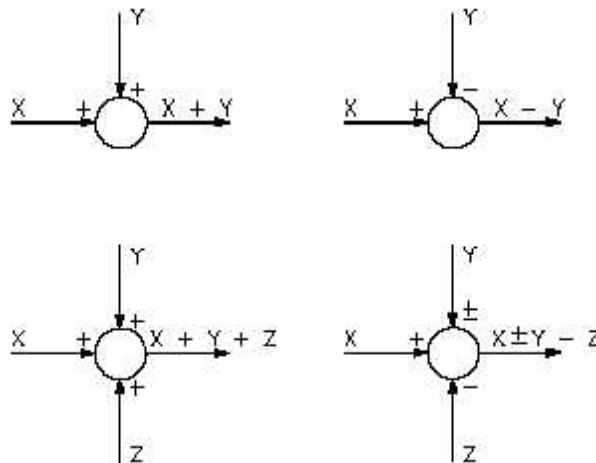

A takeoff point is used to allow a signal to be used by more than one block or summing point.

The transfer function is given inside the block

- The input in this case is $E(s)$
- The output in this case is $C(s)$
- $C(s) = G(s) E(s)$

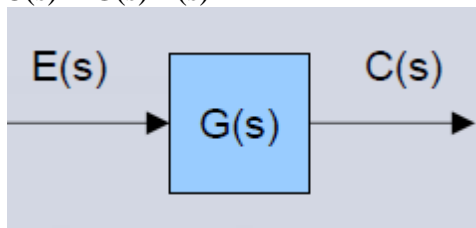

Functional block – each element of the practical system represented by block with its T.F.

Branches – lines showing the connection between the blocks

Arrow – associated with each branch to indicate the direction of flow of signal

Closed loop system

Summing point – comparing the different signals

Take off point – point from which signal is taken for feed back

Advantages of Block Diagram Representation

- Very simple to construct block diagram for a complicated system
- Function of individual element can be visualized
- Individual & Overall performance can be studied
- Overall transfer function can be calculated easily.

Disadvantages of Block Diagram Representation

- No information about the physical construction
- Source of energy is not shown

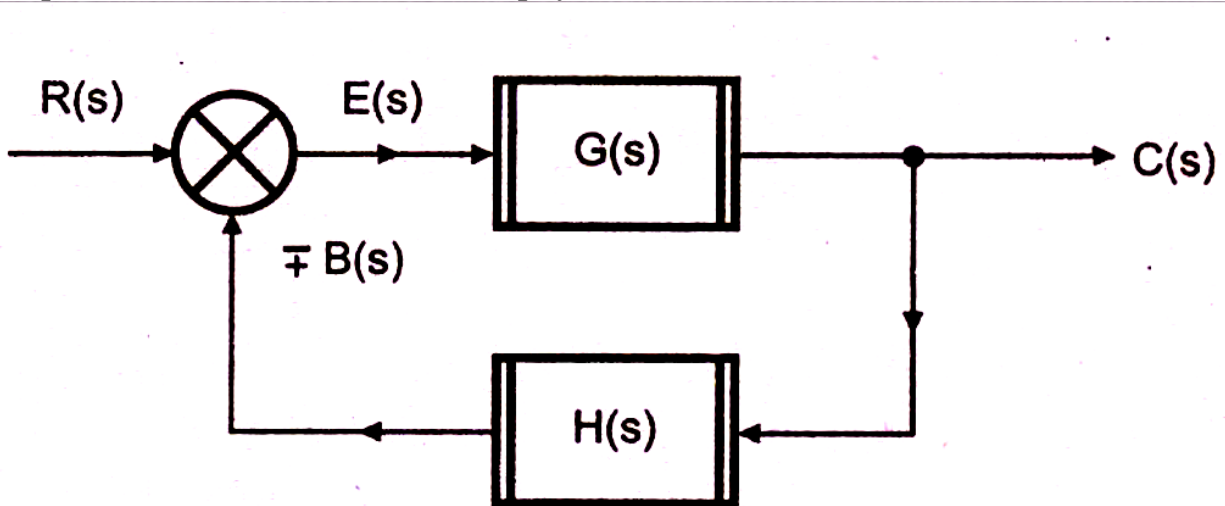
Simple or Canonical form of closed loop system

- $R(s)$ – Laplace of reference input $r(t)$
 $C(s)$ – Laplace of controlled output $c(t)$
 $E(s)$ – Laplace of error signal $e(t)$
 $B(s)$ – Laplace of feed back signal $b(t)$
 $G(s)$ – Forward path transfer function
 $H(s)$ – Feed back path transfer function

Block diagram reduction technique

Because of their simplicity and versatility, block diagrams are often used by control engineers to describe all types of systems. A block diagram can be used simply to represent the composition and interconnection of a system. Also, it can be used, together with transfer functions, to represent the cause-and-effect relationships throughout the system. Transfer Function is defined as the relationship between an input signal and an output signal to a device.

Block diagram rules

Cascaded blocks

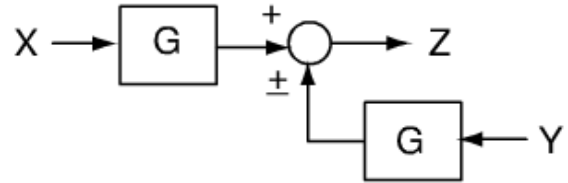
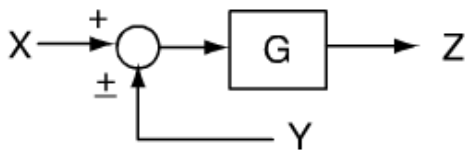

Moving a summer beyond the block

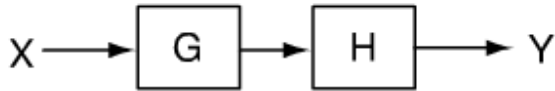

Moving a summer ahead of block

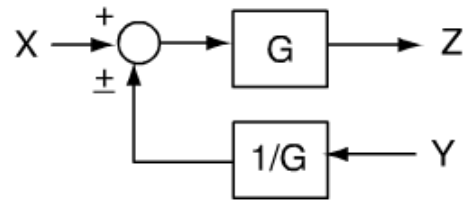
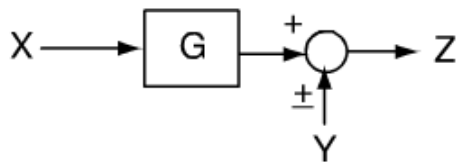

Moving a pick-off ahead of block

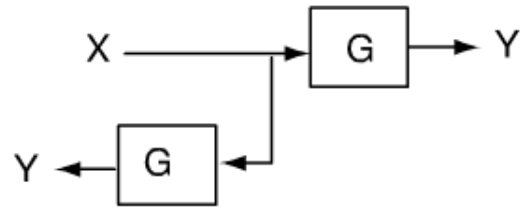
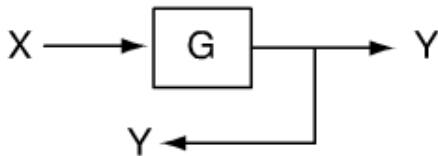

Moving a pick-off behind a block

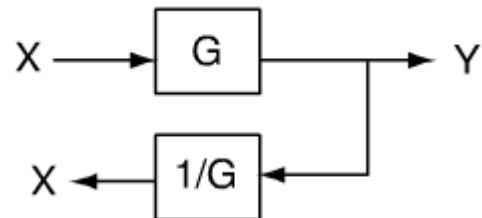
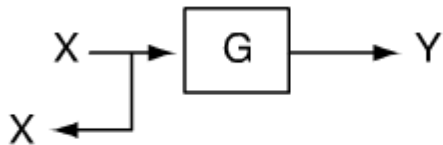

Eliminating a feedback loop

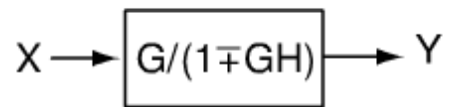
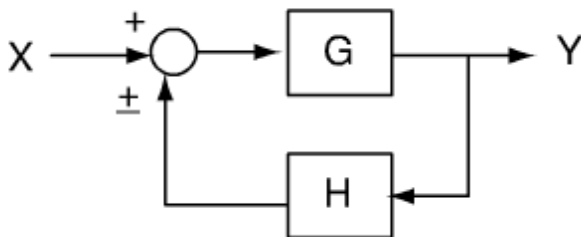

Cascaded Subsystems

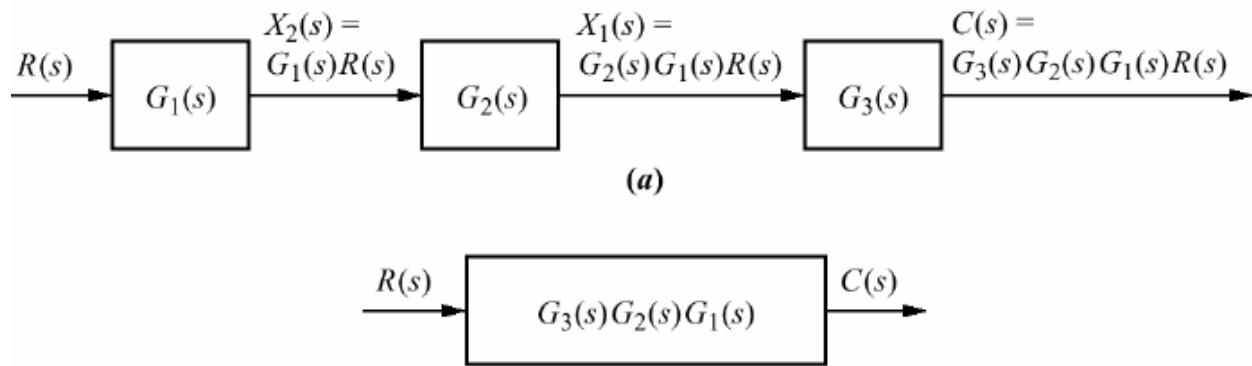

Parallel Subsystems

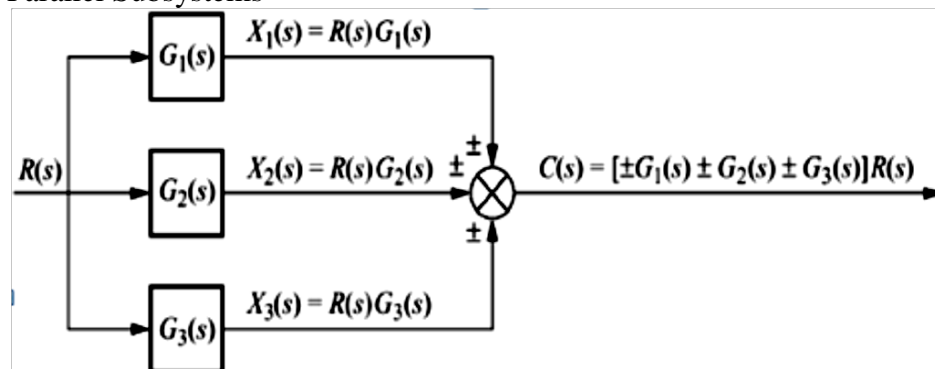

Feedback Control System

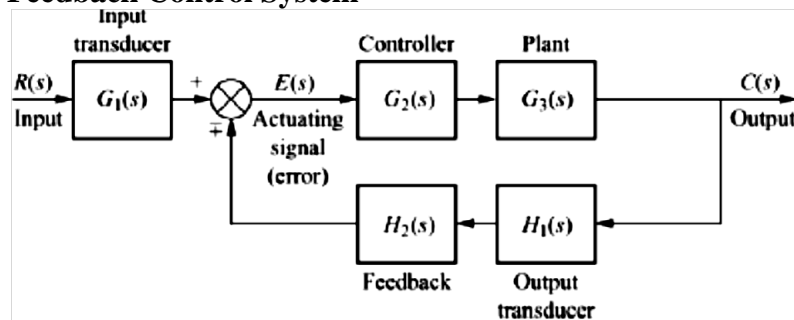

Procedure to solve Block Diagram Reduction Problems

- Step 1: Reduce the blocks connected in series
- Step 2: Reduce the blocks connected in parallel
- Step 3: Reduce the minor feedback loops
- Step 4: Try to shift take off points towards right and Summing point towards left
- Step 5: Repeat steps 1 to 4 till simple form is obtained
- Step 6: Obtain the Transfer Function of Overall System

Problem 1

Obtain the Transfer function of the given block diagram

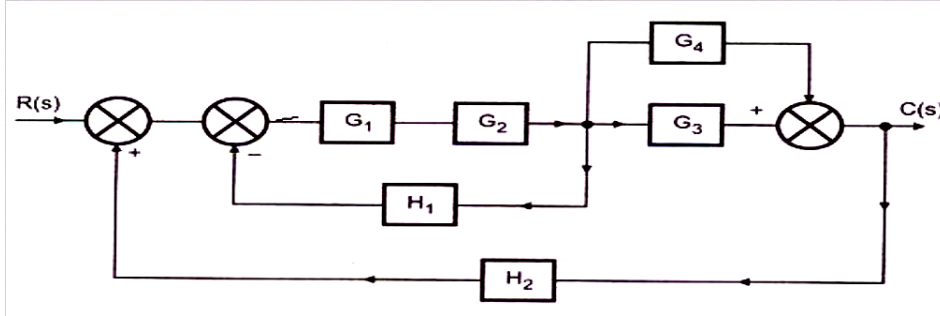

Combine G1, G2 which are in series

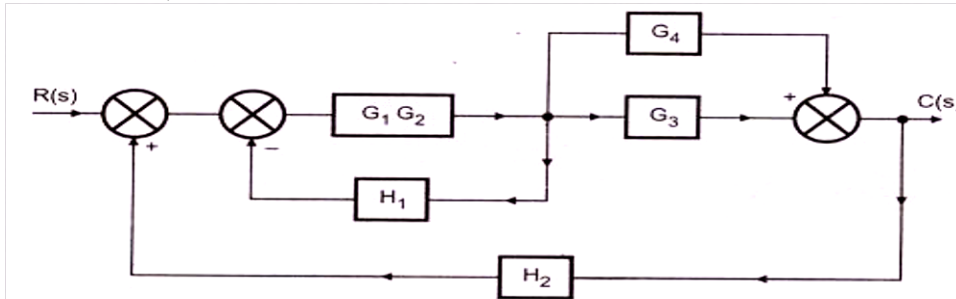

Combine G3, G4 which are in Parallel

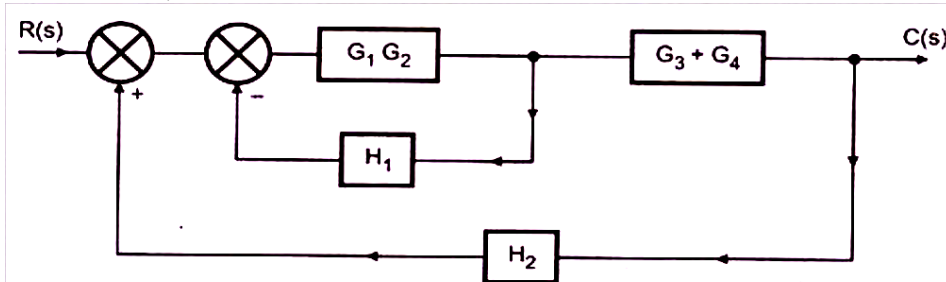

Reduce minor feedback loop of G1, G2 and H1

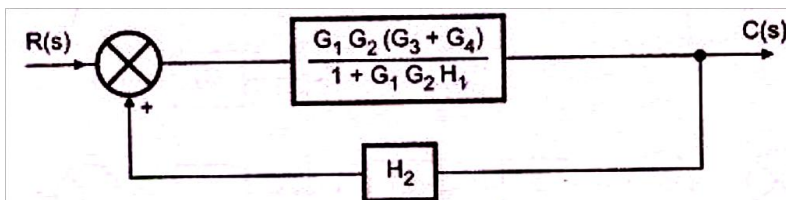
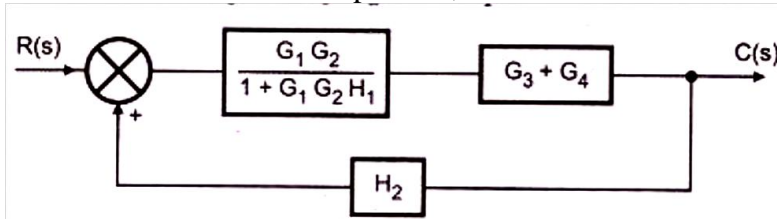

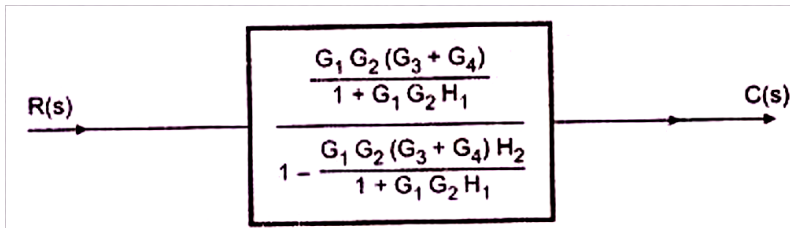

Transfer function

$$\frac{C(s)}{R(s)} = \frac{G_1 G_2 (G_3 + G_4)}{1 + G_1 G_2 H_1 - G_1 G_2 (G_3 + G_4) H_2}$$

2. Obtain the transfer function for the system shown in the fig

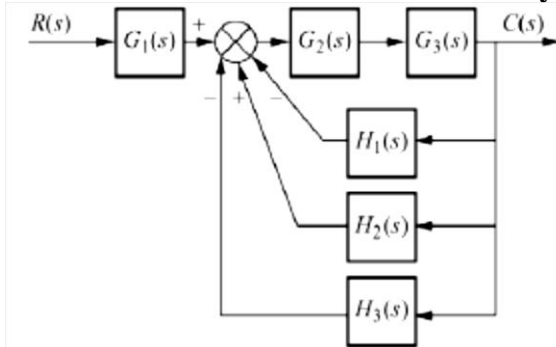

Solution

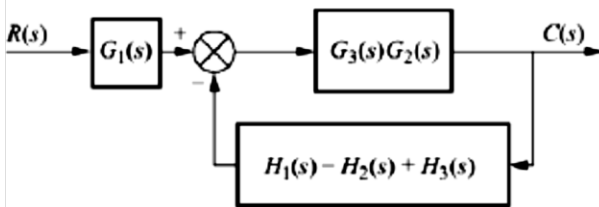

$$\frac{C(s)}{R(s)} = \frac{G_3(s)G_2(s)G_1(s)}{1 + G_3(s)G_2(s)[H_1(s) - H_2(s) + H_3(s)]}$$

3. Obtain the transfer function C/R for the block diagram shown in the fig

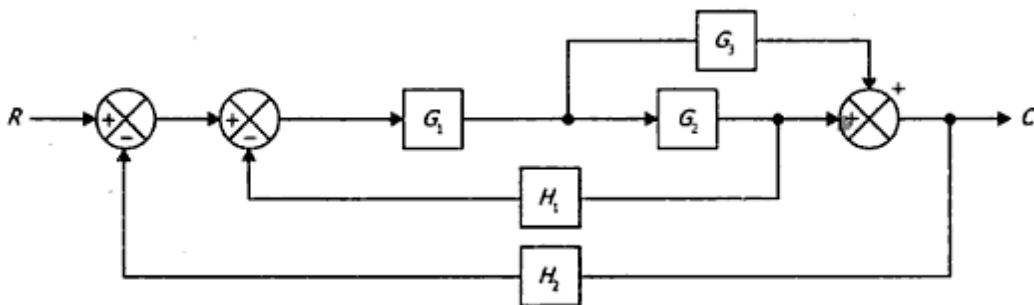

Solution

The take-off point is shifted after the block G_2

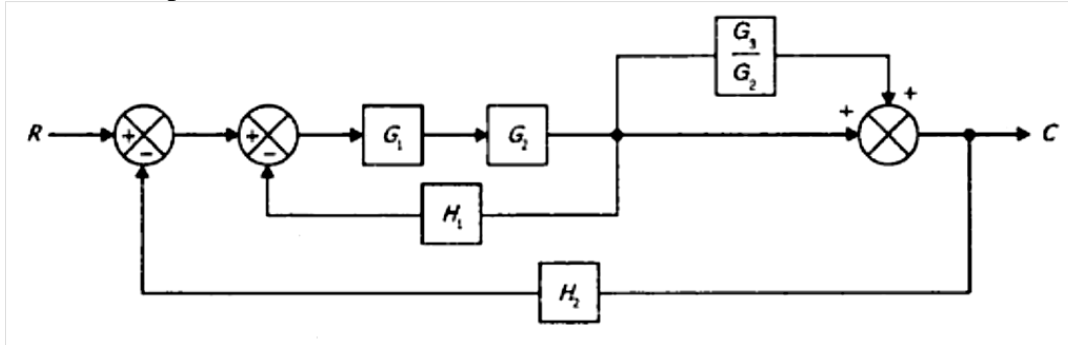

Reducing the cascade block and parallel block

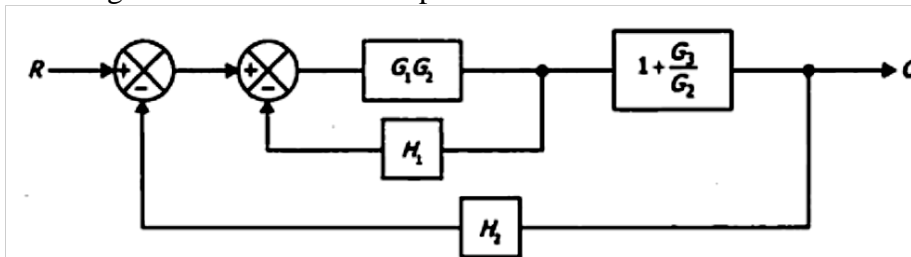

Replacing the internal feedback loop

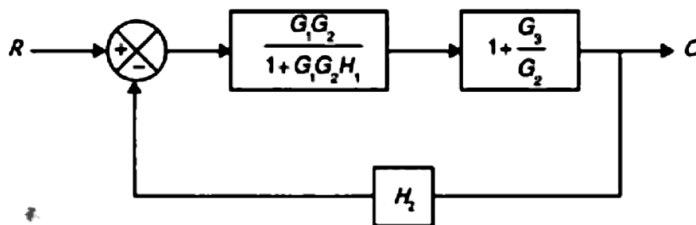

Equivalent block diagram

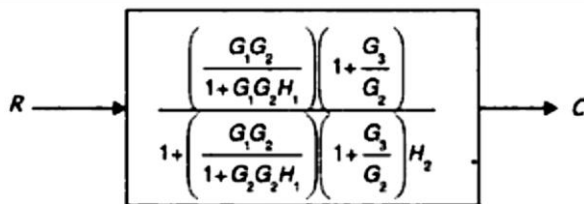

Transfer function

$$\frac{C}{R} = \frac{\frac{G_1 G_2}{1 + G_1 G_2 H_1} \left(1 + \frac{G_3}{G_2} \right)}{1 + \frac{G_1 G_2}{1 + G_1 G_2 H_1} \left(1 + \frac{G_3}{G_2} \right) H_2}$$

$$= \frac{G_1 (G_2 + G_3)}{1 + G_1 G_2 (H_1 + H_2) + G_1 G_3 H_2}$$

Signal Flow Graph Representation

Signal Flow Graph Representation of a system obtained from the equations, which shows the flow of the signal

Signal flow graph

A signal flow graph is a diagram that represents a set of simultaneous linear algebraic equations. By taking Laplace transfer, the time domain differential equations governing a control system can be transferred to a set of algebraic equation in s-domain. A signal-flow graph consists of a network in which nodes are connected by directed branches. It depicts the flow of signals from one point of a system to another and gives the relationships among the signals.

Basic Elements of a Signal flow graph

Node - a point representing a signal or variable.

Branch – unidirectional line segment joining two nodes.

Path – a branch or a continuous sequence of branches that can be traversed from one node to another node.

Loop – a closed path that originates and terminates on the same node and along the path no node is met twice.

Nontouching loops – two loops are said to be nontouching if they do not have a common node.

Mason's gain formula

The relationship between an input variable and an output variable of signal flow graph is given by the net gain between the input and the output nodes is known as overall gain of the system. Mason's gain rule for the determination of the overall system gain is given below.

$$M = \frac{1}{\Delta} \sum_{k=1}^N P_k \Delta_k = \frac{X_{out}}{X_{in}}$$

Where M= gain between Xin and Xout

Xout =output node variable

Xin= input node variable

N = total number of forward paths

Pk= path gain of the kth forward path

$\Delta = 1 - (\text{sum of loop gains of all individual loop}) + (\text{sum of gain product of all possible combinations of two nontouching loops}) - (\text{sum of gain products of all possible combination of three nontouching loops})$

Problem

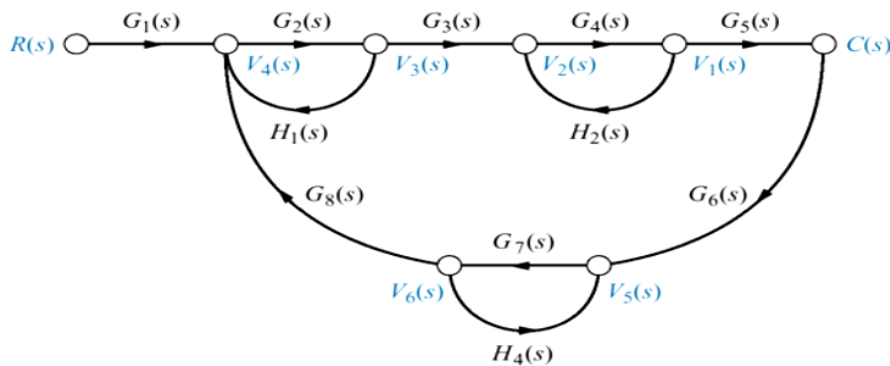

- Forward path gain: $T_1 = G_1(s)G_2(s)G_3(s)G_4(s)G_5(s)$
- Closed loop gain

(1) $G_2(s)H_1(s)$	(2) $G_4(s)H_2(s)$
(3) $G_7(s)H_4(s)$	(4) $G_2(s)G_3(s)G_4(s)G_5(s)G_6(s)G_7(s)G_8(s)$

- Nontouching loops taken two at a time

(5) loop (1) and loop (2): $G_2(s)H_1(s)G_4(s)H_2(s)$

(6) loop (1) and loop (3): $G_2(s)H_1(s)G_7(s)H_4(s)$

(7) loop (2) and loop (3): $G_4(s)H_2(s)G_7(s)H_4(s)$

- Nontouching loops taken three at a time

(8) loops (1), (2), (3): $G_2(s)H_1(s)G_4(s)H_2(s)G_7(s)H_4(s)$

- Now, $\Delta = 1 - \{(1) + (2) + (3) + (4)\} + \{(5) + (6) + (7)\} - (8)$

- Portion of Δ not touching the forward path

$$\Delta_1 = 1 - G_7(s)H_4(s)$$

- Hence,

$$G(s) = \frac{C(s)}{R(s)} = \frac{T_1 \Delta_1}{\Delta}$$

$$= \frac{G_1(s)G_2(s)G_3(s)G_4(s)G_5(s)[1 - G_7(s)H_4(s)]}{\Delta}$$

TIME RESPONSE ANALYSIS

Introduction

- After deriving a mathematical model of a system, the system performance analysis can be done in various methods.
- In analyzing and designing control systems, a basis of comparison of performance of various control systems should be made. This basis may be set up by specifying particular test input signals and by comparing the responses of various systems to these signals.
- The system stability, system accuracy and complete evaluation are always based on the time response analysis and the corresponding results.
- Next important step after a mathematical model of a system is obtained.
- To analyze the system's performance.
- Normally use the standard input signals to identify the characteristics of system's response
 - Step function
 - Ramp function
 - Impulse function
 - Parabolic function
 - Sinusoidal function

Time response analysis

It is an equation or a plot that describes the behavior of a system and contains much information about it with respect to time response specification as overshooting, settling time, peak time, rise time and steady state error. Time response is formed by the transient response and the steady state response.

$$\text{Time response} = \text{Transient response} + \text{Steady state response}$$

Transient time response (Natural response) describes the behavior of the system in its first short time until arrives the steady state value and this response will be our study focus. If the input is step function then the output or the response is called step time response and if the input is ramp, the response is called ramp time response ... etc.

Classification of Time Response

- Transient response
- Steady state response

$$y(t) = y_t(t) + y_{ss}(t)$$

Transient Response

The transient response is defined as the part of the time response that goes to zero as time becomes very large. Thus $y_t(t)$ has the property

$$\lim_{t \rightarrow \infty} y_t(t) = 0$$

The time required to achieve the final value is called transient period. The transient response may be exponential or oscillatory in nature. Output response consists of the sum of forced response (from the input) and natural response (from the nature of the system). The transient response is the change in output response from the beginning of the response to the

final state of the response and the steady state response is the output response as time is approaching infinity (or no more changes at the output).

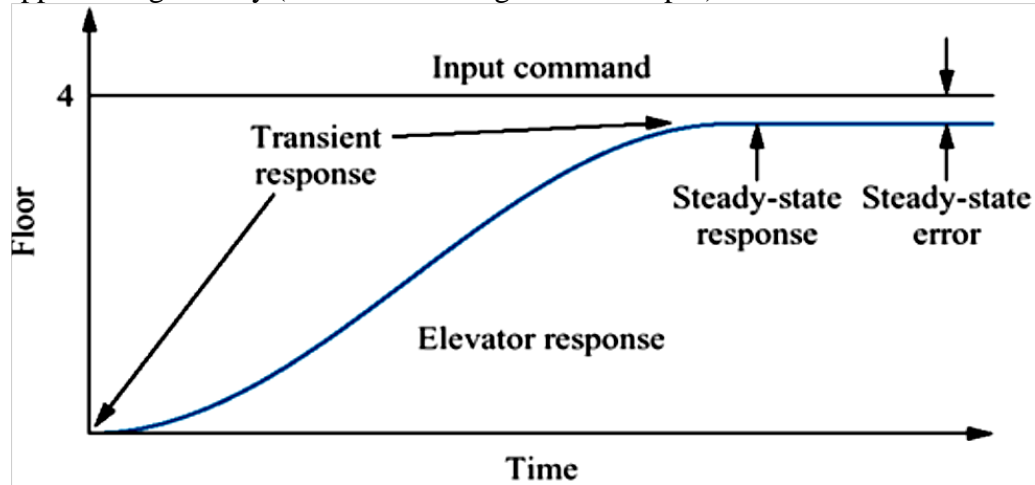

Steady State Response

The steady state response is the part of the total response that remains after the transient has died out. For a position control system, the steady state response when compared to with the desired reference position gives an indication of the final accuracy of the system. If the steady state response of the output does not agree with the desired reference exactly, the system is said to have steady state error.

Typical Input Signals

- Impulse Signal
- Step Signal
- Ramp Signal
- Parabolic Signal

Input	Function	Description	Sketch	Use
Impulse	$\delta(t)$	$\delta(t) = \infty$ for $0^- < t < 0^+$ $= 0$ elsewhere $\int_{0^-}^{0^+} \delta(t) dt = 1$		Transient response Modeling
Step	$u(t)$	$u(t) = 1$ for $t > 0$ $= 0$ for $t < 0$		Transient response Steady-state error
Ramp	$tu(t)$	$tu(t) = t$ for $t \geq 0$ $= 0$ elsewhere		Steady-state error
Parabola	$\frac{1}{2}t^2u(t)$	$\frac{1}{2}t^2u(t) = \frac{1}{2}t^2$ for $t \geq 0$ $= 0$ elsewhere		Steady-state error
Sinusoid	$\sin \omega t$			Transient response Modeling Steady-state error

Time Response Analysis & Design

Two types of inputs can be applied to a control system.

Command Input or Reference Input $y_r(t)$.

Disturbance Input $w(t)$ (External disturbances $w(t)$ are typically uncontrolled variations in the load on a control system).

In systems controlling mechanical motions, load disturbances may represent forces.

In voltage regulating systems, variations in electrical load area major source of disturbances.

Test Signals

Input	$r(t)$	$R(s)$
Step Input	A	A/s
Ramp Input	At	A/s ²
Parabolic Input	At ² / 2	A/s ³
Impulse Input	$\delta(t)$	1

Transfer Function

- One of the types of Modeling a system
- Using first principle, differential equation is obtained
- Laplace Transform is applied to the equation assuming zero initial conditions
- Ratio of LT (output) to LT (input) is expressed as a ratio of polynomial in s in the transfer function.

Order of a system

- The Order of a system is given by the order of the differential equation governing the system
- Alternatively, order can be obtained from the transfer function
- In the transfer function, the maximum power of s in the denominator polynomial gives the order of the system.

Dynamic Order of Systems

- Order of the system is the order of the differential equation that governs the dynamic behaviour
- Working interpretation: Number of the dynamic elements / capacitances or holdup elements between a
- manipulated variable and a controlled variable
- Higher order system responses are usually very difficult to resolve from one another
- The response generally becomes sluggish as the order increases.

System Response

First-order system time response

- ❖ Transient
- ❖ Steady-state

Second-order system time response

- ❖ Transient
- ❖ Steady-state

First Order System

$$Y(s)/R(s) = K/(1 + sT) = K/(1 + sT)$$

Step Response of First Order System

Evolution of the transient response is determined by the pole of the transfer function at $s = -1/t$ where t is the time constant

Also, the step response can be found:

Impulse response	$K / (1+sT)$	Exponential
Step response	$(K/S) - (K / (S+(1/T)))$	Step, exponential
Ramp response	$(K/S^2) - (KT / S) - (KT / (S+1/T))$	Ramp, step, exponential

Second-order systems

LTI second-order system

$$G(s) = \frac{C(s)}{R(s)} = \frac{\omega_n^2}{s^2 + 2\zeta\omega_n s + \omega_n^2}$$

$$(s^2 + 2\zeta\omega_n s + \omega_n^2) C(s) = \omega_n^2 R(s)$$

$$c(t) + 2\zeta\omega_n c(t) + \omega_n^2 c(t) = \omega_n^2 r(t)$$

Second-Order Systems

System	Pole-zero Plot	Response
<p>(a) $R(s) = \frac{1}{s} \rightarrow \frac{G(s)}{s^2 + as + b} \rightarrow C(s)$</p> <p style="text-align: center;">General</p>		
<p>(b) $R(s) = \frac{1}{s} \rightarrow \frac{G(s)}{s^2 + 9s + 9} \rightarrow C(s)$</p> <p style="text-align: center;">Overdamped</p>		<p>$c(t) = 1 + 0.171e^{-7.854t} - 1.171e^{-1.146t}$</p>
<p>(c) $R(s) = \frac{1}{s} \rightarrow \frac{G(s)}{s^2 + 2s + 9} \rightarrow C(s)$</p> <p style="text-align: center;">Underdamped</p>		<p>$c(t) = 1 - e^{-t}(\cos\sqrt{8}t + \frac{\sqrt{8}}{8}\sin\sqrt{8}t)$ $= 1 - 1.06e^{-t}\cos(\sqrt{8}t - 19.47^\circ)$</p>
<p>(d) $R(s) = \frac{1}{s} \rightarrow \frac{G(s)}{s^2 + 9} \rightarrow C(s)$</p> <p style="text-align: center;">Undamped</p>		<p>$c(t) = 1 - \cos 3t$</p>
<p>(e) $R(s) = \frac{1}{s} \rightarrow \frac{G(s)}{s^2 + 6s + 9} \rightarrow C(s)$</p> <p style="text-align: center;">Critically damped</p>		<p>$c(t) = 1 - 3te^{-3t} - e^{-3t}$</p>

Second order system responses

Overdamped response:

Poles: Two real at

$$-\sigma_1 - \sigma_2$$

Natural response: Two exponentials with time constants equal to the reciprocal of the pole location

$$C(t) = k_1 e^{-\sigma_1 t} + k_2 e^{-\sigma_2 t}$$

Poles: Two complex at

Underdamped response:

$$-\sigma_1 \pm jW_d$$

Natural response: Damped sinusoid with an exponential envelope whose time constant is equal to the reciprocal of the pole's real part, the damped frequency of oscillation, is equal to the imaginary part of the poles

Undamped Response:

Poles: Two imaginary at

$$\pm jW_1$$

Natural response: Undamped sinusoid with radian frequency equal to the imaginary part of the poles

$$C(t) = A \cos(w_1 t - \phi)$$

Critically damped responses:

Poles: Two real at

Natural response: One term is an exponential whose time constant is equal to the reciprocal of the pole location. Another term product of time and an exponential with time constant equal to the reciprocal of the pole location.

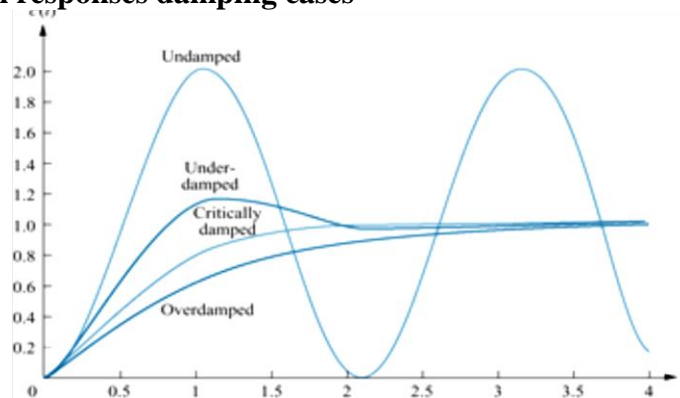
Second order system responses damping cases

Second- order step response
Complex poles

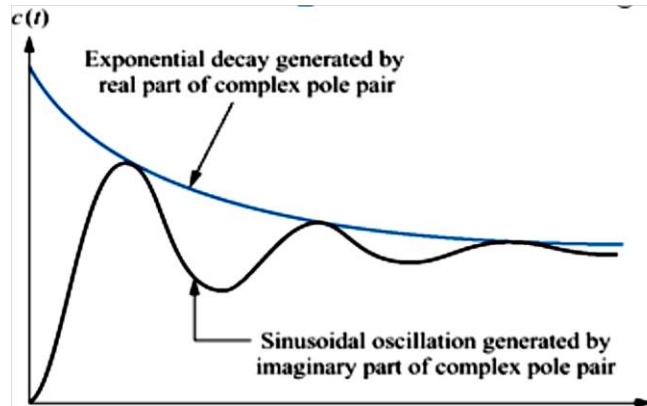

Steady State Error

Consider a unity feedback system
Transfer function between $e(t)$ and $r(t)$

Type of system	Error constants			Steady state error e_s		
	K_p	K_v	K_a	Unit step input	Unit ramp input	Unit parabolic input
0	K	0	0	$1/(1+K)$	∞	∞
1	∞	K	0	0	$1/K$	∞
2	∞	∞	K	0	0	$1/K$
3	∞	∞	∞	0	0	0

Output Feedback Control Systems

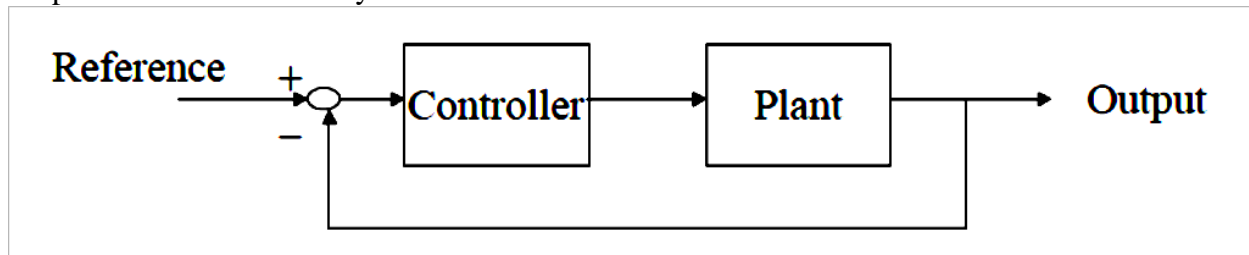

Feedback only the output signal
 – Easy access
 – Obtainable in practice

PID Controllers

Proportional controllers
 – pure gain or attenuation

Integral controllers
– integrate error

Derivative controllers
– differentiate error

Proportional Controller

$$U = K_p e$$

- Controller input is error (reference output)
- Controller output is control signal
- P controller involves only a proportional gain (or attenuation)

Integral Controller

- Integral of error with a constant gain
- Increase system type by 1
- Infinity steady-state gain
- Eliminate steady-state error for a unit step input

Integral Controller

$$\frac{Y(s)}{R(s)} = \frac{G_p(s)}{1 + G_p(s)}$$

$$Y(s) = E(s)G_p(s)$$

$$E(s) = \frac{R(s)}{1 + G_p(s)}$$

$$e_{ss} = \lim_{t \rightarrow \infty} e(t) = \lim_{s \rightarrow 0} sE(s) = \lim_{s \rightarrow 0} \frac{sR(s)}{1 + G_p(s)} = \lim_{s \rightarrow 0} \frac{1}{1 + G_p(s)} = \frac{1}{1 + \infty} = 0$$

Derivative Control

$$u = K_d \frac{de}{dt}$$

- Differentiation of error with a constant gain
- Reduce overshoot and oscillation
- Do not affect steady-state response
- Sensitive to noise

Controller Structure

- Single controller
- P controller, I controller, D controller
- Combination of controllers
- PI controller, PD controller
- PID controller

Controller Performance

- P controller
- PI controller
- PD Controller
- PID Controller

Design of PID Controllers

- Based on the knowledge of P, I and D
- – trial and error
- – manual tuning
- – simulation

Design of PID Controllers

- Time response measurements are particularly simple.
- A step input to a system is simply a suddenly applied input - often just a constant voltage applied through a switch.
- The system output is usually a voltage, or a voltage output from a transducer measuring the output.
- A voltage output can usually be captured in a file using a C program or a Visual Basic program.
- You can use responses in the time domain to help you determine the transfer function of a system.
- First we will examine a simple situation. Here is the step response of a system. This is an example of really "clean" data, better than you might have from measurements. The input to the system is a step of height 0.4. The goal is to determine the transfer function of the system.

Impulse Response of A First Order System

- The impulse response of a system is an important response. The impulse response is the response to a unit impulse.
- The unit impulse has a Laplace transform of unity (1). That gives the unit impulse a unique stature. If a system has a unit impulse input, the output transform is $G(s)$, where $G(s)$ is the transfer function of the system. The unit impulse response is therefore the inverse transform of $G(s)$, i.e. $g(t)$, the time function you get by inverse transforming $G(s)$. If you haven't begun to study Laplace transforms yet, you can just file these last statements away until you begin to learn about Laplace transforms. Still there is an important fact buried in all of this.

- Knowing that the impulse response is the inverse transform of the transfer function of a system can be useful in identifying systems (getting system parameters from measured responses).

In this section we will examine the shapes/forms of several impulse responses. We will start with simple first order systems, and give you links to modules that discuss other, higher order responses.

A general first order system satisfies a differential equation with this general form

If the input, $u(t)$, is a unit impulse, then for a short instant around $t = 0$ the input is infinite. Let us assume that the state, $x(t)$, is initially zero, i.e. $x(0) = 0$. We will integrate both sides of the differential equation from a small time, ϵ , before $t = 0$, to a small time, after $t = 0$. We are just taking advantage of one of the properties of the unit impulse.

The right hand side of the equation is just Gdc since the impulse is assumed to be a unit impulse - one with unit area. Thus, we have:

We can also note that $x(0) = 0$, so the second integral on the right hand side is zero. In other words, what the impulse does is it produces a calculable change in the state, $x(t)$, and this change occurs in a negligibly short time (the duration of the impulse) after $t = 0$. That leads us to a simple strategy for getting the impulse response. Calculate the new initial condition after the impulse passes. Solve the differential equation - with zero input - starting from the newly calculated initial condition.

STABILITY ANALYSIS

Stability

A system is stable if any bounded input produces a bounded output for all bounded initial conditions.



Basic concept of stability

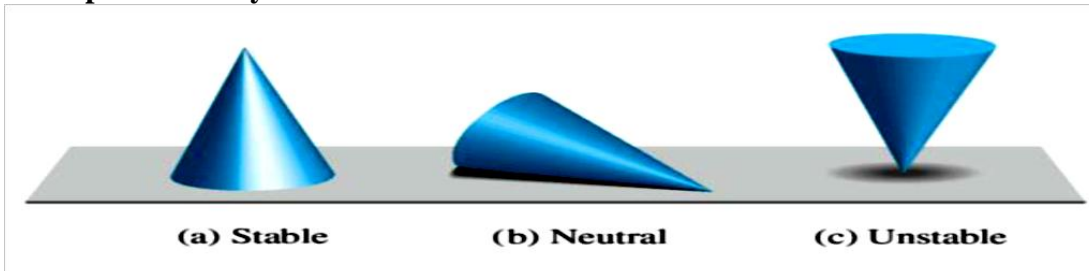

Stability of the system and roots of characteristic equations

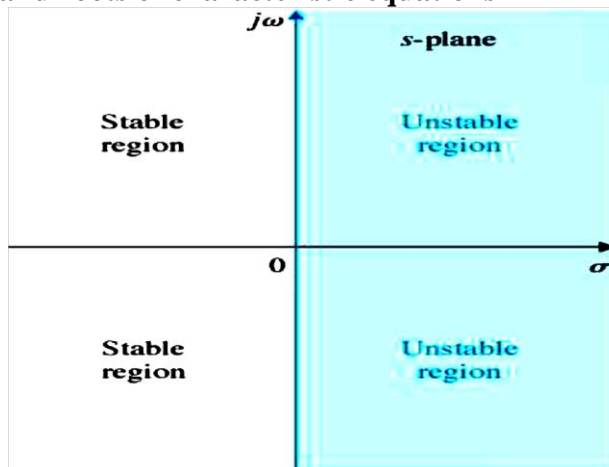

Characteristic Equation

Consider an nth-order system whose the characteristic equation (which is also the denominator of the transfer function) is

$$a(S) = S^n + a_1 S^{n-1} + a_2 S^{n-2} + \dots + a_{n-1} S^1 + a_0 S^0$$

Routh Hurwitz Criterion

Goal: Determining whether the system is stable or unstable from a characteristic equation in polynomial form without actually solving for the roots Routh's stability criterion is useful for determining the ranges of coefficients of polynomials for stability, especially when the coefficients are in symbolic (non numerical) form.

To find K mar & ω

A necessary condition for Routh's Stability

- A necessary condition for stability of the system is that all of the roots of its characteristic equation have negative real parts, which in turn requires that all the coefficients be positive.
- A necessary (but not sufficient) condition for stability is that all the coefficients of the polynomial characteristic equation are positive & none of the co-efficient vanishes.
- Routh's formulation requires the computation of a triangular array that is a function of the coefficients of the polynomial characteristic equation.
- A system is stable if and only if all the elements of the first column of the Routh array are positive

Method for determining the Routh array

Consider the characteristic equation

$$a(S) = 1X S^n + a_1 S^{n-1} + a_2 S^{n-2} + \dots + a_{n-1} S^1 + a_0 S^0$$

Routh array method

Then add subsequent rows to complete the Routh array

Compute elements for the 3rd row:

$$b_1 = -\frac{1 \times a_3 - a_2 a_1}{a_1},$$

$$b_2 = -\frac{1 \times a_5 - a_4 a_1}{a_1},$$

$$b_3 = -\frac{1 \times a_7 - a_6 a_1}{a_1}$$

...

Given the characteristic equation,

$$a(s) = s^6 + 4s^5 + 3s^4 + 2s^3 + s^2 + 4s + 4$$

Is the system described by this characteristic equation stable?

Answer:

- All the coefficients are positive and nonzero
- Therefore, the system satisfies the necessary condition for stability
- We should determine whether any of the coefficients of the first column of the Routh array are negative.

$$\begin{array}{l}
 s^6 : \quad 1 \quad 3 \quad 1 \quad 4 \\
 s^5 : \quad 4 \quad 2 \quad 4 \quad 0 \\
 s^4 : \quad 5/2 \quad 0 \quad 4 \\
 s^3 : \quad 2 \quad -12/5 \quad 0 \\
 s^2 : \quad ? \quad ? \\
 s^1 : \quad ? \quad ? \\
 s^0 : \quad ?
 \end{array}$$

$S^6:$	1	3	1	4
$S^5:$	4	2	4	0
$S^4:$	$5/2$	0	4	
$S^3:$	2	$-12/5$	0	
$S^2:$	3	4		
$S^1:$	$-76/15$	0		
$S^0:$	4			

The elements of the 1st column are not all positive. Then the system is unstable

Special cases of Routh's criteria:

Case 1: All the elements of a row in a RA are zero

- Form Auxiliary equation by using the co-efficient of the row which is just above the row of zeros.
- Find derivative of the A.E.
- Replace the row of zeros by the co-efficient of $dA(s)/ds$
- Complete the array in terms of these coefficients.
- analyze for any sign change, if so, unstable
- no sign change, find the nature of roots of AE
- non-repeated imaginary roots - marginally stable
- repeated imaginary roots – unstable

Case 2:

- First element of any of the rows of RA is
- Zero and the same remaining row contains atleast one non-zero element
- Substitute a small positive no. ϵ in place of zero and complete the array.
- Examine the sign change by taking $\lim_{\epsilon \rightarrow 0} \epsilon = 0$

Root Locus Technique

- Introduced by W. R. Evans in 1948
- Graphical method, in which movement of poles in the s-plane is sketched when some parameter is varied The path taken by the roots of the characteristic equation when open loop gain K is varied from 0 to ∞ are called root loci
- Direct Root Locus = $0 < k < \infty$
- Inverse Root Locus = $-\infty < k < 0$

Root Locus Analysis:

- The roots of the closed-loop characteristic equation define the system characteristic responses
- Their location in the complex s-plane lead to prediction of the characteristics of the time domain responses in terms of:
 - damping ratio ζ ,
 - natural frequency, ω_n
 - damping constant σ , first-order modes
- Consider how these roots change as the loop gain is varied from 0 to ∞

Basics of Root Locus:

- Symmetrical about real axis
- RL branch starts from OL poles and terminates at OL zeroes
- No. of RL branches = No. of poles of OLTF
- Centroid is common intersection point of all the asymptotes on the real axis
- Asymptotes are straight lines which are parallel to RL going to ∞ and meet the RL at ∞
- No. of asymptotes = No. of branches going to ∞
- At Break Away point , the RL breaks from real axis to enter into the complex plane
- At BI point, the RL enters the real axis from the complex plane

Constructing Root Locus:

- Locate the OL poles & zeros in the plot
- Find the branches on the real axis
- Find angle of asymptotes & centroid
- $\Phi_a = \pm 180^\circ(2q+1) / (n-m)$
- $\zeta_a = (\Sigma \text{poles} - \Sigma \text{zeroes}) / (n-m)$
- Find BA and BI points
- Find Angle Of departure (AOD) and Angle Of Arrival (AOA)
- $\text{AOD} = 180^\circ - (\text{sum of angles of vectors to the complex pole from all other poles}) + (\text{Sum of angles of vectors to the complex pole from all zero})$
- $\text{AOA} = 180^\circ - (\text{sum of angles of vectors to the complex zero from all other zeros}) + (\text{sum of angles of vectors to the complex zero from poles})$
- Find the point of intersection of RL with the imaginary axis.

Application of the Root Locus Procedure

Step 1: Write the characteristic equation as

$$1 + F(s) = 0$$

Step 2: Rewrite preceding equation into the form of poles and zeros as follows

$$1 + K \frac{\prod_{j=1}^m (s - z_j)}{\prod_{i=1}^n (s - p_i)} = 0$$

Step 3:

- Locate the poles and zeros with specific symbols, the root locus begins at the open-loop poles and ends at the open loop zeros as K increases from 0 to infinity
- If open-loop system has n-m zeros at infinity, there will be n-m branches of the root locus approaching the n-m zeros at infinity

Step 4:

- The root locus on the real axis lies in a section of the real axis to the left of an odd number of real poles and zeros

Step 5:

- The number of separate loci is equal to the number of open-loop poles

Step 6:

- The root loci must be continuous and symmetrical with respect to the horizontal real axis

Step 7:

- The loci proceed to zeros at infinity along asymptotes centered at centroid and with angles

$$\sigma_a = \frac{\sum_{i=1}^n p_i - \sum_{j=1}^m z_j}{n-m}$$

$$\phi_a = \frac{(2k+1)\pi}{n-m} \quad (k = 0, 1, 2, \dots, n-m-1)$$

Step 8:

- The actual point at which the root locus crosses the imaginary axis is readily evaluated by using Routh's criterion

Step 9:

- Determine the breakaway point d (usually on the real axis)

Step 10:

- Plot the root locus that satisfy the phase criterion

$$\angle P(s) = (2k+1)\pi \quad k = 1, 2, \dots$$

Step 11:

Determine the parameter value K_I at a specific root using the magnitude criterion

$$K_1 = \frac{\prod_{i=1}^n |(s - p_i)|}{\prod_{j=1}^m |(s - z_j)|} \Bigg|_{s=s_1}$$

Nyquist Stability Criteria:

The Routh-Hurwitz criterion is a method for determining whether a linear system is stable or not by examining the locations of the roots of the characteristic equation of the system. In fact, the method determines only if there are roots that lie outside of the left half plane; it does not actually compute the roots. Consider the characteristic equation.

To determine whether this system is stable or not, check the following conditions

$$1 + GH(s) = D(s) = a_n s^n + a_{n-1} s^{n-1} + \dots + a_1 s + a_0 = 0$$

- Two necessary but not sufficient conditions that all the roots have negative real parts are
 - All the polynomial coefficients must have the same sign.
 - All the polynomial coefficients must be nonzero.
- If condition (1) is satisfied, then compute the Routh-Hurwitz array as follows

$$\begin{array}{c|cccc}
 s^n & a_n & a_{n-2} & a_{n-4} & a_{n-6} & \dots \\
 s^{n-1} & a_{n-1} & a_{n-3} & a_{n-5} & a_{n-7} & \dots \\
 s^{n-2} & b_1 & b_2 & b_3 & & \dots \\
 s^{n-3} & c_1 & c_2 & c_3 & & \dots \\
 s^{n-4} & & & \vdots & & \\
 \vdots & & & \vdots & & \\
 s^1 & & & \vdots & & \\
 s^0 & & & \vdots & &
 \end{array}$$

Where the a_i 's are the polynomial coefficients, and the coefficients in the rest of the table are computed using the following pattern

$$b_1 = \frac{-1}{a_{n-1}} \begin{vmatrix} a_n & a_{n-2} \\ a_{n-1} & a_{n-3} \end{vmatrix} = \frac{-1}{a_{n-1}} (a_n a_{n-3} - a_{n-2} a_{n-1})$$

$$b_2 = \frac{-1}{a_{n-1}} \begin{vmatrix} a_n & a_{n-4} \\ a_{n-1} & a_{n-5} \end{vmatrix}$$

$$b_3 = \frac{-1}{a_{n-1}} \begin{vmatrix} a_n & a_{n-6} \\ a_{n-1} & a_{n-7} \end{vmatrix} \dots$$

$$c_1 = \frac{-1}{b_1} \begin{vmatrix} a_{n-1} & a_{n-3} \\ b_1 & b_2 \end{vmatrix}$$

$$c_2 = \frac{-1}{b_1} \begin{vmatrix} a_{n-1} & a_{n-5} \\ b_1 & b_3 \end{vmatrix} \dots$$

3. The necessary condition that all roots have negative real parts is that all the elements of the first column of the array have the same sign. The number of changes of sign equals the number of roots with positive real parts.
4. Special Case 1: The first element of a row is zero, but some other elements in that row are nonzero. In this case, simply replace the zero elements by " ", complete the table development, and then interpret the results assuming that " " is a small number of the same sign as the

element above it. The results must be interpreted in the limit as ϵ to 0.

5. Special Case 2: All the elements of a particular row are zero. In this case, some of the roots of the polynomial are located symmetrically about the origin of the s -plane, e.g., a pair of purely imaginary roots. The zero rows will always occur in a row associated with an odd power of s . The row just above the zero rows holds the coefficients of the auxiliary polynomial. The roots of the auxiliary polynomial are the symmetrically placed roots. Be careful to remember that the coefficients in the array skip powers of s from one coefficient to the next.

Let P = no. of poles of $q(s)$ -plane lying on Right Half of s -plane and encircled by s -plane contour.

Let Z = no. of zeros of $q(s)$ -plane lying on Right Half of s -plane and encircled by s -plane contour.

For the CL system to be stable, the no. of zeros of $q(s)$ which are the CL poles that lie in the right half of s -plane should be zero. That is $Z = 0$, which gives $N = -P$.

Therefore, for a stable system the no. of ACW encirclements of the origin in the $q(s)$ -plane by the contour C_q must be equal to P .

Nyquist modified stability criteria

- We know that $q(s) = 1 + G(s)H(s)$

Therefore $G(s)H(s) = [1 + G(s)H(s)] - 1$

- The contour C_q , which has obtained due to mapping of Nyquist contour from s -plane to $q(s)$ -plane (ie) $[1 + G(s)H(s)]$ -plane, will encircle about the origin.
- The contour C_{GH} , which has obtained due to mapping of Nyquist contour from s -plane to $G(s)H(s)$ -plane, will encircle about the point $(-1 + j0)$.
- Therefore encircling the origin in the $q(s)$ -plane is equivalent to encircling the point $-1 + j0$ in the $G(s)H(s)$ -plane.

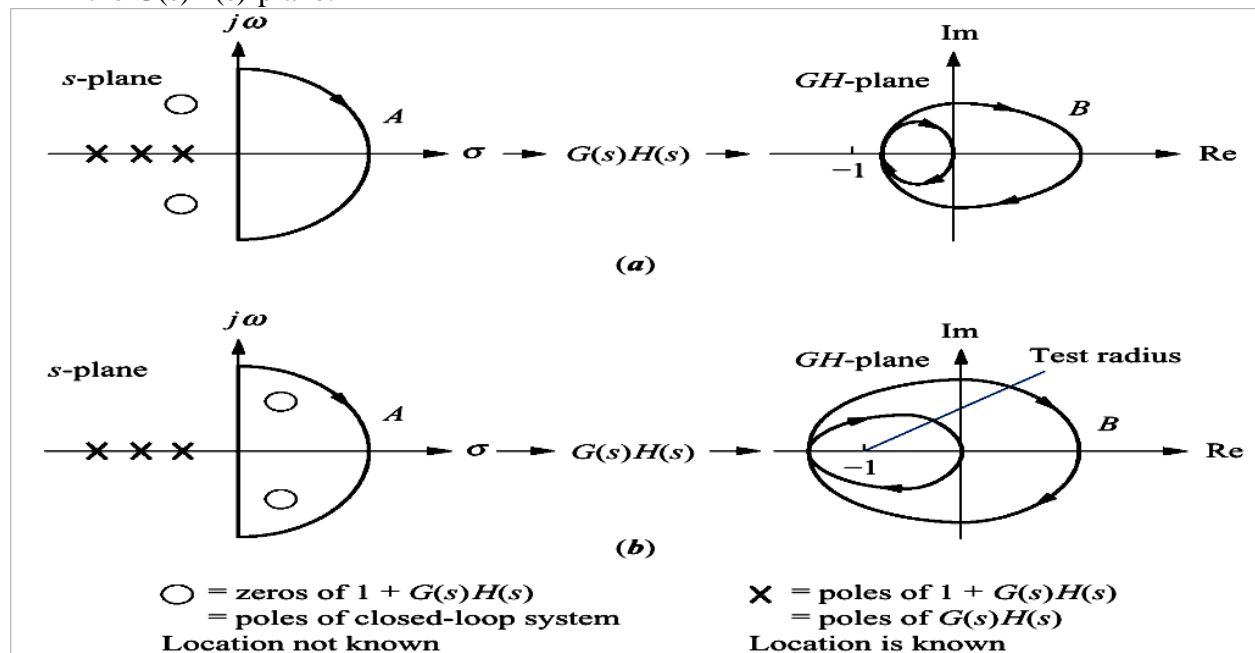

Problem

Sketch the Nyquist stability plot for a feedback system with the following open-loop transfer function

$$G(s)H(s) = \frac{1}{s(s^2 + s + 1)}$$

Solution

For section ab, $s = j\omega$, $\omega : 0 \rightarrow \infty$

$$G(j\omega)H(j\omega) = \frac{1}{j\omega(1 - \omega^2 + j\omega)}$$

(i) $\omega \rightarrow 0 : G(j\omega)H(j\omega) \rightarrow -1 - j\infty$

(ii) $\omega = 1 : G(j\omega)H(j\omega) \rightarrow -1 + j0$

(iii) $\omega \rightarrow \infty : G(j\omega)H(j\omega) \rightarrow 0 \angle -270^\circ$

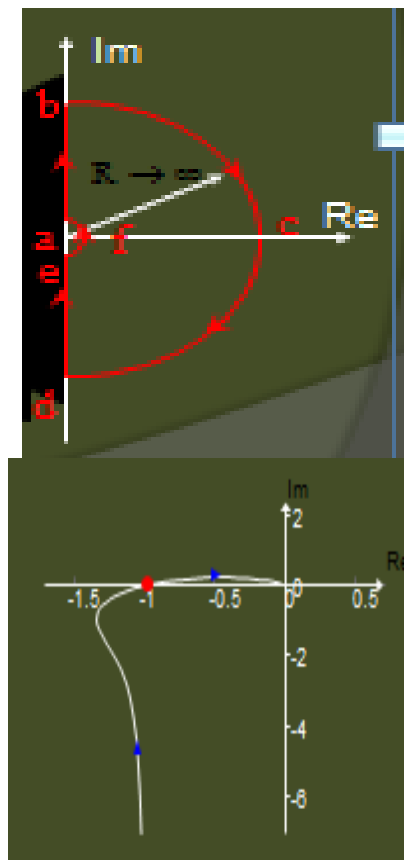

On section bcd, $s = Re^{j\theta} |_{R \rightarrow \infty}$; therefore i.e. section bcd maps onto the origin of the $G(s)H(s)$ -plane

$$|G(s)H(s)| \rightarrow \frac{1}{R^3} \rightarrow 0$$

Section de maps as the complex image of the polar plot as before

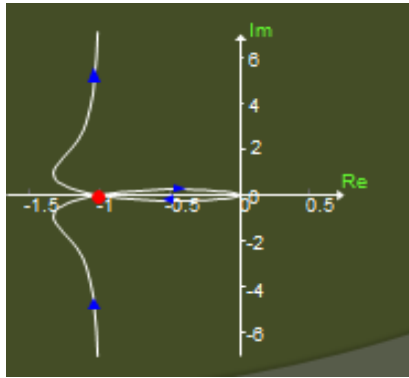

Relative stability

The main disadvantage of a Bode plot is that we have to draw and consider two different curves at a time, namely, magnitude plot and phase plot. Information contained in these two plots can be combined into one named polar plot. The polar plot is for a frequency range of $0 < \omega < \infty$, while the Nyquist plot is in the frequency range of $-\infty < \omega < \infty$. The information on the negative frequency is redundant because the magnitude and real part of $G(j\omega)$ are even functions. In this section, we consider how to evaluate the system performance in terms of relative stability using a Nyquist plot. The open-loop system represented by this plot will become unstable beyond a certain value. As shown in the Nyquist plot of Fig. the intercept of magnitude 'a' on the negative real axis corresponds lost phase shift of -180° and 'a' represents the amount of increase in gain that can be tolerated before closed-loop system tends toward instability. As 'a' approaches $(-1 + j0)$ point the relative stability is reduced; the gain and phase margins are represented as follows in the Nyquist plot.

Gain margin

As system gain is increased by a factor $1/a$, the open loop magnitude of $G(j\omega)H(j\omega)$ will increase by a factor $a(1/a) = 1$ and the system would be driven to instability. Thus, the gain margin is the reciprocal of the gain at the frequency at which the phase angle of the Nyquist plot is -180° . The gain margin, usually measured in dB, is a positive quantity given by

$$GM = -20 \log a \text{ dB}$$

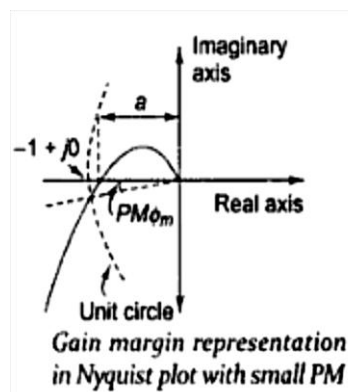

Phase Margin ϕ_m

Importance of the phase margin has already in the content of Bode. Phase margin is defined as the change in open-loop phase shift required at unity gain to make a closed loop system unstable. A closed-loop system will be unstable if the Nyquist plot encircles $-1 + j0$ point. Therefore, the angle required to make this system marginally stable in a closed loop is the phase

margin. In order to measure this angle, we draw a circle with a radius of 1, and find the point of intersection of the Nyquist plot with this circle, and measure the phase shift needed for this point to be at an angle of 180° . It may be appreciated that the system having plot of Fig with larger PM is more stable than the one with plot of Fig.

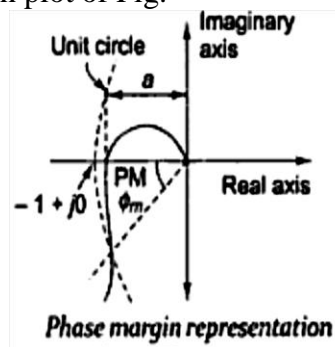

FREQUENCY RESPONSE ANALYSIS

Frequency Response

The frequency response of a system is a frequency dependent function which expresses how a sinusoidal signal of a given frequency on the system input is transferred through the system. Time-varying signals at least periodical signals —which excite systems, as the reference (set point) signal or a disturbance in a control system or measurement signals which are inputs signals to signal filters, can be regarded as consisting of a sum of frequency components. Each frequency component is a sinusoidal signal having certain amplitude and a certain frequency. (The Fourier series expansion or the Fourier transform can be used to express these frequency components quantitatively.) The frequency response expresses how each of these frequency components is transferred through the system. Some components may be amplified, others may be attenuated, and there will be some phase lag through the system.

The frequency response is an important tool for analysis and design of signal filters (as low pass filters and high pass filters), and for analysis, and to some extent, design, of control systems. Both signal filtering and control systems applications are described (briefly) later in this chapter. The definition of the frequency response — which will be given in the next section — applies only to linear models, but this linear model may very well be the local linear model about some operating point of a non-linear model. The frequency response can found experimentally or from a transfer function model. It can be presented graphically or as a mathematical function.

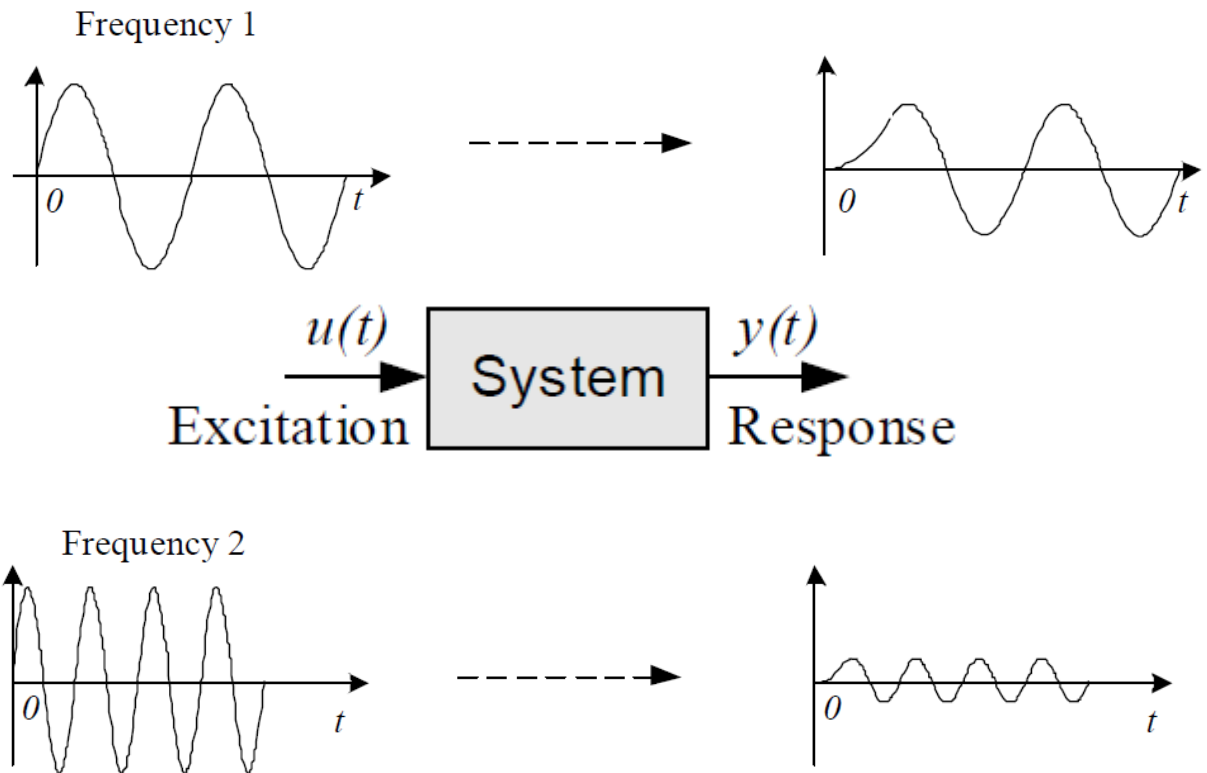

Bode plot

- Plots of the magnitude and phase characteristics are used to fully describe the frequency response
- A **Bode plot** is a (semilog) plot of the transfer function magnitude and phase angle as a function of frequency.

The gain magnitude is many times expressed in terms of decibels (dB)

$$\text{db} = 20 \log 10 A$$

BODE PLOT PROCEDURE:

There are 4 basic forms in an open-loop transfer function $G(j\omega)H(j\omega)$

- Gain Factor K
- $(j\omega)^{\pm p}$ factor: pole and zero at origin
- $(1+j\omega T)^{\pm q}$ factor
- Quadratic factor
 $1+j2\zeta(W/W_n)-(W^2/W_n^2)$

Gain margin and Phase margin**Gain margin:**

The gain margin is the number of dB that is below 0 dB at the phase crossover frequency ($\phi=-180^\circ$). It can also be increased before the closed loop system becomes unstable

Term	Corner Frequency	Slope db /dec	Change in slope
$20/jW$	-----	-20	
$1/(1+4jW)$	$WC_1=1/4 = 0.25$	-20	-20-20=-40
$1/(1+j3w)$	$wc_2=1/3=0.33$	-20	-40-20=-60

Phase margin:

The phase margin is the number of degrees the phase of that is above -180° at the gain crossover frequency

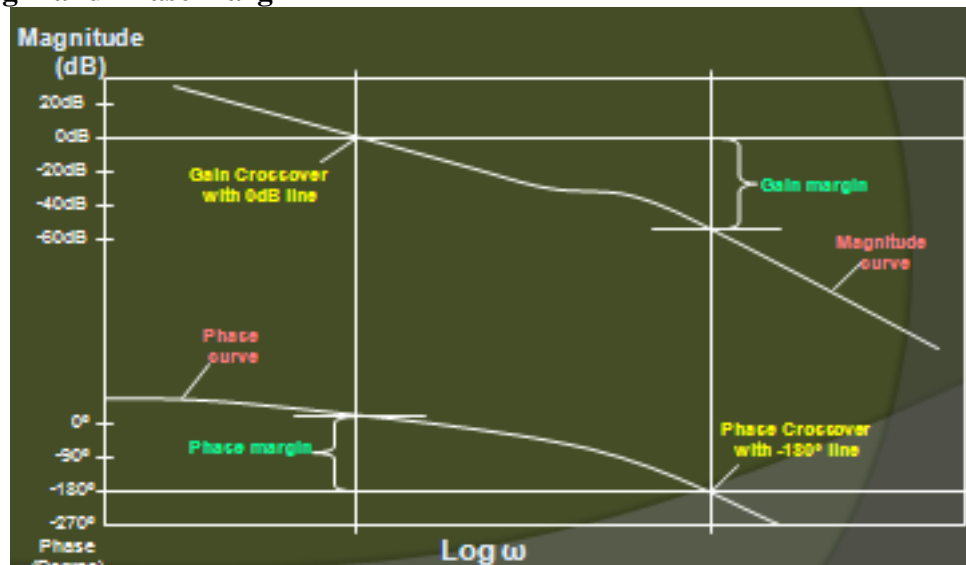
Gain margin and Phase margin

Bode Plot – Example

For the following T.F draw the Bode plot and obtain Gain cross over frequency (ω_{gc}), Phase cross over frequency, Gain Margin and Phase Margin.

$$G(s) = 20 / [s(1+3s)(1+4s)]$$

Solution:

The sinusoidal T.F of $G(s)$ is obtained by replacing s by $j\omega$ in the given T.F

$$G(j\omega) = 20 / [j\omega(1+j3\omega)(1+j4\omega)]$$

Corner frequencies:

$$\omega_{c1} = 1/4 = 0.25 \text{ rad/sec ;}$$

$$\omega_{c2} = 1/3 = 0.33 \text{ rad/sec}$$

Choose a lower corner frequency and a higher Corner frequency

$$\omega_l = 0.025 \text{ rad/sec ;}$$

$$\omega_h = 3.3 \text{ rad/sec}$$

Calculation of Gain (A) (MAGNITUDE PLOT)

$$A @ \omega_l ; A = 20 \log [20 / 0.025] = 58.06 \text{ dB}$$

$$A @ \omega_{c1} ; A = [\text{Slope from } \omega_l \text{ to } \omega_{c1} \times \log (\omega_{c1} / \omega_l) + \text{Gain (A)} @ \omega_l$$

$$= - 20 \log [0.25 / 0.025] + 58.06$$

$$= 38.06 \text{ dB}$$

$$A @ \omega_{c2} ; A = [\text{Slope from } \omega_{c1} \text{ to } \omega_{c2} \times \log (\omega_{c2} / \omega_{c1}) + \text{Gain (A)} @ \omega_{c1}$$

$$= - 40 \log [0.33 / 0.25] + 38$$

$$= 33 \text{ dB}$$

$$A @ \omega_h ; A = [\text{Slope from } \omega_{c2} \text{ to } \omega_h \times \log (\omega_h / \omega_{c2}) + \text{Gain (A)} @ \omega_{c2}$$

$$= - 60 \log [3.3 / 0.33] + 33$$

$$= -27 \text{ dB}$$

Calculation of Phase angle for different values of frequencies [PHASE PLOT]

$$\phi = -90^\circ - \tan^{-1} 3\omega - \tan^{-1} 4\omega$$

When

Frequency in rad / sec	Phase angles in Degree
$\omega=0$	$\phi = -90^\circ$
$\omega = 0.025$	$\phi = -99^\circ$
$\omega = 0.25$	$\phi = -172^\circ$
$\omega = 0.33$	$\phi = -188^\circ$
$\omega = 3.3$	$\phi = -259^\circ$
$\omega = \infty$	$\phi = -270^\circ$

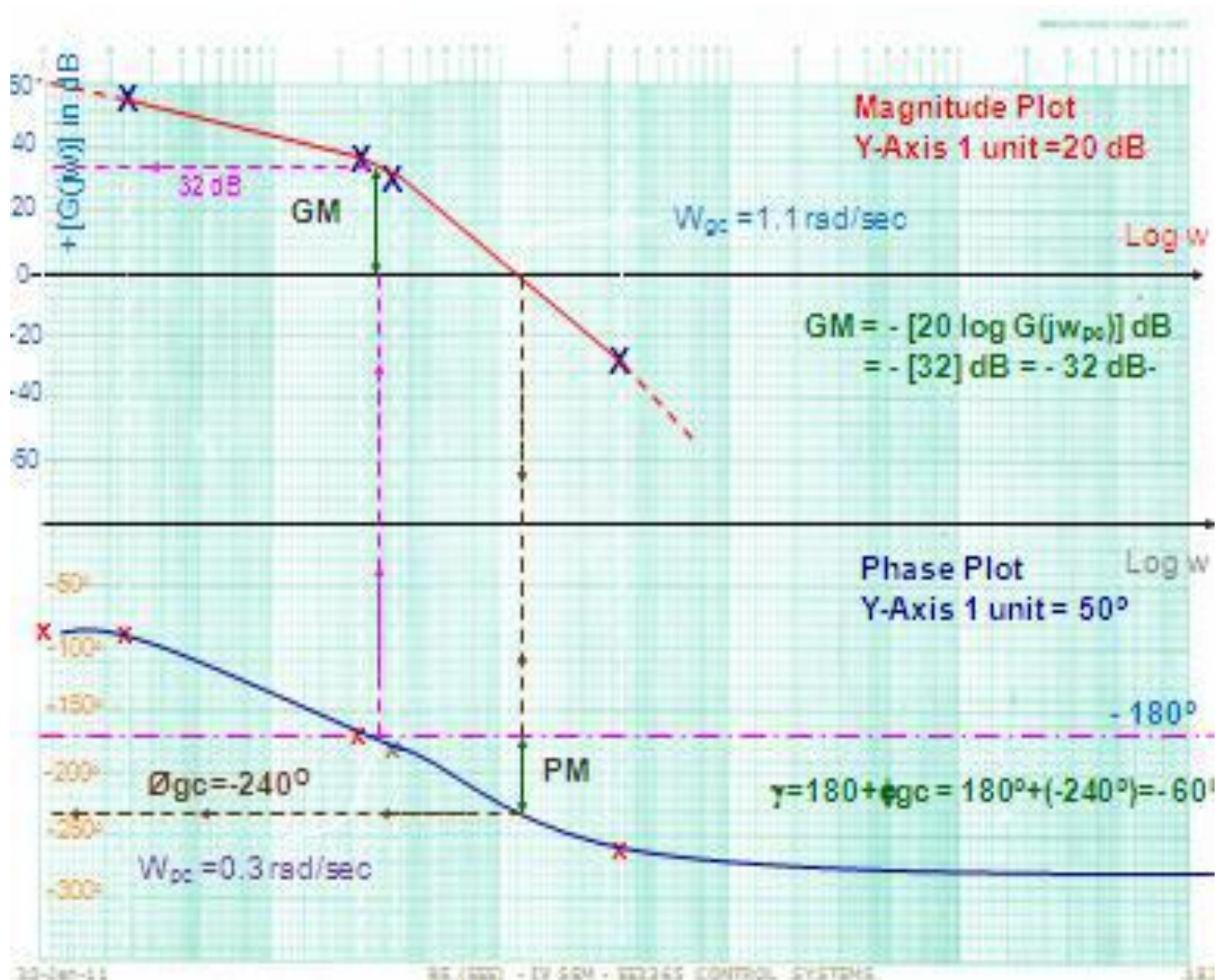

- **Calculations of Gain cross over frequency**

The frequency at which the dB magnitude is Zero
 $\omega_{gc} = 1.1$ rad / sec

- **Calculations of Phase cross over frequency**

The frequency at which the Phase of the system is - 180°
 $\omega_{pc} = 0.3$ rad / sec

- **Gain Margin**

The gain margin in dB is given by the negative of dB magnitude of $G(j\omega)$ at phase cross over frequency

$$GM = - \{ 20 \log [G(j\omega_{pc})] \} = - \{ 32 \} = -32 \text{ dB}$$

- **Phase Margin**

$$\Gamma = 180^\circ + \phi_{gc} = 180^\circ + (-240^\circ) = -60^\circ$$

- **Conclusion**

For this system GM and PM are negative in values. Therefore the system is unstable in nature.

Polar plot

To sketch the polar plot of $G(j\omega)$ for the entire range of frequency ω , i.e., from 0 to infinity, there are four key points that usually need to be known:

- (1) the start of plot where $\omega = 0$,
- (2) the end of plot where $\omega = \infty$,
- (3) where the plot crosses the real axis, i.e., $\text{Im}(G(j\omega)) = 0$, and
- (4) where the plot crosses the imaginary axis, i.e., $\text{Re}(G(j\omega)) = 0$.

BASICS OF POLAR PLOT:

- The polar plot of a sinusoidal transfer function $G(j\omega)$ is a plot of the magnitude of $G(j\omega)$ Vs the phase of $G(j\omega)$ on polar co-ordinates as ω is varied from 0 to ∞ .
(ie) $|G(j\omega)|$ Vs angle $G(j\omega)$ as $\omega \rightarrow 0$ to ∞ .
- Polar graph sheet has concentric circles and radial lines.
- Concentric circles represents the magnitude.
- Radial lines represents the phase angles.
- In polar sheet
+ve phase angle is measured in ACW from 0^0
-ve phase angle is measured in CW from 0^0

PROCEDURE

- Express the given expression of OLTF in $(1+sT)$ form.
- Substitute $s = j\omega$ in the expression for $G(s)H(s)$ and get $G(j\omega)H(j\omega)$.
- Get the expressions for $|G(j\omega)H(j\omega)|$ & angle $G(j\omega)H(j\omega)$.
- Tabulate various values of magnitude and phase angles for different values of ω ranging from 0 to ∞ .
- Usually the choice of frequencies will be the corner frequency and around corner frequencies.
- Choose proper scale for the magnitude circles.
- Fix all the points in the polar graph sheet and join the points by a smooth curve.
- Write the frequency corresponding to each of the point of the plot.

MINIMUM PHASE SYSTEMS:

- Systems with all poles & zeros in the Left half of the s-plane – Minimum Phase Systems.
- For Minimum Phase Systems with only poles
- Type No. determines at what quadrant the polar plot starts.
- Order determines at what quadrant the polar plot ends.
- Type No. \rightarrow No. of poles lying at the origin
- Order \rightarrow Max power of 's' in the denominator polynomial of the transfer function.

GAIN MARGIN

- Gain Margin is defined as “the factor by which the system gain can be increased to drive the system to the verge of instability”.
- For stable systems,

$$\omega_{gc} < \omega_{pc}$$

Magnitude of $G(j\omega)H(j\omega)$ at $\omega = \omega_{pc} < 1$

GM = in positive dB

More positive the GM, more stable is the system.

- For marginally stable systems,

$$\omega_{gc} = \omega_{pc}$$

magnitude of $G(j\omega)H(j\omega)$ at $\omega = \omega_{pc} = 1$

GM = 0 dB

For Unstable systems,

$$\omega_{gc} > \omega_{pc}$$

magnitude of $G(j\omega)H(j\omega)$ at $\omega = \omega_{pc} > 1$

GM = in negative dB

Gain is to be reduced to make the system stable

Note:

- If the gain is high, the GM is low and the system's step response shows high overshoots and long settling time.
- On the contrary, very low gains give high GM and PM, but also causes higher ess, higher values of rise time and settling time and in general give sluggish response.
- Thus we should keep the gain as high as possible to reduce ess and obtain acceptable response speed and yet maintain adequate GM & PM.
- An adequate GM of 2 i.e. (6 dB) and a PM of 30 is generally considered good enough as a thumb rule.

At $\omega = \omega_{pc}$, angle of $G(j\omega)H(j\omega) = -180^\circ$

- Let magnitude of $G(j\omega)H(j\omega)$ at $\omega = \omega_{pc}$ be taken as B
- If the gain of the system is increased by factor $1/B$, then the magnitude of $G(j\omega)H(j\omega)$ at $\omega = \omega_{pc}$ becomes $B(1/B) = 1$ and hence the $G(j\omega)H(j\omega)$ locus pass through $-1+j0$ point driving the system to the verge of instability.
- GM is defined as the reciprocal of the magnitude of the OLTF evaluated at the phase cross over frequency.

$$\text{GM in dB} = 20 \log (1/B) = -20 \log B$$

PHASE MARGIN

Phase Margin is defined as “ the additional phase lag that can be introduced before the system becomes unstable”.

‘A’ be the point of intersection of $G(j\omega)H(j\omega)$ plot and a unit circle centered at the origin.

Draw a line connecting the points ‘O’ & ‘A’ and measure the phase angle between the line OA and

+ve real axis.

This angle is the phase angle of the system at the gain cross over frequency.

Angle of $G(j\omega_{gc})H(j\omega_{gc}) = \phi_{gc}$

If an additional phase lag of ϕ PM is introduced at this frequency, then the phase angle $G(j\omega_{gc})H(j\omega_{gc})$ will become 180° and the point ‘A’ coincides with $(-1+j0)$ driving the system to the verge of instability.

This additional phase lag is known as the Phase Margin.

$$\gamma = 180^\circ + \text{angle of } G(j\omega_{gc})H(j\omega_{gc})$$

$$\gamma = 180^\circ + \phi_{gc}$$

[Since ϕ_{gc} is measured in CW direction, it is taken as negative]

For a stable system, the phase margin is positive.

- A Phase margin close to zero corresponds to highly oscillatory system.

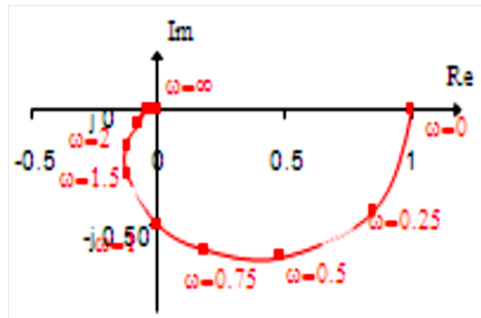

- A polar plot may be constructed from experimental data or from a system transfer function
- If the values of ω are marked along the contour, a polar plot has the same information as a bode plot.
- Usually, the shape of a polar plot is of most interest.

Nyquist Plot:

The Nyquist plot is a polar plot of the function

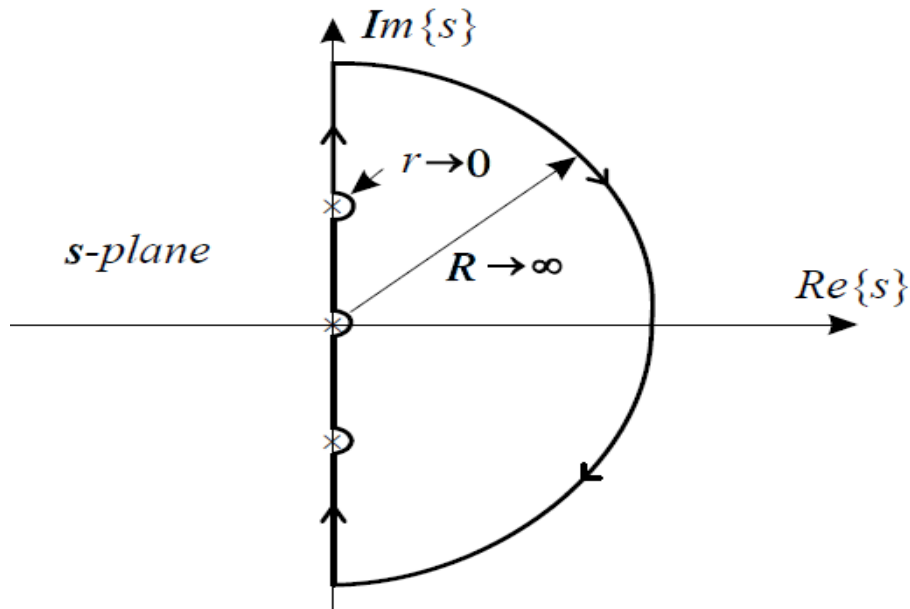

The Nyquist stability criterion relates the location of the roots of the characteristic equation to the open-loop frequency response of the system. In this, the computation of closed-loop poles is not necessary to determine the stability of the system and the stability study can be carried out graphically from the open-loop frequency response. Therefore experimentally determined open-loop frequency response can be used directly for the study of stability. When the feedback path is closed. The Nyquist criterion has the following features that make it an alternative method that is attractive for the analysis and design of control systems. 1. In addition to providing information on absolute and relative.

Nyquist Plot Example

Consider the following transfer function

$$G(s) = \frac{k(s+1)}{s^2(s+4)(s+5)}$$

Change it from “s” domain to “jw” domain:

$$G(j\omega) = \frac{k(j\omega+1)}{(j\omega)^2(j\omega+4)(j\omega+5)}$$

Find the magnitude and phase angle equations:

$$\frac{k(\sqrt{\omega^2+1})}{\omega^2(\sqrt{\omega^2+16})(\sqrt{\omega^2+25})} \angle -180 + \tan^{-1} \omega - \tan^{-1} \left(\frac{\omega}{4}\right) - \tan^{-1} \left(\frac{\omega}{5}\right)$$

Evaluate magnitude and phase angle at $\omega = 0+$ and $\omega = +\infty$

At $\omega = 0+$

$$|G(j\omega)| \angle G(j\omega) \Rightarrow \infty \angle -180 + \epsilon$$

At $\omega = \infty$

$$|G(j\omega)| \angle G(j\omega) \Rightarrow \infty \angle -180 + \epsilon$$

At $\omega = \infty$

$$|G(j\omega)| \angle G(j\omega) \Rightarrow 0 \angle -270$$

Draw the nyquist plot:

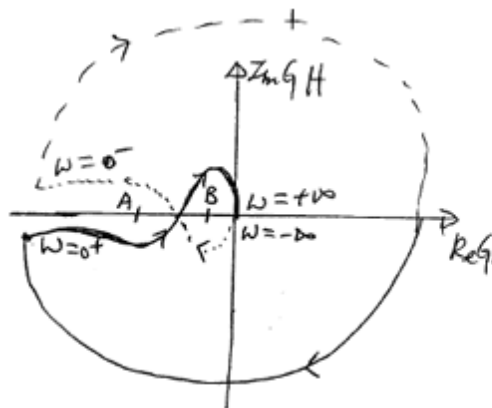

Frequency domain specifications

- The resonant peak M_r is the maximum value of $jM(j\omega)j$.
- The resonant frequency ω_r is the frequency at which the peak resonance M_r occurs.
- The bandwidth BW is the frequency at which $|G(j\omega)|$ drops to 70.7% (3 dB) of its zero-frequency value.

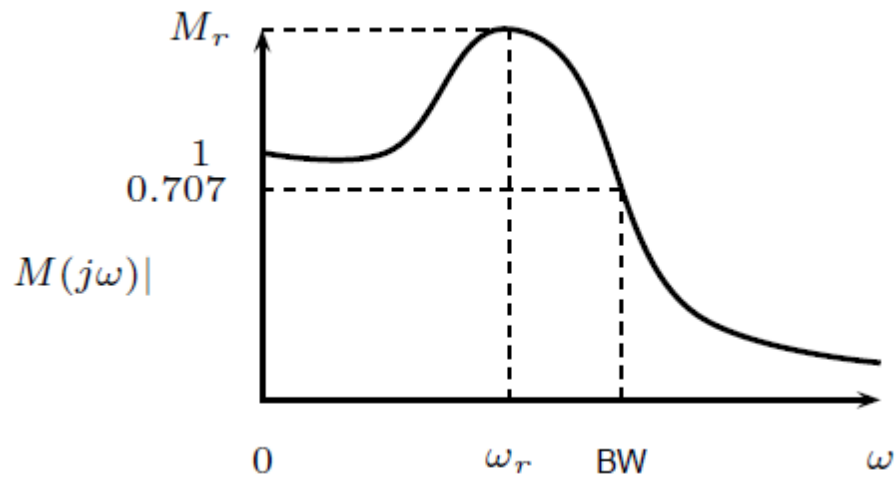

- M_r indicates the relative stability of a stable closed loop system.
- A large M_r corresponds to larger maximum overshoot of the step response.
- Desirable value: 1.1 to 1.5
- BW gives an indication of the transient response properties of a control system.
- A large bandwidth corresponds to a faster rise time. BW and rise time t_r are inversely proportional.
- BW also indicates the noise-filtering characteristics and robustness of the system.
- Increasing ω_n increases BW.
- BW and M_r are proportional to each other.

Constant M and N circles

Consider a candidate design of a loop transfer function $L(j\omega)$ shown on the RHS.

$$T(j\omega) = \frac{L(j\omega)}{1+L(j\omega)}$$

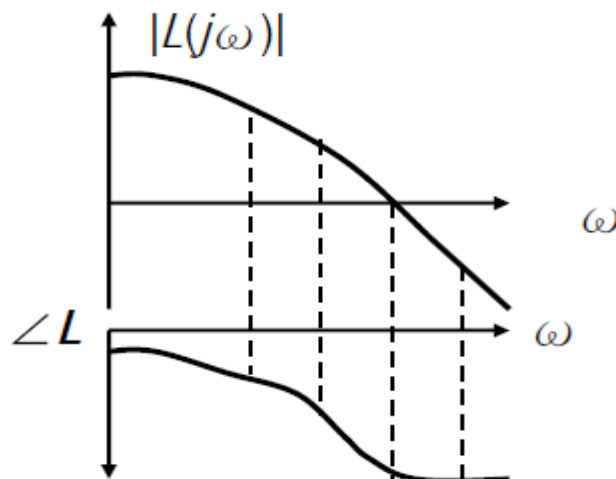

Evaluate $T(j\omega)$ from $L(j\omega)$ in the manner of frequency point by frequency point. Alternatively, the Bode plot of $L(j\omega)$ can also be shown on the complex plane to form its Nyquist plot.

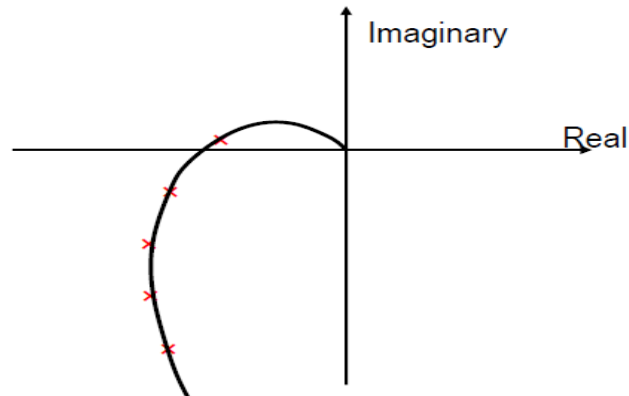

M circles (constant magnitude of T)

In order to precisely evaluate $|T(j\omega)|$ from the Nyquist plot of $L(j\omega)$, a tool called M circle is developed as followed.

Let $L(j\omega) = X + jY$, where X is the real and Y the imaginary part. Then

$$|T(j\omega)| = M = \frac{|X(j\omega) + jY(j\omega)|}{|1 + X(j\omega) + jY(j\omega)|}$$

$$M(j\omega)^2 = \frac{X(j\omega)^2 + Y(j\omega)^2}{(1 + X(j\omega))^2 + Y(j\omega)^2}$$

Rearranging the above equations, it gives

$$X^2(1-M^2) - 2M^2X - M^2 + (1-M^2)Y^2 = 0$$

That is, all (X, Y) pair corresponding to a constant value of M for a circle on the complex plane. Therefore, we have the following (constant) M circles on the complex plane as shown below.

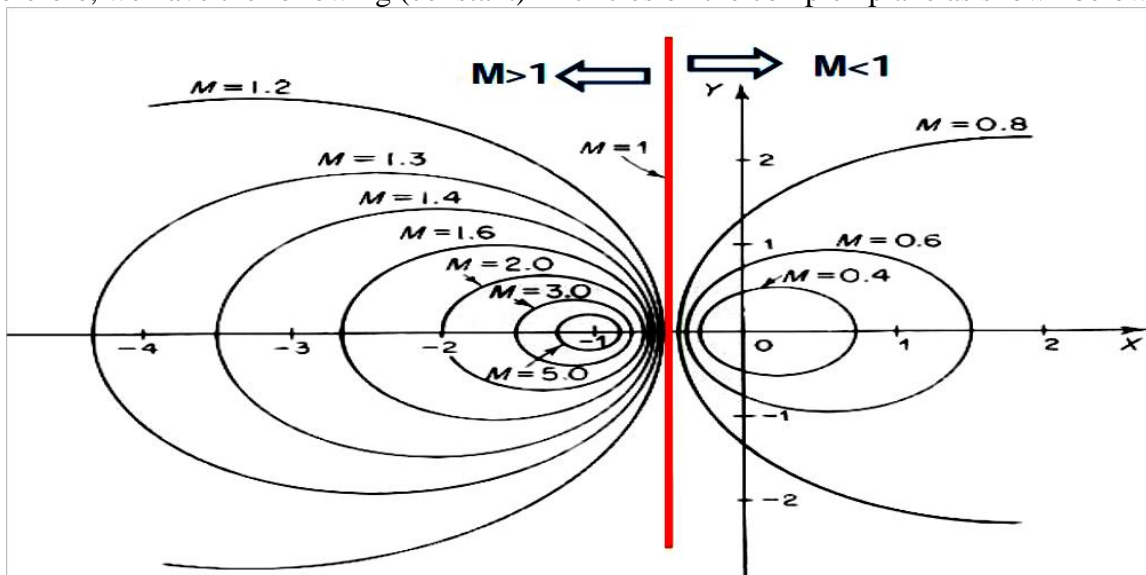

N circles (constant phase of T)

Similarly, it can be shown that the phase of $T(j\omega)$ be

$$\alpha \triangleq \angle T(j\omega) = \tan^{-1} \left[\frac{Y}{X} \right] - \tan^{-1} \left[\frac{Y}{1+X} \right]$$

It can be shown that all (X, Y) pair which corresponds to the same constant phase of T (i.e., constant N) forms a circle on the complex plane as shown below.

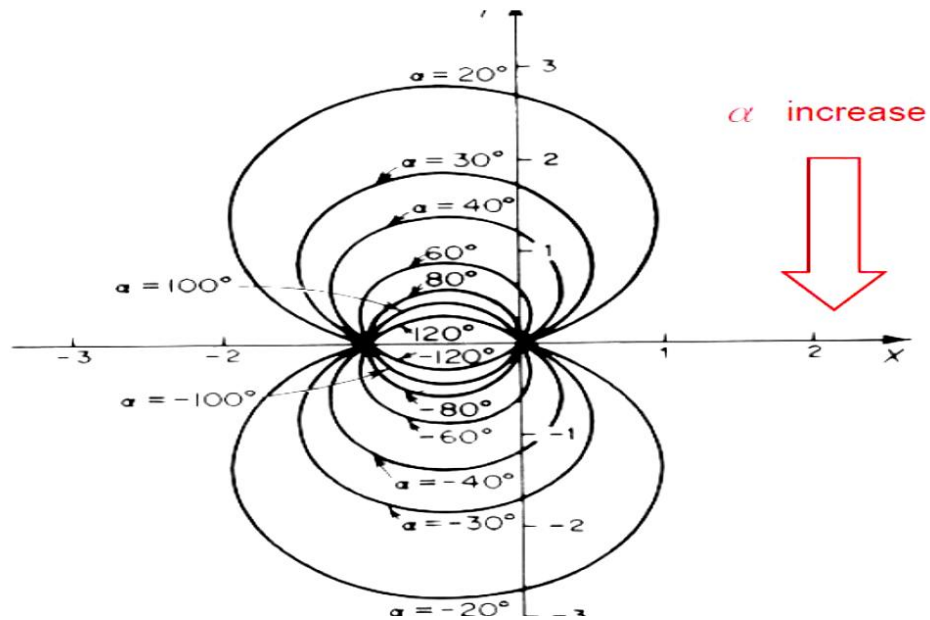

Example

Nyquist plot of $L(j\omega)$, and M-N circles of $T(j\omega)$

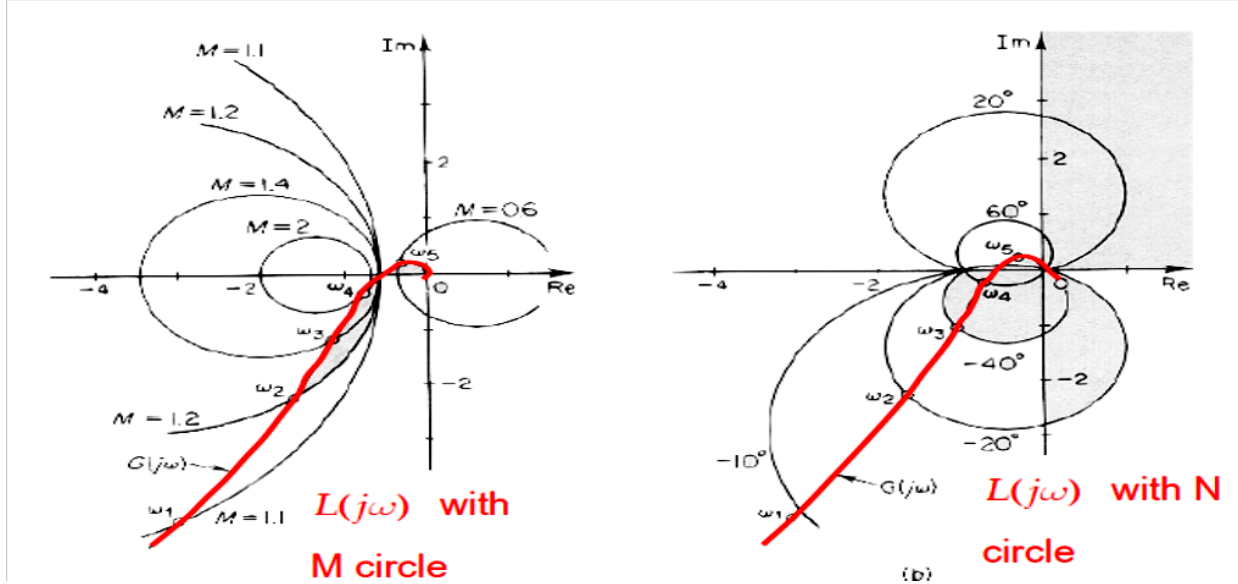

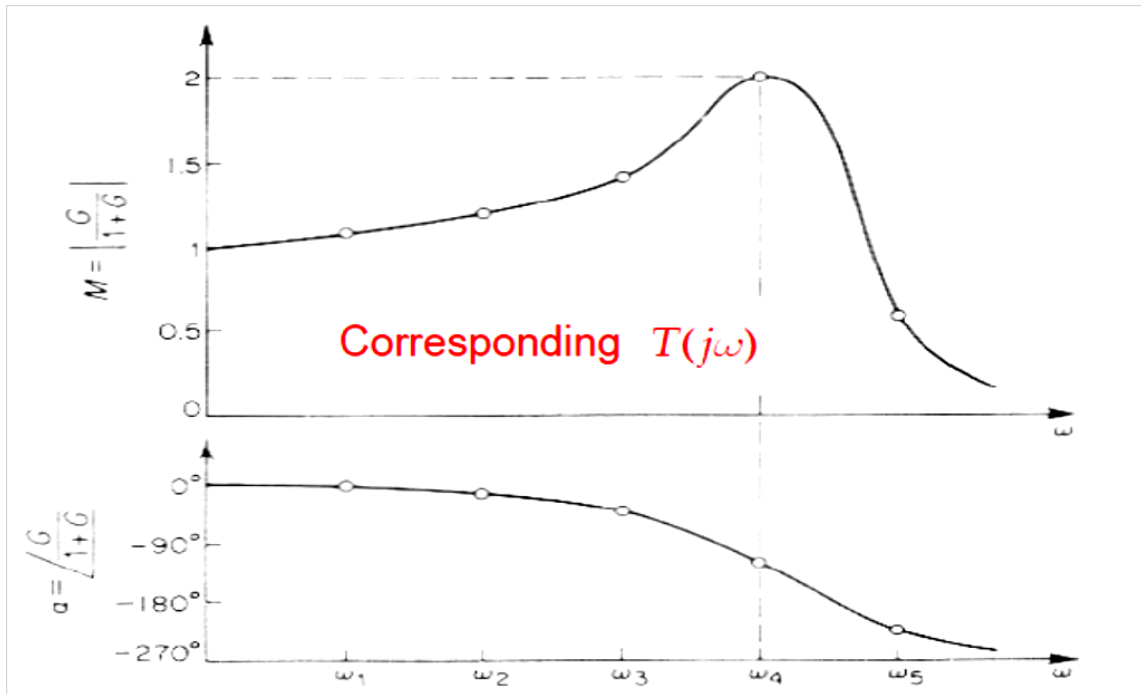

Nichols Chart

The Nyquist plot of $L(j\omega)$ can also be represented by its polar form using dB as magnitude and degree as phase.

$$L(j\omega) = |L|_{dB} e^{j\alpha}$$

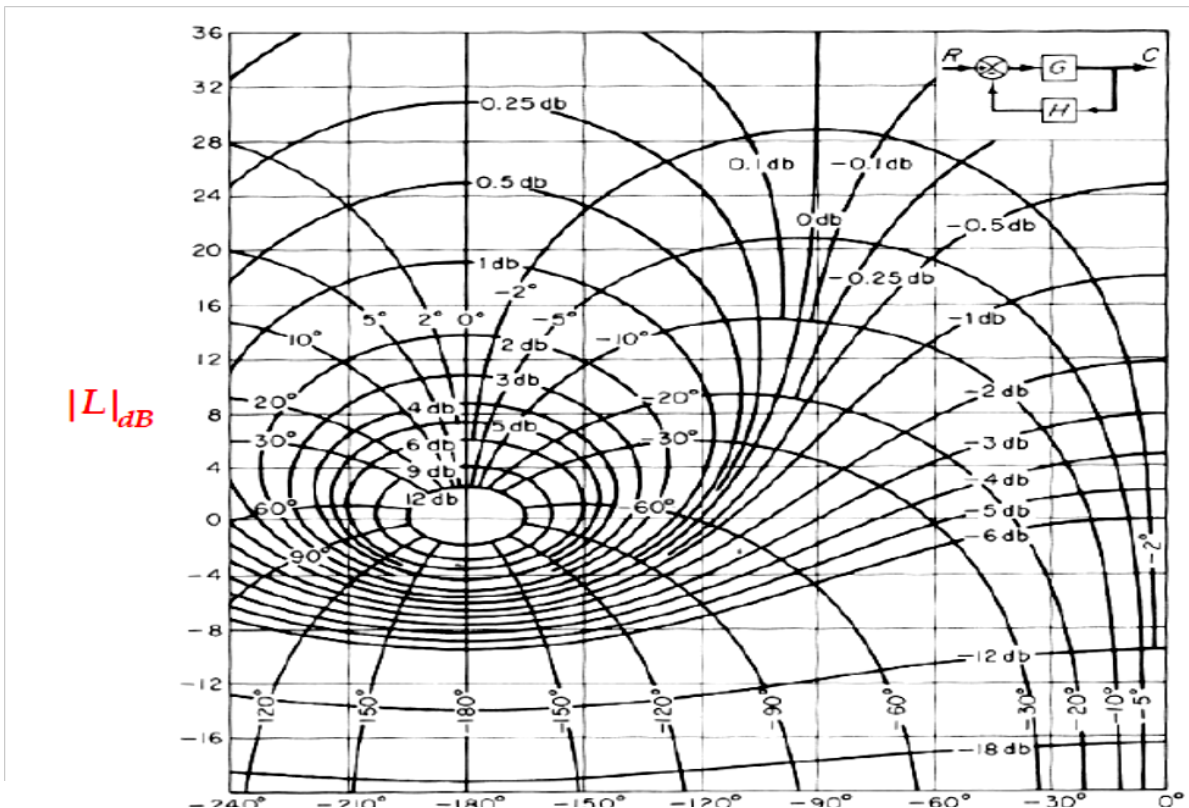

And if $L(j\omega)$ which corresponds to a constant $\alpha(j\omega)$ can be drawn as a locus of M circle on this plane as shown below.

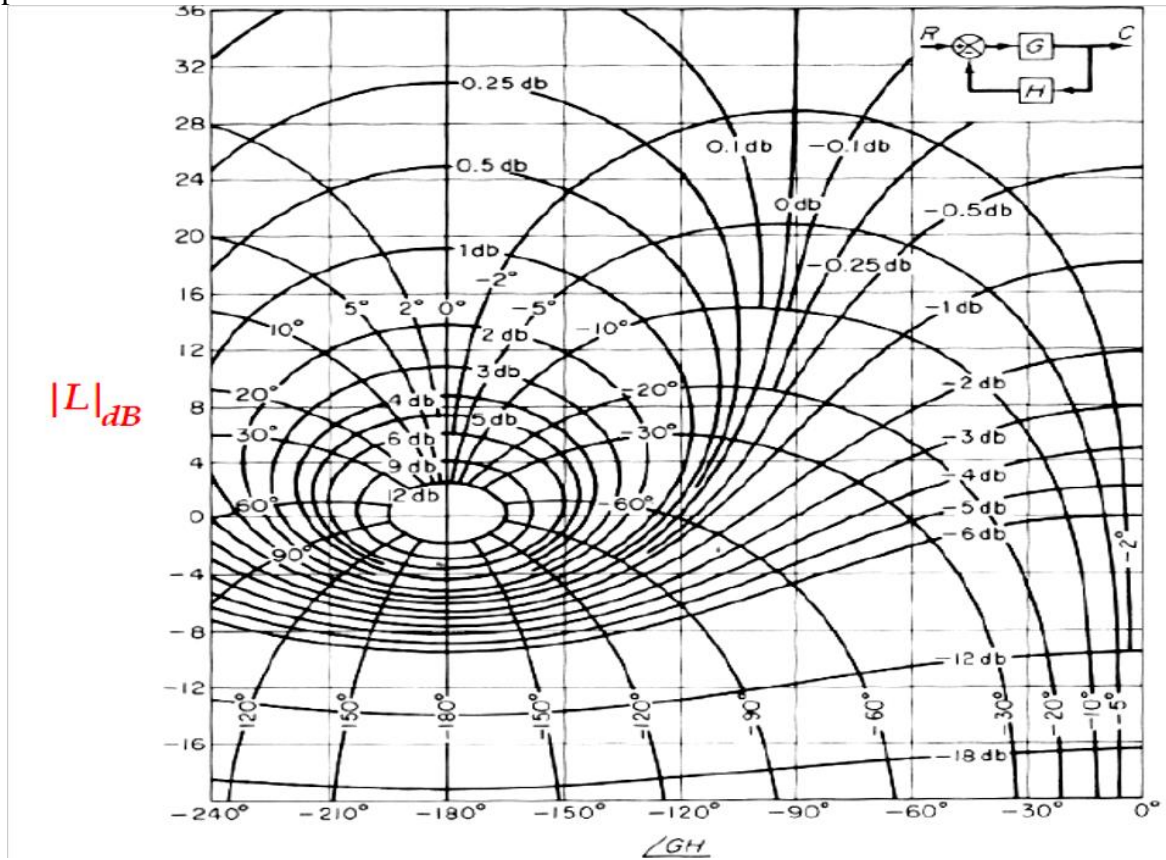

Combining the above two graphs of M circles and N circles, we have the Nicholas chart below.

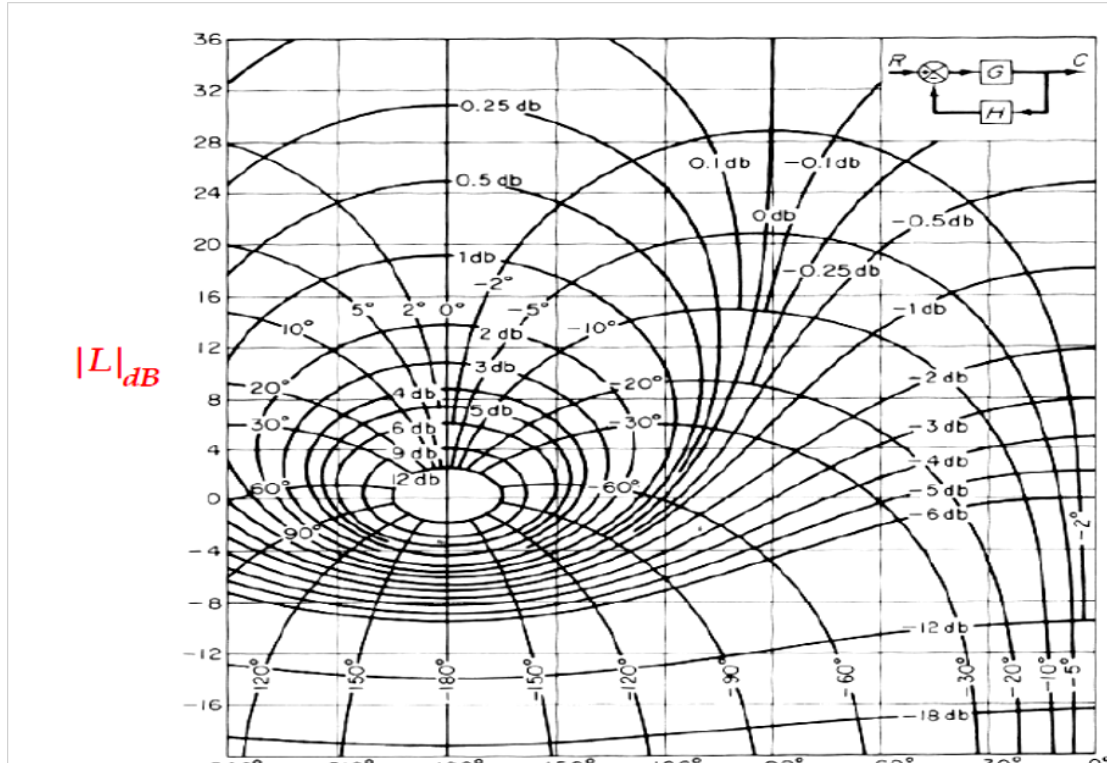

TYPES OF COMPENSATION

- Series Compensation or Cascade Compensation

This is the most commonly used system where the controller is placed in series with the controlled process.

Figure shows the series compensation

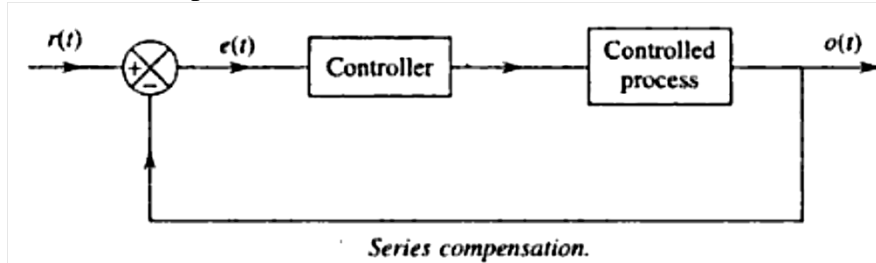

Feedback compensation or Parallel compensation

This is the system where the controller is placed in the sensor feedback path as shown in fig.

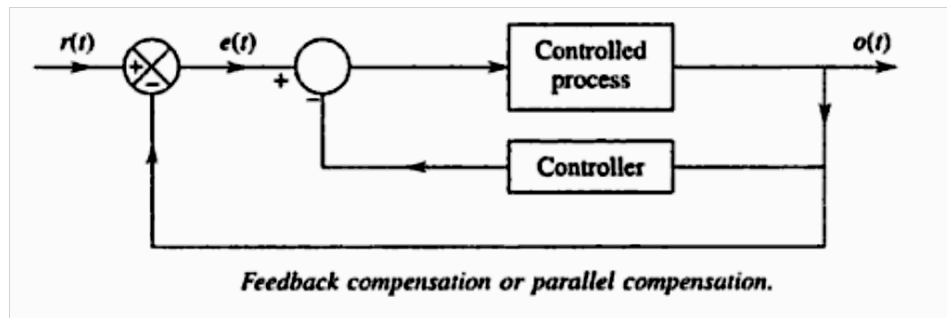

State Feedback Compensation

This is a system which generates the control signal by feeding back the state variables through constant real gains. The scheme is termed state feedback. It is shown in Fig.

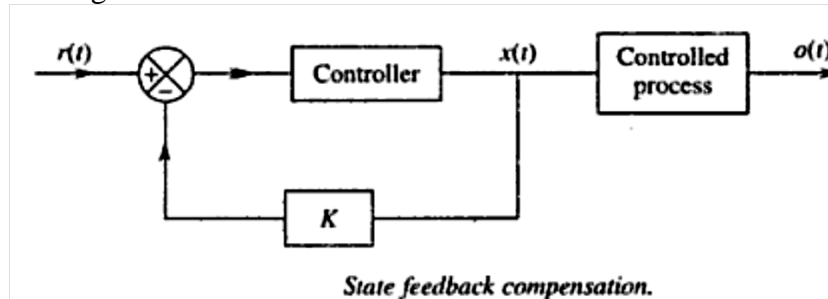

The compensation schemes shown in Figs above have one degree of freedom, since there is only one controller in each system. The demerit with one degree of freedom controllers is that the performance criteria that can be realized are limited.

That is why there are compensation schemes which have two degree freedoms, such as:

- Series-feedback compensation
- Feed forward compensation

Series-Feedback Compensation

Series-feedback compensation is the scheme for which a series controller and a feedback controller are used. Figure 9.6 shows the series-feedback compensation scheme.

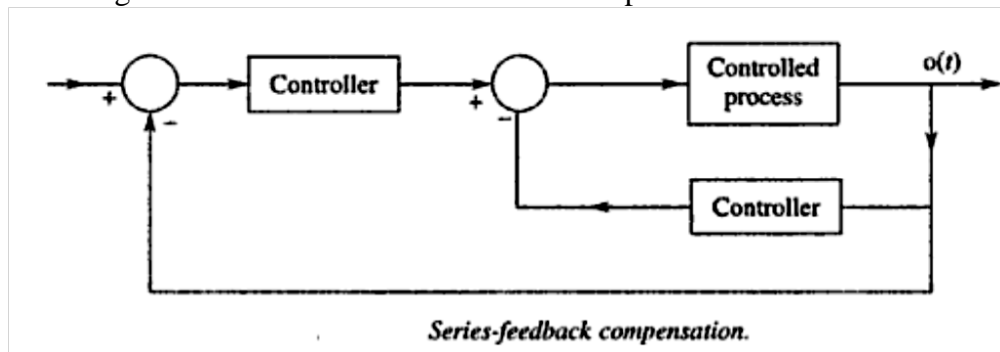

Feed forward Compensation

The feed forward controller is placed in series with the closed-loop system which has a controller in the forward path Orig. 9.71. In Fig. 9.8, Feed forward the is placed in parallel with the controller in the forward path. The commonly used controllers in the above-mentioned compensation schemes are now described in the section below.

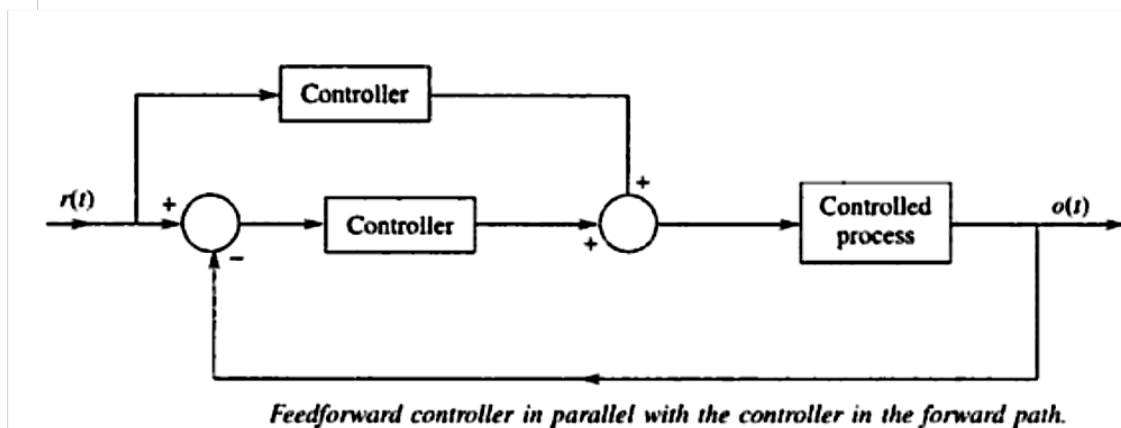
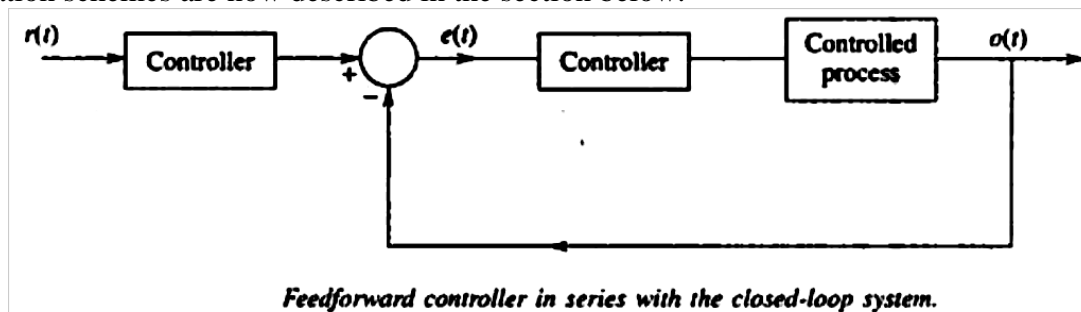

Lead Compensator

It has a zero and a pole with zero closer to the origin. The general form of the transfer function of the lead compensator is

$$G(s) = \frac{s + \frac{1}{\tau}}{s + \frac{1}{\beta\tau}}$$

$$G(j\omega) = \beta \frac{(\tau j\omega + 1)}{\beta\tau j\omega + 1}$$

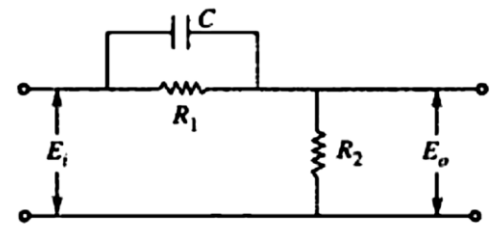

Lead compensator.

$$\begin{aligned} \frac{E_o(s)}{E_i(s)} &= \frac{R_2}{R_1 \times \frac{1}{Cs} + R_2 \left(R_1 + \frac{1}{Cs} \right)} = \frac{R_2 R_1 + \frac{R_2}{Cs}}{R_1 R_2 + \frac{1}{Cs} (R_1 + R_2)} \\ &= \frac{Cs R_1 R_2 + R_2}{Cs R_1 R_2 + R_1 + R_2} \\ &= \frac{R_2 (Cs R_1 + 1)}{(R_1 + R_2) \left(\frac{Cs R_1 R_2}{R_1 + R_2} + 1 \right)} \\ &= \left(\frac{R_2}{R_1 + R_2} \right) \frac{CR_1 s + 1}{\left(\frac{CR_1 R_2 s}{R_1 + R_2} + 1 \right)} \end{aligned}$$

Substituting

$$\tau = CR_1; \quad \beta\tau = \frac{CR_1 R_2}{R_1 + R_2} \quad (\because \tau = CR_1)$$

Transfer function

$$G(s) = \beta \frac{\tau s + 1}{\beta\tau s + 1}$$

Lag Compensator

It has a zero and a pole with the zero situated on the left of the pole on the negative real axis. The general form of the transfer function of the lag compensator is

$$G(s) = \frac{s + \frac{1}{\tau}}{s + \frac{1}{\alpha\tau}} = \frac{\alpha(\tau s + 1)}{\alpha\tau s + 1}$$

where $\alpha > 1$, $\tau > 0$.

Therefore, the frequency response of the above transfer function will be

$$G(j\omega) = \frac{\alpha(\tau j\omega + 1)}{\alpha\tau j\omega + 1}$$

$$E_o(s) = \frac{E_i(s)}{R_1 + R_2 + \frac{1}{Cs}} \left(R_2 + \frac{1}{Cs} \right)$$

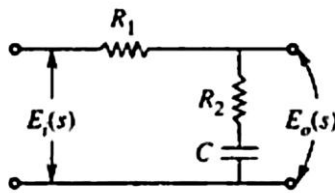

Lag compensator.

$$\begin{aligned} \frac{E_o(s)}{E_i(s)} &= \frac{R_2 + \frac{1}{Cs}}{R_1 + R_2 + \frac{1}{Cs}} \\ &= \frac{R_2Cs + 1}{(R_1 + R_2)Cs + 1} \end{aligned}$$

$$\begin{aligned} &= \frac{R_2C \left(s + \frac{1}{R_2C} \right)}{(R_1 + R_2)C \left(s + \frac{1}{(R_1 + R_2)C} \right)} \\ &= \frac{R_2}{(R_1 + R_2)} \frac{s + \frac{1}{R_2C}}{\left(s + \frac{1}{(R_1 + R_2)C} \right)} = \frac{R_2}{(R_1 + R_2)} \frac{\left(s + \frac{1}{R_2C} \right)}{\left(s + \frac{R_2}{(R_1 + R_2)R_2C} \right)} \end{aligned}$$

Now comparing with

$$G(s) = \frac{s + \frac{1}{\tau}}{s + \frac{1}{\alpha\tau}}$$

$$\frac{1}{\tau} = \frac{1}{R_2 C}; \quad \frac{1}{\alpha \tau} = \frac{R_2}{(R_1 + R_2) R_2 C}$$

$$\frac{1}{\alpha \tau} = \frac{R_2}{(R_1 + R_2) \tau} \quad \left(\because \frac{1}{\tau} = \frac{1}{R_2 C} \right)$$

$$\alpha = \frac{R_1 + R_2}{R_2}$$

Therefore

$$\frac{E_o(s)}{E_i(s)} = \frac{1}{\alpha} \frac{s + \frac{1}{\tau}}{s + \frac{1}{\alpha \tau}}$$

Lag-Lead Compensator

The lag-lead compensator is the combination of a lag compensator and a lead compensator. The lag-section is provided with one real pole and one real zero, the pole being to the right of zero, whereas the lead section has one real pole and one real zero with the zero being to the right of the pole.

The transfer function of the lag-lead compensator will be

$$G(s) = \left(\frac{s + \frac{1}{\tau_1}}{s + \frac{1}{\alpha \tau_1}} \right) \left(\frac{s + \frac{1}{\tau_2}}{s + \frac{1}{\beta \tau_2}} \right)$$

The figure shows lag lead compensator

$$E_o(s) = \frac{E_i(s)}{\frac{R_1 \times \frac{1}{sC_1} + R_2 + \frac{1}{sC_2}}{R_1 + \frac{1}{sC_1}}} \left(R_2 + \frac{1}{sC_2} \right)$$

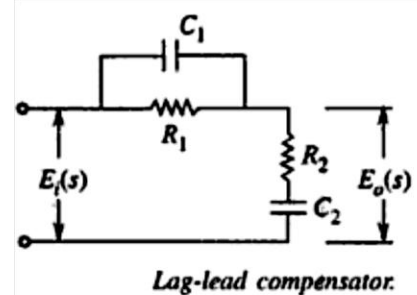

where $\alpha > 1$, $\beta < 1$.

$$\begin{aligned}
 \frac{E_o(s)}{E_i(s)} &= \frac{\left(R_1 + \frac{1}{sC_1}\right)\left(R_2 + \frac{1}{sC_2}\right)}{R_1 \frac{1}{sC_1} + \left(R_2 + \frac{1}{sC_2}\right)\left(R_1 + \frac{1}{sC_1}\right)} \\
 &= \frac{\frac{(sC_1R_1 + 1)(sC_2R_2 + 1)}{sC_1 sC_2}}{\frac{R_1}{sC_1} + \frac{(R_2sC_2 + 1)(R_1sC_1 + 1)}{sC_2}} \\
 &= \frac{\frac{(1 + sC_1R_1)(1 + sC_2R_2)}{s^2C_1C_2}}{\frac{R_1sC_2 + R_2sC_2 + 1 + R_1R_2s^2C_1C_2 + R_1sC_1}{s^2C_1C_2}} \\
 &= \frac{(1 + sC_1R_1)(1 + sC_2R_2)}{s^2R_1R_2C_1C_2 + s(R_1C_1 + R_2C_2) + 1 + R_1sC_2}
 \end{aligned}$$

$$\begin{aligned}
 &= \frac{C_1R_1 C_2R_2 \left(s + \frac{1}{C_1R_1}\right)\left(s + \frac{1}{C_2R_2}\right)}{R_1R_2C_1C_2 \left[s^2 + \left\{ \frac{1}{R_2C_2} + \frac{1}{R_1C_1} + \frac{1}{R_2C_1} \right\} s + \frac{1}{R_1R_2C_1C_2} \right]} \\
 &= \frac{\left(s + \frac{1}{C_1R_1}\right)\left(s + \frac{1}{C_2R_2}\right)}{s^2 + \left(\frac{1}{R_1C_1} + \frac{1}{R_2C_1} + \frac{1}{R_2C_2} \right) s + \frac{1}{R_1R_2C_1C_2}}
 \end{aligned}$$

The above transfer functions are comparing with

$$G(s) = \frac{\left(s + \frac{1}{\tau_1}\right)\left(s + \frac{1}{\tau_2}\right)}{\left(s + \frac{1}{\alpha\tau_1}\right)\left(s + \frac{1}{\beta\tau_2}\right)}$$

Then

$$\frac{1}{\tau_1} = \frac{1}{C_1R_1}, \quad \frac{1}{\tau_2} = \frac{1}{C_2R_2}$$

$$\frac{1}{\alpha\tau_1} + \frac{1}{\beta\tau_2} = \frac{1}{R_1C_1} + \frac{1}{R_2C_1} + \frac{1}{R_2C_2}$$

$$\frac{1}{\alpha\beta\tau_1\tau_2} = \frac{1}{R_1R_2C_1C_2}$$

$$\tau_1 = C_1R_1$$

$$\tau_2 = C_2R_2$$

$$\alpha\beta\tau_1\tau_2 = R_1R_2C_1C_2$$

$$\alpha\beta = 1 \quad \text{or} \quad \beta = \frac{1}{\alpha}$$

Therefore

$$G(s) = \frac{\left(s + \frac{1}{\tau_1}\right)\left(s + \frac{1}{\tau_2}\right)}{\left(s + \frac{1}{\alpha\tau_1}\right)\left(s + \frac{\alpha}{\tau_2}\right)} \quad \text{where } \alpha > 1$$

$$\frac{1}{R_1C_1} + \frac{1}{R_2C_1} + \frac{1}{R_2C_2} = \frac{1}{\alpha\tau_1} + \frac{\alpha}{\tau_2}$$

STATE VARIABLE ANALYSIS

State space representation of Continuous Time systems

The state variables may be totally independent of each other, leading to diagonal or normal form or they could be derived as the derivatives of the output. If there is no direct relationship between various states. We could use a suitable transformation to obtain the representation in diagonal form.

Phase Variable Representation

It is often convenient to consider the output of the system as one of the state variables and remaining state variables as derivatives of this state variable. The state variables thus obtained from one of the system variables and its (n-1) derivatives, are known as n-dimensional phase variables.

In a third-order mechanical system, the output may be displacement x_1 , $x_1 = x_2 = v$ and $x_2 = x_3 = a$ in the case of motion of translation or angular displacement θ , $\dot{\theta} = x_1$, $x_1 = x_2 = w$ and $x_2 = x_3 = \alpha$ if the motion is rotational, Where v, w, a, α respectively, are velocity, angular velocity, angular acceleration, angular acceleration.

Consider a SISO system described by nth-order differential equation.

$$y^{(n)}(t) + a_1 y^{(n-1)}(t) + \dots + a_{n-1} y(t) + a_n y(t) = Ku$$

Where

$$y^{(n)}(t) = d^n y(t)/dt^n,$$

u is, in general, a function of time.

The nth order transfer function of this system is

$$G(s) = \frac{y(s)}{u(s)} = \frac{K}{s^n + a_1 s^{n-1} + \dots + a_{n-1} s + a_n}$$

With the states (each being function of time) be defined as

$$x_1 = y(t), \quad x_2 = \dot{y}(t), \quad x_3 = \ddot{y}(t), \quad \dots, \quad x_n = y^{(n-1)}(t),$$

Equation becomes

$$\begin{aligned} \dot{x}_n + a_1 x_n + a_2 x_{n-1} + \dots + a_{n-1} x_2 + a_n x_1 &= Ku(t) \\ \dot{x}_n &= -a_1 x_n - a_2 x_{n-1} - \dots - a_{n-1} x_2 - a_n x_1 + Ku \end{aligned}$$

Using above Eqs state equations in phase variable form can be obtained as

$$\dot{\mathbf{x}} = \begin{bmatrix} \dot{x}_1 \\ \dot{x}_2 \\ \vdots \\ \dot{x}_n \end{bmatrix} = \begin{bmatrix} 0 & 1 & 0 & \dots & 0 & 0 \\ 0 & 0 & 1 & \dots & 0 & 0 \\ \dots & \dots & \dots & \dots & \dots & \dots \\ 0 & 0 & 0 & \dots & 0 & 1 \\ -a_n & -a_{n-1} & -a_{n-2} & \dots & a_2 & -a_1 \end{bmatrix} \begin{bmatrix} x_1 \\ x_2 \\ \vdots \\ x_n \end{bmatrix} + \begin{bmatrix} 0 \\ 0 \\ \vdots \\ 0 \\ K \end{bmatrix} u$$

Where

$$y = [1 \ 0 \ 0 \ \dots \ 0]x$$

$$x = [x_1 \ x_2 \ \dots \ x_n]^T$$

Physical Variable Representation

In this representation the state variables are real physical variables, which can be measured and used for manipulation or for control purposes. The approach generally adopted is to break the block diagram of the transfer function into subsystems in such a way that the physical variables can be identified. The governing equations for the subsystems can be used to identify the physical variables. To illustrate the approach consider the block diagram of Fig.

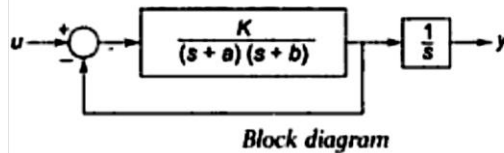

One may represent the transfer function of this system as

$$T(s) = \frac{y(s)}{u(s)} = \frac{K}{K + (s+a)(s+b)} \cdot \frac{1}{s} = \frac{G(s)}{1 + G(s)H(s)} \cdot \frac{1}{s} = \frac{K / (s+a)(s+b)}{1 + K / (s+a)(s+b)} \cdot \frac{1}{s}$$

Taking $H(s) = 1$, the block diagram of can be redrawn as in Fig. physical variables can be speculated as $x_1 = y$, output, $x_2 = w = \dot{\theta}$ the angular velocity $x_3 = I_a$ the armature current in a position-control system.

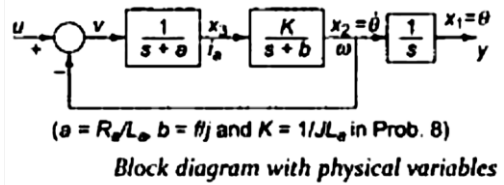

Where

$$x_1 = y, s x_1 = x_2, v = (s+a) x_3$$

The state space representation can be obtained by

$$\dot{x}_1 = x_2, \dot{x}_2 = -b x_2 + K x_3, \dot{x}_3 = -a x_3 - x_2 + u, y = x_1$$

$$\begin{bmatrix} \dot{x}_1 \\ \dot{x}_2 \\ \dot{x}_3 \end{bmatrix} = \begin{bmatrix} 0 & 1 & 0 \\ 0 & -b & K \\ 0 & -1 & -a \end{bmatrix} \begin{bmatrix} x_1 \\ x_2 \\ x_3 \end{bmatrix} + \begin{bmatrix} 0 \\ 0 \\ 1 \end{bmatrix} u$$

And

$$y(t) = [1 \ 0 \ 0] \begin{bmatrix} x_1 \\ x_2 \\ x_3 \end{bmatrix}$$

Solution of State equations

Consider the state equation n of linear time invariant system as,

$$\dot{X}(t) = AX(t) + BU(t)$$

The matrices A and B are constant matrices. This state equation can be of two types,

1. Homogeneous and
2. Non homogeneous

Homogeneous Equation

If A is a constant matrix and input control forces are zero then the equation takes the form,

$$\dot{X}(t) = A X(t)$$

Such an equation is called homogeneous equation. The obvious equation is if input is zero, In such systems, the driving force is provided by the initial conditions of the system to produce the output. For example, consider a series RC circuit in which capacitor is initially charged to V volts. The current is the output. Now there is no input control force i.e. external voltage applied to the system. But the initial voltage on the capacitor drives the current through the system and capacitor starts discharging through the resistance R. Such a system which works on the initial conditions without any input applied to it is called homogeneous system.

Non homogeneous Equation

If A is a constant matrix and matrix U(t) is non-zero vector i.e. the input control forces are applied to the system then the equation takes normal form as,

$$\dot{X}(t) = A X(t) + B U(t)$$

Such an equation is called non homogeneous equation. Most of the practical systems require inputs to drive them. Such systems are non homogeneous linear systems. The solution of the state equation is obtained by considering basic method of finding the solution of homogeneous equation.

Controllability and Observability

More specially, for system of Eq.(1), there exists a similar transformation that will diagonalize the system. In other words, There is a transformation matrix Q such that

$$\dot{X} = AX + Bu \quad ; \quad y = CX + Du \quad ; \quad X(0)=X_0 \quad (1)$$

$$\hat{X} = QX \quad \text{or} \quad X=Q^{-1}\hat{X} \quad (2)$$

$$\dot{\hat{X}} = \Lambda\hat{X} + \hat{B}u \quad y = \hat{C}\hat{X} + \hat{D}u \quad (3)$$

$$\text{Where } \Lambda = \begin{bmatrix} \lambda_1 & 0 & \dots & 0 \\ 0 & \lambda_2 & \dots & 0 \\ & & \ddots & \\ 0 & \dots & & \lambda_n \end{bmatrix} \quad (4)$$

Notice that by doing the diagonalizing transformation, the resulting transfer function between u(s) and y(s) will not be altered.

Looking at Eq.(3), if $\hat{b}_k = 0$, then $x_k(t)$ is uncontrollable by the input u(t), since, $x_k(t)$ is characterized by the mode $e^{-\lambda_k t}$ by the equation.

$$x_k(t) = e^{\lambda_k t} x_k(0_-)$$

The lack of controllability of the state $x_k(t)$ is reflected by a zero kth row of B. i.e. $b_k = 0$. Which would cause a complete zero row in the following matrix (known as the controllability matrix), i.e.:

$$C(A,b) = \begin{bmatrix} \hat{B} & \hat{A}\hat{B} & \hat{A}^2\hat{B} & \hat{A}^3\hat{B} & \dots & \hat{A}^{n-1}\hat{B} \end{bmatrix} \dots = \begin{bmatrix} \hat{b}_1 & \lambda_1 \hat{b}_1 & \lambda_1^2 \hat{b}_1 & \dots & \lambda_1^{n-1} \hat{b}_1 \\ \hat{b}_2 & \lambda_2 \hat{b}_2 & \lambda_2^2 \hat{b}_2 & \dots & \lambda_2^{n-1} \hat{b}_2 \\ \dots & \dots & \dots & \dots & \dots \\ \hat{b}_k & \lambda_k \hat{b}_k & \lambda_k^2 \hat{b}_k & \dots & \lambda_k^{n-1} \hat{b}_k \\ \dots & \dots & \dots & \dots & \dots \\ \hat{b}_n & \lambda_n \hat{b}_n & \dots & \dots & \lambda_n^{n-1} \hat{b}_n \end{bmatrix}$$

A $C(A,b)$ matrix with all non-zero row has a rank of n .

In fact, $B = Q^{-1}\hat{B}$ or $\hat{B} = QB$. Thus, a non-singular $C(A,b)$ matrix implies a non-singular matrix of $C(A,b)$ of the following:

$$C(A,b) = \begin{bmatrix} B & AB & A^2B & \dots & A^{n-1}B \end{bmatrix}$$

Transfer function from State Variable Representation

A simple example of system has an input and output as shown in Figure 1. This class of system has general form of model given in Eq.(1).

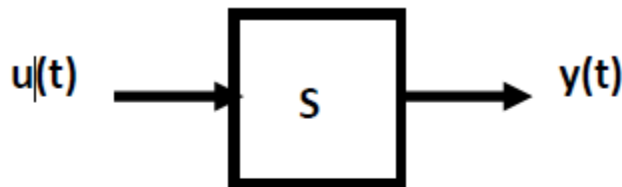

$$\frac{d^n y}{dt^n} + a_{n-1} \frac{d^{n-1} y}{dt^{n-1}} + \dots + a_0 y(t) = b_{m-1} \frac{d^{m-1} u}{dt^{m-1}} + \dots + b_0 u(t)$$

Models of this form have the property of the following:

$$u(t) = \alpha_1 u_1(t) + \alpha_2 u_2(t) \Rightarrow y(t) = \alpha_1 y_1(t) + \alpha_2 y_2(t) \quad (2)$$

where, (y_1, u_1) and (y_2, u_2) each satisfies Eq.(1).

Model of the form of Eq.(1) is known as linear time invariant (abbr. **LTI**) system. Assume the system is at rest prior to the time $t_0=0$, and, the input $u(t)$ ($0 \leq t < \infty$) produces the output $y(t)$ ($0 \leq t < \infty$), the model of Eq.(1) can be represented by a transfer function in term of Laplace transform variables, i.e.:

$$y(s) = \frac{b_m s^m + b_{m-1} s^{m-1} + \dots + b_0}{a_n s^n + a_{n-1} s^{n-1} + \dots + a_0} u(s) \quad (3)$$

Then applying the same input shifted by any amount τ of time produces the same output shifted by the same amount τ of time. The representation of this fact is given by the following transfer function:

$$y(s) = \left(\frac{b_m s^m + b_{m-1} s^{m-1} + \dots + b_0}{a_n s^n + a_{n-1} s^{n-1} + \dots + a_0} \right) e^{-\tau s} u(s) \quad (4)$$

Models of Eq.(1) having all $b_i = 0$ ($i > 0$), a state space description arose out of a reduction to a system of first order differential equations. This technique is quite general. First, Eq.(1) is written as:

$$y^{(n)} = f(t, u(t), y, \dot{y}, \ddot{y}, \dots, y^{(n-1)}); \quad (5)$$

with initial conditions: $y(0) = y_0, \dot{y}(0) = y_1(0), \dots, y^{(n-1)}(0) = y_{n-1}(0)$

Consider the vector $x \in R^n$ with $x_1 = y, x_2 = \dot{y}, x_3 = \ddot{y}, \dots, x_n = y^{(n-1)}$, Eq.(5) becomes

$$\frac{d}{dt} X = \begin{bmatrix} x_2 \\ x_3 \\ \vdots \\ x_n \\ f(t, u(t), y, \dot{y}, \ddot{y}, \dots, y^{(n-1)}) \end{bmatrix} \quad (6)$$

In case of linear system, Eq.(6) becomes:

$$\frac{d}{dt} X = \begin{bmatrix} 0 & 1 & 0 & \dots & \dots & 0 \\ 0 & 0 & 1 & 0 & \dots & 0 \\ & & & \ddots & & \\ 0 & 0 & \dots & \ddots & & 1 \\ -a_0 & -a_1 & \dots & -a_{n-1} & & \end{bmatrix} X + \begin{bmatrix} 0 \\ 0 \\ \vdots \\ 0 \\ 1 \end{bmatrix} u(t); \quad y(t) = [1 \ 0 \ 0 \ \dots \ 0] X \quad (7)$$

It can be shown that the general form of Eq.(1) can be written as

$$\frac{d}{dt} X = \begin{bmatrix} 0 & 1 & 0 & \dots & \dots & 0 \\ 0 & 0 & 1 & 0 & \dots & 0 \\ & & & \ddots & & \\ 0 & 0 & \dots & \ddots & & 1 \\ -a_0 & -a_1 & \dots & -a_{n-1} & & \end{bmatrix} X + \begin{bmatrix} 0 \\ 0 \\ \vdots \\ 0 \\ 1 \end{bmatrix} u(t); \quad y(t) = [b_0 \ b_1 \ \dots \ b_m \ 0 \ \dots \ 0] X \quad (8)$$

and, will be represented in an abbreviation form:

$$\dot{X} = AX + Bu; \quad y = CX + Du; \quad D=0 \quad (9)$$

Eq.(9) is known as the controller canonical form of the system.

State space representation for discrete time systems

The dynamics of a linear time (shift) invariant discrete-time system may be expressed in terms state (plant) equation and output (observation or measurement) equation as follows

$$\begin{aligned} \mathbf{x}(k+1) &= A\mathbf{x}(k) + B\mathbf{u}(k), \\ \mathbf{y}(k) &= C\mathbf{x}(k) + D\mathbf{u}(k) \end{aligned}$$

Where $x(k)$ an n dimensional state vector at time $t = kT$, an r -dimensional control (input) vector $y(k)$, an m -dimensional output vector, respectively, are represented as

$$\mathbf{x}(k) = [x_1(k), x_2(k), \dots, x_n(k)]^T, \quad \mathbf{u}(k) = [u_1(k), u_2(k), \dots, u_r(k)]^T, \quad \mathbf{y}(k) = [y_1(k), y_2(k), \dots, y_m(k)]^T.$$

The parameters (elements) of A , an $n \times n$ (plant parameter) matrix. B an $n \times r$ control (input) matrix, and C An $m \times r$ output parameter, D an $m \times r$ parametric matrix are constants for the LTI system. Similar to above equation state variable representation of SISO (single output and single input) discrete-time system (with direct coupling of output with input) can be written as

$$\begin{aligned} \mathbf{x}(k+1) &= A\mathbf{x}(k) + \mathbf{b}u(k) \\ y(k) &= \mathbf{c}^T \mathbf{x}(k) + du(k) \end{aligned}$$

Where the input u , output y and d . are scalars, and \mathbf{b} and \mathbf{c} are n -dimensional vectors. The concepts of controllability and observability for discrete time system are similar to the continuous-time system. A discrete time system is said to be controllable if there exists a finite integer n and input $u(k)$; $k [0, n-1]$ that will transfer any state $x(0)$ to the state x^n at $k = n$.

Sampled Data System

When the signal or information at any or some points in a system is in the form of discrete pulses. Then the system is called discrete data system. In control engineering the discrete data system is popularly known as sampled data systems.

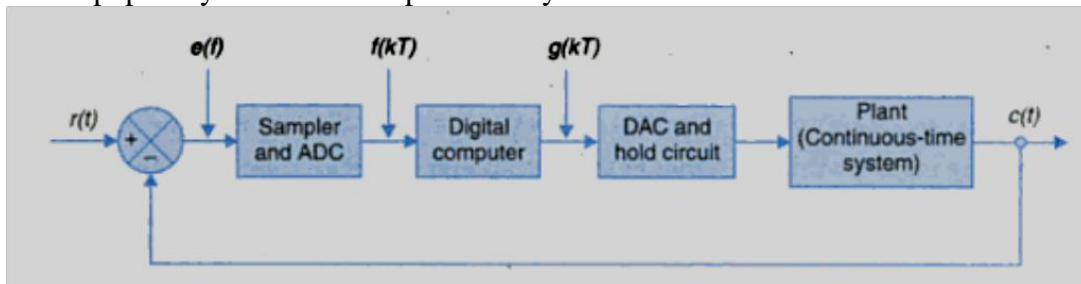

Sampling Theorem

A band limited continuous time signal with highest frequency f_m hertz can be uniquely recovered from its samples provided that the sampling rate F_s is greater than or equal to $2f_m$ samples per seconds.

Sample & Hold

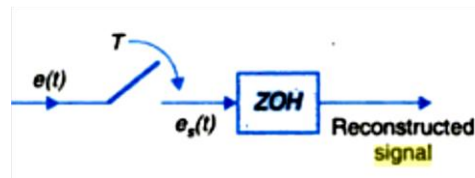

The Signal given to the digital controller is a sampled data signal and in turn the controller gives the controller output in digital form. But the system to be controlled needs an analog control signal as input. Therefore the digital output of controllers must be converted into analog form.

This can be achieved by means of various types of hold circuits. The simplest hold circuits are the zero order hold (ZOH). In ZOH, the reconstructed analog signal acquires the same values as the last received sample for the entire sampling period.

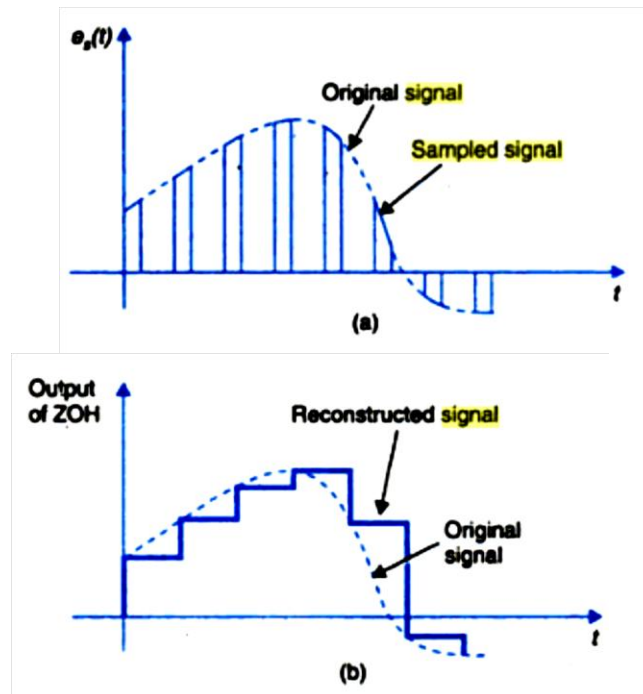

The high frequency noises present in the reconstructed signal are automatically filtered out by the control system component which behaves like low pass filters. In a first order hold the last two signals for the current sampling period. Similarly higher order hold circuit can be devised. First or higher order hold circuits offer no particular advantage over the zero order hold.